

PACMotion™ VFD Input/Output Chokes (IP20 and IP66 Versions)

INSTALLATION GUIDE



Contents

Section 1:	Important Safety Information	1
Section 2:	Input Line Chokes	2
2.1	Using Input Chokes.....	2
2.2	Dimensions – IP20 Single Phase Versions.....	2
2.3	Mounting Dimensions – IP66 Versions.....	4
2.4	Installation Schematic Diagram	4
Section 3:	Output Line Chokes.....	5
3.1	Using Output Chokes.....	5
3.2	Dimensions – Open Type.....	5
3.3	Mounting Dimensions – Enclosed Versions.....	6
3.4	Installation Schematic Diagram	6
	General Contact Information	7
	Technical Support.....	7

Warnings and Caution Notes as Used in this Publication

WARNING

Warning notices are used in this publication to emphasize that hazardous voltages, currents, temperatures, or other conditions that could cause personal injury exist in this equipment or may be associated with its use.

In situations where inattention could cause either personal injury or damage to equipment, a Warning notice is used.

CAUTION

Caution notices are used where equipment might be damaged if care is not taken.

Note: Notes merely call attention to information that is especially significant to understanding and operating the equipment.

These instructions do not purport to cover all details or variations in equipment, nor to provide for every possible contingency to be met during installation, operation, and maintenance. The information is supplied for informational purposes only, and Emerson makes no warranty as to the accuracy of the information included herein. Changes, modifications, and/or improvements to equipment and specifications are made periodically and these changes may or may not be reflected herein. It is understood that Emerson may make changes, modifications, or improvements to the equipment referenced herein or to the document itself at any time. This document is intended for trained personnel familiar with the Emerson products referenced herein.

Emerson may have patents or pending patent applications covering subject matter in this document. The furnishing of this document does not provide any license whatsoever to any of these patents.

Emerson provides the following document and the information included therein as-is and without warranty of any kind, expressed or implied, including but not limited to any implied statutory warranty of merchantability or fitness for particular purpose.

Section 1: Important Safety Information

This option is specifically designed to be used with the VFD variable speed drive product range and is intended for professional incorporation into complete equipment or systems. If installed incorrectly, it may present a safety hazard. The VFD uses high voltages and currents, carries a high level of stored electrical energy, and is used to control mechanical plants, which may cause injury. Close attention to system design and electrical installation is required to avoid hazards during normal operation or in the event of an equipment malfunction. VFDs and its options should be installed only by qualified electrical personnel and in accordance with local and national regulations and codes of practice.

WARNING

Electric shock hazard!

Disconnect and **ISOLATE** the VFD before attempting any work on it. High voltages are present at the terminals and within the drive for up to **10 minutes** after the disconnection of the electrical supply.

Wait until 10 minutes have elapsed after turning off the power supply before disconnecting the plug that supplies power to the drive.

It is the responsibility of the installer to ensure that the equipment or system into which the product is incorporated complies with the EMC legislation of the country of use. Within the European Union, equipment into which this product is incorporated must comply with 2004/108/EC, Electromagnetic Compatibility.

Within the European Union, all machinery in which this product is used must comply with the Directive 98/37/EC, Safety of Machinery. In particular, the equipment should comply with EN60204-1.

The manufacturer accepts no liability for any consequences resulting from inappropriate, negligent, or incorrect installation.

The contents of this installation guide are believed to be correct at the time of printing. In the interests of a commitment to a policy of continuous improvement, the manufacturer reserves the right to change the specification of the product or its performance or the contents of this installation guide without notice.

Section 2: Input Line Chokes

2.1 Using Input Chokes

Input chokes help to protect the VFD from spikes on the incoming power supply, as well as reducing input harmonic currents. It is recommended that an input choke is used under the following circumstances:

- On all 600 Volt Size 2 and 3 VFDs
- On all applications where the incoming power supply uses a sliding busbar or brush-gear-type arrangement (e.g. commonly used on overhead cranes)
- On all installations where the supply impedance is low or the fault current is very high
- On all installations where the incoming power supply is prone to spikes, dips notches, or other disturbances

Typically, the input choke will provide a significant reduction in harmonic distortion on the incoming power supply, and will reduce the overall current into the drive cover and back pages.

2.2 Dimensions – IP20 Single Phase Versions

Part Number	VFD Size	Connection (mm ²)	L (mm)	H (mm)	B (mm)	N1 (mm)	N2 (mm)	ØD (mm)	Rated Volts	Rated Amps	Inductance (mH)	Weight (kg)
IC866-ICH-016-201-20	1	4	78	80	78	56	49	4.8	230 Max	16	1.8	1.1
IC866-ICH-025-201-20	2	10	85	158	76	100	55	5		25	1.1	1.8

Figure 1: Front Profile

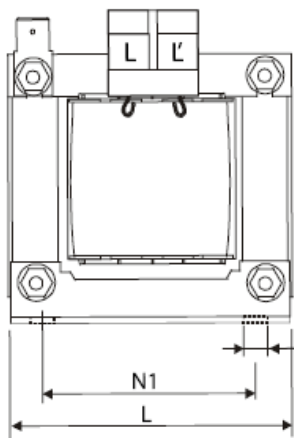
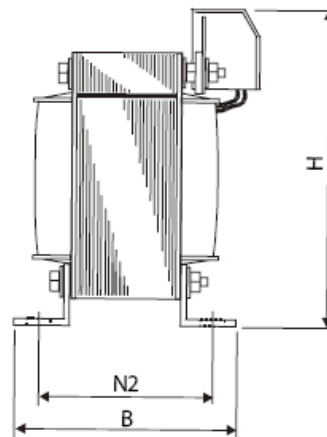

Figure 2: Left Profile



Part Number	VFD Size	Connection (mm ²)	L (mm)	H (mm)	B (mm)	N1 (mm)	N2 (mm)	ØD (mm)	Rated Volts	Rated Amps	Inductance (mH)	Weight (kg)
IC866-ICH-006-603-20	1	2.5	95	107	56	56	43	4.8 x 9	500 Max	6	4.8	1.3
IC866-ICH-010-603-20	2	2.5	125	127	71	100	55	5 x 8		10	2.9	2.5
IC866-ICH-036-603-20	3	10	190	205	82	170	58	8 x 12		36	0.81	7.2
IC866-ICH-050-603-20	4	16	190	220	102	170	78	8 x 12		50	0.58	8.7
IC866-ICH-090-603-20	5	35	240	280	107	185	85	10 x 18		90	0.32	16

Figure 3: IC866-ICH-006-603-20, IC866-ICH-010-603-20

Figure 4: IC866-ICH-036-603-20, IC866-ICH-050-603-20, IC866-ICH-090-603-20

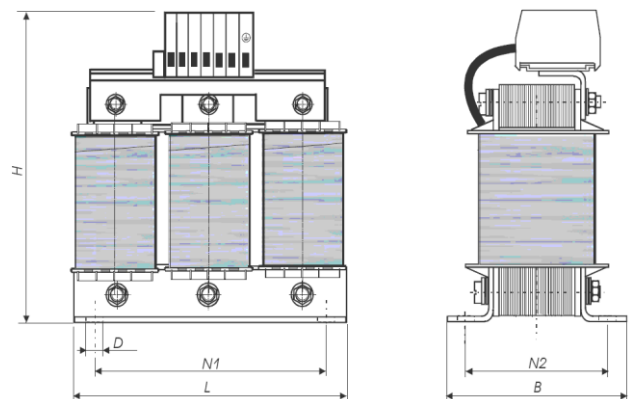
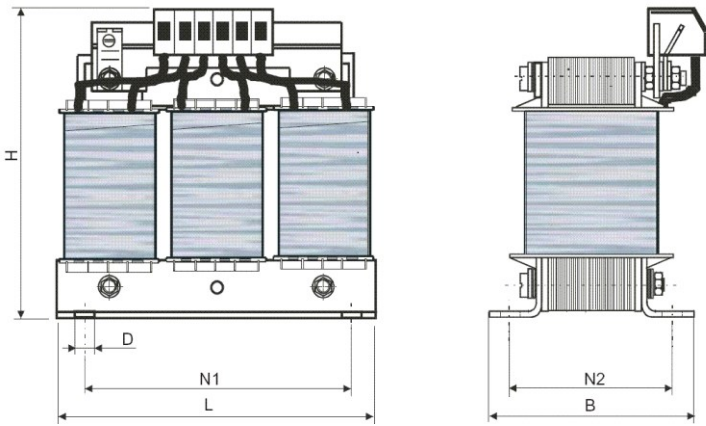

Part Number	VFD Size	Connection D2 (mm)	L (mm)	H (mm)	B (mm)	N1 (mm)	N2 (mm)	ØD (mm)	Rated Volts	Rated Amps	Inductance (µH)	Weight (kg)
IC866-ICH-200-603-00	6	9	310	260	180	224	117	10 x 18	500	200	73.5	35
IC866-ICH-300-603-00	7	9	370	310	180	248	139	10 x 18		300	49.0	48

Figure 5: IC866-ICH-200-603-00

Figure 6: IC866-ICH-300-603-00

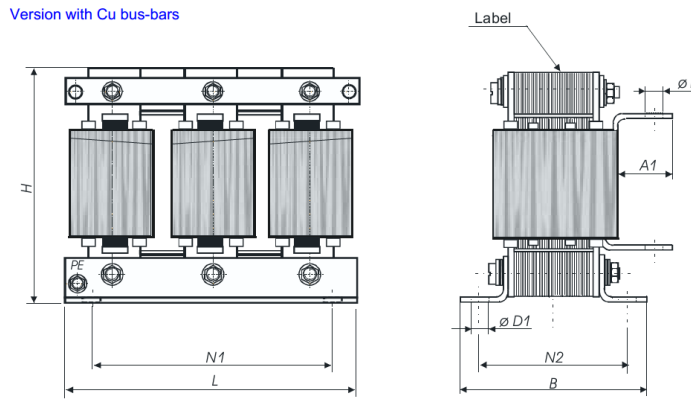
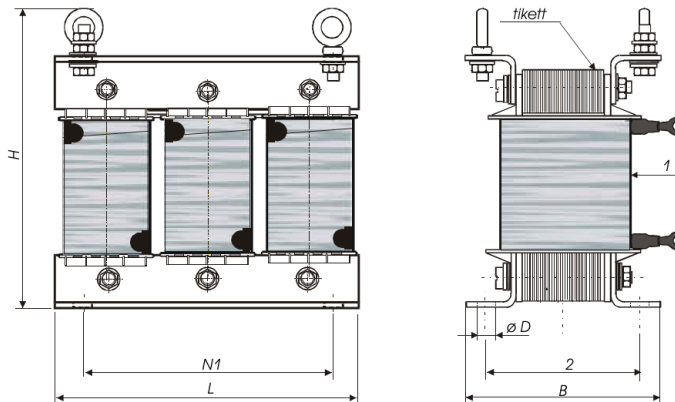

2.3 Mounting Dimensions – IP66 Versions

Part Number	VFD Size	Connection (mm ²)	L (mm)	H (mm)	B (mm)	N1 (mm)	N2 (mm)	ØD (mm)	L1 (mm)	H1 (mm)	B1 (mm)	Rated Volts	Rated Amps	Inductance (mH)	Weight (kg)
IC866-ICH-016-201-60	1	4	82	70	70	70	58	6	151	60	85	230 Max	16	1.83	1.0
IC866-ICH-025-201-60	2	10	90	75	84	84	72	6	151	60	85		25	1.17	1.3
IC866-ICH-006-603-60	1	2.5	115	88	74	80	60	5.5 x 7	151	60	85	600 Max	6	4.8	1.6
IC866-ICH-010-603-60	2	2.5	175	137	99	130	79	5.5 x 12	151	60	85		10	3.86	3.5
IC866-ICH-018-603-60	3	10	175	137	114	130	94	5.5 x 12	151	60	85		18	2.04	7

Figure 7: Dimensions of Enclosed Versions

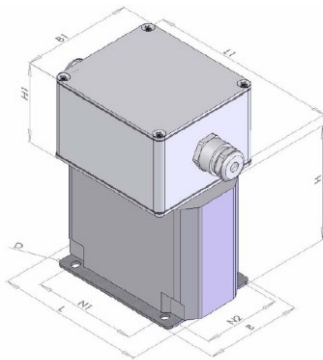

2.4 Installation Schematic Diagram

Figure 8: Single-Phase Supply Installation

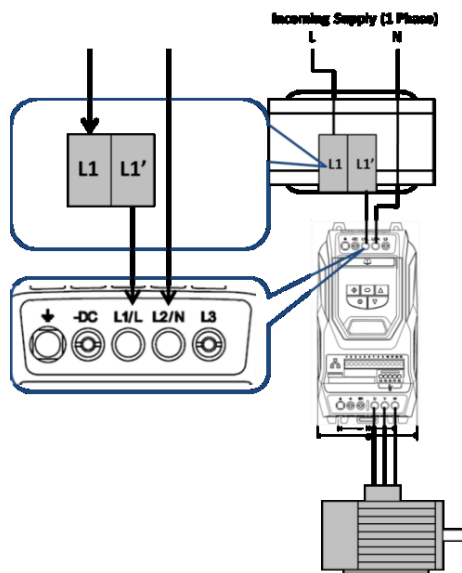
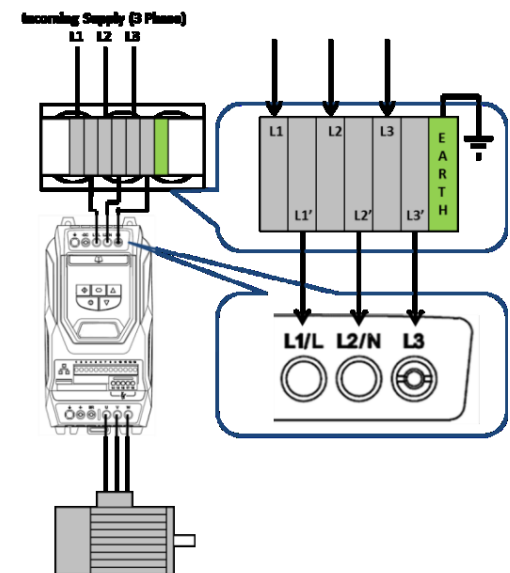

Figure 9: Three-Phase Supply Installation



Section 3: Output Line Chokes

3.1 Using Output Chokes

AC Inverters use a fast switching pulse width modulation (PWM) technique to create a variable frequency AC Output to the connected motor. The fast switching of the output of the drive when connected with long motor cables results in a reflected voltage at the motor which can be up to three times the AC supply voltage, with a very fast rise time. Output chokes help to reduce this peak voltage, and increase the rise time, to reduce the stress applied to the motor insulation and prevent damage. Output chokes are recommended whenever any of the following conditions are met:

- The connected motor is not known to be suitable for use with a PWM output Inverter (as confirmed with the motor manufacturer)
- The motor cable length exceeds the maximum permissible motor cable length stated for the product in the relevant user manual
 - Specified cable lengths apply to standard type copper shielded cable only
 - For unshielded cables, the maximum length may increase by 50%
 - Using a choke allows the maximum cable length to increase by 100%
- High capacitance motor cable is used, e.g. typically fire-resistant cables

3.2 Dimensions – Open Type

Part Number	VFD Size	Connection	L (mm)	H (mm)	B (mm)	N1 (mm)	N2 (mm)	ØD (mm)	Rated Volts	Rated Amps	Inductance (mH)	Weight (kg)
IC866-OCH-008-603-20	1	2.5 mm ²	95	107	61	56	43	4	500 Max	8	2.0	1.5
IC866-OCH-012-603-20	2	4 mm ²	125	158	76	100	55	5		12	1.7	2.8
IC866-OCH-030-603-20	3	10 mm ²	155	185	66	130	57	8		30	0.5	4.2
IC866-OCH-075-603-20	4 & 5	35 mm ²	190	223	92	170	68	8		75	0.22	8.6
IC866-OCH-180-603-00	5 & 6	11 mm	340	292	138	248	110	10 x 18	400 Max	180	0.09	32
IC866-OCH-300-603-00	7	9 mm	380	310	180	248	139	10 x 18		300	0.053	48

Figure 10: IC866-OCH-008-603-20 through IC866-OCH-075-603-20

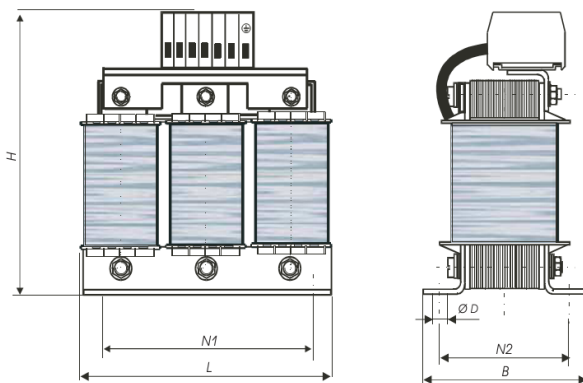
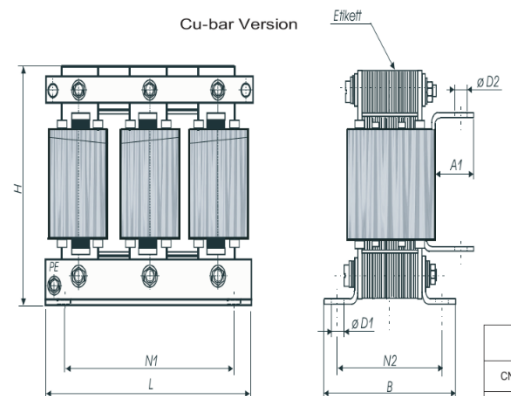

Figure 11: IC866-OCH-180-603-00 through IC866-OCH-300-603-00



3.3 Mounting Dimensions – Enclosed Versions

Part Number	VFD Size	Connection (mm ²)	L (mm)	H (mm)	B (mm)	N1 (mm)	N2 (mm)	ØD (mm)	L1 (mm)	H1 (mm)	B1 (mm)	Rated Volts	Rated Amps	Inductance (mH)	Weight (kg)
IC866-OCH-008-603-60	1	2.5	115	85	74	80	60	5.5 x 7	151	60	85	600 Max	8	2.0	1.7
IC866-OCH-012-603-60	2	2.5	140	110	87	100	70	5.5 x 12	151	60	85		12	1.2	3.2
IC866-OCH-018-603-60	3	10	140	110	87	100	70	5.5 x 12	151	60	85		18	0.9	3.2

Figure 12: Mounting Dimensions – Enclosed Versions

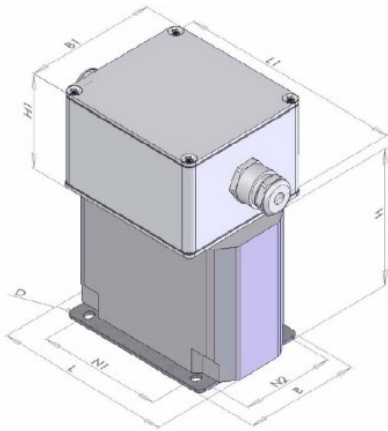

3.4 Installation Schematic Diagram

Figure 13: Installation Schematic Diagram

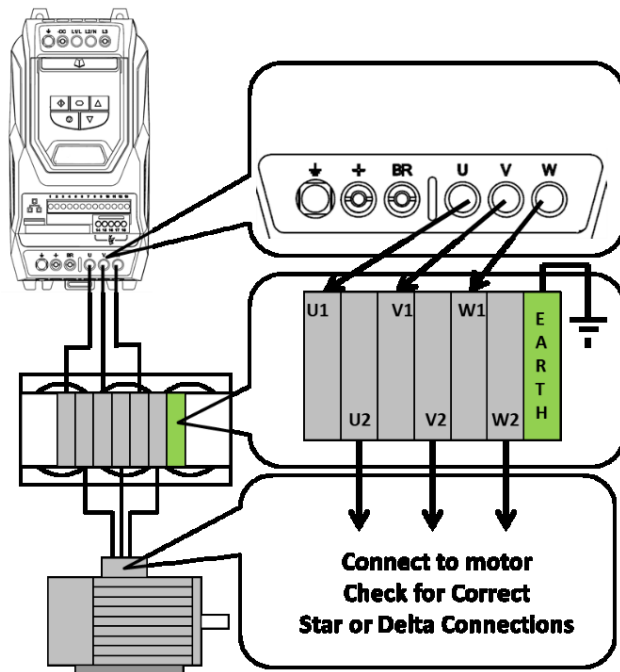

General Contact Information

Home link: <http://www.emerson.com/industrial-automation-controls>

Knowledge Base: <https://www.emerson.com/industrial-automation-controls/support>

Technical Support

Americas

Phone: 1-888-565-4155
1-434-214-8532 (If toll free option is unavailable)

Customer Care (Quotes/Orders>Returns): customercare.mas@emerson.com
Technical Support: support.mas@emerson.com

Europe

Phone: +800-4444-8001
+420-225-379-328 (If toll free option is unavailable)

Customer Care (Quotes/Orders>Returns): customercare.emea.mas@emerson.com
Technical Support: support.mas.emea@emerson.com

Asia

Phone: +86-400-842-8599
+65-6955-9413 (All other Countries)

Customer Care (Quotes/Orders>Returns): customercare.cn.mas@emerson.com
Technical Support: support.mas.apac@emerson.com

Any escalation request should be sent to: mas.sfdcescalation@emerson.com

Note: If the product is purchased through an Authorized Channel Partner, please contact the seller directly for any support.

Emerson reserves the right to modify or improve the designs or specifications of the products mentioned in this manual at any time without notice. Emerson does not assume responsibility for the selection, use or maintenance of any product. Responsibility for proper selection, use, and maintenance of any Emerson product remains solely with the purchaser.

© 2020 Emerson. All rights reserved.

Emerson Terms and Conditions of Sale are available upon request. The Emerson logo is a trademark and service mark of Emerson Electric Co. All other marks are the property of their respective owners.

