

2-12 inch VERIS Accelabar® Installation and Maintenance Manual



Please read and save
these instructions



Contents

General Safety Information	3
Product Information	3
Section 1: Scope	3
Purpose of this Manual	3
Section 2: Receiving and Inspecting	3
Receiving and Inspecting the Accelabar®	3
Section 3: Safety Precautions	
 Safety Messages and Application Requirements	3
Section 4: Installation Preparations	3-4
Location	3
Orientation	4
Horizontal Piping	4
Vertical Piping	4
Section 5: Installation Procedure	5-6
Pipe Preparation	5
Accelabar® Installation	6
Section 6: Sensor and Component Installation	7-9
Packing Installation	8
Packing Bolt Installation	8
Help	9
Section 7: RTD Installation	
RTD Assembly Installation (If Supplied)	10-12
Section 8: Periodic Maintenance	13
Replacing Packing	13
Limited Warranty and Remedy	15

General Safety Information

Instructions and procedures listed in this manual may require special precautions to ensure the safety of the individuals performing the operations. **Review the entire manual, taking note of safety messages prior to performing any operations listed in the manual.**

Product Information

The VERIS Accelabar® is a unique flow meter that combines two differential pressure technologies to produce performance never before attainable in a single flow meter. The VERIS Accelabar® is capable of measuring gases, liquids, and steam at previously unattainable flow rate turndowns—**with no straight run requirements.**

Section 1 Scope

These instructions provide a description of procedures for installing the 2"-12" VERIS Accelabar® model flow sensor and meter body. Procedures are given for all flow measurement applications including liquid, steam and gas in both horizontal and vertical piping orientations.

Section 2 Receiving Inspection

The following tasks should be performed as part of the receiving inspection procedure:

- When removing the Accelabar® from the crate, DO NOT lift the unit from the head of the sensor.
- Check items received against the packing list.
- Check sensor nameplate for proper model number, serial number and tag number.
- Verify the serial number on the sensor nameplate attached to the sensor and body matches that of the serial number on the packing list.
- Check assembly for signs of damage such as a bent flow sensor, or a scratched sealing surface in the flange deeper than allowed by ASME B16.5 (consult VERIS for ASME B16.5 guidelines if needed)

Section 3 Safety Precautions

The following process should be conducted prior to installing the Accelabar®:

- Check the maximum operating conditions on the flow sensor nameplate. Verify that the maximum operating conditions of the application do not exceed the parameters stated on the sensor nameplate. If any pressure, temperature, or flow limits will be exceeded, contact the factory before proceeding.
- Verify enough room available to install the meter (face-to-face and clearance).
- Check to ensure the pipe is depressurized and drained prior to installation.
- The Accelabar® is available in ASME B16.5 Class 150, 300 and 600 and DIN PN 40 and PN 100 configurations; verify the Accelabar® flanges match the required application rating.
- Verify all pressure containing components are properly installed and tightened prior to pressurizing the system.

Section 4 Installation Preparations

4.1 Location

There are no straight run requirements. Allow adequate clearance for manifold, transmitter and sensor removal.

4.2 Orientation

Verify the proper sensor orientation by checking for an “H” (horizontal piping) or a “V” (vertical piping) in the model number on the Accelabar® sensor nameplate. Deviation from the following mounting location instructions may cause inaccuracy in the flow measurement.

4.2.1 Horizontal Piping

For air or gas applications, the Accelabar® must be mounted with the instrument head positioned in the upper 160° position. For liquid and steam applications, the Accelabar® must be mounted with the instrument head positioned in the lower 160° position (See Figure 1).

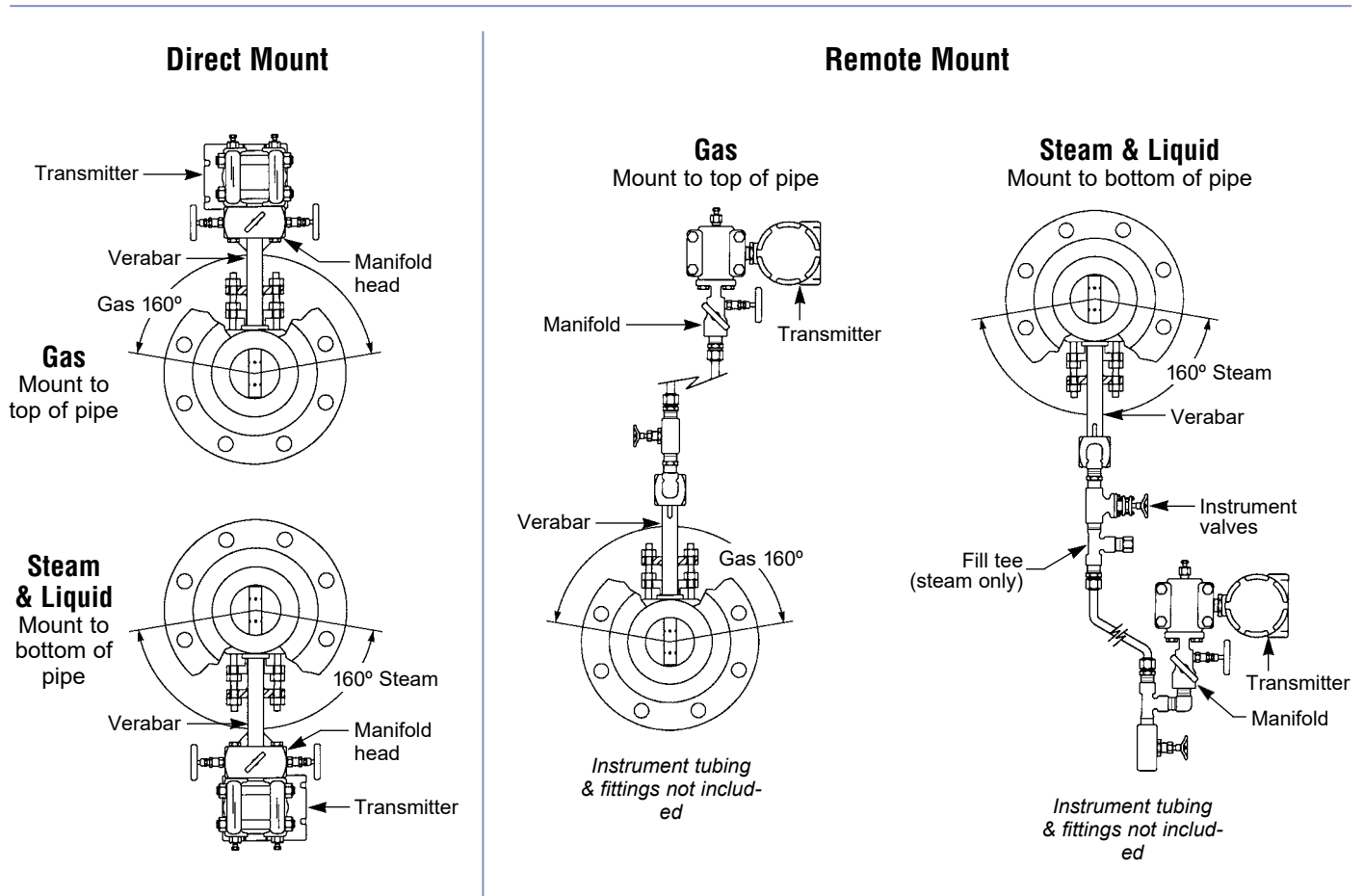

Figure 1. Accelabar® Installation Orientation

4.2.2 Vertical Piping

For vertical applications, the Accelabar® may be mounted in any location around the circumference of the pipe.

Section 5 Installation Procedure



WARNING: Large and heavy Accelabars require support at the unit and piping. Lifting by the instrument head or RTD can cause severe damage to the instrumentation and is NOT recommended.

5.1 Preparing the Pipe

- Completely depressurize and drain the pipe prior to Accelabar® installation.
- Remove a section of the pipe large enough to accommodate the face-to-face flange dimension of the corresponding sized Accelabar® shown in Table 1.

NOTE: The face-to-face dimensions do not include gaskets (see Table 1). VERIS recommends adding 0.375" (9.5mm) to the face-to-face dimension to obtain the required distance between piping flanges.

• IMPORTANT FOR DIRECT MOUNT TRANSMITTER APPLICATIONS:

Locate the Accelabar® to allow adequate clearance for a manifold and transmitter, a minimum of 24" from the centerline of the pipe. Bolt the manifold and transmitter to the Accelabar® to obtain the exact clearance requirements for the given application.

- Weld flanges to existing pipe. Make certain the pipe flanges and Accelabar® flanges are the same Nominal Pipe Size (NPS) and pressure rating. Bolt hole location typically mimics the diagram shown in Figure 2, where bolt holes straddle the centerline of the pipe (Figure 2 does not show 12 and 20 bolt patterns; orientation is typical). However, take into consideration mounting as required in Section 4.0.
- **IMPORTANT:**
Piping must yield slightly to allow the gaskets to crush and seal completely.

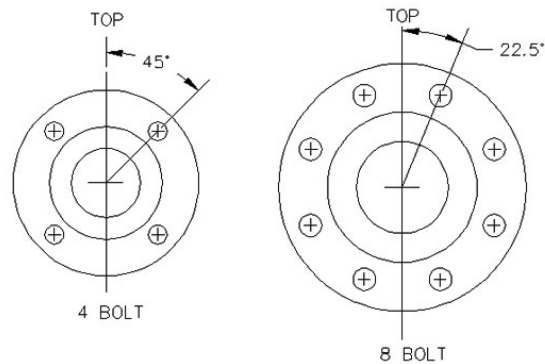

Figure 2. Bolt Hole Orientation

Meter Size	ANSI Rating	Face to Face Dim	Weight
2 inch	150	8.75" (222.25mm)	34lbs (15.42kg)
	300	9.38" (238.13mm)	37lbs (16.78kg)
	600	10.13" (257.18mm)	41lbs (18.60kg)
3 inch	150	13.78" (350.01mm)	40lbs (18.14kg)
	300	14.53" (369.06mm)	53lbs (24.04kg)
	600	15.28" (388.11mm)	53lbs (24.04kg)
4 inch	150	15.15" (384.81mm)	59lbs (26.76kg)
	300	15.90" (403.86mm)	79lbs (35.83kg)
	600	17.65" (448.31mm)	100lbs (45.36kg)
6 inch	150	19.15" (486.41mm)	115lbs (52.16kg)
	300	19.90" (505.46mm)	153lbs (69.40kg)
	600	21.90" (556.26mm)	209lbs (94.80kg)
8 inch	150	21.40" (543.56mm)	193lbs (87.54kg)
	300	22.15" (562.61mm)	247lbs (112.04kg)
	600	24.40" (619.76mm)	333lbs (151.05kg)
10 inch	150	23.15" (588.01mm)	325lbs (147.42kg)
	300	24.40" (619.76mm)	417lbs (189.15kg)
	600	27.65" (702.31mm)	595lbs (269.89kg)
12 inch	150	26.22" (665.99mm)	430lbs (195.05kg)
	300	27.47" (697.74mm)	538lbs (244.03kg)
	600	29.97" (761.24mm)	706lbs (320.24kg)

Table 1. Dimensions

5.2 Accelabar® Installation

- Refer to Figure 1 for proper Accelabar® orientation for horizontal applications (orientation is not critical for vertical applications).
- Position Accelabar® in piping void that has been prepared per dimension in Table 1. Be certain the flow arrow on the Accelabar® is oriented in the same direction as the flow in the pipe. Failure to orient the Accelabar® correctly may result in poor and inaccurate flow measurement.
- Place the appropriate gasket between the pipe flanges and the Accelabar® flanges.
- Insert the flange bolts through the flanges and tighten the nuts, hand-tight, on each end of the bolts. Once all the bolts are hand-tight, tighten opposing sets of bolts until the gasket is crushed. The complete crushed gasket height should be approximately 1/8" (0.125") (3.175mm).

Section 6 Sensor And Component Installation

The Accelabar[®] sensor assembly is factory installed in the meter body with the packing rings in place. The following instructions are intended for replacement sensors, replacement packing rings, or Accelabars with special handling instructions (i.e. O2 service) that require field installation of sensor and packing.

The following instructions describe complete assembly of the Accelabar[®] sensor in the Accelabar[®] meter body.

- **IMPORTANT:** Depressurize and drain the pipe if the Accelabar[®] is installed in the line. 
- Parts necessary for Accelabar[®] are itemized in Table 2. Consult factory for specifications if these items are not factory supplied.

Reference	Part Number	Quantity	Item
1	01139-001	3	SCREW,CAP,SOCKET HEAD,3/8-16UNC x 2.50
2	00120-007	3	BOLT,HEX HEAD,3/8 - 16UNC x 1.50,CLASS 2,316
3	01227-001 (-05)	1	FOLLOWER,05,CASTING,ACCELABAR,CF8M
4	00163-007 (-05)	4	PACKING,05,GRAPH-LOCK,3/4
3	01228-001 (-10)	1	FOLLOWER,10,CASTING,ACCELABAR,CF8M
4	00163-004 (-10)	4	PACKING,10,GRAPH-LOCK
5	00225-002	6	WASHER,LOCK,SPLIT,3/8,316
6	00230-002	2	GASKET,O-RING,MANIFOLD,TEFLON (Direct Mount Only)
7	00430-002	4	BOLT,HEX HEAD,7/16 - 20UNF x 2.00,Gr. 8 (Direct Mount Only)
8	Varies	1	Accelabar [®] Sensor
9	Varies	1	Accelabar [®] Body

Table 2. Accelabar[®] Parts List

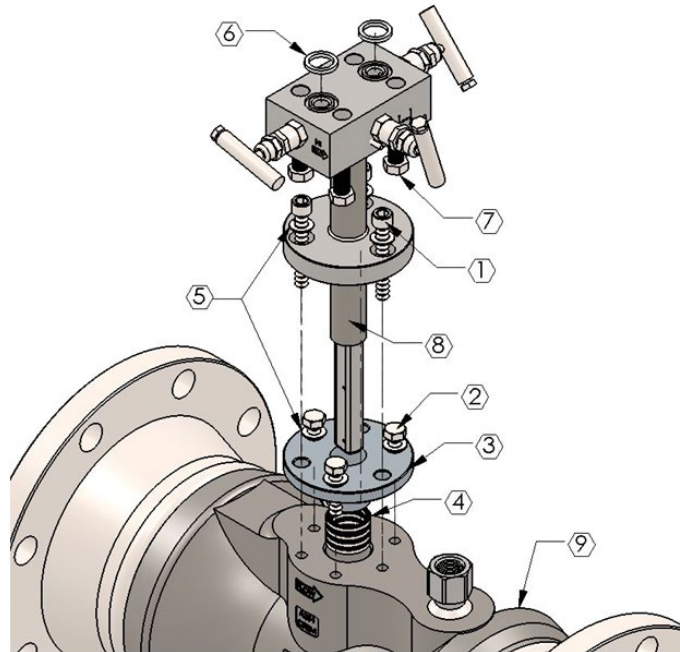

Figure 3. Accelabar® Sensor Assembly

6.1 Packing Installation

Insert a tube fixture (not supplied) or insert the Accelabar® sensor into the bottom bore of the Accelabar® body. Use a 0.75" O.D tube for -05 sensors and a 1.00" O.D tube for -10 sensors. (See Figure 4)

- Using a blunt screwdriver, swage the packing material between the wall of the packing box and the outside diameter of the tube. Care must be taken not to twist the packing material or damage the packing box surface during installation.
- After each individual packing ring is swaged around the tube, the follower should be pushed down firmly on the packing ring to seat the ring in the packing box.
- Repeat steps for the other three packing rings, being sure that the splits in the packing rings are 90° apart as shown in Figure 4.

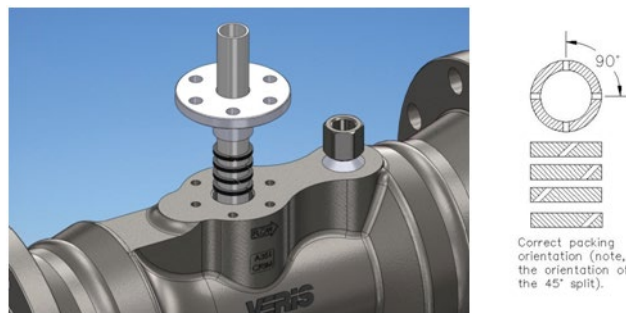

Figure 4. Packing Ring Installation

6.2 Packing Bolt Installation

- Put one split washer on each packing bolt and apply a small amount of anti-seize paste onto the first three to five threads of the packing bolts.
- Install packing bolts per orientation shown in Figure 5, hand tighten.
- Remove tube fixture, if used.

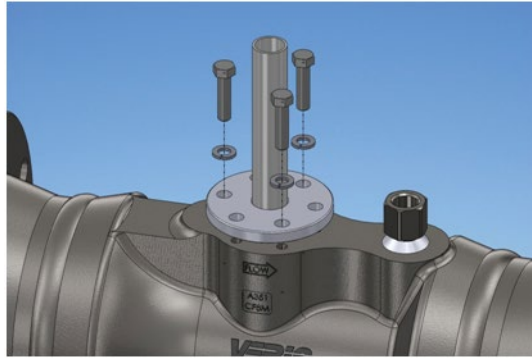
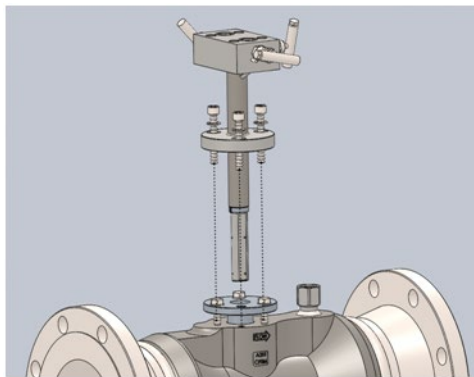

Figure 5. Packing Bolts Installation

6.3 Accelabar® Sensor Installation

- Carefully insert the Accelabar® sensor into the Accelabar® meter body. The sensor can only be inserted in one direction due to the orientation of the mount disk and the packing bolts. Verify direction of the flow arrow on body and sensor match. (See Figure 6)
- Bottom the sensor firmly in the meter body.
- Place one split locking washer onto socket head cap screw and apply Loctite® 262, high strength thread-locking compound. Thread until screw is hand tight, tighten ½ turn beyond hand tight.
- ⚠ • Tighten the socket head cap screws to a torque of 135 inch-pounds (15.25 Nm) on (-05) models and 205 inch-pounds (23.16 Nm) on (-10) models.
- ⚠ • Tighten the packing bolts to a torque of 70 inch-pounds (7.9 Nm) on (-05) models and 100 inch-pounds (11.30 Nm) on (-10) models.



**Figure 6. Sensor installation
(Vertical Orientation shown. Orientation Varies)**

6.4 Help

Contact the factory for installation assistance.

Section 7 RTD Assembly Installation (If Supplied)

NOTE: The 2" RTD is located on the side of the body and the elbow and union are not required.

- Apply thread sealant or tape to the bottom RTD threads and thread into the thermowell. Assure that the RTD is bottomed.
- Apply the same thread sealant to the top RTD threads and thread the union onto the RTD, rotating side up. Tighten the union so that the top does not spin.
- Gently thread the RTD wires through the elbow. Apply the same thread sealant to the elbow threads and thread into union. If necessary, loosen the union and position the elbow so that it points to the side of the body as shown in Figure 7, re-tighten the union.
- Push the RTD wires into the junction box and thread the box onto the elbow in the orientation shown in Figure 7.
- If a cable is supplied, thread it into the junction box and hook up the wires, red-to-red, red-to-red, and white-to-white, refer to Figures 8, 9, or 10. Clip the drain wire (un-insulated) off at the base. R, P, and T heads are typically not supplied with a cable.

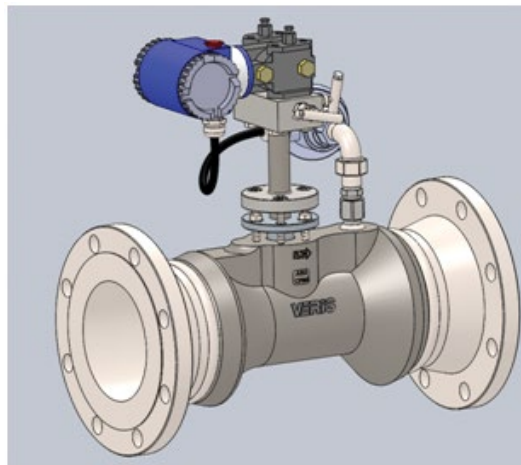

Figure 7. RTD Assembly Orientation

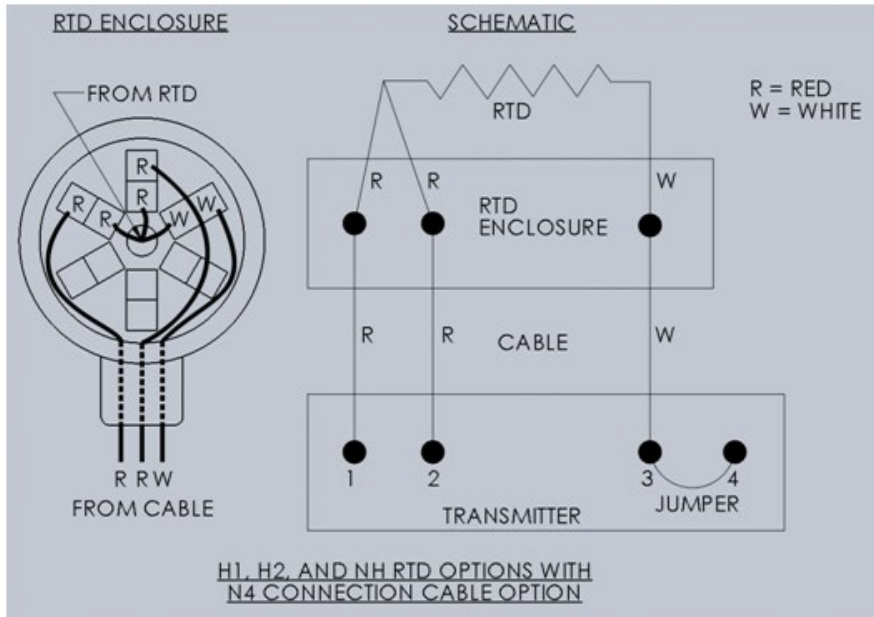

Figure 8. H1, H2, AND NH RTD WITH N4 CABLE

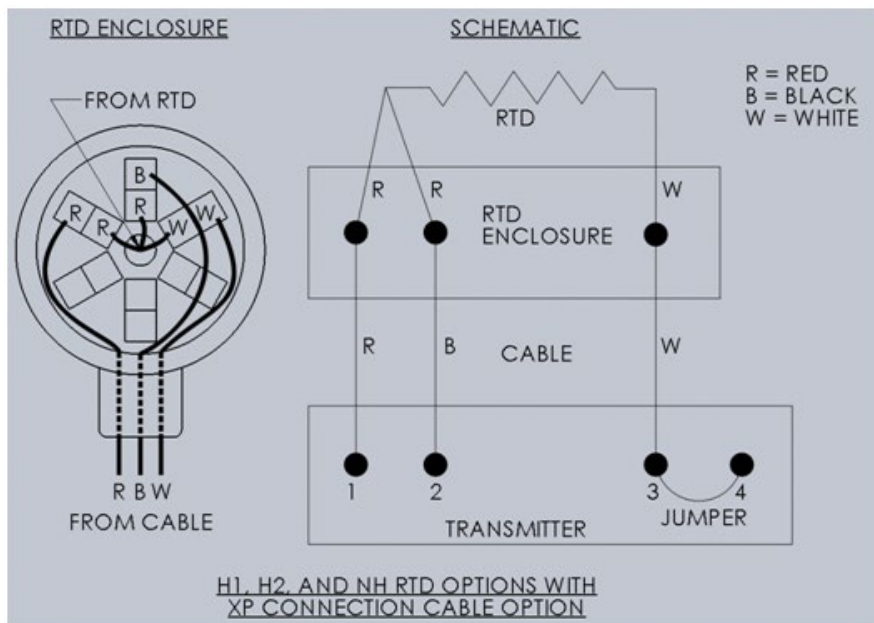

Figure 9. H1, H2, AND NH RTD WITH XP CABLE

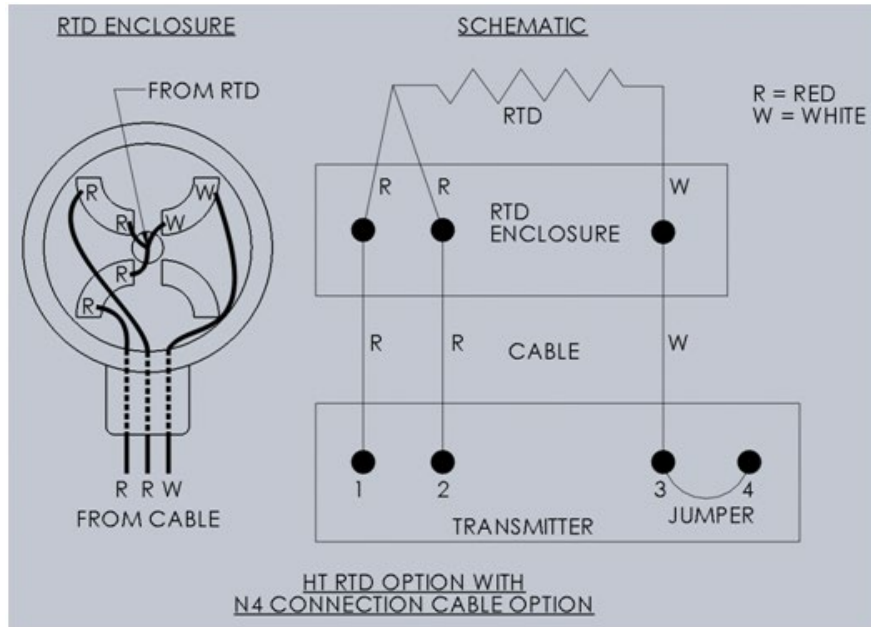



Figure 10. HT RTD WITH N4 CABLE

Section 8 Periodic Maintenance

The assembly should be periodically checked. Verify that no leaks are present. Retaining nuts and packing bolts should be tight.

8.1 Replacing Packing

The following instructions describe removing the Accelabar® sensor from the meter body and replacing the packing rings:

- **IMPORTANT:** Depressurize and drain the pipe. 
- Unbolt and remove transmitter from the Accelabar®, or remove the instrumentation tubing from head.
- Loosen and remove socket head cap screws. (See Figure 6)
- Loosen the follower bolts and gently remove the sensor from the meter body.
- Remove follower bolts and follower from the meter body.
- Carefully remove old packing, taking care in not damaging the surface of the packing box.
- Install new packing and reinstall sensor per procedures described in Section 6.
- Reassemble the transmitter or instrumentation tubing to the sensor head.

VERIS, Inc.

Limited Warranty and Remedy

Veris, Inc. (“Veris”) warrants to the original user of those products supplied by it and used in the service and in the manner for which they are intended shall be free from defects in material and workmanship for a period of five (5) years from the date of installation, but not longer than 63 months from the date of shipment from the Veris factory, unless a Special Warranty Period applies, as noted below. This warranty does not extend to any product that has been subject to misuse, neglect or alteration after shipment from the Veris factory. Except as may be expressly provided in a written agreement between Veris and the user, which is signed by both parties, Veris **DOES NOT MAKE ANY OTHER REPRESENTATIONS OR WARRANTIES, EXPRESS OR IMPLIED, INCLUDING, BUT NOT LIMITED TO, ANY IMPLIED WARRANTY OF MERCHANTABILITY OR ANY IMPLIED WARRANTY OF FITNESS FOR A PARTICULAR PURPOSE.**

The sole and exclusive remedy with respect to the above limited warranty or with respect to any other claim relating to the products or to defects or any condition or use of the products supplied by Veris, however caused, and whether such claim is based upon warranty, contract, negligence, strict liability, or any other basis or theory, is limited to Veris’ repair or replacement of the part or product, or, at Veris’ option, to repayment of the purchase price. In addition to replacing any part of parts found to Veris’ satisfaction to be defective, Veris will pay the cost of shipment of both the defective part to the Veris plant and the replacement part to the original user. As a condition of enforcing any rights or remedies relating to Veris products, notice of any warranty or other claim relating to the products must be given in writing to Veris: (i) within 30 days of last day of the applicable warranty period, or (ii) within 30 days of the date of the manifestation of the condition or occurrence giving rise to the claim, whichever is earlier. **IN NO EVENT SHALL VERIS BE LIABLE FOR SPECIAL, DIRECT, INDIRECT, INCIDENTAL OR CONSEQUENTIAL DAMAGES, INCLUDING, BUT NOT LIMITED TO, LOSS OF USE OR PROFITS OR INTERRUPTION OF BUSINESS.** The Limited Warranty and Remedy terms herein apply notwithstanding any contrary terms in any purchase order or form submitted or issued by any user, purchaser, or third party and all such contrary terms shall be deemed rejected by Veris.

Special Warranty Periods are as follows:

Vortex Shedders, Venturi, Orifice Plates, Flow Nozzles and Wedge Meters: one (1) year from the date of installation, but not longer than 15 months from the date of shipment from the Veris factory.

Electromagnetic Flow and BTU Meters, Ultrasonic Flow and BTU Meters: 21 months from the date of installation, but not longer than 24 months from the date of shipment from the Veris Factory.

Electronic components, including without limitation, differential pressure transmitters, multivariable transmitters, flow computers, rate or totalizer displays: one (1) year from the date of installation, but not longer than 15 months from the date of shipment from the Veris factory.

2-12 inch VERIS Accelabar[®] Installation and Maintenance Manual

*Designs, materials, weights and performance ratings are approximate and subject to change without notice.
Visit armstronginternational.com for up-to-date information.*



Armstrong International - VERIS Flow Measurement Group
5820 Glacier Way, Frederick, CO 80205 - USA Phone: 303-652-8550 Fax: 303-652-8552
armstronginternational.com