

# HYDRAULIC SYSTEM TEST ANALYZER

Hydraulic Test Analyzer is used to diagnose faults in hydraulic circuits, determine horsepower and test for component wear and cylinder leakages. Two options are available: K Series (flow & pressure) and T Series (flow, pressure & temperature).

## TECHNICAL SPECIFICATIONS

### Measuring Accuracy

Flow:  $\pm 2\%$  of full scale  
 Pressure:  $\pm 2.5\%$  of full scale  
 Temperature:  $\pm 2.5\%$  of full scale

### Repeatability

$\pm 1\%$  of full scale - all measurements

### Flow Measuring Range

Flow: 0.1-150 GPM (0.5-550 LPM)  
 Temperature: 0-250°F (-20-120°C)

### Maximum Operating Pressure

Aluminum meters: 3000 PSIG (200 Bar)  
 Stainless steel meters: 5000 PSIG (340 Bar)

### Maximum Operating Temperature

240°F (116°C)

### Standard Calibration Fluid

Oil meters: DTE 25® @ 110°F (43°C),  
 0.873 sg

### Filtration Requirements

74 micron filter or 200 mesh screen minimum

### Viscosity

Standard viscosities up to 110 cSt.

DTE 25 is a registered trademark of Exxon Mobil.

## MATERIALS OF CONSTRUCTION

Wetted Components		Non-Wetted Components	
Component	Materials	Component	Materials
Needle Valve	Carbon Steel	Window Tube	Polycarbonate
Casing and End ports	Anodized Aluminum (3000 PSIG) Stainless Steel (5000 PSIG)	Window Tube Seals	Buna-N®
Seals	Buna-N® (STD), FKM, EPR, Neoprene optional	Gauge	Brass and Stainless Steel
Transfer Magnet	PTFE coated Alnico	Gauge Window	Acrylic
All other internal parts	Stainless Steel		

Buna-N is a registered trademark of Chemische Werke Huls.



## BENEFITS

### A Complete Troubleshooting System

Style K consists of the flow meter, precision needle-type load valve and Glycerin filled pressure gauge. Style T adds a Thermowell protected temperature gauge.

### Planned Component Repairs

This system analyzer can be part of a predictive maintenance program, allowing strategized pump, valve, motor and cylinder rebuilding.

### Compact and Rugged

The complete hydraulic system test analyzer is small enough to fit in a tool box and built to withstand rigorous industrial use.

### Non-Electrical

Without batteries to fail or other electrical power connections to make, this system will provide a lifetime of simple and reliable operation.

### Metric and US/Standard Measuring Ranges

These multi-measurement analyzers simultaneously measure flow in GPM and LPM, pressure in PSIG and Bar, and temperature in degrees F and C.

### Unrestricted Mounting

Accurate measurements can be taken in any mounting orientation, without the straight plumbing required with other analyzer systems.

### Reverse Flow Option Available

Optional built-in reverse bypass mechanism prevents potential damage from mis-installation or backflow.

# HYDRAULIC SYSTEM TEST ANALYZER

Hydraulic Test Analyzer is used to diagnose faults in hydraulic circuits, determine horsepower and test for component wear and cylinder leakages. Two options are available: K Series (flow & pressure) and T Series (flow, pressure & temperature).

## HYDRAULICS DIAGNOSTICS TOOL KIT APPLICATIONS

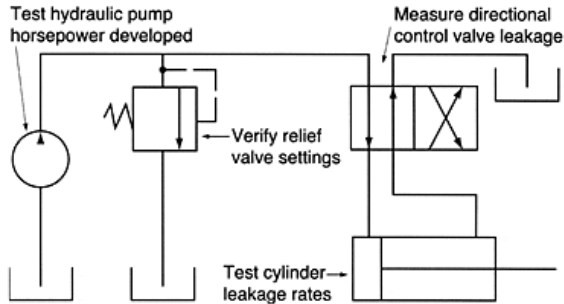

## K-STYLE

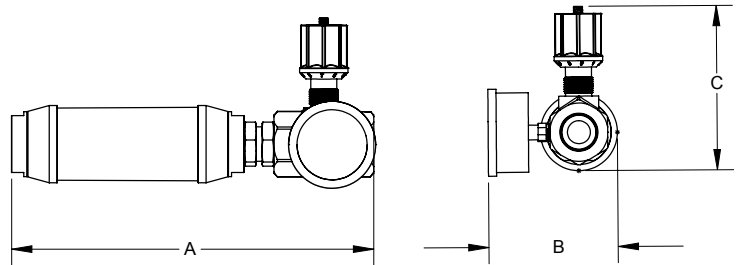

## T-STYLE

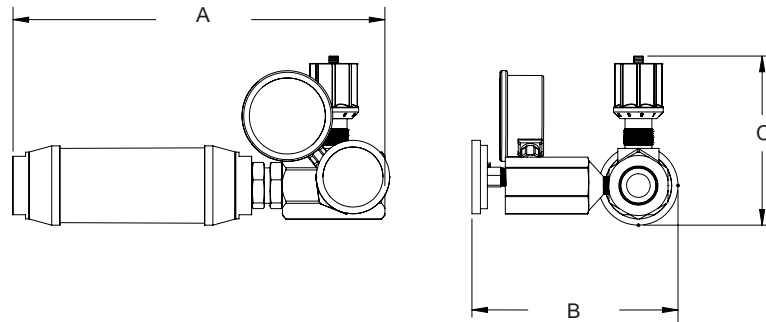
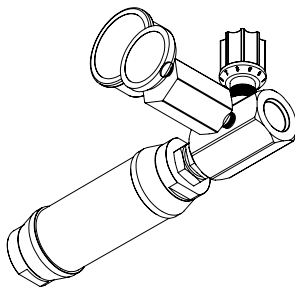

## GENERAL DIMENSIONS

(Measurements may vary from meter to meter)

DIM	Series 3	Series 3	Series 4	Series 4	Series 5	Series 5
Port Sizes	3/8" + #6 SAE	1/2" + #8 SAE	3/4" + #12 SAE	1" + #16 SAE	1-1/4" + #20 SAE	1-1/2" + 24 SAE
A	9.75" (248mm)	10.15" (258mm)	11.14" (283mm)	12.7" (323mm)	15.85" (403mm)	15.85" (403mm)
B (K-Style)	3.44" (87mm)	3.54" (90mm)	3.98" (101mm)	4.08" (104mm)	4.84" (123mm)	5.04" (128mm)
B (T-Style)	5.64" (143mm)	5.74" (146mm)	6.18" (157mm)	6.28" (160mm)	7.04" (179mm)	7.24" (184mm)
C	4.11" (104mm)	4.53" (115mm)	5.07" (129mm)	5.88" (149mm)	6.64" (169mm)	6.84" (174mm)

Products may be subject to change without notice - Contact factory for the most up-to-date product information.

# HYDRAULIC SYSTEM TEST ANALYZER

Hydraulic Test Analyzer is used to diagnose faults in hydraulic circuits, determine horsepower and test for component wear and cylinder leakages. Two options are available: K Series (flow & pressure) and T Series (flow, pressure & temperature).

## PART NUMBER GUIDE



### HYDRAULIC TEST ANALYZERS

Temperature & Pressure =   
 Pressure =

### PORT SIZE RANGE

3/8" - 1/2" =   
 3/4" - 1" =   
 1-1/4" - 1-1/2" =

### MATERIAL

Aluminum =   
 Stainless Steel =

### MAX. PRESSURE RATING

3000 psig (liquids & aluminum) =   
 5000 psig (liquids, stainless steel) =

### FLUID MEDIA

Oil & 0.873 specific gravity =

Note: For special scales consult factory.

### PORTING/THREAD TYPE

(all female)	<b>Size</b>	
1/4" NPTF, dry seal	3 only =	<input type="text" value="S"/>
3/8" NPTF, dry seal	3 only =	<input type="text" value="A"/>
1/2" NPTF, dry seal	3 only =	<input type="text" value="B"/>
3/4" NPTF, dry seal	4 only =	<input type="text" value="C"/>
1" NPTF, dry seal	4 only =	<input type="text" value="D"/>
#6 SAE, O-ring seal	3 only =	<input type="text" value="E"/>
#8 SAE, O-ring seal	3 only =	<input type="text" value="F"/>
#12 SAE, O-ring seal	4 only =	<input type="text" value="H"/>
#16 SAE, O-ring seal	4 only =	<input type="text" value="J"/>
1-1/4" NPTF, dry seal	5 only =	<input type="text" value="K"/>
1-1/2" NPTF, dry seal	5 only =	<input type="text" value="L"/>
#20 SAE, O-ring seal	5 only =	<input type="text" value="N"/>
#24 SAE, O-ring seal	5 only =	<input type="text" value="P"/>

### SPECIAL SCALE/CUSTOM PRODUCT

### OPTIONAL FLOW DIRECTIONS

Standard Flow, Uni-Directional =    
 Reverse Flow =

### FLOW RANGES

Liquid		Size
0.1-1.0 GPM	0.5-4 LPM	3 only = <input type="text" value="0"/> <input type="text" value="1"/>
0.2-2.0 GPM	1-8 LPM	3 & 4 = <input type="text" value="0"/> <input type="text" value="2"/>
0.5-5.0 GPM	2-19 LPM	3 & 4 = <input type="text" value="0"/> <input type="text" value="5"/>
1-10 GPM	5-37.5 LPM	3 & 4 = <input type="text" value="1"/> <input type="text" value="0"/>
1-15 GPM	5-55 LPM	3 & 4 = <input type="text" value="1"/> <input type="text" value="5"/>
2-20 GPM	10-75 LPM	4 only = <input type="text" value="2"/> <input type="text" value="0"/>
2-25 GPM	10-95 LPM	4 & 5 = <input type="text" value="2"/> <input type="text" value="5"/>
4-30 GPM	15-115 LPM	4 only = <input type="text" value="3"/> <input type="text" value="0"/>
4-40 GPM	20-150 LPM	4 only = <input type="text" value="4"/> <input type="text" value="0"/>
6-50 GPM	20-190 LPM	4 & 5 = <input type="text" value="5"/> <input type="text" value="0"/>
6-75 GPM	30-280 LPM	5 only = <input type="text" value="7"/> <input type="text" value="5"/>
10-100 GPM	50-375 LPM	5 only = <input type="text" value="8"/> <input type="text" value="8"/>
25-150 GPM	100-550 LPM	5 only = <input type="text" value="9"/> <input type="text" value="9"/>

Products may be subject to change without notice - Contact factory for the most up-to-date product information.