



EXPERTS IN WATER CHEMISTRY SINCE 1903



2410 Oil in Water Analyzer Instruction Manual

101-026-A.2

OUR COMMITMENT TO OUR CUSTOMERS

This instruction manual is a technical guide to aid the customer in the set-up, operation, and maintenance of their new Waltron measuring system. Waltron provides continuous product improvement and reserves the right to make any modifications to the information contained herein without notice.

*Copyright © Waltron Bull & Roberts, LLC, 2022
All Rights Reserved*

Technical questions concerning this product should be addressed to:

Waltron Technical Service Department
Flemington, New Jersey
Phone: (908)-534-5100
Fax: (908)-534-5546
www.waltron.net

Please be ready to provide the following information:

- Date analyzer was purchased
- Analyzer model and serial number
- Recent maintenance history
- Calibration slope values and detailed description of problem

Waltron's technical expertise and extensive experience provides personalized solutions to the water quality industry. It is Waltron's commitment to provide the customer with timely and accurate technical service and support.

Waltron fully expects the customer to be satisfied with the quality, performance, and cost of this product.

If there are any questions or concerns regarding this product, please feel free to contact Waltron at (908)-534-5100.

Thank you for choosing Waltron!

Please note the Waltron mailing and shipping address:

Waltron Bull & Roberts, LLC
25 Minneakoning Road, Suite 101
Flemington, NJ 08822

Please observe proper safety and handling precautions when installing, operating, maintaining, and servicing this product. The following should be noted and adhered to:

- √ This instruction manual should be carefully read before proceeding.
- √ Warning labels on enclosures, containers, packages and chemicals must be abided by.
- √ Only qualified personnel that have been trained in accordance to the information provided should be involved in the installation, operation, and servicing of the analyzer.
- √ To avoid accidents from occurring, normal safety precautions must be followed when operating the analyzers in conditions of high pressure and/or temperature.
- √ The chemicals that are used to operate this machine must be stored away from heat, protected from temperature extremes and powders kept dry.
- √ Follow all regulations and warning labels when disposing of chemicals. Do not mix the chemicals together.

To obtain analyzer safety information or Safety Data Sheets (SDS), please contact Waltron or visit the website at www.waltron.net .

If, within one year from the date of shipment, the customer experiences any equipment defects or is not satisfied with the analyzer manufacturing, Waltron will repair, or at its option, replace any defective part(s) free of charge. This warranty requires that the defective part(s) be returned to Waltron with shipping charges prepaid.

At Waltron discretion, a Technical Service Specialist may be sent out to repair or replace the defective part(s) on location. Traveling time and expenses of the Technical Service Specialist is at the customer's expense.

Equipment sent to Waltron must be appropriately packaged and the following information must be provided prior to returning to Waltron:

- The Return Authorization (RA) number assigned to the customer by the Waltron Technical Service Department
- Customer name, address and department
- Name and telephone number of the individual responsible for returning items for repair
- Brief problem description

Ship to Waltron service center:

Waltron Bull & Roberts, LLC
25 Minneakoning Road, Suite 101
Flemington, NJ 08822

The Waltron Warranty Agreement:

- Covers expendable sensors for one month after shipment and reusable electrodes for six months after shipment.
- Does not apply to damages occurred during shipping.
- Warranty will be nullified if goods have been used for purposes other than those for which they are intended or if any seal has been removed, broken or tampered with or if the Waltron trademark or serial number has been removed, defaced, or altered.
- Does not cover expendable supply items such as reagents, tubing and electrolytes.
- Does not cover misuse or mistreatment by the user.
- Does not cover previous repair or alteration by unauthorized individuals.

Waltron does not assume responsibility for contingent liability through alleged failure or failures of products or product accessories.

Waltrons' concern does not stop when your instrument leaves our loading dock. We want to thank you for your confidence in Waltron., our product, and the service that we provide. We want to make sure that your experience with us will be one of total satisfaction starting with the condition in which you have received your product.

- √ Inspect all shipping containers upon receipt and record any visible damage. Count the number of packages, making sure that the number is in agreement with the shipping paperwork. If there are any outward signs of damage, please retain all containers and packages for inspection by carrier. It is generally good practice to retain the packing material and boxes as they make an excellent way to protect the instrument if you move it or ever need to ship the instrument.
- √ Make sure that all items received match the packing list. If you ordered chemicals, they are usually shipped in a separate package and will be itemized accordingly.
- √ Verify that the number of packages received agrees with the package list and shipping papers.
- √ Notify both Waltron and the carrier, if any problems occur.

Important Notice

- √ All Monitors in our range are inspected and tested prior to shipment
- √ In normal use the units should operate correctly and without fault over a long period of time requiring only minor maintenance, which should only be carried out as outlined in this manual.
- √ If electronic components are replaced, please note that due to varying component characteristics it may be necessary to re-adjust or calibrate the monitor.
- √ Failure to carry out correct maintenance procedures could result in the monitor over or under reading, which in turn could lead to oil pollution and the consequences that follow.

Section	Contents	Page
1	Introduction	8-9
	1.1 General Description/ Principle of Operation	8
	1.2 Mechanical Characteristics	9
2	Installation and Mounting	10-13
	2.1 Mounting and Layout	10
	2.2 Wiring	11-12
	2.3 External Piping Connections	13
3	Start-up	14-17
	3.1 Commissioning—User Interface Guideline	14
	3.11 Pre-Commissioning	15
	3.2 Setting Alarm Points	16
	3.3 Setting Alarm Delays	16
	3.4 Calibrating for Clean Water	17
	3.5 Output Range Selection	17
4	Operating Instructions	18
	4.1 Operating Instructions	18
5	Routine Maintenance	19
	5.1 Operator Maintenance	19
6	Troubleshooting	20
	6.1 Troubleshooting Guideline	20
7	Specifications	21
	7.1 Technical Specifications	21
8	Auto Clean System (where Fitted)	22
	8.1 Auto Clean System	22 -23
	8.2 Auto Clean Terminal Enclosure	24
	8.3 Auto Clean Cycle Frequency	25
9	Spare Parts Listing	26
	9.1 Recommended Spare Parts/ Other Spare Parts	26
10	Operator's Notes	27-30

1.1 General Description—Principle of operation

The μAI-2410 Oil in Water Analyzer is a continuous online monitor for direct measurement of oil or other hydrocarbons in sample streams in concentrations between 0-99ppm. A set of optical sensors measures a combination of light scattered and absorbed by oil droplets in the sample stream and converts the mV signals to concentration values using a microprocessor. The microprocessor drives voltage outputs, current outputs, two seven segment displays, six light emitting diodes, two oil alarm relays, and one fault relay.

In addition, the microprocessor checks the condition of the sensor components and calibration verification to ensure accuracy is maintained over time and in various environmental conditions.

Self-Diagnostic information is visually displayed as both the alarm status indicators and fault indicators are set to Red. Furthermore this information can be relayed through both the fault relay and alarm relay contacts. An error code will be displayed on the display relating the fault identity.

1.2 Mechanical Characteristics

The system is composed of two components; a sample chamber assembly and an electronic control unit (transmitter). (See figure below). The sample chamber assembly consists of a cell cap (5), sample inlet, sample outlet, desiccators, and throttle. The sample chamber assembly contains the measuring cell and is a sealed unit set to the right hand side of the enclosure. The inlet pipe is situated on the bottom of the cell (8) and the outlet pipe is situated on the top right hand side of the cell (3). A desiccator (7) to eliminate moisture around the outside of the glass tube and a throttle (6) to regulate flow and maintain pressure are also fitted to the cell. The electronic control unit contains two printed circuit boards; the display board (2) is mounted to the front cover, which provides the PPM display (4) and the six light emitting diodes. The motherboard (1) is mounted to the back of the enclosure and contains the power supply, alarm relays, digital to analog and amplification circuitry. The front of the monitor is fitted with a membrane user interface containing three push buttons (9), and windows for the LED displays.

Figure 1.2: Construction Configuration

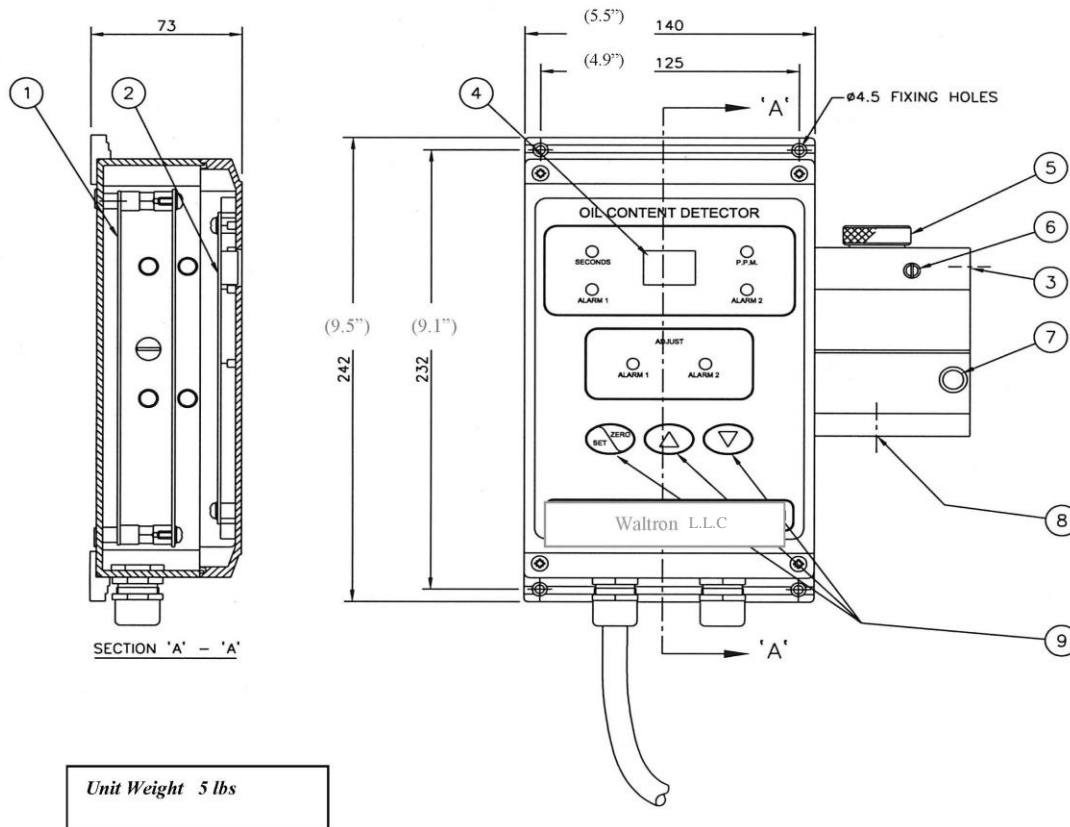

2.1 Mounting and Location

- Mount the sensor and transmitter units in a clean, vibration-free area, avoiding direct radiant heat, sunlight and drafts. Avoid areas containing chlorinating equipment.
- Mount the μAI-2410 by means of 4 x M4 screws on to a rigid vertical surface and preferably with the display panel of the monitor at eye level.
- The location of the monitor should be located in close proximity to the sample point to minimize response delays.

FIGURE 2.1 MOUNTING ARRANGEMENTS

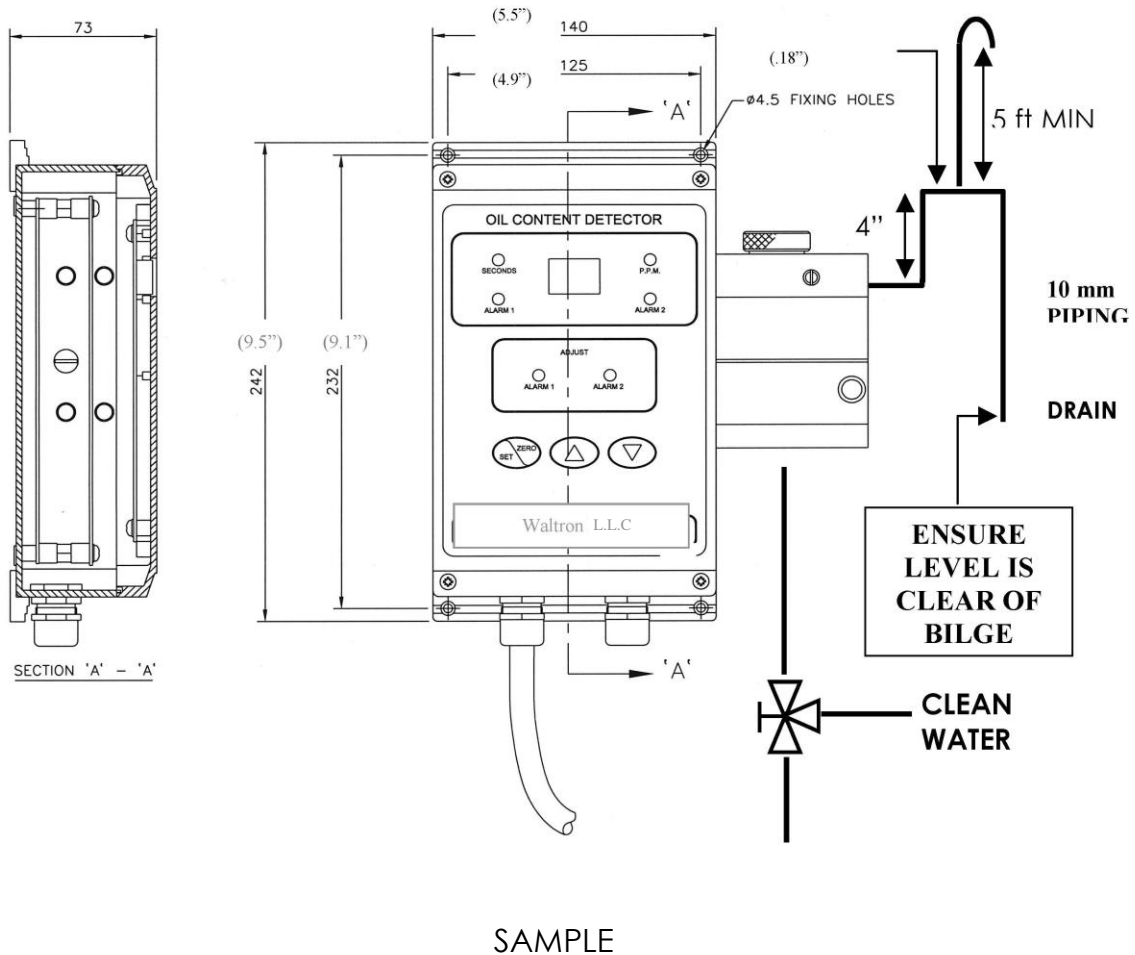

2.2 Wiring (refer to figure 2.2)

- This unit must be connected to the power supply via a suitably rated and approved double pole fused isolator unless such fusing/isolation is provided by associated equipment. When fitted, the isolator should be close by, readily accessible and marked as to function.
- Cable entries can accept cables from 6 to 12 mm diameter. The terminal block will accept cable cores of up to 4mm² and cables carrying hazardous voltages must be at least .75mm² csa. When terminating mains cabling at monitor and electrical source, the ground conductor must be made longer than the live and neutral conductors.
- To select between 230V and 115V supply a link (or two in case of 110V), is attached on JP1 and JP2 in the relative formations shown on figure 2.2. The link must be electrically insulated and at least .50 mm csa.
- Note to make connections to J11, J12, JP1, and JP2 terminals may be pulled out of PCB connections via tags or links provided.
- Connections to the cables should be made as shown on Figure 2.2.
- Precise wiring details will vary depending upon the control system to be employed but the most frequently used systems employ Alarm relay 1 for control purposes and Alarm relay 2 for alarm annunciation only.

⊗ WARNING.

Although some instruments have internal fuse protection, you must use a suitably rated external protection device, such as a fuse or miniature circuit breaker (MCB).

Switch **OFF** the power supply and high voltage power-operated control circuits before making any connections.

This equipment operates on alternating current electricity. Always take suitable safety precautions to avoid the possibility of an electric shock.

Figure 2.2: Terminal Connections and Wiring

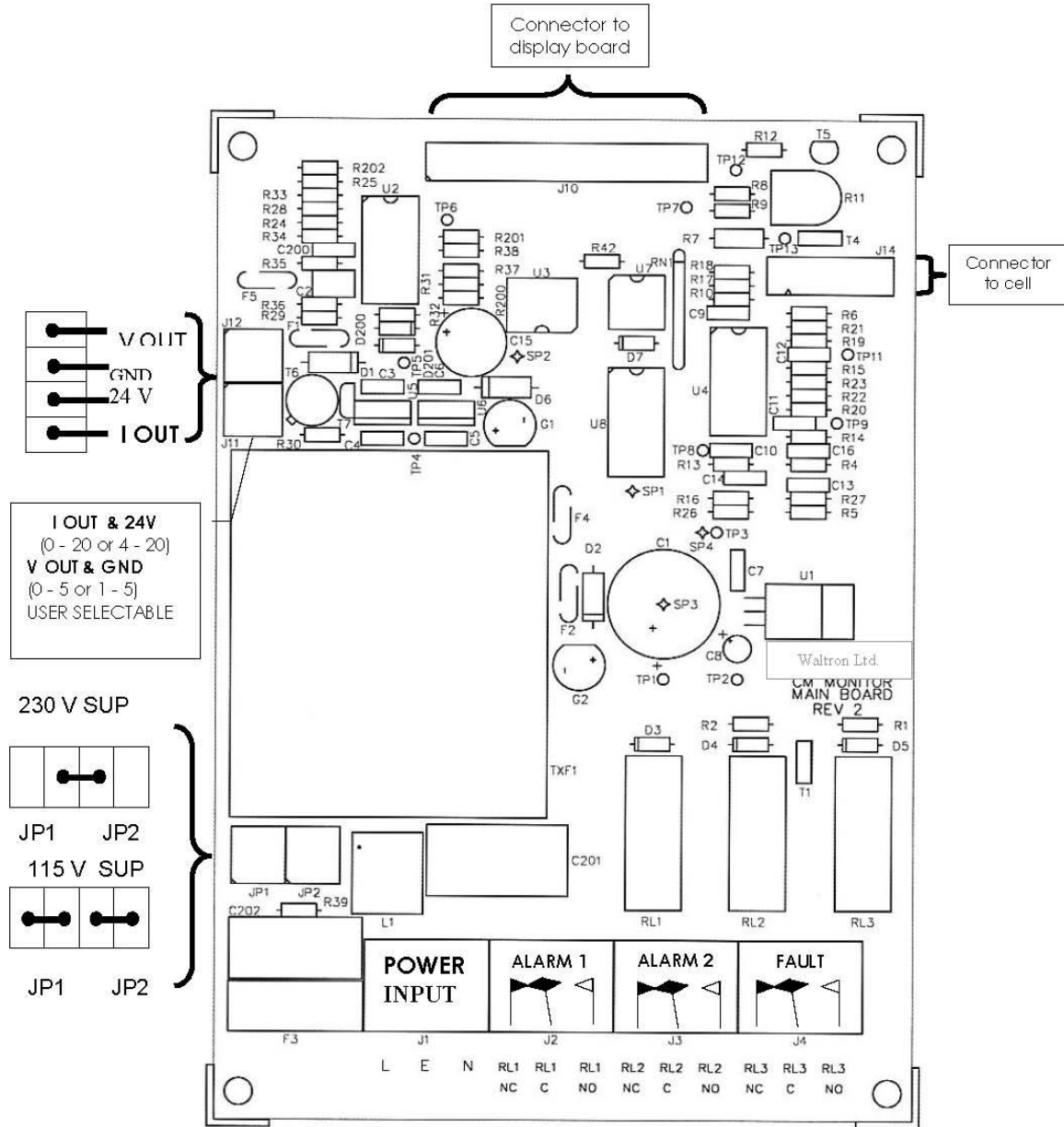

2.3 External Piping Connections

⊗ **WARNING.**

Do not exceed the maximum pressures and temperatures specified. If you use pressure-reducing equipment, install a pressure relief valve between your equipment and the sample inlet to the monitor for safety purposes.

- √ Install piping (10mm) according to sample requirements from sample line into a “T-Valve” with *clean water (oil-free)* as second source
- √ From output of T-valve, install piping to inlet of sample chamber (bottom) using a ¼” BSPP inlet fitting.
- √ From outlet of sample chamber, install drain-entrainment loop as shown in Figure 2.1 to appropriate drain
- √ Check all piping connections for leaks and rectify as appropriate

⊗ **IMPORTANT!**

Clean Water (Free of any Hydrocarbons) will be used to calibrate the instrument and for cleaning purposes and therefor is imperative to have clean water piped into the T-Valve for this procedure.

3.1 Commissioning Figure

3.1: User Interface Guideline

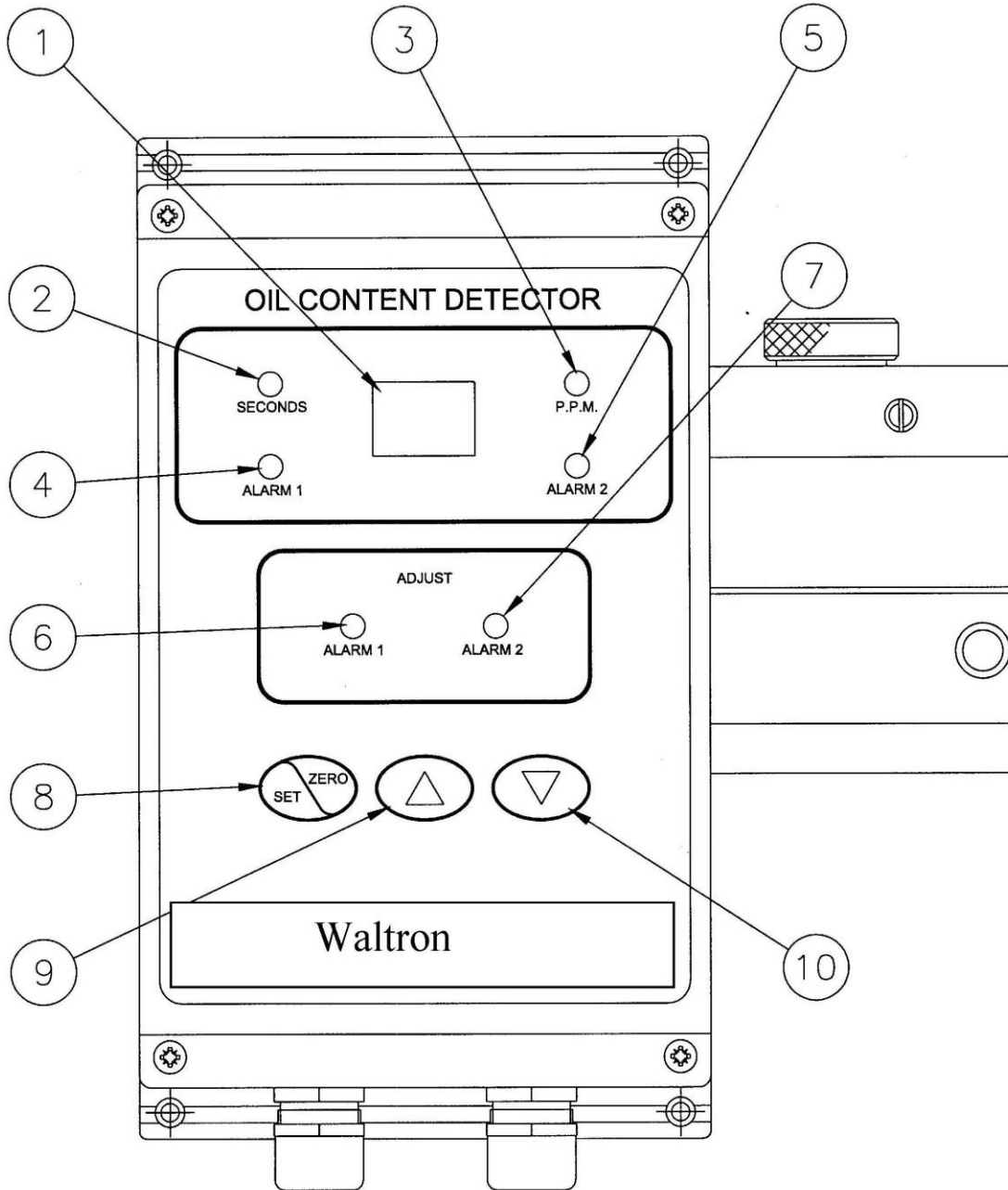

3.11 Pre-Commissioning

On completion of the installation, wiring and piping carry out the following checks:

Electrical:

- √ Check that the power supply voltage on cables 1 and 2 are within limits
- √ Check to confirm that a good connection to ground has been made.

Piping:

- √ Check all piping connections for leaks and rectify as appropriate. **Functional Tests (refer to Fig 3.1)**

- √ Turn the supply voltage to the Monitor on, the display (1) should read **FC** (Factory Calibration) for 3 Seconds. (*Note this will only change to **CC** if a full-scale calibration is performed outside factory conditions).

- √ The monitor will then run through a self-diagnostics and initialization routine. During this time the display will count down from 40 to 0 and back up to 40 again. Alarm LED's will extinguish & illuminate at alarm set points.

- √ Run oil-free water through the instrument for a short period to purge the system of air and dirt.

- √ Adjust the throttle screw in the cell cap so that the flow rate through the cell is between 0.5 and 2 liters/min. Note: the flow rate should be checked on both the clean water supply and the separator sample supply. If the clean water supply is obtained from a high pressure source, it may be necessary to restrict this at a point up-stream of the clean water/sample 3 way selector valve.

- √ Switch the clean water supply to the instrument and after 2 minutes set zero in accordance with the Operating Instructions (**see sect 3.4**).

- √ Set-up the monitor to give a 0 – 5V analog output and connect a voltmeter (**see sect 3.5**). The reading should not vary by more than + 0.25v above zero (equivalent to + 1.5ppm). If the reading varies by a greater amount, air entrapment is almost certainly present and changes to the sample piping or sampling take-off point may be necessary.

3.2 Setting Alarm points (refer to Fig 3.1)

Alarm 1 and alarm 2 are both factory set to 15 PPM. To adjust these points the following procedure should be followed.

To adjust alarm 1 set point:

- √ Press & release the DOWN or UP KEY (**10 or 9**) repeatedly until the PPM LED (**3**) and the ALARM 1 ADJUST LED (**6**) are both on, the alarm 1 PPM set point is now displayed.
- √ Press & release the SET/ZERO KEY (**8**). Adjust the PPM value by pressing the UP or DOWN KEY (**10 or 9**) until the desired value is displayed.
Acknowledge the desired value by pressing and releasing the SET/ZERO KEY (8)

To adjust alarm 2 set point:

- √ Press & release the DOWN or UP KEY (**10 or 9**) repeatedly until the PPM LED (**3**) and the ALARM 2 ADJUST LED (**7**) are both on, the alarm 2 PPM set point is now displayed.
- √ Press & release the SET/ZERO KEY (**8**). Adjust the PPM value by pressing the UP or DOWN KEY (**10 or 9**) until the desired value is displayed.
Acknowledge the desired value by pressing and releasing the SET/ZERO KEY (8)

3.3 Setting Alarm delays (refer to Fig 2.2.)

Alarm 1 and alarm 2 delays are factory set to 0 and 10 seconds respectively. To adjust these delays the following procedure should be followed.

To adjust alarm 1 delay:

- √ Press & release the DOWN or UP KEY (**10 or 9**) repeatedly until the SECONDS LED (**2**) and the ALARM 1 ADJUST LED (**6**) are both on. The alarm 1 delay is now shown on the display (**1**).
- √ Press & release the SET/ZERO KEY (**8**). Adjust the SECONDS value by pressing the UP or DOWN KEY (**10 or 9**) until the desired value is displayed. **Acknowledge the desired value by pressing and releasing the SET/ZERO KEY (8)**

To adjust alarm 2 delay:

- √ Press & release the DOWN or UP KEY (**10 or 9**) repeatedly until the SECONDS LED (**2**) and the ALARM 2 ADJUST LED (**7**) are both on. The alarm 2 delay is now shown on the display (**1**).
- √ Press & release the SET/ZERO KEY (**8**). Adjust the SECONDS value by pressing the UP or DOWN KEY (**10 or 9**) until the desired value is displayed. **Acknowledge the desired value by pressing and releasing the SET/ZERO KEY (8)**

Note ALARM 2 DELAY is shown in multiples of ten (e.g. display reads 9 but the delay is 90 seconds)

3.4 Calibrating for clean water (refer to Fig 3.1)

- √ Insure that there is no flow through the cell. Remove the cell cap and clean the inside of the cell tube with bottlebrush provided. Replace the cell cap
- √ To calibrate the monitor to local clean water ensure that clean water is passing through the measuring cell then press & hold the SET/ZERO KEY **(8)** for **3 seconds** in PPM monitor mode (i.e. LEDS **2,4,5,6** and **7** are all off)
- √ The display (1) will flash alternately CL and blank for **8 seconds** after which the display will read 0 PPM
- √ If calibration was not successful **bC** will appear on the display. To clear this error simply press the SET/ZERO KEY, and the original calibration will be retained.

3.5 Output range Selection (refer to Fig 2.2)

- √ To select the output range, the correct cable connections should be made first
- √ If an output range of 0 – 20 mA or 4 – 20 mA is required wires **I OUT** and **24V** should be connected on **J11** (see section 2 fig 2.2)
- √ If an output range of 0 – 5 V or 1 – 5 V is required wires **V OUT** and **GND** should be connected on **J12** (see section 2 fig 2.2)
- √ Using the user interface press & release the DOWN or UP KEY (**10 or 9**) repeatedly until the display (1) shows **OP** for output range selection
- √ To adjust the output press & release the SET/ZERO KEY (**8**)
- √ The present range is now shown (**r0 or r4**). Refer to table below to see which output range is selected with different combinations of connections.

Table 3.1 Output Range Selection Reference

Cable Connections	Range Selected	Output Range
I OUT and 24V	r0	0 – 20 mA
V OUT and GND	r0	0 – 5 V dc
I OUT and 24V	r4	4 – 20 mA
V OUT and GND	r4	1 – 5 V dc

4.1 Operating Instructions (Refer to Fig. 3.1)

- √ Switch on the power supply
- √ Allow 2 minutes for the instrument to warm up
- √ Flow oil-free water through the system for a few minutes. If the display is greater than zero, then a clean water calibration will need to be performed (**see section 3.4**)
- √ Switch the instrument sample supply valve from the clean water supply to the sampling point connection.

THE INSTRUMENT IS NOW READY FOR USE

- √ When the sample is flowing through the monitor the display will adjust to show the current oil content of the sample.
- √ If the oil concentration exceeds any of the alarm set points (PPM), the Alarm 1 or 2 indicators (**4 & 5**) will be illuminated and the corresponding alarm relay will operate as soon as the set delay time for each alarm has expired.
- √ If an error code is displayed on the screen. The fault relay and both alarm relays will be activated. *See Section 6.1 for troubleshooting* and error code translations.

5.1 Operator Maintenance (Refer to Fig.1.2)

At WEEKLY intervals:

- √ Check the zero with oil-free water flowing through the instrument and reset if necessary (**see section 3.4**)
- √ Flush the cell with oil-free water.
- √ Isolate the instrument from both sample and oil-free water supply
- √ Unscrew and remove the cell cap (5)
- √ Insert a bottlebrush into the cell using an upward and downward motion.
- √ Remove the bottle brush and replace the cap (5)
- √ Re-connect the oil free water supply and allow this to flow through the instrument for a few minutes
- √ Re-check the zero calibration again
- √ Re-connect the instrument to the separator sampling point

AT MONTHLY intervals:

- √ Check the color of the DESSICATOR window (7) to ensure it is blue, indicating correct moisture content of cell. Replace dessicator if color is either PINK or WHITE.
- √ Install new dessicator by unscrewing the old dessicator unit (7) and inserting a new one. **DO NOT OVERTIGHTEN DESSICATOR** – Finger tight is sufficient. Ensure the O-ring seats properly against the cell housing.

Table 6.1 Error code translation table

Error Code	Meaning
Or	PPM value out of range
SH	Excessive solids content
bC	Bad clean water cal see page 15 sect.5
E1	No scatter signal
E2	No transmission signal
E3	Scatter signal out of range
E4	Transmission signal out of range

6.1 Troubleshooting Guideline

◆ Error Or:

- Oil concentration is out of selected range
- Check the range wiring (See Section 3.5)
- Change the programmed range (See Section 3.5)

◆ Error SH:

- Excessive solids content
- Perform flush and cleaning (See Section 5.1)

◆ Error BC:

- Bad clean water cal
- Perform flush and cleaning (See Section 5.1)
- Perform Clean Water Calibration (See Section 3.4)

◆ Error E1:

- No Scatter Signal
- Receiver has faulted, attempt cleaning (See Section 5.1), if problem persists contact Waltron

◆ Error E2:

- No Transmission Signal
- Light emitter has faulted, power off /on to attempt reset, if error persists contact Waltron

◆ Error E3 and E4

- Scatter and Transmission signal out of range
- Component calibration required at manufacture, contact Waltron Service department for Return Authorization

7.1 Technical Specifications

Range:	0-99 ppm
Accuracy:	+/- 2 ppm
Concentration Indication:	2 x 7 segment LED
Alarm Operating Points:	1- 99 ppm (adjustable)
Alarm 1 Operating Delay:	0-20 sec (adjustable)
Alarm 2 Operating Delay:	10-240 sec (adjustable by multiples of 10)
Alarm Contact Rating:	8A @ 240V (inductive)
Alarm Relay Mode:	De-energized in Alarm State
Zero Oil/Fault Indication:	Alphanumeric code
Output Signal:	0–20mA, 4–20mA (820 Ω max load) , 0-5V & 1-5V DC (50 K Ω min load)
Projected Life (Electronics):	> 50,000 Hours
Ambient Temperature:	+1°C to +55°C
Humidity:	90% RH Max @ 55°C
Sample Temperature:	+1°C TO +40°C
Sample Flow:	0.1 to 2 Liter/Minute
Sample Pressure:	0.1 to 10 Bar
Clean Water Requirement:	As for sample
Weight:	2.25kg (5lbs.)
Size:	215x242x73mm (8.5 x 9.5 x2.9)
Supply Voltage:	2 models available 230v/115v ac & 24V ac
Supply Variation:	\pm 10% of Nom. Voltage
Supply Frequency:	50/60 Hz
Consumption:	10 VA Max Alarm
Degree of Protection:	IP 55
Electrical installation (over voltage) classification: EN61010-1EC664 category 11	

8.1 Auto Clean System (where Fitted) (Refer to Fig.8.1)

The Auto clean System adds another level of reliability to the 2410 Oil in Water through the automation of the cell cleaning process. The assembly is designed to clean the cell tube every 5 - 60 minutes (user selectable see section 8 sub section 8.3) to reduce the build up of scale and other deposits on the inside of the glass. .

The 2410 Oil in Water is mounted onto a stainless steel back plate (4). Two conduits provide passage for wiring between the monitor and the customer terminal enclosure (3). Wiring is also provided to connect the solenoid valve (2) to the terminal enclosure, which in turn is connected to the auto clean control relay (fault relay on stand-alone monitor). The solenoid valve controls the airflow to the auto clean cylinder (1), which drives a wiper up and down to clean the cell tube. The air inlet fitting is 1/8" BSPT and flow should be regulated between 4 and 6 bar.

It is important to note that all the existing wiring on the panel is essential to the operation of the auto clean system and that removal of any such connections will impair the operation of the monitor.

Figure 8.1: CW Auto Clean Construction Configuration

ITEM NO.	DESCRIPTION
1	AUTO CLEAN CYLINDER
2	SOLENOID VALVE
3	CUSTOMERS TERMINAL ENCLOSURE
4	MOUNTING PLATE

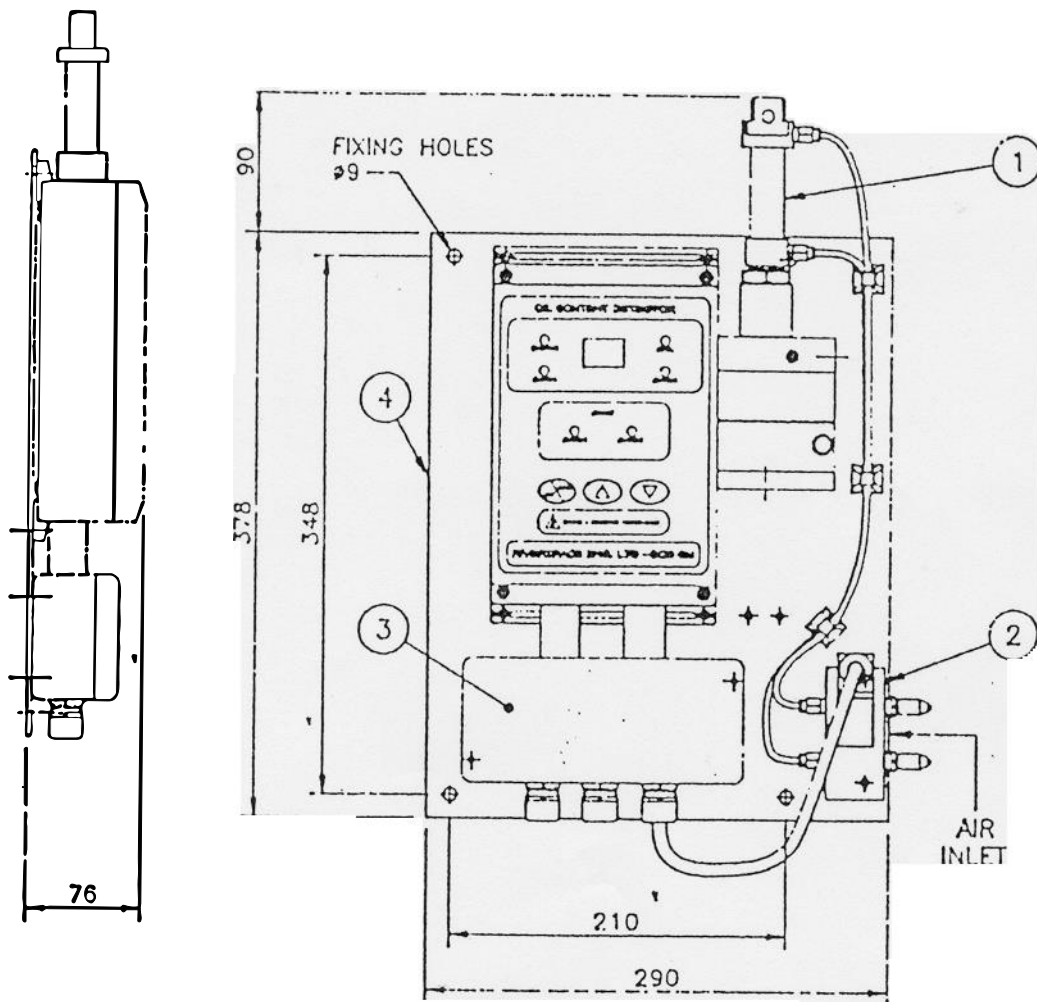

8.2 Auto Clean Terminal Enclosure (Refer to Fig 8.2)

Below is shown an expanded view of the customer terminal enclosure. Terminal identities match with those shown in section 2 (Fig. 2.2) except for the fault relay which is not available with the auto clean option.

Figure 8.2: 2410- Auto Clean Terminal Enclosure

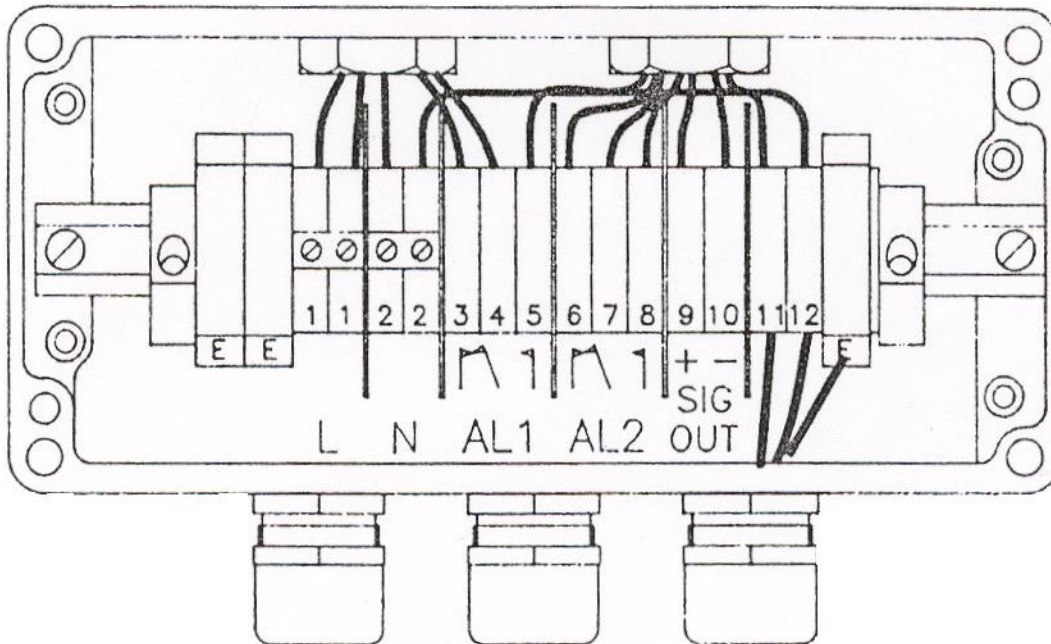

All remaining connections to the 2410 Oil in Water can be made as shown in Table 8.2

Table 8.2 Output Range Selection Reference

Cable Connections	RANGE SELECTED	OUTPUT RANGE
+ I OUT and - I OUT	r0	0-20 mA
+ V OUT and - V OUT	r0	0-5 V dc
+ I OUT and - I OUT	r4	4-20 mA
+ V OUT and - V OUT	r4	1-5 V dv

8.3 Auto Clean Cycle Frequency (where Fitted)

- Using the user interface Press & release the DOWN or UP KEY (**10 or 9**) repeatedly until the display shows **AC**.
- To view the current frequency Press & release the SET/ZERO KEY (**8**). The auto clean frequency is now shown in minutes on the display.
- Adjust the frequency by pressing the UP or DOWN KEY (**10 or 9**) until the desired value is displayed.
- Acknowledge the desired value by pressing and releasing the **SET/ZERO KEY (8)**.

9.1 Recommended Spare Parts:

Item	Qty.	Part Number
Dessicator	1	Q2410-6879
Bottle b rush	1	Q2410-0244
Fuse	1	Q2410-6989

Other Spare Parts:

Item	Qty.	Part Number
Cell assembly	1	Q2410-7661
Main PCB	1	Q2410-7053
Display PCB	1	Q2410-7037
Cable Gland	1	Q2410-6883
Manual Clean	1	Q2410-7229

For ordering information or to place an order call Waltron at 1-800-242-7353

Please have the following information ready:

Company Name:

Plant/Site:

Phone#:

Contact information:

Form of Payment CC/PO#:

Shipping/Billing Address:

Part#:

