

This operation guide describes installation, wiring, and other tasks required to make the controller ready for operation.

Contents

1. Safety Precautions
2. Model and Suffix Codes
3. How to Install
4. Hardware Specifications
5. How to Connect Wires
6. Terminal Wiring Diagrams

Introduction

Thank you for purchasing the UT35A-L Digital Indicating Controller. This operation guide describes the basic operations of the UT35A-L. The guide should be provided to the end user of this product. Be sure to read this operation guide before using the product in order to ensure correct operation. For details of each function, refer to the electronic manual. Before using the product, refer to the table of Model and Suffix Codes to make sure that the delivered product is consistent with the model and suffix codes you ordered. Also make sure that the following items are included in the package.

- Digital Indicating Controller (the model you ordered).....x1
- Set of Brackets.....x1
- Unit Label (L4502VZ).....x1
- Tag Label (L4502VE).....x1 (Only when ordered.)
- Operation Guide (this document).....x5 (A3 size) (Installation and Wiring, Initial Settings, Operations, and Parameters)

- Target Readers
This guide is intended for the following personnel;
 - Engineers responsible for installation, wiring, and maintenance of the equipment.
 - Personnel responsible for normal daily operation of the equipment.

1. Safety Precautions

The following symbol is used on the instrument. It indicates the possibility of injury to the user or damage to the instrument, and signifies that the user must refer to the user's manual for special instructions. The same symbol is used in the user's manual on pages that the user needs to refer to, together with the term "WARNING" or "CAUTION."

WARNING
Calls attention to actions or conditions that could cause serious or fatal injury to the user, and indicates precautions that should be taken to prevent such occurrences.

CAUTION
Calls attention to actions or conditions that could cause injury to the user or damage to the instrument or property and indicates precautions that should be taken to prevent such occurrences.

- AC**
- AC/DC**
- The equipment wholly protected by double insulation or reinforced insulation.
- Functional grounding terminals (Do not use this terminal as a protective grounding terminal).

Note

Identifies important information required to operate the instrument.

Warning and Disclaimer

- (1) YOKOGAWA makes no warranties regarding the product except those stated in the WARRANTY that is provided separately.
- (2) The product is provided on an "as is" basis. YOKOGAWA assumes no liability to any person or entity for any loss or damage, direct or indirect, arising from the use of the product or from any unpredictable defect of the product.

Safety, Protection, and Modification of the Product

- (1) In order to protect the system controlled by this product and the product itself, and to ensure safe operation, observe the safety precautions described in the user's manual. Use of the instrument in a manner not prescribed herein may compromise the product's functions and the protection features inherent in the device. We assume no liability for safety, or responsibility for the product's quality, performance or functionality should users fail to observe these instructions when operating the product.
- (2) Installation of protection and/or safety circuits with respect to a lightning protector; protective equipment for the system controlled by the product and the product itself; foolproof or fail-safe design of a process or line using the system controlled by the product or the product itself; and/or the design and installation of other protective and safety circuits are to be appropriately implemented as the customer deems necessary.
- (3) Be sure to use the spare parts approved by YOKOGAWA when replacing parts or consumables.
- (4) This product is not designed or manufactured to be used in critical applications that directly affect or threaten human lives. Such applications include nuclear power equipment, devices using radioactivity, railway facilities, aviation equipment, air navigation facilities, aviation facilities, and medical equipment. If so used, it is the user's responsibility to include in the system additional equipment and devices that ensure personnel safety.
- (5) Modification of the product is strictly prohibited.
- (6) This product is intended to be handled by skilled/trained personnel for electric devices.
- (7) This product is UL Recognized Component. In order to comply with UL standards, end-products are necessary to be designed by those who have knowledge of the requirements.

WARNING

- **Power Supply**
Ensure that the instrument's supply voltage matches the voltage of the power supply before turning ON the power.
- **Do Not Use in an Explosive Atmosphere**
Do not operate the instrument in locations with combustible or explosive gases or steam. Operation in such environments constitutes an extreme safety hazard. Use of the instrument in environments with high concentrations of corrosive gas (H₂S, SO_x, etc.) for extended periods of time may cause a failure.
- **Do Not Remove Internal Unit**
The internal unit should not be removed by anyone other than YOKOGAWA's service personnel. There are dangerous high voltage parts inside. Additionally, do not replace the fuse by yourself.
- **Damage to the Protective Construction**
Operation of the instrument in a manner not specified in the user's manual may damage its protective construction.

CAUTION
This instrument is an EMC class A product. In a domestic environment this product may cause radio interference in which case the user needs to take adequate measures.

2. Model and Suffix Codes

UT35A-L

[Style: S6]

Model	Suffix code	Optional suffix code	Description
UT35A			Digital Indicating Controller (provided with retransmission output, 2 DIs, and 3 DOs) (Power supply: 100-240 V AC)
Type 1: Basic control	-L		Limit control type
Type 2: Functions	0		Always "0"
	0		None
Type 3: Open networks	1		RS-485 communication (Max.38.4 kbps, 2-wire/4-wire)
	2		Ethernet communication (with serial gateway function)
Display language	-1		English
Case color	0		White (Light gray)
	1		Black (Light charcoal gray)
Fixed code		-00	Always "-00"
Optional suffix codes		/DC	Power supply 24 V AC/DC

Accessories (sold separately)

The following is an accessory sold separately.

- LL50A Parameter Setting Software

Model	Suffix code	Description
LL50A	-00	Parameter Setting Software

- Terminal Cover
Model: UTAP001
- User's Manual (A4 size)
Note: User's Manual can be downloaded from a website.
- User's Manual (CD-ROM), Model: UTAP003
Note: Contains all manuals.
- Brackets
Part number: L4502TP (2 pcs for upper and lower sides)

3. How to Install

Installation Location

The instrument should be installed in indoor locations meeting the following conditions:

- **Instrumented panel**
This instrument is designed to be mounted in an instrumented panel. Mount the instrument in a location where its terminals will not inadvertently be touched.
- **Well ventilated locations**
Mount the instrument in well ventilated locations to prevent the instrument's internal temperature from rising. However, make sure that the terminal portions are not exposed to wind. Exposure to wind may cause the temperature sensor accuracy to deteriorate. To mount multiple indicating controllers, see the external dimensions/panel cutout dimensions which follow. If mounting other instruments adjacent to the instrument, comply with these panel cutout dimensions to provide sufficient clearance between the instruments.
- **Locations with little mechanical vibration**
Install the instrument in a location subject to little mechanical vibration.
- **Horizontal location**
Mount the instrument horizontally and ensure that it is level, with no inclination to the right or left.

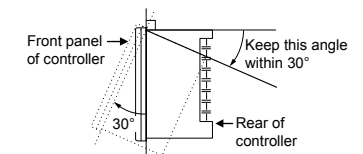

Note

If the instrument is moved from a location with low temperature and low humidity to a place with high temperature and high humidity, or if the temperature changes rapidly, condensation will result. Moreover, in the case of thermocouple inputs, measurement errors will result. To avoid such a situation, leave the instrument in the new environment under ambient conditions for more than 1 hour prior to using it.

Do not mount the instrument in the following locations:

- **Outdoors**
- **Locations subject to direct sunlight or close to a heater**
Install the instrument in a location with stable temperatures that remain close to an average temperature of 23°C. Do not mount it in locations subject to direct sunlight or close to a heater. Doing so adversely affects the instrument.
- **Locations with substantial amounts of oily fumes, steam, moisture, dust, or corrosive gases**
The presence of oily fumes, steam, moisture, dust, or corrosive gases adversely affects the instrument. Do not mount the instrument in locations subject to any of these substances.
- **Areas near electromagnetic field generating sources**
Do not place magnets or tools that generate magnetism near the instrument. If the instrument is used in locations close to a strong electromagnetic field generating source, the magnetic field may cause measurement errors.
- **Locations where the display is difficult to see**
The instrument uses an LCD for the display unit, and this can be difficult to see from extremely oblique angles. Mount the instrument in a location where it can be seen as much as possible from the front.
- **Areas close to flammable articles**
Absolutely do not place the instrument directly on flammable surfaces. If such a circumstance is unavoidable and the instrument must be placed close to a flammable item, provide a shield for it made of 1.43 mm thick plated steel or 1.6 mm thick unplated steel with a space of at least 150 mm between it and the instrument on the top, bottom, and sides.
- **Areas subject to being splashed with water**

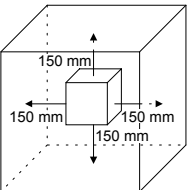

WARNING
Be sure to turn OFF the power supply to the controller before installing it on the panel to avoid an electric shock.

Waste Electrical and Electronic Equipment (WEEE), Directive 2002/96/EC

This is an explanation of how to dispose of this product based on Waste Electrical and Electronic Equipment (WEEE), Directive 2002/96/EC. This directive is only valid in the EU.

Marking

This product complies with the WEEE Directive (2002/96/EC) marking requirement. This marking indicates that you must not discard this electrical/electronic product in domestic household waste.



Indicates a manufacturing date in the black color part.

Product Category

With reference to the equipment types in the WEEE directive Annex 1, this product is classified as a "Monitoring and Control instrumentation" product. Do not dispose in domestic household waste. When disposing products in the EU, contact your local Yokogawa Europe B.V. office.

YOKOGAWA

YOKOGAWA ELECTRIC CORPORATION
Network Solutions Business Division
2-9-32, Naka-cho Musashino-shi, Tokyo 180-8750 JAPAN
YOKOGAWA CORPORATION OF AMERICA
Head office and for product sales
2 Dart Road, Newnan, Georgia 30265, USA
YOKOGAWA EUROPE B.V.
Headquarters
Euroweg 2, 3825 HD Amersfoort, THE NETHERLANDS
www.yokogawa.com/ns

■ Mounting the Instrument Main Unit

Provide an instrumented panel steel sheet of 1 to 10 mm thickness.
After opening the mounting hole on the panel, follow the procedures below to install the controller:

- 1) Insert the controller into the opening from the front of the panel so that the terminal board on the rear is at the far side.
- 2) Set the brackets in place on the top and bottom of the controller as shown in the figure below, then tighten the screws of the brackets. Take care not to overtighten them.

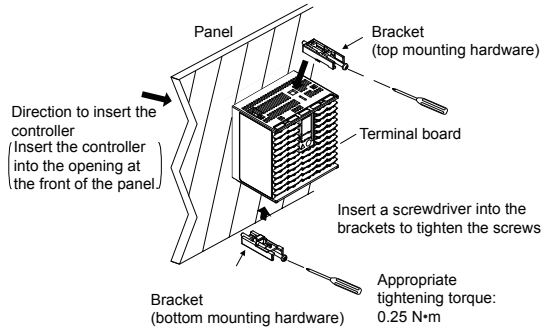

CAUTION

- Tighten the screws with appropriate tightening torque within 0.25 N·m. Otherwise it may cause the case deformation or the bracket damage.
- Make sure that foreign materials do not enter the inside of the instrument through the case's slit holes.

■ External Dimensions and Panel Cutout Dimensions

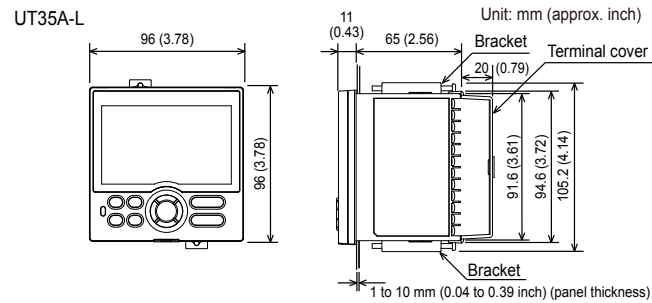

• General mounting

• Side-by-side close mounting

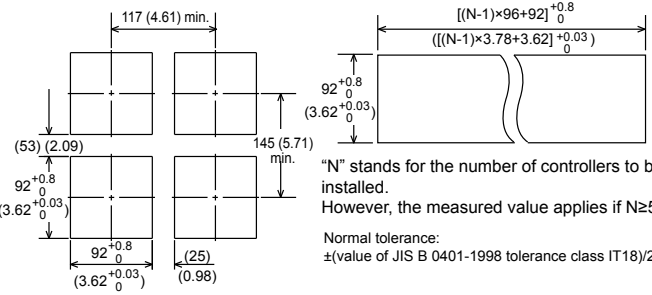

4. Hardware Specifications



WARNING

This instrument is for Measurement Category I (CAT.I). Do not use it for measurements in locations falling under Measurement Categories II, III, and IV.

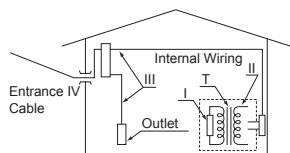

Category	Measurement category	Description	Remarks
I	CAT.I	For measurements performed on circuits not directly connected to MAINS.	-
II	CAT.II	For measurements performed on circuits directly connected to the low-voltage installation.	Appliances, portable equipment, etc.
III	CAT.III	For measurements performed in the building installation.	Distribution board, circuit breaker, etc.
IV	CAT.IV	For measurements performed at the source of the low-voltage installation.	Overhead wire, cable systems, etc.

■ Input Specifications

● Universal Input (Equipped as standard)

- Number of inputs: 1
- Input type, instrument range, and measurement accuracy: See the table below,

Input Type	Instrument Range		Accuracy	
	°C	°F		
Thermo-couple	K	-270.0 to 1370.0°C	-450.0 to 2500.0°F	±0.1% of instrument range ±1 digit for 0°C or more
		-270.0 to 1000.0°C	-450.0 to 2300.0°F	±0.2% of instrument range ±1 digit for less than 0°C
		-200.0 to 500.0°C	-200.0 to 1000.0°F	±2% of instrument range ±1 digit for less than -200.0°C of thermocouple K
	J	-200.0 to 1200.0°C	-300.0 to 2300.0°F	±1% of instrument range ±1 digit for less than -200.0°C of thermocouple J
		-270.0 to 400.0°C	-450.0 to 750.0°F	±1% of instrument range ±1 digit for less than -200.0°C of thermocouple J
	T	0.0 to 400.0°C	-200.0 to 750.0°F	±1% of instrument range ±1 digit for less than -200.0°C of thermocouple T
RTD	B	0.0 to 1800.0°C	32 to 3300°F	±0.15% of instrument range ±1 digit for 400°C or more
		±5% of instrument range ±1 digit for less than 400°C		
	S	0.0 to 1700.0°C	32 to 3100°F	±0.15% of instrument range ±1 digit
	R	0.0 to 1700.0°C	32 to 3100°F	±0.15% of instrument range ±1 digit
	N	-200.0 to 1300.0°C	-300.0 to 2400.0°F	±0.1% of instrument range ±1 digit for less than 0°C
		-270.0 to 1000.0°C	-450.0 to 1800.0°F	±0.1% of instrument range ±1 digit for 0°C or more
		-200.0 to 900.0°C	-300.0 to 1600.0°F	±0.2% of instrument range ±1 digit for less than 0°C
	L	-200.0 to 400.0°C	-300.0 to 750.0°F	±1.5% of instrument range ±1 digit for less than -200.0°C of thermocouple L
		0.0 to 400.0°C	-200.0 to 1000.0°F	±1.5% of instrument range ±1 digit for less than -200.0°C of thermocouple L
	U	0.0 to 400.0°C	-200.0 to 1000.0°F	±0.2% of instrument range ±1 digit (Note 2)
	W	0.0 to 2300.0°C	32 to 4200°F	±0.2% of instrument range ±1 digit (Note 2)
	Platinel 2	0.0 to 1390.0°C	32.0 to 2500.0°F	±0.1% of instrument range ±1 digit
PR20-40	0.0 to 1900.0°C	32 to 3400°F	±0.5% of instrument range ±1 digit for 800°C or more	
W97Re3-W75Re25	0.0 to 2000.0°C	32 to 3600°F	Accuracy is not guaranteed for less than 800°C.	
Standard signal	0.400 to 2.000 V		±0.1% of instrument range ±1 digit (Note 1)	
	1.000 to 5.000 V		±0.1% of instrument range ±1 digit (Note 1)	
	4.00 to 20.00 mA		±0.1% of instrument range ±1 digit (Note 1)	
	0.000 to 2.000 V		±0.1% of instrument range ±1 digit (Note 1)	
DC voltage/current	0.00 to 10.00 V		±0.1% of instrument range ±1 digit	
	0.00 to 20.00 mA			
	-10.00 to 20.00 mV			
	0.0 to 100.0 mV			

The accuracy is that in the standard operating conditions: 23±2°C, 55±10%RH, and power frequency at 50/60 Hz.

Note 1: ±0.3°C ±1 digit in the range between 0 and 100°C, ±0.5°C ±1 digit in the range between -100 and 200°C.

Note 2: W: W-5% Re/W-26% Re(Hoskins Mfg.Co.). ASTM E988

- Input sampling (control) period: 200 ms
- Burnout detection: Functions at TC, RTD, and standard signal. Upscale, downscale, and off can be specified. For standard signal, burnout is determined to have occurred if it is 0.1 V or 0.4 mA or less.
- Input bias current: 0.05 µA (for TC or RTD)
- Measured current (RTD): About 0.16 mA
- Input resistance: TC or mV input: 1 MΩ or more
V input: About 1 MΩ
mA input: About 250 Ω
- Allowable signal source resistance: TC or mV input: 250 Ω or less
Effects of signal source resistance: 0.1 µV/Ω or less
DC voltage input: 2 kΩ or less
Effects of signal source resistance: About 0.01%/100 Ω
- Allowable wiring resistance: RTD input: Max. 150 Ω/wire (The conductor resistance between the three wires shall be equal.)
Wiring resistance effect: ±0.1°C/10 Ω
- Allowable input voltage/current: TC, mV, mA and RTD input: ±10 V DC
V input: ±20 V DC
mA input: ±40 mA
- Noise rejection ratio: Normal mode: 40 dB or more (at 50/60 Hz)
Common mode: 120 dB or more (at 50/60 Hz)
For 100-240 V AC, the power frequency can be set manually. Automatic detection is also available.
For 24 V AC/DC, the power frequency can be set manually.
- Reference junction compensation error: ±1.0°C (15 to 35°C)
±1.5°C (-10 to 15°C and 35 to 50°C)
- Applicable standards: JIS/IEC/DIN (ITS-90) for TC and RTD

■ Step Response Time Specifications

Within 1 s (63% of analog output response time when a step change of 10 to 90% of input span is applied)

■ Relay Contact Output Specifications

- Contact type and number of outputs: Limit control output: contact point 1c; 1 point
Alarm output: contact point 1a; 3 points (common is independent)
- Contact rating: Contact point 1c (limit control output): 250 V AC, 3 A or 30 V DC, 3 A (resistance load)
Contact point 1a (alarm output): 240 V AC, 1 A or 30 V DC, 1 A (resistance load)
- Use: Alarm output, FAIL output, etc.
- Time resolution of limit control output: 10 ms or 0.1% of output, whichever is larger
Note: This cannot be used for a small load of 10 mA or less.

■ Retransmission Output Specifications

- Number of outputs: Retransmission output; 1
- Current output: 4 to 20 mA DC or 0 to 20 mA DC/ load resistance of 600 Ω or less
- Current output accuracy: ±0.1% of span (±5% of span for 1 mA or less)
The accuracy is that in the standard operating conditions: 23±2°C, 55±10%RH, and power frequency at 50/60 Hz.

■ Contact Input Specifications

- Number of inputs: 2 points
- Input type: No-voltage contact input or transistor contact input
- Input contact rating: 12 V DC, 10 mA or more
Use a contact with a minimum on-current of 1 mA or more.
- ON/OFF detection: No-voltage contact input: Contact resistance of 1 kΩ or less is determined as "ON" and contact resistance of 50 kΩ or more as "OFF."
Transistor contact input: Input voltage of 2 V or less is determined as "ON" and leakage current must not exceed 100 µA when "OFF."
- Minimum status detection hold time: Control period +50 ms
- Use: Confirmation operation, etc.

■ Safety and EMC Standards

- Safety: Compliant with IEC/EN61010-1 (CE), approved by CAN/CSA C22.2 No.61010-1 (CSA), approved by UL61010-1. Certified for FM-3810 and FM-3545.
Installation category: CAT. II Pollution degree: 2
Measurement category: I (CAT. I)
Rated measurement input voltage: Max. 10 V DC
Rated transient overvoltage: 1500 V (Note)

Note: This is a reference safety standard value for Measurement Category I of IEC/EN/CSA/UL61010-1. This value is not necessarily a guarantee of instrument performance.

• EMC Conformity standards:

- CE marking
EN61326-1 Class A, Table 2 (For use in industrial locations)
EN61326-2-3
EN 55011 Class A, Group1
EN 61000-3-2 Class A
EN 61000-3-3

C-tick mark

- EN 55011 Class A, Group1

The instrument continues to operate at a measurement accuracy of within ±20% of the range during testing.

■ Construction, Installation, and Wiring

- Degree of protection provided by Enclosure: IP66 (for front panel) (Not available for side-by-side close mounting.)
- Material: Polycarbonate (Flame retardancy: UL94V-0)
- Case color: White (Light Gray) or Black (Light charcoal gray)
- Weight: 0.5 kg or less
- External dimensions (mm): 96 (W) × 96 (H) × 65 (depth from the panel face) (Depth except the projection on the rear panel)
- Installation: Direct panel mounting; mounting bracket, one each for upper and lower mounting
- Panel cutout dimensions (mm): 92^{+0.80} (W) × 92^{+0.80} (H)
- Mounting attitude: Up to 30 degrees above the horizontal. No downward tilting allowed.
- Wiring: M3 screw terminal with square washer (for signal wiring and power wiring)

■ Power Supply Specifications and Isolation

- Power supply: Rated voltage: 100-240 V AC (+10%/-15%), 50/60 Hz
24 V AC/DC (+10%/-15%) (for /DC option)
- Power consumption: 18 VA (DC:9 VA, AC: 14 VA if /DC option is specified)
- Data backup: Nonvolatile memory
- Power holdup time: 20 ms (for 100 V AC drive)
- Withstanding voltage
Between primary terminals and secondary terminals: 2300 V AC for 1 minute
Between primary terminals: 1500 V AC for 1 minute
Between secondary terminals: 500 V AC for 1 minute
(Primary terminals: Power* and relay output terminals; Secondary terminals: Analog I/O signal terminals, contact input terminals, communication terminals and functional grounding terminals.)
*: Power terminals for 24V AC/DC models are the secondary terminals.
- Insulation resistance: Between power supply terminals and a grounding terminal 20 MΩ or more at 500 V DC
- Isolation specifications

PV (universal) input terminals	Internal circuits	Power supply
Retransmission (analog) output terminals		
Control relay (contact point c) output terminals		
Alarm-1 relay (contact point a) output terminals		
Alarm-2 relay (contact point a) output terminals		
Alarm-3 relay (contact point a) output terminals		
Contact input terminals RS-485 communication terminals		
Ethernet communication terminal		

The circuits divided by lines are insulated mutually.

■ Environmental Conditions

Normal Operating Conditions:

- Ambient temperature: -10 to 50°C (-10 to 40°C for side-by-side close mounting)
- Ambient humidity: 20 to 90% RH (no condensation allowed)
- Magnetic field: 400 A/m or less
- Continuous vibration at 5 to 9 Hz: Half amplitude of 1.5 mm or less, 1oct/min for 90 minutes each in the three axis directions
Continuous vibration at 9 to 150 Hz: 4.9 m/s² or less, 1oct/min for 90 minutes each in the three axis directions
- Short-period vibration: 14.7 m/s², 15 seconds or less
- Shock: 98 m/s² or less, 11 ms
- Altitude: 2000 m or less above sea level
- Warm-up time: 30 minutes or more after the power is turned on
- Startup time: Within 10 seconds

*: The LCD (a liquid crystal display) is used for a display portion of this product. The LCD has a characteristic that the display action becomes late at the low temperature. However, the control function is not affected.

Transportation and Storage Conditions:

- Temperature: -25 to 70°C
- Temperature change rate: 20°C/h or less
- Humidity: 5 to 95% RH (no condensation allowed)

Effects of Operating Conditions

- Effect of ambient temperature: Voltage or TC input: ±1 µV/°C or ±0.01% of F.S./°C, whichever is larger
Current input: ±0.01% of F.S./°C
RTD input: ±0.05°C/°C (ambient temperature) or less
Analog output: ±0.02% of F.S./°C or less
- Effect of power supply voltage fluctuation
Analog input: ±0.05% of F.S. or less
Analog output: ±0.05% of F.S. or less
(Each within rated voltage range)

5. How to Connect Wires



- Wiring work must be carried out by a person with basic electrical knowledge and practical experience.
- Be sure to turn OFF the power supply to the controller before wiring to avoid an electric shock. Use a tester or similar device to ensure that no power is being supplied to a cable to be connected.
- As a safety measure, always install a circuit breaker (an IEC 60947-compatible product, 5 A, 100 V or 220 V AC) in an easily accessible location near the instrument. Moreover, provide indication that the switch is a device for turning off the power to the instrument.
- Install the power cable keeping a distance of more than 1 cm from other signal wires.
- The power cable is required to meet the IEC standards concerned or the requirements of the area in which the instrument is being installed.
- Wiring should be installed to conform to NEC (National Electrical Code: ANSI/NFPA-70) or the wiring construction standards in countries or regions where wiring will be installed.
- For control relay output, alarm relay output, and power terminal connections, use heat-resistant cables.
- Since the insulation provided to each relay output terminal is functional insulation, provide Reinforced insulation to the external of the device as necessary. (Refer to the drawing below.)

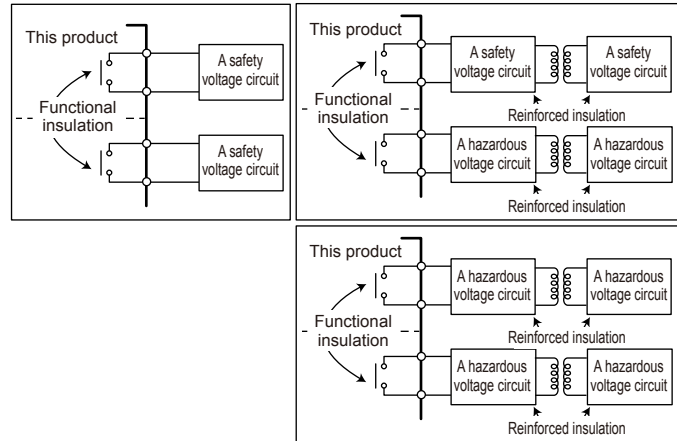

- When connecting two or more crimp-on terminal lugs to the single terminal block, bend the crimp-on terminal lugs before tightening the screw.
- Note that the wiring of two or more crimp-on terminal lugs to the single high-voltage terminal of the power supply and relay, etc. does not comply with the safety standard.



- Provide electricity from a single-phase power supply. If the power is noisy, install an isolation transformer on the primary side, and use a line filter on the secondary side. When measures against noise are taken, do not install the primary and secondary power cables close to each other.
- If there is a risk of external lightning surges, use a lightning arrester etc.
- For TC input, use shielded compensating lead wires for wiring. For RTD input, use shielded wires that have low conductor resistance and cause no significant differences in resistance between the three wires.
- Since the limit control output relay has a life span (resistance load of 100,000 times), use the auxiliary relay to perform ON/OFF control.
- The use of inductance (L) loads such as auxiliary relays, motors and solenoid valves causes malfunction or relay failure; always insert a CR filter for use with alternating current or a diode for use with direct current, as a spark-removal surge suppression circuit, into the line in parallel with the load.
- After completing the wiring, the terminal cover is recommended to use for the instrument.

Recommended Crimp-on Terminal Lugs

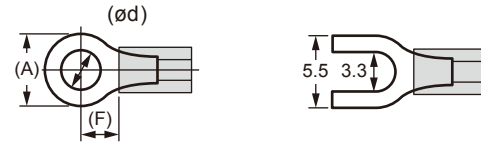

Recommended tightening torque: 0.6 N·m
Applicable wire size: Power supply wiring 1.25 mm² or more

Applicable terminal lug	Applicable wire size mm ² (AWG#)	(φ d)	(A)	(F)
M3	0.25 to 1.65 (22 to 16)	3.3	5.5	4.2

Cable Specifications and Recommended Cables

Purpose	Name and Manufacturer
Power supply, relay contact outputs	600 V Grade heat-resistant PVC insulated wires, JIS C 3317(HIV), 0.9 to 2.0 mm ²
Thermocouple	Shielded compensating lead wires, JIS C 1610
RTD	Shielded wires (three/four conductors), UL2482 (Hitachi Cable)
Other signals (other than contact input/output)	Shielded wires
Other signals (contact input/output)	Unshielded wires
RS-485 communication	Shielded wires
Ethernet communication	100 BASE-TX (CAT-5)/10 BASE-T

DC Relay Wiring

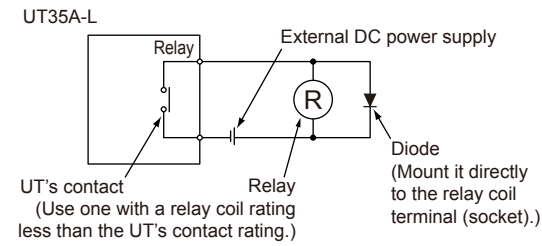

AC Relay Wiring

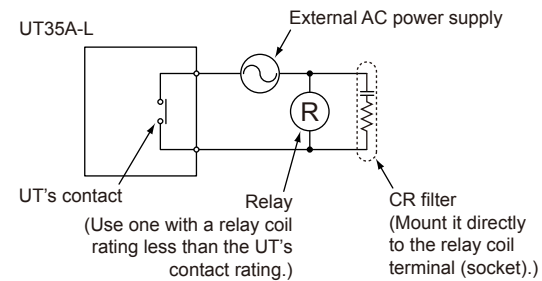

6. Terminal Wiring Diagrams



- Do not use an unassigned terminal as the relay terminal.
- Do not use a 100-240 V AC power supply for the 24 V AC/DC model; otherwise, the instrument will malfunction.

UT35A-L

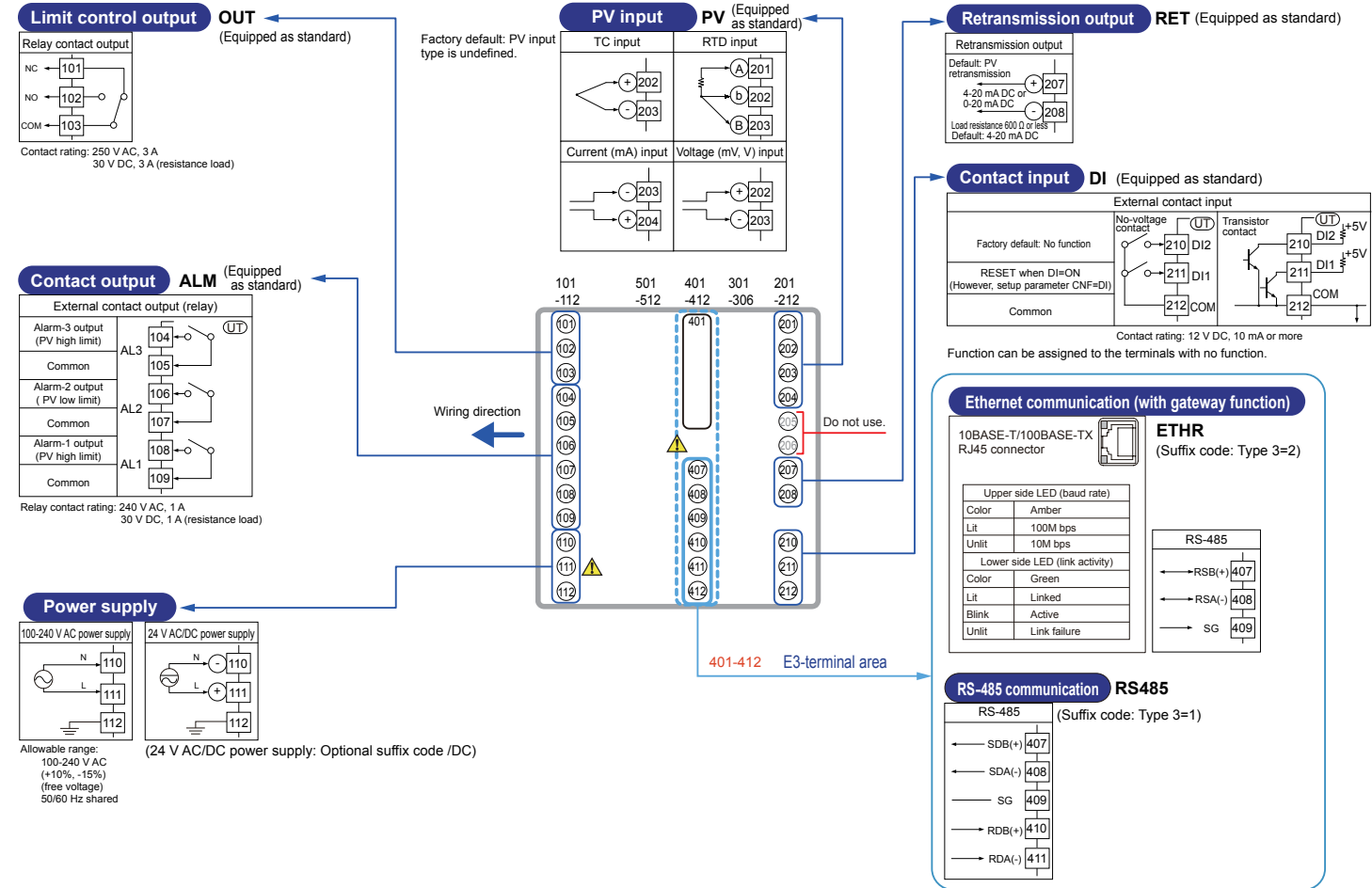

Intentionally blank

This operation guide describes basic settings and operations of the UT35A-L. For details of each function, see the electronic manual. The scrolling guide is displayed on PV display in the Parameter Setting Display. This guide can be turned on/off with the Fn key.

Contents

- Names and Functions of Display Parts
- Setup Procedure
- Quick Setting Function
- Setting Limit Control Type
- Setting Alarm Type
- Setting Alarm Setpoint

1. Names and Functions of Display Parts

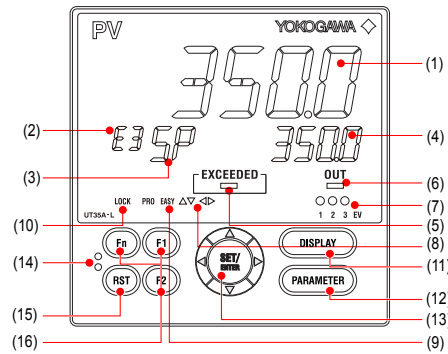

No. in figure	Name	Description												
(1)	PV display (white or red)	Displays PV. Displays an error code if an error occurs. Displays the scrolling guide in the Menu Display and Parameter Setting Display when the guide display ON/OFF is set to ON.												
(2)	Group display (green)	Displays terminal area (E3). E3 is displayed in the Parameter Setting Display.												
(3)	Symbol display (orange)	Displays a parameter symbol.												
(4)	Data display (orange)	Displays a parameter setpoint and menu symbol.												
(5)	EXCEEDED indicator (red)	Light to indicate the exceeded status of PV. Lights while PV exceeds SP.												
(6)	OUT indicator (orange)	Light to indicate the output status. Lights while the relay output is OFF.												
(7)	Event indicator (orange)	Lit when the alarms 1 to 3 occur. Event displays other than alarms can be set by the parameter.												
(8)	Key navigation indicator (green)	Lit or blinks when the Up/Down or Left/Right arrow key operation is possible.												
(9)	Parameter display level indicator (green)	Displays the setting conditions of the parameter display level function. <table border="1"> <thead> <tr> <th>Parameter display level</th> <th>EASY</th> <th>PRO</th> </tr> </thead> <tbody> <tr> <td>Easy setting mode</td> <td>Lit</td> <td>Unlit</td> </tr> <tr> <td>Standard setting mode</td> <td>Unlit</td> <td>Unlit</td> </tr> <tr> <td>Professional setting mode</td> <td>Unlit</td> <td>Lit</td> </tr> </tbody> </table>	Parameter display level	EASY	PRO	Easy setting mode	Lit	Unlit	Standard setting mode	Unlit	Unlit	Professional setting mode	Unlit	Lit
Parameter display level	EASY	PRO												
Easy setting mode	Lit	Unlit												
Standard setting mode	Unlit	Unlit												
Professional setting mode	Unlit	Lit												
(10)	Security indicator (red)	Lit if a password is set. The setup parameter settings are locked. Used to switch the Operation Displays.												
(11)	DISPLAY key	Press the key in the Operation Display to switch the provided Operation Displays. Press the key in the Menu Display or Parameter Setting Display to return to the Operation Display.												
(12)	PARAMETER key	Hold down the key for 3 seconds to move to the Operation Parameter Setting Display. Hold down the key and the Left arrow key simultaneously for 3 seconds to move to the Setup Parameter Setting Display. Press the key in the Parameter Setting Display to return to the Menu Display. Press the key once to cancel the parameter setting (setpoint is blinking).												
(13)	SET/ENTER key Up/Down/Left/Right arrow keys	SET/ENTER key Press the key in the Menu Display to move to the Parameter Setting Display of the Menu. Press the key in the Parameter Setting Display to transfer to the parameter setting mode (setpoint is blinking), and the parameter can be changed. Press the key during parameter setting mode to register the setpoint. Up/Down/Left/Right arrow keys Press the Left/Right arrow keys in the Menu Display to switch the Displays. Press the Up/Down/Left/Right arrow keys in the Parameter Setting Display to switch the Displays. Press the Up/Down arrow keys during parameter setting mode (setpoint is blinking) to change a setpoint. Press the Left/Right arrow keys during parameter setting mode (setpoint is blinking) to move between digits according to the parameter.												

(14)	Light-loader interface	It is the communication interface for the adapter cable used when setting and storing parameters from a PC. The LL50A Parameter Setting Software (sold separately) is required.
(15)	RST key	Used to confirm and reset the limit output and related parameters.
(16)	User function keys	The user can assign a function to the key. The function is set by the parameter.

Note: The communication connector (maintenance port) for LL50A Parameter Setting Software is on the top of the unit.

2. Setup Procedure

The following flowchart shows the setup procedure for UT35A-L.

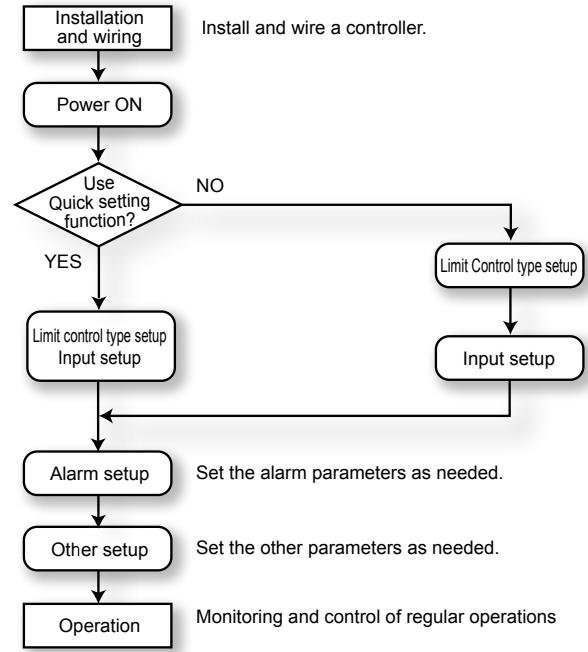

3. Quick Setting Function

The Quick setting function is a function to easily set the basic function of the controller. Turn on the controller to start the Quick setting function.

This function allows you to easily set the limit control type and input, and quickly start the control action.

The items (parameters) to be set by Quick setting function are as follows.

- Limit control type (High limit control or low limit control)
- Input function (PV input type, range, scale (at voltage input), etc.)

After turning on the controller, first decide whether or not to use the Quick setting function.

Operation in Initial Display

- Press the SET/ENTER key while YES is displayed to start the Quick setting function.
- If you change YES to NO and press the SET/ENTER key, Operation Display will appear without starting the Quick setting function.

Operation for Setting

- To select the parameter setting displayed as the initial value, press the Down arrow key to move to the next parameter.
- To change and set the parameter setting, press the SET/ENTER key to start the setpoint blinking. The blinking state allows you to make changes (setting mode). Use the Up/Down/Left/Right arrow keys to change the setpoint. Press the SET/ENTER key to register the setting.

Making Settings Using Quick Setting Function

Example: Setting to the low limit control type and the thermocouple type K (range of 0.0 to 500.0°F)

For the detailed procedure and switching of displays, see "Flow of Quick Setting Function" below. For the parameters to set, see the next column.

- Press the SET/ENTER key while YES for QSM (Quick setting mode) is displayed.
- Set the limit control type parameter (HI.LO) to LOW (Low limit control).
- Set the PV input type parameter (IN) to K1 (-450.0 to 2500.0 °F).
- Set the PV input unit parameter (UNIT) to F (Degree Fahrenheit).
- Set the maximum value of PV input range parameter (RH) to 500.0.
- Set the minimum value of PV input range parameter (RL) to 0.0.
- Finally, EXIT is displayed. Change NO to YES and press the SET/ENTER key to complete the setup. Operation Display appears.

Flow of Quick Setting Function

In Quick setting mode, the parameter guide appears on PV display. This guide can be turned on/off with the Fn key.

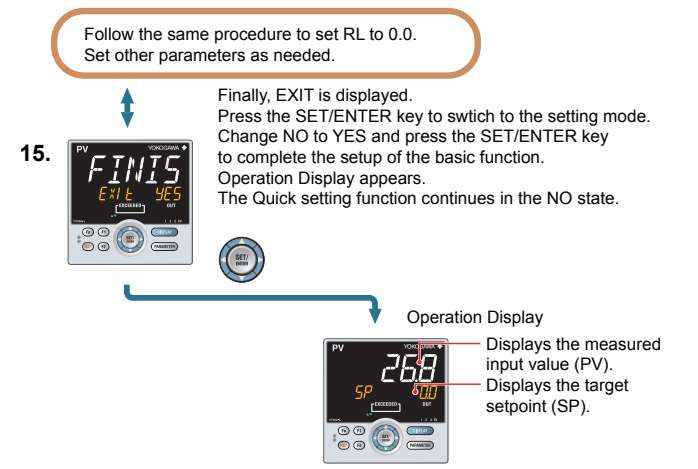
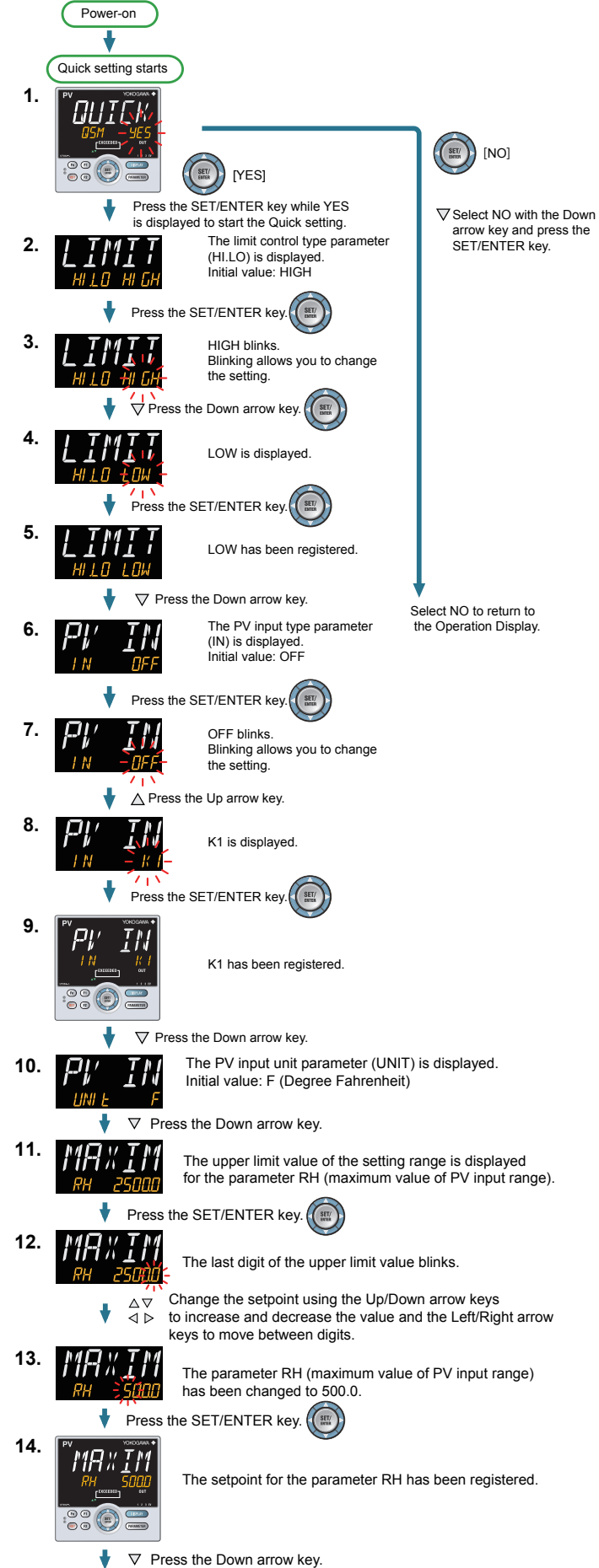

Parameters to be set

Limit Control Function

Parameter Symbol	Name of Parameter	Setting Range
HI.LO	Limit control type	LOW: Low limit control HIGH: High limit control

Input Function

Parameter Symbol	Name of Parameter	Setting Range
		OFF: Disable K1: -270.0 to 1370.0 °C / -450.0 to 2500.0 °F K2: -270.0 to 1000.0 °C / -450.0 to 2300.0 °F K3: -200.0 to 500.0 °C / -200.0 to 1000.0 °F J: -200.0 to 1200.0 °C / -300.0 to 2300.0 °F T1: -270.0 to 400.0 °C / -450.0 to 750.0 °F T2: 0.0 to 400.0 °C / -200.0 to 750.0 °F B: 0.0 to 1800.0 °C / 32 to 3300 °F S: 0.0 to 1700.0 °C / 32 to 3100 °F R: 0.0 to 1700.0 °C / 32 to 3100 °F N: -200.0 to 1300.0 °C / -300.0 to 2400.0 °F E: -270.0 to 1000.0 °C / -450.0 to 1800.0 °F L: -200.0 to 900.0 °C / -300.0 to 1600.0 °F U1: -200.0 to 400.0 °C / -300.0 to 750.0 °F U2: 0.0 to 400.0 °C / -200.0 to 1000.0 °F W: 0.0 to 2300.0 °C / 32 to 4200 °F PL2: 0.0 to 1390.0 °C / 32.0 to 2500.0 °F P2040: 0.0 to 1900.0 °C / 32 to 3400 °F WRE: 0.0 to 2000.0 °C / 32 to 3600 °F JPT1: -200.0 to 500.0 °C / -300.0 to 1000.0 °F JPT2: -150.0 to 150.0 °C / -200.0 to 300.0 °F PT1: -200.0 to 850.0 °C / -300.0 to 1560.0 °F PT2: -200.0 to 500.0 °C / -300.0 to 1000.0 °F PT3: -150.0 to 150.0 °C / -200.0 to 300.0 °F 0.4-2V: 0.400 to 2.000 V 1-5V: 1.000 to 5.000 V 4-20: 4.00 to 20.00 mA 0-2V: 0.000 to 2.000 V 0-10V: 0.00 to 10.00 V 0-20: 0.00 to 20.00 mA -1020: -10.00 to 20.00 mV 0-100: 0.0 to 100.0 mV
IN	PV input type	
UNIT	PV input unit	-: No unit, C: Degree Celsius -: No unit, -: No unit, --: No unit, F: Degree Fahrenheit
RH	Maximum value of PV input range	Depends on the input type. - For temperature input - Set the temperature range that is actually controlled. (RL<RH) - For voltage / current input - Set the range of a voltage / current signal that is applied. The scale across which the voltage / current signal is actually controlled should be set using the maximum value of input scale (SH) and minimum value of input scale (SL). (Input is always 0% when RL = RH.)
RL	Minimum value of PV input range	
SDP	PV input scale decimal point position	0: No decimal place 1: One decimal place 2: Two decimal places 3: Three decimal places 4: Four decimal places
SH	Maximum value of PV input scale	
SL	Minimum value of PV input scale	-19999 to 30000, (SL<SH), SH - SL ≤ 30000

Note 1: SDP, SH, and SL are displayed only for voltage/current input.
 Note 2: W: W-5%Re/W-26%Re (Hoskins Mfg.Co.), ASTM E988

4. Setting Limit Control Type

The following operating procedure describes an example of changing limit control type (factory-set default: high limit type) to low limit type.

1. Show the Operation Display.
2. Hold down the keys for 3 seconds.
 - * When a password is set, PASS is displayed. If the correct password is not entered, setup parameters cannot be changed.
 CTL menu is displayed.
3. Press the SET/ENTER key.
 - The parameter HI.LO (limit control type) is displayed.
4. Press the SET/ENTER key.
 - HIGH blinks.
5. Press the Down arrow key.
 - LOW is displayed. Blinks during the change.
6. Press the SET/ENTER key.
 - The setpoint has been registered. After the adjustment is completed, press the DISPLAY key once to return to the Operation Display.

5. Setting Alarm Type

The following operating procedure shows an example of changing the alarm-1 type (factory default: PV high limit alarm) to PV low limit alarm (setpoint: 02).

1. Show the Operation Display.
2. Hold down the key for 3 seconds.
 - SP menu is displayed.
3. Press the Right arrow key until ALRM menu appears.
 - ALRM menu is displayed.
4. Press the SET/ENTER key.
 - The parameter AL1 (alarm-1 type) is displayed.
5. Press the SET/ENTER key.
 - The last digit of the setpoint blinks.
6. Change the setpoint using the Up/Down arrow keys to increase and decrease the value and the Left/Right arrow keys to move between digits.
 - Press the SET/ENTER key.
 - The alarm-1 type setpoint 02 (PV low limit) is registered. After the setup is completed, press the DISPLAY key or DISP key once to return to the Operation Display.

- To change the alarm type, change the last 2 digits of the 5-digit value.
- Stand-by action and excitation are turned on or off by selecting 1 or 0. (See "Setting Display of Alarm Type.")
- For the latch action, see User's Manual.

Alarm Type (Alarm Setpoint)	Alarm Action (Energized)	Alarm Action (De-energized)
No alarm (00)	-	-
PV high limit (01)	Hysteresis Open (unit) Closed (lit) pv Alarm setpoint	Hysteresis Closed (unit) Open (lit) pv Alarm setpoint
PV low limit (02)	Hysteresis Closed (lit) Open (unit) Alarm setpoint pv	Hysteresis Open (unit) Closed (unit) Alarm setpoint pv
Deviation high limit (05)	Hysteresis Open (unit) Closed (lit) SP or Target SP	Hysteresis Closed (unit) Open (lit) SP or Target SP
Deviation low limit (06)	Hysteresis Closed (lit) Open (unit) Deviation setpoint PV ⊖ SP or Target SP	Hysteresis Open (unit) Closed (lit) Deviation setpoint PV ⊖ SP or Target SP
Deviation high and low limits (07)	Hysteresis Hysteresis Closed (lit) Open (unit) Closed (lit) Deviation setpoint PV SP or Target SP	Hysteresis Hysteresis Open (lit) Closed (unit) Open (lit) Deviation setpoint PV SP or Target SP
Deviation within high and low limits (08)	Hysteresis Hysteresis Open (unit) Closed (lit) Open (unit) Deviation setpoint PV SP or Target SP	Hysteresis Hysteresis Closed (unit) Open (lit) Closed (unit) Deviation setpoint PV SP or Target SP
PV velocity (29)		
Fault diagnosis alarm (30)		
FAIL (31)		

Note 1: "Open/closed" shows status of relay contact, and "lit/unlit" shows status of EV (event) lamp.
Note 2: ⊕ Positive setpoint, ⊖ Negative setpoint

Setting Display of Alarm Type

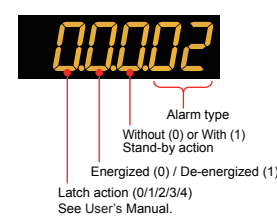

Stand-by Action

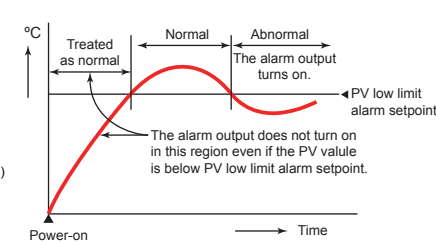

6. Setting Alarm Setpoint

The following operating procedure shows an example of setting the alarm-1 setpoint of group 1 to 180.0.

Before setting the alarm setpoint, check the alarm type. To change the alarm type, see "5. Setting Alarm Type."

1. Show the Operation Display.
2. Hold down the key for 3 seconds.
 - SP menu is displayed.
3. Press the SET/ENTER key.
 - Press the Down arrow key until A1 appears.
 - The parameter A1 is displayed. A1 to A3 represent the alarm-1 to -3 setpoints.
4. Press the SET/ENTER key.
 - Blinks during the change.
5. Press the SET/ENTER key.
 - The setpoint has been registered. After the setup is completed, press the DISPLAY key once to return to the Operation Display.

This operation guide describes key entries for operating the UT35A-L. For operations using external contact inputs, see "DI" of "6. Terminal Wiring Diagrams" in "Installation and Wiring."
If you cannot remember how to carry out an operation during setting, press the DISPLAY key once. This brings you to the display (Operation Display) that appears at power-on.
The scrolling guide is displayed on PV display in the Parameter Setting Display. This guide can be turned on/off with the Fn key.

Contents

1. Monitoring-purpose Operation Displays Available during Operation
2. Setting Target Setpoint (SP)
3. Confirmation of the Limit Output
4. Operation in Confirmation Display
5. Troubleshooting
6. Description of Limit Control Functions
7. Parameters in the Confirmation Displays
8. Function Block Diagram

1. Monitoring-purpose Operation Displays Available during Operation

Operation Display Switching Diagram

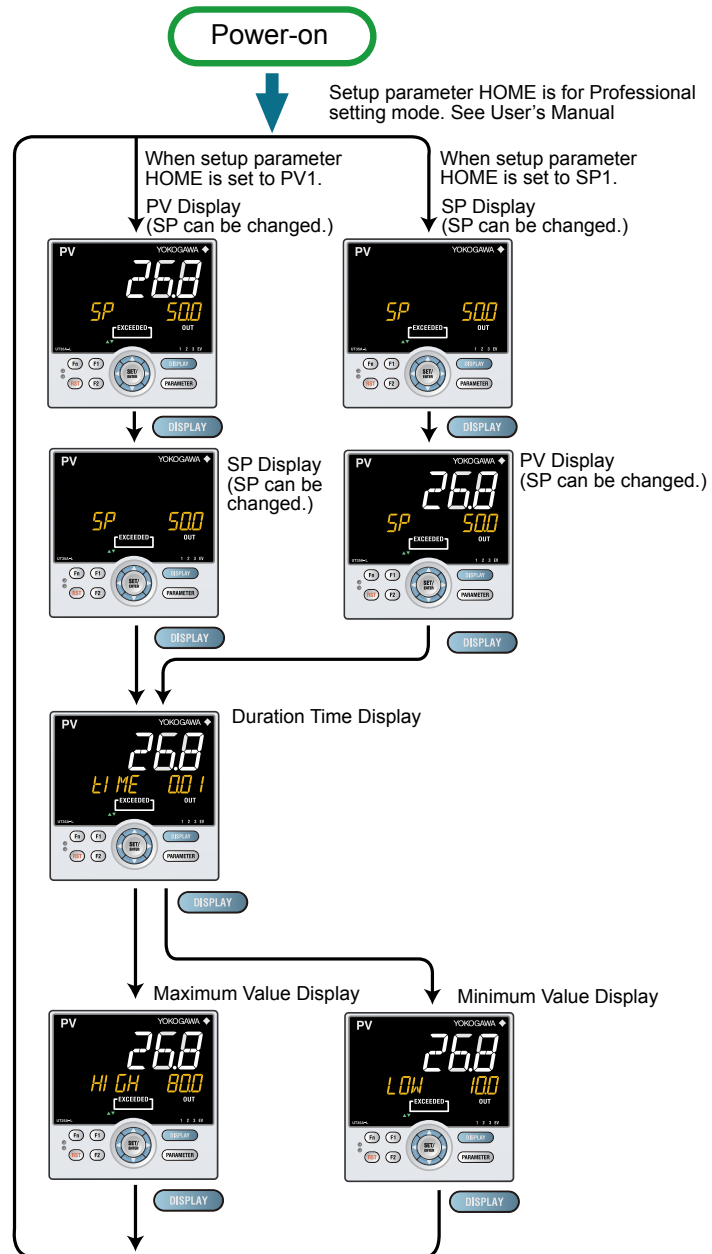

2. Setting Target Setpoint (SP)

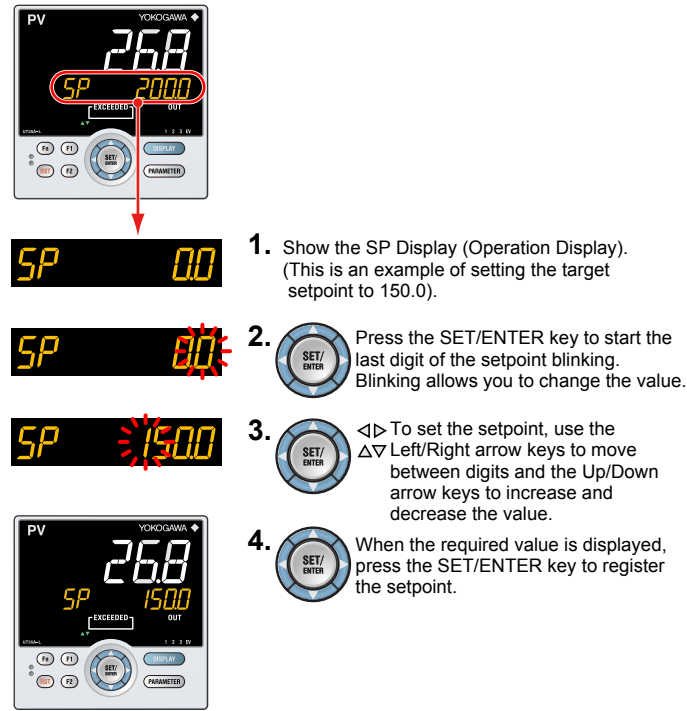

3. Confirmation of the Limit Output

When PV exceeds the setpoint for limit control (SP),
Procedure 1) The exceeded lamp lights, and also the output lamp lights.
Procedure 2) Exceeded lamp is off when the PV recovers to the normal status where PV doesn't exceed SP, while OUT lamp keeps lit until the confirmation is done.
Procedure 3) Confirmation of the limit output can be done either by a front panel or external contact input.
Here explains the way to reset key operation.

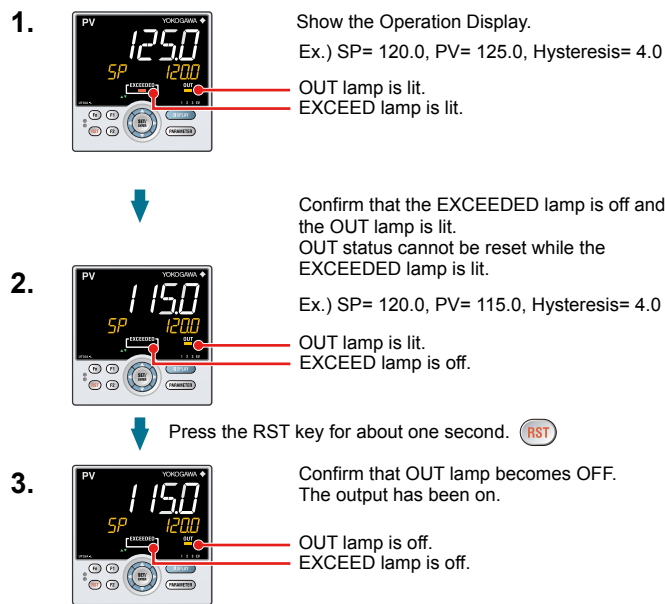

Confirmation of Limit Status

Limit control output and related parameter such as duration time and maximum / minimum PV value can be confirmed by a front key operation. It is possible to confirm limit control output by using external contact input. The way of confirmation is set by setup parameter CNF. Table below shows the item which can be confirmed by front key or external contact input according to the setting of CNF.

Item to be confirmed	CNF parameter = KEY		CNF parameter = DI	
	KEY	DI	KEY	DI
Output relay	Enable	Disable	Disable	Enable
Duration time	Enable	Disable	Enable	Disable
Maximum / Minimum value	Enable	Disable	Enable	Disable

4. Operation in Confirmation Display

Following parameters can be seen in the confirmation display. These parameters can be confirmed and reset by pressing the "RST" key at each parameter display.

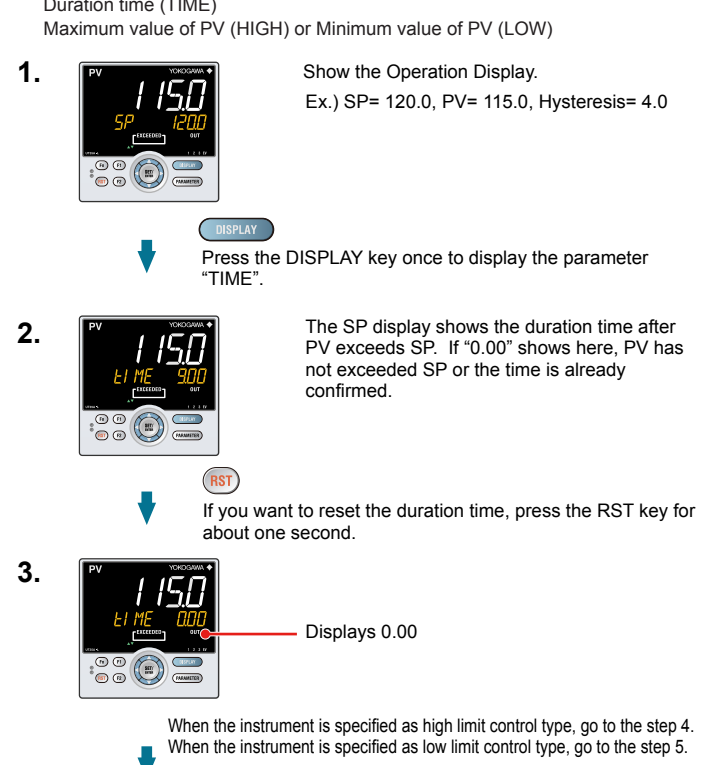

5. Troubleshooting

Troubleshooting Flow

If the Operation Display does not appear after turning on the controller's power, check the procedures in the following flowchart. If a problem appears to be complicated, contact our sales representatives.

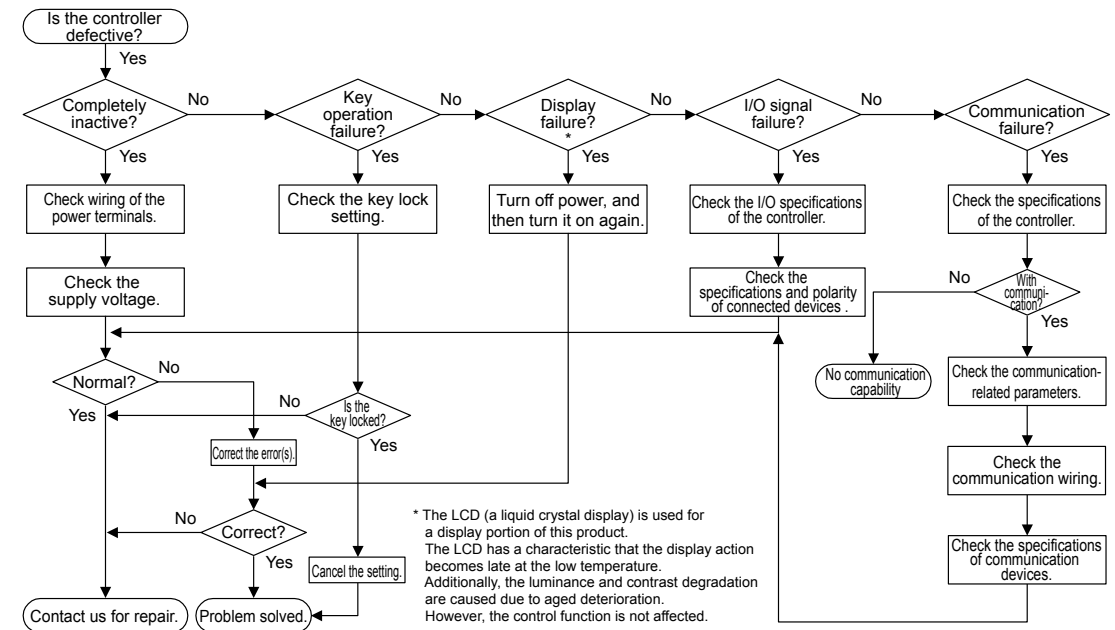

Remedies if Power Failure Occurs during Operations

- Instantaneous power failure within 20 ms. A power failure is not detected. Normal operation continues.
- Power failure for less than about 5 seconds, or for about 5 seconds or more. Affects the "settings" and "operation status." For details, see User's Manual.

NOTE

Write down the settings of parameters for a repair request.

■ Errors at Power On

The errors shown below may occur in the fault diagnosis when the power is turned on. (For details of Setpoint display and input/output action when each error occurs, see User's Manual.)

PV display (Operation Display)	Setpoint display (Operation Display)	Status indicator (Operation Display)	Parameter that displays error details	Error description	Cause and diagnosis	Remedy
Indication off	Indication off	—	—	Faulty MCU RAM / MCU ROM	MCU RAM / MCU ROM are failed.	Faulty. Contact us for repair.
ERR	SYS - - - -	—	—	System data error	System data is corrupted.	Faulty. Contact us for repair.
	PAR 0004 (for user default value error only)			User (parameter) default value error	User parameter is corrupted. Initialized to factory default value.	Check and reconfigure the initialized setting parameters. Error indication is erased when the power is turned on again.
	PAR 0010 (for setup parameter error only)			Setup parameter error	Setup parameter data is corrupted. Initialized to user default value.	
	PAR 0020 (for operation parameter error only)			Operation parameter error	Operation parameter data is corrupted. Initialized to user default value.	
SLOT 0004 (0004: Error occurs to hardware of E3-terminal areas.)	Setup parameter (OP.ER)	Nonresponding hardware of extended function (E3-terminal areas). Nonresponding communication between hardware of extended function (E3-terminal areas).	Faulty. Contact us for repair.			
Normal indication	Normal indication	Rightmost decimal point on PV display blinks.	Setup parameter (PA.ER)	Calibration value error	Initialized to calibrated default value because of corrupted factory default value.	Faulty. Contact us for repair.
		Rightmost decimal point on Symbol display blinks.	—	Faulty FRAM	Data writing (storing) to FRAM is impossible.	Faulty. Contact us for repair.

■ Errors during Operation

The errors shown below may occur during operation. (For input/output action when each error occurs, see User's Manual.)

PV display (Operation Display)	Setpoint display (Operation Display)	Status indicator (Operation Display)	Parameter that displays error details	Error description	Cause and diagnosis	Remedy
AD.ERR	Normal indication (Note)	—	Setup parameter (AD1.E)	Analog input terminal ADC error +PV input	Analog input terminal AD value error	Faulty. Contact us for repair.
RJC.E (Displays RJC. E and PV alternately.)	Normal indication (Note)	—	Setup parameter (AD1.E)	Universal input terminal RJC error +PV input	Universal input terminal RJC error	Faulty. Contact us for repair. Set the parameter RJC to OFF to erase error indication.
B.OUT	Normal indication (Note)	—	Setup parameter (AD1.E)	Analog input terminal burnout error +PV input	Analog input terminal sensor burnout	Check wiring and sensor. Error indication is erased in normal operation.
			Setup parameter (PV1.E)	PV input burnout error	Burnout of analog input connected to PV	Check wiring and sensor of connected analog input terminals. Error indication is erased in normal operation.
OVER- OVER	Normal indication	—	Setup parameter (PV1.E)	PV input over-scale PV input under-scale (PV values out of -5 to 105%)	PV input is out of -5 to 105%. Also occurs when the data out of range which is the ladder calculation result is input.	Check analog input value or ladder program.
Normal indication	0.000 00000 (Decimal point on the left of the Symbol display blinks)	—	Setup parameter (OP.ER)	Framing parity error Buffer overflow Inter-character time-out Checksum error (PC link communication with checksum) CRC check error (Modbus/RTU) LRC check error (Modbus/ASCII)	Communication error (RS-485 communication)	Check the communication parameters. Recovery at normal receipt. Hold down any key to stop blinking.
Normal indication	Normal indication	Rightmost decimal point on Symbol display blinks.	Setup parameter (PA.ER)	Faulty FRAM	Writing (storing) data to FRAM is impossible.	Faulty. Contact us for repair.
Undefined	Undefined	—	—	Faulty MCU / DCU (ROM / RAM error, corrupted)	MCU / DCU is corrupted.	Faulty. Contact us for repair.

6. Description of Limit Control Functions

■ In Case of High Limit Control

When PV exceeds a setpoint (SP), "EXCEEDED" lamp lights, and "OUT" lamp turns ON (point A). The limit control output relay is de-energized then.

"EXCEEDED" lamp turns off when PV goes into normal condition, while "OUT" lamp stays on as it is (point B). "OUT" lamp turns off when a confirming operation is done by an operator (point C). The way to confirm is pushing the "RST" key (or by an external contact, according to the setting of setup parameter CNF). The confirming operation is not accepted during PV exceeds SP (point D). State of output relay is de-energized whenever "OUT" lamp is on. (NC terminal: CLOSE, NO terminal: OPEN)

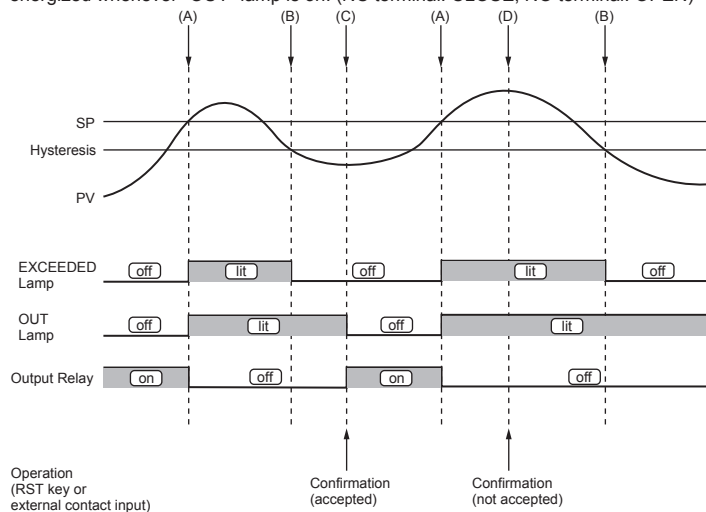

■ In Case of Low Limit Control

When PV exceeds a setpoint (SP), "EXCEEDED" lamp lights, and "OUT" lamp turns ON (point A). The limit control output relay is de-energized then.

"EXCEEDED" lamp turns off when PV goes into normal condition, while "OUT" lamp stays on as it is (point B). "OUT" lamp turns off when a confirming operation is done by an operator (point C). The way to confirm is pushing the "RST" key (or by an external contact, according to the setting of setup parameter CNF). The confirming operation is not accepted during PV exceeds SP (point D). State of output relay is de-energized whenever "OUT" lamp is on. (NC terminal: CLOSE, NO terminal: OPEN)

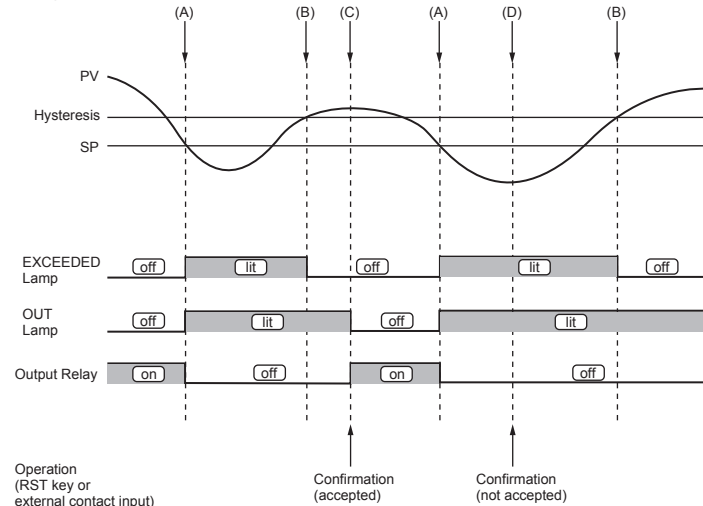

■ Power on Status

The state of output relay at power-on can be set by a setup parameter restart mode R.MD.

Restart mode R.MD:

- 0 : Limit output relay is de-energized at power on.
- 1 : Limit output relay is energized at power on.

■ When parameter R.MD is set to 0.

The limit output relay is always de-energized at power on, even if PV doesn't exceed SP (point A). (NC terminal: CLOSE, NO terminal: OPEN), "OUT" lamp is lit. After the confirmation, state of output relay is energized (NC terminal: OPEN, NO terminal: CLOSE) and "OUT" lamp turns off, if the PV doesn't exceed SP (point B).

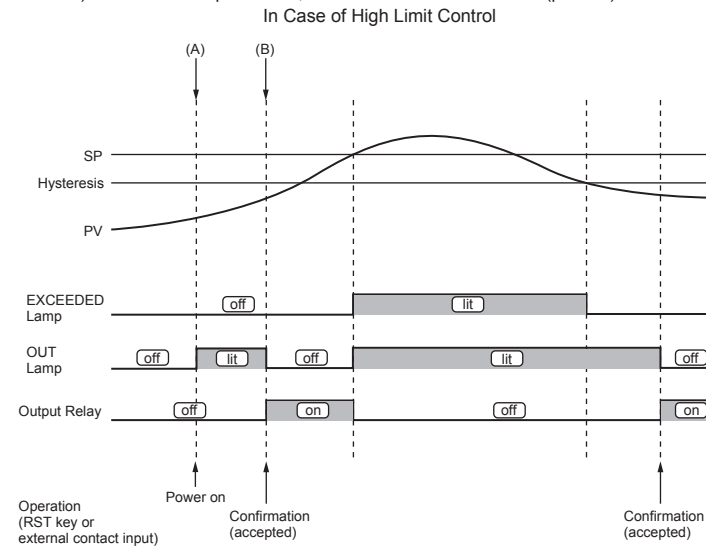

■ When parameter R.MD is set to 1.

The limit output relay is always energized at power on (point A) (NC terminal: OPEN, NO terminal: CLOSE) and "OUT" lamp is off, except when PV exceeds SP at power on.

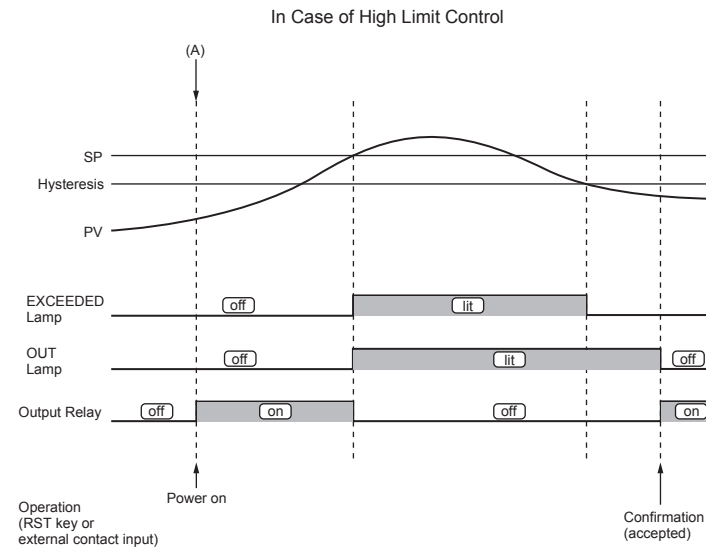

7. Parameters in the Confirmation Displays

■ Duration Time

The time while PV exceeds SP is counted and stored in the memory. It is displayed in the "TIME" display in the confirmation display.

Display time range : 0.00 to 99.59

Unit of time is be either "hour.minute" or "minute.second", and can be set by operation parameter TMU.

- To RESET
- Push "RST" key for about one second to reset the duration time in the confirmation display where "TIME" is displayed.
- When the count are reset, "0.00" is displayed until PV exceeds SP again.
- The time count are reset when power is turned on.
- If PV exceeds SP during the old time count data is retained in the memory, the old data should be automatically reset, and the new time counting starts from "0.00".
- It is impossible to reset the time count while PV exceeds SP by any operation.
- Duration time cannot be reset by an external contact input.

■ Maximum / Minimum Value

The maximum value or minimum value of PV is stored in the memory and display in the "HIGH" or "LOW" display in the confirmation display.

When the control type is specified as high limit control, the maximum value is displayed in the "HIGH" display, and control type is specified as low limit control, the maximum value is displayed in the "LOW" display.

When the PV exceeds SP and then returns to the normal status, Maximum / Minimum Value is retained as it is, but when PV exceeds SP again, it is automatically reset and starts taking new value for its minimum / maximum value.

- To RESET

- Push the "RST" key for about one second to reset the maximum / minimum value in the confirmation display where "HIGH" or "LOW" is displayed. The value is reset, and the value immediately after the confirmation should be recognized as a maximum or minimum value.
- When the power is turn on, the memory should be reset and the first PV should be recognized as maximum.
- Maximum / Minimum value cannot be reset by an external contact input.
- It is impossible to reset the maximum / minimum value while PV exceeds SP by any operation.

8. Function Block Diagram

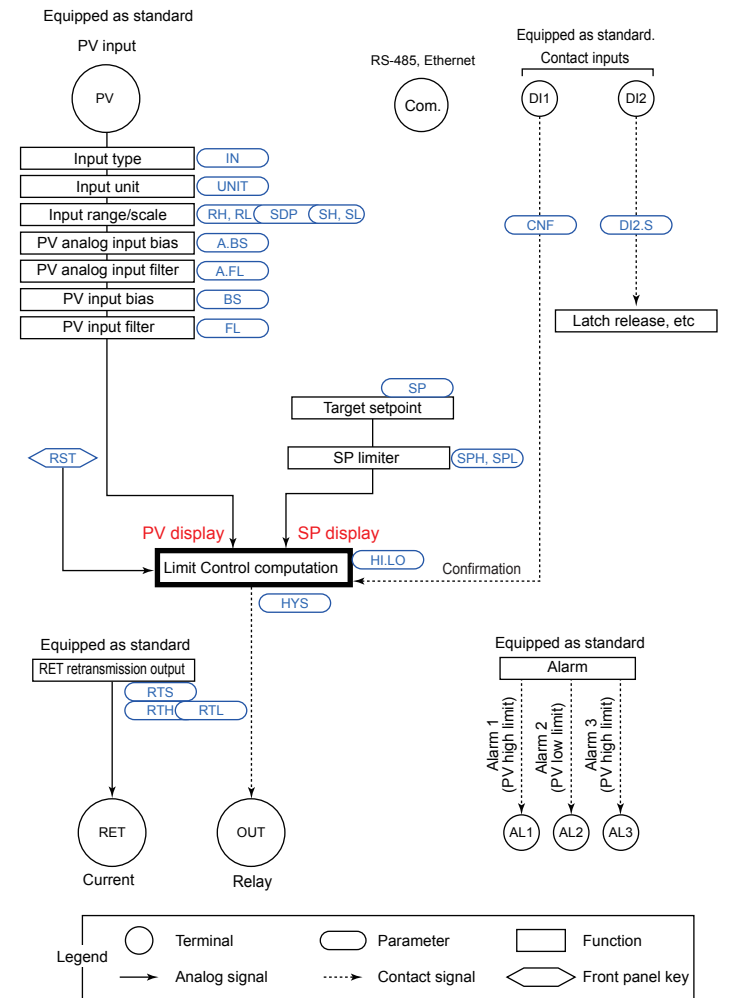

Parameters

This operation guide describes the functions of parameters briefly. The parameter symbols listed are in the order shown on the display in each group of menu symbols. In addition, each parameter table has a "User Setting" column, where you can record your setpoints when setting them in the controller. The scrolling guide is displayed on PV display in the Parameter Setting Display. This guide can be turned on/off with the Fn key.

Operation Parameters

Hold down the PARAMETER key for 3 seconds to move from the Operation Display to the Operation Parameter Setting Display. Press the DISPLAY key once to return to the Operation Display.

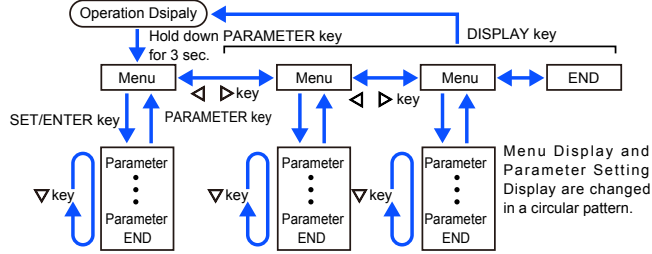

Move to the Setup Parameter Setting Display:
Hold down the PARAMETER key and the Left arrow key simultaneously for 3 sec.

Operation for Setting

- To select the parameter setting displayed as the initial value, press the Down arrow key to move to the next parameter.
- To change and set the parameter setting, press the SET/ENTER key to start the setpoint blinking. The blinking state allows you to make changes (setting mode). Use the Up/Down/Left/Right arrow keys to change the setpoint. Press the SET/ENTER key to register the setting.

Note that there are some parameters which are not displayed depending on the suffix codes. The parameters for professional setting mode (LEVL: PRO) are not described in this manual. See User's Manual.

SP and Alarm Setpoint Setting Parameter

Menu symbol: **SP** (SP)

Parameter symbol	Name of Parameter	Setting Range	Initial value	User setting	Display level
SP (SP)	Target setpoint	0.0 to 100.0% of PV input range (EU) (Setting range: SPL to SPH)	SPH		
A1 (A1)	Alarm-1 setpoint	Set a display value of setpoint of PV alarm, deviation alarm, or velocity alarm. -19999 to 30000 (Set a value within the input range.) Decimal point position depends on the input type	0		EASY
A2 (A2)	Alarm-2 setpoint		0		
A3 (A3)	Alarm-3 setpoint		0		

SP-related Setting Parameter

Menu symbol: **SPS** (SPS)

Parameter symbol	Name of Parameter	Setting Range	Initial value	User setting	Display level
TMU (TMU)	Time unit for duration time	HH.MM: Hour and minute MM.SS: Minute and second	HH.MM		EASY

Alarm Function Setting Parameter

Menu symbol: **ALRM** (ALRM)

Parameter symbol	Name of Parameter	Setting Range	Initial value	User setting	Display level
AL1 (AL1)	Alarm-1 to 3 type Example: Alarm-1 AL1 00001 Alarm type Latch action Energized/De-energize Stand-by action	Set a 5-digit value in the following order. [Alarm type: 2 digits (see below)] + [Without (0) or With (1) Stand-by action] + [Energized (0) or De-energized (1)] + [Latch action (0/1/2/3/4)] For latch action, see User's Manual.	AL1: PV high limit (01) Without Stand-by action (0) Energized (0) Latch action (0)		EASY
AL2 (AL2)			AL2: PV low limit (02) Without Stand-by action (0) Energized (0) Latch action (0)		
AL3 (AL3)			Alarm type: 2 digits 00: Disable 01: PV high limit 02: PV low limit 05: Deviation high limit 06: Deviation low limit 07: Deviation high and low limits 08: Deviation within high and low limits 29: PV velocity 30: Fault diagnosis 31: FAIL		
VT1 (VT1)	PV velocity alarm time setpoint 1	0.01 to 99.99 (minute.second)	1.00		EASY
VT2 (VT2)	PV velocity alarm time setpoint 2		1.00		
VT3 (VT3)	PV velocity alarm time setpoint 3		1.00		
HY1 (HY1)	Alarm-1 hysteresis	Set a display value of setpoint of hysteresis. -19999 to 30000 (Set a value within the input range.) Decimal point position depends on the input type. When the decimal point position for the input type is set to "1", the initial value of the hysteresis is "1.0".	10		EASY
HY2 (HY2)	Alarm-2 hysteresis		10		
HY3 (HY3)	Alarm-3 hysteresis		10		
DYN1 (DYN1)	Alarm-1 On-delay timer	An alarm output is ON when the delay timer expires after the alarm setpoint is reached. 0.00 to 99.99 (minute.second)	0.00		STD
DYN2 (DYN2)	Alarm-2 On-delay timer		0.00		
DYN3 (DYN3)	Alarm-3 On-delay timer		0.00		

PV-related Setting Parameter

Menu symbol: **PVS** (PVS)

Parameter symbol	Name of Parameter	Setting Range	Initial value	User setting	Display level
BS (BS)	PV input bias	-100.0 to 100.0% of PV input range span (EUS)	0.0 % of PV input range span		EASY
FL (FL)	PV input filter	OFF, 1 to 120 s	OFF		
HYS (HYS)	Limit control output hysteresis	0.0 to 100.0% of PV input range span (EUS)	0.5 % of PV input range span		

Setup Parameters

Hold down the PARAMETER key and Left arrow key simultaneously for 3 seconds to move from the Operation Display or Operation Parameter Setting Display to the Setup Parameter Setting Display. Press the DISPLAY key once to return to the Operation Display.

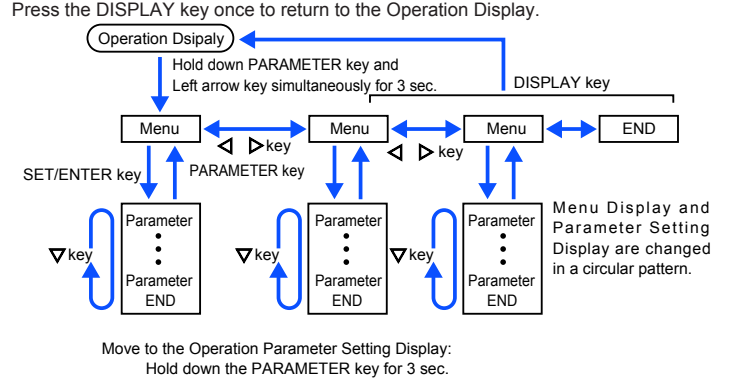

Operation for Setting

- To select the parameter setting displayed as the initial value, press the Down arrow key to move to the next parameter.
- To change and set the parameter setting, press the SET/ENTER key to start the setpoint blinking. The blinking state allows you to make changes (setting mode). Use the Up/Down/Left/Right arrow keys to change the setpoint. Press the SET/ENTER key to register the setting.

Note that there are some parameters which are not displayed depending on the Suffix codes. The parameters for professional setting mode (LEVL: PRO) are not described in this manual. See User's Manual.

Control Function Setting Parameter

Menu symbol: **CTL** (CTL)

Parameter symbol	Name of Parameter	Setting Range	Initial value	User setting	Display level
HILO (HILO)	Limit control type	LOW: Low limit control HIGH: High limit control	HIGH		EASY
CNF (CNF)	The way of confirming operation	KEY: By key operation DI: By DI	KEY		

PV Input Setting Parameter

Menu symbol: **PV** (PV)

Parameter symbol	Name of Parameter	Setting Range	Initial value	User setting	Display level
IN (IN)	PV input type	OFF: Disable K1: -270.0 to 1370.0 °C / -450.0 to 2500.0 °F K2: -270.0 to 1000.0 °C / -450.0 to 2300.0 °F K3: -200.0 to 500.0 °C / -200.0 to 1000.0 °F J: -200.0 to 1200.0 °C / -300.0 to 2300.0 °F T1: -270.0 to 400.0 °C / -450.0 to 750.0 °F T2: 0.0 to 400.0 °C / -200.0 to 750.0 °F B: 0.0 to 1800.0 °C / 32 to 3300 °F S: 0.0 to 1700.0 °C / 32 to 3100 °F R: 0.0 to 1700.0 °C / 32 to 3100 °F N: -200.0 to 1300.0 °C / -300.0 to 2400.0 °F E: -270.0 to 1000.0 °C / -450.0 to 1800.0 °F L: -200.0 to 900.0 °C / -300.0 to 1600.0 °F U1: -200.0 to 400.0 °C / -300.0 to 750.0 °F U2: 0.0 to 400.0 °C / -200.0 to 1000.0 °F W: 0.0 to 2300.0 °C / 32 to 4200 °F PL2: 0.0 to 1390.0 °C / 32.0 to 2500.0 °F P2040: 0.0 to 1900.0 °C / 32 to 3400 °F WRE: 0.0 to 2000.0 °C / 32 to 3600 °F JPT1: -200.0 to 500.0 °C / -300.0 to 1000.0 °F JPT2: -150.0 to 150.0 °C / -200.0 to 300.0 °F PT1: -200.0 to 850.0 °C / -300.0 to 1560.0 °F PT2: -200.0 to 500.0 °C / -300.0 to 1000.0 °F PT3: -150.0 to 150.0 °C / -200.0 to 300.0 °F 0.4-2V: 0.400 to 2.000 V 1-5V: 1.000 to 5.000 V 4-20: 4.00 to 20.00 mA 0-2V: 0.000 to 2.000 V 0-10V: 0.00 to 10.00 V 0-20: 0.00 to 20.00 mA -1020: -10.00 to 20.00 mV 0-100: 0.0 to 100.0 mV	OFF		EASY
UNIT (UNIT)	PV input unit	-: No unit, C: Degree Celsius -: No unit, -: No unit, ---: No unit, F: Degree Fahrenheit	F		
RH (RH)	Maximum value of PV input range	Depends on the input type. - For temperature input - Set the temperature range that is actually controlled. (RL<RH) - For voltage / current input - Set the range of a voltage / current signal that is applied.	Depends on the input type		
RL (RL)	Minimum value of PV input range	The scale across which the voltage/ current signal is actually controlled should be set using the maximum value of input scale (SH) and minimum value of input scale (SL). (Input is always 0% when RL = RH.)	Depends on the input type		
SDP (SDP)	PV input scale decimal point position	0: No decimal place 1: One decimal place 2: Two decimal places 3: Three decimal places 4: Four decimal places	Depends on the input type		
SH (SH)	Maximum value of PV input scale	-19999 to 30000, (SL<SH), SH - SL ≤ 30000	Depends on the input type		
SL (SL)	Minimum value of PV input scale		Depends on the input type		
BSL (BSL)	PV input burnout action	OFF: Disable UP: Upscale DOWN: Downscale	Depends on the input type		STD
ABS (ABS)	PV analog input bias	-100.0 to 100.0% of each input range span (EUS)	0.0 % of PV input range span		
AFL (AFL)	PV analog input filter	OFF, 1 to 120 s	OFF		

W: W-5% Re/W-26% Re(Hoskins Mfg.Co.). ASTM E988, WRE: W97Re3-W75Re25

Input Range, SP Limiter Setting Parameter

Menu symbol: *MPV* (MPV)

Parameter symbol	Name of Parameter	Setting Range	Initial value	User setting	Display level
<i>PUNI</i> (PUNI)	Control PV input unit	-: No unit C: Degree Celsius -: No unit --: No unit ---: No unit F: Degree Fahrenheit	Same as PV input unit		
<i>PdP</i> (PDP)	Control PV input decimal point position	0: No decimal place 1: One decimal place 2: Two decimal places 3: Three decimal places 4: Four decimal places	1		
<i>PRH</i> (PRH)	Maximum value of control PV input range	-19999 to 30000, (P.RL<P.RH), P.RH - P.RL ≤ 30000	Depends on the input type		STD
<i>PRL</i> (PRL)	Minimum value of control PV input range		Depends on the input type		
<i>SPH</i> (SPH)	SP high limit	0.0 to 100.0% of PV input range (EU), (SPL<SPH)	100.0 % of PV input range		
<i>SPL</i> (SPL)	SP low limit		0.0 % of PV input range		

Output Setting Parameter

Menu symbol: *OUT* (OUT)

Parameter symbol	Name of Parameter	Setting Range	Initial value	User setting	Display level
<i>RTS</i> (RTS)	Retransmission output type of RET	OFF: Disable PV1: PV SP1: SP	PV1		EASY
<i>RTH</i> (RTH)	Maximum value of retransmission output scale of RET	When RTS = PV1 or SP1, RTL + 1 digit to 30000 -19999 to RTH - 1 digit Decimal point position: When RTS=PV1 or SP1, decimal point position is same as that of PV input.	100 % of PV input range		STD
<i>RLL</i> (RTL)	Minimum value of retransmission output scale of RET		0 % of PV input range		
<i>RETA</i> (RETA)	RET current output range	4-20: 4 to 20 mA 0-20: 0 to 20 mA 20-4: 20 to 4 mA 20-0: 20 to 0 mA	4-20		

RS-485 Communication Setting Parameter (E3-terminal Area)

Menu symbol: *R485* (R485)

Parameter symbol	Name of Parameter	Setting Range	Initial value	User setting	Display level
<i>PSL</i> (PSL)	Protocol selection	PCL: PC link communication PCLSM: PC link communication (with checksum) LADR: Ladder communication MBASC: Modbus (ASCII) MBRTU: Modbus (RTU)	MBRTU		
<i>bPS</i> (BPS)	Baud rate	600: 600 bps 1200: 1200 bps 2400: 2400 bps 4800: 4800 bps 9600: 9600 bps 19200: 19.2k bps 38400: 38.4k bps	19200		EASY
<i>PRi</i> (PRi)	Parity	NONE: None EVEN: Even ODD: Odd	EVEN		
<i>STP</i> (STP)	Stop bit	1: 1 bit, 2: 2 bits	1		
<i>dLN</i> (DLN)	Data length	7: 7 bits, 8: 8 bits	8		
<i>ADR</i> (ADR)	Address	1 to 99	1		

Ethernet Communication Setting Parameter (E3-terminal Area)

Menu symbol: *ETHR* (ETHR)

Parameter symbol	Name of Parameter	Setting Range	Initial value	User setting	Display level
<i>HSR</i> (HSR)	High-speed response mode	OFF, 1 to 8	1		
<i>bPS</i> (BPS)	Baud rate	9600: 9600 bps 19200: 19.2k bps 38400: 38.4k bps	38400		
<i>PRi</i> (PRi)	Parity	NONE: None EVEN: Even ODD: Odd	EVEN		
<i>IP1</i> to <i>IP4</i> (IP1 to IP4)	IP address 1 to 4	0 to 255 Initial value: (IP1),(IP2),(IP3),(IP4) = (192),(168),(1),(1)	See left	Table below	
<i>SM1</i> to <i>SM4</i> (SM1 to SM4)	Subnet mask 1 to 4	0 to 255 Initial value: (SM1),(SM2),(SM3),(SM4) = (255),(255),(255),(0)	See left	Table below	
<i>dG1</i> to <i>dG4</i> (DG1 to DG4)	Default gateway 1 to 4	0 to 255 Initial value: (DG1),(DG2),(DG3),(DG4) = (0),(0),(0),(0)	See left	Table below	EASY
<i>PRT</i> (PRT)	Port number	502, 1024 to 65535	502		
<i>IPAR</i> (IPAR)	IP access restriction	OFF: Disable, ON: Enable	OFF		
<i>IP1</i> to <i>IP4</i> (IP1 to IP4)	Permitted IP address 1-1 to 1-4 Permitted IP address 2-1 to 2-4	0 to 255 Initial value: (1.IP1),(1.IP2),(1.IP3),(1.IP4) = (255),(255),(255),(255) (2.IP1),(2.IP2),(2.IP3),(2.IP4) = (255),(255),(255),(255)	See left	Table below	
<i>ESW</i> (ESW)	Ethernet setting switch	Setting this parameter to "ON" enables the Ethernet communication parameter settings. OFF, ON	OFF		

Use the following table to record Ethernet communication setting value.

Parameter	n=1	n=2	n=3	n=4
IPn				
SMn				
DGn				
1.IPn				
2.IPn				

Key Action Setting Parameter

Menu symbol: *KEY* (KEY)

Parameter symbol	Name of Parameter	Setting Range	Initial value	User setting	Display level
<i>F1</i> (F1)	User function key-1 action setting	OFF: Disable LTUP: LCD brightness UP LTDN: LCD brightness DOWN BRI: Adjust LCD brightness LCD: LCD backlight ON/OFF switch LAT: Latch release	OFF		EASY
<i>F2</i> (F2)	User function key-2 action setting		OFF		
<i>Fn</i> (Fn)	User function key-n action setting		OFF		

Display Function Setting Parameter

Menu symbol: *dSP* (DISP)

Parameter symbol	Name of Parameter	Setting Range	Initial value	User setting	Display level
<i>PCMD</i> (PCMD)	Active color PV display switch	0: Fixed in white 1: Fixed in red 2: Link to alarm 1 (Alarm OFF: white, Alarm ON: red) 3: Link to alarm 1 (Alarm OFF: red, Alarm ON: white) 4: Link to alarm 1 or 2 (Alarm OFF: white, Alarm ON: red) 5: Link to alarm 1 or 2 (Alarm OFF: red, Alarm ON: white) 6: PV limit (Within range: white, Out of range: red) 7: PV limit (Within range: red, Out of range: white) 8: SP deviation (Within deviation: white, Out of deviation: red) 9: SP deviation (Within deviation: red, Out of deviation: white) 10: Link to DI2 (ON: red, OFF: white) (*) 11: Link to EXCEEDED lamp (Unit: white, lit: red) 12: Link to OUT lamp (Unit: white, lit: red) *: Set the parameter DI2.S=PVRW	0		EASY
<i>PCH</i> (PCH)	PV color change high limit	Set a display value when in PV limit or SP deviation. -19999 to 30000 (Set a value within the input range.)	0		
<i>PCL</i> (PCL)	PV color change low limit	Decimal point position depends on the input type.	0		

<i>GUID</i> (GUID)	Guide display ON/OFF	OFF: Nondisplay, ON: Display	ON		
<i>EEO</i> (ECO)	Economy mode	OFF: Disable 1: Economy mode ON (All indications except PV display OFF) 2: Economy mode ON (All indications OFF) 3: Brightness 10 % (whole indication)	OFF		STD
<i>BRi</i> (BRi)	Brightness	(Dark) 1 to 5 (Bright)	3		EASY
<i>MLSD</i> (MLSD)	Least significant digital mask of PV display	OFF: With least significant digit ON: Without least significant digit	OFF		STD

Key Lock Setting Parameter

Menu symbol: *KLOC* (KLOC)

Parameter symbol	Name of Parameter	Setting Range	Initial value	User setting	Display level
<i>COMW</i> (COM.W)	Communication write enable/disable	OFF: Enable, ON: Disable	OFF		STD
<i>DLER</i> (DATA)	Front panel parameter data (▼,▲) key lock	OFF: Unlock, ON: Lock	OFF		

DI Function Registration Parameter

Menu symbol: *dSL* (DI.SL)

Parameter symbol	Name of Parameter	Setting Range	Initial value	User setting	Display level
<i>DI2S</i> (DI2.S)	DI2 function selection	OFF: No function LAT: Latch release LCD: LCD backlight ON/OFF switch PVRW: PV red/white switch (*) MG1: Message display interruption 1 MG2: Message display interruption 2 MG3: Message display interruption 3 MG4: Message display interruption 4 *: Set the parameter PCMD=10.	OFF		STD

System Setting Parameter

Menu symbol: *SYS* (SYS)

Parameter symbol	Name of Parameter	Setting Range	Initial value	User setting	Display level
<i>RMD</i> (R.MD)	Restart mode	0: Limit control output is ON at power on in any cases 1: Limit control output is OFF at power on when PV doesn't exceed SP	0		STD
<i>FREQ</i> (FREQ)	Power frequency	AUTO, 60: 60 Hz, 50: 50 Hz	AUTO		EASY
<i>QSM</i> (QSM)	Quick setting mode	OFF: Disable ON: Enable	ON		
<i>PASS</i> (PASS)	Password setting	0 (No password) to 65535	0		

Error and Version Confirmation Parameter (for display only)

Menu symbol: *VER* (VER)

Parameter symbol	Name of Parameter	Status record	Display level
<i>PAER</i> (PA.ER)	Parameter error status		
<i>OPER</i> (OP.ER)	Option error status		
<i>AD1E</i> (AD1.E)	A/D converter error status 1		
<i>PV1E</i> (PV1.E)	PV input error status		
<i>MCU</i> (MCU)	MCU version		
<i>dCU</i> (DCU)	DCU version		
<i>ECU3</i> (ECU3)	ECU-3 version (E3-terminal area)		EASY
<i>PARA</i> (PARA)	Parameter version		
<i>HVER</i> (H.VER)	Product version		
<i>SER1</i> (SER1)	Serial number 1		
<i>SER2</i> (SER2)	Serial number 2		
<i>MAC1</i> (MAC1)	MAC address 1 (E3-terminal area)		
<i>MAC2</i> (MAC2)	MAC address 2 (E3-terminal area)		
<i>MAC3</i> (MAC3)	MAC address 3 (E3-terminal area)		

Parameter Display Level Parameter

Menu symbol: *LVL* (LVL)

Parameter symbol	Name of Parameter	Setting Range	Initial value	User setting	Display level
<i>LEVL</i> (LEVL)	Parameter display level	EASY: Easy setting mode STD: Standard setting mode PRO: Professional setting mode	STD		EASY

* For Professional setting mode, see User's Manual.

Trademarks

- Our product names or brand names mentioned in this manual are the trademarks or registered trademarks of Yokogawa Electric Corporation.
- Adobe, Acrobat, and Postscript are either registered trademarks or trademarks of Adobe Systems Incorporated.
- Ethernet is a registered trademark of XEROX Corporation in the United States.
- Modbus is a registered trademark of Schneider Electric.
- We do not use the TM or ® mark to indicate these trademarks or registered trademarks in this manual.
- All other product names mentioned in this manual are trademarks or registered trademarks of their respective companies.