

UDC3500 Universal Digital Controller Printed Wiring Board Replacements Instruction 51-52-33-153

• **Kit contents** This kit contains one of the following replacement Printed Wiring Boards:

- UDC3500 MCU/Input Board – Part No. 51452828-502
 - UDC3500 Power 90-264 Vac Board – Part No. 51452831-501
 - UDC3500 Power 24 Vac/dc Board – Part No. 50006376-501
 - UDC3500 Display/Keyboard – Part No. 51452845-501
 - UDC3500 Dual Relay Board – Part No. 51452807-501
 - UDC3500 Optional Input Board – Part No. 51452825-501
 - UDC3500 Third Current Output Board – Part No. 51452834-501
 - UDC3500 Aux Out/Digital Inputs/RS-485 – Part No. 51452837-502
 - UDC3500 Digital Inputs/Ethernet Board – Part No. 51452840-501
 - UDC3500 Optional Relay Board – Part No. 51452843-501
-

Equipment needed

- Small flat-bladed screwdriver
- Small pliers

Procedures The procedure tables that follow list the steps required to replace the old Printed Wiring Board in your controller with the one supplied in this kit.

Continued on next page

Replacement Instruction, Continued

Chassis removal

Table 1 How to Remove the Chassis

Step	Action
1	Remove any screws in the front face.
2	Insert a flat-bladed screwdriver into the tabs of the case as shown in Figure 1 and pry chassis forward slightly until the chassis connectors separate from the back of the case.
3	Grasp the bezel and pull the chassis out of the case.

Figure 1 Chassis Removal

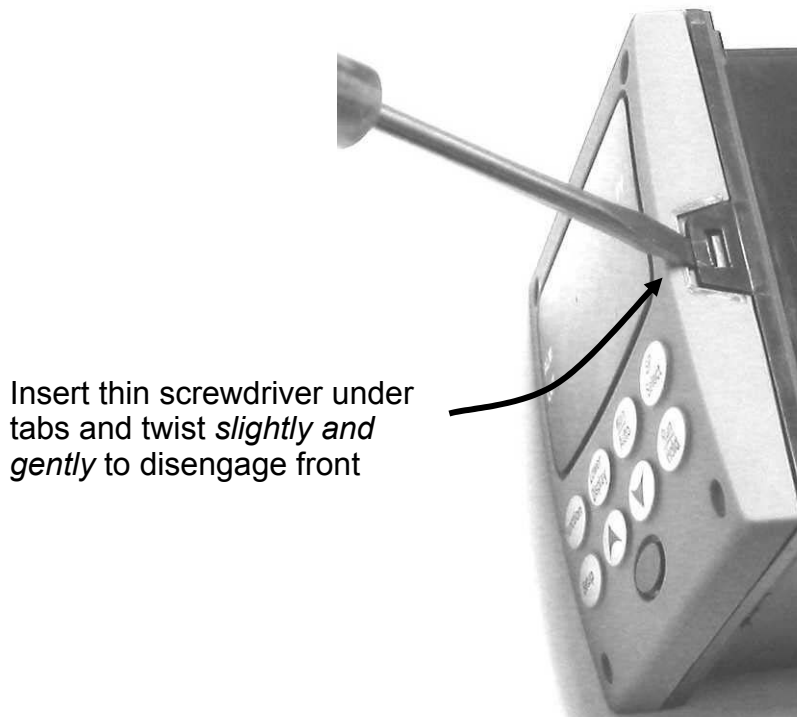

Using a thin screwdriver, gently twist the screwdriver to pry the side tabs from the front face. Pry just enough to release it, otherwise you'll bend or break the tab. If you break or bend the tab and can't reattach the front snugly, you'll need to reattach the front using the 4 NEMA4 screws provided.

Continued on next page

Replacement Instruction, Continued

Printed wiring board removal

Table 2 How to Remove the Printed Wiring Boards from the Chassis

Step	Action
1	Remove the chassis from the case as shown in Figure 1.
2	Separate the chassis frame at the release points shown in Figure 2 and wiggle each printed wiring board out of its socket on the display/keyboard assembly. Pull all boards out of the chassis.
3	Remove the wire connectors from plug WG1 on Power/Output Board. Slide a small screwdriver under the connectors and lift the release.
4	Lay the printed wiring boards flat on a static-free surface. Use Figures 3 through 6 to locate the board being replaced.

Figure 2 Removing the Printed Wiring Boards

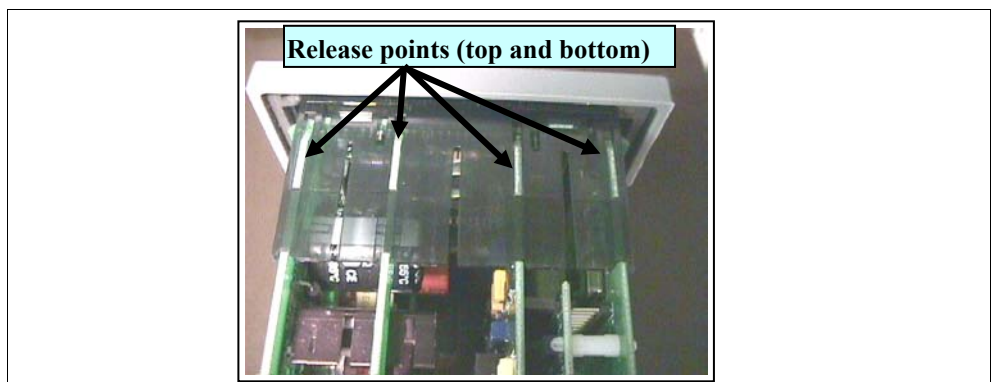

Printed wiring board identification

Figure 3 Major Printed Wiring Board Identification

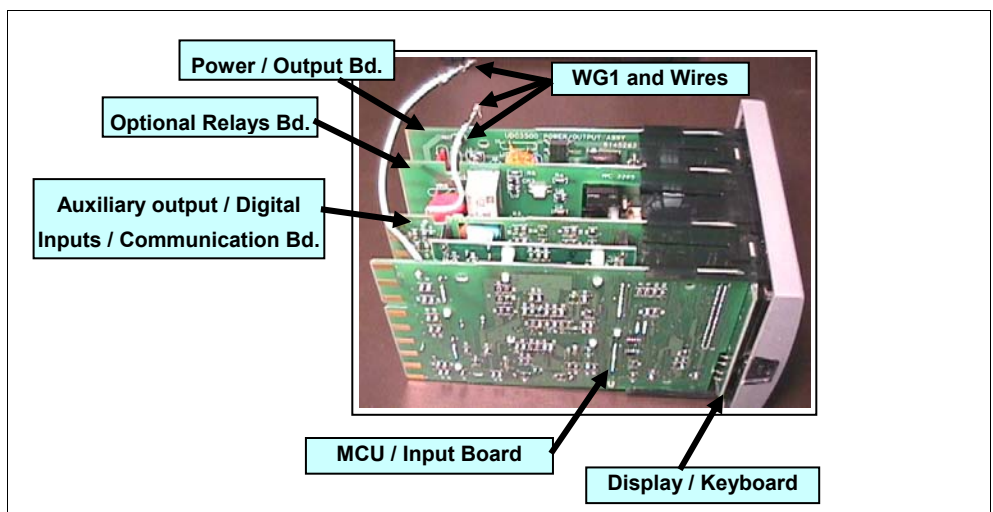

Continued on next page

Replacement Instruction, Continued

Printed wiring board identification

Figure 4 Optional Input Printed Wiring Board Identification

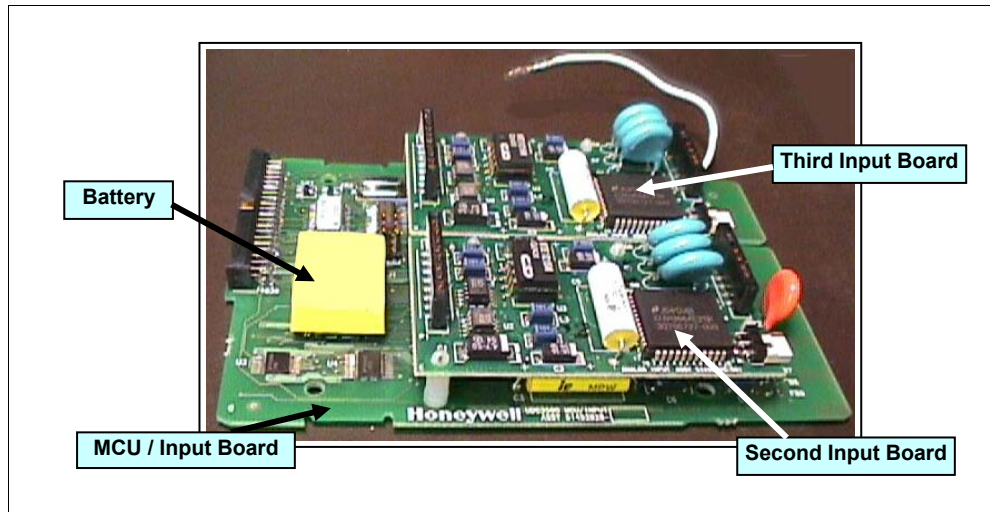

Printed wiring board identification

Figure 5 Third Current Output Printed Wiring Board Identification

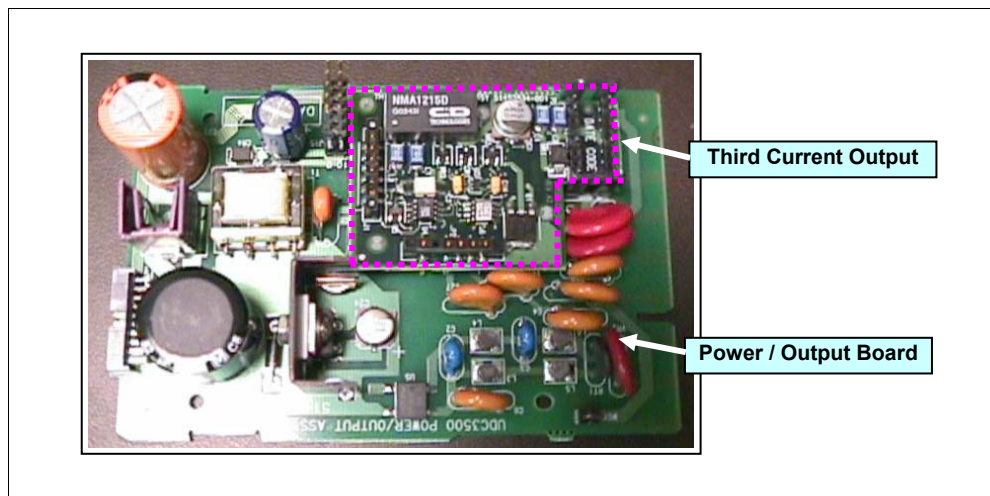

Printed wiring board identification

Figure 6 Dual Relay Printed Wiring Board Identification

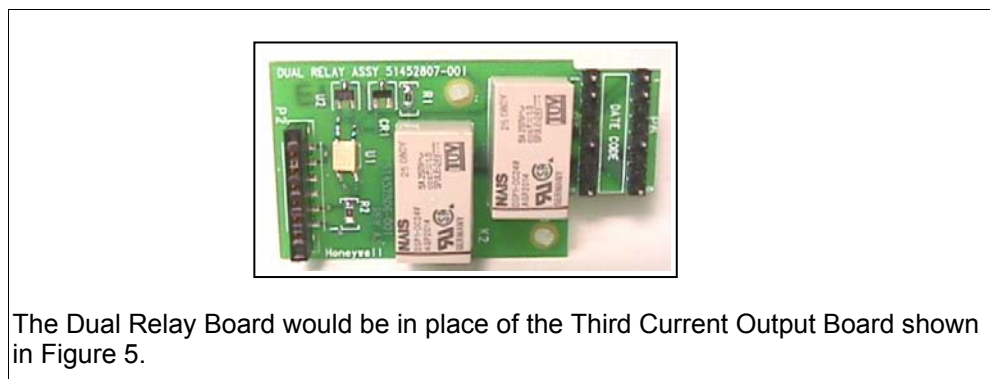

The Dual Relay Board would be in place of the Third Current Output Board shown in Figure 5.

Continued on next page

Replacement Instruction, Continued

Replacement procedure

Table 3 Board Replacement Procedure

Step	Action
1	Identify the Board to be replaced from Figures 3 through 6. Replace that board with the new one.
2	The small boards shown in Figures 4, 5 and 6 (Optional Input, Third Current Output and Dual Relay Output) are held onto the major boards with posts. If replacing one of these small boards or the major boards they are attached to, then locate the ends of the posts on the back side of the Major Board.
3	Use small pliers and squeeze the ends of each post together and push it up through the board.
4	Remove the small boards. Replace as needed. Posts must be pushed all the way through the Major Board until they snap into place in order to ensure a good electrical and mechanical connection.
5	The Third Current Output and Dual Relay Output boards must be fully seated into the socket in order to ensure a good electrical and mechanical connection.

Table 4 Chassis Reassembly Procedure

Step	Action
1	Install the Display/Keyboard into the chassis. There are four slots cut in the Bezel. Place the bottom of the Display/Keyboard into the slots and then press the top of the display in until it snaps in place in the slots. See Figure 7.
2	Assemble the Optional Relay board onto the Power/Output Board. Start these boards as a pair into the chassis groves and carefully push them in until they snap into place. See Figure 8.
3	Assemble the Communications board over the capacitors on the MCU/Input board. Start these boards as a pair into the chassis groves and carefully push them in until they snap into place. See Figure 9.
4	Make sure the connections to the display/keyboard assembly are made and that the release points on the chassis snap into place on the printed wiring boards. See Figure 10.
5	Reinstall the WG wires onto the Power/Output Board. See Figure 11.
6	Reinstall the chassis into the case.

Continued on next page

Replacement Instruction, Continued

Chassis Reassembly Figure 7 Display / Keyboard

There are four slots cut in the Bezel which fit four tabs on the Display / Keyboard. Place the bottom of the Display / Keyboard into the bottom chassis slots and press the top of the display in until it snaps into place in the top chassis slots.

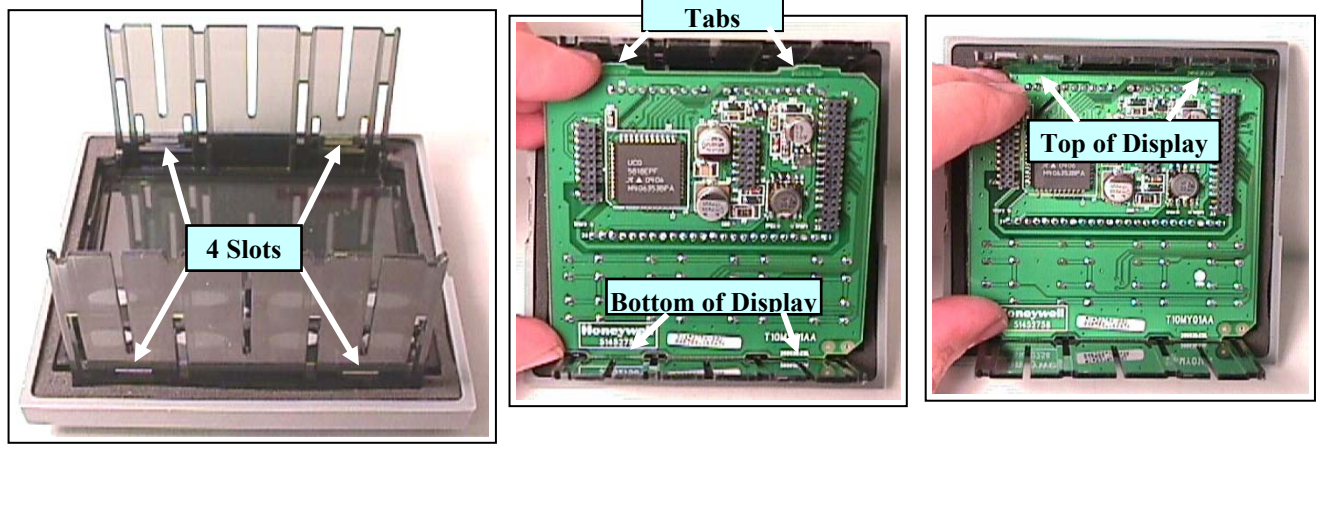

Chassis Reassembly Figure 8 Optional Relay and Power/Output Board

The P15 connector on the Optional Relay board plugs into J15 on the Power/Output board. Insert these boards as an assembly into the Chassis. Start them in the chassis grooves and carefully push them in until they snap into place.

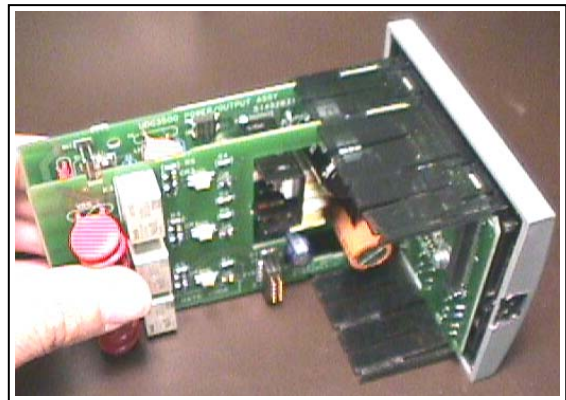
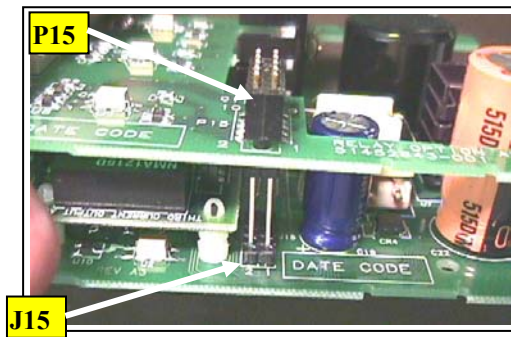

Continued on next page

Replacement Instruction, Continued

Chassis Reassembly Figure 9 Communications and MCU/Input Board

Place the Communications board over the Capacitors on the Optional Input Boards. Insert these boards as an assembly into the Chassis. Start them in the chassis groves and carefully push them in until they snap into place.

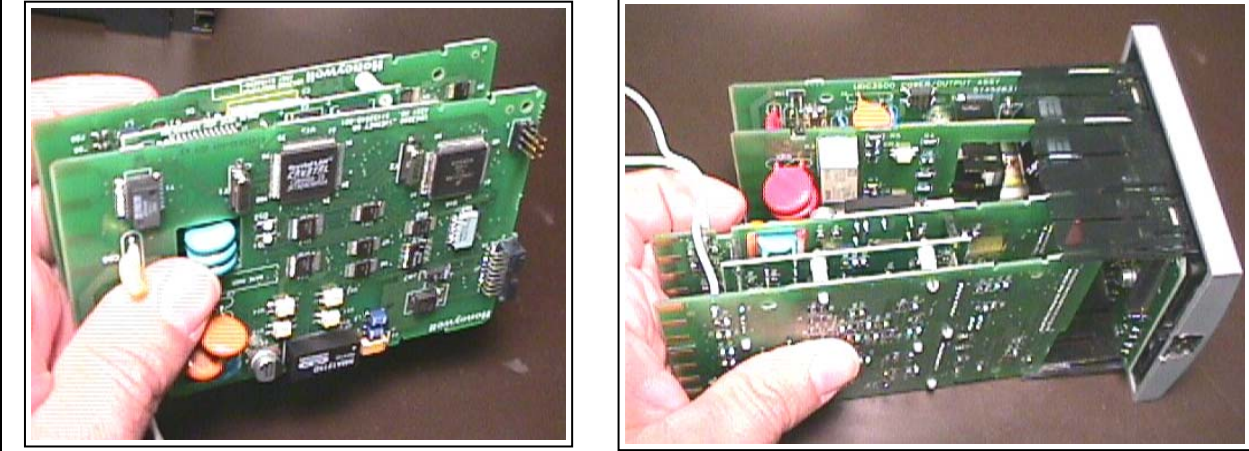

Chassis Reassembly Figure 10 Chassis Assembly

Make certain that the four larger boards are properly snapped into the top and bottom of the Chassis.

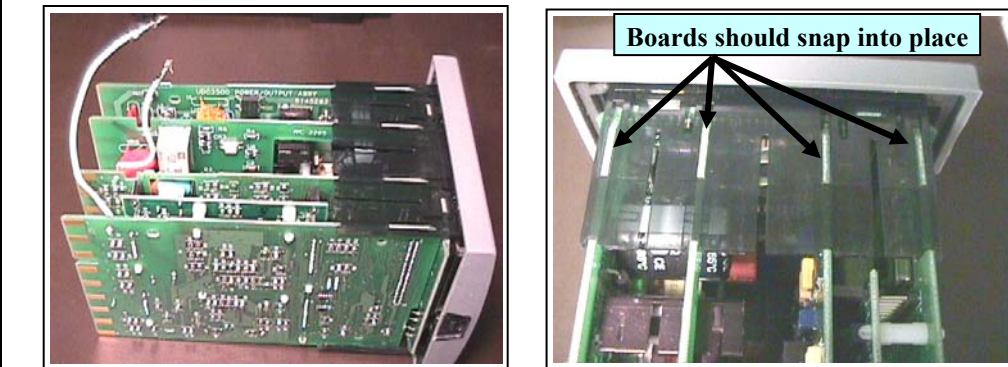

Continued on next page

Replacement Instruction, Continued

Chassis Reassembly Figure 11 WG1 Ground Wires

Plug the two ground wires onto the WG1 posts on the Power/Output Board. Wires must be routed through the board notches in order to ensure that they do not interfere when the chassis is plugged into the case.

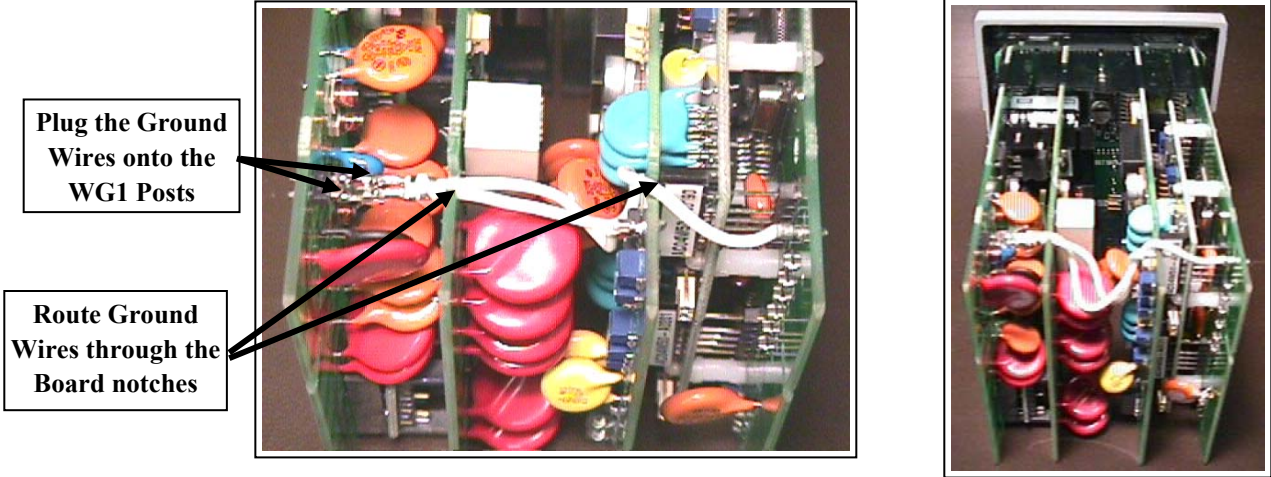

Ethernet Replacement

Table 5 Ethernet Board MAC and IP Information

Step	Action
1	Replacement Ethernet Boards have a label on them which show their MAC address. This is a unique value for each board.
2	All replacement Ethernet Boards have their IP address set to 10.0.0.2 as shipped from the Factory.