

EA002



2 / 10 / 50 TURN 1500A CLAMP COIL ADAPTER



OPERATION MANUAL

EA002

2 / 10 / 50 Clamp Coil Adapter

Operation Manual

Guarantee and service

Transmille Ltd. guarantees this instrument to be free from defects under normal use and service for a period of 1 years from purchase. This guarantee applies only to the original purchaser and does not cover fuses, or any instrument which, in Transmille's opinion, has been modified, misused or subjected to abnormal handling or operating conditions.

Transmille's obligation under this guarantee is limited to replacement or repair of an instrument which is returned to Transmille within the warranty period. If Transmille determines that the fault has been caused by the purchaser, Transmille will contact the purchaser before proceeding with any repair.

To obtain repair under this guarantee the purchaser must send the instrument in its original packaging (carriage prepaid) and a description of the fault to Transmille at the address shown below. The instrument will be repaired at the factory and returned to the purchaser, carriage prepaid.

Note :

TRANSMILLE ASSUMES NO RESPONSIBILITY FOR DAMAGE IN TRANSIT

THIS GUARANTEE IS THE PURCHASER'S SOLE AND EXCLUSIVE GUARANTEE AND IS IN LEIU OF ANY OTHER GUARANTEE, EXPRESSED OR IMPLIED. TRANSMILLE SHALL NOT BE LIABLE FOR ANY INCIDENTAL, INDIRECT, SPECIAL OR CONSEQUENTIAL DAMAGES OR LOSS.



Transmille Ltd.
Unit 4, Select Business Centre
Lodge Road
Staplehurst
Kent
TN12 0QW
United Kingdom

Tel : +44 0 1580 890700

Fax : +44 0 1580 890711

E-Mail : sales@transmille.com

Web : www.transmille.com

TABLE OF CONTENTS

GUARANTEE AND SERVICE	2
EA002 CLAMP COIL ADAPTER.....	4
THEORY OF OPERATION	4
HIGH ACCURACY DESIGN	5
CALCULATING CLAMP METER ACCURACY.	5
INNOVATIVE CLOSED CONSTRUCTION DESIGN.....	5
CONNECTION DIAGRAMS.....	6
<i>Terminal Configuration on rear of EA002 Coil Adapter</i>	<i>6</i>
<i>3000 Series 2A Terminals to 10 Turn Coil (Up to 20A simulation using coil).....</i>	<i>7</i>
<i>3000 Series 30A* Terminals to 10 Turn Coil (Up to 300A* simulation using coil).....</i>	<i>7</i>
<i>3000 Series 2A Terminals to 50 Turn Coil (Up to 100A simulation using coil).....</i>	<i>7</i>
<i>3000 Series 30A* Terminals to 50 Turn Coil (Up to 1500A* simulation using coil).....</i>	<i>8</i>
<i>3000 Series 2A Terminals to 2 Turn Coil (Up to 4A simulation using coil).....</i>	<i>8</i>
<i>3000 Series 30A* Terminals to 2 Turn Coil (Up to 60A* simulation using coil).....</i>	<i>8</i>
CARE & MAINTENANCE	9
<i>Cleaning the Adapter</i>	<i>9</i>
<i>Handling Precautions.....</i>	<i>9</i>
<i>Servicing Information</i>	<i>9</i>
Appendix A : Specifications	

EA002 Clamp Coil Adapter



- Calibrates Clamp Meters up to 1000Amps
- 2 / 10 / 50 Turn Coils
- High Accuracy Balanced Design
- Wide range of clamp sizes covered
- Complete with alignment table & connection leads

Designed for the calibration of both wound (AC only) & Magnetic field (hall effect) AC/DC clamp meters the Transmille current coil offers several unique features built in a robust construction.

Theory of Operation

The coil effectively multiplies the current produced by the calibrator by the number of turns of the coil, e.g. 2, 10, and 50 with the Transmille coil. The principle is each turn of the coil produces a magnetic field proportional to the current flowing in it. If you take 50 wires all side by side with the same current flowing in the same direction the magnetic field for each turn of wire will add together and produce a magnetic field 50 times stronger, e.g. the same magnetic field as one wire with 50 times the current flowing in it. By using a 50 turn coil it is possible to calibrate clamp meters up to 1000 Amps without having to actually generate more than 20 Amps (available from the 3000 Series calibrators). Clamp meters up to 3000 Amps can be calibrated when using Transmille's 50 Amp transconductance amplifier.

High Accuracy Design

Clamp meters can measure current by using the invisible magnetic field generated round any conductor carrying a current. The degree of magnetic coupling between the field produced by the conductor and the jaws of the clamp meter varies due to the position of the conductor within the jaws - this changes the current reading. Transmille's coil is designed to immerse both jaws of the clamp meter in the magnetic field while allowing the 'gap' or opening where magnetic flux will escape to protrude through the coil and stay out of the strongest part of the field. This makes the reading less dependent on the position of the clamp within the coil and also the quality of the jaw closing, allowing greater confidence in the calibration.

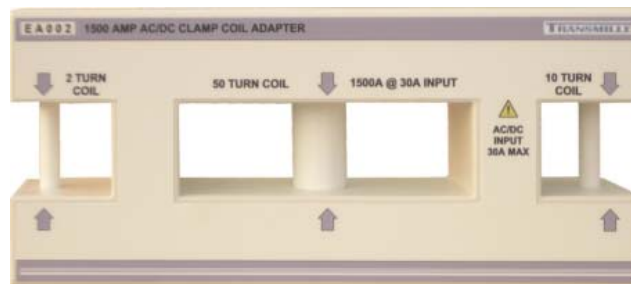

Calculating Clamp Meter Accuracy.

There are two contributions to the total accuracy which should be taken into account when calibrating clamp meters using a coil. The first is the accuracy of the current produced by the calibrator, the second is the coupling between the coil and clamp meter. These must be combined using a *root sum of the squares*. Empirical tests made on a wide range of clamp meters calibrated by Transmille at its laboratory have shown that *torroidal wound current transformer* type clamps typically exhibit better performance and will give coupling errors of 0.2% and *hall effect devices* slightly higher at around 0.4%.

Innovative Closed Construction Design

Three coils in one provide the ability to calibrate a wide range of coils, from small lower clamps down to 10mm jaw diameter to larger 2000A clamps. The low inductance, low resistance properties allow the calibrators to easily drive the coil, giving plenty of overhead for calibrating older clamps. The coils are fully enclosed in a strong, robust and compact plastic enclosure preventing mechanical damage. This rugged design is ideal for using the coil on-site and in harsh environments.



2 Turn Coil
Minimum 10mm inside
jaw diameter.



10 Turn Coil
Minimum 10mm inside
jaw diameter.



50 Turn Coil
Minimum 25.4mm inside
jaw diameter.

Connection Diagrams

Terminal Configuration on rear of EA002 Coil Adapter

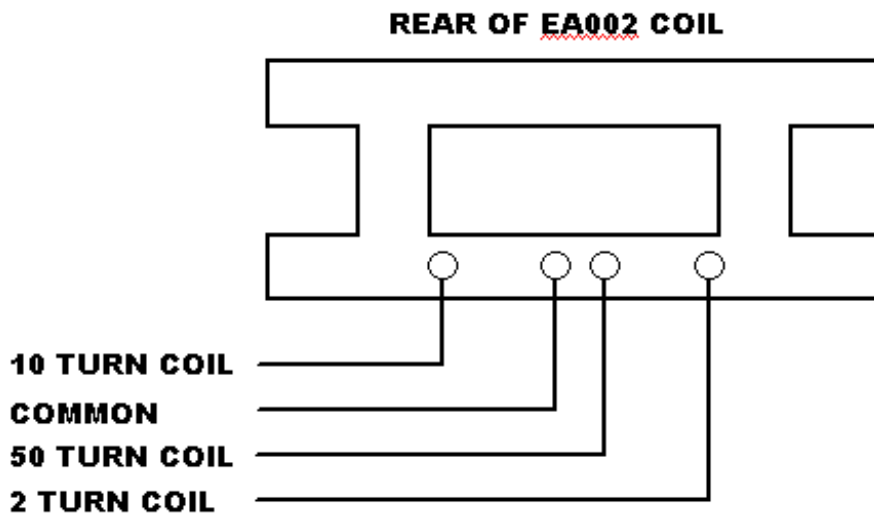

3000 Series 2A Terminals to 10 Turn Coil (Up to 20A simulation using coil)



3000 Series 30A* Terminals to 10 Turn Coil (Up to 300A* simulation using coil)

*20A output = 200A Simulation for 3050



3000 Series 2A Terminals to 50 Turn Coil (Up to 100A simulation using coil)

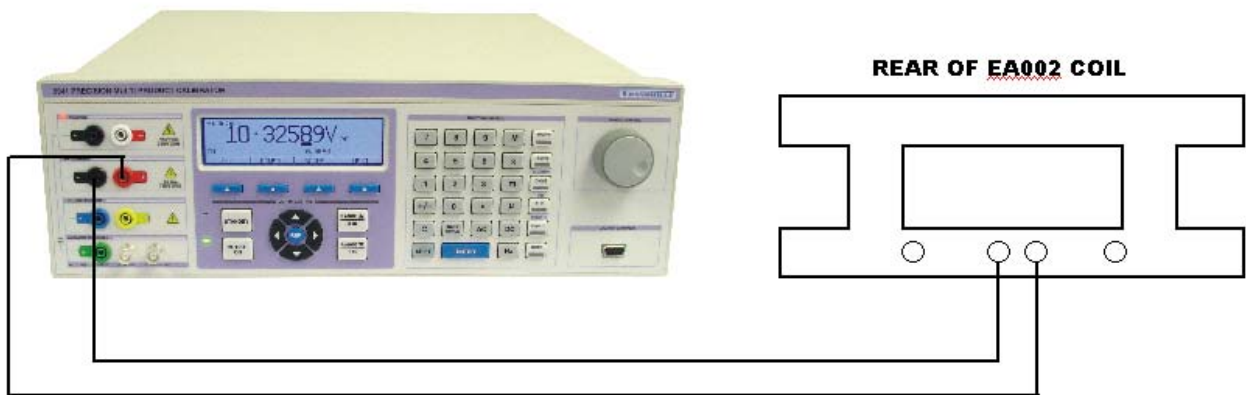

3000 Series 30A* Terminals to 50 Turn Coil (Up to 1500A* simulation using coil)

*20A output = 1000A Simulation for 3050

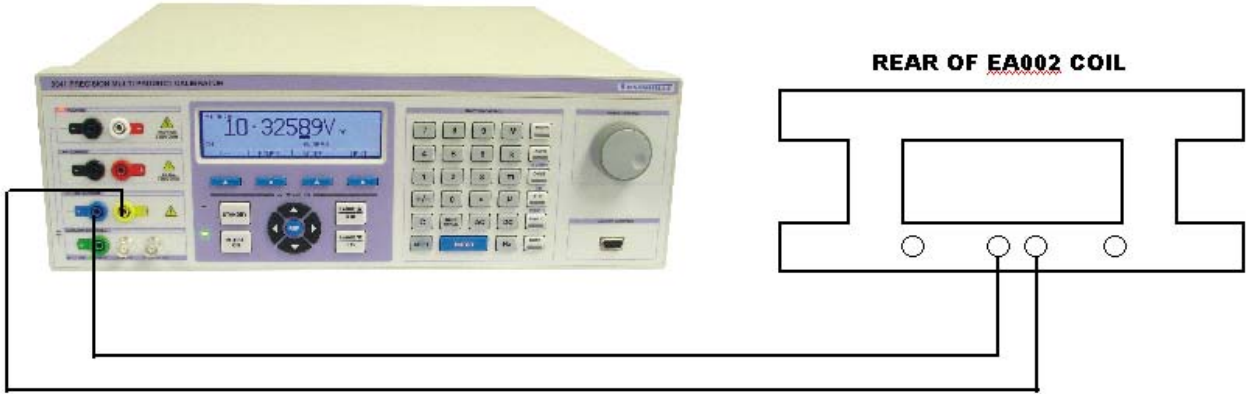

3000 Series 2A Terminals to 2 Turn Coil (Up to 4A simulation using coil)

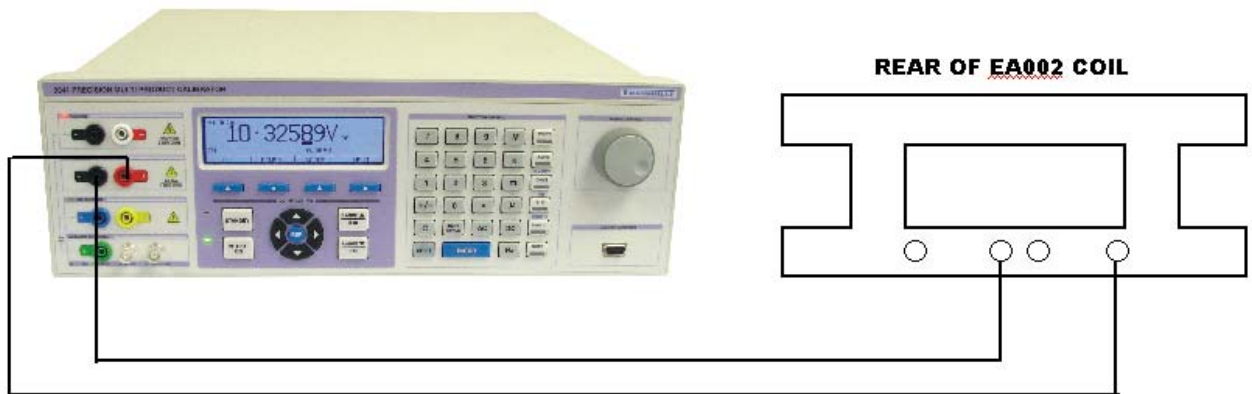

3000 Series 30A* Terminals to 2 Turn Coil (Up to 60A* simulation using coil)

*20A output = 40A Simulation for 3050



Care & Maintenance

The only maintenance instructions for the adapter is periodic cleaning.
See below for details on the cleaning procedure and precautions for handling.

Cleaning the Adapter

To keep the external enclosure of the adapter in good condition, clean the outer case with a soft cloth. Do not use any liquids in cleaning the enclosure – removal of surface dust is all that is recommended.

 **CAUTION**

Do not use cleaning fluids or solvents for cleaning as these may damage the enclosure and affect the plastic materials used in the adapter.

Handling Precautions

The adapter is designed for mechanical stability, but should not be subjected to excessive shock or be dropped. Transportation is recommended using the original packaging with avoidance of extreme changes of temperature.

Servicing Information

The adapter is provided certified from the factory, and uses precision components and are not user repairable. If the adapter is damaged it should be returned to the factory for repair and recalibration.

EA002

2 / 10 / 50 Clamp Coil Adapter

Appendix A

Specifications

EA002 2/10/50 Turn Clamp Coil Adapter Specifications

General Specifications	
Adapter Connection	4x 4mm safety sockets mounted on the rear of the unit
Adapter Dimensions	28cm x 12cm x 6cm
Colour	Cream
Connection to Calibrator	Via supplied 4mm to 4mm connection leads (x2) to 3000 series current terminals
Coil Configuration	2 Turn (LHS) : 10 Turn (RHS) : 50 Turn (CENTRE)
Coil Type	High accuracy balanced configuration
Min. internal jaw dimensions	10mm (2 Turn & 10 Turn) : 25mm (50 Turn)
Maximum Current	30A
Maximum RMS voltage	4V
Frequency Range	DC to 500Hz
Construction	Loose wound coil (for heat dissipation) in moulded ABS enclosure
Durability	Fully enclosed coil for maximum protection from mechanical damage
Compatibility	Designed for use with Transmille 3000 Series calibrators and ProCal Software

2 Turn Coil Accuracy (Input 0 to 30A : Freq. DC - 30Hz to 60Hz : Effective Output 0 to 60A)								
	90 Day Rel.		180 Day Rel.		1 Year Rel.		2 Year Rel.	
	%	A	%	A	%	A	%	A
Effective accuracy - Coil only (wound clamps)	0.35	+ 0.008	0.35	+ 0.008	0.35	+ 0.008	0.35	+ 0.008
Effective accuracy - Coil only (hall effect clamps)	0.48	+ 0.07	0.48	+ 0.07	0.48	+ 0.07	0.48	+ 0.07
Total uncertainty with 3050 (All clamps)	0.51	+ 0.09	0.51	+ 0.09	0.52	+ 0.09	0.56	+ 0.10
Total uncertainty with 3041 (wound clamps)	0.36	+ 0.028	0.36	+ 0.028	0.36	+ 0.028	0.38	+ 0.036
Total uncertainty with 3041 (hall effect clamps)	0.49	+ 0.090	0.49	+ 0.090	0.49	+ 0.090	0.50	+ 0.098
Total uncertainty with 3010 calibrator (wound clamps)	0.36	+ 0.010	0.36	+ 0.010	0.36	+ 0.010	0.37	+ 0.010
Total uncertainty with 3010 (hall effect clamps)	0.48	+ 0.072	0.49	+ 0.072	0.49	+ 0.072	0.49	+ 0.072

10 Turn Coil Accuracy (Input 0 to 30A : Freq. DC - 30Hz to 60Hz : Effective Output 0 to 300A)								
	90 Day Rel.		180 Day Rel.		1 Year Rel.		2 Year Rel.	
	%	A	%	A	%	A	%	A
Effective accuracy - Coil only (wound clamps)	0.41	+ 0.01	0.41	+ 0.01	0.41	+ 0.01	0.41	+ 0.01
Effective accuracy - Coil only (hall effect clamps)	0.59	+ 0.11	0.59	+ 0.11	0.59	+ 0.11	0.59	+ 0.11
Total uncertainty with 3050 (All clamps)	0.61	+ 0.13	0.62	+ 0.13	0.62	+ 0.13	0.65	+ 0.14
Total uncertainty with 3041 (wound clamps)	0.42	+ 0.03	0.42	+ 0.03	0.42	+ 0.03	0.43	+ 0.04
Total uncertainty with 3041 (hall effect clamps)	0.60	+ 0.13	0.60	+ 0.13	0.60	+ 0.13	0.61	+ 0.14
Total uncertainty with 3010 calibrator (wound clamps)	0.41	+ 0.012	0.42	+ 0.012	0.42	+ 0.012	0.42	+ 0.012
Total uncertainty with 3010 (hall effect clamps)	0.59	+ 0.112	0.59	+ 0.112	0.60	+ 0.112	0.60	+ 0.112

50 Turn Coil Accuracy (Input 0 to 30A : Freq. DC - 30Hz to 60Hz : Effective Output 0 to 1500A)								
	90 Day Rel.		180 Day Rel.		1 Year Rel.		2 Year Rel.	
	%	A	%	A	%	A	%	A
Effective accuracy - Coil only (wound clamps)	0.24	+ 0.04	0.24	+ 0.04	0.24	+ 0.04	0.24	+ 0.04
Effective accuracy - Coil only (hall effect clamps)	0.45	+ 0.42	0.45	+ 0.42	0.45	+ 0.42	0.45	+ 0.42
Total uncertainty with 3050 (All clamps)	0.48	+ 0.44	0.48	+ 0.44	0.49	+ 0.44	0.53	+ 0.45
Total uncertainty with 3041 (wound clamps)	0.25	+ 0.06	0.26	+ 0.06	0.26	+ 0.06	0.28	+ 0.07
Total uncertainty with 3041 (hall effect clamps)	0.46	+ 0.44	0.46	+ 0.44	0.46	+ 0.44	0.47	+ 0.45
Total uncertainty with 3010 calibrator (wound clamps)	0.25	+ 0.042	0.25	+ 0.042	0.25	+ 0.042	0.26	+ 0.042
Total uncertainty with 3010 (hall effect clamps)	0.45	+ 0.42	0.46	+ 0.42	0.46	+ 0.42	0.46	+ 0.42

Accuracy is dependant on proper alignment of the clamp meter within the coil
 Certain clamp meters have alignment marks which should be aligned with the centre of the coil.
 Certain types of clamp meter may have additional errors, or be outside the range which can be driven by the 3041/3010 directly

**Uncertainty calculated as the square root of the square of coil accuracy + square of calibrator accuracy
 using empirical data obtained for both wound & hall effect instruments from a wide range of manufacturers
 Clamp coil adaptor is supplied complete with workstation incorporating alignment marks (size 275x295x45mm)**

EA002 2/10/50 Turn Clamp Coil Adapter Specifications (Cont'd)

DC Resistance	
At Coil	0.09Ω
With Connection Leads	0.1Ω

Duty Cycle	
10A	Continuous
20A	2mins on ~ 5mins off
30A	30secs on ~ 5mins off

Inductance	
Coil Only	120uH
Coil with typical clamp meter on 50 Turn coil	200uH
Coil with typical clamp meter on 10 Turn coil	50uH
Coil with typical clamp meter on 2 Turn coil	5uH

Specifications apply between 17°C and 27°C.

Outside this range an allowance of 0.18 x 1 Year Spec. per °C should be added.

Due to continuous development specifications may be subject to change.