

Installing the Sensor

!WARNING!

Before performing service or maintenance operations on the systems, turn OFF main power switches to the unit. Electric shock can cause personal injury. Please read and follow the wiring instructions precisely; miswiring may cause permanent damage to the product.

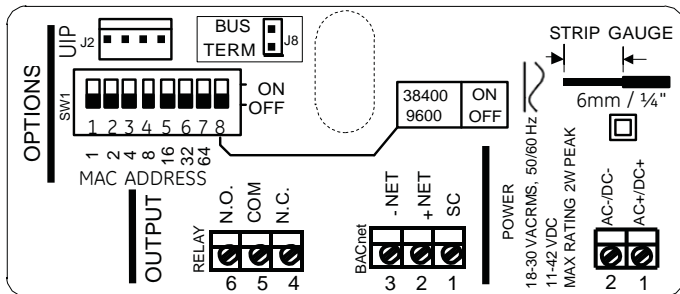
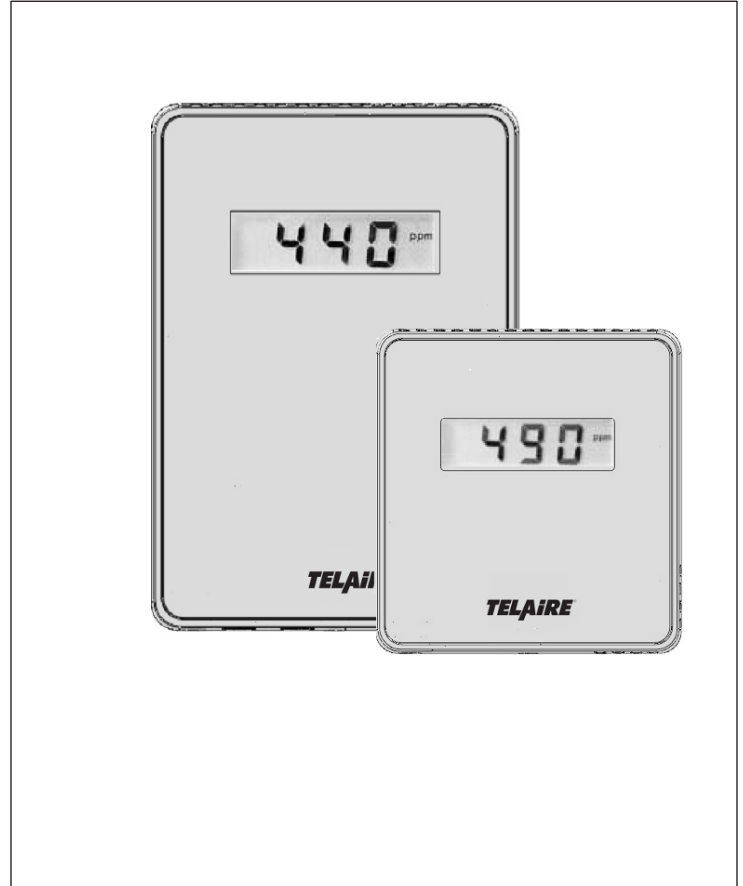
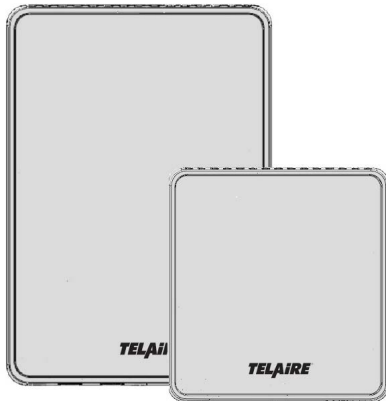

Internal Label

Basic Installation for Devices

1. Separate the case into its front and rear sections.
2. Secure the rear section of the case to the wall or junction box using the supplied screws, and make necessary wire connections.
3. Mount the Controller on the base by aligning the top clips and then securing to the bottom clips. Secure the Ventostat with the supplied set screw. A one-minute stabilization warmup will take place.
4. When fitting the T8300 (pitot tube version), complete the installation by screwing the tube connectors to the input ports on the sensor. The tubing connectors can be attached to either input port. It will not affect the performance of the sensor. (See page 3 for further instructions.)

MAC Address

Users select the MAC address by using the left most 7 DIP switches found at the top of the unit. The switches are such that in the up position (ON), address numbers are added. For example, with switches 1, 3 and 5 on, the MAC address is 21 (1+4+16). MAC address 0 is typically assigned to the BACnet router, with devices sequentially added from 1 to 127.

Baud Rate

Users select the baud rate by the right most DIP switch number 8; the baud rate will be 38400 when switch is ON, and 9600 baud when OFF. Other baud rates are selectable by Analog Value Object 7 (AV-7) over BACnet.

Devices with digital display will show Baud Rate and MAC Address for a few seconds when first powered.

Ventostat Wiring Example

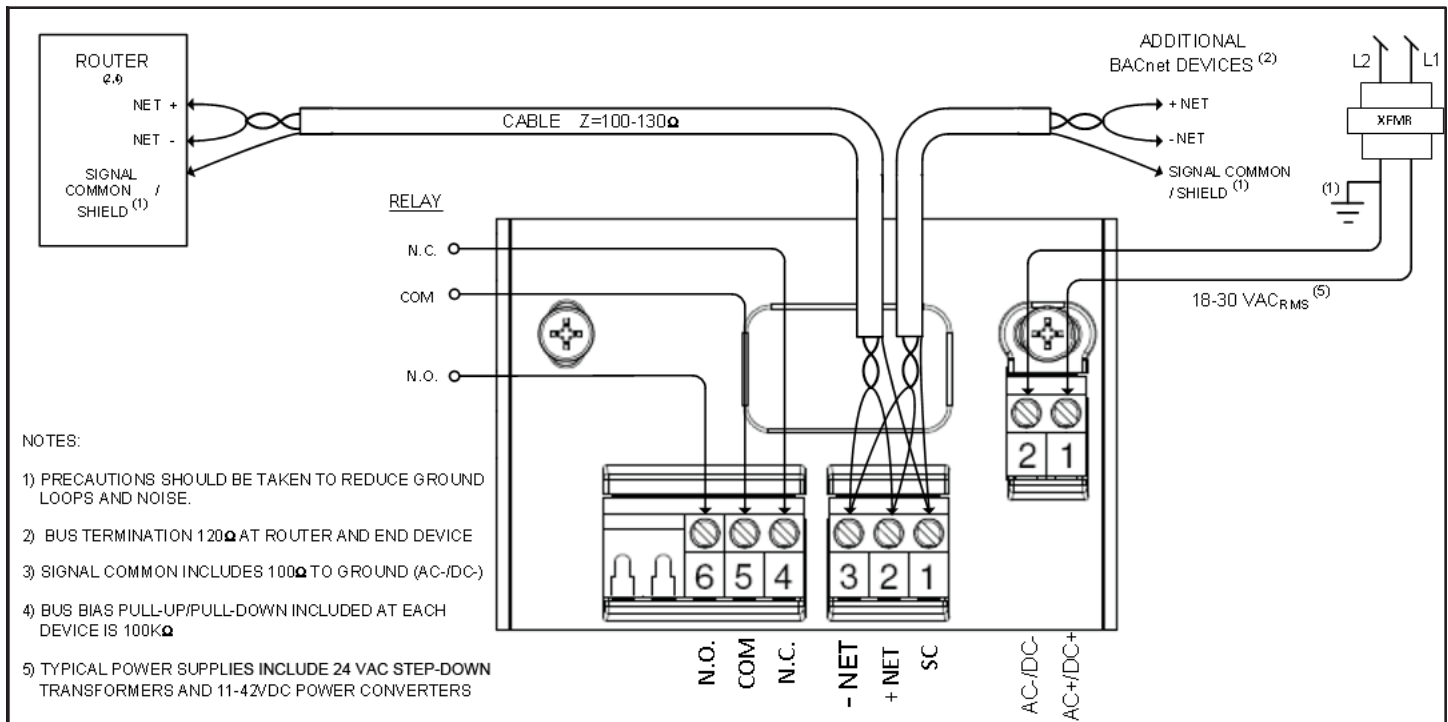

BACnet Object Table

Object Type	Object Identifier	Object Name	Default	Range	Units
Device	568000 ⁽¹⁾	Telaire BACnet Transmitter	568000	568000-568127	-
Analog Inputs	AI-1	CO ₂	Present Value	0-65535	ppm
	AI-2	Relative Humidity	Present Value	0-100	%
	AI-3	Temperature, ChipCap	Present Value	32-122/0-50	°F/°C
	AI-4	Temperature, Thermistor	Present Value	32-122/0-50	°F/°C
Analog Values	AV-1	Temperature Offset	-0.40	-50 to +50	°C ⁽³⁾
	AV-2	RH Offset	0.30	-100 to +100	%
	AV-3	Relay Set Point ⁽⁶⁾	1000	0-65535	ppm
	AV-4	Relay Hysteresis ⁽⁶⁾	80	0-65535	ppm
	AV-5	Elevation	0	0-65535	meters ⁽⁴⁾
	AV-6	Calibration, Single Point	1000	0-65535	ppm
	AV-7	Baud Rate	9600	9600-76800	bps ⁽⁵⁾
	AV-8	MAC Address	DIP Switches	0-127	-
Binary Input	BI-1	Relay State ⁽⁶⁾	0	0/1	OFF/ON
Binary Values	BV-1	Temperature Units	1	0/1	°C/°F
	BV-2	ABC Logic State	1	0/1	OFF/ON
	BV-3	ABC Logic Reset	0	0/1	Normal/Reset
	BV-4	CO ₂ Calibration	0	0/1	Normal/Calibrate

NOTES:

(1) The Object Identifier Value is a concatenation of Vendor Identification number (i.e., 568) and MAC address (i.e., 000-127), as read from the hardware DIP switches.

(2) The temperature units displayed or read from the unit are dependent on product options programmed during manufacture or over BACnet.

(3) Temperature offset is always represented in degree Celsius regardless of the product options (i.e., temperature representation in degree Fahrenheit or degree Celsius).

(4) Elevation is always in meters

(5) Bits-per-second. 38.4 kBd would be represented as 38400.0.

(6) Command is available, but will have no effect if the correct option is not ordered with product.

Sensing Duct CO2 Concentrations

Duct-Mounting the Enclosures

Ventostat products can be installed inside the return air ductwork, if needed. As an alternative, please consider the T8031 unit. When mounting these products inside the ductwork, seal the hole around the wires and leave the duct insulation in place to prevent condensation which may damage the sensor.

Pitot Tube Installation for T8300 and T8300-D

Install the mounting bracket, then install the pitot tube assembly as follows:

Note: *The length of the Tygon® tubing is 6 ft. (1.8 m) with the optional T62892 pitot kit for the T8300. In order to maintain optimum accuracy, the tubing should not be lengthened. If the sensor is mounted closer than 3 ft. (0.9 m) the excess tubing should be shortened to avoid interference with mechanical or moving devices.*

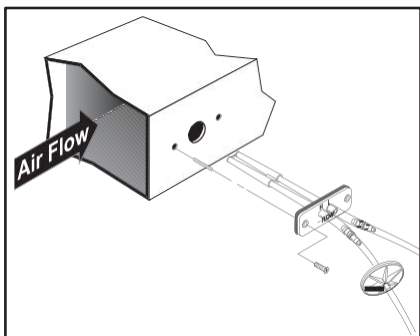

1. To mount the pitot tube, drill one 7/8" hole through the duct.
2. Insert the pitot tube and mark the two remaining holes for the mounting screws.
3. Punch or drill the two marked holes.
4. Note the direction of airflow in the duct.
5. Note the marking on the pitot tube flange and insert so that it is properly aligned with the airflow.
6. To ensure an air tight seal, make sure the mounting surface of the duct is clear of dirt or obstructions. Then, attach the pitot tube to the duct with sheet metal screws or rivets.
7. Check the length of the tubing before attaching to the sensor. The tubing should connect without stretching or pulling. If the length is long enough to create a loop or bind in the tubing, it should be shortened.
8. To shorten the tubing, remove the connectors that attach to the sensor and cut the tubing to length.
9. Replace the tubing connectors by using a twisting or screwing motion. Verify the connection is secure.

Note: *If the tubing length has been shortened, be sure the in-line filter is replaced on the pitot tube connector marked with an "H".*

Accessory Enclosures

Model T1508 Duct Mount Enclosure (Aspiration Box)

The T8100/T8200/T8300 units can be installed inside a Model 1508 Duct Mount Enclosure.

Model T1552 Outside Air Measurement Enclosure

This NEMA-3R weather resistant enclosure includes thermostat and allows installing the sensor in environments with temperatures down to -40°F.

Model T1505 Harsh Environment Enclosure

For extreme environments where the sensor might be subjected to condensation or water spray such as those found in greenhouses or breweries- NEMA-3R rated.

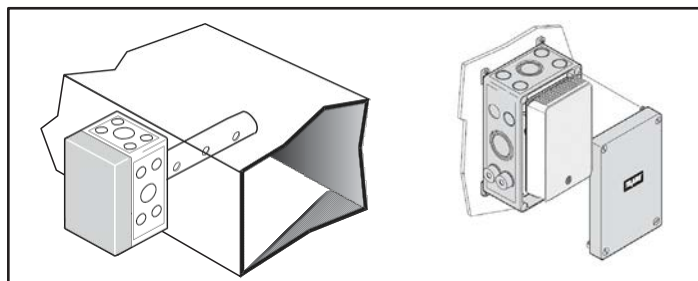

Ventostat Specifications

Sensing Method

Non-dispersive infrared (NDIR) absorption
Gold-plated optics
Patented ABC Logic self calibration algorithm

CO2 Measurement Range

T8100/T8200/T8300
0 to 2000 ppm (0 ppm = 0 V, 4 mA; 2000 ppm = 10/5V, 20 mA)
T8100/T8200/T8300 - 5P models
0 to 5000 ppm (0 ppm = 0 V, 4 mA; 5000 ppm = 10/5V, 20 mA)
T8200 (10P models) 0 to 10,000 ppm (0 ppm = 0 V, 4 mA;
10,000 ppm = 10/5V, 20 mA)
T8200 (20P models) 0 to 20,000 ppm
(0 ppm = 0 V, 4 mA; 20,000 ppm = 10/5V, 20 mA)

CO2 Accuracy

T8100/T8300 - Single Channel
400-1250 ppm ±30 ppm +3% of reading*,**
1250-5000 ppm ±5% of reading + 30ppm*,**

T8200 - Dual Channel
75 ppm or 10% of reading (whichever is greater)

*Tolerance based on span gas of ±2%

** ABC Logic not deactivated

Power Supply Requirements

18-30 VAC RMS, 50/60 Hz, or 11 to 42 VDC, polarity protected*

Note: *Typical power supplies include 24 VAC step-down transformers and 11-42VDC power converters.*

Power Consumption

Typical 1W at nominal voltage of 24V AC RMS

Temperature Dependence

0.2% FS per °C ($\pm 0.11\%$ per °F)

Stability

T8100/T8300 - Single Channel
<2% of FS over life of sensor (15 years)

T8200 - Dual Channel
<5% of FS or <10% reading annual over life of sensor (10 years)

Pressure Dependence

0.135% of reading per mm Hg

Certifications

CE and RoHS compliant
BTL Certified
Meets requirements of UL 61010-1*
CB Scheme compliant*
*test report available upon request

Signal Update

Every 5 seconds

CO₂ Warm-up Time

< 2 minutes (operational)
10 minutes (maximum accuracy)

Operating Conditions

32°F to 122°F (0°C to 50°C)
0 to 95% RH, non-condensing

Storage Conditions

-40°F to 158°F (-40°C to 70°C)

Flammability Classification

UL94 5VA

Thermistor Type

NTC 10 K Ω thermistor (Linearized)

Thermistor Accuracy

$\pm 1^\circ\text{C}$

RH Sensing Element

Capacitive polymer sensor

RH Range

0% to 99% RH (non-condensing)

RH Accuracy (25°C)

$\pm 2.5\%$ RH ($\leq 60\%$ RH)
 $\pm 3.5\%$ RH ($\geq 70\%$ RH)
 $\pm 2.0\%$ RH Hysteresis

Active Temperature Accuracy

$\pm 0.8^\circ\text{C}$ @ 22°C

Active Temperature Range

0 to 50°C

ABC Logic™ Self Calibration System

ABC Logic™ (Automatic Background Calibration) self-calibration allows the sensor to continually recalibrate itself when the indoor concentrations drop to outside levels while the building is unoccupied. Generally a building must be regularly unoccupied for 4 hours or more for this self-calibration system to operate properly. Under these conditions, ABC Logic™ should maintain sensor calibration over the lifetime of the sensor. The ABC Logic™ should be turned OFF where a building is continuously occupied 24 hours per day, or where there could be significant sources of non-occupant related CO₂ such as greenhouses, breweries and other industrial and food processing applications.

Outputs

BACnet
MS/TP
RS485
Baud rates 9600 and 38400 (19200 and 76800 programmable)

Relay
SPDT
1.0 max at 30VDC, Resistive
Threshold 1000 ppm (default)
Hysteresis 80 ppm (default)



BACnet is a registered trademark of ASHRAE. ASHRAE does not endorse, approve or test products for compliance with ASHRAE standards. Compliance of listed products to requirements of ASHRAE Standard 135 is the responsibility of the BTL Testing Laboratory. BTL is a registered trademark of the BTL Testing Laboratory.

Note: Accuracy of RH and temperature measurements may vary due to operation of the relay. Users should understand the impact of the desired relay operation on sensor performance prior to installation and operation.

Explanation of Symbols on Terminal Label

Symbol	Description
	The unit is double insulated from the Main when combined with an external transformer/power supply.
	The unit can operate on AC and DC within specified range.

Warranty/Other

Warranty

18 months parts and labor

This product is covered by one or more of the following patents:
5,650,624 / 5,721,430 / 5,444,249 / 5,747,808 / 5,834,777 / 5,163,332 /
5,340,986 / 5,502,308 / 6,344,798 / 6,023,069 / 5,370,114 / 5,601,079 /
5,691,704 / 5,767,776 / 5,966,077 / 6,107,925 / 5,798,700 / 5,945,924 /
5,592,147 / 6,255,653 / 6,250,133 / 6,285,290

Warranty Repairs

Amphenol Advaced Sensors will repair Telaire product that fails to meet the terms provided for in the Return and Warranty Policy Statement (See, <http://www.telaire.com>). Warranty period shall start from date of manufacture and be based on product category and type of equipment as specified in Table 1: Product Warranty Periods. For all warranty repairs, Amphenol Advaced Sensors will bear all product repair parts, labor, and standard ground shipping charges.

Contact

www.telaire.com
North America and Asia +1 814 834 9140
Europe +44 1823 335 200