

# Flap-Type Flowmeter



measuring  
•  
monitoring  
•  
analyzing

TSK



Fieldbus  
Foundation



- Range: 6.6...26.4 to 880...6600 GPM
- Accuracy:  $\pm 2.5\%$  of Full Scale
- $P_{max}$ : 580 PSI
- $T_{max}$ : -40 ...572 °F
- Connection: Wafer Flange 1.5" ...20" ASME
- Material: Stainless Steel, Hastelloy C<sup>®</sup>, PTFE
- Options: Limit Contacts, Analog Output with HART<sup>®</sup> or PROFIBUS-PA<sup>®</sup> Counter



KOBOLD companies worldwide:

ARGENTINA, AUSTRALIA, AUSTRIA, BELGIUM, BULGARIA, CANADA, CHILE, CHINA, COLOMBIA, CZECH REPUBLIC, EGYPT, FRANCE, GERMANY, HUNGARY, INDIA, INDONESIA, ITALY, MALAYSIA, MEXICO, NETHERLANDS, PERU, POLAND, REPUBLIC OF KOREA, ROMANIA, SINGAPORE, SPAIN, SWITZERLAND, TAIWAN, THAILAND, TUNISIA, TURKEY, UNITED KINGDOM, USA, VIETNAM

KOBOLD Instruments, Inc.  
1801 Parkway View Drive  
Pittsburgh, PA 15205  
Main Office:  
1.800.998.1020  
1.412.788.4890  
info@koboldusa.com  
www.koboldusa.com



### Description

The KOBOLD TSK measures liquid flow in pipes and can be used in all directions of flow. It shows the current flow rate in volume or mass per unit in time. It is designed to handle difficult and adverse operating conditions. It is available with electronic options for remote process monitoring and control. The principal of operation is as follows: If a media flows with sufficient velocity through the horizontally or vertically mounted TSK fitting, the paddle swivels around the axle until the force of the media and the opposing force of the paddle surface plus the spring tension establish equilibrium. The angular position, or the position of equilibrium of the paddle in the measuring compartment, is the measure for the flow. The encapsulated ring-type permanent magnet at the end of the paddle axis transmits this position to the scale and the optional electronic evaluators through the magnet tracking indicator system. This happens safely and without packing glands. The flow rates shown on the scale only apply to the calibrated media or to a media with the same physical characteristics.



### Specifications

#### Sensor Materials:

- TSK-S:** 316L SS / 316-Ti SS
- TSK-H:** Hastelloy C-22® / Hastelloy C-22®
- TSK-P:** PTFE / Hastelloy C-22®
- Option:** Others on Request, Consult Factory

- Process Connection:** Wafer Acc. EN 1092, ASME B16.5, DIN 2512, Special Connections on Request

#### Nominal Pressure

- TSK-S/H:** 580 PSIG ASME CI150 or 300 (Standard)
- TSK-P:** 232 PSIG ASME CI150 (Standard)  
Higher Pressure Rates Optional

#### Process Temperature:

- TSK-S/H:** -40...572 °F
- TSK-P:** -4...257 °F

- Ambient Temperature:** -40...176 °F

- Ingress Protection:** IP 65 (EN60529)

- Accuracy (Liquid):** ± 2.5% of Full Scale  
± 0.2% with Transmitter (ES)

- Repeatability:** ± 0.5%

- Certification:** Explosion Protection:  
BVS 03 ATEX H/B 112  
CE-Marking: Pressure Equipment  
Directive 97/23/EC

#### Display

- Materials:** Aluminum (Enameled)  
Stainless Steel (Option)
- Outputs:** Inductive Switch or Microswitch

- Ambient Temperature:** -40...176 °F (without Switch)  
-40...149 °F (with Switch)

#### Transmitter

- ES with HART®-Protocol
- ES with HART®-Protocol and 2 NAMUR-Switches
- ES with PROFIBUS-PA®
- ES with HART®-Protocol and Counter Module

#### Power Supply:

14 - 30 V<sub>DC</sub>

#### Output:

Passive, Galvanically Isolated

- Current:** 4-20 mA

#### Binary 1 and 2:

U<sub>i</sub>=30 V, I<sub>i</sub>=20mA, P<sub>i</sub>=100 mW

#### Input Binary:

Counter Reset (only for ES with Counter Module)

#### Ambient Temperature:

-40...158 °F

#### Ingress Protection:

IP 65 (EN60529)

#### Certification

- Explosion Protection:** DMT 00 ATEX E 075

#### Type of Protection:

II 2G EEx ia IIC T6

#### CE-Marking:

Explosion Protection Directive

94/9/EC



Order Details (Example: TSK-S 205R B1 U 6 V 00 S 5 0)

Model	Process Connection	Water Range (GPM)	Flow Direction	Temperature Class	Seal	
TSK-S.. = Armature and Built-in Parts Stainless Steel	..205R.. = 1-1/2" Class 150	..B1.. = 6.6...26.4 ..B2.. = 6.6...44 ..B3.. = 13.2...66	..U.. = From the Bottom to the Top  ..O.. = From the Top to the Bottom  ..L.. = From the Left to the Right  ..R.. = From the Right to the Left	..2.. = Max. 572 °F, Magnet Encapsulation Stainless Steel, Forward Advanced Display  ..3.. = Max. 392 °F, Magnet Encapsulation Stainless Steel, Forward Advanced Display  ..4.. = Max. 275 °F, Magnet Encapsulation PVDF, Forward Advanced Display  ..5.. = Max. 212 °F, Magnet Encapsulation PVDF	..V.. = FKM (Max. 302 °F)  ..F.. = FEP (Max. 392 °F)  ..S.. = Stainless Steel (Max. 572 °F)	
	..225R.. = 1-1/2" Class 300					
	..206R.. = 2" Class 150	..C1.. = 6.6...44 ..C2.. = 13.2...132				
	..226R.. = 2" Class 300					
	..207R.. = 2-1/2" Class 150	..D1.. = 6.6...61.6 ..D2.. = 17.6...132 ..D3.. = 26.4...220				
	..227R.. = 2-1/2" Class 300					
	..208R.. = 3" Class 150	..E1.. = 17.6...106 ..E2.. = 44...264				
	..228R.. = 3" Class 300					
	..210R.. = 4" Class 150	..F1.. = 26.4...176 ..F2.. = 35.2...352				
	..230R.. = 4" Class 300					
	..211R.. = 5" Class 150	..G1.. = 44...264 ..G2.. = 88...528				
	..231R.. = 5" Class 300					
TSK-H.. = Armature and Built-in Parts Hastelloy C-22®	..212R.. = 6" Class 150	..H1.. = 66...440 ..H2.. = 132...880				
	..232R.. = 6" Class 300					
	TSK-P³.. = Armature PTFE, Built-in Parts Hastelloy C-22®	..213R.. = 8" Class 150	..J1.. = 110...704.5 ..J2.. = 220...1211 ..J3.. = 264...1760			
		..214R.. = 10" Class 150	..K1.. = 220...880 ..K2.. = 330...1760 ..K3.. = 352...2202			
	..215R.. = 12" Class 150	..L1.. = 352...1760 ..L2.. = 440...2640				
	..216R.. = 14" Class 150	..M1.. = 528...3082 ..M2.. = 660...4400				
	..217R.. = 16" Class 150	..N1.. = 660...3520 ..N2.. = 880...5724				
	..219R.. = 20" Class 150	..P1.. = 880...5724 ..P2.. = 880...6605				
Special Seal	Certificate	Display	Scale	ElectricalOutputs		
(For protection against incoming solids, ie; metal shavings and small debris, from entering the transmission chamber.)  ..0.. = Without  ..1.. = FKM, Max 302°F  ..2.. = FEP, Max 392°F	..0.. = Without  ..1.. = Certificate of Compliance with the Order 2.1  ..2.. = Test Report 2.2  ..B.. = Inspection Certificate 3.1  ..C.. = Inspection Certificate 3.2	..S.. = Standard (Aluminum)  ..E.. = Stainless Steel Display IP 67  ..T.. = Standard (Aluminum) with Pressure Compensation	..1.. = %-Scale (Water)  ..2.. = Range-Scale (Water)  ..4.. = %-Scale (Media)  ..5.. = Range-Scale (Media)  ..F.. = Dual-Scale (Media) Customer Preference	..0 = Without  ..1 = 1x Inductive Limit Contact  ..2 = 2x Inductive Limit Contacts  ..6 = Electr. Transmitter ES, HART® Protocol, 4-20 mA, EEx ia  ..7 = Electr. Transmitter ES, HART® Protocol, 4-20 mA, EEx ia, 2x Namur Contacts  ..9 = Electr. Transmitter ES, PROFIBUS-PA®, EEx ia  ..C = 1x Microswitch Limit Contact  ..D = 2x Microswitch Limit Contacts  ..E = 1x PNP Transistor Limit Contact  ..F = 2x PNP Transistor Limit Contacts  ..I = 4-20 mA w/ HART® and Counter Module  ..K = 4-20 mA with Fieldbus Foundation		

³TSK-P max. 257 °F



## Flap Style Flowmeter Model TSK

### Dimensions

Size (inch)	Nominal Pressure (Standard)	L (inch)		D (inch)	h (inch)
		Display Aluminium	Display Stainless Steel		
ASME	Class			ASME- Flange	
2	300	10.71	10.28	3.63	0.67
2-1/2	300	10.71	10.28	4.02	0.83 (ASME = 0.67)
3	300	10.71	10.28	5.00	1.22
4	150	10.71	10.28	6.22	1.42
5	150	13.85	13.43	7.32	1.77
6	150	13.85	13.43	8.35	2.09
8	150	13.85	13.43	10.55	3.15
10	150	13.85	13.43	12.60	3.54
12	150	14.65	14.21	15.00	3.94
14	150	17.40	16.97	16.26	3.94
16	150	17.79	17.36	18.50	5.12
20	150	19.37	18.94	23.03	5.12

### Standard Display for Horizontal Flow

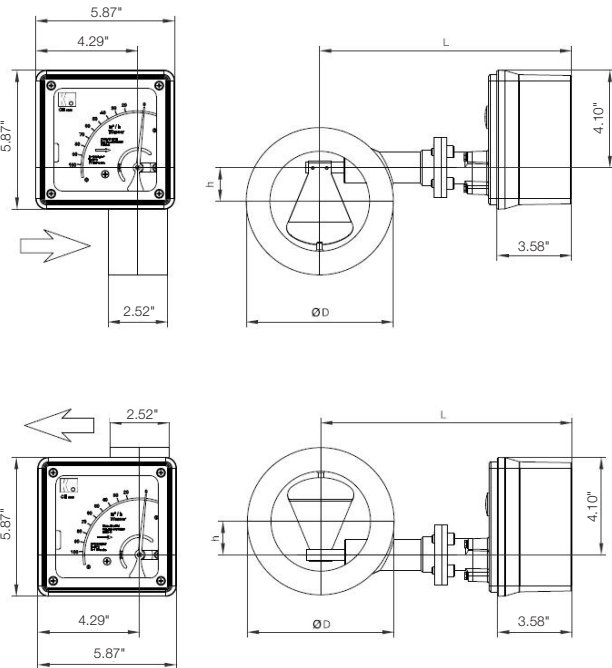

### Standard Display for Vertical Flow

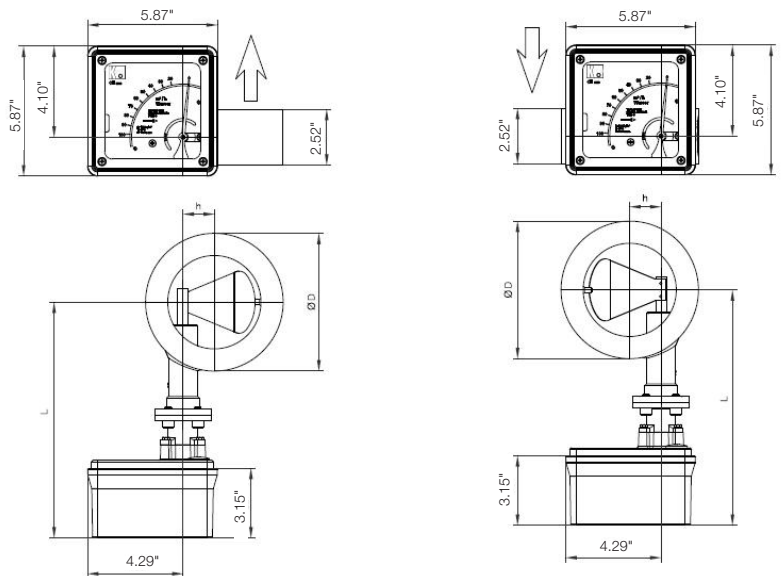

Size (inch)	Nominal Pressure (Standard)	L (inch)		D (inch)	h (inch)
		Display Aluminium	Display Stainless Steel		
2	300	10.71	10.28	3.63	0.67
2-1/2	300	10.71	10.28	4.02	0.83 (ASME = 0.67)
3	300	10.71	10.28	5.00	1.22
4	150	10.71	10.28	6.22	1.42
5	150	13.85	13.43	7.32	1.77
6	150	13.85	13.43	8.35	2.09
8	150	13.85	13.43	10.55	3.15
10	150	13.85	13.43	12.60	3.54
12	150	14.65	14.21	15.00	3.94
14	150	17.40	16.97	16.26	3.94
16	150	17.79	17.36	18.50	5.12
20	150	19.37	18.94	23.03	5.12

**Stainless Steel Display for Horizontal Flow**

**Stainless Steel Display for Vertical Flow**

