



Level



Pressure



Flow



Temperature

Liquid
Analysis

Registration

Systems
Components

Services



Solutions

Technical Information

Omnigrad S TR65

RTD thermometer EEx-d or EEx-ia certified, no replaceable insert, process connection: threaded welded and threaded compression fitting. PCP (4...20 mA), HART® or PROFIBUS-PA® electronics



Range of uses

The Omnigrad S TR65 is an RTD industrial thermometer, developed for use in the fine chemicals and petrolchemical industry but also suitable for generic industrial applications. In compliance to EN 50014/18/20 (ATEX certification) it is therefore particularly suitable also for hazardous areas.

When required, it's also available with a transmitter (PCP, HART® or PROFIBUS-PA®) into the housing.

The TR65 is available in different configurations, can also be configured with specific dimensions and characteristics depending on process requirements.

The installation on the plants normally needed a special process connection: a compression fitting.

Application areas

- Fine chemicals industry
- Petrochemical industry
- Light energy industry
- General industrial services
- Environmental engineering

Features and benefits

- Customized immersion length
- Aluminium housing, with protection grade from IP66 to IP68
- Mineral oxide insulated insert (MgO cable) diameter: 3 or 4, 5 or 6 or 8 mm
- Process connection fixed under housing or sliding and spring loaded on the insert sheath (inox compression fitting)
- PCP, HART® and PROFIBUS-PA®, (4...20 mA 2-wire transmitters into the housing)
- The accuracy of the sensing element (Pt100) is: class A or 1/3 DIN B (IEC 60751) with electrical connection to 2, 3 or 4 wires
- The sensing elements (Pt100) are available in wire-wound WW (range:-200...600°C) or thin-film TF (range:-50...400°C) with single or double Pt100 execution
- ATEX 1/2 GD EEx-ia certification
- ATEX 2 GD EEx-d certification



Function and system design

Measuring principle

The RTD (Resistance Temperature Detector), is a sensor where the electrical resistance varies with the temperature. The material of the RTD is Platinum (Pt) with a value of the resistance (R), referred to a nominal value at the temperature of **0°C = 100,00 Ω** (in compliance to rule IEC 60751; it is called Pt100). The very important is to define the RTD; it is defined with a standard "α" value measured between 0°C and 100°C.

This value is: $\alpha = 3.85 \times 10^{-3} \text{ } ^\circ\text{C}^{-1}$.

The temperature is measured indirectly by reading the voltage drop across the sensing resistor in the presence of a constant current flowing through it using Ohm's. The measuring current should be as small as possible to minimise possible sensor selfheating; normally this current is around 1mA, no higher.

The resistance value measured for each degree is about = **0,391 Ohm/K**; over 0°C it is opposite proportional at the temperature. The standard RTD connection at the plant instrument can be to 2, 3 or 4 wires to simple or double RTD element.

Equipment architecture

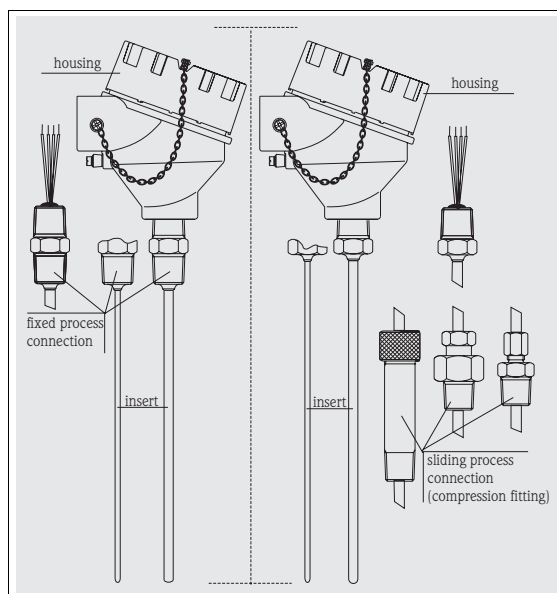

The construction of the TR65 temperature sensor is based on the following standards:

- EN 50014/18 (housing)
- Neck (Fixed or sliding process connection)
- IEC 60751 (insert and sensing element).

The housing is in painted aluminium alloy; it is suitable to contain a transmitter and/or the ceramic block of the insert; the "Ingress Protection" is from IP66 to IP68.

The process connections of the TR65 are: compression fitting (sliding or spring loaded), fixed process connection, threaded (M, GAS or NPT, see the section "System components").

The inserts diameter is 3 - 4,5 - 6 - 8 mm and are composed by MgO cable (SS 316L sheath) with a sensing element (Pt100 ohm/0°C) positioned at the MgO cable tip. The standard electrical connection is to 2, 3 or 4 wires for sensing element (Pt100).

Fig. 1: TR65 with the various types of process connections (fixed or fitting) and parts of the insert.

Material & Weight

Housing	Insert	Process connection	Weight
aluminium epoxy coated	sheath in SS 316L/1.4404	fixed or sliding or spring loaded in SS 316/1.4401	from 0.5 to 1.0 kg for standard options

Performance

Operating conditions

Operating condition or test	Product type or rules		Value or data of test
Ambient temperature	housing (without head-mounted transmitter)		-40 ÷ 130°C
	housing (with head-mounted transmitter)		-40 ÷ 85°C
Process temperature	Sliding (e.g. TA 50) compression fitting	Sleeve in SS	max 400°C
	Fixed process connection: same of measurement range taking care to ambient temperature (fig. 4)		
Maximum Process pressure	(e.g. TA 50) compression fitting	Sleeve in SS	8 MPa (80 bar) at 20°C
	Fixed process connection		
Maximum flow velocity	The highest flow velocity tolerated by the insert diminishes with increasing lengths of the probe exposed to the stream of the fluid.		
Shock and vibration resistance test	RTD insert in according to the rule IEC 60751:	Acceleration	3 g of peak
		Frequency	from 10Hz to 500Hz and back
		Time of the test	10 hours

Accuracy

RTD maximum error type TF - Range: -50 to 400°C		
Cl. A	$3\sigma = 0.15 + 0.0020 t $ $3\sigma = 0.30 + 0.0050 t $	= -50...250°C = +250...400°C
Cl. 1/3 DIN B	$3\sigma = 0.10 + 0.0017 t $ $3\sigma = 0.15 + 0.0020 t $ $3\sigma = 0.15 + 0.0020 t $ $3\sigma = 0.30 + 0.0050 t $	= 0...100°C = -50...0 = 100...250°C = 250...400°C

DIN-IEC-EN 60751

The graph plots Tolerance (°C) on the y-axis (0 to 2.0) against Temperature (°C) on the x-axis (-200 to 600). Three lines represent different accuracy classes: Class B (°C), Class A (°C), and Class 1/3 DIN B (°C). Class B has the highest tolerance, followed by Class A, and Class 1/3 DIN B has the lowest tolerance.

$\pm 3\sigma$ = range including 99.7% of the readings. (|t|= absolute value of the temperature in °C).

RTD maximum error type WW - Range: -200 to 600°C		
Cl. A	$3\sigma = 0.15 + 0.0020 t $	= -200...600°C
Cl. 1/3 DIN B	$3\sigma = 0.10 + 0.0017 t $ $3\sigma = 0.15 + 0.0020 t $ $3\sigma = 0.15 + 0.0020 t $	= -50...250°C = -200...-50 = 250...600°C

DIN-IEC-EN 60751

The graph plots Tolerance (°C) on the y-axis (0 to 2.0) against Temperature (°C) on the x-axis (-200 to 600). Two lines represent different accuracy classes: Class A (°C) and Class 1/3 DIN B (°C). Class A has a higher tolerance than Class 1/3 DIN B.

$\pm 3\sigma$ = range including 99.7% of the readings. (|t|= absolute value of the temperature in °C).

Others errors	
Transmitter maximum error	See the corresponding documentation (codes at the end of the document)
Display maximum error	0.1% FSR + 1 digit (FSR = Full Scale Range)

The “4 wires” configuration, is provided as a standard connection for the single Pt 100’s excludes additional errors in every condition.
 Generally in the “4 wires” configuration there is a higher guarantee of accuracy.

Response time

Tests, with the RTD insert, in water at 0.4 m/s (according to IEC 60751); from 23 to 33°C:

Stem diameter of the insert	Sensing element type	Time for 50% or 90% of temperature step	Response time
6 mm	TF / WW	t ₅₀	3,5 s
		t ₉₀	8,0 s
3 mm	TF / WW	t ₅₀	2,0 s
		t ₉₀	5,0 s

Insulation

Measurement Insulation type	Result
Insulation resistance between terminals and probe sheath	above 100 MΩ at 25°C
According to IEC 60751, test voltage 250 V	above 10 MΩ at 300°C

Self heating

Negligible when the E+H iTEMP® transmitters are employed.

Installation

The Omnigrad S TR65 thermometers can be mounted on pipes, vessels or other plant parts that may be necessary, by means of compression junctions or thermowells.

The absence of the extension neck (situated between the process connection and the head) may expose the housing to overheating. To ensure that the head temperature has not to exceed the limit values defined in paragraph "System components" (refer to fig. 4).

In the case of ATEX certified components (transmitter, insert), please refer to the relevant documentation (refer to the code at the end of this document).

Immersion depth may have an effect on the accuracy of the measurement. If the immersion is too low, an error may be generated in the temperature recorded due to the lower temperature of the process fluid near to the walls and heat transfer, which takes place through the sensor stem.

The incidence of such an error can be not negligible if there is a big difference between the process temperature and the ambient temperature (refer to fig. 2). To avoid measurement errors of this kind, it is advisable to set an immersion length (**L**) of at least 50÷70 mm (without thermowell).

In pipes of a small section the axis line of the duct must be reached and if possible slightly exceeded by the tip of the probe (refer to fig. 2A-2B). Insulation of the outer part of the pipe reduces the effect produced by a low immersion of the sensor. Another solution may be a tilted installation (see fig.2C-2D). For a best installation, in the industries, it's better to follow the rule: $h \approx d$, $L > D/2 + h$.

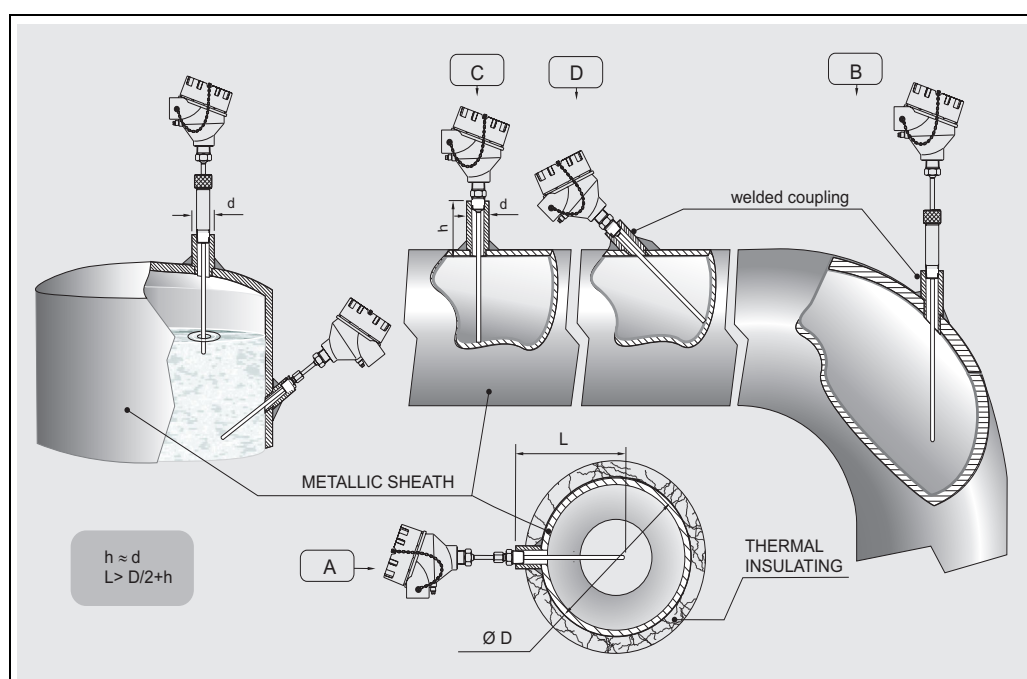

Fig. 2: Installation examples

In the case of two-phase flows, pay special attention to the choice of measurement point, as there may be fluctuations in the value of the detected temperature.

With regard to corrosion, the base material of the wetted parts in contact with the fluid (SS 316L/1.4404, compression fitting in SS 316/1.4401 or SS 316L/1.4404 and several types of sleeves) can tolerate the common corrosive media up to even the highest temperatures. For further information on specific applications, please contact the E+H Customer Service Department.

In the case that the sensor components are disassembled, in the following reassembly procedure the definite torques must be employed.

In the case of vibrations the thin film sensing element (TF) may offer advantages, but the behaviour depends on the intensity, the direction and the dominating frequency in the vibration mode.

The wire wound Pt 100 (WW), besides having a larger measurement and accuracy range, guarantees greater long term stability.

System components

Housing

The protection housing, our "TA21H", commonly referred to the "connection head", is used to contain and protect the terminal block or the transmitter and to join the electric connections to the mechanical component.

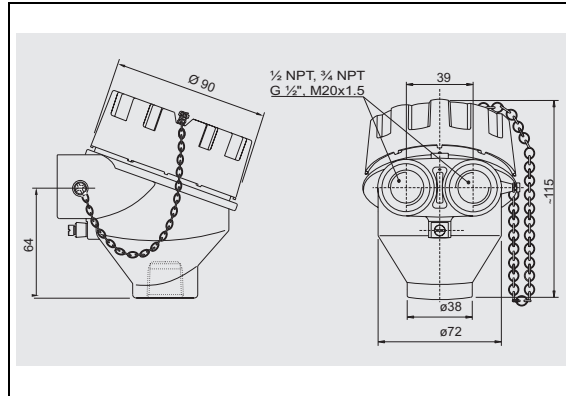

Fig. 3: Housing TA21H

The TA21H used for the TR65 is compliant with EN 50014/18 and EN 50281-1-1, EN 50281-1-2 standards (Ex-d certification for explosion proof type of protection).

The matching of the head with the extension below the head and the cover (threaded) ensures a degree of protection from IP66 to IP68. The head also has a chain to connect the body to the cover, which facilitates the use of the instrument during the maintenance on systems. The single or double threaded electrical cable entry can be: M20x1.5, 1/2" NPT or 3/4" NPT, G1/2".

Extension neck

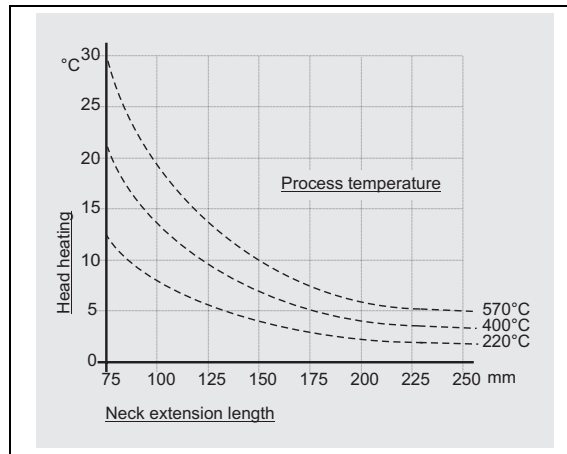

Fig. 4: Heating of the head caused by the process temperature

The extension is inserted between the housing and the thermowell or the plant connection, this part is called neck.

In the TR65 the extension neck, is defined by the fixed, sliding or spring loaded process connection.

As illustrated by the drawing (fig. 4), the length of the extension neck may influence the temperature in the head.

It is necessary that this temperature is kept within the limit values defined in the paragraph "Operating Conditions".

Before choosing the connection, it is better to verify this graphic and therefore to choose a suitable extension to avoid the heating of the head.

Process connection

Standard process connection available in the following types:

Type	Model	Threaded PC	L mm	C mm
A1	Fixed	3/4" NPT	42	15
A2	Fixed	1/2" NPT	42	8
B1	Comp. fitting	1/2" NPT 3/4" NPT	55 55	8 8
B2	Spring loaded	1/2" NPT	55	8
B3	Spring loaded	1/2" NPT 3/4" NPT	105 120	8 8

Electronic head transmitter

The required type of output signal can be obtained by choosing the correct head mounted transmitter. Endress+Hauser supplies “state-of-the-art” transmitters (the iTEMP® series) built in 2-wire technology and with 4...20 mA output signal, HART® or PROFIBUS-PA®. All of the transmitters can be easily programmed using a PC:

Head transmitter	Communication software
PCP TMT181	ReadWin® 2000
HART® TMT182	ReadWin® 2000, FieldCare, Hand held module DXR275, DXR375
PROFIBUS PA® TMT184	FieldCare

In the case of PROFIBUS-PA® transmitters, E+H recommends the use of PROFIBUS® dedicated connectors. The Weidmüller type is provided as a standard option. For detailed information about transmitters, please refer to the relevant documentation (refer to TI codes at the end of the document). If a head-mounted transmitter is not employed, the sensor probe may be connected through the terminal block to a remote converter (i.e. DIN rail transmitter). The customer may specify the configuration desired during the order phase. The head-mounted transmitters available are:

Description	Dwg
TMT180 and TMT181:PCP 4...20 mA. The TMT180 and the TMT181 are PC programmable transmitters. The TMT180 is also available in a version with enhanced accuracy (0.1°C vs. 0.2°C) in the temperature range - 50...250°C and in a version with a fixed measurement range (specified by the customer in the order phase). The TMT182 output consists of 4...20 mA and HART® superimposed signals. TMT182: Smart HART®.	
TMT184: PROFIBUS-PA®. For the TMT184, with PROFIBUS-PA® output signal, the communication address may be set via software or via mechanical dip-switch.	

Probe

On TR65 the measurement probe is constituted by a not replaceable mineral insulated insert (MgO) with a sheath in AISI316L.

The immersion length (ML) is available in the most commonly used dimensions and customized special dimensions. They can be personalized by the client within a range of values (refer to “Sales Structure” at the end of the document).

The length of the sensor can be chosen within a standard range from 50 to 5000 mm.

Sensors with a length above 5000 mm can also be ordered and supplied after a technical analysis of the application (max length 30.000 mm).

Although the wiring diagram of single Pt 100 is always supplied with 4 wires configuration, the connection of a transmitter is executed with 3 wires as well, by avoiding to connect whichever of the terminals (see fig. 5).

The configuration Pt100 double with 2 wires is only available for the ATEX certified inserts.

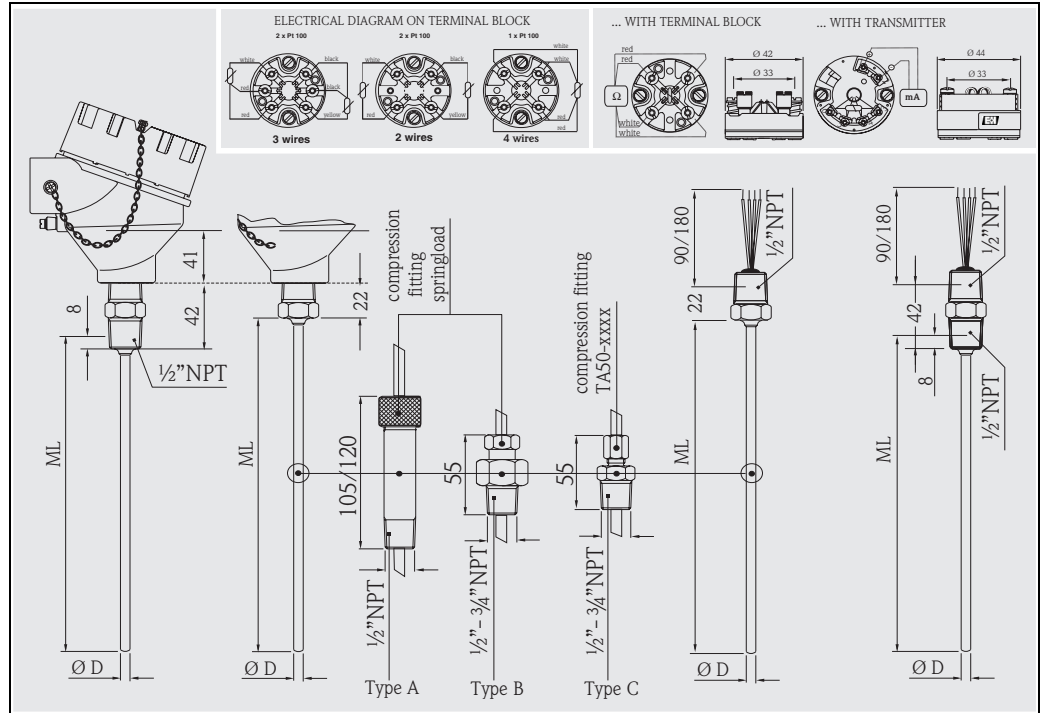

Fig. 5: Functional components and standard electrical diagrams with ceramic terminal block and transmitter.

The use of a TR65 with standard lengths ensures fast delivery times; this allows our customers to reduce the amount of spare parts to be kept on stock.

Certificates & approvals

Ex approval

- ATEX Certificate CESI 05ATEX038 for explosion proof type of protection: ATEX II 2 GD EEx-d IIC T6..T5 T85°...T100°C. The TR65 is **CE** marked.
- ATEX Certificate KEMA 01ATEX1169 X for intrinsically safe type of protection: 1GD or 1/2 GD EEx-ia IIC T6...T1 T85...450°C. The TR65 is **CE** marked.

With regards to the NAMUR NE 24 certificate and the Manufacturer's Declaration according to the standard EN 50018, EN 50020, EN 50281-1-1, EN 50281-1-2, E+H Customer Service will be able to provide further detailed information.

PED approval

The Pressure Equipment Directive (97/23/CE) is respected. As paragraph 2.1 of article 1 is not applicable to these types of instruments. The **CE** mark according to PED Directive is not requested.

Material certification

The material certificate EN 10204 3.1 can be directly selected from the sale structure of the product and refers to the parts of the sensor in contact with the process fluid. Other types of certificates related to materials can be requested separately.

The "short form" certificate includes a simplified declaration with no enclosures of documents related to the materials used in the construction of the single sensor and guarantees the traceability of the materials through the identification number of the thermometer.

The data related to the origin of the materials can subsequently be requested by the client if necessary.

Further details

Maintenance

The Omnigrad S TR65 thermometers do not require any specific maintenance.

In the case of ATEX certified components (transmitter, insert) please refer to the corresponding specific relevant documentation (at the end of the document).

Ordering information

Sales structure

TR65-	Omnigrad S TR65 RTD thermometer Thermometer complete EE-d or EEx-ia certified, without replaceable insert. Housing: IP66 / IP68, material: aluminium epoxy coating. Execution for direct contact with a process connection welded at the insert or sliding on the insert sheath. Operating and measurement ranges: from -50 to 400°C (with TF); -200 to 600°C (with WW)
Approval	
A	Non-hazardous area
C	*ATEX II 1/2 GD EEx ia IIC
E	*ATEX II 2 GD EEx d IIC
Head, material, IP grade	
A	TA21H, Aluminium epoxy coating, , IP66 / IP68
Y	Special version, to be specified
Cable entry	
A	1 x 1/2 NPT
B	2 x 1/2 NPT
C	1 x 3/4 NPT
D	2 x 3/4 NPT
E	1 x M20 x1,5
F	2 x M20 x1,5
Y	Special version, to be specified
Process connection	
AA	Not needed
11	Thread 1/2" NPT - M, SS 316
12	Thread 3/4" NPT - M, SS 316
21	Compression fitting, 1/2" NPT - M, 55 mm, springloaded
31	Compression fitting, 1/2" NPT - M, 105 mm, springloaded
32	Compression fitting, 3/4" NPT - M, 120 mm, springloaded
41	Compression fitting TA50, 1/2" NPT - M, sliding
42	Compression fitting TA50, 3/4" NPT - M, sliding
99	Special version, to be specified
Insertion length ML	
X	... mm
Y	Special version, to be specified
Insert diameter	
1	3.0 mm
3	6.0 mm
9	Special version, to be specified
Tip Shape	
1	Standard
2	Conical to 120°
9	Special version, to be specified
Immersion length L	
X	...mm
Y	Special version, to be specified
Head transmitter; Range	
F	Flying leads
C	Terminal block
2	TMT180-A21 fix; 0.2K, from...to...°C, span limit -200/650°C
3	TMT180-A22 fix; 0.1K, from...to...°C, span limit -50/250°C
4	TMT180-A11 prog.; 0.2K, from...to...°C, span limit -200/650°C
5	TMT180-A12 prog.; 0.1K, from...to...°C, span limit -50/250°C
P	TMT181-A, PCP, from...to...°C, 2-wire, isolated
Q	TMT181-B, PCP ATEX, from...to...°C, 2-wire, isolated
R	TMT182-A, HART, from...to...°C, 2-wire, isolated
T	TMT182-B, HART ATEX, from...to...°C, 2-wire, isolated
S	TMT184-A, Profibus PA, from...to...°C, 2-wire, isolated
V	TMT184-A, Profibus PA ATEX, from...to...°C, 2-wire, isolated
1	TH1 separate item

										RTD Class; Wiring	
										3	1 x Pt100 TF, cl. A, range: -50/400°C; 4-wire
										7	1 x Pt100 TF, cl. 1/3 DIN B, range: -50/400°C; 4-wire
										B	2 x Pt100 WW, cl. A, range: -200/600°C; 3-wire
										C	1 x Pt100 WW, cl. A, range: -200/600°C; 4-wire
										D	2 x Pt100 WW, cl. A, range: -200/600°C; 2-wire
										F	2 x Pt100 WW, cl. 1/3 DIN B, range: -200/600°C; 3-wire
										G	1 x Pt100 WW, cl. 1/3 DIN B, range: -200/600°C; 4-wire
										Y	Special version, to be specified
										Additional options	
										0	Not needed
										Y	Special version, to be specified
TR65-										⇐ Order code (complete)	

Sales structure

THT1	Model and version of the head transmitter	
	A11	TMT180-A11 programmable from...to...°C, accuracy 0.2 K, span limit -200...650°C
	A12	TMT180-A12 programmable from...to...°C, accuracy 0.1 K, span limit -50...250°C
	A13	TMT180-A21AA fixed range, accuracy 0.2 K, span 0...50°C
	A14	TMT180-A21AB fixed range, accuracy 0.2 K, span 0...100°C
	A15	TMT180-A21AC fixed range, accuracy 0.2 K, span 0...150°C
	A16	TMT180-A21AD fixed range, accuracy 0.2 K, span 0...250°C
	A17	TMT180-A22AA fixed range, accuracy 0.1 K, span 0...50°C
	A18	TMT180-A22AB fixed range, accuracy 0.1 K, span 0...100°C
	A19	TMT180-A22AC fixed range, accuracy 0.1 K, span 0...150°C
	A20	TMT180-A22AD fixed range, accuracy 0.1 K, span 0...250°C
	A21	TMT180-A21 fixed range, accuracy 0.2 K, span limit -200...650°C, from...to...°C
	A22	TMT180-A22 fixed range, accuracy 0.1 K, span limit -50...250°C, from...to...°C
	F11	TMT181-A PCP, 2-wire, isolated, programmable from...to...°C
	F21	TMT181-B PCP ATEX, 2-wire, isolated, programmable from...to...°C
	F22	TMT181-C PCP FM IS, 2-wire, isolated, programmable from...to...°C
	F23	TMT181-D PCP CSA, 2-wire, isolated, programmable from...to...°C
	F24	TMT181-E PCP ATEX II3D, 2-wire, isolated, programmable from...to...°C
	F25	TMT181-F PCP ATEX II3D, 2-wire, isolated, programmable from...to...°C
	L11	TMT182-A HART®, 2-wire, isolated, programmable from...to...°C
	L21	TMT182-B HART® ATEX, 2-wire, isolated, programmable from...to...°C
	L22	TMT182-C HART® FM IS, 2-wire, isolated, programmable from...to...°C
	L23	TMT182-D HART® CSA, 2-wire, isolated, programmable from...to...°C
	L24	TMT182-E HART® ATEX II3D, 2-wire, isolated, programmable from...to...°C
	L25	TMT182-F HART® ATEX II3D, 2-wire, isolated, programmable from...to...°C
	K11	TMT184-A PROFIBUS-PA®, 2-wire, programmable from...to...°C
	K21	TMT184-B PROFIBUS-PA® ATEX, 2-wire, programmable from...to...°C
	K22	TMT184-C PROFIBUS-PA® FM IS, 2-wire, programmable from...to...°C
	K23	TMT184-D PROFIBUS-PA® CSA, 2-wire, programmable from...to...°C
	K24	TMT184-E PROFIBUS-PA® CSA, 2-wire, programmable from...to...°C
	K25	TMT184-F PROFIBUS-PA® ATEX II3D, 2-wire, isolated, programmable from...to...°C
	YYY	Special transmitter
Application and services		
	1	Assembled into position
	9	Special version
THT1-		⇐ Order code (complete)

Supplementary documentation

<input type="checkbox"/> Brochure Field of activities - Temperature measurement	FA006T/09/en
<input type="checkbox"/> Temperature head transmitter iTEMP® PT -TMT180	TI 088R/09/en
<input type="checkbox"/> Temperature head transmitter iTEMP® PCP -TMT181	TI 070R/09/en
<input type="checkbox"/> Temperature head transmitter iTEMP® HART® -TMT182	TI 078R/09/en
<input type="checkbox"/> Temperature head transmitter iTEMP® PROFIBUS-PA® -TMT184	TI 079R/09/en
<input type="checkbox"/> TA fittings & sockets Omnigrad TA50, TA55, TA60, TA70, TA75	TI 091T/02/en
<input type="checkbox"/> RTD insert for temperature sensors - Omniset TPR 100	TI 268T/02/en
<input type="checkbox"/> RTD insert for temperature sensors - Omniset TPR 300	TI 290T/02/en
<input type="checkbox"/> Safety instructions for use in hazardous areas (TPR 100)	XA 003T/02/z1
<input type="checkbox"/> Industrial thermometers, RTD and thermocouples	TI 236T/02/en
<input type="checkbox"/> Safety instructions for use in hazardous areas (TPR 300 to be released)	XA 015T/02/z1

International Head Quarter

Endress+Hauser
GmbH+Co. KG
Instruments International
Colmarer Str. 6
79576 Weil am Rhein
Germany

Tel. +49 76 21 9 75 02
Fax +49 76 21 9 75 34 5
www.endress.com
info@ii.endress.com

Endress+Hauser 

People for Process Automation