

# Technical Information

## iTHERM

### MultiSens Bundle TMS31

Metallic flexible rope multipoint for silos and storage tank applications



#### Application

- Oil storage tanks
- Bulk material silos

#### Your benefits

- Easy installation and process integration thanks to a high degree of customization
- Flexible rope that adapts to different silos or tank operating conditions (filling, emptying, storage, ...)
- Intrinsically safe components for use in Ex areas
- Highly robust design for a long product lifetime and continuous monitoring in all conditions

## Table of contents

<b>Function and system design</b> . . . . .	<b>3</b>	Material certification . . . . .	21
Measuring principle . . . . .	3	Test report and calibration . . . . .	21
Measuring system . . . . .	3		
Equipment architecture . . . . .	4	<b>Ordering information</b> . . . . .	<b>22</b>
<b>Input</b> . . . . .	<b>6</b>	<b>Accessories</b> . . . . .	<b>25</b>
Measured variable . . . . .	6	Device-specific accessories . . . . .	25
Measuring range . . . . .	6	Communication-specific accessories . . . . .	26
<b>Output</b> . . . . .	<b>6</b>	Service-specific accessories . . . . .	26
Output signal . . . . .	6	<b>Documentation</b> . . . . .	<b>27</b>
Family of temperature transmitters . . . . .	7		
<b>Power supply</b> . . . . .	<b>7</b>		
Wiring diagrams . . . . .	7		
<b>Performance characteristics</b> . . . . .	<b>10</b>		
Accuracy . . . . .	10		
Influence of ambient temperature . . . . .	11		
Response time . . . . .	11		
Shock and vibration resistance . . . . .	11		
Calibration . . . . .	11		
<b>Installation</b> . . . . .	<b>12</b>		
Mounting location . . . . .	12		
Orientation . . . . .	12		
Installation instructions . . . . .	12		
<b>Environment</b> . . . . .	<b>13</b>		
Ambient temperature range . . . . .	13		
Storage temperature . . . . .	13		
Humidity . . . . .	13		
Climate class . . . . .	14		
Degree of protection . . . . .	14		
Electromagnetic compatibility (EMC) . . . . .	14		
<b>Process</b> . . . . .	<b>14</b>		
Process temperature range . . . . .	14		
Process pressure range . . . . .	14		
<b>Mechanical construction</b> . . . . .	<b>14</b>		
Design, dimensions . . . . .	14		
Weight . . . . .	19		
Materials . . . . .	19		
Process connection . . . . .	20		
<b>Operability</b> . . . . .	<b>20</b>		
<b>Certificates and approvals</b> . . . . .	<b>21</b>		
CE Mark . . . . .	21		
Hazardous area approvals . . . . .	21		
Certification HART . . . . .	21		
Certification FOUNDATION Fieldbus . . . . .	21		
Certification PROFIBUS® PA . . . . .	21		
Other standards and guidelines . . . . .	21		

## Function and system design

### Measuring principle

#### Thermocouples (TC)

Thermocouples are comparatively simple, robust temperature sensors which use the Seebeck effect for temperature measurement: if two electrical conductors made of different materials are connected at a point, a weak electrical voltage can be measured between the two open conductor ends if the conductors are subjected to a thermal gradient. This voltage is called thermoelectric voltage or electromotive force (emf.). Its magnitude depends on the type of conducting materials and the temperature difference between the "measuring point" (the junction of the two conductors) and the "cold junction" (the open conductor ends). Accordingly, thermocouples primarily only measure differences in temperature. The absolute temperature at the measuring point can be determined from these if the associated temperature at the cold junction is known or is measured separately and compensated for. The material combinations and associated thermoelectric voltage/temperature characteristics of the most common types of thermocouple are standardized in the IEC 60584 and ASTM E230/ANSI MC96.1 standards.

#### Resistance thermometer (RTD)

These resistance thermometers use a Pt100 temperature sensor according to IEC 60751. The temperature sensor is a temperature-sensitive platinum resistor with a resistance of 100  $\Omega$  at 0 °C (32 °F) and a temperature coefficient  $\alpha = 0.003851$  °C<sup>-1</sup>.

There are generally two different kinds of platinum resistance thermometers:

- **Wire wound (WW):** Here, a double coil of fine, high-purity platinum wire is located in a ceramic support. This is then sealed top and bottom with a ceramic protective layer. Such resistance thermometers not only facilitate very reproducible measurements but also offer good long-term stability of the resistance/temperature characteristic within temperature ranges up to 600 °C (1 112 °F). This type of sensor is relatively large in size and it is comparatively sensitive to vibrations.
- **Thin film platinum resistance thermometers (TF):** A very thin, ultrapure platinum layer, approx. 1  $\mu\text{m}$  thick, is vaporized in a vacuum on a ceramic substrate and then structured photolithographically. The platinum conductor paths formed in this way create the measuring resistance. Additional covering and passivation layers are applied and reliably protect the thin platinum layer from contamination and oxidation, even at high temperatures. The primary advantages of thin film temperature sensors over wire wound versions are their smaller sizes and better vibration resistance. A relatively low principle-based deviation of the resistance/temperature characteristic from the standard characteristic of IEC 60751 can frequently be observed among TF sensors at high temperatures. As a result, the tight limit values of tolerance category A as per IEC 60751 can only be observed with TF sensors at temperatures up to approx. 300 °C (572 °F). For this reason, thin-film sensors are generally only used for temperature measurements in ranges below 400 °C (752 °F).

### Measuring system

Endress+Hauser offers a complete portfolio of optimized components for the temperature measuring point – everything you need for the seamless integration of the measuring point into the overall facility.

This includes:

- Power supply unit/active barrier
- Configuration units
- Overvoltage protection



For more information, see the brochure 'System Components - Solutions for a Complete Measuring Point' (FA00016K/09)

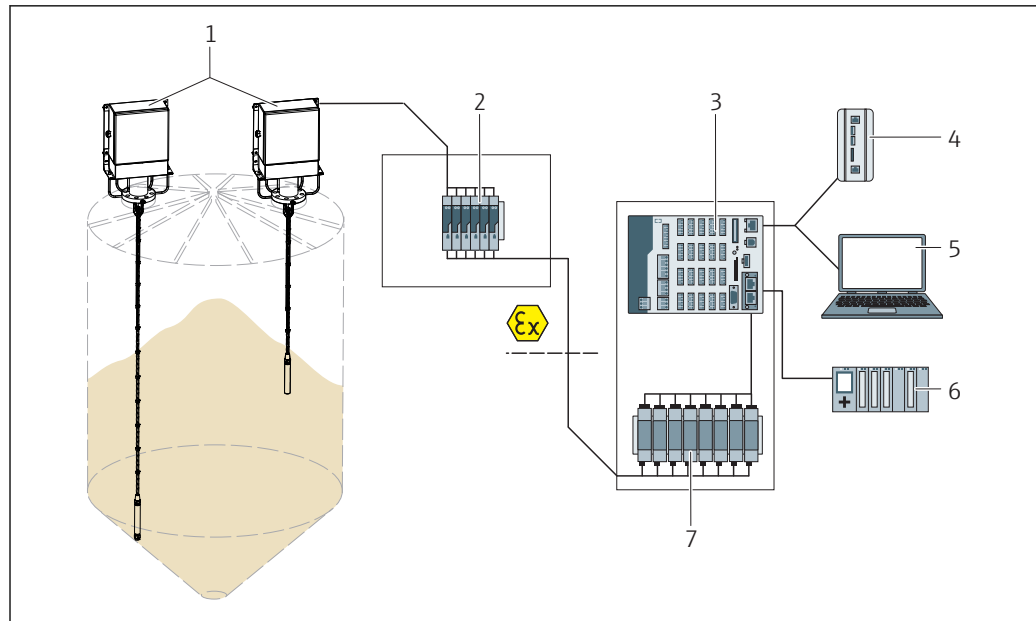

A0038295

1 Application example in a silo.

- 1 Mounted multipoint thermometer, optionally with built-in transmitters in the junction box for 4 to 20 mA-, HART-, PROFIBUS® PA-, FOUNDATION Fieldbus™ communication or terminal blocks for remote wiring.
- 2 TMT82 or other Ex approved transmitters
- 3 RSG45 with data recording, calculation, logic control, limit monitoring, alarms and events
- 4 Edge device
- 5 Device configuration with application software FieldCare
- 6 Fieldbus to DCS/PLC
- 7 Active barrier RN221N (24 V<sub>DC</sub>, 30 mA) that has a galvanically isolated output for supplying voltage to loop-powered transmitters. The universal power supply works with an input supply voltage of 20 to 250 V DC/AC; 50/60 Hz, which means that it can be used in all international power grids.

## Equipment architecture

The multipoint thermometer belongs to a range of modular product configuration for multipoint temperature detection with a design where subassemblies and components can be managed individually for easy maintenance and spare part ordering.

The temperature probe-only version consists of many sub-assemblies:

- Insert
- Rope
- Weight
- Process connection
- Neck (see below for a more detailed description)

In general the instrument measures the temperature profile inside the process environment by means of many sensors wrapped around a rope, jointed to a suitable process connection which ensures the right tightness level.

The temperature probe + diagnostic version combines the temperature probe with a head transmitter, which is available with enhanced accuracy and reliability compared to directly wired sensors. Output communication protocols available are: Analog output 4 to 20 mA, HART®,

PROFIBUS® PA, FOUNDATION Fieldbus™. Externally the extension cables are wired into the junction box, which can be directly mounted or remotely as an option.

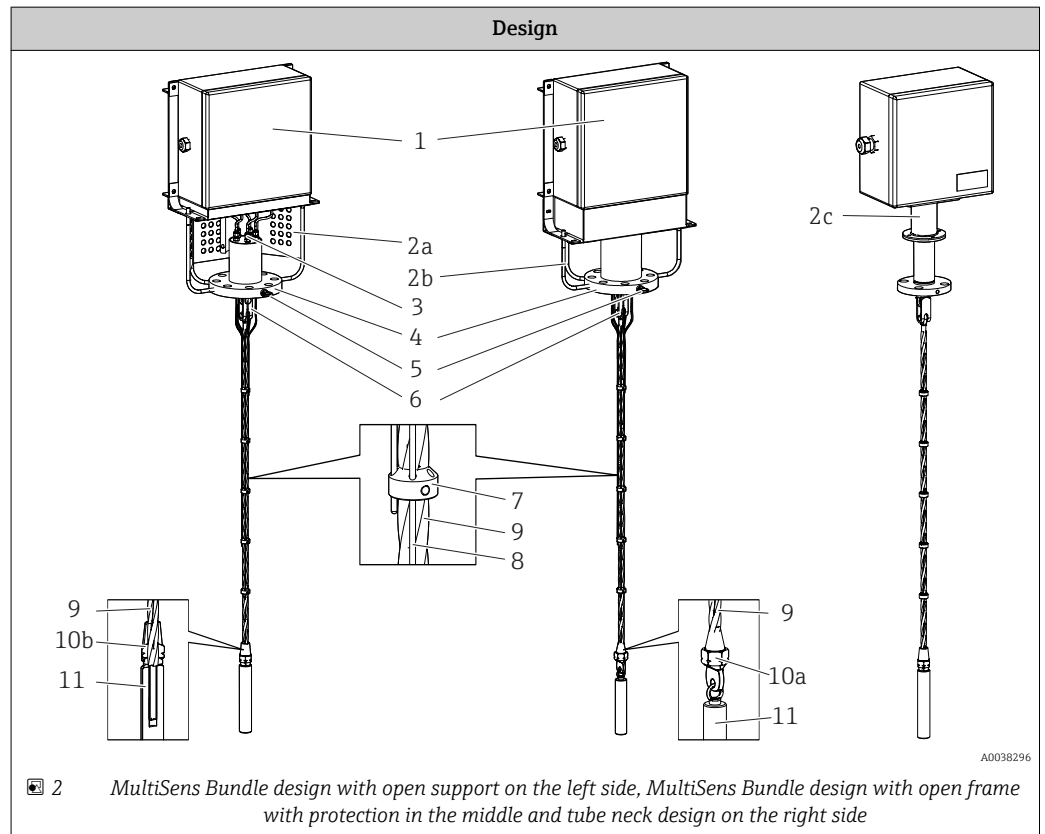

Description and available options	
1: Head	Hinged cover junction box for electrical connections. It includes components such as electrical terminals, transmitters and cable glandes. <ul style="list-style-type: none"> <li>■ 316/316L</li> <li>■ Other materials on request</li> </ul>
2a: Open supporting frame	Modular frame support that is adjustable for all available junction boxes. 316/316L
2b: Supporting frame with cover	Modular support that is adjustable for all available junction boxes and ensures extension cable inspection. 316/316L
2c: Tube neck	Modular tube frame support adjustable for all available junction boxes 316/316L
3: Compression fitting	High reliability for tightness between process and external environment, for a wide range of process fluids concentration and severe combination between temperature and pressure. <ul style="list-style-type: none"> <li>■ 316L</li> <li>■ 316H</li> </ul>
4: Process connection	Represented by a flange according to international standards, or engineered to satisfy specific process requirements. → 20
5: Eyebolt	Lifting device for easy handling during installation phase. 316
6: Toggle joint	Connection between the rope and the process connection. 316

Description and available options	
7: Ogives	Insert guide for the correct positioning of the measuring sensing element. <ul style="list-style-type: none"> <li>▪ 316</li> <li>▪ 316L</li> </ul>
8: Insert	Thermocouple (type J, K) grounded and ungrounded execution or RTD (Pt100 wire wound).
9: Rope	Metallic rope. 316
10a: Swage eye	Ring-bolt end connection. 316
10b: Metric swage thread	Threaded end connection. 316
11: Weight	Weight to maintain the rope pretensioned and in a straight position during working condition (i.e. tank filling). <ul style="list-style-type: none"> <li>▪ 316</li> <li>▪ 316L</li> </ul>

## Input

**Measured variable** Temperature (temperature linear transmission behavior)

**Measuring range** RTD:

Input	Designation	Measuring range limits
RTD as per IEC 60751	Pt100	-200 to +600 °C (-328 to +1 112 °F)

Thermocouple:

Input	Designation	Measuring range limits
Thermocouples (TC) as per IEC 60584, part 1 - using an Endress+Hauser - iTEMP temperature head transmitter	Type J (Fe-CuNi)	-40 to +520 °C (-40 to +968 °F)
	Type K (NiCr-Ni)	-40 to +800 °C (-40 to +1 472 °F)
	Internal cold junction (Pt100) Cold junction accuracy: ± 1 K Max. sensor resistance: 10 kΩ	
Thermocouples (TC) - flying leads - as per IEC 60584 and ASTM E230	Type J (Fe-CuNi)	-210 to +520 °C (-346 to +968 °F), typical sensitivity above 0 °C ≈ 55 µV/K
	Type K (NiCr-Ni)	-270 to +800 °C (-454 to +1 472 °F) <sup>1)</sup> , typical sensitivity above 0 °C ≈ 40 µV/K

1) Limited by jacket material of insert

## Output

**Output signal**

Generally, the measured value can be transmitted in one of two ways:

- Directly-wired sensors - sensor measured values forwarded without a transmitter.
- Via all common protocols by selecting an appropriate Endress+Hauser iTEMP temperature transmitter. All the transmitters listed below are mounted directly in the junction box and wired with the sensory mechanism.

**Family of temperature transmitters**

Thermometers fitted with iTEMP transmitters are an installation-ready complete solution to improve temperature measurement by significantly increasing accuracy and reliability, when compared to direct wired sensors, as well as reducing both wiring and maintenance costs.

**PC programmable head transmitters**

They offer a high degree of flexibility, thereby supporting universal application with low inventory storage. The iTEMP transmitters can be configured quickly and easily at a PC. Endress+Hauser offers free configuration software which can be downloaded from the Endress+Hauser Website. More information can be found in the Technical Information.

**HART® programmable head transmitters**

The transmitter is a 2-wire device with one or two measuring inputs and one analog output. The device not only transfers converted signals from resistance thermometers and thermocouples, it also transfers resistance and voltage signals using HART® communication. It can be installed as an intrinsically safe apparatus in Zone 1 hazardous areas and is used for instrumentation in the terminal head (flat face) as per DIN EN 50446. Swift and easy operation, visualization and maintenance by PC using operating software, Simatic PDM or AMS. For more information, see the Technical Information.

**PROFIBUS® PA head transmitters**

Universally programmable head transmitter with PROFIBUS® PA communication. Conversion of various input signals into digital output signals. High accuracy over the complete ambient temperature range. Swift and easy operation, visualization and maintenance using a PC directly from the control panel, e. g. using operating software, Simatic PDM or AMS. For more information, see the Technical Information.

**FOUNDATION Fieldbus™ head transmitters**

Universally programmable head transmitter with FOUNDATION Fieldbus™ communication. Conversion of various input signals into digital output signals. High accuracy over the complete ambient temperature range. Swift and easy operation, visualization and maintenance using a PC directly from the control panel, e.g. using operating software such as ControlCare from Endress +Hauser or NI Configurator from National Instruments. For more information, see the Technical Information.

Advantages of the iTEMP transmitters:

- Dual or single sensor input (optionally for certain transmitters)
- Unsurpassed reliability, accuracy and long-term stability in critical processes
- Mathematical functions
- Monitoring of the thermometer drift, sensor backup functionality, sensor diagnostic functions
- Sensor-transmitter matching for dual sensor input transmitter, based on Callendar/Van Dusen coefficients

## Power supply

-  Electrical connecting cables must be smooth, corrosion resistant, easy to be cleaned and inspected, robust against mechanical stresses, no-humidity sensitivity.
- Grounding or shielding connections are possible via ground terminals on the junction box.

---

**Wiring diagrams**

Wiring diagrams for TC and RTD connection

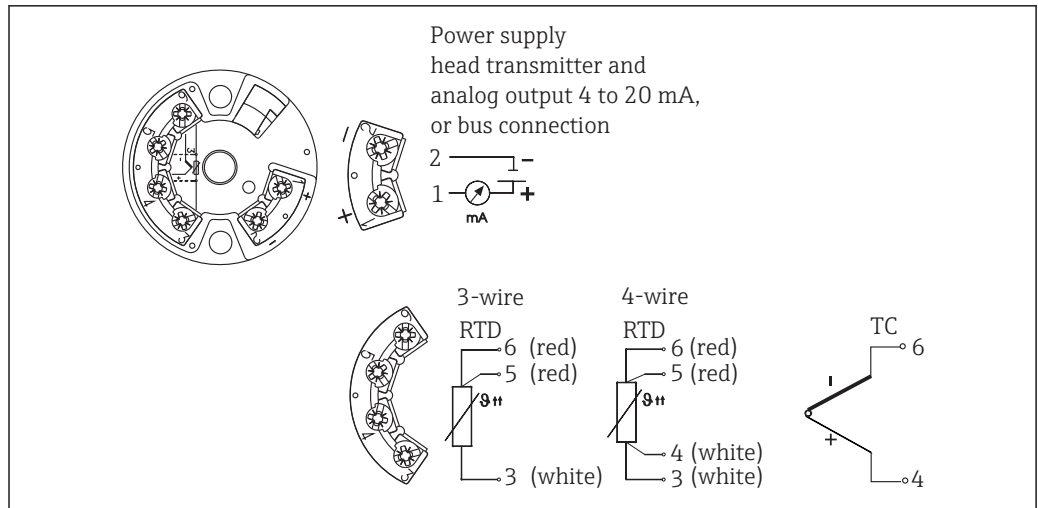

A0016712-EN

3 Wiring diagram of the single sensor input head transmitters (TMT18x)

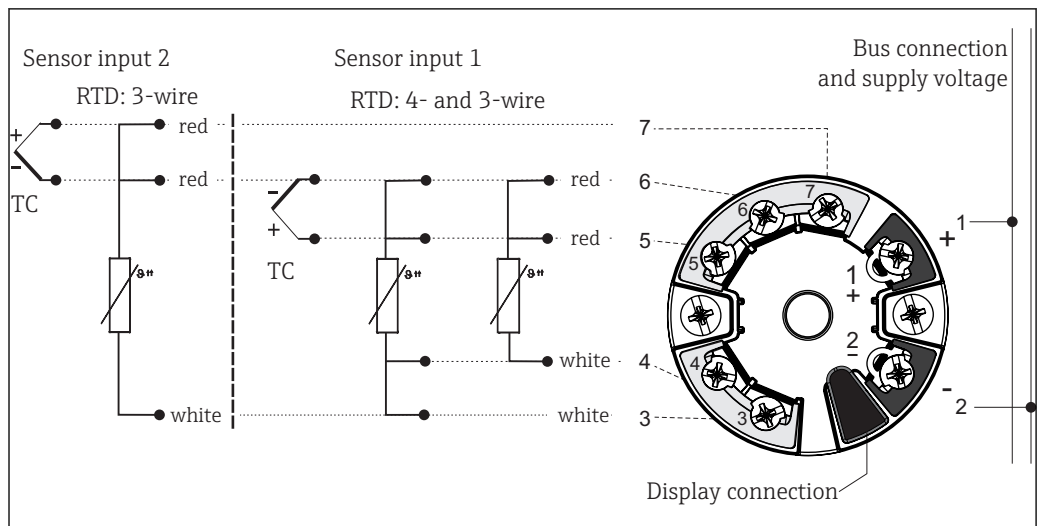

A0016711-EN

4 Wiring diagram of the dual sensor input head transmitters (TMT8x)



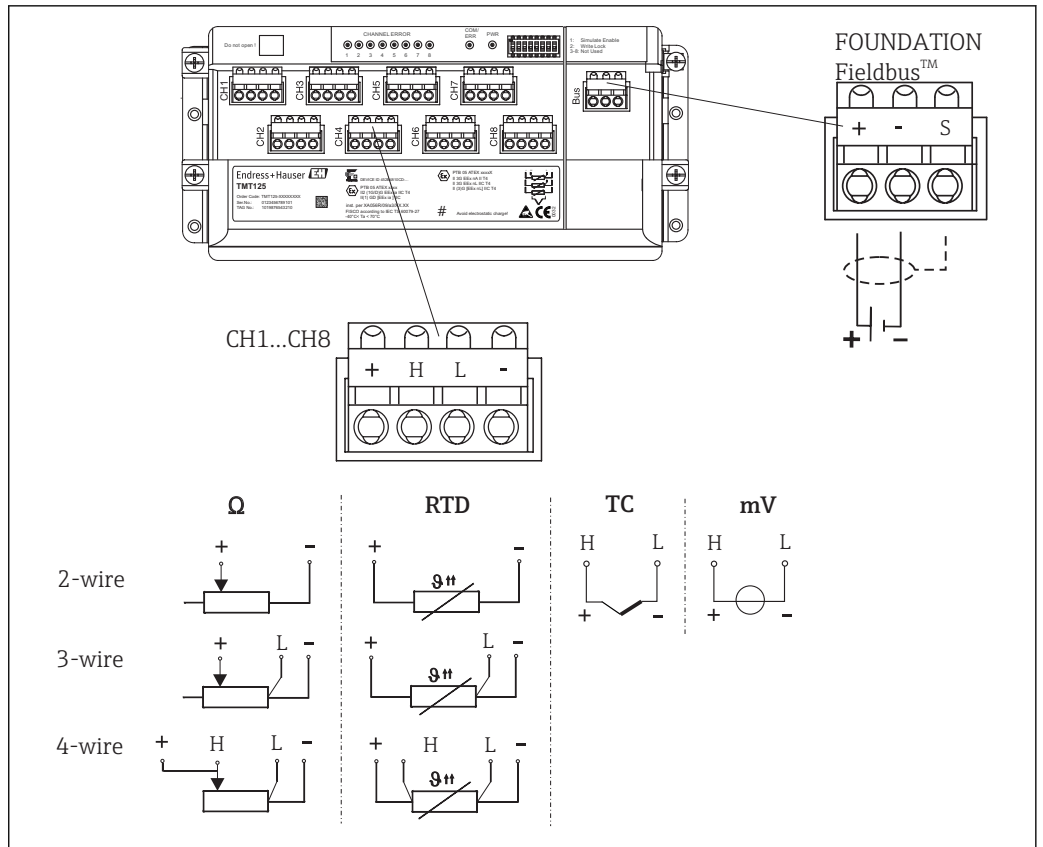

A0006330-EN

5 Wiring diagram of multi-channel transmitter

## Performance characteristics

Accuracy RTD resistance thermometer as per IEC 60751

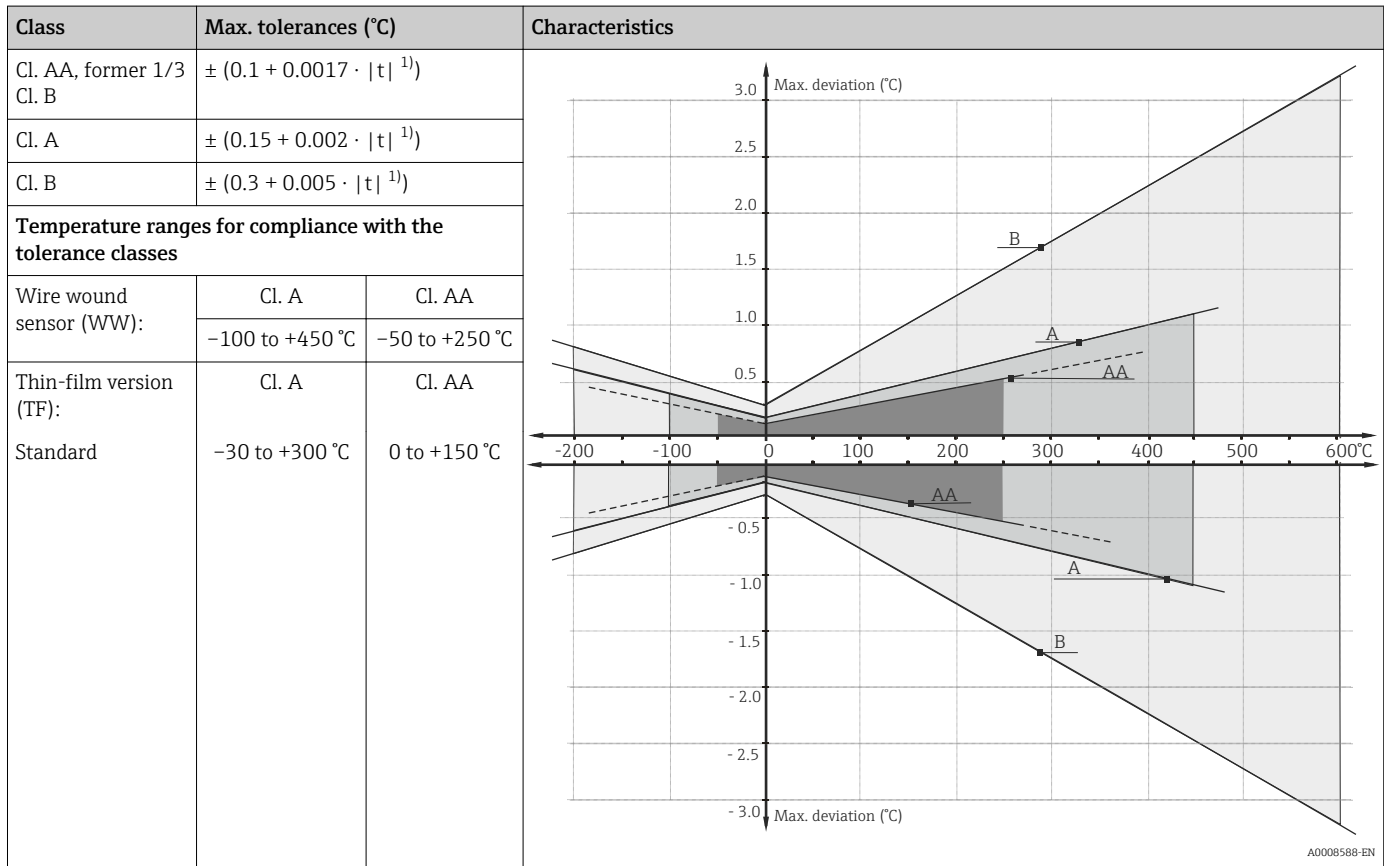

1) |t| = absolute value °C

**i** In order to obtain the maximum tolerances in °F, the results in °C must be multiplied by a factor of 1.8.

Permissible deviation limits of thermoelectric voltages from the standard characteristic for thermocouples as per IEC 60584 or ASTM E230/ANSI MC96.1:

Standard	Type	Standard tolerance		Special tolerance	
		Class	Deviation	Class	Deviation
IEC 60584	J (Fe-CuNi)	2	$\pm 2.5 \text{ °C}$ (-40 to 333 °C) $\pm 0.0075  t ^{1}$ (333 to 750 °C)	1	$\pm 1.5 \text{ °C}$ (-40 to 375 °C) $\pm 0.004  t ^{1}$ (375 to 750 °C)
	K (NiCr-NiAl)	2	$\pm 2.5 \text{ °C}$ (-40 to 333 °C) $\pm 0.0075  t ^{1}$ (333 to 1200 °C)	1	$\pm 1.5 \text{ °C}$ (-40 to 375 °C) $\pm 0.004  t ^{1}$ (375 to 1000 °C)

1) |t| = absolute value °C

Standard	Type	Standard tolerance	Special tolerance
ASTM E230/ANSI MC96.1		Deviation, the larger respective value applies	
	J (Fe-CuNi)	$\pm 2.2 \text{ K}$ or $\pm 0.0075  t ^{1}$ (0 to 760 °C)	$\pm 1.1 \text{ K}$ or $\pm 0.004  t ^{1}$ (0 to 760 °C)
	K (NiCr-NiAl)	$\pm 2.2 \text{ K}$ or $\pm 0.02  t ^{1}$ (-200 to 0 °C) $\pm 2.2 \text{ K}$ or $\pm 0.0075  t ^{1}$ (0 to 1260 °C)	$\pm 1.1 \text{ K}$ or $\pm 0.004  t ^{1}$ (0 to 1260 °C)

1) |t| = absolute value °C

**Influence of ambient temperature**

Depends on the head transmitter used. For details, see the Technical Information.

**Response time**



Response time for the sensor assembly without transmitter. It refers to inserts in direct contact with process.

**RTD**

Calculated at an ambient temperature of approx. 23 °C by immersing the insert in running water (0.4 m/s flow rate, 10 K excess temperature):

Insert diameter	Response time	
Mineral-insulated cable, 3 mm (0.12 in)	t <sub>50</sub>	2 s
	t <sub>90</sub>	5 s
RTD insert StrongSens, 6 mm (1/4 in)	t <sub>50</sub>	< 3.5 s
	t <sub>90</sub>	< 10 s

**Thermocouple (TC)**

Calculated at an ambient temperature of approx. 23 °C by immersing the insert in running water (0.4 m/s flow rate, 10 K excess temperature):

Insert diameter	Response time	
Grounded thermocouple: 3 mm (0.12 in), 2 mm (0.08 in)	t <sub>50</sub>	0.8 s
	t <sub>90</sub>	2 s
Ungrounded thermocouple: 3 mm (0.12 in), 2 mm (0.08 in)	t <sub>50</sub>	1 s
	t <sub>90</sub>	2.5 s

**Shock and vibration resistance**

- RTD: 3G / 10 to 500 Hz according to IEC 60751
- RTD iTHERM StrongSens Pt100 (TF, vibration resistant): Up to 60G
- TC: 4G / 2 to 150 Hz according to IEC 60068-2-6

**Calibration**

Calibration is a service that can be performed on each individual insert, either in order phase, or after multipoint installation.



When calibration shall be performed once the multipoint is installed, please contact the Endress+Hauser service to get full support. Together with the Endress +Hauser service any further activity can be organised to achieve the calibration of the target sensor. In any case it is forbidden to unscrew any threaded component on the process connection under operating conditions = running process.

Calibration involves comparing the measured values of the sensing elements of the multipoint inserts (DUT device under test) with those of a more precise calibration standard using a defined and reproducible measurement method. The aim is to determine the deviation of the DUT measured values from the true value of the measured variable.

Two different methods are used for the inserts:

- Calibration at fixed-point temperatures, e.g. at the freezing point of water at 0 °C (32 °F).
- Calibration compared against a precise reference thermometer.



**Evaluation of inserts**

If a calibration with an acceptable uncertainty of measurement and transferable measurement results is not possible, Endress+Hauser offers an insert evaluation measurement service, if technically feasible.

## Installation

### Mounting location

The installation location must meet the requirements listed in this documentation, such as ambient temperature, protection classification, climatic class, etc.. Care should be taken when checking the sizes of possible existing support frames or brackets welded on the wall of the storage tank or of any other existing frame in the installation area.

### Orientation

The rope multipoint thermometer can be installed in vertical position. The rooftop of the storage tank or silo can be either horizontal or oblique, the rope-joint will automatically adjust its inclination to keep the rope always straight in vertical position.

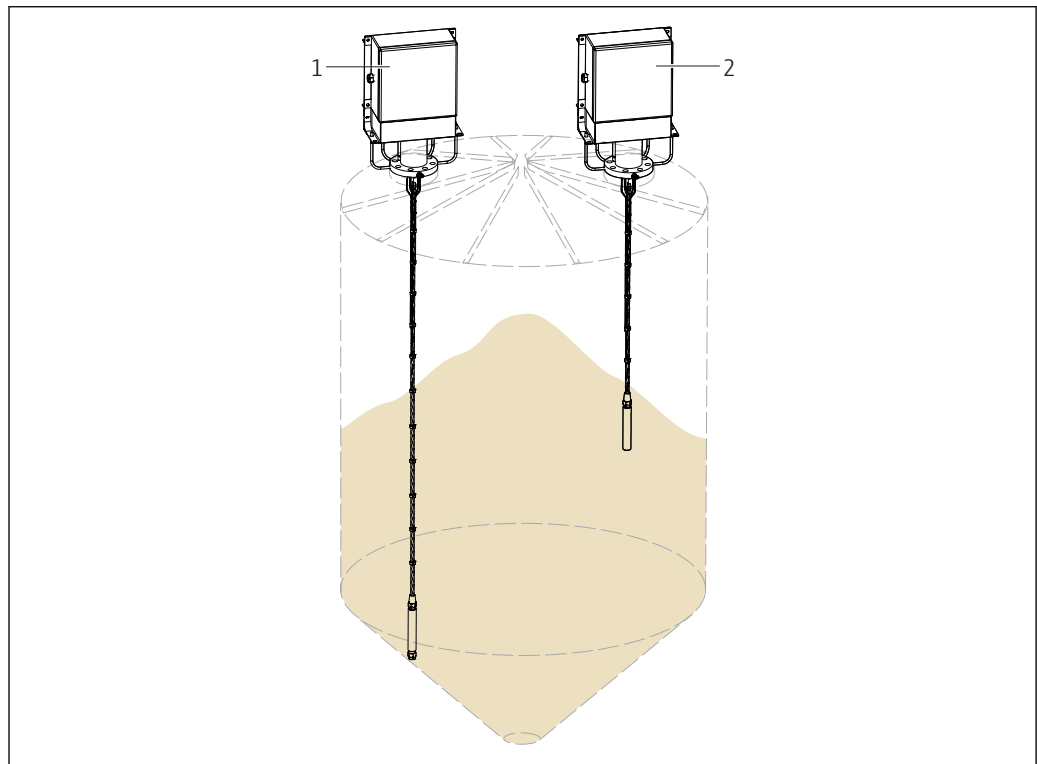

A0038297

#### 6 Installation examples

- 1 TMS 31 hooked to anchored to the bottom
- 2 TMS 31 with free hanging weight

### Installation instructions

The rope multipoint thermometer is designed to be installed with a flanged process connection into a storage tank, silo or similar environment. All parts and components have to be handled with care. During the installation phase, lifting and inserting the device through the preset nozzle, the following must be avoided:

- Misalignment with the nozzle axis.
- Any load on the welded or threaded parts due to the action of the weight of the device.
- Deformation or crushing of the threaded components, bolts, nuts, cable glands and compression fittings.
- Friction between the temperature probes and the internals of the storage tank.
- Avoid any excessive twisting of the rope around its axis which may cause damage to the rope or to the temperature probes.

Ensure that:

- In case of hanging weight design, the same is not touching the bottom of the storage tank.
- In case of swage eye design, the rope is correctly tensioned thanks to proper hooks or similar systems (end users responsibility).

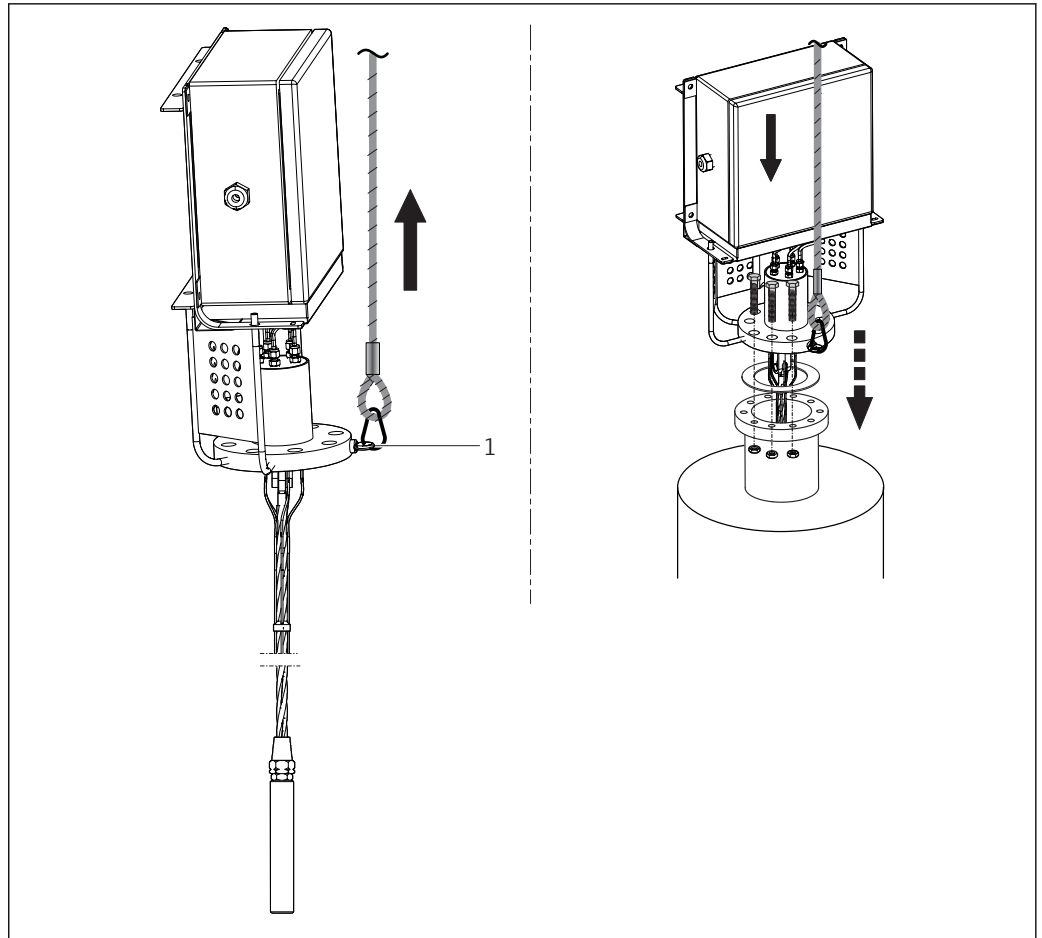

7 Multipoint thermometer installation in a storage tank nozzle via flange process connection.

**i** During installation the whole thermometer must only be lifted and moved by using ropes and the eyebolt of the flange (1) in order to keep the device as straight as possible.

## Environment

Ambient temperature range	Junction box	Non-hazardous area	Hazardous area
	Without mounted transmitter	-50 to +85 °C (-58 to +185 °F)	-50 to +60 °C (-58 to +140 °F)
With mounted head transmitter	-40 to +85 °C (-40 to +185 °F)	-40 to +85 °C (-40 to +185 °F)	Depends on the respective hazardous area approval. Details see Ex documentation.
With mounted multi-channel transmitter	-40 to +85 °C (-40 to +185 °F)	-40 to +85 °C (-40 to +185 °F)	-40 to +70 °C (-40 to +158 °F)

Storage temperature	Junction box	
	With head transmitter	-50 to +95 °C (-58 to +203 °F)
With multi-channel transmitter	-40 to +80 °C (-40 to +176 °F)	-40 to +80 °C (-40 to +176 °F)
With DIN rail transmitter	-40 to +95 °C (-40 to +203 °F)	-40 to +95 °C (-40 to +203 °F)

**Humidity** Condensation according to IEC 60068-2-33:

- Head transmitter: Permitted
- DIN rail transmitter: Not permitted

Maximum relative humidity: 95% according to IEC 60068-2-30

<b>Climate class</b>	Determined when the following components are installed into the junction box: <ul style="list-style-type: none"> <li>▪ Head transmitter: Class C1 according to EN 60654-1</li> <li>▪ Multi-channel transmitter: Tested as per IEC 60068-2-30, meets the requirements regarding class C1-C3 in accordance with IEC 60721-4-3</li> <li>▪ Terminal blocks: Class B2 according to EN 60654-1</li> </ul>
<b>Degree of protection</b>	<ul style="list-style-type: none"> <li>▪ Specification for conduit: IP68</li> <li>▪ Specification for the junction box: IP66/67</li> </ul>
<b>Electromagnetic compatibility (EMC)</b>	Depending on the head transmitter used. For detailed information see the related Technical Information, listed at the end of this document.

## Process

### Agriculture:

The loading and unloading forces and the connection to the tank or silo are the minimum input parameters for the selection of the right product configuration. If special design is requested, additional data such as type of stored material, geometry of the container and type of connection have to be considered as mandatory for the whole product definition.

### Petrolchemical, Oil & Gas:

The process temperature and process pressure are the minimum input parameters for the selection of the right product configuration. If special product features are requested, additional data such as process fluid type, phases, concentration, viscosity, stream and turbulences, corrosion rate have to be considered as mandatory for the whole product definition.

<b>Process temperature range</b>	-10 to +100 °C (+14 to +212 °F).
----------------------------------	----------------------------------

<b>Process pressure range</b>	Up to 40 bar (580.1 psi)
-------------------------------	--------------------------

 Anyhow, the maximum required process pressure has to be combined with the maximum design process temperature. Process connections like compression fittings and flanges with their specific ratings define the maximum operating conditions. Endress+Hauser experts can support the customer on any related questions.

Process application examples:

- Storage of Hydrocarbons
- LPG/LNG
- Liquid Nitrogen
- Organic bulk material storage (cereals, crop, ...)
- Grain silos
- Bulk liquid storage tank
- Beverage processing

## Mechanical construction

<b>Design, dimensions</b>	The overall rope assembly is made of different parts. The rope joint ensures sufficient degree of freedom to the rope system allowing movements during filling and emptying operations. This guarantees low stresses (no extra tensioning) on the rope due to possible lateral force acting on it, therefore a lateral sag of 30cm per 10m rope length is recommended. The transition between the inserts and the extension cable is obtained by the usage of compression fittings, ensuring the declared IP degree protection.
---------------------------	---

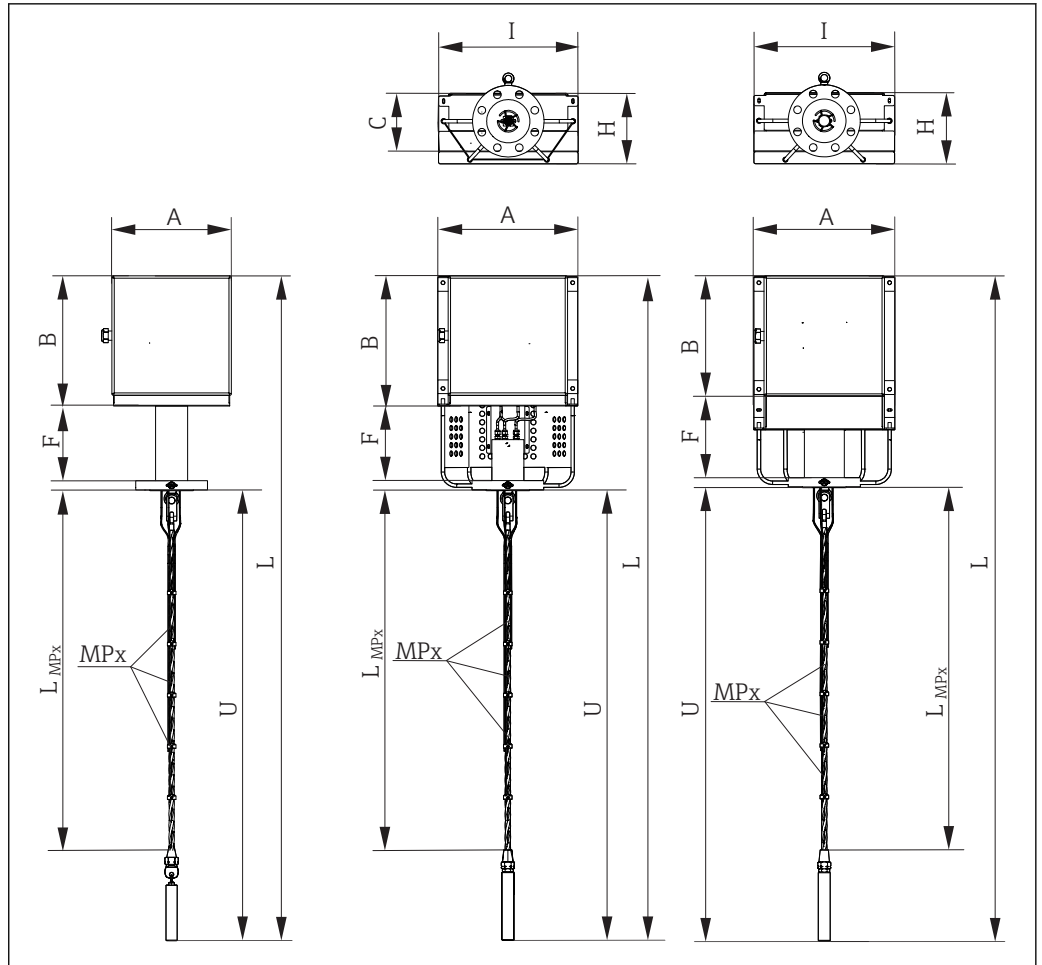

A0038299

8 Design of the modular multipoint thermometer, with tube neck on the left side, frame neck on the middle or with tube neck design as option on the right side. All dimensions in mm (in)

A, B, Dimensions of the junction box, see following figure

C

MPx Numbers and distribution of measuring points: MP1, MP2, MP3 etc.

$L_{MPx}$  Immersion length of sensing elements or thermowells

I, H Encumbrance of the junction box and support system

F Extension neck length

L Device length

U Immersion length

**Extension neck F in mm (in)**

Standard 250 (9.84)

Specifically customized extension necks are available on request.

**Immersion lengths MPx of sensing elements/thermowells:**

Based on customer requirements

Rope maximum load:					
	Rope Ø mm	Construction	Weight kg/m	MBL	
				kN	kg
 <p>A0038300</p> <ul style="list-style-type: none"> <li>Stainless steel AISI 316</li> <li>Rope according to EN 10264-4</li> <li>Rope grade 1.570 N/mm<sup>2</sup></li> </ul>	6	1x19	0,1786	29,5	3000
	8	1x19	0,322	53	5400
	10	1x19	0,502	84	8500

**Junction box (directly mounted)**

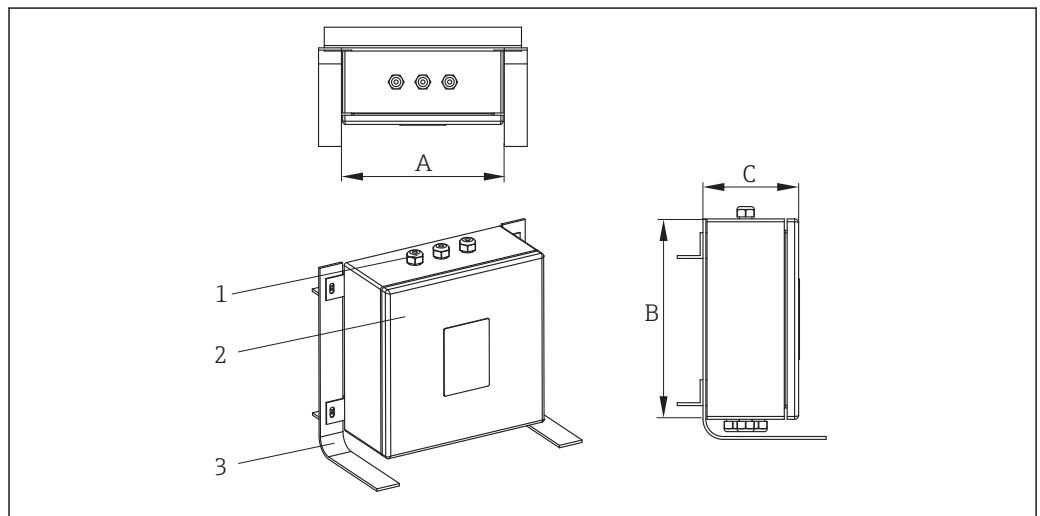

A0028118

- 1 Cable glands
- 2 Junction box
- 3 Frame

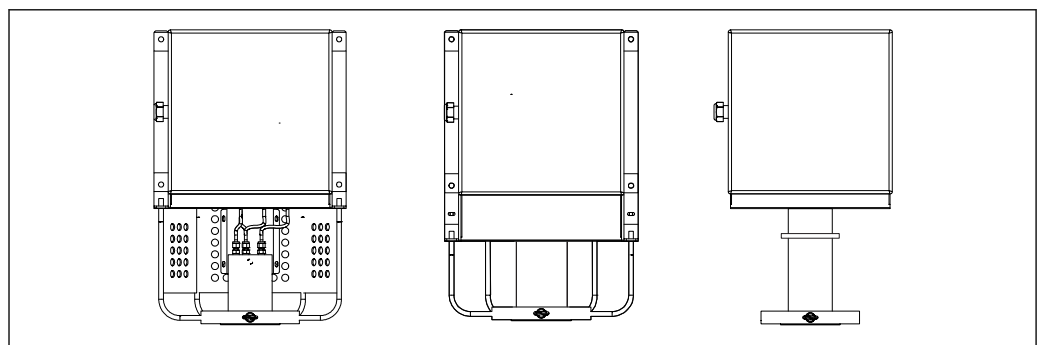

A0038301

- 9 Open design on the left side, with cover design in the middle and tube neck design on the right side



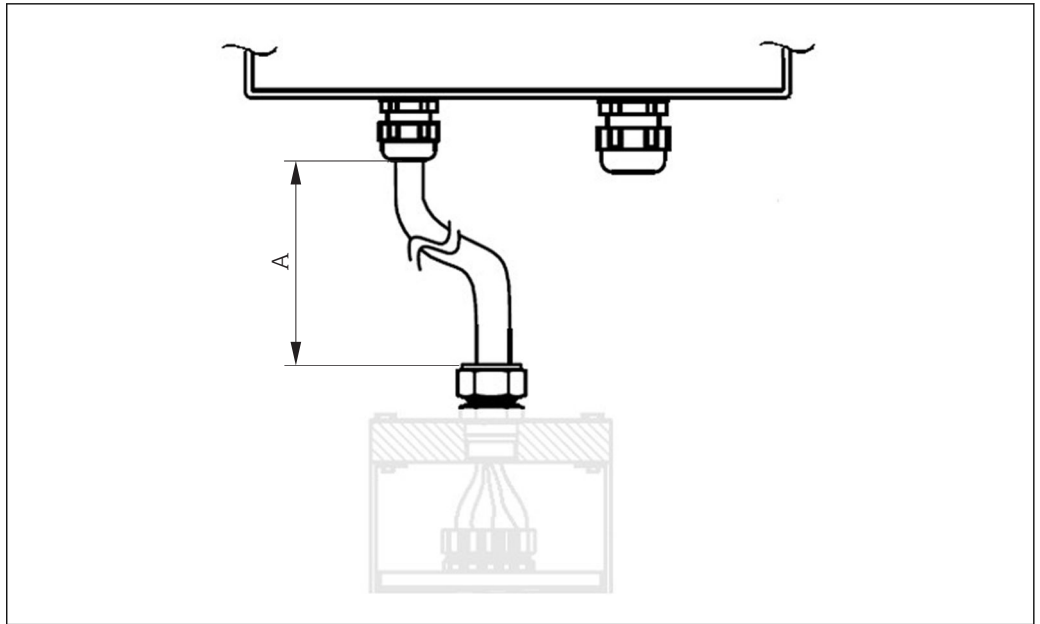

A0038302

10 Remote junction box design

The junction box is suited for chemical agents environments. Sea water corrosion resistance and extreme temperature variation stability is guaranteed. Ex-e Ex-i terminals can be installed.

Possible junction box dimensions (A x B x C) in mm (in):

		A	B	C
<b>Stainless Steel</b>	Min.	170 (6.7)	170 (6.7)	130 (5.1)
	Max.	500 (19.7)	500 (19.7)	240 (9.5)
<b>Aluminium</b>	Min.	100 (3.9)	150 (5.9)	80 (3.2)
	Max.	330 (13)	500 (19.7)	180 (7.1)

Type of specification	Junction box	Cable glands
Material	AISI 316/Aluminium	NiCr Plated brass AISI 316 / 316L
Ingress protection (IP)	IP66/67	IP66
Ambient temperature range	-50 to +60 °C (-58 to +140 °F)	-52 to +110 °C (-61.1 to +140 °F)
Approvals	ATEX, FM, UL, CSA approval for use in hazardous area IEC	-
Marking	<ul style="list-style-type: none"> <li>■ ATEX II 2 GD Ex e IIC /Ex ia Ga IIC Ex tb IIIC Db T6/T5/T4</li> <li>■ UL913 Class I, Division 1 Groups B, C, D T6/T5/T4</li> <li>■ FM3610 Class I, Division 1 Groups B, C, D T6/T5/T4</li> <li>■ CSA C22.2 No. 157 Class 1, Division 1 Groups B, C, D T6/T5/T4</li> </ul>	-
Cover	Hinged	-
Maximum sealing diameter	-	6 to 12 mm (0.24 to 0.47 in)

		On board	Remote
Type of protection	Intrinsically safe and increased safety	<ul style="list-style-type: none"> <li>■ With frame</li> <li>■ Tube neck</li> </ul>	Flexible conduit
	Flameproof	With supporting frame	

### Field display

Power:	100-240 Vac, 50-60 Hz, 25 VA, 0.375 A max
Certification:	ATEX II 2 G D Ex 'd' IIC T6, IP 66
Environment:	Hazardous Area Zone 1
Operating temperature:	-20 °C to +55 °C
Storage temperature:	-40 °C to +85 °C
Enclosure:	Aluminium alloy Painted RAL 7035 grey epoxy
IP rating:	IP66
Entries:	M20 threaded entries (quantity 5 off)
External dimensions:	300 x 230 x 155 mm
Fixings:	To suit M12 bolts, four positions
Weight:	7.5 kg
No. of host ports:	4 Ports
Interfaces supported:	RS-232, RS-422/485, Modbus RTU HART®

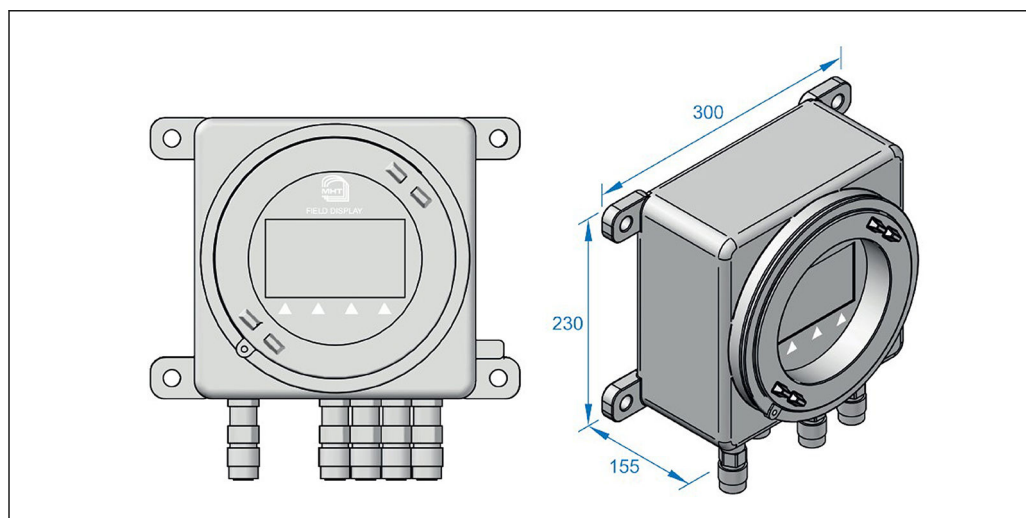

A0038303

### Neck extension

The neck extension ensures the connection between the flange and the junction box. The design has been developed to ensure several mounting layouts to deal with possible obstacles and constraints that can be met in any plant such as the storage tank infrastructure (step ways, loading structures, stairs, etc.) and an eventual thermal insulation. The neck extension design allows easy access for monitoring extension cables. It guarantees a high stiffness connection for the junction box and vibration loads. No closed volumes are present in the neck extension (not for tube neck design). This avoids the accumulation of waste and potentially dangerous fluids coming from the environment that can damage the instrumentation allowing continuous ventilation.

**Inserts**

Different insert types are available. For any different requirement that is not described here, please contact the Endress+Hauser sales department.

*Thermocouple*

Diameter in mm (in)	Type	Standard	Hot junction type	Sheath material
3 (0.12)	1x type K 2x type K 1x type J 2x type J	IEC 60584 / ASTM E230	Grounded/Ungrounded	AISI 316L

*RTD*

Diameter in mm (in)	Type	Standard	Sheath material
3 (0.12) 6 (1/4)	1x Pt100 WW 2x Pt100 WW 1x Pt100 TF 2x Pt100 TF	IEC 60751	AISI 316L

**Weight**

The weight can vary depending on the configuration: Dimension and content of the junction box, neck length, dimensions of process connection, the number of inserts and the weight of the rope end. The approximate weight of a typically configured multipoint rope (number of inserts = 12, flange size = 3", medium size junction box) = 55 kg (121 lb)

**Materials**

It refers to insert sheath, neck extension, junction box and all wetted parts.

The temperatures for continuous operation specified in the following table are only intended as reference values for use of the various materials in air and without any significant compressive load. The maximum operation temperatures are reduced considerably in some cases where abnormal conditions such as high mechanical load occur or in aggressive media.

Material name	Short form	Recommended max. temperature for continuous use in air	Properties
AISI 316/1.4401	X5CrNiMo 17-12-2	650 °C (1202 °F)	<ul style="list-style-type: none"> <li>▪ Austenitic, stainless steel</li> <li>▪ High corrosion resistance in general</li> <li>▪ Particularly high corrosion resistance in chlorine-based and acidic, non-oxidizing atmospheres through the addition of molybdenum (e.g. phosphoric and sulfuric acids, acetic and tartaric acids with a low concentration)</li> </ul>
AISI 316L/ 1.4404 1.4435	X2CrNiMo17-12-2 X2CrNiMo18-14-3	650 °C (1202 °F)	<ul style="list-style-type: none"> <li>▪ Austenitic, stainless steel</li> <li>▪ High corrosion resistance in general</li> <li>▪ Particularly high corrosion resistance in chlorine-based and acidic, non-oxidizing atmospheres through the addition of molybdenum (e.g. phosphoric and sulfuric acids, acetic and tartaric acids with a low concentration)</li> <li>▪ Increased resistance to intergranular corrosion and pitting</li> <li>▪ Compared to 1.4404, 1.4435 has even higher corrosion resistance and a lower delta ferrite content</li> </ul>
Alloy600/ 2.4816	NiCr15Fe	1100 °C (2012 °F)	<ul style="list-style-type: none"> <li>▪ A nickel/chromium alloy with very good resistance to aggressive, oxidizing and reducing atmospheres, even at high temperatures</li> <li>▪ Resistance to corrosion caused by chlorine gases and chlorinated media as well as many oxidizing mineral and organic acids, sea water etc.</li> <li>▪ Corrosion from ultrapure water</li> <li>▪ Not to be used in sulfur-containing atmospheres</li> </ul>

Material name	Short form	Recommended max. temperature for continuous use in air	Properties
AISI 304/1.4301	X5CrNi18-10	850 °C (1 562 °F)	<ul style="list-style-type: none"> <li>▪ Austenitic, stainless steel</li> <li>▪ Well usable in water and lowly pollute waste water</li> <li>▪ Only at relatively low temperatures resistant to organic acids, saline solutions, sulphates, alkaline solutions, etc.</li> </ul>
AISI 304L/ 1.4307	X2CrNi18-9	850 °C (1 562 °F)	<ul style="list-style-type: none"> <li>▪ Good welding properties</li> <li>▪ Impervious to intergranular corrosion</li> <li>▪ High ductility, excellent drawing, forming, and spinning properties</li> </ul>
AISI 316Ti/ 1.4571	X6CrNiMoTi17-12-2	700 °C (1 292 °F)	<ul style="list-style-type: none"> <li>▪ Addition of titanium means increased resistance to intergranular corrosion even after welding</li> <li>▪ Broad range of uses in the chemical, petrochemical and oil industries as well as in coal chemistry</li> <li>▪ Can only be polished to a limited extent, titanium streaks can form</li> </ul>
AISI 321/1.4541	X6CrNiTi18-10	815 °C (1 499 °F)	<ul style="list-style-type: none"> <li>▪ Austenitic stainless steel</li> <li>▪ High resistance to intergranular corrosion even after welding</li> <li>▪ Good welding characteristics, suitable to all standard welding methods</li> <li>▪ It is used in many sectors of the chemical industry, petrochemical, and pressurized vessels</li> </ul>
AISI 347/1.4550	X6CrNiNb10-10	800 °C (1 472 °F)	<ul style="list-style-type: none"> <li>▪ Austenitic stainless steel</li> <li>▪ Good resistance to a wide variety of environments in the chemical, textile, oil-refining, dairy and food industries</li> <li>▪ Added niobium makes this steel impervious to intergranular corrosion</li> <li>▪ Good weldability</li> <li>▪ Main applications are furnace fire walls, pressure vessels, welded structures, turbine blades</li> </ul>

### Process connection

Standard process connection flanges are designed according to the following standards:

Standard <sup>1)</sup>	Size	Rating	Material
ASME	1½", 2", 3", 4"	150#, 300#	AISI 316, 316L, 316Ti
EN	DN40, DN50, DN80, DN100	PN16, PN40	

1) Flanges according to GOST standard are available on request.

## Operability

For details of operability, see the Technical Information of the Endress+Hauser temperature transmitters or the manuals of the related operating software. →  27

## Certificates and approvals

<b>CE Mark</b>	The complete assembly is provided with individual components CE marked, to ensure safe use in hazardous areas and pressurized environments.
<b>Hazardous area approvals</b>	The Ex approval applies to individual components like junction box, cable glands, terminals. For further details on the available Ex versions (ATEX, CSA, FM, IEC-EX, UL, NEPSI, EAC-EX), please contact your nearest Endress+Hauser sales organization. All relevant data for hazardous areas can be found in separate Ex documentation.
<b>Certification HART</b>	The HART® temperature transmitter is registered by the FieldComm Group. The device meets the requirements of the HART® Communication Protocol Specifications.
<b>Certification FOUNDATION Fieldbus</b>	The FOUNDATION Fieldbus™ temperature transmitter has successfully passed all test procedures and is certified and registered by the Fieldbus Foundation. The device thus meets all the requirements of the following specification: <ul style="list-style-type: none"> <li>▪ Certified according to FOUNDATION Fieldbus™ specification</li> <li>▪ FOUNDATION Fieldbus™ H1</li> <li>▪ Interoperability Test Kit (ITK), up to date revision status (device certification no. available on request): the device can also be operated with certified devices of other manufacturers</li> <li>▪ Physical layer conformance test of the FOUNDATION Fieldbus™</li> </ul>
<b>Certification PROFIBUS® PA</b>	The PROFIBUS® PA temperature transmitter is certified and registered by the PNO (PROFIBUS® Nutzerorganisation e. V.), PROFIBUS user organization. The device meets all the requirements of the following specifications: <ul style="list-style-type: none"> <li>▪ Certified according to FOUNDATION Fieldbus™ specification</li> <li>▪ Certified in accordance with PROFIBUS® PA Profile (the up to date profile version is available on request)</li> <li>▪ The device can also be operated with certified devices of other manufacturers (interoperability)</li> </ul>
<b>Other standards and guidelines</b>	<ul style="list-style-type: none"> <li>▪ EN 60079: ATEX certification for hazardous areas</li> <li>▪ IEC 60529: Degree of protection of housing (IP code)</li> <li>▪ IEC 60584 and ASTM E230/ANSI MC96.1: Thermocouples</li> </ul>
<b>Material certification</b>	The material certificate 3.1 (according to EN 10204) can be requested separately. The certificate includes a declaration related to the materials used to produce the thermometer. It guarantees the traceability of the materials through the identification number of the rope multipoint thermometer.
<b>Test report and calibration</b>	The "Factory calibration" is carried out according to an internal procedure in a laboratory of Endress+Hauser accredited by the European Accreditation Organization (EA) to ISO/IEC 17025. A calibration which is performed according to EA guidelines (SIT/Accredia) or (DKD/DAkkS) may be requested separately. The calibration is performed on the inserts of the multipoint.

## Ordering information

Overview of the scope of delivery see the configuration table below.

Detailed ordering information is available from your Endress+Hauser Sales Center:

[www.addresses.endress.com](http://www.addresses.endress.com)

Process connection: Flange		
Standard	<ul style="list-style-type: none"> <li>▪ ASME B16.5</li> <li>▪ EN 1092-1</li> </ul> Others on request	<input type="checkbox"/> <input type="checkbox"/>
Material	<ul style="list-style-type: none"> <li>▪ 316</li> <li>▪ 316L</li> <li>▪ 316TI</li> </ul> Others on request	<input type="checkbox"/> <input type="checkbox"/> <input type="checkbox"/>
Face	RF, Type A, B1 Others on request	<input type="checkbox"/>
Size	<ul style="list-style-type: none"> <li>▪ 1½", 2", 3", 4"</li> <li>▪ DN40, DN50, DN80, DN100</li> </ul> Others on request	_____ _____

 The values reported in the table below are indicative, based on calculations for nozzles with standard dimensions. So the maximum number of measurement points can differ from the maximum number of the configuration table. It depends on the dimensions of the nozzle used on location.

Flange size (considering a schedule 40 nozzle)	Maximum number of inserts	
	Inserts diameter	
	3 mm (0.12 in)	6 mm (0.24 in)
1½"	10	4
2"	15	8
3"	20	20
4"	20	20

Insert, sensor		
Measuring principle	<ul style="list-style-type: none"> <li>▪ Thermocouple (TC)</li> <li>▪ Resistance Temperature Detection (RTD)</li> </ul>	<input type="checkbox"/> <input type="checkbox"/>
Type	TC: J, K RTD: Pt100	_____
Design	<ul style="list-style-type: none"> <li>▪ TC: Single, duplex</li> <li>▪ RTD: 3-wire, 4-wire, 2x3-wire</li> </ul>	<input type="checkbox"/> <input type="checkbox"/>
Execution	<ul style="list-style-type: none"> <li>▪ TC: Grounded, Ungrounded</li> <li>▪ RTD: Wire wound (WW); Thin film (TF)</li> </ul>	<input type="checkbox"/> <input type="checkbox"/>
Sheath material	316L	_____
Approvals	<ul style="list-style-type: none"> <li>▪ Intrinsic safety</li> <li>▪ Non hazardous</li> </ul>	_____

Insert, sensor		
Insert, sensor	<ul style="list-style-type: none"> <li>■ 3 mm (0.12 in)</li> <li>■ 6 mm (0.24 in)</li> </ul> Others on request	<input type="checkbox"/> <input type="checkbox"/>
Standard/Class	IEC/Class 1 ASTM/Class special IEC/Class 2 ASTM/Class standard IEC/Class A IEC/Class AA Others on request	<input type="checkbox"/> <input type="checkbox"/> <input type="checkbox"/> <input type="checkbox"/> <input type="checkbox"/> <input type="checkbox"/>

Measurement point distribution		
Positioning	<ul style="list-style-type: none"> <li>■ Equi spaced</li> <li>■ Customized</li> </ul>	<input type="checkbox"/> <input type="checkbox"/>
Number	2, 4, 6, 8, 10, 12 ... 20 <sup>1)</sup>	_____
Insertion length	TAG (description)	(L <sub>MPx</sub> ) in mm (in)
MP <sub>1</sub>	_____	_____
MP <sub>2</sub>	_____	_____
MP <sub>3</sub>	_____	_____
MP <sub>4</sub>	_____	_____
MP <sub>5</sub>	_____	_____
MP <sub>6</sub>	_____	_____
MP <sub>x</sub>	_____	_____

1) Different numbers/configurations are available on request

Junction box (head)		
Material	<ul style="list-style-type: none"> <li>■ Stainless steel (standard)</li> <li>■ Aluminum (to be specified)</li> </ul> Others on request	<input type="checkbox"/> <input type="checkbox"/>
Electrical connection	Terminal block wiring: <ul style="list-style-type: none"> <li>■ Terminal block - standard/number</li> <li>■ Terminal block - compensated/number</li> <li>■ Terminal block - spare/number</li> </ul> Transmitter wiring: <ul style="list-style-type: none"> <li>■ HART protocol, e. g.: TMT182, TMT82</li> <li>■ PROFIBUS PA protocol, e. g.: TMT84</li> <li>■ FOUNDATION Fieldbus protocol, e. g.: TMT85, TMT125 (multi-channel transmitter)</li> <li>■ Quantity</li> </ul>	<input type="checkbox"/> / _____ <input type="checkbox"/> / _____ <input type="checkbox"/> / _____ <input type="checkbox"/> <input type="checkbox"/> <input type="checkbox"/> _____
Approvals	Ex e / Ex ia / Ex d Others on request	_____
Cable entries (process side)	Single or multiple, type: M20, NPT ½", Quantity Others on request	_____ / _____ _____ / _____
Cable entries (wiring side)	Single or multiple, type: M20, M25, NPT ½", NPT 1" / Quantity Others on request	_____ / _____ _____ / _____

Junction Box supporting frame		
<ul style="list-style-type: none"> <li>▪ Remote with protecting hose</li> <li>▪ Remote without protecting hose</li> <li>▪ Directly mounted</li> </ul>		<input type="checkbox"/> <input type="checkbox"/> <input type="checkbox"/>

Extension neck		
Length F in mm (in)	250 mm (9.84 in) Or as specified	<input type="checkbox"/>

TAG		
Device information	Refer to customer specification As specified	<input type="checkbox"/> <input type="checkbox"/> (table)
Measuring point information	Refer to customer specification Location, as specified: <ul style="list-style-type: none"> <li>▪ Tagging (TAG), on extension wires insert</li> <li>▪ Tagging (TAG), RFID</li> <li>▪ Tagging (TAG), on device</li> <li>▪ Tagging (TAG), by customer</li> <li>▪ Tagging (TAG), on transmitter</li> </ul> Special version, to be specified	<input type="checkbox"/> <input type="checkbox"/> <input type="checkbox"/> <input type="checkbox"/> <input type="checkbox"/> <input type="checkbox"/> <input type="checkbox"/>

Additional requests		
Extension wire length, only for remote head	Specification in mm:	_____
Extension wires sheath material	<ul style="list-style-type: none"> <li>▪ PVC</li> <li>▪ MFA</li> </ul> Others on request	<input type="checkbox"/> <input type="checkbox"/>

Test, Certificate, Declaration		
Inspection certificate 3.1, EN10204 (material certificate wetted parts)		<input type="checkbox"/>
Inspection certificate 3.1, short form, EN10204, (material certificate wetted parts)		<input type="checkbox"/>
PMI test, Endress+Hauser procedure, (wetted parts), test report		<input type="checkbox"/>
Final assembly functional test, test report		<input type="checkbox"/>
Final inspection report		<input type="checkbox"/>
2D dimensional drawing		<input type="checkbox"/>
Welding book (including welding map)		<input type="checkbox"/>
Radiographic inspection certificate on hot junctions/tips for sensors		<input type="checkbox"/>
Manufacturer declaration		<input type="checkbox"/>
Dye penetrant test, test report		<input type="checkbox"/>
Inspection test report (Sensor/TMT), inspection certificate		<input type="checkbox"/>
Quality control plan		<input type="checkbox"/>







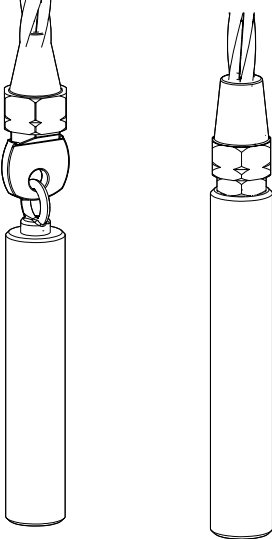
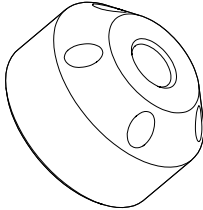
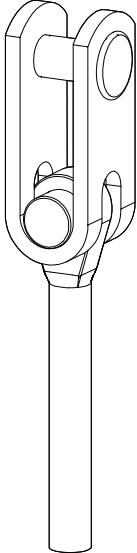

## Accessories

Various accessories, which can be ordered with the device or subsequently from Endress+Hauser, are available for the device. Detailed information on the order code in question is available from your local Endress+Hauser sales center.

### Device-specific accessories

Accessories	Description
<p data-bbox="678 439 815 465">Anchor weight</p>  <p data-bbox="933 1043 986 1059">A0038304</p>	<p data-bbox="999 439 1517 595">The installation of the anchor weight ensures a straight vertical position of the rope, please make sure to have enough space for a correct weight positioning inside the storage system. The dimensions will be established during the order development according to the rope multipoint dimension.</p> <ul data-bbox="999 607 1342 663" style="list-style-type: none"> <li>■ Left side - Removable/Replaceable</li> <li>■ Right side - Fixed</li> </ul>
<p data-bbox="715 1077 778 1104">Ogives</p>  <p data-bbox="933 1350 986 1366">A0038305</p>	<p data-bbox="999 1077 1525 1178">Ogives are integrated in the multipoint rope, they provide a correct positioning of the probe thermoelement along the rope length and maintain them in position under working condition.</p>
<p data-bbox="651 1384 847 1411">Toggle joint terminal</p>  <p data-bbox="933 2000 986 2016">A0038306</p>	<p data-bbox="999 1384 1525 1440">Toggle joint connection between rope and flange to allow reciprocal rotation.</p>

**Communication-specific accessories**

Configuration kit TXU10	Configuration kit for PC-programmable transmitter with setup software and interface cable for PC with USB port Order code: TXU10-xx
Commubox FXA195 HART	For intrinsically safe HART communication with FieldCare via the USB interface.  For details, see "Technical Information" TI00404F
Commubox FXA291	Connects Endress+Hauser field devices with a CDI interface (= Endress+Hauser Common Data Interface) and the USB port of a computer or laptop.  For details, see "Technical Information" TI00405C
HART Loop Converter HMX50	Is used to evaluate and convert dynamic HART process variables to analog current signals or limit values.  For details, see "Technical Information" TI00429F and Operating Instructions BA00371F
Wireless HART adapter SWA70	Is used for the wireless connection of field devices. The WirelessHART adapter can be easily integrated into field devices and existing infrastructures, offers data protection and transmission safety and can be operated in parallel with other wireless networks with minimum cabling complexity.  For details, see Operating Instructions BA061S
Fieldgate FXA320	Gateway for the remote monitoring of connected 4-20 mA measuring devices via a Web browser.  For details, see "Technical Information" TI00025S and Operating Instructions BA00053S
Fieldgate FXA520	Gateway for the remote diagnostics and remote configuration of connected HART measuring devices via a Web browser.  For details, see "Technical Information" TI00025S and Operating Instructions BA00051S
Field Xpert SFX100	Compact, flexible and robust industry handheld terminal for remote configuration and for obtaining measured values via the HART current output (4-20 mA).  For details, see Operating Instructions BA00060S

**Service-specific accessories**

Accessories	Description
Applicator	Software for selecting and sizing Endress+Hauser measuring devices: <ul style="list-style-type: none"> <li>■ Calculation of all the necessary data for identifying the optimum measuring device: e.g. pressure loss, accuracy or process connections.</li> <li>■ Graphic illustration of the calculation results</li> </ul> Administration, documentation and access to all project-related data and parameters over the entire life cycle of a project. Applicator is available: <ul style="list-style-type: none"> <li>■ Via the Internet: <a href="https://wapps.endress.com/applicator">https://wapps.endress.com/applicator</a></li> <li>■ On CD-ROM for local PC installation.</li> </ul>
W@M	Life cycle management for your plant W@M supports you with a wide range of software applications over the entire process: from planning and procurement, to the installation, commissioning and operation of the measuring devices. All the relevant device information, such as the device status, spare parts and device-specific documentation, is available for every device over the entire life cycle. The application already contains the data of your Endress+Hauser device. Endress+Hauser also takes care of maintaining and updating the data records. W@M is available: <ul style="list-style-type: none"> <li>■ Via the Internet: <a href="http://www.endress.com/lifecyclemanagement">www.endress.com/lifecyclemanagement</a></li> <li>■ On CD-ROM for local PC installation.</li> </ul>

FieldCare	<p>FDT-based plant asset management tool from Endress+Hauser. It can configure all smart field units in your system and helps you manage them. By using the status information, it is also a simple but effective way of checking their status and condition.</p> <p> For details, see Operating Instructions BA00027S and BA00059S</p>
-----------	--

## Documentation

- Operating manuals iTEMP temperature transmitters:
  - TMT180, PC-programmable, single-channel, Pt100 (KA00118R/09/a3)
  - TMT181, PC programmable, single-channel, RTD, TC, Ω, mV (KA141R/09/a3)
  - HART® TMT182, single-channel, RTD, TC, Ω, mV (KA142R/09/c4)
  - HART® TMT82, two-channel, RTD, TC, Ω, mV (BA01028T/09/en)
  - PROFIBUS® PA TMT84, two-channel, RTD, TC, Ω, mV (BA00257R/09/en)
  - FOUNDATION Fieldbus™ TMT85, two-channel, RTD, TC, Ω, mV (BA00251R/09/en)
  - FOUNDATION Fieldbus™ TMT125, 8-channel, RTD, TC, Ω, mV (BA00240R/09/en)
  - Safety requirements: DIN EN 61010-1:2011-07
  - EMC requirements : DIN EN 61326-1:2013-07
  - RSG45 DIN RAIL
  - TMT162
  - TMT142
  - Field Display (FD188)
- Technical Information of inserts:
  - Resistance thermometer insert Omnigrad T TST310 (TI00085T/09/en)
  - Thermocouple insert Omnigrad T TSC310 (TI00255t/09/en)
- Technical Information application example:
  - RN221N active barrier, for supplying loop-powered 2-wire transmitters (TI073R/09/en)
  - HAW562 surge arresters, (TI01012K/09/en)

[www.addresses.endress.com](http://www.addresses.endress.com)

---