

# Operating Instructions

## **iTHERM TMS21**

### **MultiSens Slim**

Low invasive direct contact multipoint thermometer

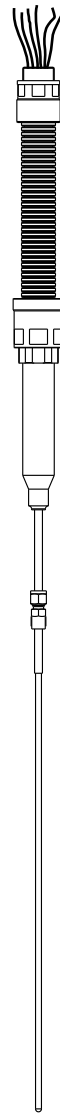



## Table of contents

<b>1</b>	<b>About this document</b> .....	<b>4</b>	<b>10</b>	<b>Accessories</b> .....	<b>28</b>
1.1	Document function .....	4	10.1	Device-specific accessories .....	28
1.2	Symbols .....	4	10.2	Communication-specific accessories .....	29
			10.3	Service-specific accessories .....	30
<b>2</b>	<b>Basic safety instructions</b> .....	<b>6</b>	<b>11</b>	<b>Technical data</b> .....	<b>31</b>
2.1	Requirements for the personnel .....	6	11.1	Input .....	31
2.2	Designated use .....	6	11.2	Output .....	31
2.3	Workplace safety .....	7	11.3	Power supply .....	32
2.4	Operational safety .....	7	11.4	Performance characteristics .....	33
2.5	Product safety .....	7	11.5	Installation .....	35
<b>3</b>	<b>Product description</b> .....	<b>8</b>	11.6	Environment .....	37
3.1	Product design .....	8	11.7	Mechanical construction .....	38
<b>4</b>	<b>Incoming acceptance and product identification</b> .....	<b>11</b>	11.8	Operability .....	41
4.1	Incoming acceptance .....	11	11.9	Certificates and approvals .....	42
4.2	Product identification .....	11	11.10	Documentation .....	43
4.3	Storage and transport .....	12			
<b>5</b>	<b>Mounting</b> .....	<b>13</b>			
5.1	Mounting requirements .....	13			
5.2	Mounting the assembly .....	13			
5.3	Post-mounting check .....	16			
<b>6</b>	<b>Wiring</b> .....	<b>17</b>			
6.1	Quick wiring guide .....	17			
6.2	Connecting the sensor cables .....	19			
6.3	Connecting the power supply and signal cables .....	20			
6.4	Shielding and grounding .....	21			
6.5	Degree of protection .....	21			
6.6	Post-connection check .....	22			
<b>7</b>	<b>Commissioning</b> .....	<b>23</b>			
7.1	Preliminaries .....	23			
7.2	Function check .....	23			
7.3	Switching on the device .....	25			
<b>8</b>	<b>Diagnostics and troubleshooting</b> ...	<b>25</b>			
8.1	General troubleshooting .....	25			
<b>9</b>	<b>Repair</b> .....	<b>26</b>			
9.1	General notes .....	26			
9.2	Spare parts .....	26			
9.3	Endress+Hauser services .....	26			
9.4	Return .....	26			
9.5	Disposal .....	26			





# 1 About this document

## 1.1 Document function





These Operating Instructions contain all the information that is required in various phases of the life cycle of the device: from product identification, incoming acceptance and storage, to mounting, connection, operation and commissioning through to troubleshooting, maintenance and disposal.

## 1.2 Symbols



### 1.2.1 Safety symbols









Symbol	Meaning
	<b>DANGER!</b> This symbol alerts you to a dangerous situation. Failure to avoid this situation will result in serious or fatal injury.
	<b>WARNING!</b> This symbol alerts you to a dangerous situation. Failure to avoid this situation can result in serious or fatal injury.
	<b>CAUTION!</b> This symbol alerts you to a dangerous situation. Failure to avoid this situation can result in minor or medium injury.
	<b>NOTE!</b> This symbol contains information on procedures and other facts which do not result in personal injury.

### 1.2.2 Electrical symbols

Symbol	Meaning
	Direct current
	Alternating current
	Direct current and alternating current
	<b>Ground connection</b> A grounded terminal which, as far as the operator is concerned, is grounded via a grounding system.
	<b>Protective Earth (PE)</b> A terminal which must be connected to ground prior to establishing any other connections.  The ground terminals are situated inside and outside the device: <ul style="list-style-type: none"> <li>▪ Inner ground terminal: Connects the protective earth to the mains supply.</li> <li>▪ Outer ground terminal: Connects the device to the plant grounding system.</li> </ul>

### 1.2.3 Symbols for certain types of information

Symbol	Meaning
	<b>Permitted</b> Procedures, processes or actions that are permitted.
	<b>Preferred</b> Procedures, processes or actions that are preferred.

Symbol	Meaning
	<b>Forbidden</b> Procedures, processes or actions that are forbidden.
	<b>Tip</b> Indicates additional information.
	Reference to documentation
	Reference to page
	Reference to graphic
	Series of steps
	Result of a step
	Help in the event of a problem
	Visual inspection

### 1.2.4 Documentation

Document	Purpose and content of the document
iTHERM MultiSens Slim TMS21 (TI01298T/09)	<b>Planning aid for your device</b> The document contains all the technical data on the device and provides an overview of the accessories and other products that can be ordered for the device.

 The document types listed are available:  
In the Download Area of the Endress+Hauser Internet site: [www.endress.com](http://www.endress.com) → Downloads

### 1.2.5 Registered trademarks

- FOUNDATION™ Fieldbus  
Registered trademark of the Fieldbus Foundation, Austin, Texas, USA
- HART®  
Registered trademark of the HART® FieldComm Group
- PROFIBUS®  
Registered trademark of the PROFIBUS Nutzerorganisation e.V. (Profibus User Organization), Karlsruhe - Germany

## 2 Basic safety instructions

Instructions and procedures in the operating instructions may require special precautions to ensure the safety of the personnel performing the operations. Information that potentially raises safety issues is indicated by safety pictograms and symbols. Please refer to the safety messages before performing an operation preceded by pictograms and symbols. Although the information provided herein is believed to be accurate, be advised that the information contained herein is NOT a guarantee of satisfactory results. Specifically, this information is neither a warranty nor guarantee, expressed or implied, regarding performance. Please note that the manufacturer reserves the right to change and / or improve the product design and specifications without notice.

### 2.1 Requirements for the personnel

The personnel for installation, commissioning, diagnostics and maintenance must fulfill the following requirements:

- ▶ Trained, qualified specialists must have a relevant qualification for this specific function and task
- ▶ Are authorized by the plant owner/operator
- ▶ Are familiar with federal/national regulations
- ▶ Before beginning work, the specialist staff must have read and understood the instructions in the Operating Instructions and supplementary documentation as well as in the certificates (depending on the application)
- ▶ Following instructions and basic conditions

The operating personnel must fulfill the following requirements:

- ▶ Being instructed and authorized according to the requirements of the task by the facility's owner-operator
- ▶ Following the instructions in these Operating Instructions

### 2.2 Designated use

The product is intended to measure the temperature profile inside a reactor, vessel or pipe through RTD or thermocouple technologies.

The manufacturer is not liable for damage caused by improper or non-designated use.

The product has been designed according to the following conditions:

Condition	Description
Internal pressure	The design of joints, threaded connections and sealing elements has been executed as a function of the maximum allowable pressure inside the reactor.
Operating temperature	The materials used were chosen according to the operating and design minimum and maximum temperatures. Thermal displacement has been taken into account to avoid intrinsic stresses and to ensure proper integration between the instrument and the plant. Specific care has to be taken when the instrument's sensing elements are fixed to the plant internals.
Process fluids	Dimensions and choice of materials minimize: <ul style="list-style-type: none"> <li>▪ distributed and localized corrosion,</li> <li>▪ erosion and abrasion,</li> <li>▪ corrosion phenomena due to uncontrolled and unpredictable chemical reactions.</li> </ul> Specific process fluids analysis is necessary to properly ensure the maximum operating life of the device, through proper material selection.
Fatigue	Cyclic loads during operations are not foreseen.

Condition	Description
Vibrations	The sensing elements can be subjected to vibrations, due to high immersion lengths from the constraint located in the process connections. This vibrations can be minimized by properly selecting the route of the sensing element into the plant, by fixing it on internals by means of accessories like clips and end tips. The extension neck has been designed for withstanding vibratory loads to preserve the junction box from cyclic loading, and to avoid the unscrewing of the threaded components.
Mechanical stress	The maximum stress on the measuring device multiplied by a safety factor is guaranteed to stay below the yielding stress of the material, for every working condition of the plant.
External environment	The junction box (with and without head transmitters), wires, cable glands and other fittings have been selected to work within the allowed ranges in terms of external temperature.

## 2.3 Workplace safety

The external installation area must be free of interferences to avoid any injury during installation, and to avoid any damage to the measuring device.

## 2.4 Operational safety

- ▶ Operate the device in proper technical condition and fail-safe condition only.
- ▶ The operator is responsible for interference-free operation of the device.

### Hazardous area

To eliminate a danger for persons or for the facility when the device is used in the hazardous area (e.g. explosion protection or safety equipment):

- ▶ Based on the technical data on the nameplate, check whether the ordered device is permitted for the intended use in the hazardous area. The nameplate can be found on the side of the junction box, if ordered.
- ▶ Observe the specifications in the separate supplementary documentation that is an integral part of these Instructions.

### Electromagnetic compatibility

The measuring system complies with the general safety requirements in accordance with EN 61010-1, the EMC requirements of IEC/EN 61326 and NAMUR Recommendation NE 21 and NE 89.

### NOTICE

- ▶ The unit must only be powered by a power supply that operates using an energy-limited electric circuit that is compliant with IEC 61010-1, "SELV or Class 2 circuit".

## 2.5 Product safety

The unit is constructed using the most up-to-date production equipment and complies with the safety requirements of the local guidelines. The temperature measuring system is fully factory tested according to the specifications indicated on the order and/or any additional test which is considered as safety-relevant. However, if it is installed incorrectly or is misused, certain application dangers can occur. Installation, wiring and maintenance of the unit must only be done by trained, skilled personnel who are authorized to do so by the plant operator. This skilled staff must have read and understood these instructions and must follow them. The plant operator must make sure that the measurement system has been installed by tightening the threaded components (e.g bolts and nuts) with the predefined torques and tools XREF Mounting S9, and correctly wired according to the wiring diagrams. XREF Wiring S9

## 3 Product description

### 3.1 Product design

The new iTHERM MultiSens Slim has an innovative design able to allow a wide variety of options in terms of materials selection, sizes and number of measuring points. In addition a portfolio of selectable accessories (not in contact with the process) individually managed for easy maintenance and spare part ordering, like adapters and conduits, is available.

It consists of five main sub-assemblies:

- **Extension:** It consists of a threaded bushing for sealed electrical connections, matched to an adapter from which flexible conduit containing the extension cables.
- **Main bushing and reinforcing sleeve:**
- **Process connection:** The process connection is represented by a compression fitting. When necessary, an ASME or EN flange is available on request. Other standards or connection types can be offered on request. The flanges are provided with welded compression fitting for process tightness.
- **Thermowell:** with or without reinforcing sleeve
- **Insert:** Composed of metal sheathed sensing measuring elements (thermocouples), extension cable and transition bushing. The sensing elements are mounted inside a small diameter pipe thermowell. Part of the thermowell can be a flexible hose to guarantee additional bendability into the process of the sensing probe, to ensure internal routing in the case of misalignment between installation nozzle and the distribution of measuring points.
- **Additional accessories:** Components that can be ordered independently from the selected product configuration, such as junction boxes and transmitters, able to fit with all the already installed customer devices.

In general, the system measures the temperature profile inside the process environment by means of many sensors, jointed to a suitable process connection which ensures the right tightness levels. Externally, the extension cables (protected by the conduit) are wired into the junction box, which can be installed integrated or remote (optional).



Some of the options listed in this document may not be available in your country. Please contact your local Endress+Hauser representative.

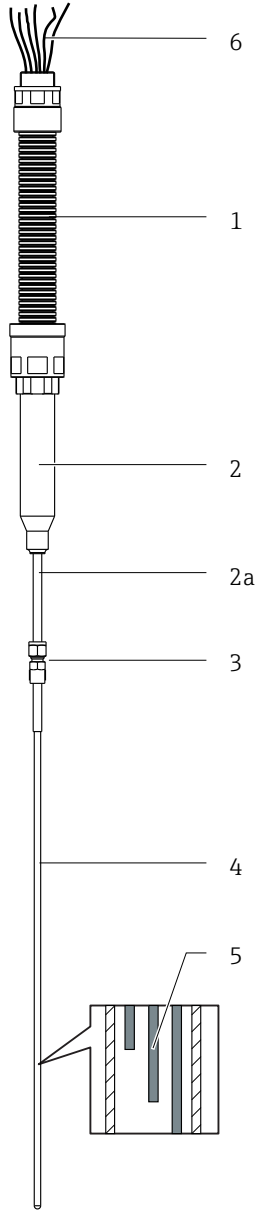
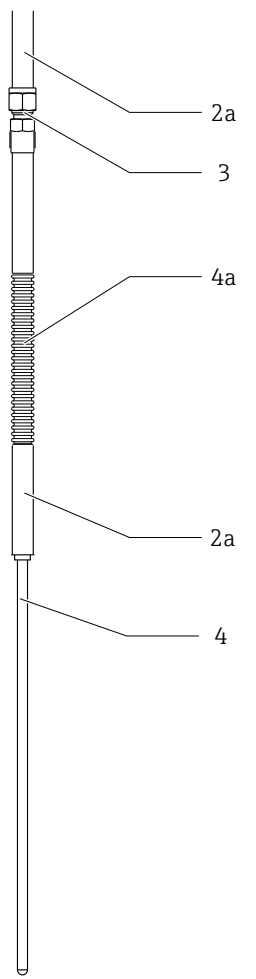

	Design	Description																
 <p>A0030865</p>	 <p>A0033069</p>	<table border="1"> <tr> <td data-bbox="762 257 911 470">1: Extension</td> <td data-bbox="911 257 1532 470">Flexible conduit used to protect the extension cables from environmental agents and phenomena (e.g. abrasion, humidity, salt conditions). Material:  <ul style="list-style-type: none"> <li>■ Polyamide</li> <li>■ Other materials on request</li> </ul>                     IP68 degree is guaranteed through the selected adapters.                 </td> </tr> <tr> <td data-bbox="762 470 911 537">2: Main bushing</td> <td data-bbox="911 470 1532 537">Used to seal and protect electrical junctions and to adjust immersion length.</td> </tr> <tr> <td data-bbox="762 537 911 638">2a: Reinforcing sleeve</td> <td data-bbox="911 537 1532 638"></td> </tr> <tr> <td data-bbox="762 638 911 873">3: Process connection</td> <td data-bbox="911 638 1532 873">High pressure compression fitting for the tightness between the process and the external environment, for a wide range of process fluids and different severe combination of temperature and pressure. In the case of a flange, the process connection is welded on the flange (standard). Other versions available on request. <b>Flange:</b> Different dimensions and sizes to meet specific standards (e.g. ASME, EN, DIN) and variable process requirements.</td> </tr> <tr> <td data-bbox="762 873 911 952">4: Thermowell</td> <td data-bbox="911 873 1532 952">Annealed tube used as protective sheath for sensing elements, inserted into the process</td> </tr> <tr> <td data-bbox="762 952 911 1041">4a: Flexible thermowell part</td> <td data-bbox="911 952 1532 1041">Annealed tube provided of an upper flexible part (corrugated conduit) to allow to reach different paths into the installation environment.</td> </tr> <tr> <td data-bbox="762 1041 911 1131">5: Inserts</td> <td data-bbox="911 1041 1532 1131">Not replaceable grounded or ungrounded thermocouple inserts with high accuracy measurement performance, long-term stability and reliability</td> </tr> <tr> <td data-bbox="762 1131 911 1478">6: Extension cables</td> <td data-bbox="911 1131 1532 1478">Not replaceable grounded or ungrounded thermocouple inserts with high accuracy measurement performance, long-term stability and reliability</td> </tr> </table>	1: Extension	Flexible conduit used to protect the extension cables from environmental agents and phenomena (e.g. abrasion, humidity, salt conditions). Material: <ul style="list-style-type: none"> <li>■ Polyamide</li> <li>■ Other materials on request</li> </ul> IP68 degree is guaranteed through the selected adapters.	2: Main bushing	Used to seal and protect electrical junctions and to adjust immersion length.	2a: Reinforcing sleeve		3: Process connection	High pressure compression fitting for the tightness between the process and the external environment, for a wide range of process fluids and different severe combination of temperature and pressure. In the case of a flange, the process connection is welded on the flange (standard). Other versions available on request. <b>Flange:</b> Different dimensions and sizes to meet specific standards (e.g. ASME, EN, DIN) and variable process requirements.	4: Thermowell	Annealed tube used as protective sheath for sensing elements, inserted into the process	4a: Flexible thermowell part	Annealed tube provided of an upper flexible part (corrugated conduit) to allow to reach different paths into the installation environment.	5: Inserts	Not replaceable grounded or ungrounded thermocouple inserts with high accuracy measurement performance, long-term stability and reliability	6: Extension cables	Not replaceable grounded or ungrounded thermocouple inserts with high accuracy measurement performance, long-term stability and reliability
1: Extension	Flexible conduit used to protect the extension cables from environmental agents and phenomena (e.g. abrasion, humidity, salt conditions). Material: <ul style="list-style-type: none"> <li>■ Polyamide</li> <li>■ Other materials on request</li> </ul> IP68 degree is guaranteed through the selected adapters.																	
2: Main bushing	Used to seal and protect electrical junctions and to adjust immersion length.																	
2a: Reinforcing sleeve																		
3: Process connection	High pressure compression fitting for the tightness between the process and the external environment, for a wide range of process fluids and different severe combination of temperature and pressure. In the case of a flange, the process connection is welded on the flange (standard). Other versions available on request. <b>Flange:</b> Different dimensions and sizes to meet specific standards (e.g. ASME, EN, DIN) and variable process requirements.																	
4: Thermowell	Annealed tube used as protective sheath for sensing elements, inserted into the process																	
4a: Flexible thermowell part	Annealed tube provided of an upper flexible part (corrugated conduit) to allow to reach different paths into the installation environment.																	
5: Inserts	Not replaceable grounded or ungrounded thermocouple inserts with high accuracy measurement performance, long-term stability and reliability																	
6: Extension cables	Not replaceable grounded or ungrounded thermocouple inserts with high accuracy measurement performance, long-term stability and reliability																	

The modular multipoint thermometer is characterized by the following possible main configurations:

- Linear configuration
- Flexible configuration

### 3.1.1 Number of inserts

Maximum number of inserts for every combination of thermowell and insert diameter

		Thermowell OD in mm (in)				
		3.2 (0.13)	6 (0.24)	6.35 (0.25)	8 (0.31)	9.5 (0.37)
Insert diameter in mm (in)	0.5 (0.02)	8	28	22	46 <sup>1)</sup>	59 <sup>1)</sup>
	0.8 (0.03)	3	15	12	24	30

		Thermowell OD in mm (in)				
		3.2 (0.13)	6 (0.24)	6.35 (0.25)	8 (0.31)	9.5 (0.37)
	1 (0.04)	2	10	8	18	22
	1.5 (0.06)	1	6	4	8	12

- 1) for this configuration the main bushing have to be specially engineered

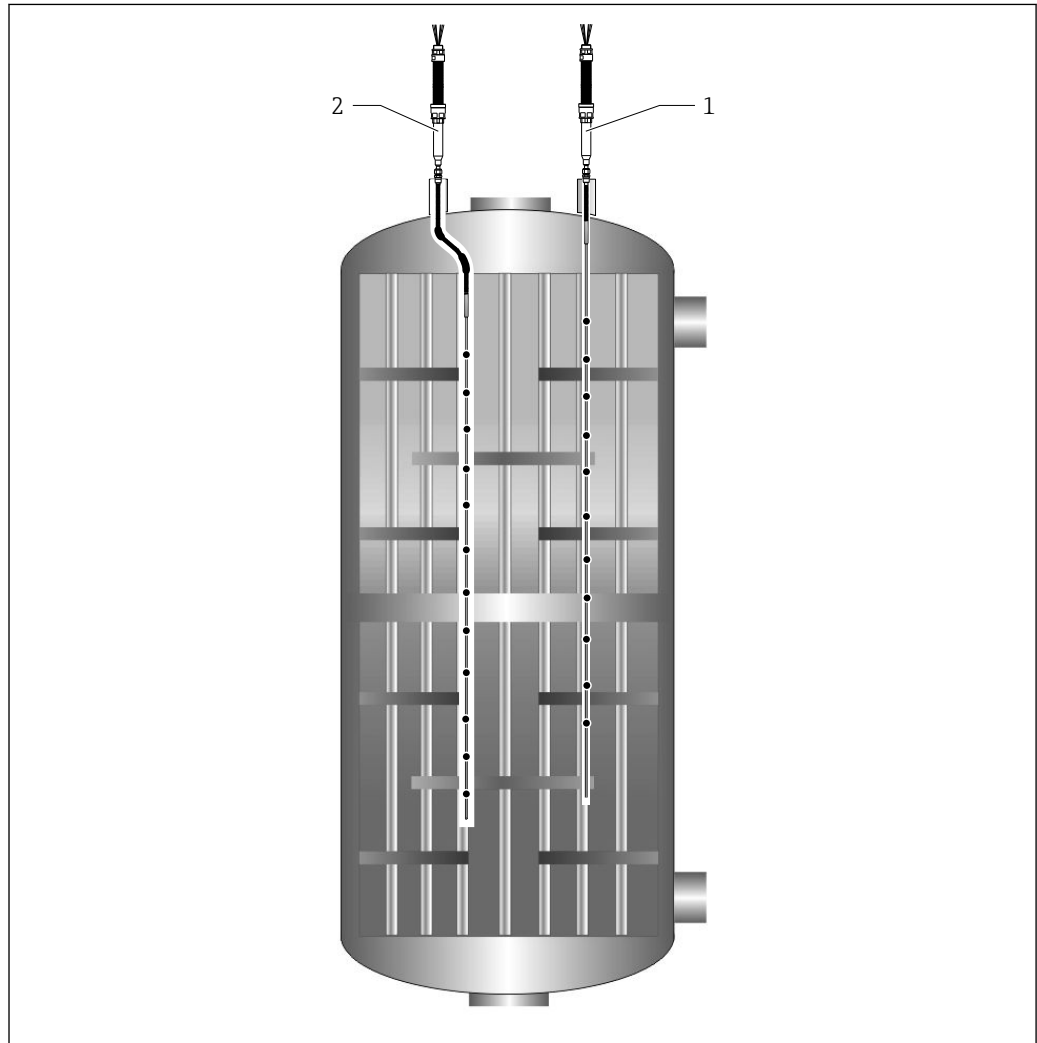

A0033848

- ☑ 1 Main configuration possibilities
- 1 Vertical installation with rigid configuration
- 2 Installation with flexible configuration

## 4 Incoming acceptance and product identification

### 4.1 Incoming acceptance

Before proceeding with the installation the following incoming acceptance procedures are suggested:

- Once the device is received it is always suggested to verify the integrity of the packaging and possible damages. Non-compliances should be immediately reported to the manufacturer. Damaged material shall not be installed: in these conditions, in fact, the manufacturer cannot guarantee the original safety requirements and cannot be considered responsible for any consequential effect.
- Compare the scope of delivery with the order content.
- Carefully remove all packaging/protection related to the freight.

### 4.2 Product identification

Nameplate specifications: The following nameplate layout serves to identify the specific product information from the serial number, design conditions, sizes, configuration to approvals:

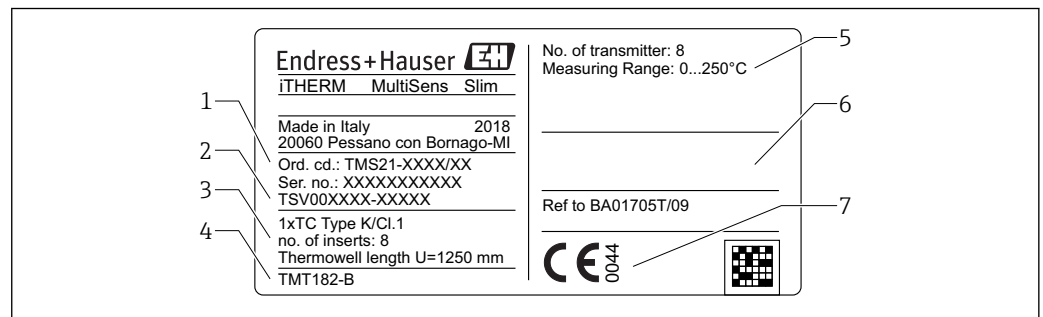

 2 Nameplate of the multipoint thermometer (example as landscape format)

Field number	Description	Examples
1	Order code and serial number	-
2	TSV drawing number	-
3	Sensor and product configuration	e.g. number of measuring points
4	Assembled transmitter	-
5	Sensor measuring temperature range	-
6	Approval number, hazardous area classification and Ex logo (if applicable) Safety instructions number (if applicable)	Does not apply to iTHERM multipoint family. Approvals refer to individual parts (e.g. junction box, cable gland, inserts, ...)
7	CE marking	-

Nameplate material:	Polyester foil or stainless steel
Nameplate lettering:	Direct laser printing
Fixing	Stuck on, glue-based

 Compare and check the data on the nameplate of the device against the requirements of the measurement point.

## 4.3 Storage and transport

Carefully remove each package and protection relative to the transportation packaging.

### NOTICE

#### Transportation of the device to the installation area

- ▶ Handle the device with care. Move the device by acting on the main bushing always ensuring that the probe length is properly constrained avoiding free movement under its own weight.
- ▶ During mounting phases avoid any load to welded or threaded parts, under the action of the weight of the device.
- ▶ When the device has to pass from horizontal to vertical position or vice versa, particular attention must be paid.
- ▶ Strictly avoid bumping the device against obstacles nearby the place where the device is to be installed.
- ▶ Avoid any friction between the device and surrounding bodies.
- ▶ Avoid twisting of extension cables.

 Pack the device for storage (and transportation) carefully in order to reliably protect it against impact. The original packaging provides the best protection.

For permitted storage temperature →  37.

## 5 Mounting

### 5.1 Mounting requirements

**⚠ WARNING**

**Failure to follow these installation guidelines could result in death or serious injury**

- ▶ Make sure only qualified personnel perform the installation.

**⚠ WARNING**

**Explosions could result in death or serious injury**

- ▶ If junction box is included, do not remove the junction box cover in explosive atmospheres when the circuit is live.
- ▶ Before connecting any additional electric and electronic device in an explosive atmosphere, make sure the instruments in the loop are installed in accordance with intrinsically safe or non incensive field wiring practices.
- ▶ Verify that the operating atmosphere of the transmitters is consistent with the appropriate hazardous locations certifications.
- ▶ All covers and threaded components must be fully engaged to meet explosion-proof requirements.

**⚠ WARNING**

**Process leaks could result in death or serious injury**

- ▶ Do not release screwed parts while in operation. Install and tighten the fittings before applying pressure.

**NOTICE**

**Additional loads and vibrations from other plant components can affect the operation of the sensor elements.**

- ▶ Is it not allowed to apply additional loads or external moments to the system coming from the connection with another system not foreseen from installation plan.
- ▶ The system is not suitable for being installed in locations where vibrations are present. The deriving loads can undermine the sealing of the junctions and damage the operation of the sensing elements.
- ▶ It will be care of the final user to verify the installation of suitable devices in order to avoid the overcoming of the admitted limits.
- ▶ For the environment conditions please refer to the technical data →  37

### 5.2 Mounting the assembly

The following instructions have to be followed for the proper installation of the device.

1.

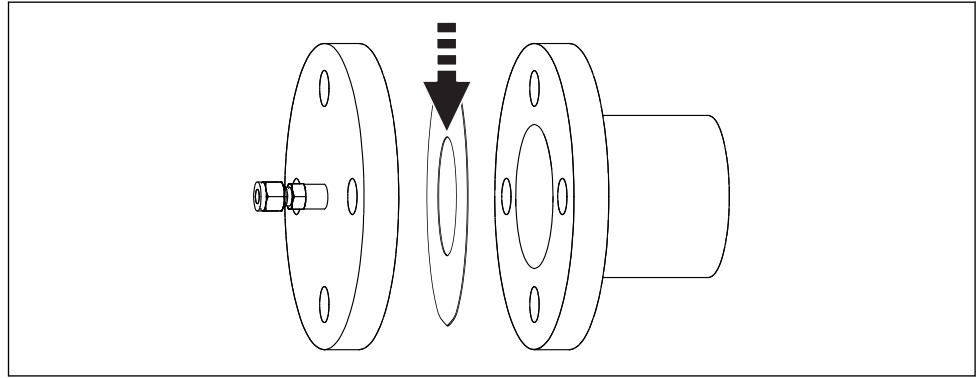

A0033274

Place the gasket between the flanged nozzle and the flange of the device provided with a compression fitting (after checking the cleanliness of gasket seats on the flanges). If the process connection does not include a flange place the compression fitting on the foreseen connection and tight or weld it.

2.

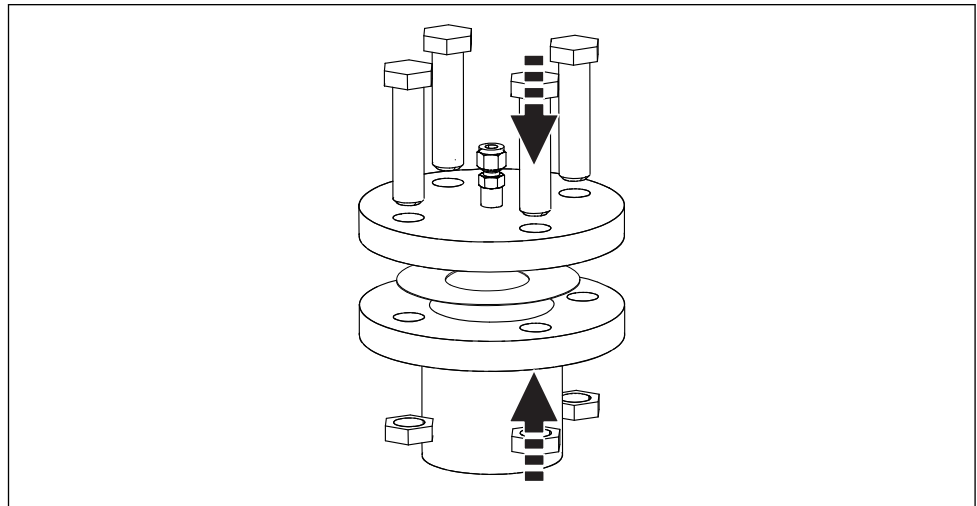

A0033275

Start the bolts insertion through the flanges' holes and screw them with the nuts without complete tightness.

3.

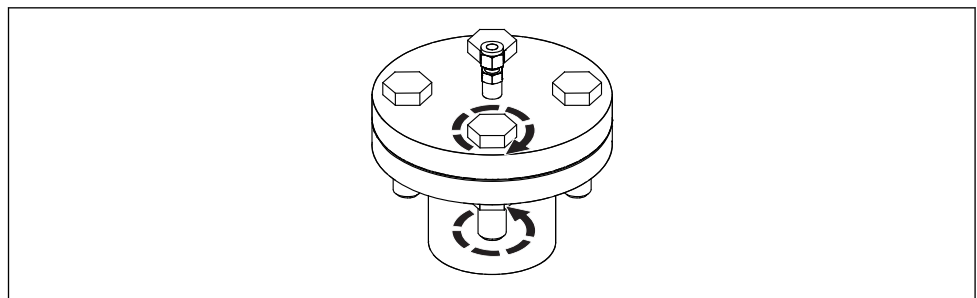

A0033276

Complete the bolts insertion through the flanges' holes and tighten them with crossed method by means of an appropriate equipment and method (i.e. controlled tensioning).

4.

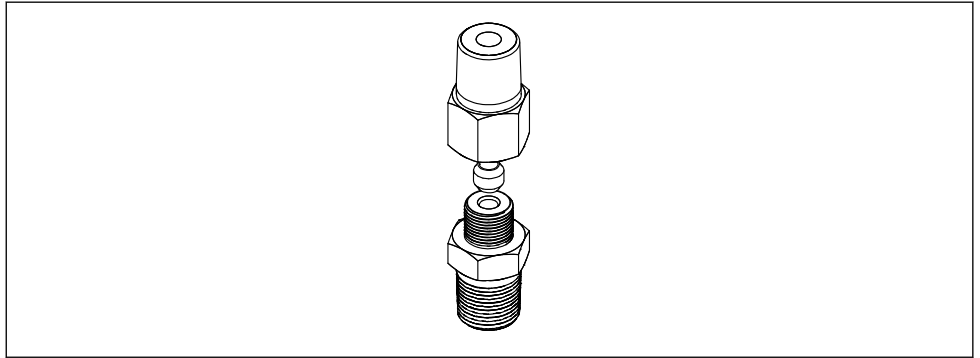

A0033277

Check if the compression fitting is provided with all the necessary sealing metallic gaskets.

5.

Approach the device to the nozzle, inserting the probe through the compression fitting avoiding deformation of both thermowell and reinforcing sleeve.

6.

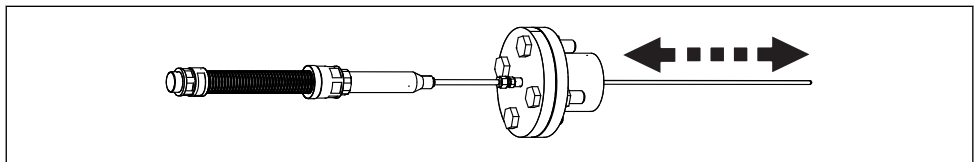

A0033278

Adjust the immersion length of the probe by sliding the measuring system along the reinforcing sleeve.

7.

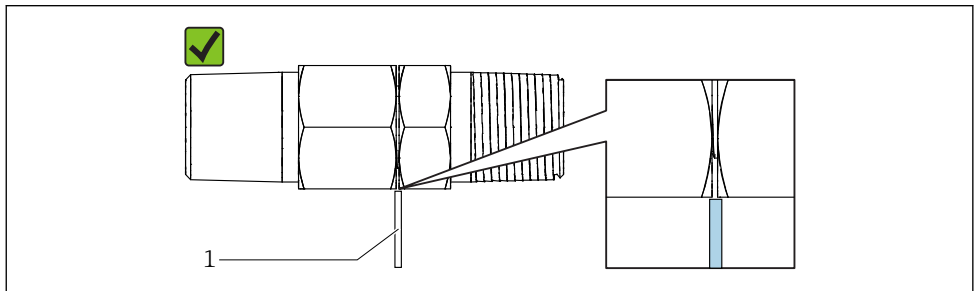

A0033279

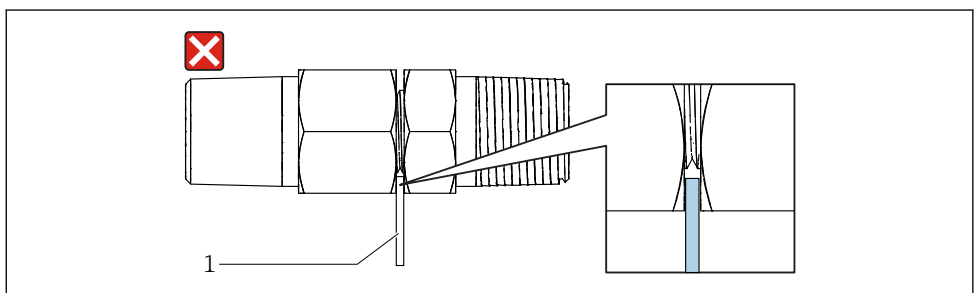

A0033280

Tighten the compression fitting while maintaining the measuring system steady and ensuring the sealing is done on the reinforcing sleeve. If the gauge (1) does not fit into the gap, the fitting is sufficiently tightened. If the gauge fits into the gap, additional tightening is required.

8.

When installing an existing thermowell, an internal inspection of the thermowell is recommended to check if any internal encumbrance is present before starting with the insertion activities of the whole device. While installing the measurement system, avoid any friction during installation, specifically avoid spark generation. When accessories like spacers and/or centered parts are provided make sure that no distortions occur and the original geometry and position is maintained.

9. When the installation is in direct contact with the process, ensure that any applied external load does not generate deformations and strains on the probe and on the sealing welding.
10. Introduce the extension (or compensating) cables through the cable glands of the junction box.
11. When the complete path of the extension conduit is defined, fix it permanently from the main bushing to the junction box ensuring axial movement. Remark: when bending the conduit observe a minimum radius of 1.5 times its external diameter.
12. Tighten the cable glands on the junction box.
13. Connect the compensating cables to the terminals or to the transmitters of the junction box following the wiring instructions provided, ensuring the right matching between the cable tag numbers and the terminal tag numbers. Note: The electrical connection must be made with the correct compensating cable.

#### NOTICE

**After mounting, perform a few simple checks on the thermometric system installed.**

- ▶ Check the tightness of the threaded connections. If any part is loose, tighten it applying the proper torque.
- ▶ Check for correct wiring, test the electrical continuity of the thermocouples (warming up the thermocouples' hot junction, when feasible) and then verify the absence of short circuits.

### 5.3 Post-mounting check

*Before commissioning the measuring system make sure that all final checks have been carried out:*

Device conditions and specifications	
Is the device undamaged (visual inspection)?	<input type="checkbox"/>
Do the ambient conditions match the device specification? For example: <ul style="list-style-type: none"> <li>▪ Ambient temperature</li> <li>▪ Proper conditions</li> </ul>	<input type="checkbox"/>
Are the threaded components undeformed?	<input type="checkbox"/>
Are the gaskets and sealing components not permanently deformed?	<input type="checkbox"/>
Installation	
Is the equipment aligned with the nozzle axis?	<input type="checkbox"/>
Are the gasket seats of flanges clean? (If applicable)	<input type="checkbox"/>
Is the coupling between the flange and its counter flange reached? (If applicable)	<input type="checkbox"/>
Is the probe straight and geometry maintained?	<input type="checkbox"/>
Is the flexible conduit undamaged and not twisted?	<input type="checkbox"/>
Are the bolts completely inserted in the flange? (If applicable, make sure the flange is completely attached to the nozzle.)	<input type="checkbox"/>
Does the compression fitting have all the sealing components?	<input type="checkbox"/>
Is the compression fitting properly tightened on the reinforcing sleeve?	<input type="checkbox"/>
Are the cable glands tightened on the extension cables? (If applicable)	<input type="checkbox"/>
Are the extension cables connected to the junction box terminals or transmitters? (If applicable)	<input type="checkbox"/>



## 6 Wiring





### CAUTION

**Failure to observe this may result in destruction of parts of the electronics.**

- ▶ Switch off power supply before installing or connecting the device.
- ▶ When installing Ex-approved devices in a hazardous area please take special note of the instructions and connection schematics in the respective Ex documentation added to these Operating Instructions. The local Endress+Hauser representative is available for assistance if required.

 When wiring to a transmitter also observe the wiring instructions in the enclosed Brief Operating manuals of the relevant transmitter.

For wiring the device proceed as follows:

1. Open the housing cover on the junction box.
2. Open the cable glands on the sides of the junction box. →  13
3. Feed the cables through the opening in the cable glands.
4. Connect the cables as shown on →  17
5. On completion of the wiring, screw the screw terminals tight. Tighten the cable glands again. In doing so, also pay particular attention to →  21. Close the housing cover again.
6. In order to avoid connection errors always take note of the hints given in the post connection check! →  22

### 6.1 Quick wiring guide

Terminal assignment

#### NOTICE

**Destruction or malfunction of parts of the electronics through ESD - electrostatic discharge.**

- ▶ Take measures to protect the terminals from electrostatic discharge.

 To avoid incorrect measuring values an extension or compensation cable for direct wiring of thermocouple and RTD sensors for the signal transmission has to be used. The polarity indication on the respective terminal block and the wiring scheme has to be observed.

The planning and the installation of the bus connection cables of the plant is not to be concerned of the manufacturer of the device. Therefore the manufacturer cannot be considered to be responsible for possible damages due to the choice of materials that are not suitable for that application or to a faulty installation.

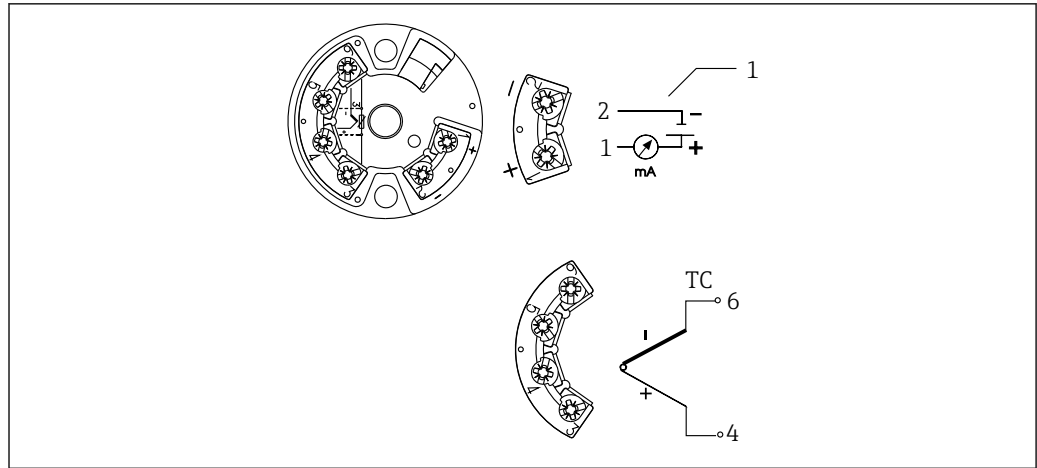

A0033074

3 Wiring diagram of the single sensor input head transmitters (TMT18x)

1 Power supply head transmitter and analog output 4 to 20 mA, or bus connection

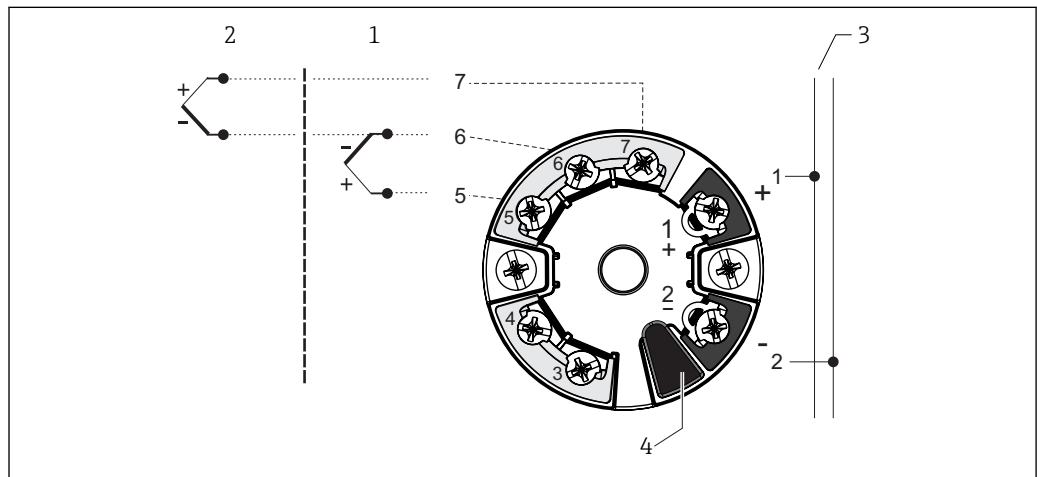

A0033075

4 Wiring diagram of the dual sensor input head transmitters (TMT8x)

- 1 Sensor input 1
- 2 Sensor input 2
- 3 Bus connection and supply voltage
- 4 Display connection

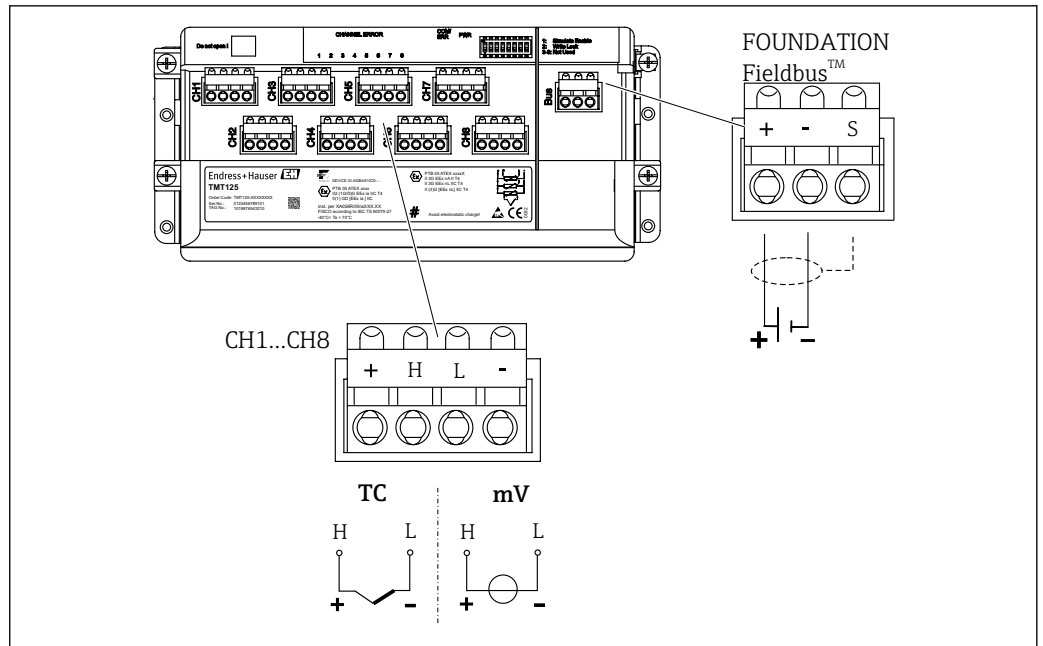

A0033071

5 Wiring diagram of multi-channel transmitter

*Thermocouple cable colors*

According to IEC 60584	According to ASTM E230
<ul style="list-style-type: none"> <li>▪ Type E: Violet (+), white (-)</li> <li>▪ Type J: Black (+), white (-)</li> <li>▪ Type K: Green (+), white (-)</li> <li>▪ Type N: Pink (+), white (-)</li> </ul>	<ul style="list-style-type: none"> <li>▪ Type E: Purple (+), red (-)</li> <li>▪ Type J: White (+), red (-)</li> <li>▪ Type K: Yellow (+), red (-)</li> </ul>

## 6.2 Connecting the sensor cables

**i** Each sensor is marked with an individual TAG number. As default configuration, all wires are always connected to the installed transmitters or terminals (when applicable).

The wiring is done in consecutive order, which means that the input channel(s) of transmitter no. 1 are connected to the insert wires starting from insert no. 1. Transmitter no. 2 is not used until all channels of transmitter no. 1 are fully connected. The wires of each insert are marked with consecutive numbers starting from 1. If double sensors are used the internal marking has a suffix to distinguish the two sensors, e.g. 1A and 1B for double sensors in the same insert or measuring point no. 1.

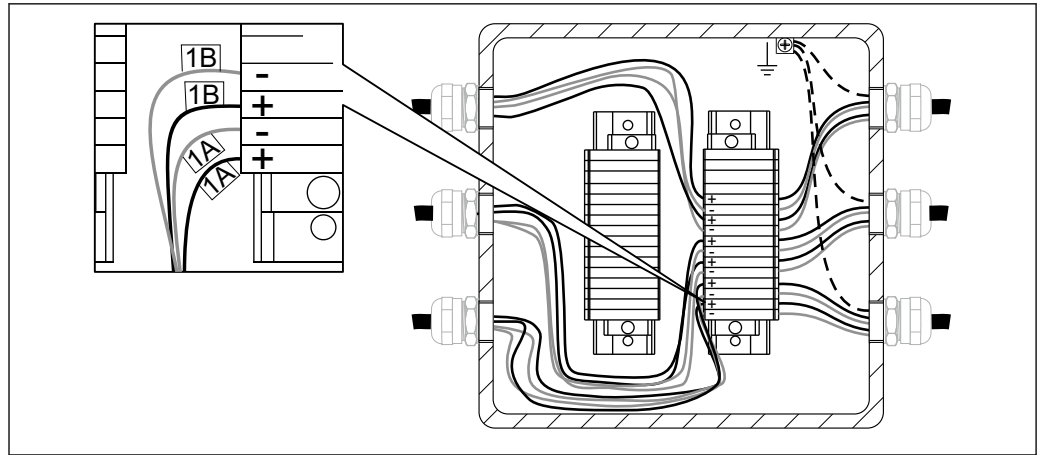

A0033288

6 Direct wiring on the mounted terminal block. Example for the internal sensor wires marking with 2 x TC sensors in insert no. 1.

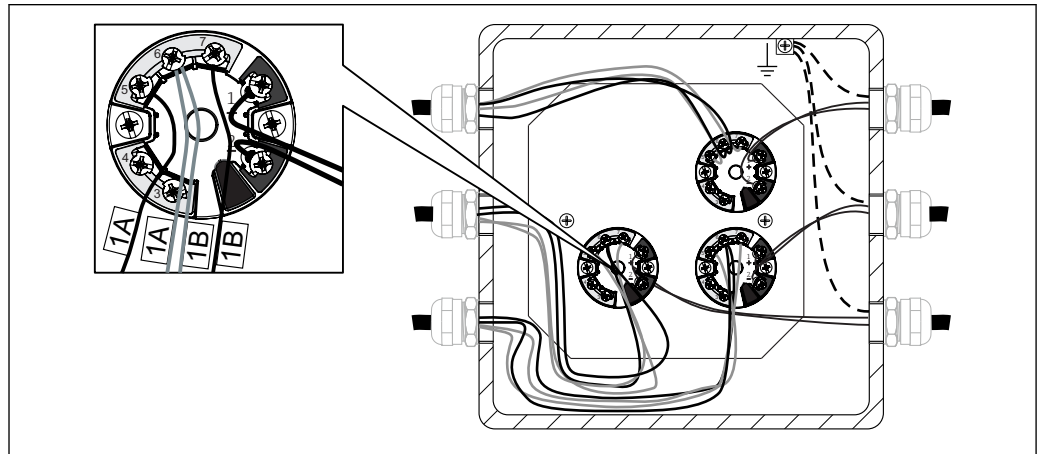

A0033289

7 Mounted and wired head transmitter. Example for the internal sensor wires marking with 2 x TC

Sensor type	Transmitter type	Wiring rule
1 x TC	<ul style="list-style-type: none"> <li>▪ Single input (one channel)</li> <li>▪ Double input (two channel)</li> <li>▪ Multi-channel input (8 channel)</li> </ul>	<ul style="list-style-type: none"> <li>▪ 1 Head transmitter per insert</li> <li>▪ 1 Head transmitter for 2 inserts</li> <li>▪ 1 Multi-channel transmitter for 8 inserts</li> </ul>
2 x TC	<ul style="list-style-type: none"> <li>▪ Single input (one channel)</li> <li>▪ Double input (two channel)</li> <li>▪ Multi-channel input (8 channel)</li> </ul>	<ul style="list-style-type: none"> <li>▪ Not available, wiring excluded</li> <li>▪ 1 Head transmitter per insert</li> <li>▪ 1 Multi-channel transmitter for 4 inserts</li> </ul>

### 6.3 Connecting the power supply and signal cables

#### Cable specification

- A shielded cable is recommended for fieldbus communication. Take the plant grounding concept into consideration.
- The terminals for connecting the signal cable (1+ and 2-) are protected against reverse polarity.
- Conductor cross-section:
  - Max 2.5 mm<sup>2</sup> (14 AWG) for screw terminals
  - Max 1.5 mm<sup>2</sup> (16 AWG) for spring terminals

Always observe the general procedure on → 17.

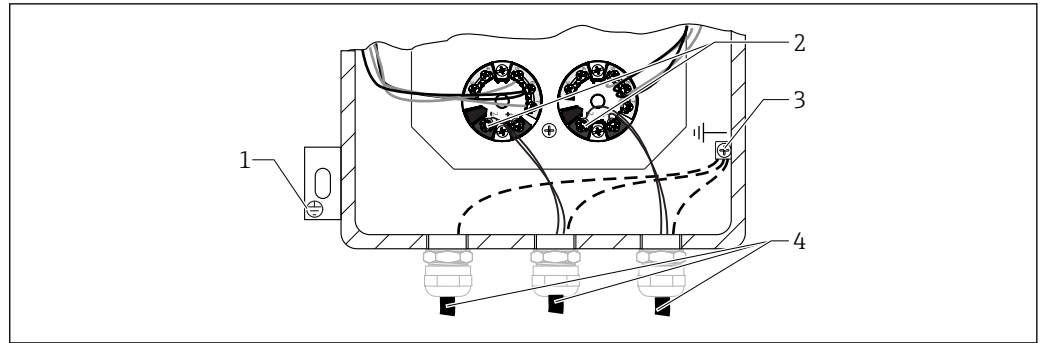

A0033290

8 Connecting the signal cable and power supply to the installed transmitter

- 1 External ground terminal
- 2 Terminals for signal cable and power supply
- 3 Internal ground terminal
- 4 Shielded signal cable, recommended for fieldbus connection

## 6.4 Shielding and grounding

**i** For any specific electrical shielding and grounding regarding the transmitter wiring please refer to the appropriate operating manual of the installed transmitter.

Where applicable, national installation regulations and guidelines must be observed during the installation! Where there are large differences in potential between the individual grounding points, only one point of the shielding is connected directly with the reference ground. In systems without potential equalization, therefore, cable shielding of fieldbus systems should only be grounded on one side, for example at the supply unit or at safety barriers.

### NOTICE

**If the shielding of the cable is grounded at more than one point in systems without potential matching, power supply frequency equalizing currents can occur that damage the signal cable or have a serious effect on signal transmission.**

- In such cases the shielding of the signal cable is to be grounded on only one side, i.e. it must not be connected to the ground terminal of the housing (terminal head, field housing). The shield that is not connected should be insulated!

## 6.5 Degree of protection

In order to fulfil the degree of protection after installation or service, the following points must be taken into consideration: → 9, 22

- The housing seals must be clean and undamaged before they are replaced in the sealing rebate. If they are found to be too dry, they should be cleaned or even replaced.
- All housing screws and covers must be tightened.
- The cables and conduit used for connection must be of the correct specified outside diameter (e.g. M20 x 1.5, cable diameter from 0.315 to 0.47 in; 8 to 12 mm).
- Tighten cable gland.
- Lock adapter by means of the provided clip.
- Loop the cable or conduit before placing into the entry ("Water sack"). This means that any moisture that may form cannot enter the gland. Install the device so that the cable or conduit entries are not facing upwards.
- Entries not used are to be blanked off using the blanking plates provided.

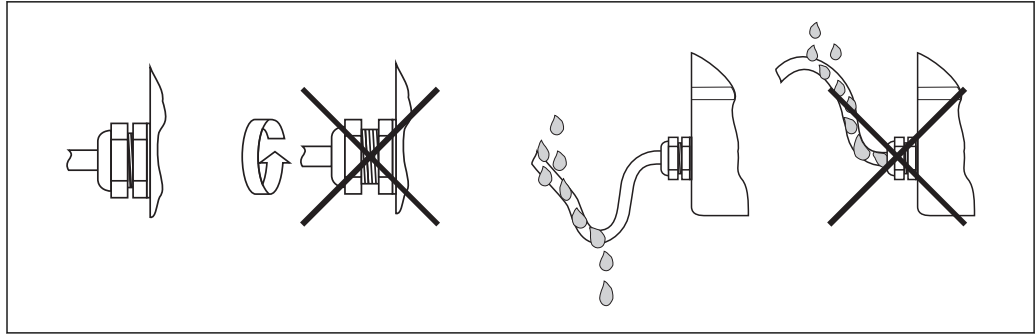

A0011260

9 Connection hints to maintain IP protection

## 6.6 Post-connection check

Is the device undamaged (internal equipment inspection)?	<input type="checkbox"/>
<b>Electrical connection</b>	
Does the supply voltage match the specifications on the nameplate?	<input type="checkbox"/>
Do the cables have adequate strain relief?	<input type="checkbox"/>
Are the power supply and signal cables correctly connected? → 17	<input type="checkbox"/>
Are all the screw terminals well tightened and have the connections of the spring terminals been checked?	<input type="checkbox"/>
Are all the cable glands installed, tightened and sealed?	<input type="checkbox"/>
Are all the housing covers installed and tightened?	<input type="checkbox"/>
Does the marking of the terminals and cables match?	<input type="checkbox"/>
Is the electrical continuity of the thermocouple verified?	<input type="checkbox"/>

## 7 Commissioning

### 7.1 Preliminaries

Set-up guidelines of Standard, Extended and Advanced Commissioning for Endress+Hauser instruments in order to guarantee the function of the instrument according to:

- Endress+Hauser operating manual
- Customer set up specification, and/or
- Application conditions, when applicable under process conditions

Both the operator and the person responsible for the process should be informed that a commissioning job will be carried out, observing the following actions:

- If applicable, before disconnecting any sensor that is attached to the process, determine what chemical or fluid is being measured (observe safety data sheet).
- Be aware of the temperature and pressure conditions.
- Never open a process fitting or loosen flange bolts before you have confirmed it is safe to do so.
- Be sure not to disturb the process when disconnecting inputs/outputs or when simulating signals.
- Ensure our tools, equipment and the customer process are protected from cross contamination. Consider and plan necessary cleaning steps.
- When commissioning requires chemicals (e.g. as reagents for standard operation or for cleaning purposes), always follow and observe the safety regulations.

#### 7.1.1 Reference documents



- Endress+Hauser Standard Operating Procedure for Health and Safety (see documentation code: BP01039H)
- Operating Manual of relevant tools and equipment to perform the commissioning job.
- Relevant Endress+Hauser Service Documentation (operating manual, work instructions, service info, service manual, etc.).
- Calibration certificates of the quality relevant equipment if available.
- If applicable, safety data sheet.
- Customer specific documents (safety instructions, setup points, etc.).

#### 7.1.2 Tools and equipment

Multimeter and instrument related configuration tools as necessary from the above mentioned action list.

### 7.2 Function check

Before commissioning the device make sure that all final checks have been carried out

- "Post-mounting check" checklist →  16
- "Post-connection check" checklist →  22

The commissioning should be performed according to our commissioning segmentation (Standard, Extended and Advanced).

#### 7.2.1 Standard commissioning

Visual inspection of device

1. Check the instrument(s) for damage which may have been caused during transport/shipping or mounting/wiring
2. Check that the installation is done according to the operating manual

3. Check that the wiring is done according to the operating manual and the local regulations (e.g. grounding)
4. Check the dust/water tightness of the instrument(s)
5. Check safety precautions (e.g., radiometric measurements)
6. Power up the instrument(s)
7. Check the alarm list if applicable

#### Environmental conditions

1. Check that the environmental conditions are appropriate for the instrument(s): Ambient temperature, humidity (ingress protection IPxx), vibrations, hazardous areas (Ex, Dust-Ex), RFI/EMC, sun protection, etc.
2. Check access to the instrument(s) for utilization and maintenance

#### Configuration parameters

- ▶ Configure the instrument(s) according to the Operating Manual with the parameters specified by the customer or mentioned on the design specification

#### Output signal value check

- ▶ Check and confirm that the local display and the output signals of the instrument(s) conform with the customer's display

### 7.2.2 Extended commissioning

In addition to the steps of Standard Commissioning, the following should be additionally completed:

#### Instrument Conformity

1. Check the received instrument(s) with the purchase order or design specification including accessories, documentation and certificates
2. Check Software Version (e.g. application software such as "Batching") when provided
3. Check that the documentation has the correct issue and version

#### Functional test

1. Test of the instrument outputs, including switching points, auxiliary inputs/outputs with the internal or an external simulator (e.g. FieldCheck)
2. Compare the measuring data/results with a reference from the customer. (e.g. laboratory result in case of an analyzer, weight scale in the case of a batching application, etc.)
3. Adjust the instrument(s) if necessary and as described in the operating manual

### 7.2.3 Advanced commissioning

The Advanced Commissioning provides a loop test in addition to the steps covered in the Standard and Extended Commissioning.

#### Loop test

1. Simulate a minimum of 3 output signals from the instrument(s) to the control room
2. Read out/note the simulated and indicated values and check for linearity



## 7.3 Switching on the device

Once the final checks have been successfully completed, it is time to switch on the supply voltage. Afterwards the multipoint thermometer is operational. If there are Endress+Hauser temperature transmitter in use, please refer to the enclosed Brief Operating Instructions for commissioning.

# 8 Diagnostics and troubleshooting

## 8.1 General troubleshooting

### NOTICE

#### Repair of parts of the device

- ▶ In the event of a serious fault, a measuring device might have to be replaced. In the case of replacement see section 'Return' →  26.
- ▶ It is always important to check the connection between the cables and terminals, in order to guarantee the proper strain relief to the cables, and the tightening and the sealing of the screw terminals.

Before commissioning the measuring system make sure that all final checks have been carried out:

- Follow the checklist in section 'Post-mounting check' →  16
- Follow the checklist in section 'Post-connection check' →  22

If transmitters are used, please refer to the documentation of the transmitter installed for diagnostic and troubleshooting procedures →  43.

## 9 Repair

### 9.1 General notes

The accessibility around the device for maintenance has to be guaranteed. Each component that is part of the device must be – in the case of replacement – replaced by an original spare part of Endress+Hauser which guarantees the same characteristics and performance. To ensure continued operational safety and reliability it is suggested to carry out repairs on the device only if they are expressly permitted by Endress+Hauser, observing federal/national regulations pertaining to repair of an electrical device.

### 9.2 Spare parts

When ordering spare parts, please specify the serial number of the unit!

Spare parts of the Multipoint thermometer assembly are:

- Conduit and adapters
- Cable glands, transmitters or electrical terminals, if provided
- Other accessories when applied and replaceable

### 9.3 Endress+Hauser services

Service	Description
Certifications	Endress+Hauser is able to fulfill requirements belonging to the design, product manufacturing, tests and commissioning according to specific approvals by handling or supplying individual certified components and by checking the integration on the whole system.
Maintenance	All Endress+Hauser systems are designed for an easy maintenance due to a modular design, allowing the replacement of old or wear out parts. Standardized parts ensure fast reaction for maintenance.
Calibration	Endress+Hauser's range of calibration services covers on-site verification tests, accredited laboratory calibrations, certificates and traceability to ensure compliance.

### 9.4 Return

The measuring device must be returned if it is need of repair or a factory calibration, or if the wrong measuring device has been delivered or ordered. Legal specifications require Endress+Hauser, as an ISO-certified company, to follow certain procedures when handling products that are in contact with the medium.

To ensure safe, swift and professional device returns, please refer to the procedure and conditions for returning devices provided on the Endress+Hauser website at <http://www.endress.com/support/return-material>

### 9.5 Disposal

#### 9.5.1 Removing the measuring device

1. Switch off the device.

**2. ⚠ WARNING****Danger to persons from process conditions.**

- ▶ Beware of hazardous process conditions such as pressure in the measuring device, high temperatures or aggressive fluids.

Carry out the mounting and connection steps from the chapters "Mounting the measuring device" and "Connecting the measuring device" in the logically reverse sequence. Observe the safety instructions.

## 9.5.2 Disposing of the measuring device

**⚠ WARNING****Danger to personnel and environment from fluids that are hazardous to health.**

- ▶ Ensure that the measuring device and all cavities are free of fluid residues that are hazardous to health or the environment, e.g. substances that have permeated into crevices or diffused through plastic.

Observe the following notes during disposal:

- Observe valid federal/national regulations.
- Ensure proper separation and reuse of the device components.

## 10 Accessories

Various accessories, which can be ordered with the device or subsequently from Endress+Hauser, are available for the device. Detailed information on the order code in question is available from your local Endress+Hauser sales center.

### 10.1 Device-specific accessories

Accessories	Description
Junction box	The junction box is suited for chemical agents environments. Sea water corrosion resistance and extreme temperature variation stability is guaranteed. Ex-e, Ex-i terminals can be generally installed.
Transmitter	Head transmitters <ul style="list-style-type: none"> <li>▪ PC programmable head transmitter</li> <li>▪ With HART<sup>®</sup>-, PROFIBUS<sup>®</sup> PA or FOUNDATION Fieldbus<sup>™</sup> communication protocol</li> </ul> 8-channel DIN rail transmitter with FOUNDATION Fieldbus <sup>™</sup> communication protocol
Pads, clips, spacers	<ul style="list-style-type: none"> <li>▪ Pads and clips: in order to fix the multipoint thermometer along its immersion length.</li> <li>▪ Spacer: Used in presence of an existing thermowell in order to guarantee the centering.</li> </ul>
Specific extension for on-board junction box	When the junction box cannot be remotely installed, it has to be configured on-board at the multipoint thermometer. Therefore, a specific extension design has to be provided. This design is available on request only for flanged process connection.

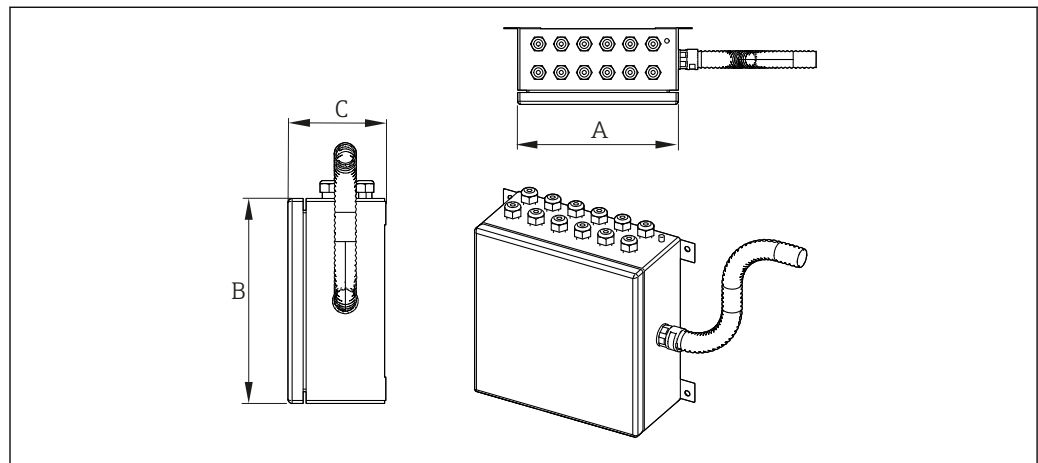

A0030866

10 Junction box as accessory for remote installation

Possible junction box dimensions (A x B x C) in mm (in):

		A	B	C
Stainless Steel	Min.	170 (6.7)	170 (6.7)	130 (5.1)
	Max.	500 (19.7)	500 (19.7)	240 (9.5)
Aluminium	Min.	100 (3.9)	150 (5.9)	80 (3.2)
	Max.	330 (13)	500 (19.7)	180 (7.1)



Maximal possible number <sup>1)</sup> of head transmitters/terminal blocks:





Junction box size	N° of TMT8x/18x	N° of TMT125	N° of terminal blocks
150x150x100	2	0	12
200x200x160	4	0	20
280x280x160	6	1	60
270x350x130	12	2	90
350x350x160	12	2	135
380x380x160	20	2	159
350x500x160	28	4	225
500x500x160	42	6	360

- 1) Thermal dissipation and so maximum number of transmitters has to be checked according to maximum ambient temperature.

Type of specification	Junction box	Cable glands
Material	AISI 316 / aluminum	NiCr Plated brass AISI 316 / 316L
Ingress protection (IP)	IP66/67	IP66
Ambient temperature range	-50 to +60 °C (-58 to +140 °F)	-52 to +110 °C (-61.1 to +140 °F)
Approvals	IEC-EX, ATEX, UL, FM, CSA, NEPSI, EAC-EX approval for use in hazardous area approval	-
Marking	II 2 GD Ex e IIC Gb Ex ia Ga IIC T Ex tb IIIC UL913 FM3610 CSA C22.2 No. 157 Class 1, Division 1, Groups B, C, D T6/T5/T4	-
Cover	Hinged	-
Maximum sealing diameter	-	6 to 12 mm (0.24 to 0.47 in)

## 10.2 Communication-specific accessories

Configuration kit TXU10	Configuration kit for PC-programmable transmitter with setup software and interface cable for PC with USB port Order code: TXU10-xx
Commubox FXA195 HART	For intrinsically safe HART communication with FieldCare via the USB interface.  For details, see "Technical Information" TI00404F
Commubox FXA291	Connects Endress+Hauser field devices with a CDI interface (= Endress+Hauser Common Data Interface) and the USB port of a computer or laptop.  For details, see "Technical Information" TI00405C
HART Loop Converter HMX50	Is used to evaluate and convert dynamic HART process variables to analog current signals or limit values.  For details, see "Technical Information" TI00429F and Operating Instructions BA00371F

Wireless HART adapter SWA70	<p>Is used for the wireless connection of field devices. The WirelessHART adapter can be easily integrated into field devices and existing infrastructures, offers data protection and transmission safety and can be operated in parallel with other wireless networks with minimum cabling complexity.</p> <p> For details, see Operating Instructions BA061S</p>
Fieldgate FXA320	<p>Gateway for the remote monitoring of connected 4-20 mA measuring devices via a Web browser.</p> <p> For details, see "Technical Information" TI00025S and Operating Instructions BA00053S</p>
Fieldgate FXA520	<p>Gateway for the remote diagnostics and remote configuration of connected HART measuring devices via a Web browser.</p> <p> For details, see "Technical Information" TI00025S and Operating Instructions BA00051S</p>
Field Xpert SFX100	<p>Compact, flexible and robust industry handheld terminal for remote configuration and for obtaining measured values via the HART current output (4-20 mA).</p> <p> For details, see Operating Instructions BA00060S</p>

### 10.3 Service-specific accessories

Accessories	Description
Applicator	<p>Software for selecting and sizing Endress+Hauser measuring devices:</p> <ul style="list-style-type: none"> <li>Calculation of all the necessary data for identifying the optimum measuring device: e.g. pressure loss, accuracy or process connections.</li> <li>Graphic illustration of the calculation results</li> </ul> <p>Administration, documentation and access to all project-related data and parameters over the entire life cycle of a project.</p> <p>Applicator is available:</p> <ul style="list-style-type: none"> <li>Via the Internet: <a href="https://wapps.endress.com/applicator">https://wapps.endress.com/applicator</a></li> <li>On CD-ROM for local PC installation.</li> </ul>
W@M	<p>Life cycle management for your plant</p> <p>W@M supports you with a wide range of software applications over the entire process: from planning and procurement, to the installation, commissioning and operation of the measuring devices. All the relevant device information, such as the device status, spare parts and device-specific documentation, is available for every device over the entire life cycle.</p> <p>The application already contains the data of your Endress+Hauser device. Endress+Hauser also takes care of maintaining and updating the data records.</p> <p>W@M is available:</p> <ul style="list-style-type: none"> <li>Via the Internet: <a href="http://www.endress.com/lifecyclemanagement">www.endress.com/lifecyclemanagement</a></li> <li>On CD-ROM for local PC installation.</li> </ul>
FieldCare	<p>FDT-based plant asset management tool from Endress+Hauser.</p> <p>It can configure all smart field units in your system and helps you manage them. By using the status information, it is also a simple but effective way of checking their status and condition.</p> <p> For details, see Operating Instructions BA00027S and BA00059S</p>

# 11 Technical data

## 11.1 Input

### 11.1.1 Measured variable

Temperature (temperature linear transmission behavior)

## 11.2 Output

### 11.2.1 Output signal

Generally, the measured value can be transmitted in one of two ways:

- Directly-wired sensors - sensor measured values forwarded without a transmitter.
- Via all common protocols by selecting an appropriate Endress+Hauser iTEMP temperature transmitter. All the transmitters listed below are mounted directly in the junction box and wired with the sensory mechanism.

### 11.2.2 Family of temperature transmitters

Thermometers fitted with iTEMP transmitters are an installation-ready complete solution to improve temperature measurement by significantly increasing accuracy and reliability, when compared to direct wired sensors, as well as reducing both wiring and maintenance costs.

#### **PC programmable head transmitters**

They offer a high degree of flexibility, thereby supporting universal application with low inventory storage. The iTEMP transmitters can be configured quickly and easily at a PC. Endress+Hauser offers free configuration software which can be downloaded from the Endress+Hauser Website. More information can be found in the Technical Information.

#### **HART® programmable head transmitters**

The transmitter is a 2-wire device with one or two measuring inputs and one analog output. The device not only transfers converted signals from resistance thermometers and thermocouples, it also transfers resistance and voltage signals using HART® communication. It can be installed as an intrinsically safe apparatus in Zone 1 hazardous areas and is used for instrumentation in the terminal head (flat face) as per DIN EN 50446. Swift and easy operation, visualization and maintenance by PC using operating software, Simatic PDM or AMS. For more information, see the Technical Information.

#### **PROFIBUS® PA head transmitters**

Universally programmable head transmitter with PROFIBUS® PA communication. Conversion of various input signals into digital output signals. High accuracy over the complete ambient temperature range. Swift and easy operation, visualization and maintenance using a PC directly from the control panel, e. g. using operating software, Simatic PDM or AMS. For more information, see the Technical Information.

#### **FOUNDATION Fieldbus™ head transmitters**

Universally programmable head transmitter with FOUNDATION Fieldbus™ communication. Conversion of various input signals into digital output signals. High accuracy over the complete ambient temperature range. Swift and easy operation, visualization and maintenance using a PC directly from the control panel, e.g. using operating software such as ControlCare from Endress+Hauser or NI Configurator from National Instruments. For more information, see the Technical Information.

Advantages of the iTEMP transmitters:

- Dual or single sensor input (optionally for certain transmitters)
- Unsurpassed reliability, accuracy and long-term stability in critical processes
- Mathematical functions
- Monitoring of the thermometer drift, sensor backup functionality, sensor diagnostic functions
- Sensor-transmitter matching for dual sensor input transmitter, based on Callendar/Van Dusen coefficients

### 11.3 Power supply

-  Electrical connecting cables must be smooth, corrosion resistant, easy to be cleaned and inspected, robust against mechanical stresses, no-humidity sensitivity.
- Grounding or shielding connections are possible via ground terminals on the junction box.

#### 11.3.1 Wiring diagrams

Wiring diagrams for TC and RTD connection

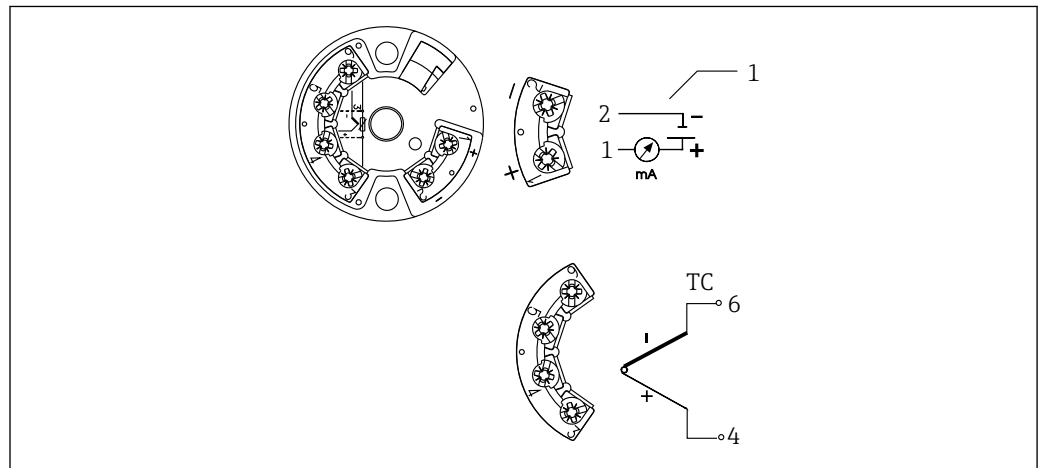

 11 Wiring diagram of the single sensor input head transmitters (TMT18x)

1 Power supply head transmitter and analog output 4 to 20 mA, or bus connection



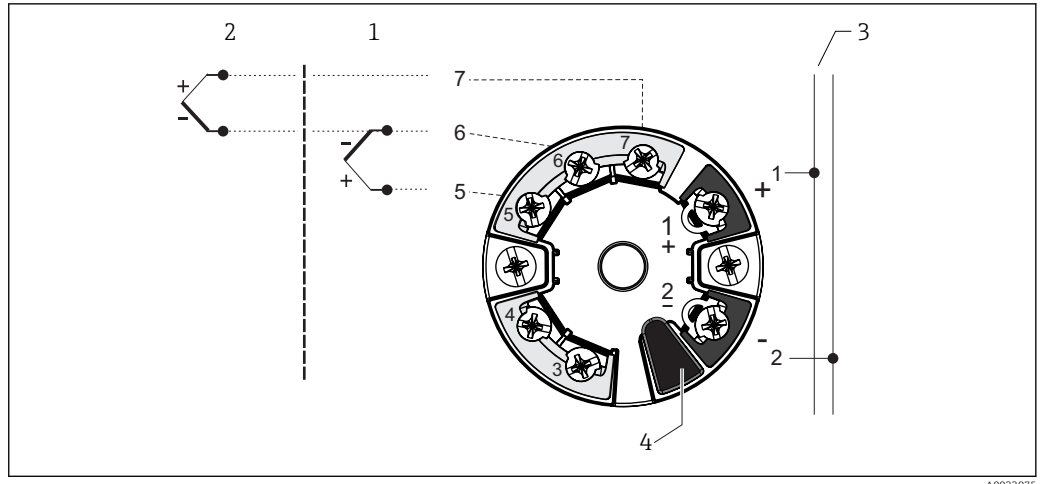

A0033075

12 Wiring diagram of the dual sensor input head transmitters (TMT8x)

- 1 Sensor input 1
- 2 Sensor input 2
- 3 Bus connection and supply voltage
- 4 Display connection

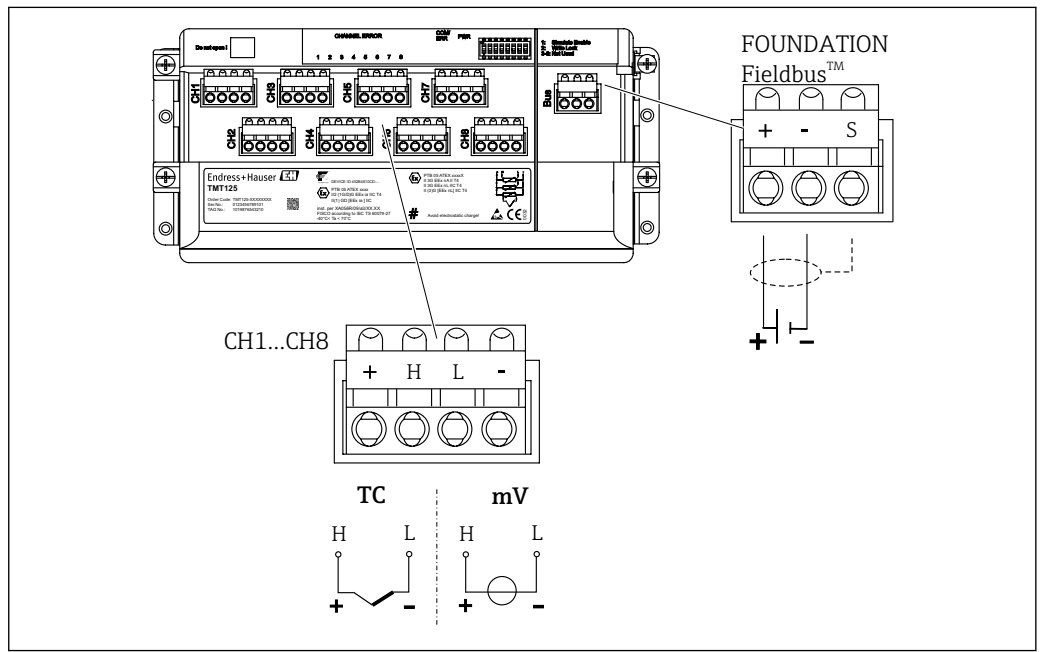

A0033071

13 Wiring diagram of multi-channel transmitter

## 11.4 Performance characteristics

### 11.4.1 Accuracy

Permissible deviation limits of thermoelectric voltages from standard characteristic for thermocouples as per IEC 60584 and ASTM E230/ANSI MC96.1:

Standard	Type	Standard tolerance	Special tolerance (on request)
ASTM E230/ MC. 96.1	Deviation, the larger respective value applies		
	K (NiCr-Ni)	$\pm 2.2 \text{ K } (\pm 3.96 \text{ }^\circ\text{F})$ or $\pm 0.02 \cdot  t $ (-200 to 0 °C (-328 to 32 °F) $\pm 2.2 \text{ K } (\pm 3.96 \text{ }^\circ\text{F})$ or $\pm 0.0075 \cdot  t $ (0 to 1260 °C (32 to 2 300 °F))	$\pm 1.1 \text{ K } (\pm 1.98 \text{ }^\circ\text{F})$ or $\pm 0.004 \cdot  t $ (0 to 1260 °C (32 to 2 300 °F))

Standard	Type	Standard tolerance	Special tolerance (on request)
	J (Fe-CuNi)	$\pm 2.2 \text{ K } (\pm 3.96 \text{ }^\circ\text{F})$ or $\pm 0.0075 \cdot  t $ (0 to 760 °C (32 to 1400 °F))	$\pm 1.1 \text{ K } (\pm 1.98 \text{ }^\circ\text{F})$ or $\pm 0.004 \cdot  t $ (0 to 760 °C (32 to 1400 °F))
	N (NiCrSi-NiSi)	$\pm 2.2 \text{ K } (\pm 3.96 \text{ }^\circ\text{F})$ or $\pm 0.02 \cdot  t $ (-200 to 0 °C (-328 to 32 °F)) $\pm 2.2 \text{ K } (\pm 3.96 \text{ }^\circ\text{F})$ or $\pm 0.0075 \cdot  t $ (0 to 1260 °C (32 to 2300 °F))	$\pm 1.1 \text{ K } (\pm 1.98 \text{ }^\circ\text{F})$ or $\pm 0.004 \cdot  t $ (0 to 1260 °C (32 to 2300 °F))
	E (NiCr-CuNi)	$\pm 1.7 \text{ K } (\pm 3.06 \text{ }^\circ\text{F})$ or $\pm 0.01 \cdot  t $ (-200 to 0 °C (-328 to 32 °F)) $\pm 1.7 \text{ K } (\pm 3.06 \text{ }^\circ\text{F})$ or $\pm 0.005 \cdot  t $ (0 to 870 °C (32 to 1598 °F))	$\pm 1 \text{ K } (\pm 1.8 \text{ }^\circ\text{F})$ or $\pm 0.004 \cdot  t $ (0 to 870 °C (32 to 1598 °F))

Standard	Type	Standard tolerance		Special tolerance (on request)	
		Class	Deviation	Class	Deviation
IEC60584	K (NiCr-Ni)	2	$\pm 2.5 \text{ }^\circ\text{C } (\pm 4.5 \text{ }^\circ\text{F})$ (-40 to 333 °C (-40 to 631.4 °F)) $\pm 0.0075 \cdot  t $ (333 to 1200 °C (631.4 to 2192 °F))	1	$\pm 1.5 \text{ }^\circ\text{C } (\pm 2.7 \text{ }^\circ\text{F})$ (-40 to 375 °C (-40 to 707 °F)) $\pm 0.004 \cdot  t $ (375 to 1000 °C (707 to 1832 °F))
	J (Fe-CuNi)	2	$\pm 2.5 \text{ }^\circ\text{C } (\pm 4.5 \text{ }^\circ\text{F})$ (-40 to 333 °C (-40 to 631.4 °F)) $\pm 0.0075 \cdot  t $ (333 to 750 °C (631.4 to 1382 °F))	1	$\pm 1.5 \text{ }^\circ\text{C } (\pm 2.7 \text{ }^\circ\text{F})$ (-40 to 375 °C (-40 to 707 °F)) $\pm 0.004 \cdot  t $ (375 to 750 °C (707 to 1382 °F))
	N (NiCrSi-NiSi)	2	$\pm 2.5 \text{ }^\circ\text{C } (\pm 4.5 \text{ }^\circ\text{F})$ (-40 to 333 °C (-40 to 631.4 °F)) $\pm 0.0075 \cdot  t $ (333 to 1200 °C (631.4 to 2192 °F))	1	$\pm 1.5 \text{ }^\circ\text{C } (\pm 2.7 \text{ }^\circ\text{F})$ (-40 to 375 °C (-40 to 707 °F)) $\pm 0.004 \cdot  t $ (375 to 1000 °C (707 to 1832 °F))
	E (NiCr-CuNi)	2	$\pm 2.5 \text{ }^\circ\text{C } (\pm 4.5 \text{ }^\circ\text{F})$ (-40 to 333 °C (-40 to 631.4 °F)) $\pm 0.0075 \cdot  t $ (333 to 900 °C (631.4 to 1652 °F))	1	$\pm 1.5 \text{ }^\circ\text{C } (\pm 2.7 \text{ }^\circ\text{F})$ (-40 to 375 °C (-40 to 707 °F)) $\pm 0.004 \cdot  t $ (375 to 800 °C (707 to 1472 °F))

### 11.4.2 Response time

 Response time for the sensor assembly without transmitter.

#### Tmax depending on thermocouple types [°C]

Diameter	N	K	J	E
1,5	920	920	440	510
1	700	700	260	300
0,5	700	700	260	300

#### Thermocouple (TC)

##### Test architecture

Multimeter Keithley 2000

Fluid bath for response time tests

##### Test description

Tests in water at 0.4 m/s (1.3 ft/s), according to IEC 60751 and ASTM E644; 10 K temperature step change.

At the beginning the thermometer to be tested is stabilized in its raised position, outside the fluid at ambient temperature, then it is immersed rapidly in the fluid bath. The measurement of the output values of the thermometer is started at latest at instant the thermometer enters the bath, and the recording is continued until the thermometer has reached the fluid temperature.

Tested thermowell diameter and length	Average response time at a temperature of 177 °C	
6 mm (0.24 in), 4520 mm (177.95 in)	t <sub>50</sub>	3 s
	t <sub>63</sub>	4.1 s
	t <sub>90</sub>	9 s

### 11.4.3 Additional tests (on request)

- Functional test measurement at a fixed temperature over the entire thermowell: the multipoint product under test is simultaneously checked by comparing its individual sensors with a reference multipoint device having an already known behavior and accuracy. This test has not to be seen as a calibration test.
- Thermal excitation: this test allows the evaluation of the response time of each measuring point when a local thermal excitation is applied. Additionally it shows the effects of the local excitation on the closest points due to the thermal equalization effect of the thermowell sheath.

### 11.4.4 Calibration

Calibration is a service that can be performed in house, either on single sensors before assembling or on the complete device before dispatching.

Calibration involves comparing the measured values of the sensing elements of the multipoint inserts (DUT device under test) with those of a more precise calibration standard using a defined and reproducible measurement method. The aim is to determine the deviation of the DUT measured values from the true value of the measured variable.

Two different methods are used for the inserts:

- Calibration at fixed-point temperatures, e.g. at the freezing point of water at 0 °C (32 °F).
- Calibration compared against a precise reference thermometer.

#### Evaluation of inserts

If a calibration with an acceptable uncertainty of measurement and transferable measurement results is not possible, Endress+Hauser offers an insert evaluation measurement service, if technically feasible.

## 11.5 Installation

### 11.5.1 Mounting location

The installation location must meet the requirements listed in this documentation, such as ambient temperature, protection classification, climatic class, etc... Care should be taken when checking the sizes of possible existing support frames or brackets welded on the reactor's wall (usually not included in the scope of delivery) or of any other existing frame in the installation area.

### 11.5.2 Orientation

It is recommended to install the multipoint thermometer in vertical configuration. When vertical installation is not possible, care has to be taken in order to ensure that the reinforcing sleeve is not under bending loads due to the any conduit cable tension.

When the flexible configuration is ordered, even not aligned routings are allowed thanks to the flexible part of the thermowell.

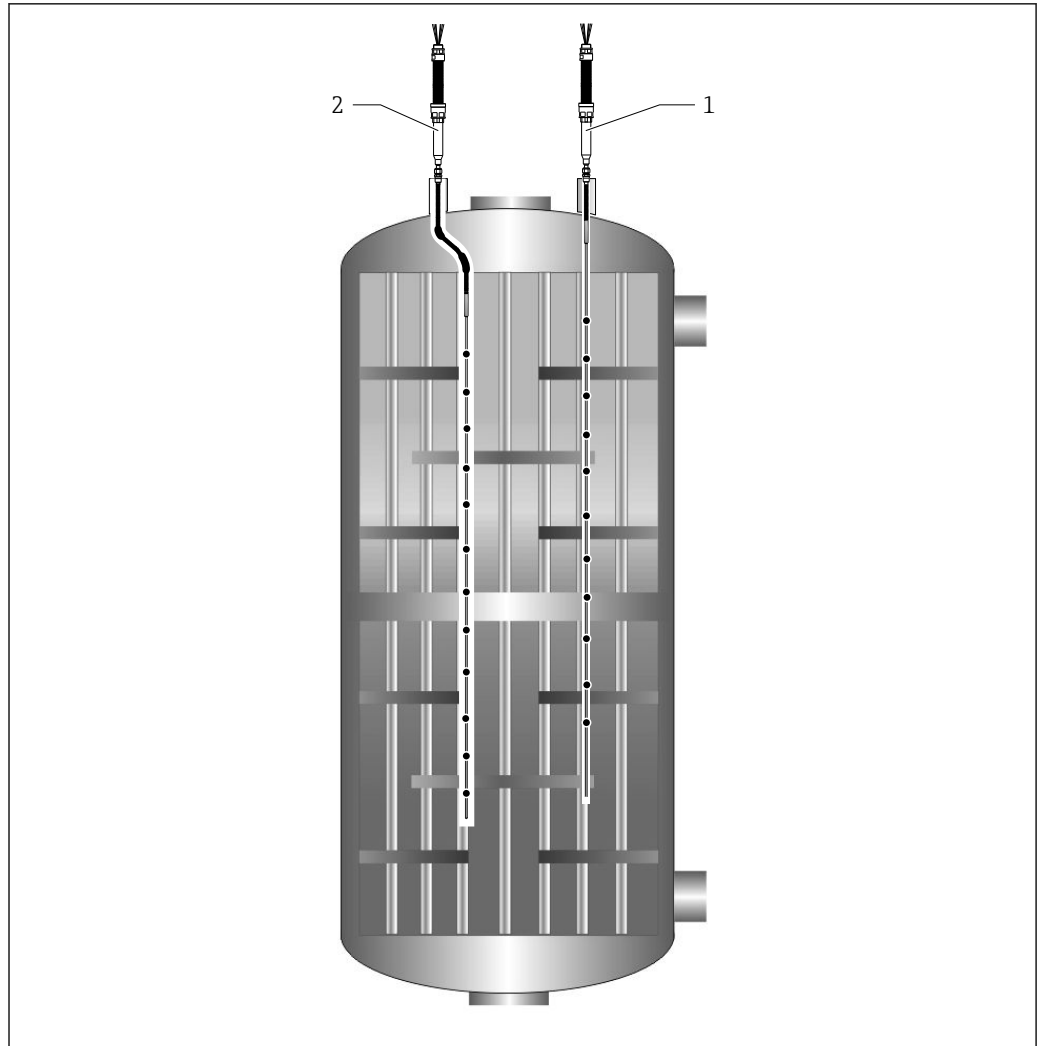

14 Main configuration possibilities

- 1 Vertical installation with rigid configuration
- 2 Installation with flexible configuration

### 11.5.3 Installation instructions

The multipoint thermometer is designed to be installed by means of a compression fitting, when necessary with a flange mounted on a vessel, reactor, tank or similar environment.

The thermometer has been developed to ensure utmost flexibility in terms of possible routing through any encumbrance and constraint that can be met in any plant. It guarantees a high sealing level, noiseless signals, and high mechanical protection of the extension cables.

All parts and components have to be handled with care. During the installation phase, lifting and introduction of the equipment through the preset nozzle, the following must be avoided:

- Misalignment with the nozzle axis.
- Any load on the welded or threaded parts due to the action of the weight of the device.
- Overtightening of the compression fittings.
- Any tensile and torsional load on the conduit cable.
- Any bending load on the conduit cable.
- Fixing the extension conduit on the plant's infrastructures without allowing axial displacements or movements.
- Deformation or crushing of the threaded components, bolts, nuts, cable glands and compression fittings.

- Bending radius of the flexible part of the thermowell smaller than 20 times the diameter of the flexible hose.
- Tension loads on the flexible part.
- Friction between the flexible part and the internals of the reactor.
- Fixing the flexible part on the reactor's infrastructures without allowing axial displacements or movements.

## 11.6 Environment

### 11.6.1 Ambient temperature range

Configuration without junction box: -50 to +95 °C (-58 to +203 °F)

Configuration with junction box, ordered as accessory:

Junction box	Non-hazardous area	Hazardous area
Without mounted transmitter	-50 to +85 °C (-58 to +185 °F)	-50 to +60 °C (-58 to +140 °F)
With mounted head transmitter	-40 to +85 °C (-40 to +185 °F)	Depends on the respective hazardous area approval. Details see Ex documentation.
With mounted multi-channel transmitter	-40 to +85 °C (-40 to +185 °F)	-40 to +70 °C (-40 to +158 °F)

### 11.6.2 Storage temperature

Configuration without junction box: -50 to +95 °C (-58 to +203 °F)

Configuration with junction box, ordered as accessory:

Junction box	
With head transmitter	-50 to +95 °C (-58 to +203 °F)
With multi-channel transmitter	-40 to +80 °C (-40 to +176 °F)
With DIN rail transmitter	-40 to +95 °C (-40 to +203 °F)

### 11.6.3 Humidity

Condensation according to IEC 60068-2-33:

- Head transmitter: Permitted
- DIN rail transmitter: Not permitted

Maximum relative humidity: 95% according to IEC 60068-2-30

### 11.6.4 Degree of protection

- Extension conduit: IP68
- Junction box: IP66/67

### 11.6.5 Electromagnetic compatibility (EMC)

Depending on the head transmitter used. For detailed information see the related Technical Information, listed at the end of this document.

## 11.7 Mechanical construction

### 11.7.1 Design, dimensions

The overall multipoint assembly is composed of standardized parts with different features allowing a wide range of product configurations. Different inserts, in terms of TC types, standards, materials, lengths and thermowells are available. They can be selected based upon specific process conditions, in order to have the highest application match and the most extended lifetime. Associated extension cables are provided with high resistance sheath materials and shielded for steady and noiseless signals signals, protected by a polymeric conduit to withstand different environmental conditions (salt, sand, humidity, etc.). The transition between the probe and the conduit is obtained by the usage of a main bushing, containing the electrical junctions between the TC sensors and the extension cables. It is completely sealed to ensure the declared degree of protection IP68.

It also works as the transition part between the reinforcing sleeve and the conduit cable for signal communication. The reinforcing sleeve is the dedicated probe's zone to adjust the immersion length through sliding compression fittings or flanges. For the flexible configuration the reinforcing sleeve has integrated the flexible thermowell that allows non-linear routings into the process. If there is a misalignment between the installation connection and the direction of the measurement given by the rigid part of the thermowell, the flex configuration is the proper solution.

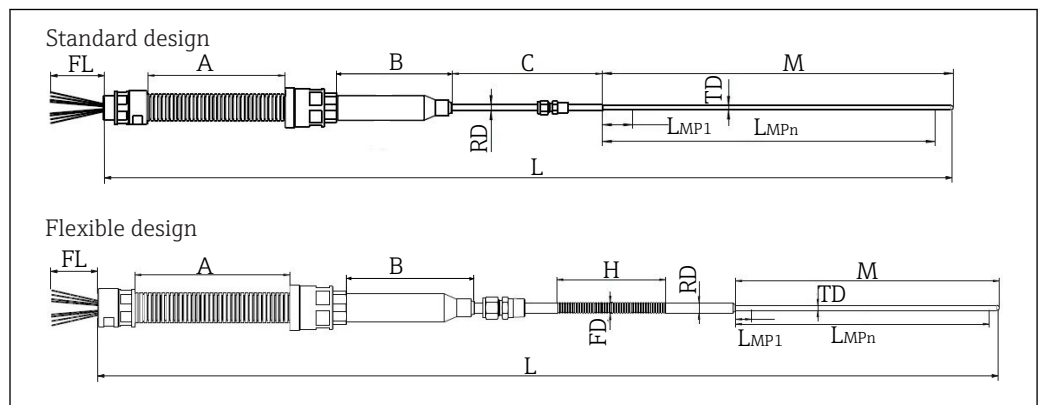

15 Design of the modular multipoint thermometer. All dimensions in mm (in)

- A Conduit cable length
- B Main bushing length (for configuration with max. 39 points = 220 mm (8,66 in), for configuration with more than 39 points = 240 mm (9,45 in))
- C Reinforcing sleeve length
- FD Flexible part diameter
- FL Flying leads length
- H Flexible part length
- $L_{MPx}$  Immersion length of sensing elements
- L Device length
- M Thermowell length
- RD Reinforcement diameter
- TD Thermowell diameter

Conduit cable length A and flying leads length FL in mm (in)
A: Maximum 5000 mm (197 in), minimum 1000 mm (39.4 in) FL: Maximum 500 mm (19.7 in) Specifically customized lengths are provided.

Reinforcing sleeve length C in mm (in)
180 (7.1) Specifically customized lengths are available on request.

Immersion lengths MPx of sensing elements:
Max. 13 m (512 in) Specifically customized lengths are available on request.

Flexible hose length H:
Max. 4 000 mm (157 in) Specifically customized lengths are available on request.

### Compression fitting pressure rating at ambient temperature

NPT/ISO Size	Bar	psi
1/4"	550	8000
1/2"	530	7700
3/4"	500	7300
1"	370	5300

### Thermowell diameter

 Different insert types are available. For any different requirement that is not described here, please contact the Endress+Hauser sales department.

Diameter in mm (in)	Sheath material	TC type	Standard	Hot junction type for TC
<ul style="list-style-type: none"> <li>▪ 3.2 mm (0.13 in)</li> <li>▪ 6 mm (0.24 in)</li> <li>▪ 6.35 mm (0.25 in)</li> <li>▪ 8 mm (0.31 in)</li> <li>▪ 9.5 mm (0.37 in)</li> </ul>	316, 316L Inconel600 316Ti 321 347	1x type K 1x type J 2x type K 2x type J	IEC 60584 ASTM E230	Grounded Ungrounded

Rigid	Main bushing	316 + 316L
	Reinforced sleeve + thermowell	316 + 316L, 347/321, Inconel600/316Ti
Flex	Main bushing	316 + 316L
	Reinforced sleeve	316 + 316L / 347 / 321, Inconel600 / 316Ti
	Thermowell	316 + 316L, 347/321, Inconel600/316Ti
	Flexible part	Inconel600 / 347 (specification on request) 321 / 316 + 316L (standard)

 For increased reliability, Endress+Hauser can offer double hot junction sensors for a sensor backup function, either by mean of double thermocouples or by coupling two independent sensors (having the same length). Improved monitoring can be achieved in combination with double channel transmitters TMT8x.

*Maximum number of inserts for every combination of thermowell and insert diameter*

		Thermowell OD in mm (in)				
		3.2 (0.13)	6 (0.24)	6.35 (0.25)	8 (0.31)	9.5 (0.37)
Insert diameter in mm (in)	0.5 (0.02)	8	28	22	46 <sup>1)</sup>	59 <sup>1)</sup>
	0.8 (0.03)	3	15	12	24	30

		Thermowell OD in mm (in)				
		3.2 (0.13)	6 (0.24)	6.35 (0.25)	8 (0.31)	9.5 (0.37)
	1 (0.04)	2	10	8	18	22
	1.5 (0.06)	1	6	4	8	12

1) for this configuration the main bushing have to be specially engineered

### 11.7.2 Weight

The weight can vary depending on the configuration: extension and thermowell length, type and dimensions of process connection as well as the number of inserts.

### 11.7.3 Materials of insert sheath, thermowell, main bushing and all wetted parts

The temperatures for continuous operation specified in the following table are only intended as reference values for use of the various materials in air and without any significant compressive load. The maximum operation temperatures are reduced considerably in some cases where abnormal conditions such as high mechanical load occur or in aggressive media.

Material name	Short form	Recommended max. temperature for continuous use in air	Properties
AISI 316/1.4401	X5CrNiMo 17-12-2	650 °C (1202 °F)	<ul style="list-style-type: none"> <li>▪ Austenitic, stainless steel</li> <li>▪ High corrosion resistance in general</li> <li>▪ Particularly high corrosion resistance in chlorine-based and acidic, non-oxidizing atmospheres through the addition of molybdenum (e.g. phosphoric and sulfuric acids, acetic and tartaric acids with a low concentration)</li> </ul>
AISI 316L/ 1.4404 1.4435	X2CrNiMo17-12-2 X2CrNiMo18-14-3	650 °C (1202 °F)	<ul style="list-style-type: none"> <li>▪ Austenitic, stainless steel</li> <li>▪ High corrosion resistance in general</li> <li>▪ Particularly high corrosion resistance in chlorine-based and acidic, non-oxidizing atmospheres through the addition of molybdenum (e.g. phosphoric and sulfuric acids, acetic and tartaric acids with a low concentration)</li> <li>▪ Increased resistance to intergranular corrosion and pitting</li> <li>▪ Compared to 1.4404, 1.4435 has even higher corrosion resistance and a lower delta ferrite content</li> </ul>
Alloy600/ 2.4816	NiCr15Fe	1100 °C (2012 °F)	<ul style="list-style-type: none"> <li>▪ A nickel/chromium alloy with very good resistance to aggressive, oxidizing and reducing atmospheres, even at high temperatures</li> <li>▪ Resistance to corrosion caused by chlorine gases and chlorinated media as well as many oxidizing mineral and organic acids, sea water etc.</li> <li>▪ Corrosion from ultrapure water</li> <li>▪ Not to be used in sulfur-containing atmospheres</li> </ul>
AISI 304/1.4301	X5CrNi18-10	850 °C (1562 °F)	<ul style="list-style-type: none"> <li>▪ Austenitic, stainless steel</li> <li>▪ Well usable in water and lowly pollute waste water</li> <li>▪ Only at relatively low temperatures resistant to organic acids, saline solutions, sulphates, alkaline solutions, etc.</li> </ul>



Material name	Short form	Recommended max. temperature for continuous use in air	Properties
AISI 304L/ 1.4307	X2CrNi18-9	850 °C (1562 °F)	<ul style="list-style-type: none"> <li>▪ Good welding properties</li> <li>▪ Impervious to intergranular corrosion</li> <li>▪ High ductility, excellent drawing, forming, and spinning properties</li> </ul>
AISI 316Ti/ 1.4571	X6CrNiMoTi17-12-2	700 °C (1292 °F)	<ul style="list-style-type: none"> <li>▪ Addition of titanium means increased resistance to intergranular corrosion even after welding</li> <li>▪ Broad range of uses in the chemical, petrochemical and oil industries as well as in coal chemistry</li> <li>▪ Can only be polished to a limited extent, titanium streaks can form</li> </ul>
AISI 321/1.4541	X6CrNiTi18-10	815 °C (1499 °F)	<ul style="list-style-type: none"> <li>▪ Austenitic stainless steel</li> <li>▪ High resistance to intergranular corrosion even after welding</li> <li>▪ Good welding characteristics, suitable to all standard welding methods</li> <li>▪ It is used in many sectors of the chemical industry, petrochemical, and pressurized vessels</li> </ul>
AISI 347/1.4550	X6CrNiNb10-10	800 °C (1472 °F)	<ul style="list-style-type: none"> <li>▪ Austenitic stainless steel</li> <li>▪ Good resistance to a wide variety of environments in the chemical, textile, oil-refining, dairy and food industries</li> <li>▪ Added niobium makes this steel impervious to intergranular corrosion</li> <li>▪ Good weldability</li> <li>▪ Main applications are furnace fire walls, pressure vessels, welded structures, turbine blades</li> </ul>

### 11.7.4 Process connection

#### Flanges

Examples of most common flanges according to the following standards: ASME, EN

Standard <sup>1)</sup>	Size	Rating	Material <sup>2)</sup>
ASME	½", 1", 1½", 2", 3", 4"	150#, 300#	AISI 316, 316L, 316Ti, 321, 347
EN	DN15, DN25, DN32, DN40, DN50	PN10,PN16, PN40	

1) Other flange standards are available on request. Please refer to our technicians for support.

2) Plated flanges with special alloys (i.e. Alloy 600) are available

#### Compression fittings

The compression fittings are used directly as the process connection or welded or threaded into the flange to ensure proper process tightness and performances. Dimensions are coherent with the reinforcing sleeve dimensions.

## 11.8 Operability

For details of operability, see the Technical Information of the Endress+Hauser temperature transmitters or the manuals of the related operating software. →  43

## 11.9 Certificates and approvals

### 11.9.1 CE Mark

The complete assembly is provided with individual components CE marked, to ensure safe use in hazardous areas and pressurized environments.

### 11.9.2 Hazardous area approvals

The Ex approval applies to individual components like junction box, cable glands, terminals. For further details on the available Ex versions (ATEX, UL, FM, CSA, IEC-EX, NEPSI, EAC-EX), please contact your nearest Endress+Hauser sales organization. All relevant data for hazardous areas can be found in separate Ex documentation.

ATEX Ex ia inserts are available only for diameters  $\geq 1.5$  mm (0.6 in). For further details contact an Endress+Hauser technician.

### 11.9.3 Certification HART

The HART<sup>®</sup> temperature transmitter is registered by the FieldComm Group. The device meets the requirements of the HART<sup>®</sup> Communication Protocol Specifications.

### 11.9.4 Certification FOUNDATION Fieldbus

The FOUNDATION Fieldbus<sup>™</sup> temperature transmitter has successfully passed all test procedures and is certified and registered by the Fieldbus Foundation. The device thus meets all the requirements of the following specification:

- Certified according to FOUNDATION Fieldbus<sup>™</sup> specification
- FOUNDATION Fieldbus<sup>™</sup> H1
- Interoperability Test Kit (ITK), up to date revision status (device certification no. available on request): the device can also be operated with certified devices of other manufacturers
- Physical layer conformance test of the FOUNDATION Fieldbus<sup>™</sup>

### 11.9.5 Certification PROFIBUS<sup>®</sup> PA

The PROFIBUS<sup>®</sup> PA temperature transmitter is certified and registered by the PNO (PROFIBUS<sup>®</sup> Nutzerorganisation e. V.), PROFIBUS user organization. The device meets all the requirements of the following specifications:

- Certified according to FOUNDATION Fieldbus<sup>™</sup> specification
- Certified in accordance with PROFIBUS<sup>®</sup> PA Profile (the up to date profile version is available on request)
- The device can also be operated with certified devices of other manufacturers (interoperability)

### 11.9.6 Other standards and guidelines

- EN 60079: ATEX certification for hazardous areas
- IEC 60529: Degree of protection of housing (IP code)
- IEC 60584 and ASTM E230/ANSI MC96.1: Thermocouples

### 11.9.7 Material certification

The material certificate 3.1 (according to EN 10204) can be requested separately. The certificate includes a declaration related to the materials used to produce the thermometer. It guarantees the traceability of the materials through the identification number of the multipoint thermometer.

### 11.9.8 Test report and calibration

The "Factory calibration" is carried out according to an internal procedure in a laboratory of Endress+Hauser accredited by the European Accreditation Organization (EA) to ISO/IEC 17025. A calibration which is performed according to EA guidelines (SIT/Accredia) or (DKD/DAkKS) may be requested separately. The calibration is performed on the inserts of the multipoint.

### 11.10 Documentation

- Operating manuals iTEMP temperature transmitters:
  - TMT181, PC programmable, single-channel, RTD, TC,  $\Omega$ , mV (KA141R/09/a3)
  - HART<sup>®</sup> TMT182, single-channel, RTD, TC,  $\Omega$ , mV (KA142R/09/c4)
  - HART<sup>®</sup> TMT82, two-channel, RTD, TC,  $\Omega$ , mV (BA01028T/09/en)
  - PROFIBUS<sup>®</sup> PA TMT84, two-channel, RTD, TC,  $\Omega$ , mV (BA00257R/09/en)
  - FOUNDATION Fieldbus<sup>™</sup> TMT85, two-channel, RTD, TC,  $\Omega$ , mV (BA00251R/09/en)
  - FOUNDATION Fieldbus<sup>™</sup> TMT125, 8 channel, RTD, TC,  $\Omega$ , mV (BA00240R/09/en)
- Technical Information of inserts:
  - Thermocouple insert Omnigrad T TSC310 (TI00255t/09/en)
- Technical Information application example:
  - RN221N active barrier, for supplying loop-powered 2-wire transmitters (TI073R/09/en)
  - HAW562 surge arresters, (TI01012K/09/en)

[www.addresses.endress.com](http://www.addresses.endress.com)

---