

Operating Instructions

iTHERM TMS11

MultiSens Linear

Modular TC and RTD multipoint with primary thermowell

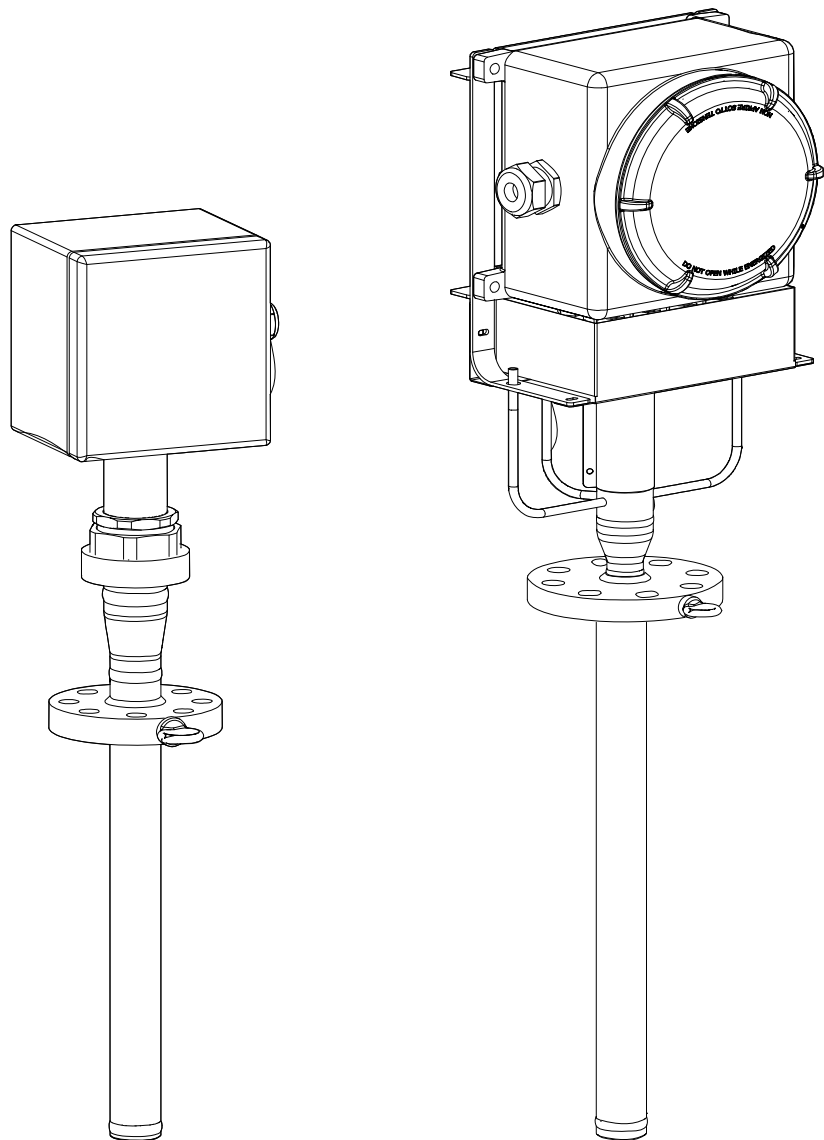

Table of contents

1	About this document	4	10	Accessories	32
1.1	Document function	4	10.1	Device-specific accessories	32
1.2	Symbols	4	10.2	Communication-specific accessories	32
			10.3	Service-specific accessories	33
2	Basic safety instructions	6	11	Technical data	34
2.1	Requirements for the personnel	6	11.1	Input	34
2.2	Designated use	6	11.2	Output	34
2.3	Workplace safety	7	11.3	Performance characteristics	35
2.4	Operational safety	7	11.4	Environment	37
2.5	Product safety	7	11.5	Mechanical construction	38
3	Product description	8	11.6	Certificates and approvals	47
3.1	Equipment architecture	8	11.7	Documentation	48
4	Incoming acceptance and product identification	12			
4.1	Incoming acceptance	12			
4.2	Product identification	12			
4.3	Storage and transport	13			
5	Mounting	14			
5.1	Mounting requirements	14			
5.2	Mounting the assembly	14			
5.3	Post-mounting check	16			
6	Wiring	18			
6.1	Quick wiring guide	18			
6.2	Connecting the sensor cables	19			
6.3	Connecting the power supply and signal cables	21			
6.4	Shielding and grounding	21			
6.5	Degree of protection	21			
6.6	Post-connection check	22			
7	Commissioning	23			
7.1	Preliminaries	23			
7.2	Function check	23			
7.3	Switching on the device	25			
8	Diagnostics and troubleshooting ...	25			
8.1	General troubleshooting	25			
9	Maintenance and Repair	26			
9.1	General notes	26			
9.2	Spare parts	26			
9.3	Endress+Hauser services	30			
9.4	Return	31			
9.5	Disposal	31			





1 About this document

1.1 Document function





These Operating Instructions contain all the information that is required in various phases of the life cycle of the device: from product identification, incoming acceptance and storage, to mounting, connection, operation and commissioning through to troubleshooting, maintenance and disposal.

1.2 Symbols



1.2.1 Safety symbols









Symbol	Meaning
	DANGER! This symbol alerts you to a dangerous situation. Failure to avoid this situation will result in serious or fatal injury.
	WARNING! This symbol alerts you to a dangerous situation. Failure to avoid this situation can result in serious or fatal injury.
	CAUTION! This symbol alerts you to a dangerous situation. Failure to avoid this situation can result in minor or medium injury.
	NOTE! This symbol contains information on procedures and other facts which do not result in personal injury.

1.2.2 Electrical symbols

Symbol	Meaning
	Direct current
	Alternating current
	Direct current and alternating current
	Ground connection A grounded terminal which, as far as the operator is concerned, is grounded via a grounding system.
	Protective Earth (PE) A terminal which must be connected to ground prior to establishing any other connections. The ground terminals are situated inside and outside the device: <ul style="list-style-type: none"> ▪ Inner ground terminal: Connects the protective earth to the mains supply. ▪ Outer ground terminal: Connects the device to the plant grounding system.

1.2.3 Symbols for certain types of information

Symbol	Meaning
	Permitted Procedures, processes or actions that are permitted.
	Preferred Procedures, processes or actions that are preferred.

Symbol	Meaning
	Forbidden Procedures, processes or actions that are forbidden.
	Tip Indicates additional information.
	Reference to documentation
	Reference to page
	Reference to graphic
	Series of steps
	Result of a step
	Help in the event of a problem
	Visual inspection

1.2.4 Documentation

Document	Purpose and content of the document
iTHERM TMS11 MultiSens Linear (TIxxxxT/09/xx)	Planning aid for your device The document contains all the technical data on the device and provides an overview of the accessories and other products that can be ordered for the device.

 The document types listed are available:
In the Download Area of the Endress+Hauser Internet site: www.endress.com → Downloads

1.2.5 Registered trademarks

- FOUNDATION™ Fieldbus
Registered trademark of the Fieldbus Foundation, Austin, Texas, USA
- HART®
Registered trademark of the HART® FieldComm Group
- PROFIBUS®
Registered trademark of the PROFIBUS Nutzerorganisation e.V. (Profibus User Organization), Karlsruhe - Germany

2 Basic safety instructions

Instructions and procedures in the operating instructions may require special precautions to ensure the safety of the personnel performing the operations. Information that potentially raises safety issues is indicated by safety pictograms and symbols. Please refer to the safety messages before performing an operation preceded by pictograms and symbols. Although the information provided herein is believed to be accurate, be advised that the information contained herein is NOT a guarantee of satisfactory results. Specifically, this information is neither a warranty nor guarantee, expressed or implied, regarding performance. Please note that the manufacturer reserves the right to change and / or improve the product design and specifications without notice.

2.1 Requirements for the personnel

The personnel for installation, commissioning, diagnostics and maintenance must fulfill the following requirements:

- ▶ Trained, qualified specialists must have a relevant qualification for this specific function and task
- ▶ Are authorized by the plant owner/operator
- ▶ Are familiar with federal/national regulations
- ▶ Before beginning work, the specialist staff must have read and understood the instructions in the Operating Instructions and supplementary documentation as well as in the certificates (depending on the application)
- ▶ Following instructions and basic conditions

The operating personnel must fulfill the following requirements:

- ▶ Being instructed and authorized according to the requirements of the task by the facility's owner-operator
- ▶ Following the instructions in these Operating Instructions

2.2 Designated use

The product is intended to measure the temperature profile inside a reactor, vessel or pipe through RTD or thermocouple technologies.

The manufacturer is not liable for damage caused by improper or non-designated use.

The product has been designed according to the following conditions:

Condition	Description
Internal pressure	The design of joints, threaded connections and sealing elements has been executed as a function of the maximum allowable pressure inside the reactor.
Operating temperature	The materials used were chosen according to the operating and design minimum and maximum temperatures. Thermal displacement has been taken into account to avoid intrinsic stresses and to ensure proper integration between the instrument and the plant. Specific care has to be taken when the instrument is fixed to the plant internals.
Process fluids	Dimensions and choice of materials minimize: <ul style="list-style-type: none"> ▪ distributed and localized corrosion, ▪ erosion and abrasion, ▪ corrosion phenomena due to uncontrolled and unpredictable chemical reactions. Specific process fluids analysis is necessary to properly ensure the maximum operating life of the device, through proper material selection.
Fatigue	Cyclic loads during operations are not foreseen.

Condition	Description
Vibrations	The primary thermowell and sensing elements can be subjected to vibrations, due to high immersion lengths from the constraint located in the process connections. This vibrations can be minimized by properly selecting the product configuration of the temperature assembly. The extension neck has been designed for withstanding vibratory loads to preserve the junction box from cyclic loading, and to avoid the unscrewing of the threaded components.
Mechanical stress	The maximum stress on the measuring device multiplied by a safety factor is guaranteed to stay below the yielding stress of the material, for every working condition of the plant.
External environment	The junction box (with and without head transmitters), wires, cable glands and other fittings have been selected to work within the allowed ranges in terms of external temperature.

2.3 Workplace safety

The external installation area must be free of interferences to avoid any injury during installation, and to avoid any damage to the measuring device.

2.4 Operational safety

- ▶ Operate the device in proper technical condition and fail-safe condition only.
- ▶ The operator is responsible for interference-free operation of the device.

Hazardous area

To eliminate a danger for persons or for the facility when the device is used in the hazardous area (e.g. explosion protection or safety equipment):

- ▶ Based on the technical data on the nameplate, check whether the ordered device is permitted for the intended use in the hazardous area. The nameplate can be found on the side of the junction box.
- ▶ Observe the specifications in the separate supplementary documentation that is an integral part of these Instructions.

Electromagnetic compatibility

The measuring system complies with the general safety requirements in accordance with EN 61010-1, the EMC requirements of IEC/EN 61326 and NAMUR Recommendation NE 21 and NE 89.

NOTICE

- ▶ The unit must only be powered by a power supply that operates using an energy-limited electric circuit that is compliant with IEC 61010-1, "SELV or Class 2 circuit".

2.5 Product safety

The unit is constructed using the most up-to-date production equipment and complies with the safety requirements of the local guidelines. The temperature measuring system is fully factory tested according to the specifications indicated on the order and/or any additional test which is considered as safety-relevant. However, if it is installed incorrectly or is misused, certain application dangers can occur. Installation, wiring and maintenance of the unit must only be done by trained, skilled personnel who are authorized to do so by the plant operator. This skilled staff must have read and understood these instructions and must follow them. The plant operator must make sure that the measurement system has been installed by tightening the threaded components (e.g bolts and nuts) with the predefined torques and tools, and correctly wired according to the wiring diagrams.

3 Product description

3.1 Equipment architecture

The multipoint thermometer belongs to a range of modular product configuration for multipoint temperature detection with a design where subassemblies and components can be managed individually for easy maintenance and spare part ordering.

It consists of the following main sub-assemblies:

- **Insert:** Composed by individual metal sheathed sensing elements (thermocouples or thermos-resistance) protected by the primary thermowell welded to the process connection. In addition, individual guiding tubes or protecting thermowells allow inserts replacement during operating conditions. When applicable, each insert can be handled as an individual spare part and ordered via specific standard product order codes (e.g. TSC310, TST310) or special codes. For the specific order code please contact your Endress+Hauser specialist.
- **Process Connection:** Represented by an ASME or EN flange. It can be provided with pressure port and it might be provided with eyebolts for lifting the device.
- **Head:** It is composed of a junction box provided with its components such as cable glands, draining valves, earth screws, terminals, head transmitters, etc.
- **Head Support Frame:** It is designed to support the junction box. Two different types are available:
 - Direct mounted support frame
 - Three pieces union joint
- **Additional Accessories:** They can be ordered for any configuration, and they are recommended in case of replaceable sensors configuration (such as pressure transducers, manifolds, valves and fitting).
- **Primary Thermowell:** It is directly welded to the process connection, designed to guarantee high degree of mechanical protection and corrosion resistance.

In general, the system measures a linear temperature profile inside the process environment. It is also possible to obtain a three-dimensional temperature profile by installing more than one Multisens Linear (either horizontally, vertically or obliquely).

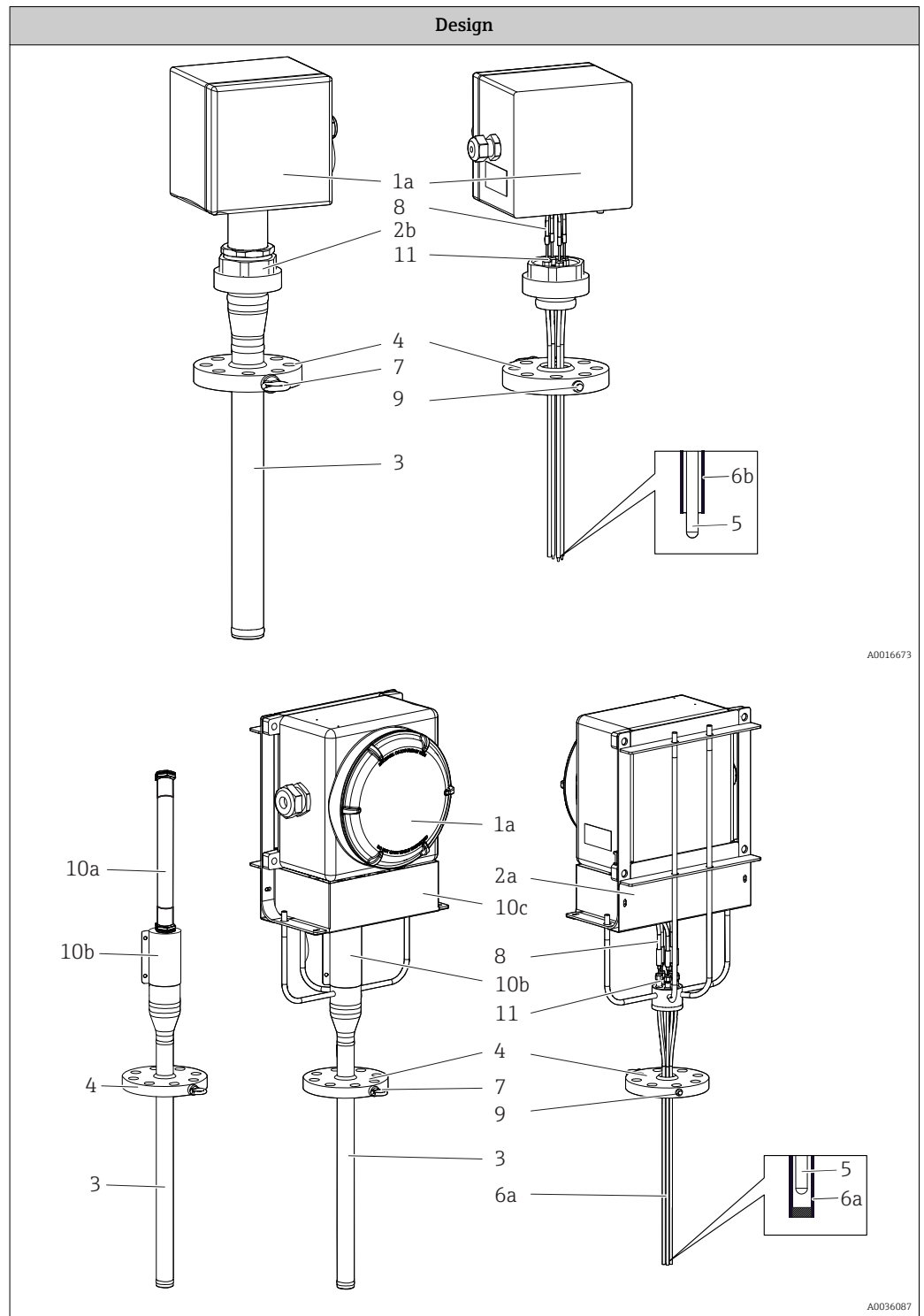

Description, available options and materials	
1: Head 1a: Directly mounted 1b: Remote	Hinged or screwed cover junction box for electrical connections. It includes components such as electrical terminals, transmitters and cable glandes. <ul style="list-style-type: none"> ▪ 316/316L ▪ Aluminium alloys ▪ Other materials on request
2: Support System 2a: With rods and protection cover	Support frame for explosion proof requirements. 316/316L
2b: With three pieces union joint	Support frame for intrinsically safe requirements. 316/316L
3: Primary thermowell	The primary thermowell is made by a tube with calculated and selected thickness according to reference international standards. It is designed to protect the sensors against harsh process conditions such as dynamic and static loads and corrosion. It is composed of two main zones, one inside the process and the other one outside of the process (thermowell head). The main thermowell goes across the process connection and on the upper part there are compression fitting to allow insert replacement (when possible) <ul style="list-style-type: none"> ▪ 316/316L ▪ 321 ▪ 304/304L ▪ 310L
4: Process connection, flanged according to ASME, or EN standards	Represented by a flange according to international standards, or engineered to satisfy specific process requirements → 38. <ul style="list-style-type: none"> ▪ 316 + 316L ▪ 304/304L ▪ 310L ▪ 321 ▪ Other materials on request
5: Insert	Mineral insulated grounded and ungrounded thermocouples or RTD (Pt100 wire wound). For details, refer to the Ordering information table
6 Tip design of: 6a: protecting thermowells	The sensors inside the primary thermowell can be kept in the right measuring location by means of closed-end protecting thermowells which end with: <ul style="list-style-type: none"> ▪ welded thermal block discs to ensure the optimal heat transfer thorough the primary thermowell wall and the temperature sensors. Sensors are replaceable. ▪ individual thermal blocks pressed against the internal wall to ensure the optimal heat transfer between the primary thermowell and the replaceable temperature sensor. ▪ straight tip. For details, refer to the Ordering information table
6b: guiding tubes	The sensors inside the primary thermowell can be kept in the right measuring location by means of open-end guiding tubes which end with: <ul style="list-style-type: none"> ▪ bimetallic stripes to push the sensor in contact with the internal wall of the main thermowell and allow faster response time. Sensors not replaceable. ▪ bent tip.
7: Eyebolt	Lifting device for easy handling during installation phase. SS 316
8: Extension cables	Cables for electrical connections between the inserts and junction box. <ul style="list-style-type: none"> ▪ Shielded PVC ▪ Shielded Hyflon MFA ▪ Unshielded PVC flying leads

Description, available options and materials	
9: Optional connection (Pressure Port threaded hole)	Auxiliary connections and fittings for pressure detection.
10: Protections 10a: Cable conduit system (in case of remote head) 10b: Cable conduit cover 10c: Extension cable cover	Cable conduit system: made by flexible polyamide to connect the top of the primary thermowell and the remote junction box. Cable conduit cover: composed of two half shields installed between the top of the primary thermowell and the junction box. Extension cable cover: made by a shaped stainless steel plate fixed to the junction box frame in order to protect the cable connections.
11: Compression fitting	High performing fittings for the tightness between the thermowell-head and the external environment, suitable for a wide range of process fluids and severe combination between temperature and pressure.

4 Incoming acceptance and product identification

4.1 Incoming acceptance

Before proceeding with the installation the following incoming acceptance procedures are suggested:

- Once the device is received it is always suggested to verify the integrity of the packaging and possible damages. Non-compliances should be immediately reported to the manufacturer. Damaged material shall not be installed: in these conditions, in fact, the manufacturer cannot guarantee the original safety requirements and cannot be considered responsible for any consequential effect.
- Compare the scope of delivery with the order content.
- Carefully remove all packaging/protection related to the freight.

4.2 Product identification

The following options are available for identification of the device:

- Nameplate specifications
- Enter the serial number from the nameplate in the *W@M Device Viewer* (www.endress.com/deviceviewer): All data relating to the device and an overview of the Technical Documentation supplied with the device are displayed.

The following nameplate layout serves to identify the specific product information from the serial number, design conditions, sizes, configuration to approvals:

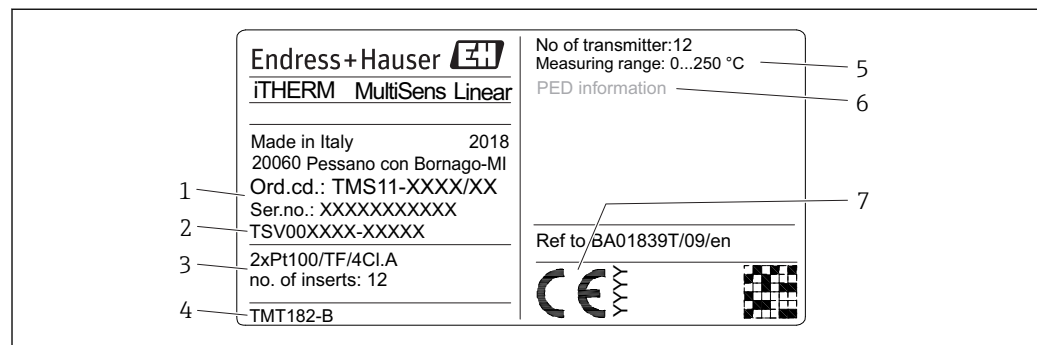

A0016719

1 Nameplate of the multipoint thermometer (example as landscape format)

Field number	Description	Examples
1	Order code and serial number	TMS11-xxxxx
2	TSV drawing number	TSV012345-XXXXX
3	Sensor and product configuration	e.g. number of measuring points
4	Assembled transmitter	-
5	Sensor measuring temperature range	-
6	PED information (if applicable)	e.g. volume, pressure, temperature

Field number	Description	Examples
7	CE marking (if applicable)	-
-	Approval number, hazardous area classification and Ex logo (if applicable) Safety instructions number (if applicable) Ambient temperature (if hazardous area classification is applicable)	e.g. -50 to 60 °C (-58 to 140 °F) for hazardous area application

 Compare and check the data on the nameplate of the device against the requirements of the measurement environment.

4.3 Storage and transport

Carefully remove each package and protection relative to the transportation packaging.

NOTICE

Transportation of the device to the installation area.

- ▶ Handle the device by always using the provided eyebolt as the main lifting part.
- ▶ Handle with care. During mounting phases avoid any load to welded or threaded parts, under the action of the weight of the device.
- ▶ When the device has to pass from the horizontal to the vertical position or vice versa, particular attention must be taken.
- ▶ It is strictly requested to avoid bumping against obstacles nearby the place where the device has to be installed.
- ▶ Avoid any friction between the device and the other surrounding bodies.

 Pack the device in such a way as to protect it reliably against impact for storage and transportation. The original packaging provides optimum protection.

For permitted storage temperature →  37

5 Mounting

5.1 Mounting requirements

⚠ WARNING

Failure to follow these installation guidelines could result in death or serious injury

- ▶ Make sure only qualified personnel perform the installation.

⚠ WARNING

Explosions could result in death or serious injury

- ▶ Before connecting any additional electric and electronic device in an explosive atmosphere, make sure the instruments in the loop are installed in accordance with intrinsically safe or non incendive field wiring practices.
- ▶ Verify that the operating atmosphere of the transmitters is consistent with the appropriate hazardous locations certifications.
- ▶ All covers and threaded components must be fully engaged to meet explosion-proof requirements.

⚠ WARNING

Process leaks could result in death or serious injury

- ▶ Do not release screwed parts while in operation. Install and tighten the fittings before applying pressure.

NOTICE

Additional loads and vibrations from other plant components can affect the operation of the sensor elements.

- ▶ Is it not allowed to apply additional loads or external moments to the system coming from the connection with another system not foreseen from installation plan.
- ▶ The system is not suitable for being installed in locations where vibrations are present. The deriving loads can undermine the sealing of the junctions and damage the operation of the sensing elements.
- ▶ It will be care of the final user to verify the installation of suitable devices in order to avoid the overcoming of the admitted limits.
- ▶ For the environment conditions please refer to the technical data →  37
- ▶ While installing the measurement system, avoid any friction, specifically avoid sparks generation.
- ▶ When the installation is performed by using existing vessel internal infrastructures, ensure that any applied external loads (i.e. to the tip of the primary thermowell) don't generate deformations and strains on the device and especially on welds.

5.2 Mounting the assembly

5.2.1 Mounting sequence

When installing the device, it is recommended to perform an internal inspection of the vessel. Check if there is any obstacle, with the aim of making an easy insertion. While installing the measurement system, avoid any friction during installation, specifically avoid sparks generation.

1.

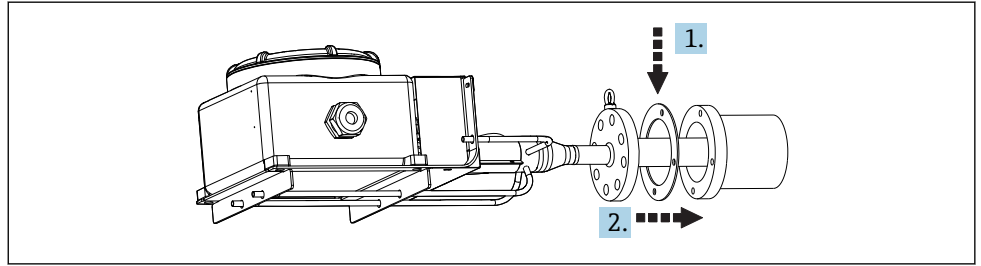

A0036096

Place the gasket between the flanged nozzle and the flange of the device (after checking the cleanliness of gasket seats on the flanges).

2.

Bring the device to the nozzle, inserting the main thermowell through the nozzle avoiding deformation.

3.

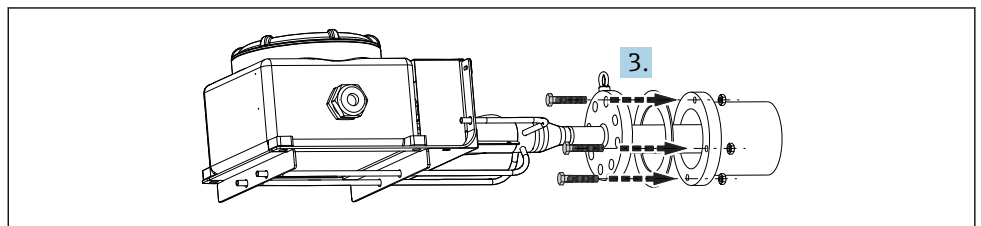

A0036097

Start the bolts insertion through the flanges' holes and tighten them with the nuts by using a suitable wrench tool - but do not tighten them completely.

4.

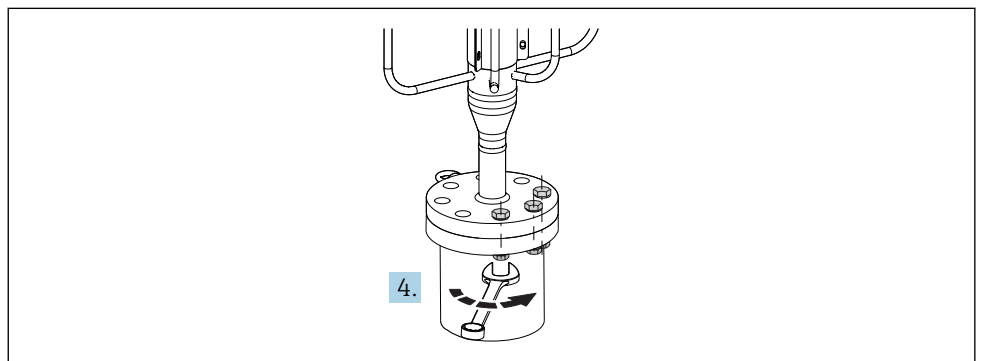

A0036533

Complete the bolts insertion through the flanges' holes and tight them with the crossed method by means of an appropriate equipment (i.e. controlled tensioning according to the applicable standards).

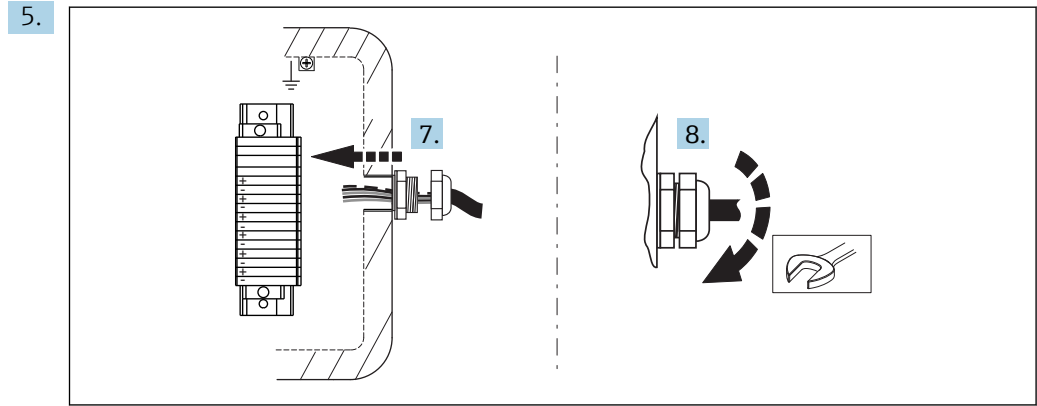

2 View from user side

To wire the system, after having opened the cover of the junction box introduce the extension or compensating cables through the respective cable glands in the junction box.

6. Tighten the cable glands on the junction box.
7. Connect the cables to the terminals or temperature transmitters of the junction box following the wiring instruction provided, ensuring the right matching between the cable tag numbers and the terminals tag numbers.
8. Close the cover ensuring the right gasket position to avoid any impact on the IP degree of protection and set the draining valve in the right position (for humidity condensation control).

NOTICE

After the mounting, perform few simple checks on the installed thermometric system.

- ▶ Check the tightness of the threaded connections. If any part is loosened, tight it applying the proper torque.
- ▶ Check for correct wiring, test the electrical continuity of the thermocouples (warming up the thermocouple hot junction, when feasible) and then verify the absence of short circuits.

5.3 Post-mounting check

Before commissioning the measuring system make sure that all final checks have been carried out:

Device conditions and specifications	
Is the device undamaged (visual inspection)?	<input type="checkbox"/>
Do the ambient conditions match the device specification? For example: <ul style="list-style-type: none"> ■ Ambient temperature ■ Proper conditions 	<input type="checkbox"/>
Are the threaded components undeformed?	<input type="checkbox"/>
Are the gaskets not permanently deformed?	<input type="checkbox"/>
Installation	
Is the equipment aligned with the nozzle axis?	<input type="checkbox"/>
Are the gasket seats of flanges clean?	<input type="checkbox"/>
Is the coupling between the flange and its counter flange reached?	<input type="checkbox"/>
Is the primary thermowell undeformed?	<input type="checkbox"/>

Are the bolts completely inserted in the flange? Make sure the flange is completely attached to the nozzle.	<input type="checkbox"/>
Is the primary thermowell properly fixed to the internal infrastructures (when applicable)?	<input type="checkbox"/>
Are the cable glands tightened on the extension cables?	<input type="checkbox"/>
Are the extension cables connected to the junction box terminals?	<input type="checkbox"/>
Are the extension cable protections (when ordered) properly assembled and closed?	<input type="checkbox"/>

6 Wiring

CAUTION

Failure to observe this may result in destruction of parts of the electronics.

- ▶ Switch off power supply before installing or connecting the device.
- ▶ When installing devices in a hazardous area please take special note of the instructions and connection schematics in the respective Ex documentation added to these Operating Instructions. The local Endress+Hauser representative is available for assistance if required.

 When wiring to a transmitter also observe the wiring instructions in the enclosed Brief Operating manuals of the relevant transmitter.

For wiring the device proceed as follows:

1. Open the housing cover on the junction box.
2. Open the cable glands on the sides of the junction box.
3. Feed the cables through the opening in the cable glands.
4. Connect the cables as shown on
5. On completion of the wiring, screw the terminals tight. Tighten the cable glands again. Close the housing cover.
6. In order to avoid connection errors always take note of the hints given in the post connection check! →  22

6.1 Quick wiring guide

Terminal assignment

NOTICE

Destruction or malfunction of parts of the electronics through ESD - electrostatic discharge.

- ▶ Take measures to protect the terminals from electrostatic discharge.

 To avoid incorrect measuring values an extension or compensation cable for direct wiring of thermocouple and RTD sensors for the signal transmission has to be used. The polarity indication on the respective terminal block and the wiring scheme has to be observed.

The planning and the installation of the bus connection cables of the plant is not to be concerned of the manufacturer of the device. Therefore the manufacturer cannot be considered to be responsible for possible damages due to the choice of materials that are not suitable for that application or to a faulty installation.

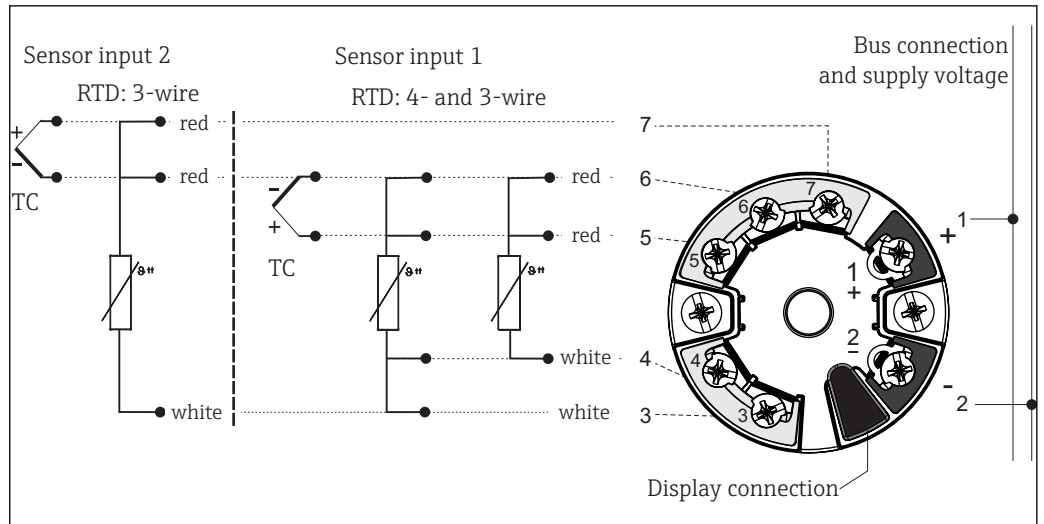

A0016711-EN

3 Wiring diagram of the dual sensor input head transmitters (TMT8x)

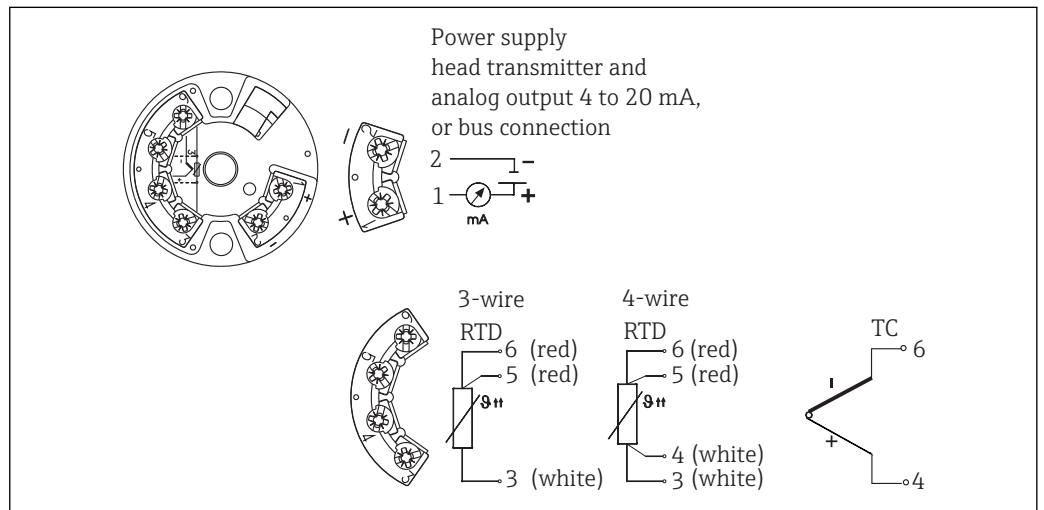

A0016712-EN

4 Wiring diagram of the single sensor input head transmitters (TMT18x)

Thermocouple cable colors

According to IEC 60584	According to ASTM E230
<ul style="list-style-type: none"> ▪ Type J: Black (+), white (-) ▪ Type K: Green (+), white (-) ▪ Type N: Pink (+), white (-) 	<ul style="list-style-type: none"> ▪ Type J: White (+), red (-) ▪ Type K: Yellow (+), red (-) ▪ Type N: Orange (+), red (-)

6.2 Connecting the sensor cables

i Each sensor is marked with an individual TAG number. As default configuration, all wires are always connected to the installed transmitters or terminals.

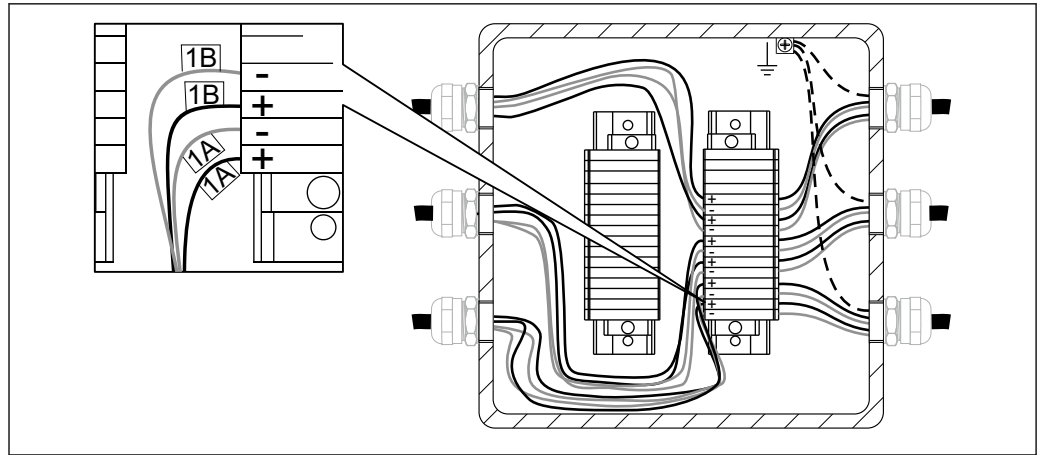

A0033289

5 Direct wiring on the mounted terminal block. Example for the internal sensor wires marking with 2 x TC sensors in insert no. 1.

The wiring is done in consecutive order, which means that the input channel(s) of transmitter no. 1 are connected to the insert wires starting from insert no. 1. Transmitter no. 2 is not used until all channels of transmitter no. 1 are fully connected. The wires of each insert are marked with consecutive numbers starting from 1. If double sensors are used the internal marking has a suffix to distinguish the two sensors, e.g. 1A and 1B for double sensors in the same insert or measuring point no. 1.

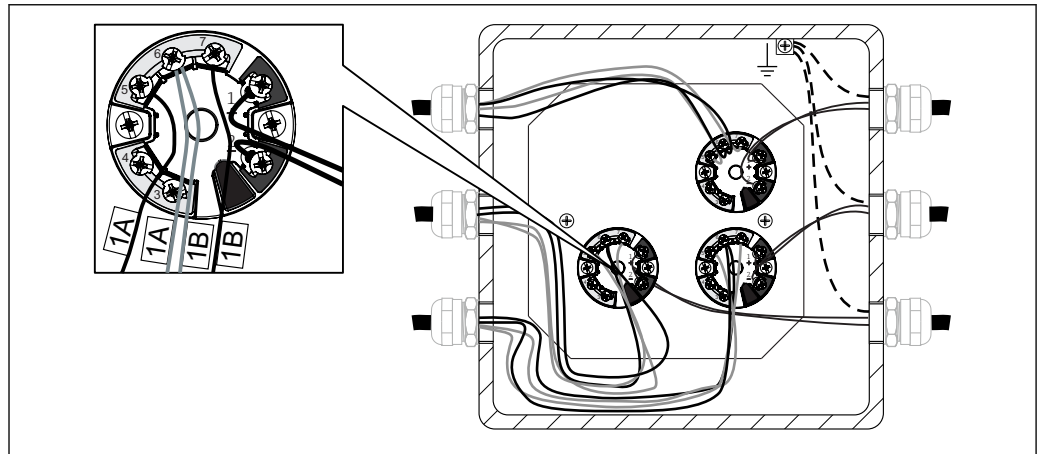

A0033289

6 Mounted and wired head transmitter. Example for the internal sensor wires marking with 2 x TC

Sensor type	Transmitter type	Wiring rule
1 x RTD or TC	<ul style="list-style-type: none"> ▪ Single input (one channel) ▪ Double input (two channels) ▪ Multi-channel input (8 channel) 	<ul style="list-style-type: none"> ▪ 1 Head transmitter per insert ▪ 1 Head transmitter for 2 inserts ▪ 1 Multi-channel transmitter for 8 inserts
2 x RTD or TC	<ul style="list-style-type: none"> ▪ Single input (one channel) ▪ Double input (two channels) ▪ Multi-channel input (8 channel) 	<ul style="list-style-type: none"> ▪ Not available, wiring excluded ▪ 1 Head transmitter per insert ▪ 1 Multi-channel transmitter for 4 inserts

6.3 Connecting the power supply and signal cables

Cable specification

- A shielded cable is recommended for fieldbus communication. Take the plant grounding concept into consideration.
- The terminals for connecting the signal cable (1+ and 2-) are protected against reverse polarity.
- Conductor cross-section:
 - Max 2.5 mm² (14 AWG) for screw terminals
 - Max 1.5 mm² (16 AWG) for spring terminals

Always observe the general procedure on →  18.

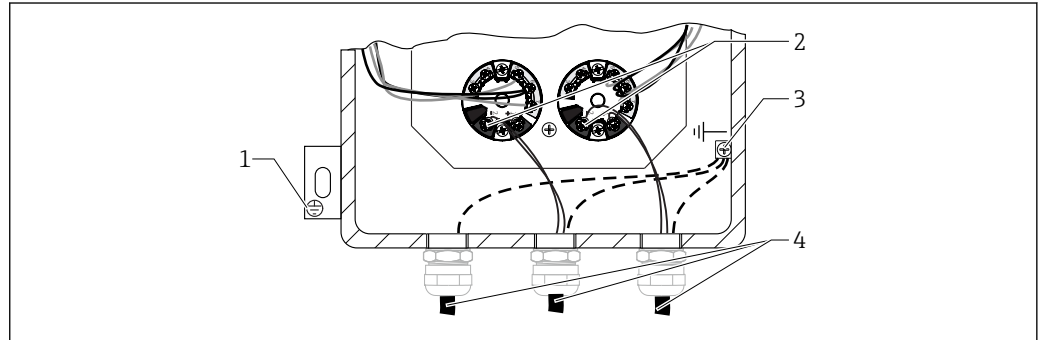

A0033290

 7 Connecting the signal cable and power supply to the installed transmitter

- 1 External ground terminal
- 2 Terminals for signal cable and power supply
- 3 Internal ground terminal
- 4 Shielded signal cable, recommended for fieldbus connection

6.4 Shielding and grounding

 For any specific electrical shielding and grounding regarding the transmitter wiring please refer to the appropriate operating manual of the installed transmitter.



Where applicable, national installation regulations and guidelines must be observed during the installation! Where there are large differences in potential between the individual grounding points, only one point of the shielding is connected directly with the reference ground. In systems without potential equalization, therefore, cable shielding of fieldbus systems should only be grounded on one side, for example at the supply unit or at safety barriers.

NOTICE

If the shielding of the cable is grounded at more than one point in systems without potential matching, power supply frequency equalizing currents can occur that damage the signal cable or have a serious effect on signal transmission.

- ▶ In such cases the shielding of the signal cable is to be grounded on only one side, i.e. it must not be connected to the ground terminal of the housing (terminal head, field housing). The shield that is not connected should be insulated!

6.5 Degree of protection

The device is conform to the requirements up to IP 66 ingress protection. In order to fulfil the degree of protection after installation or service, the following points must be taken into consideration: →  8,  22

- The housing seals must be clean and undamaged before they are replaced in the sealing rebate. If they are found to be too dry, they should be cleaned or even replaced.
- All housing screws and covers must be tightened.
- The cables used for connection must be of the correct specified outside diameter (e.g. M20 x 1.5, cable diameter from 0.315 to 0.47 in; 8 to 12 mm).
- Tighten cable gland.
- Loop the cable or conduit before placing into the entry ("Water sack"). This means that any moisture that may form cannot enter the gland. Install the device so that the cable or conduit entries are not facing upwards.
- Entries not used are to be blanked off using the blanking plates provided.
- The protective grommet must not be removed from the NPT fitting.

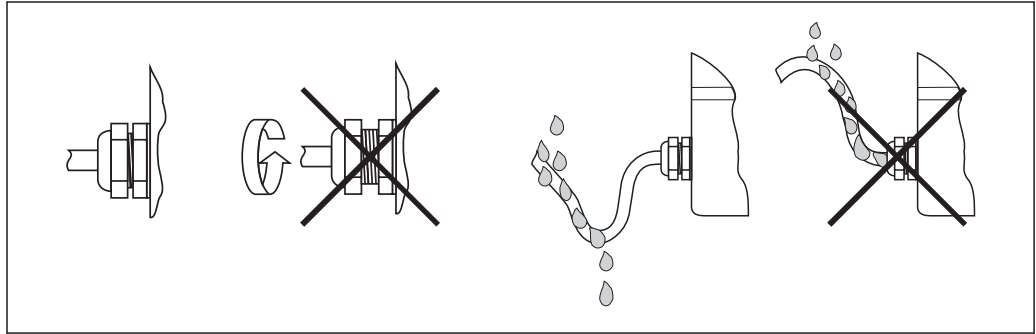

A0011260

8 Connection hints to maintain IP protection

6.6 Post-connection check

Is the device undamaged (internal equipment inspection)?	<input type="checkbox"/>
Electrical connection	
Does the supply voltage match the specifications on the nameplate?	<input type="checkbox"/>
Do the cables have adequate strain relief?	<input type="checkbox"/>
Are the power supply and signal cables correctly connected? → 18	<input type="checkbox"/>
Are all the screw terminals well tightened and have the connections of the spring terminals been checked?	<input type="checkbox"/>
Are all the cable glands installed, tightened and sealed?	<input type="checkbox"/>
Are all the housing covers installed and tightened?	<input type="checkbox"/>
Does the marking of the terminals and cables match?	<input type="checkbox"/>
Is the electrical continuity of the thermocouple verified?	<input type="checkbox"/>

7 Commissioning

7.1 Preliminaries

Set-up guidelines of Standard, Extended and Advanced Commissioning for Endress+Hauser instruments in order to guarantee the function of the instrument according to:

- Endress+Hauser operating manual
- Customer set up specification, and/or
- Application conditions, when applicable under process conditions

Both the operator and the person responsible for the process should be informed that a commissioning job will be carried out, observing the following actions:

- If applicable, before disconnecting any sensor that is attached to the process, determine what chemical or fluid is being measured (observe safety data sheet).
- Be aware of the temperature and pressure conditions.
- Never open a process fitting or loosen flange bolts before you have confirmed it is safe to do so.
- Be sure not to disturb the process when disconnecting inputs/outputs or when simulating signals.
- Ensure our tools, equipment and the customer process are protected from cross contamination. Consider and plan necessary cleaning steps.
- When commissioning requires chemicals (e.g. as reagents for standard operation or for cleaning purposes), always follow and observe the safety regulations.

7.1.1 Reference documents

- Endress+Hauser Standard Operating Procedure for Health and Safety (see documentation code: BP01039H)
- Operating Manual of relevant tools and equipment to perform the commissioning job.
- Relevant Endress+Hauser Service Documentation (operating manual, work instructions, service info, service manual, etc.).
- Calibration certificates of the quality relevant equipment if available.
- If applicable, safety data sheet.
- Customer specific documents (safety instructions, setup points, etc.).

7.1.2 Tools and equipment

Multimeter and instrument related configuration tools as necessary from the above mentioned action list.

7.2 Function check

Before commissioning the device make sure that all final checks have been carried out

- "Post-mounting check" checklist
- "Post-connection check" checklist

The commissioning should be performed according to our commissioning segmentation (Standard, Extended and Advanced).

7.2.1 Standard commissioning

Visual inspection of device

1. Check the instrument(s) for damage which may have been caused during transport/shipping or mounting/wiring
2. Check that the installation is done according to the operating manual

3. Check that the wiring is done according to the operating manual and the local regulations (e.g. grounding)
4. Check the dust/water tightness of the instrument(s)
5. Check safety precautions (e.g., radiometric measurements)
6. Power up the instrument(s)
7. Check the alarm list if applicable

Environmental conditions

1. Check that the environmental conditions are appropriate for the instrument(s): Ambient temperature, humidity (ingress protection IPxx), vibrations, hazardous areas (Ex, Dust-Ex), RFI/EMC, sun protection, etc.
2. Check access to the instrument(s) for utilization and maintenance

Configuration parameters

- ▶ Configure the instrument(s) according to the Operating Manual with the parameters specified by the customer or mentioned on the design specification

Output signal value check

- ▶ Check and confirm that the local display and the output signals of the instrument(s) conform with the customer's display

7.2.2 Extended commissioning

In addition to the steps of Standard Commissioning, the following should be additionally completed:

Instrument Conformity

1. Check the received instrument(s) with the purchase order or design specification including accessories, documentation and certificates
2. Check Software Version (e.g. application software such as "Batching") when provided
3. Check that the documentation has the correct issue and version

Functional test

1. Test of the instrument outputs, including switching points, auxiliary inputs/outputs with the internal or an external simulator (e.g. FieldCheck)
2. Compare the measuring data/results with a reference from the customer. (e.g. laboratory result in case of an analyzer, weight scale in the case of a batching application, etc.)
3. Adjust the instrument(s) if necessary and as described in the operating manual

7.2.3 Advanced commissioning

The Advanced Commissioning provides a loop test in addition to the steps covered in the Standard and Extended Commissioning.

Loop test

1. Simulate a minimum of 3 output signals from the instrument(s) to the control room
2. Read out/note the simulated and indicated values and check for linearity

7.3 Switching on the device

Once the final checks have been successfully completed, it is time to switch on the supply voltage. Afterwards the multipoint thermometer is operational. If there are Endress+Hauser temperature transmitter in use, please refer to the enclosed Brief Operating Instructions for commissioning.

8 Diagnostics and troubleshooting

8.1 General troubleshooting

For electronic, always start troubleshooting with the checklists available in the related operating manuals. This takes you directly (via various queries) to the cause of the problem and the appropriate remedial measures.

For the complete temperature device, please refer to the following instruction.

NOTICE

Repair of parts of the device

- ▶ In the event of a serious fault, a measuring device might have to be replaced. In the case of replacement see section 'Return' →  31.

Before commissioning the measuring system make sure that all final checks have been carried out:

- Follow the checklist in section 'Post-mounting check' →  16
- Follow the checklist in section 'Post-connection check'

If transmitters are used, please refer to the documentation of the transmitter installed for diagnostic and troubleshooting procedures →  48.

9 Maintenance and Repair

9.1 General notes

The accessibility around the device for maintenance has to be guaranteed. Each component that is part of the device must be – in the case of replacement – replaced by an original spare part of Endress+Hauser which guarantees the same characteristics and performance. To ensure continued operational safety and reliability it is suggested to carry out repairs on the device only if they are expressly permitted by Endress+Hauser, observing federal/national regulations pertaining to repair of an electrical device.

9.2 Spare parts

Spare parts currently available for the product can be found online at http://www.products.endress.com/spareparts_consumables.

When ordering spare parts, please specify the serial number of the unit!

Spare parts of the Multipoint thermometer assembly are:

- Complete junction box
- Temperature inserts (when applicable)
- Temperature transmitter
- Electric terminal
- DIN rail
- Plate for electric terminals
- Cable gland
- Sealing sleeve for cable gland
- Adapters for cable gland
- Junction box support system

The additional following accessories can be selected independently from the product configuration:

- Pressure transmitter
- Pressure manometer
- Fitting
- Manifolds
- Valves

In case of replaceable inserts design the following steps have to followed.

NOTICE

- ▶ Before starting any sensor replacement activity, it is mandatory to make sure that there is no pressure inside the primary thermowell, by checking the pressure value indicated by the pressure accessories (manometer or pressure transmitter) mounted on the pressure port.

In case of pressurized conditions, if only a pressure gauge/transmitter is installed, no sensors replacement is allowed.

NOTICE

- ▶ Please note that in case of pressure port absence, no direct maintenance on sensors is allowed, but only activities limited to the junction box components (cable glands, transmitters, terminal blocks, etc.).

When a pressure gauge/transmitter is mounted in combination with manifolds or multi-ways valves, then sensors can be replaced even in operating conditions after having performed the here listed safety actions:

1.

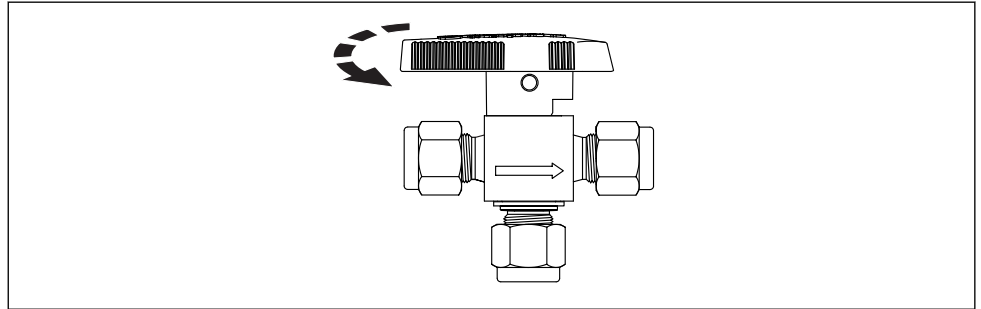

A0036098

Switch the multi-way valve in drain position (when possible keeping pressure indicator active).

2. Drain the fluids in a safe way to a blowdown line or by applying procedures in compliance with the local safety regulations.
3. Make sure that all the over pressure is released.
4. Switch the multi-way valve in the original position in pressure detection mode.
5. Monitor the pressure indicator for a reasonable period time (depending on the specific process conditions). Only when the pressure is not rising up again in a significant way (between 20-30 minutes), start with the following operations:

Case 1: Design with three pieces union joint (Intrinsically safe design)

1.

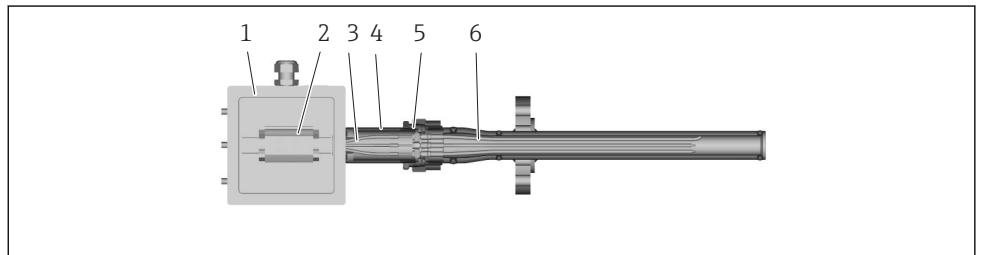

A0036099

Open the cover of the junction box (1).

2. Disconnect the sensor wires (3) of all the measuring inserts (6) from the terminal block (2), or transmitter, inside the junction box (process side).
3. Unscrew completely the hexagonal nut of the three pieces union joint (5).
4. Remove apart the junction box with its adaptor (4) till the complete bundle of sensors' extension wires and the compression fittings are accessible.
5. Unscrew the compression fitting nuts.
6. Slip off carefully the sensors taking care not damaging the compression fitting threads and sealing seats, slowly and completely.
7. Please note that the sealing metal ferrule of the unscrewed compression fitting must be replaced at each of this operation. A new set of metal ferrules are required to have the same specifications as the replaced part.
8. Lead in a new measuring insert through the compression fitting starting with the tip. The length and specifications of the measuring insert to replace (by Endress+Hauser) must meet the specifications of the replaced part.
9. Tight the nut of the compression fitting following the instructions of the manufacturer.
10. If necessary clean the components of the three pieces union, taking care to avoid any damages on its surface.
11. Reset the junction box in the original position and orientation taking care that the extension cable bundle is completely inserted into the junction box.

12. Screw and tighten the hexagonal nut of the three pieces union joint.
13. Properly connect all cables of the measuring insert, according to wiring scheme, to the relative terminal block or transmitter inside the junction box.
14. Close the housing cover.

Case 2: Design with direct mounted support frame (Explosion proof design)

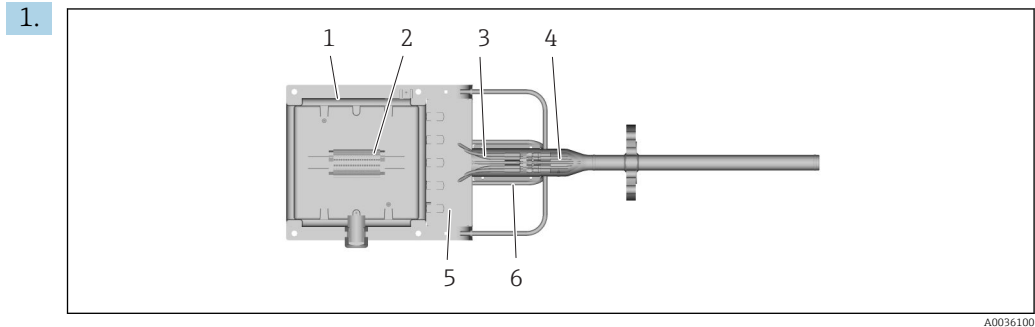

1. Open the cover of the junction box (1).
2. Disconnect the sensor wires (3) of the measuring insert (4) that has to be replaced (or the complete set in case of complete maintenance) from the terminal block (2) or transmitter inside the junction box (process side).
3. Remove the cable gland protection plate (5).
4. Remove the extension cables cover (6).
5. Unloose the cable gland sealing nut of the targeted insert (or all) and slip off the extension cables from the junction box.
6. Unscrew the compression fitting nuts.
7. Slip off carefully the sensor (or more sensors) taking care not damaging the compression fitting threads and sealing seats, slowly and completely.
8. Please note that the sealing metal ferrule of the unscrewed compression fitting must be replaced at each of this operation. A new set of metal ferrules are required to have the same specifications as the replaced part.
9. Lead in a new measuring insert through the compression fitting starting with the tip. The length and specifications of the measuring insert to replace (by Endress+Hauser) must meet the specifications of the replaced part.
10. Insert the extension cables of the replaced sensor inside its cable gland.
11. Tight the nut of the compression fitting following the instructions of the manufacturer.
12. Tight the cable gland sealing nut.
13. Properly connect all cables of the measuring insert, according to wiring scheme, to the relative terminal block or transmitter inside the junction box.
14. Remount the cable gland protection plate and the extension cables cover.
15. Close the housing cover.

Case 3: Design with remote junction box and protecting conduit (Explosion proof design)

1.

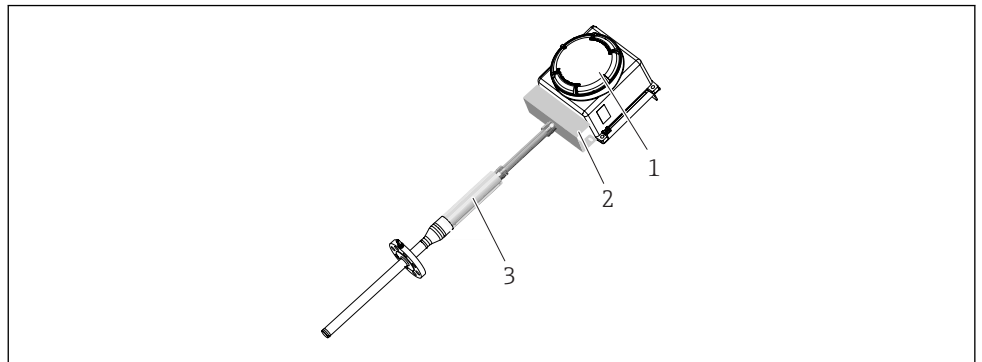

A0036101

Open the cover of the junction box (1).

2. Disconnect the sensor wires of all the measuring inserts that have to be replaced from the terminal blocks or transmitters inside the junction box (process side).
3. Disjoint the extension cables cover (2) from the junction box.
4. Open the cable conduit cover (3).
5. Unloose the cable gland sealing nuts of all the inserts and slip off the extension cables from the junction box.
6. Pullout the complete bundle of extension cables.
7. Remove completely the cable conduit covers.
8. Unscrew the compression fitting nuts.
9. Slip off carefully the sensor (or more sensors) taking care not damaging the compression fitting threads and sealing seats, slowly and completely.
10. Please note that the sealing metal ferrule of the unscrewed compression fitting must be replaced at each of this operation. A new set of metal ferrules are required to have the same specifications as the replaced part.
11. Slide-in the new set bundle of extension cables in the conduit.
12. Lead in all the new measuring inserts through the compression fittings starting with the tips. The length and specifications of each measuring insert to be replaced (by Endress+Hauser) must meet the specifications of the replaced part.
13. Insert the different extension cables of the new sensors inside their cable glands.
14. Tight the nut of the compression fitting following the instructions of the manufacturer.
15. Tight the cable gland sealing nut.
16. Properly connect all cables of the measuring insert, according to wiring scheme, to the relative terminal block or transmitter inside the junction box.
17. Remount the extension cable cover and the cable conduit covers.
18. Close the housing cover.

Case 4: Design with remote junction box and protecting conduit (Intrinsically safe design)

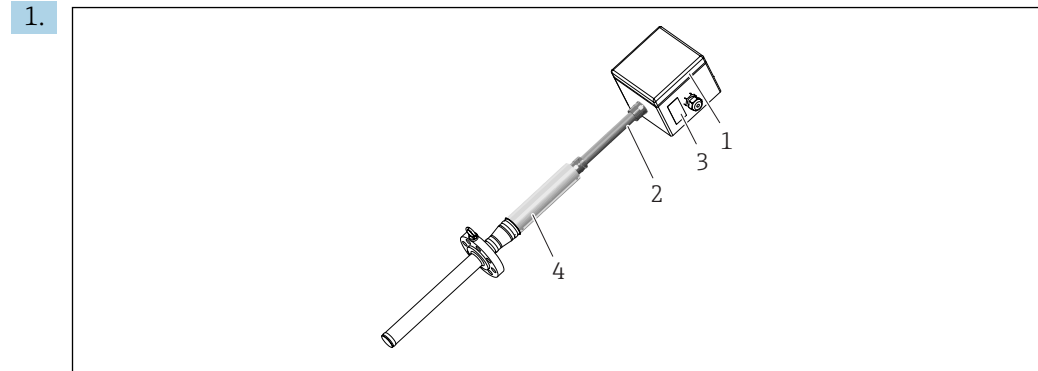

1. Open the cover of the junction box (1).
2. Disconnect the sensor wires of all the measuring inserts that have to be replaced from the terminal blocks or transmitters inside the junction box (process side).
3. Unloose the cable conduit (2) from the junction box (3).
4. Open the extension cables cover (4).
5. Pullout the complete bundle of extension cables.
6. Remove completely the extension cable covers (4).
7. Unscrew the compression fitting nuts.
8. Slip off carefully the sensor (or more sensors) taking care not damaging the compression fitting threads and sealing seats, slowly and completely.
9. Please note that the sealing metal ferrule of the unscrewed compression fitting must be replaced at each of this operation. A new set of metal ferrules are required to have the same specifications as the replaced part.
10. Slide-in the new set bundle of extension cables in the conduit.
11. Lead in all the new measuring inserts through the compression fittings starting with the tips. The length and specifications of each measuring insert to be replaced (by Endress+Hauser) must meet the specifications of the replaced part.
12. Tight the nut of the compression fitting following the instructions of the manufacturer.
13. Tight the cable conduit (2) to the junction box.
14. Properly connect all cables of the measuring insert, according to wiring scheme, to the relative terminal block or transmitter inside the junction box.
15. Remount the extension cables covers (4).
16. Close the housing cover.

9.3 Endress+Hauser services

Service	Description
Certifications	Endress+Hauser is able to fulfill requirements belonging to the design, product manufacturing, tests and commissioning according to specific approvals by handling or supplying individual certified components and by checking the integration on the whole system.
Maintenance	All Endress+Hauser systems are designed for an easy maintenance due to a modular design, allowing the replacement of old or wear out parts. Standardized parts ensure fast reaction for maintenance.

Service	Description
Calibration	Endress+Hauser's range of calibration services covers on-site verification tests, accredited laboratory calibrations, certificates and traceability to ensure compliance.
Installation	Endress+Hauser helps you commission plants while minimizing costs. Fault free installation is decisive for the quality and longevity of the measurement system and plant running. We provide the right expertise at the right time to meet project deliverables.
Tests	In order to ensure product quality and to guarantee efficiency during the entire lifetime the following tests are available: <ul style="list-style-type: none"> ▪ Dye penetration test according to ASME V art. 6, UNI EN 571-1 and ASME VIII Div. 1 App 8 standards ▪ PMI test according to ASTM E 572 ▪ HE test according to EN 13185 / EN 1779 ▪ X-ray test according to ASME V art. 2, art. 22 and ISO 17363-1 (requirements and methods) and ASME VIII div. 1 and to ISO 5817 (acceptance criteria). Thickness up to 30 mm ▪ Hydrostatic test according to PED Directive, EN 13445-5 and harmonized ▪ Ultrasonic test available by qualified external partners, according to ASME V Art. 4.

9.4 Return

The measuring device must be returned if it is need of repair or a factory calibration, or if the wrong measuring device has been delivered or ordered. Legal specifications require Endress+Hauser, as an ISO-certified company, to follow certain procedures when handling products that are in contact with the medium.

To ensure safe, swift and professional device returns, please refer to the procedure and conditions for returning devices provided on the Endress+Hauser website at <http://www.endress.com/support/return-material>

9.5 Disposal

9.5.1 Removing the measuring device

1. Switch off the device.

WARNING

Danger to persons from process conditions.

- ▶ Beware of hazardous process conditions such as pressure in the measuring device, high temperatures or aggressive fluids.
2. Carry out the mounting and connection steps from the "Mounting the measuring device" and "Connecting the measuring device" sections in reverse order. Observe the safety instructions.

9.5.2 Disposing of the measuring device

WARNING

Danger to personnel and environment from fluids that are hazardous to health.

- ▶ Ensure that the measuring device and all cavities are free of fluid residues that are hazardous to health or the environment, e.g. substances that have permeated into crevices or diffused through plastic.

Observe the following notes during disposal:

- ▶ Observe valid federal/national regulations.
- ▶ Ensure proper separation and reuse of the device components.

10 Accessories





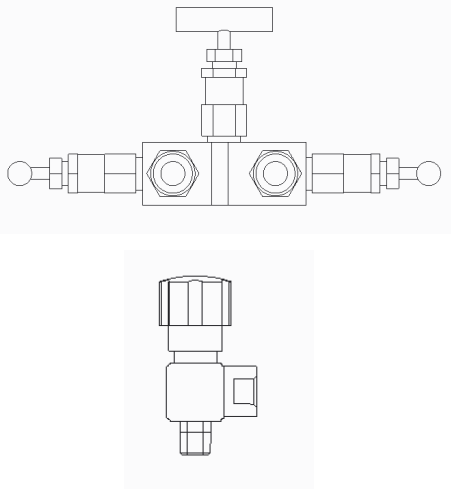
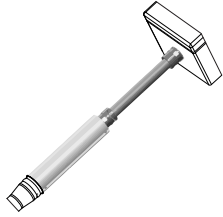

Various accessories, which can be ordered with the device or subsequently from Endress + Hauser, are available for the device. Detailed information on the order code is available from your local Endress+Hauser sales center.

10.1 Device-specific accessories

Accessories	Description
<p>Tags</p>	<p>Nameplate can be applied to identify each measuring points and the whole assembly. Tags can be placed on the extension cables in the extension area and/or in to the junction box on individual wires or on other device.</p>
<p>Pressure transducer</p>	<p>Digital or analogical pressure transmitter with welded metal sensor for measurement in gases, steam or liquids. Ref to Endress+Hauser PMP sensors family</p>
<div style="text-align: center;">  </div> <p style="text-align: right; font-size: small;">A0034865</p> <p>Fitting / manifolds / valves</p>	<p>Fitting, manifolds and valves are available for the installation of the pressure transmitter on the pressure port connection, and so allows the continuous monitoring of the device under the operating conditions.</p>
<div style="text-align: center;">  </div> <p style="text-align: right; font-size: small;">A0036534</p> <p>Remote cable conduit system</p>	<p>Composed by a polyamide cable conduit to connect the top of the top of the thermowell and the remote junction box, already provided of a shaped stainless steel cover fixed to the junction box frame to protect the cable connections.</p>

10.2 Communication-specific accessories

<p>Configuration kit TXU10</p>	<p>Configuration kit for PC-programmable transmitter with setup software and interface cable for PC with USB port Order code: TXU10-xx</p>
<p>Commubox FXA195 HART</p>	<p>For intrinsically safe HART communication with FieldCare via the USB interface.  For details, see "Technical Information" TI00404F</p>

Commubox FXA291	Connects Endress+Hauser field devices with a CDI interface (= Endress+Hauser Common Data Interface) and the USB port of a computer or laptop.  For details, see "Technical Information" TI00405C
HART Loop Converter HMX50	Is used to evaluate and convert dynamic HART process variables to analog current signals or limit values.  For details, see "Technical Information" TI00429F and Operating Instructions BA00371F
Wireless HART adapter SWA70	Is used for the wireless connection of field devices. The WirelessHART adapter can be easily integrated into field devices and existing infrastructures, offers data protection and transmission safety and can be operated in parallel with other wireless networks with minimum cabling complexity.  For details, see Operating Instructions BA061S
Fieldgate FXA320	Gateway for the remote monitoring of connected 4-20 mA measuring devices via a Web browser.  For details, see "Technical Information" TI00025S and Operating Instructions BA00053S
Fieldgate FXA520	Gateway for the remote diagnostics and remote configuration of connected HART measuring devices via a Web browser.  For details, see "Technical Information" TI00025S and Operating Instructions BA00051S
Field Xpert SFX100	Compact, flexible and robust industry handheld terminal for remote configuration and for obtaining measured values via the HART current output (4-20 mA).  For details, see Operating Instructions BA00060S

10.3 Service-specific accessories

Accessories	Description
Applicator	Software for selecting and sizing Endress+Hauser measuring devices: <ul style="list-style-type: none"> Calculation of all the necessary data for identifying the optimum measuring device: e.g. pressure loss, accuracy or process connections. Graphic illustration of the calculation results Administration, documentation and access to all project-related data and parameters over the entire life cycle of a project. Applicator is available: <ul style="list-style-type: none"> Via the Internet: https://portal.endress.com/webapp/applicator On CD-ROM for local PC installation.
W@M	Life cycle management for your plant W@M supports you with a wide range of software applications over the entire process: from planning and procurement, to the installation, commissioning and operation of the measuring devices. All the relevant device information, such as the device status, spare parts and device-specific documentation, is available for every device over the entire life cycle. The application already contains the data of your Endress+Hauser device. Endress+Hauser also takes care of maintaining and updating the data records. W@M is available: <ul style="list-style-type: none"> Via the Internet: www.endress.com/lifecyclemanagement On CD-ROM for local PC installation.
FieldCare	FDT-based plant asset management tool from Endress+Hauser. It can configure all smart field units in your system and helps you manage them. By using the status information, it is also a simple but effective way of checking their status and condition.  For details, see Operating Instructions BA00027S and BA00059S

11 Technical data

11.1 Input

Measured variable Temperature (temperature linear transmission behavior)

Measuring range

RTD:

Input	Designation	Measuring range limits
RTD as per IEC 60751	Pt100	-200 to +600 °C (-328 to +1 112 °F)

Thermocouple:

Input	Designation	Measuring range limits
Thermocouples (TC) as per IEC 60584, part 1 - using an Endress+Hauser - iTEMP temperature head transmitter	Type J (Fe-CuNi)	-210 to +720 °C (-346 to +1 328 °F)
	Type K (NiCr-Ni)	-270 to +1 150 °C (-454 to +2 102 °F)
	Type N (NiCrSi-NiSi)	-270 to +1 100 °C (-454 to +2 012 °F)
	Internal cold junction (Pt100) Cold junction accuracy: ± 1 K Max. sensor resistance: 10 kΩ	

11.2 Output

Output signal

Generally, the measured value can be transmitted in one of two ways:

- Directly-wired sensors - sensor measured values forwarded without a transmitter.
- Via all common protocols by selecting an appropriate Endress+Hauser iTEMP temperature transmitter. All the transmitters listed below are mounted directly in the junction box and wired with the sensory mechanism.

Family of temperature transmitters

Thermometers fitted with iTEMP transmitters are an installation-ready complete solution to improve temperature measurement by significantly increasing accuracy and reliability, when compared to direct wired sensors, as well as reducing both wiring and maintenance costs.

PC programmable head transmitters

They offer a high degree of flexibility, thereby supporting universal application with low inventory storage. The iTEMP transmitters can be configured quickly and easily at a PC. Endress+Hauser offers free configuration software which can be downloaded from the Endress+Hauser Website. More information can be found in the Technical Information.

HART® programmable head transmitters

The transmitter is a 2-wire device with one or two measuring inputs and one analog output. The device not only transfers converted signals from resistance thermometers and thermocouples, it also transfers resistance and voltage signals using HART® communication. It can be installed as an intrinsically safe apparatus in Zone 1 hazardous areas and is used for instrumentation in the terminal head (flat face) as per DIN EN 50446. Swift and easy operation, visualization and maintenance by PC using operating software, Simatic PDM or AMS. For more information, see the Technical Information.

PROFIBUS® PA head transmitters

Universally programmable head transmitter with PROFIBUS® PA communication. Conversion of various input signals into digital output signals. High accuracy over the complete ambient temperature range. Swift and easy operation, visualization and

maintenance using a PC directly from the control panel, e. g. using operating software, Simatic PDM or AMS. For more information, see the Technical Information.

FOUNDATION Fieldbus™ head transmitters

Universally programmable head transmitter with FOUNDATION Fieldbus™ communication. Conversion of various input signals into digital output signals. High accuracy over the complete ambient temperature range. Swift and easy operation, visualization and maintenance using a PC directly from the control panel, e.g. using operating software such as ControlCare from Endress+Hauser or NI Configurator from National Instruments. For more information, see the Technical Information.

Advantages of the iTEMP transmitters:

- Dual or single sensor input (optionally for certain transmitters)
- Unsurpassed reliability, accuracy and long-term stability in critical processes
- Mathematical functions
- Monitoring of the thermometer drift, sensor backup functionality, sensor diagnostic functions
- Sensor-transmitter matching for dual sensor input transmitter, based on Callendar/Van Dusen coefficients

11.3 Performance characteristics

Accuracy RTD resistance thermometer as per IEC 60751

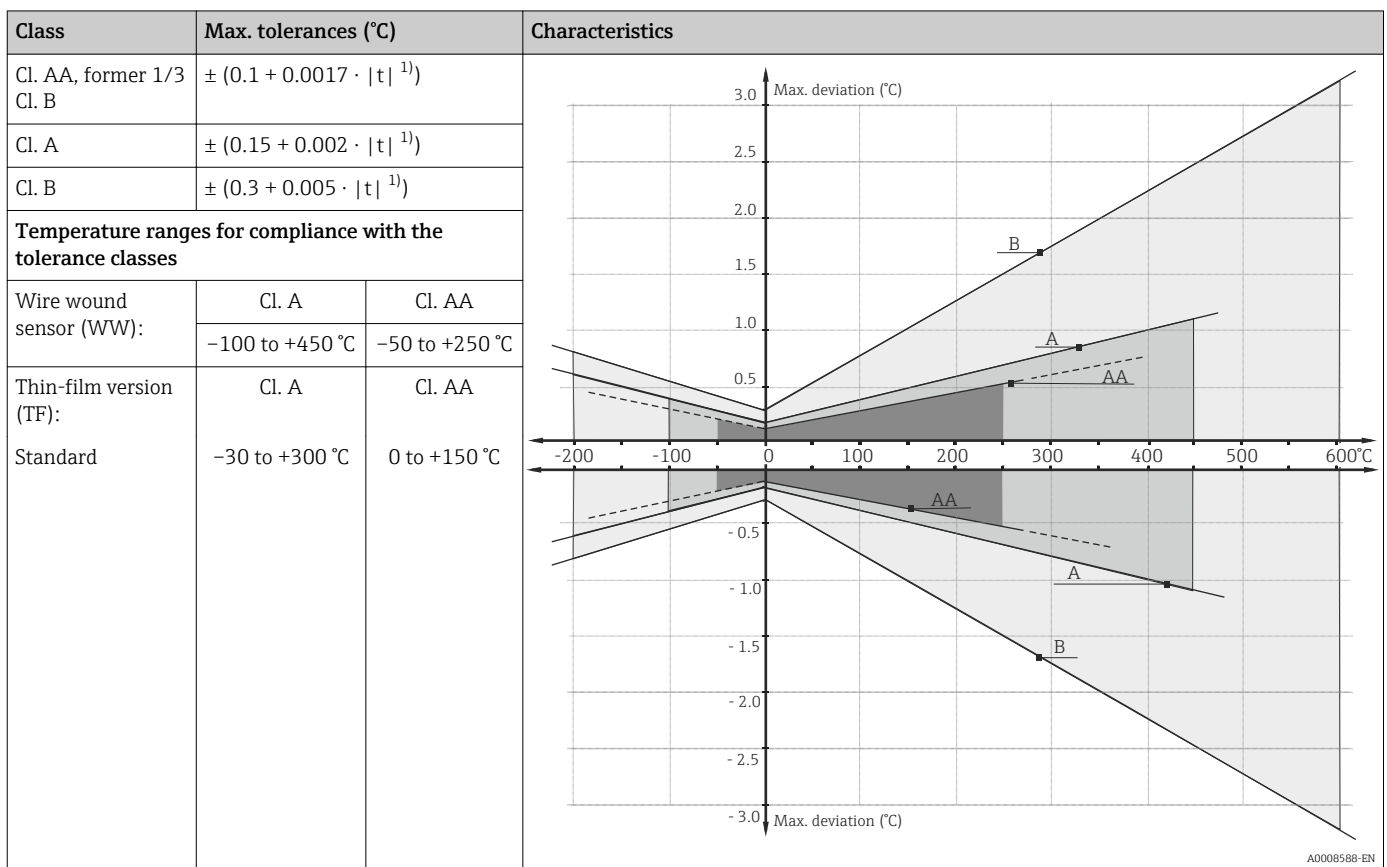

1) |t| = absolute value °C

In order to obtain the maximum tolerances in °F, the results in °C must be multiplied by a factor of 1.8.

Permissible deviation limits of thermoelectric voltages from the standard characteristic for thermocouples as per IEC 60584 or ASTM E230/ANSI MC96.1:

Standard	Type	Standard tolerance		Special tolerance	
		Class	Deviation	Class	Deviation
IEC 60584	J (Fe-CuNi)	2	$\pm 2.5 \text{ }^\circ\text{C}$ (-40 to 333 $^\circ\text{C}$) $\pm 0.0075 t ^{1)}$ (333 to 750 $^\circ\text{C}$)	1	$\pm 1.5 \text{ }^\circ\text{C}$ (-40 to 375 $^\circ\text{C}$) $\pm 0.004 t ^{1)}$ (375 to 750 $^\circ\text{C}$)
	K (NiCr-NiAl) N (NiCrSi-NiSi)	2	$\pm 2.5 \text{ }^\circ\text{C}$ (-40 to 333 $^\circ\text{C}$) $\pm 0.0075 t ^{1)}$ (333 to 1200 $^\circ\text{C}$)	1	$\pm 1.5 \text{ }^\circ\text{C}$ (-40 to 375 $^\circ\text{C}$) $\pm 0.004 t ^{1)}$ (375 to 1000 $^\circ\text{C}$)

1) |t| = absolute value $^\circ\text{C}$

Standard	Type	Standard tolerance		Special tolerance	
		Deviation, the larger respective value applies			
ASTM E230/ANSI MC96.1	J (Fe-CuNi)	$\pm 2.2 \text{ K}$ or $\pm 0.0075 t ^{1)}$ (0 to 760 $^\circ\text{C}$)		$\pm 1.1 \text{ K}$ or $\pm 0.004 t ^{1)}$ (0 to 760 $^\circ\text{C}$)	
	K (NiCr-NiAl) N (NiCrSi-NiSi)	$\pm 2.2 \text{ K}$ or $\pm 0.02 t ^{1)}$ (-200 to 0 $^\circ\text{C}$) $\pm 2.2 \text{ K}$ or $\pm 0.0075 t ^{1)}$ (0 to 1260 $^\circ\text{C}$)		$\pm 1.1 \text{ K}$ or $\pm 0.004 t ^{1)}$ (0 to 1260 $^\circ\text{C}$)	

1) |t| = absolute value $^\circ\text{C}$

Response time

i Response time for the sensor assembly without transmitter. When response time of the complete assembly is requested (including primary thermowell), a dedicated calculation depending on the sensor layout will be preformed.

RTD

Calculated at an ambient temperature of approx. 23 $^\circ\text{C}$ by immersing the insert in running water (0.4 m/s flow rate, 10 K excess temperature):

Insert diameter	Response time	
As an example, in case of thermowell thickness, 3.6 mm (0.14 in), bent guiding tubes design	t_{90}	108 s

Thermocouple (TC)

Calculated at an ambient temperature of approx. 23 $^\circ\text{C}$ by immersing the insert in running water (0.4 m/s flow rate, 10 K excess temperature):

Insert diameter	Response time	
As an example, in case of thermowell thickness, 3.6 mm (0.14 in), bent guiding tubes design	t_{90}	52 s

Shock and vibration resistance

- RTD: 3G / 10 to 500 Hz according to IEC 60751
- TC: 4G / 2 to 150 Hz according to IEC 60068-2-6

Calibration

Calibration is a service that can be performed on each individual insert, either in order phase, or after multipoint installation (only in case of replaceable sensors).

i When calibration shall be performed once the multipoint is installed, please contact the Endress+Hauser service to get full support. Together with the Endress +Hauser service any further activity can be organised to achieve the calibration of the target sensor. In any case it is forbidden to unscrew any threaded component on the process connection under operating conditions (running process), without knowing the pressure inside the primary thermowell.

Calibration involves comparing the measured values of the sensing elements of the multipoint inserts (DUT device under test) with those of a more precise calibration standard using a defined and reproducible measurement method. The aim is to determine the deviation of the DUT measured values from the true value of the measured variable.

Two different methods are used for the inserts:

- Calibration at fixed-point temperatures, e.g. at the freezing point of water at 0 °C (32 °F).
- Calibration compared against a precise reference thermometer.

i **Evaluation of inserts**

If a calibration with an acceptable uncertainty of measurement and transferable measurement results is not possible, Endress+Hauser offers an insert evaluation measurement service, if technically feasible.

11.4 Environment

Ambient temperature range

Junction box	Non-hazardous area	Hazardous area
Without mounted transmitter	-50 to +85 °C (-58 to +185 °F)	-50 to +60 °C (-58 to +140 °F)
With mounted head transmitter	-40 to +85 °C (-40 to +185 °F)	Depends on the respective hazardous area approval. Details see Ex documentation.
With mounted multi-channel transmitter	-40 to +85 °C (-40 to +185 °F)	-40 to +70 °C (-40 to +158 °F)

Storage temperature

Junction box	
With head transmitter	-50 to +100 °C (-58 to +212 °F)
With multi-channel transmitter	-40 to +80 °C (-40 to +176 °F)
With DIN rail transmitter	-40 to +100 °C (-40 to +212 °F)

Humidity

Condensation according to IEC 60068-2-33:

- Head transmitter: Permitted
- DIN rail transmitter: Not permitted

Maximum relative humidity: 95% according to IEC 60068-2-30

Climate class

Determined when the following components are installed into the junction box:

- Head transmitter: Class C1 according to EN 60654-1
- Multi-channel transmitter: Tested as per IEC 60068-2-30, meets the requirements regarding class C1-C3 in accordance with IEC 60721-4-3
- Terminal blocks: Class B2 according to EN 60654-1

Electromagnetic compatibility (EMC)

Depending on the head transmitter used. For detailed information see the related Technical Information, listed at the end of this document. →  48

11.5 Mechanical construction

Design, dimensions

The overall multipoint assembly is composed of different sub-assemblies. Different inserts are available, based upon specific process conditions, in order to have the highest accuracy and an extended lifetime. The primary thermowell should be selected to increase mechanical performances and corrosion resistance. Associated shielded extension cables are available with high resistance sheath materials to withstand different environmental conditions and to ensure steady and noiseless signals. The transition between the inserts and the extension cable is obtained by the usage of specially sealed bushings, ensuring the declared IP degree protection.

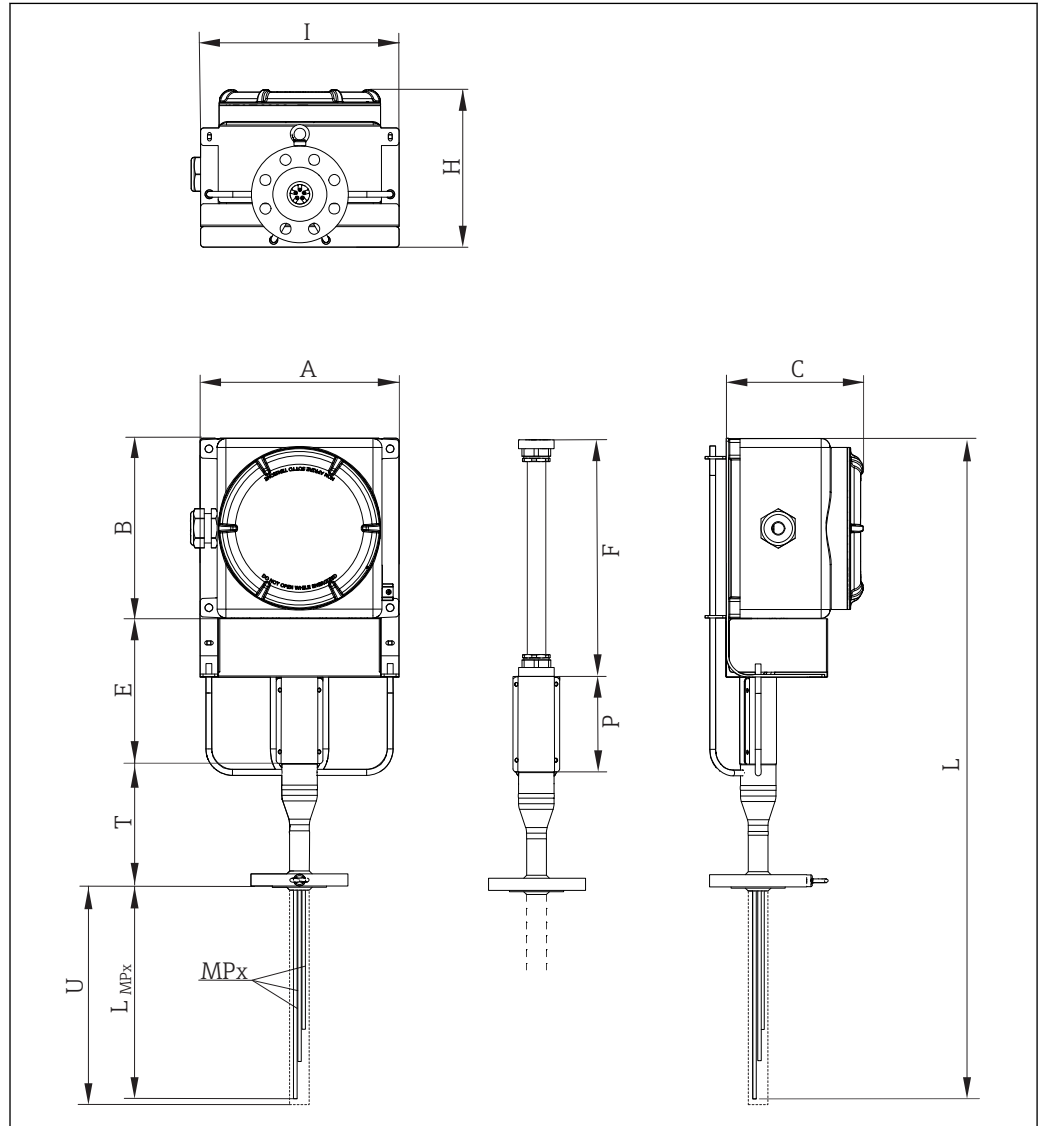

A0036092

9 Design of the modular multipoint thermometer, with frame neck. All dimensions in mm (in)

A, B, Dimensions of the junction box, see following figure

C

MPx Numbers and distribution of measuring points: MP1, MP2, MP3 etc.

L_{MPx} Immersion length of sensing elements or protecting thermowells

I, H Encumbrance of the junction box and support system

E Extension length

L Device length

T Lagging length

U Immersion length

P Protection: 250 mm

F Flexible hose length

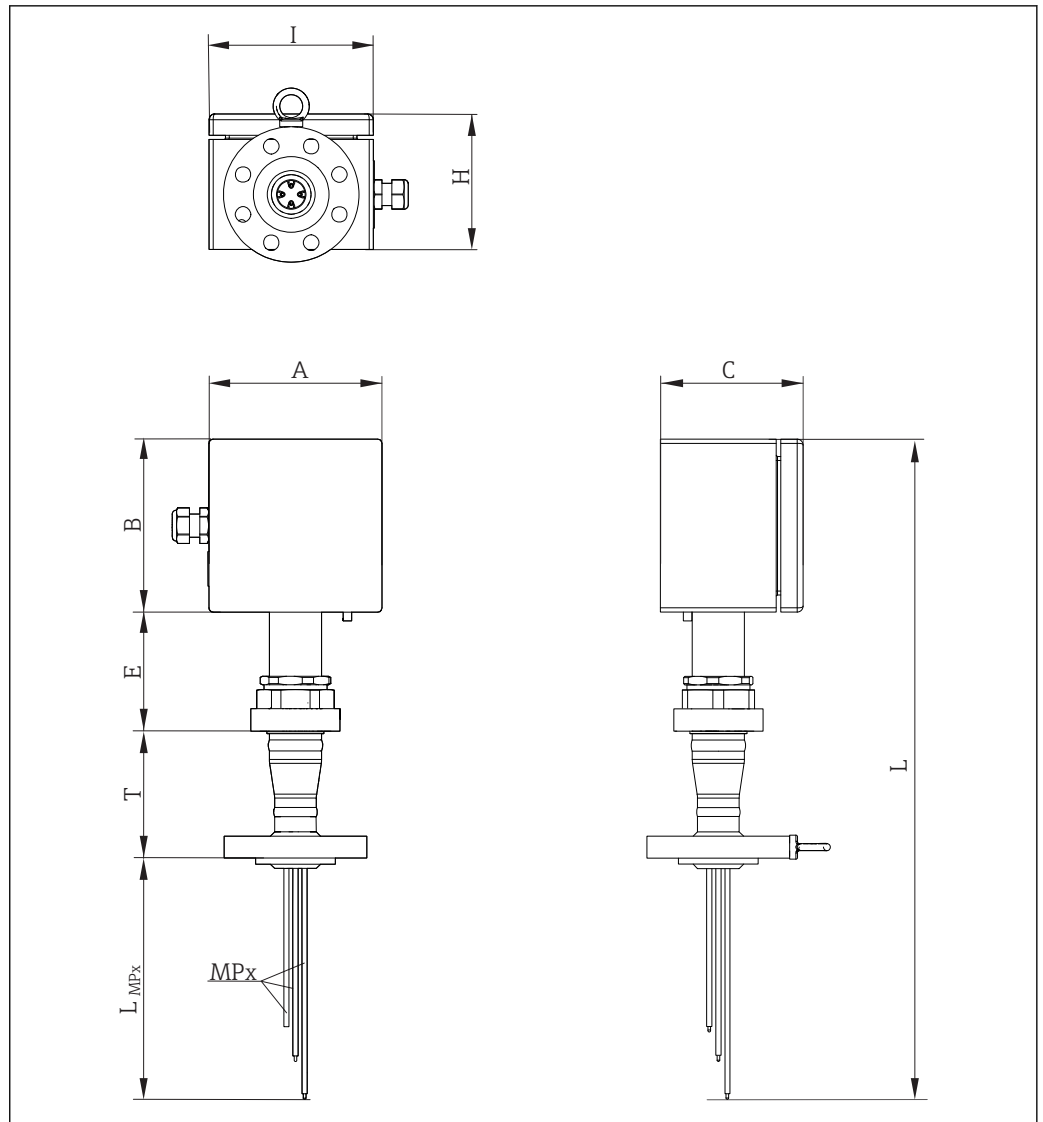

A0036093

10 Design of the modular multipoint thermometer, with tube neck design. All dimensions in mm (in)

A, B, Dimensions of the junction box, see following figure

C

MPx Numbers and distribution of measuring points: MP1, MP2, MP3 etc.

L_{MPx} Immersion length of sensing elements or protecting thermowells

I, H Encumbrance of the junction box and support system

E Extension length

L Device length

T Lagging length

U Immersion length

Junction box

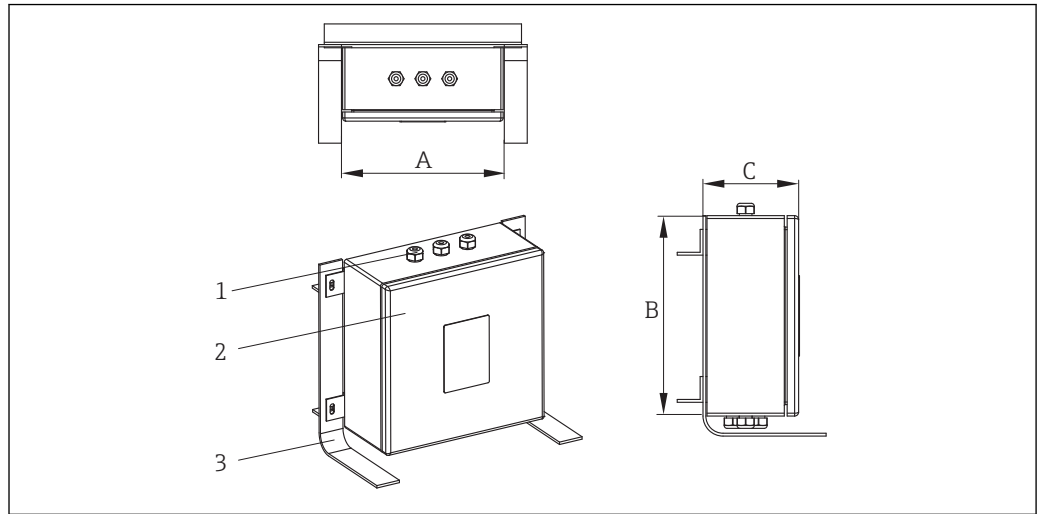

A0028118

- 1 Cable glands
- 2 Junction box
- 3 Frame

The junction box is suited for chemical agents environments. Sea water corrosion resistance and extreme temperature variation stability is guaranteed. Ex-e Ex-i terminals can be installed.

Possible junction box dimensions (A x B x C) in mm (in):

A	B	C
150 (5.9)	150 (5.9)	100 (3.93)
200 (7.87)	200 (7.87)	160 (6.29)
270 (10.6)	270 (10.6)	160 (6.29)
270 (10.6)	350 (13.78)	160 (6.29)
350 (13.78)	350 (13.78)	160 (6.3)
350 (13.78)	500 (19.68)	160 (6.3)
500 (19.68)	500 (19.68)	160 (6.3)
280 (11.02)	305 (12)	228 (8.98)
420 (16.53)	420 (16.53)	285 (11.22)
332 (13.07)	332 (13.07)	178 (7)
330 (12.99)	495 (19.49)	171 (6.73)

Type of specification	Junction box	Cable glands
Material	AISI 316 / Aluminium	NiCr Plated brass AISI 316 / 316L
Ingress protection (IP)	IP66/67	IP66
Ambient temperature range	-50 to +60 °C (-58 to +140 °F)	-52 to +110 °C (-61.1 to +140 °F)
Approvals	ATEX approval for use in hazardous area	ATEX approval for use in hazardous area

Type of specification	Junction box	Cable glands
Marking	<ul style="list-style-type: none"> ▪ ATEX II 2GD Ex e IIC/ Ex ia Ga IIC Ex tb IIIC Db T6/T5/T4 ▪ IECEX II 2GD Ex e IIC/ Ex ia Ga IIC Ex tb IIIC Db T6/T5/T4 ▪ IECEX II 2GD Ex e IIC/ Ex ia Ga IIC Ex tb IIIC Db T6/T5/T4 ▪ ATEX II 2GD Ex d IIC T6-T3/Ex tDA21 IP66 T85oC-T200oC ▪ IECEX II 2GD Ex d IIC T6-T3/ Ex tDA21 IP66 T85oC-T200oC ▪ UL913 Class I, Division 1 Groups B, C, D T6/T5/T4 ▪ FM3610 Class I, Division 1 Groups B, C, D T6/T5/T4 ▪ CSA C22.2 No. 157 Class I, Division 1 Groups B, C, D T6/T5/T4 	→ ☰ 42
Cover	Hinged and threaded	-
Maximum sealing diameter	-	6 to 12 mm (0.24 to 0.47 in)

Support system

A modular system or a union joint is foreseen in case of direct mounted junction box.

It ensures the connection between the head of the primary thermowell and the junction box. The system design ensures easy access for monitoring and maintaining inserts and extension cables. Rods and protection cover guarantee a high stiffness connection for the junction box and vibration loads. No closed volumes are present in the frame design although it allows protection to the cables. This avoids the accumulation of waste and potentially dangerous fluids coming from the environment that can damage the instrumentation allowing continuous ventilation.

In case of three pieces union joint design the junction box can be orientated and the extension cables remain accessible thanks to the disassembling of the joint.

Inserts, guiding tubes and protecting thermowells

Thermocouple

Diameter in mm (in)	Type	Standard	Hot junction type	Sheath material
3 (0.12)	1x type K 2x type K 1x type J 2x type J 1x type N 2x type N	IEC 60584 /ASTM E230	Grounded/Ungrounded	Alloy600 / AISI 316L / Pyrosil

Conductor thickness

Sensor Type	Diameter in mm (in)	Wall	Min. Sheath Thickness (S)	Min. Conductors Diameter (C)
Single Thermocouple	3 mm (0.11 in)	Standard	0.3 mm (0.01 in)	0,45 mm = 25 AWG
Double Thermocouple	3 mm (0.11 in)	Standard	0.27 mm (0.01 in)	0,33 mm = 28 AWG

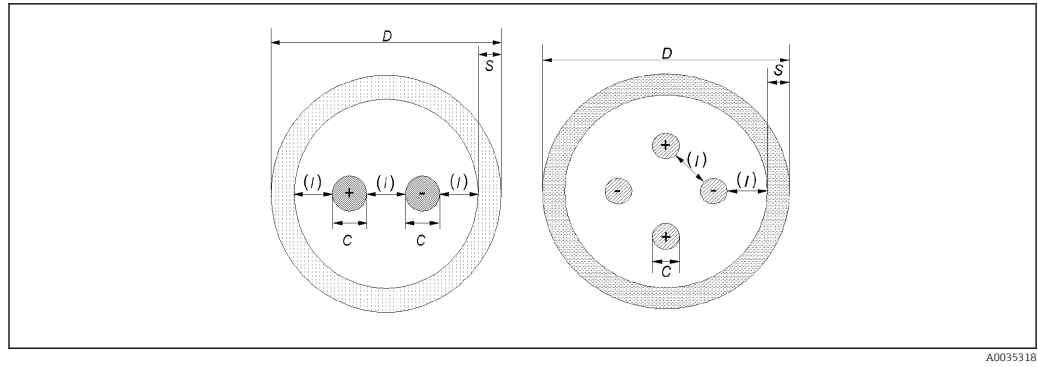

A0035318

RTD

Diameter in mm (in)	Type	Standard	Sheath material
3 (0.12)	1x Pt100 WW/TF	IEC 60751	AISI 316L

Protecting thermowells or guiding tubes

External diameter in mm (in)	Sheath material	Type	Thickness in mm (in)
6 (0.24)	AISI 316L	closed or open	0.5 (0.02) or 1 (0.04)
8 (0.32)	AISI 316L	closed or open	1 (0.04)

Sealing components

The sealing components (compression fittings) are welded on the thermowell head to guarantee proper tightness under all the foreseen operating conditions and to allow the maintenance/replacement of the sensors (when applicable).

Material: AISI 316/AISI 316H

Cable Glands

Installed cable glands provide the proper level of reliability under the mentioned ambient and operating conditions.

Material	Marking	IP Rating	Ambient T range	Max. sealing diameter
NiCr Plated brass	Atex II 2/3 GD Ex d IIC, Ex e II, Ex nR II, Ex tD A21 IP66	IP66	-52 to +110 °C (-61.6 to +230 °F)	6 to 12 mm (0.23 to 0.47 in)
AISI 316/AISI 316L	Atex II 2G, II 1D, Ex d IIC Gb, Ex e IIC Gb, Ex ta IIIC Da, II 3G Ex nR IIC Gc	IP66	-52 to +110 °C (-61.6 to +230 °F)	6 to 12 mm (0.23 to 0.47 in)

Diagnostic function

The reactors where the multipoint assembly operates are usually characterized by severe conditions in terms of pressure, temperature, corrosion and dynamics of the process fluids. Thanks to the pressure port, it is possible to detect and monitor possible leakages (or gases permeation) occurring through the primary thermowell, and plan the maintenance.

Weight

The weight can vary based upon the configuration, depending on the junction box and the frame design. The approximate weight of a typically configured multipoint thermometer (number of inserts = 12, main body = 3", medium size junction box) = 30 kg (66.1 lb).

The eyebolt, which is part of the process connection, must be used as the only lifting component to move the entire device.

Materials

The listed material properties have to be taken into account when selected for wetted parts:

Material name	Short form	Recommended max. temperature for continuous use in air	Properties
AISI 316/1.4401	X2CrNiMo17-12-2	650 °C (1202 °F)	<ul style="list-style-type: none"> ▪ Austenitic, stainless steel ▪ High corrosion resistance in general ▪ Particularly high corrosion resistance in chlorine-based and acidic, non-oxidizing atmospheres through the addition of molybdenum (e.g. phosphoric and sulfuric acids, acetic and tartaric acids with a low concentration)
AISI 316L/ 1.4404 1.4435	X2CrNiMo17-12-2 X2CrNiMo18-14-3	650 °C (1202 °F)	<ul style="list-style-type: none"> ▪ Austenitic, stainless steel ▪ High corrosion resistance in general ▪ Particularly high corrosion resistance in chlorine-based and acidic, non-oxidizing atmospheres through the addition of molybdenum (e.g. phosphoric and sulfuric acids, acetic and tartaric acids with a low concentration) ▪ Increased resistance to intergranular corrosion and pitting ▪ Compared to 1.4404, 1.4435 has even higher corrosion resistance and a lower delta ferrite content
INCONEL® 600 / 2.4816	NiCr15Fe	1100 °C (2012 °F)	<ul style="list-style-type: none"> ▪ A nickel/chromium alloy with very good resistance to aggressive, oxidizing and reducing atmospheres, even at high temperatures. ▪ Resistant to corrosion caused by chlorine gas and chlorinated media as well as many oxidizing mineral and organic acids, sea water etc. ▪ Corrosion from ultrapure water. ▪ Not to be used in a sulfur-containing atmosphere.
AISI 304/1.4301	X5CrNi18-10	850 °C (1562 °F)	<ul style="list-style-type: none"> ▪ Austenitic, stainless steel ▪ Well usable in water and lowly pollute waste water ▪ Only at relatively low temperatures resistant to organic acids, saline solutions, sulphates, alkaline solutions, etc.
AISI 316Ti/ 1.4571	X6CrNiMoTi17-12-2	700 °C (1292 °F)	<ul style="list-style-type: none"> ▪ Properties comparable to AISI316L. ▪ Addition of titanium means increased resistance to intergranular corrosion even after welding ▪ Broad range of uses in the chemical, petrochemical and oil industries as well as in coal chemistry ▪ Can only be polished to a limited extent, titanium streaks can form

Material name	Short form	Recommended max. temperature for continuous use in air	Properties
AISI 321/1.4541	X6CrNiTi18-10	815 °C (1499 °F)	<ul style="list-style-type: none"> ▪ Austenitic stainless steel ▪ High resistance to intergranular corrosion even after welding ▪ Good welding characteristics, suitable to all standard welding methods ▪ It is used in many sectors of the chemical industry, petrochemical, and pressurized vessels
AISI 347/1.4550	X6CrNiNb10-10	800 °C (1472 °F)	<ul style="list-style-type: none"> ▪ Austenitic stainless steel ▪ Good resistance to a wide variety of environments in the chemical, textile, oil-refining, dairy and food industries ▪ Added niobium makes this steel impervious to intergranular corrosion ▪ Good weldability ▪ Main applications are furnace fire walls, pressure vessels, welded structures, turbine blades

Process connection

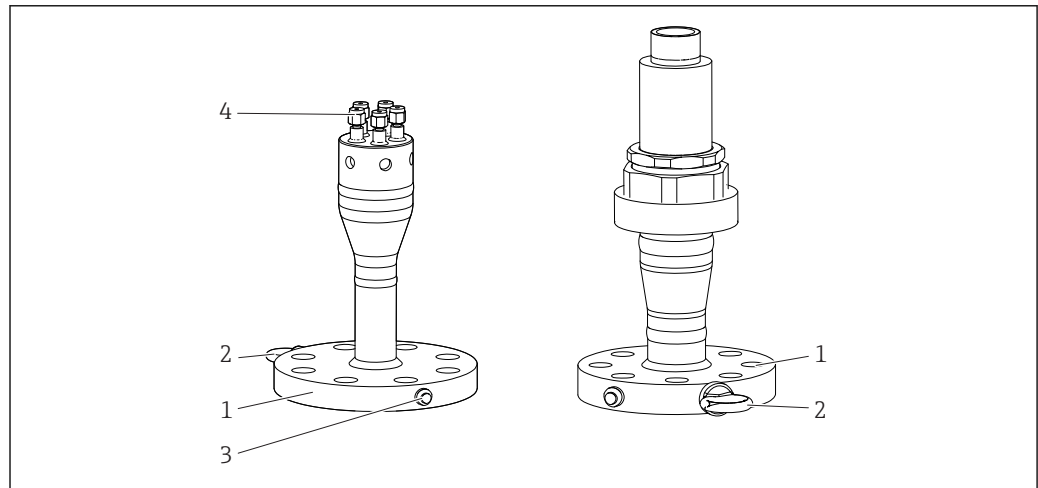

A0036094

11 Flange as process connection

- 1 Flange
- 2 Eyebolt
- 3 Pressure port
- 4 Compression fittings

Standard process connection flanges are designed according to the following standards:

Standard ¹⁾	Size	Rating	Material
ASME	1 1/2", 2", 3"	150#, 300#, 400#, 600#, 900#	AISI 316/L, 304/L, 310L, 321
EN	DN40, DN50, DN80	PN10, PN16, PN25, PN 40, PN 63, PN100, PN150	316/1.4401, 316L/1.4404, 321/1.4541, 310L/1.4845, 304/1.4301, 304L/1.4307

1) Flanges according to GOST standard are available on request.

Compression fittings

The compression fittings are welded onto the thermowell head to ensure the sensors replacement(when applicable). Dimensions are coherent with the insert dimensions. Compression fittings comply with the highest standards of reliability in terms of materials and performances required

Material	AISI 316/316H
-----------------	---------------

Thermal contact components

<p>A: Thermal contact block</p> <p>1 Guiding tube 2 Spacer 3 Insert 4 Thermal block 5 Primary thermowell wall</p> <p style="text-align: right;">A0036153</p>	<p>The thermal blocks are forced against the internal wall to ensure the optimal heat transfer between the primary thermowell and the replaceable temperature sensor</p>
<p>B: Bent guiding tubes and spacers</p> <p>1 Spacer 2 Guiding tube 3 Insert</p> <p style="text-align: right;">A0028783</p>	<ul style="list-style-type: none"> ▪ Allow sensor replacement ▪ Guarantee thermal contact between the sensor tip and the existing thermowell
<p>C: Protecting thermowells and spacers</p> <p>1 Protection thermowell 2 Spacer 3 Insert 4 Primary thermowell wall</p> <p style="text-align: right;">A0036632</p>	<p>Each sensor is protected by its protecting thermowell with straight tip</p>

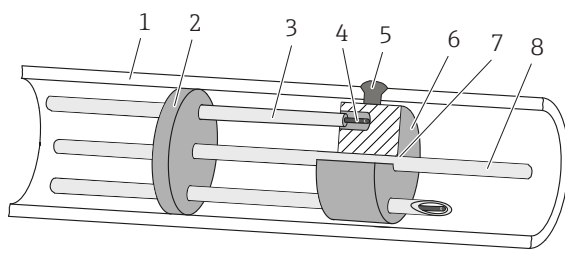
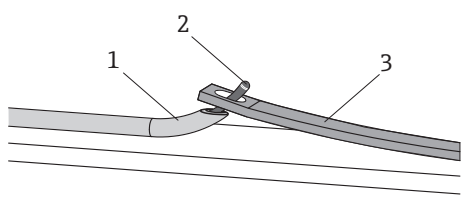
<p>D: Thermal block disc (welded to the primary thermowell)</p>  <p style="text-align: right;">A0036155</p> <ol style="list-style-type: none"> 1 Primary thermowell wall 2 Spacer 3 Guiding tube 4 Insert 5 Welded contact 6 Thermal block disc 7 Welding seam 8 Supporting rod 	<ul style="list-style-type: none"> ■ Ensure the optimal heat transfer thorough the primary thermowell wall and the temperature sensors. Sensors are replaceable ■ Sensors can be replaced
<p>E: Bimetallic stripes</p>  <p style="text-align: right;">A0028435</p> <p>☑ 12 Bimetal strips with or without guiding tubes</p> <ol style="list-style-type: none"> 1 Guiding tube 2 Insert 3 Bimetallic stripe 	<ul style="list-style-type: none"> ■ Doesn't allow sensor replacement ■ Guarantee thermal contact between the sensor tip and the thermowell due to bimetallic stripes activated by temperature difference ■ No friction during installation even with already installed sensors

11.6 Certificates and approvals

CE Mark	The complete assembly is provided with individual components CE marked, to ensure safe use in hazardous areas and pressurized environments.
Hazardous area approvals	<p>The Ex approval applies to individual components like junction box, cable glands, terminals. For further details on the available Ex versions (ATEX, UL, FM, CSA, IEC-EX, NEPSI, EAC-EX), please contact your nearest Endress+Hauser sales organization. All relevant data for hazardous areas can be found in separate Ex documentation.</p> <p>ATEX Ex ia inserts are available only for diameters ≥ 1.5 mm (0.6 in). For further details contact an Endress+Hauser technician.</p>
PED approval	The thermometer assembly can be provided with PED approval if required as the European Directive 2014/68/UE says. Calculation reports, testing procedures, certificates, are provided according the required calculation code and as foreseen in the product technical dossier.
Certification HART	The HART [®] temperature transmitter is registered by the FieldComm Group. The device meets the requirements of the HART [®] Communication Protocol Specifications.
Certification FOUNDATION Fieldbus	<p>The FOUNDATION Fieldbus[™] temperature transmitter has successfully passed all test procedures and is certified and registered by the Fieldbus Foundation. The device thus meets all the requirements of the following specification:</p> <ul style="list-style-type: none"> ■ Certified according to FOUNDATION Fieldbus[™] specification ■ FOUNDATION Fieldbus[™] H1 ■ Interoperability Test Kit (ITK), up to date revision status (device certification no. available on request): the device can also be operated with certified devices of other manufacturers ■ Physical layer conformance test of the FOUNDATION Fieldbus[™]
Certification PROFIBUS [®] PA	<p>The PROFIBUS[®] PA temperature transmitter is certified and registered by the PNO (PROFIBUS[®] Nutzerorganisation e. V.), PROFIBUS user organization. The device meets all the requirements of the following specifications:</p> <ul style="list-style-type: none"> ■ Certified according to FOUNDATION Fieldbus[™] specification ■ Certified in accordance with PROFIBUS[®] PA Profile (the up to date profile version is available on request) ■ The device can also be operated with certified devices of other manufacturers (interoperability)
Other standards and guidelines	<ul style="list-style-type: none"> ■ IEC 61326-1:2007: Electromagnetic compatibility (EMC requirements) ■ IEC 60529: Degree of protection of housing (IP code) ■ IEC 60584 and ASTM E230/ANSI MC96.1: Thermocouples ■ ASME B16.5, B16.36, EN 1092-1, GOST 12820-20: Flange
Material certification	The material certificate 3.1 (according to standard EN 10204) can be requested separately. The certificate includes a declaration related to the materials used in the construction of the single sensor and guarantees the traceability of the materials through the identification number of the multipoint. The data related to the origin of the materials can subsequently be requested by the client if necessary.

Test report and calibration The "Factory calibration" is carried out according to an internal procedure in a laboratory of Endress+Hauser accredited by the European Accreditation Organization (EA) to ISO/IEC 17025. A calibration which is performed according to EA guidelines (SIT/Accredia) or (DKD/DAkkS) may be requested separately. The calibration is performed on the inserts of the multipoint.

11.7 Documentation

This guide is referred to the complete assembly. To have a complete overview of the technical and operative instructions of the parts refer to the other documents of the individual components manufactured by Endress+Hauser:

- Technical Information iTEMP temperature transmitters:
 - HART® TMT82, two-channel, RTD, TC, Ω, mV (TI01010TEN_1715)
 - HART® TMT182, two-channel, RTD, TC, Ω, mV (TI078ren_1310)
 - TMT181, PC-programmable, single-channel, RTD, TC, Ω, mV (ti070ren)
 - PROFIBUS® PA TMT84, two-channel, RTD, TC, Ω, mV (TI00138ren_0412)
 - FOUNDATION Fieldbus™ TMT85, two-channel, RTD, TC, Ω, mV (TI00134REN_0313)
 - FOUNDATION Fieldbus™ TMT125, 8 channel, RTD, TC, Ω, mV (TI00131ren_0111)
- Technical Information of inserts:
 - Thermocouple thermometer iTHERM TSC310 (TI00255ten_0111)
- Technical Information of pressure transmitter:
 - CERABAR S PMP71 (TI00451PEN_0111)

www.addresses.endress.com
