

Technical Information

TH53, TH54 and TH55

Thermocouple assemblies in thermowells with spring loaded insert and enclosure for process industry



Application

The TH53, TH54 and TH55 temperature sensors are thermocouple assemblies installed in thermowells and designed for use in all types of process industries, including heavy industries, due to their rugged design. They are made up of a magnesium oxide insulated thermocouple as a measurement probe and a thermowell made of barstock material.

The sensor assemblies can be used in process industries such as:

- Chemicals
- Petrochemicals
- Power plants
- Refineries
- Offshore platforms

Head transmitter

All Endress+Hauser transmitters are available with enhanced accuracy and reliability compared to directly wired sensors. Instead of directly wiring your temperature sensors to your control system, use transmitters to reduce wiring and maintenance costs while increasing measurement accuracy.

Field transmitter

Temperature field transmitters with HART® or FOUNDATION Fieldbus™ protocol for highest reliability in harsh industrial environments. Backlit display with large measured value, bargraph and fault condition indication for ease of reading.

Your benefits

- One source shopping for temperature measurement solutions. World class transmitter with integrated sensor offering for heavy process industry applications.
- Remove and install straight out of the box!
- Improved galvanic isolation on most devices (2 kV).
- Simplified model structure: Competitively priced, offers great value. Easy to order and reorder. A single model number includes sensor, thermowell and transmitter assembly for a complete point solution.
- All iTEMP transmitters provide long-term stability $\leq 0.05\%$ per year.

Function and system design

Measuring principle

Thermocouples (TC)

Thermocouples are comparatively simple, robust temperature sensors which use the Seebeck effect for temperature measurement: if two electrical conductors made of different materials are connected at a point, a weak electrical voltage can be measured between the two open conductor ends if the conductors are subjected to a thermal gradient. This voltage is called thermoelectric voltage or electromotive force (emf.). Its magnitude depends on the type of conducting materials and the temperature difference between the "measuring point" (the junction of the two conductors) and the "cold junction" (the open conductor ends). Accordingly, thermocouples primarily only measure differences in temperature. The absolute temperature at the measuring point can be determined from these if the associated temperature at the cold junction is known or is measured separately and compensated for. The material combinations and associated thermoelectric voltage/temperature characteristics of the most common types of thermocouple are standardized in the IEC 60584 and ASTM E230/ANSI MC96.1 standards.

Measuring system

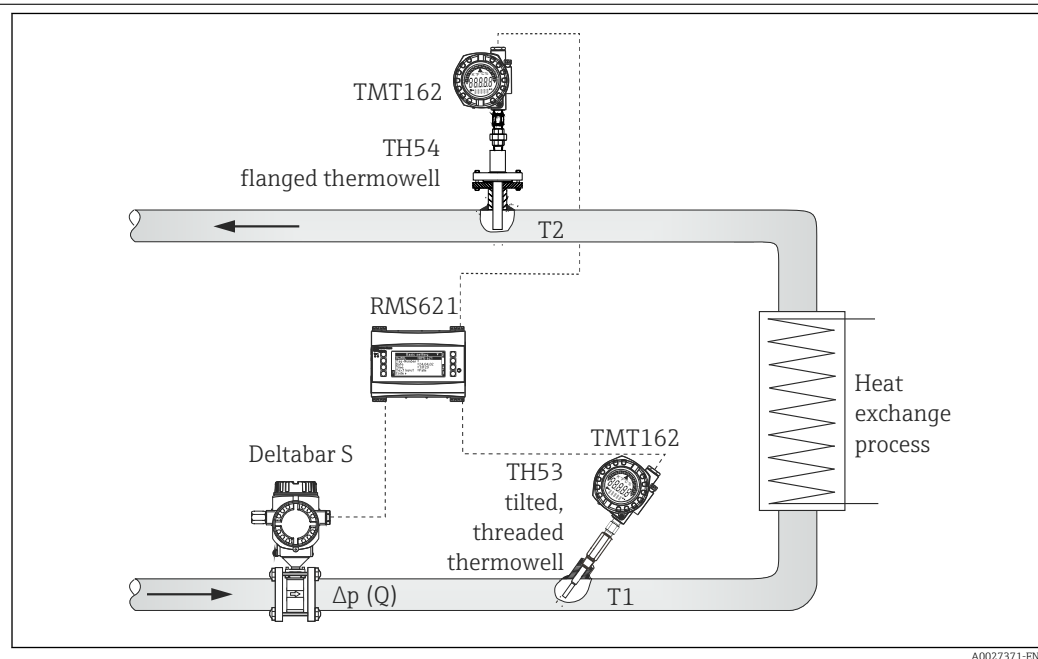

1 Application example

Calculation of heat quantity which is emitted or absorbed by a water flow in a heating or cooling system. The quantity of heat is calculated from the process variable for Δp flow (Q) and the differential from the feed and return temperature ($T_2 - T_1$). Bidirectional energy calculations, such as the calculating systems with changing flow direction (charging/ discharging the heat accumulator) are also possible.

Energy manager RMS621

Energy conservation and cost expenditures are significant issues in today's industry. Accurate flow monitoring and calculation is the basis for thorough analysis and billing of energy. This data can serve as a basis to maximize savings potential and help in controlling operational costs on a daily basis. Endress+Hauser's energy managers provide accurate and reliable calculations for the monitoring and control of energy consumption (both produced and consumed) according to international standards, e.g. IAPWS-IF 97, AGA8, ISO 5167 etc. For RMS621 details, see "Documentation".

iTEMP TMT162 Temperature Field Transmitter

Aluminum or stainless steel dual compartment explosion - proof enclosure and compact, fully potted electronics provide the ultimate protection in harshest environments. TMT162 prevents costly plant shutdowns by detecting corrosion on RTDs or thermocouples before it corrupts the measured value. Endress+Hauser's Field Temperature Transmitters with backlit display and sensor backup functionality are designed with safety in mind to keep your plant, equipment and personnel safe. More information on this can be found in the Technical Information, see "Documentation".

Deltabar S/Cerabar S

The evolution series of Cerabar S/Deltabar S represents a decisive step ahead in making pressure instrumentation better and safer for the process industry. The development of new products thrives especially on the knowledge, commitment and experience of staff members. Permanent high performance can only be achieved if dedicated and enthusiastic people provide their ideas. Endress+Hauser's instruments are not only supposed to distinguish themselves for customers and users by technological novelties but also by the presence of people supporting this progress, be it in service, sales or production. More information on this can be found in the Technical Information, see "Documentation".

Input

Measured variable Temperature (temperature-linear transmission behavior)

Measurement range

Upper Temperature limits for various thermocouple types in °C (°F)					
Sheath OD	Type T	Type J	Type E	Type K	Type N
ø¼"	370 °C (700 °F)	720 °C (1 330 °F)	820 °C (1 510 °F)	1 150 °C (2 100 °F)	
Maximum element temperature range limits	-270 to +400 °C (- 454 to +752 °F)	-210 to +1 200 °C (- 346 to +2 192 °F)	-270 to +1 000 °C (- 454 to +1 832 °F)	-270 to +1 372 °C (- 454 to +2 500 °F)	-270 to +1 300 °C (- 454 to +2 372 °F)

 These values are valid for single and duplex thermocouples. The temperature limits given are intended only as a guide to the user and should not be taken as absolute values or as guarantees of satisfactory life or performance. These types and sizes are sometimes used at temperatures above the given limits, but usually at the expense of stability or life or both. In other instances, it may be necessary to reduce the above limits in order to achieve adequate service.

Thermocouples with 316 SS sheath and assemblies with 316 SS thermowells are rated for a maximum temperature of 927 °C (1 700 °F).

Output

Output signal Generally, the measured value can be transmitted in one of two ways:

- Directly-wired sensors - sensor measured values forwarded without a transmitter.
- Via all common protocols by selecting an appropriate Endress+Hauser iTEMP temperature transmitter. All the transmitters listed below are mounted directly in the terminal head or as field transmitter and wired with the sensory mechanism.

Family of temperature transmitters

Thermometers fitted with iTEMP transmitters are an installation-ready complete solution to improve temperature measurement by significantly increasing accuracy and reliability, when compared to direct wired sensors, as well as reducing both wiring and maintenance costs.

PC programmable head transmitters

They offer a high degree of flexibility, thereby supporting universal application with low inventory storage. The iTEMP transmitters can be configured quickly and easily at a PC. Endress+Hauser offers free configuration software which can be downloaded from the Endress+Hauser Website. More information can be found in the Technical Information.

HART® programmable head transmitters

The transmitter is a 2-wire device with one or two measuring inputs and one analog output. The device not only transfers converted signals from resistance thermometers and thermocouples, it also transfers resistance and voltage signals using HART® communication. It can be installed as an intrinsically safe apparatus in Zone 1 hazardous areas and is used for instrumentation in the terminal head (flat face) as per DIN EN 50446. Swift and easy operation, visualization and

maintenance using universal device configuration tools like FieldCare, DeviceCare or FieldCommunicator 375/475. For more information, see the Technical Information.

PROFIBUS® PA head transmitters

Universally programmable head transmitter with PROFIBUS® PA communication. Conversion of various input signals into digital output signals. High accuracy over the complete ambient temperature range. The configuration of PROFIBUS PA functions and of device-specific parameters is performed via fieldbus communication. For more information, see the Technical Information.

FOUNDATION Fieldbus™ head transmitters

Universally programmable head transmitter with FOUNDATION Fieldbus™ communication. Conversion of various input signals into digital output signals. High accuracy over the complete ambient temperature range. All transmitters are released for use in all important process control systems. The integration tests are performed in Endress+Hauser's "System World". For more information, see the Technical Information.

Advantages of the iTEMP transmitters:

- Dual or single sensor input (optionally for certain transmitters)
- Pluggable display (optionally for certain transmitters)
- Unsurpassed reliability, accuracy and long-term stability in critical processes
- Mathematical functions
- Monitoring of the thermometer drift, sensor backup functionality, sensor diagnostic functions
- Sensor-transmitter matching for dual sensor input transmitters, based on Callendar/Van Dusen coefficients

Field transmitter

Field transmitter with HART® or FOUNDATION Fieldbus™ communication and backlit display. Can be read easily from a distance, in sunlight and at night. Large measurement value, bargraph and fault indication displayed. Benefits are: dual sensor input, highest reliability in harsh industrial environments, mathematic functions, thermometer drift monitoring and sensor back-up functionality, corrosion detection.

Galvanic isolation

Galvanic isolation of Endress+Hauser iTEMP transmitters

Transmitter type	Sensor
TMT181 PCP	$\hat{U} = 3.75 \text{ kV AC}$
TMT182 HART®	$U = 2 \text{ kV AC}$
TMT162 HART® Field transmitter	$U = 2 \text{ kV AC}$
TMT82 HART®	$U = 2 \text{ kV AC}$
TMT84 PA	
TMT85 FF	

 In applications where fast response time is needed, grounded thermocouples are recommended. This thermocouple design may cause a ground loop. This can be avoided by using iTEMP transmitters with high galvanic isolation.

Power supply

Terminal assignment

Type of sensor connection

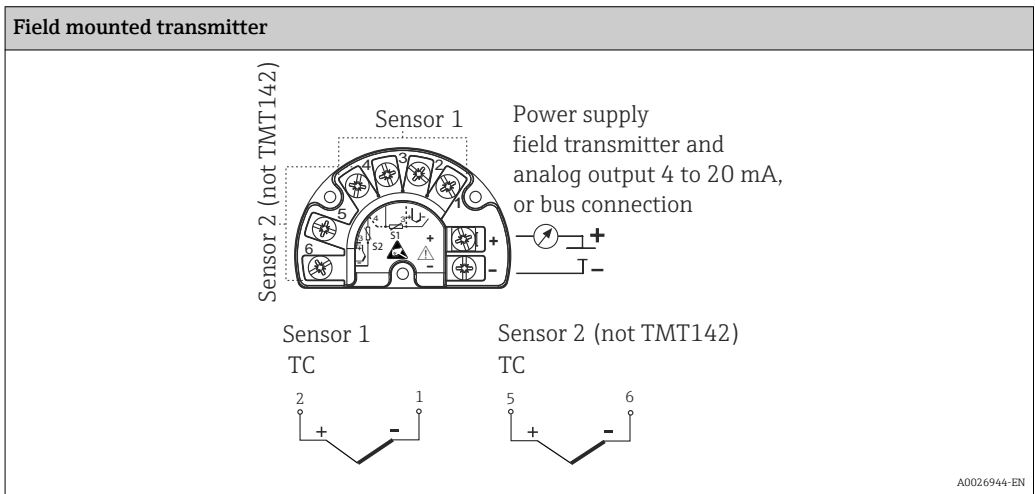
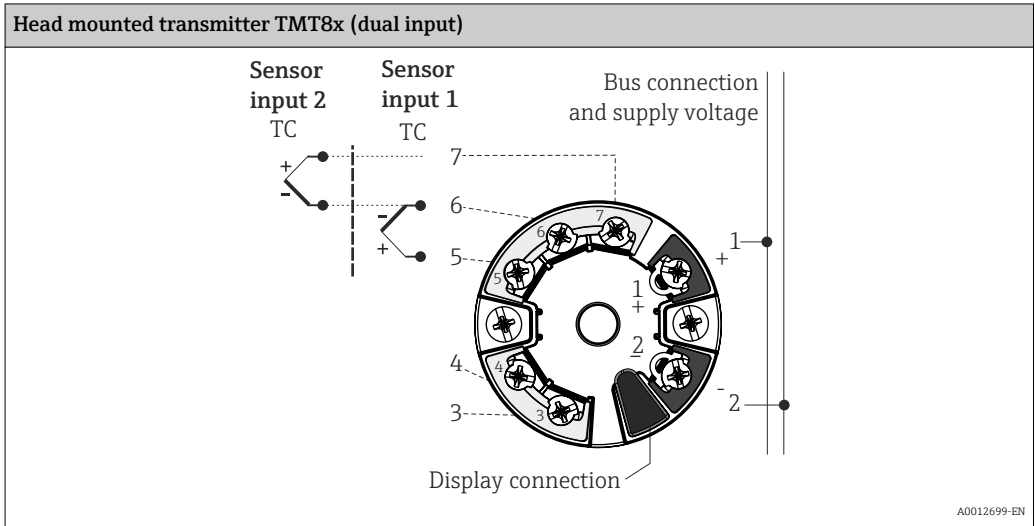
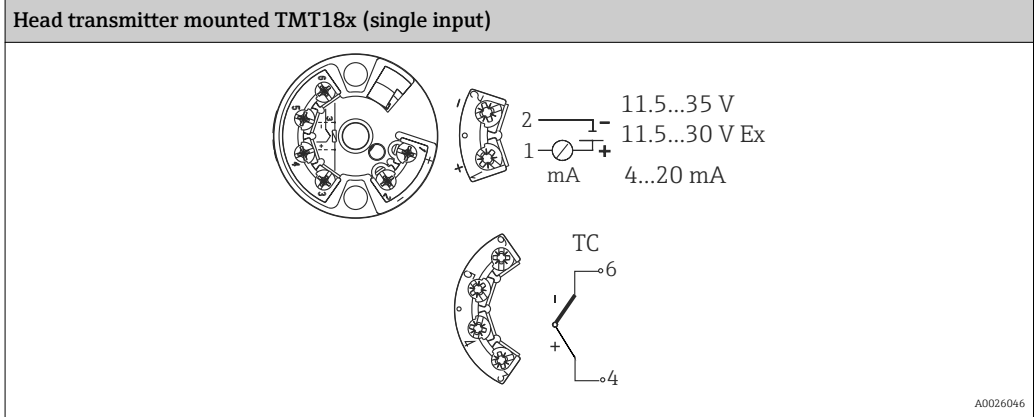

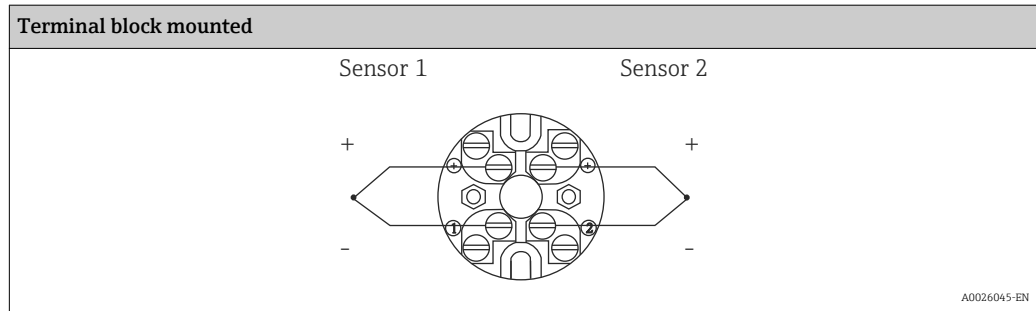

 The blocks and transmitters are shown as they sit inside the heads in reference to the conduit opening.

Integrated overvoltage protection

The integrated overvoltage protection module can be ordered as an optional extra ¹⁾. The module protects the electronics from damage from overvoltage. Overvoltage occurring in signal cables (e.g. 4 to 20 mA, communication lines (fieldbus systems) and power supply) is diverted to ground. The functionality of the transmitter is not affected as no problematic voltage drop occurs.

Connection data:

Maximum continuous voltage (rated voltage)	$U_C = 42 \text{ V}_{\text{DC}}$
Nominal current	$I = 0.5 \text{ A}$ at $T_{\text{amb.}} = 80 \text{ °C}$ (176 °F)
Surge current resistance <ul style="list-style-type: none"> ▪ Lightning surge current D1 (10/350 μs) ▪ Nominal discharge current C1/C2 (8/20 μs) 	<ul style="list-style-type: none"> ▪ $I_{\text{imp}} = 1 \text{ kA}$ (per wire) ▪ $I_n = 5 \text{ kA}$ (per wire) ▪ $I_n = 10 \text{ kA}$ (total)
Temperature range	-40 to $+80 \text{ °C}$ (-40 to $+176 \text{ °F}$)
Series resistance per wire	1.8Ω , tolerance $\pm 5 \%$

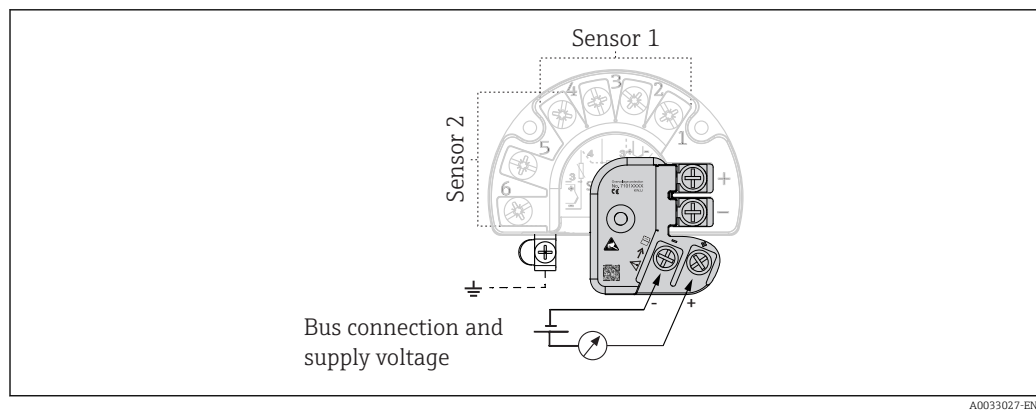

 2 Electrical connection of the overvoltage protection

Grounding

The device must be connected to the potential equalization. The connection between the housing and the local ground must have a minimum cross-section of 4 mm^2 (13 AWG). All ground connections must be secured tightly.

1) Available for the field transmitter with HART® 7 specification

Wire specifications

Thermocouple grade, TFE insulated 20AWG, 7 strands with stripped ends

Electrical connection
Flying leads, standard 139.7 mm (5.5 in) for wiring in connection head, head mounted transmitter or terminal block mounted, and for wiring with TMT162 or TMT142 assemblies

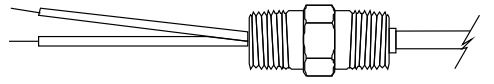
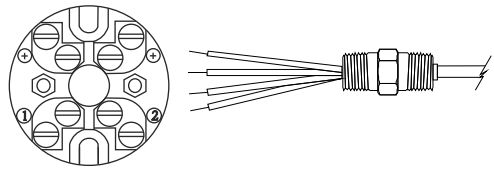
Design of leads	
Flying leads 139.7 mm (5.5 in) with stripped ends	 <p style="text-align: right; font-size: small;">A0027297</p>
Connection with terminal block (4 pole) with stripped ends	 <p style="text-align: right; font-size: small;">A0027298</p>

Thermocouple color codes according to ASTM E-230

T.C. Type	POS NEG	Material	MAGNETIC		Insulation	
			YES	NO	Single conductor	Overall T.C. wire
E	EP (+)	Nickel - 10% chromium		X	Purple	Brown
	EN (-)	Copper - 45% nickel (constantan)		X	Red	
J	JP (+)	Iron	X		White	Brown
	JN (-)	Copper - 45% nickel (constantan)		X	Red	
K	KP (+)	Nickel - 10% chromium		X	Yellow	Brown
	KN (-)	Nickel - 5% (aluminum, silicon) ¹⁾	X		Red	
T	TP (+)	Copper		X	Blue	Brown
	TN (-)	Copper - 45% nickel (constantan)		X	Red	
N	NP (+)	Nickel - 14% chromium - 1.5% silicon		X	Orange	Brown
	NN (-)	Nickel - 4.5% silicon - 0.1% magnesium		X	Red	

1) Silicon, or aluminum and silicon may be present in combination with other elements.

Performance characteristics

Reference conditions

These data are relevant for determining the accuracy of the temperature transmitters used. More information on this can be found in the Technical Information of the iTEMP temperature transmitters.

Response time

63% response time per ASTM E839

Thermocouple assembly TH55 without thermowell

Junction style	Thermocouple insert $\varnothing\frac{1}{4}$ "
Grounded	1.3 s
Ungrounded	2.9 s

 Response time for the sensor assembly without transmitter.

Response time examples for thermocouples assemblies with thermowell TH53 and TH54

Construction	Stepped thermowell	Tapered thermowell	3/4" straight thermowell
Time	15 s	20 s	25 s

 Response times for thermocouple assemblies with thermowell are provided for general design guidance without transmitter.

When the temperature of a process media changes, the output signal of a Thermocouple assembly follows this change after a certain time delay. The physical cause is the time related to heat transfer from the process media through the thermowell and the insert to the sensor element (thermocouple). The manner in which the reading follows the change in temperature of the assembly over time is referred to as the response time. Variables that influence or impact the response time are:

- Wall thickness of thermowell
- Spacing between thermocouple insert and thermowell
- Sensor packing
- Process parameters such as media, flow velocity, etc.

Maximum measured error

Thermocouples corresponding to ASTM E839

Type	Temperature range	Standard tolerance (IEC class 2)	Special tolerance (IEC class 1)
		[°C] whichever is greater	[°C] whichever is greater
E	0 to 870 °C (32 to 1600 °F)	±1.7 or ±0.5%	±1 or ±0.4%
J	0 to 760 °C (32 to 1400 °F)	±2.2 or ±0.75%	±1.1 or ±0.4%
K	0 to 1260 °C (32 to 2300 °F)	±2.2 or ±0.75%	±1.1 or ±0.4%
T	0 to 370 °C (32 to 700 °F)	±1 or 0.75%	±0.5 or ±0.4%
N	0 to 1260 °C (32 to 2300 °F)	±2.2 or ±0.75%	±1.1 or ±0.4%

 For measurement errors in °F, calculate using equation above in °C, then multiply the outcome by 1.8.

Transmitter long-term stability

≤ 0.1 °C (0.18 °F) / year or ≤ 0.05 % / year

Data under reference conditions; % relates to the set span. The larger value applies.

Insulation resistance

Insulation resistance for MgO insulated thermocouples with ungrounded hot junction between terminals and probe sheath, test voltage 500 V_{DC}.

1000 MΩ at 25 °C (77 °F)

These values for insulation resistance also apply between each thermocouple wire at single and duplex constructions with ungrounded hot junction.

Calibration specifications

The manufacturer provides an option to provide comparison temperature calibrations from -20 to 300 °C (-4 to 572 °F)²⁾ on the International Temperature Scale of 1990. Calibrations are traceable to standards maintained by the National Institute of Standards and Technology (NIST). Calibration services are in conformance with ASTM E220, IEC 17025 and ANSI/NCSL Z540-1-1994. The report of calibration is referenced to the serial number of the assembly.

Three point calibrations are provided, given that the specified temperatures are within the recommended range and the minimum length requirements are met as specified. The minimum length is based on the overall length "x" of the spring loaded insert.

2) Other ranges may be available on request.

Installation conditions

Orientation No restrictions.

Installation instructions

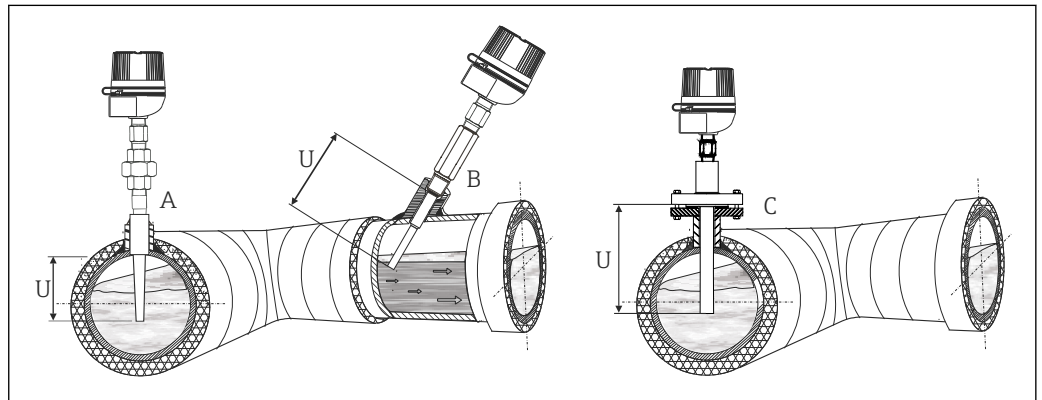

3 Installation examples

A-C In pipes with a small cross section the thermowell tip should reach or extend slightly past the center line of the pipe (= U)

B Threaded, angled installation of TH53 assembly

C Flange installation of TH54 assembly

The immersion length of the thermometer influences the accuracy. If the immersion length is too small then errors in the measurement are caused by heat conduction via the process connection and the container wall. If installing into a pipe then the immersion length should be at least half of the pipe diameter. A further solution could be an angled (tilted) installation (see B). When determining the immersion length all thermometer parameters and the process to be measured must be taken into account (e.g. flow velocity, process pressure).

- Installation possibilities: Pipes, tanks or other plant components
- Minimum immersion length per ASTM E644, $\Delta T \leq 0.05 \text{ }^\circ\text{C}$ (0.09 $^\circ\text{F}$):

For temperature assemblies with thermowell (TH53 and TH54) the minimum immersion is the depth to which the thermowell is immersed in the medium, measured from the tip. To minimize errors from ambient temperature the following minimum immersion lengths are recommended:

Construction	Minimum immersion
Stepped thermowell	63.5 mm (2.5 in)
Tapered thermowell	114.3 mm (4.5 in)
¾" straight thermowell	101.6 mm (4 in)
Weld-in thermowell	114.3 mm (4.5 in)

 TH55 assemblies can only be used in existing thermowells.

Environment

Ambient temperature range

Terminal head	Temperature in $^\circ\text{C}$ ($^\circ\text{F}$)
Without mounted head transmitter	Depends on the terminal head used and the cable gland or fieldbus connector, see 'Terminal heads' section
With mounted head transmitter	-40 to 85 $^\circ\text{C}$ (-40 to 185 $^\circ\text{F}$) SIL mode (HART 7 transmitter): -40 to 70 $^\circ\text{C}$ (-40 to 158 $^\circ\text{F}$)

Terminal head	Temperature in °C (°F)
With mounted head transmitter and display	-20 to 70 °C (-4 to 158 °F)
With mounted field transmitter	<ul style="list-style-type: none">▪ Without display: -40 to 85 °C (-40 to 185 °F)▪ With display and/or integrated overvoltage protection module: -40 to +80 °C (-40 to +176 °F)▪ SIL mode: -40 to +75 °C (-40 to +167 °F)

Shock and vibration resistance

4 g/2 to 150 Hz as per IEC 60068-2-6

Mechanical construction

Design, dimensions

All dimensions in inch. For values related to the graphics please refer to the tables and equations below.

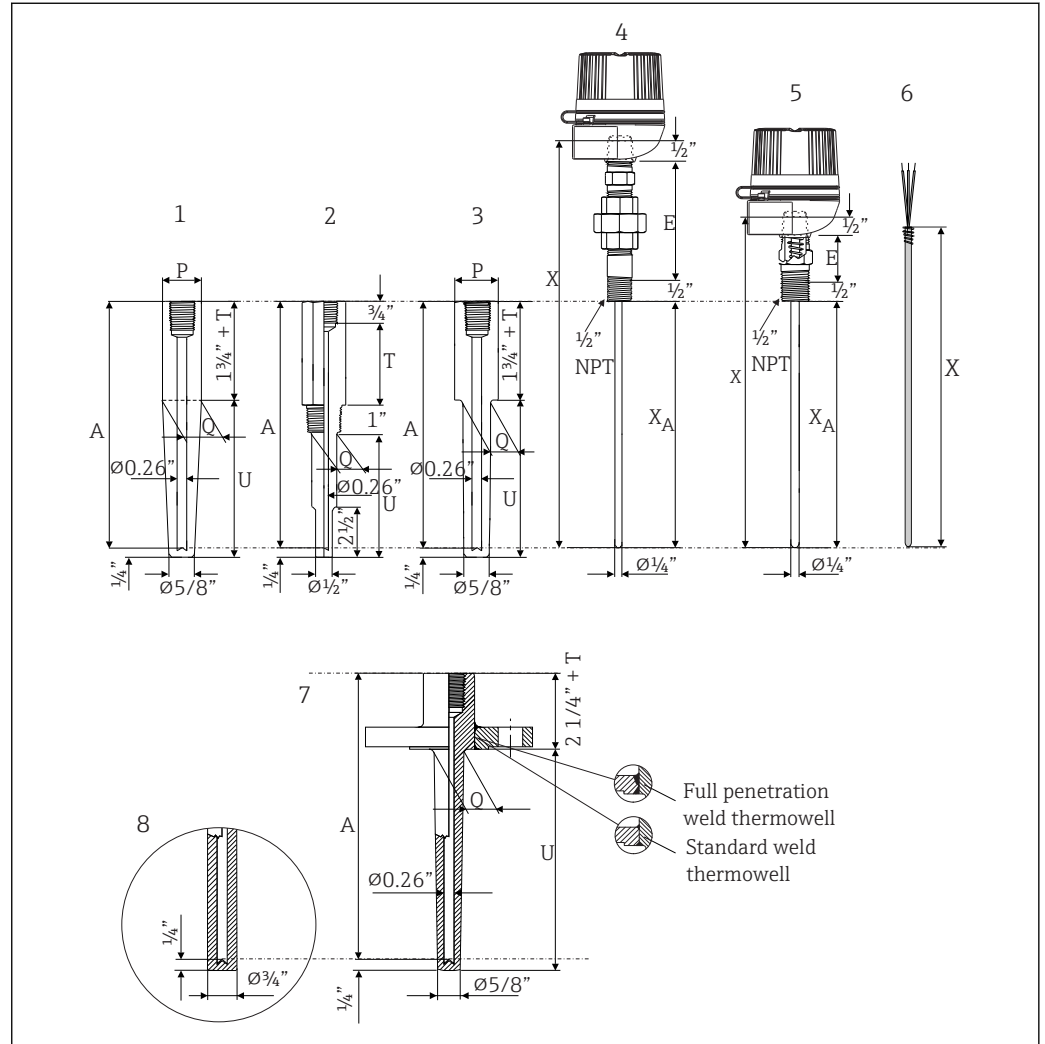

A0027685-EN

4 Dimensions of the sensor assemblies

- 1 TH53 weld-in thermowell (tapered)
 - 2 TH53 threaded thermowell (stepped)
 - 3 TH53 socket weld thermowell (tapered)
 - 4 TH53/TH54 extension, nipple-union-nipple (NUN), without thermowell
 - 5 TH55 extension hex nipple without thermowell
 - 6 TU121 spring loaded insert
 - 7 TH54 flange thermowell (tapered)
 - 8 Straight thermowell tip
- E Extension length
 P Pipe size
 Q Thermowell root diameter
 T Lag dimension
 U Thermowell immersion length
 XA Immersion length thermocouple sensor
 A Drill depth of thermowell
 X Overall insert length

i For TH53 thermowells with 1/2" NPT and 1" process thread length and 3/4" hex length dimensions, spring loaded sensor assemblies must be used with the thermowells.

All thermowells are marked with a material ID, CRN (Canadian Registration Number) and heat number.

Dimensions of TH53

U	E (nominal dimension)	T	Process connection	Shape of thermowell	ØQ		
63.5 mm (2.5 in)	Material: Steel or 316 Hex nipple = 25.4 mm (1 in) Nipple Union Nipple (NUN) = 101.6 mm (4 in) 177.8 mm (7 in)	76.2 mm (3 in) or specified length 25.4 to 152.4 mm (1 to 6 in) in ½" increments	½" NPT	Stepped (standard duty)	16 mm (⅝ in)		
114.3 mm (4.5 in)				Tapered (heavy duty)	16 mm (⅝ in)		
			190.5 mm (7.5 in)	¾" NPT	Stepped (standard duty)	19.05 mm (¾ in)	
Tapered (heavy duty)					22.3 mm (⅞ in)		
266.7 mm (10.5 in)			1" NPT	Stepped (standard duty)	22.3 mm (⅞ in)		
				Tapered (heavy duty)	26.9 mm (1⅛ in)		
342.9 mm (13.5 in)			¾" socket weld	Stepped (standard duty)	19.05 mm (¾ in)		
				Tapered (heavy duty)	22.3 mm (⅞ in)		
419.1 mm (16.5 in)			1" socket weld	Stepped (standard duty)	22.3 mm (⅞ in)		
				Tapered (heavy duty)	25.4 mm (1 in)		
571.5 mm (22.5 in) specified length			¾" weld in	Tapered (heavy duty)	26.6 mm (1.050 in)		
				1" weld in	33.4 mm (1.315 in)		
50.8 to 609.6 mm (2 to 24 in) in ½" increments							
Immersion length thermocouple sensor = thermowell drilled length			$X_A = A = U + 38.1 \text{ mm (1.5 in) } + T$				
Overall insert length			$X = A + E$				
P = Pipe size							
<ul style="list-style-type: none"> ■ ¾" Nominal utilizes 1.050" ■ 1" Nominal utilizes 1.315" 							

Dimensions of TH54

U	E (nominal dimension)	T	Flange size	ØQ, tapered version
50.8 mm (2 in)	Hex nipple = 25.4 mm (1 in) or	specified length 25.4 to 254 mm (1 to 10 in) in ½" increments	25.4 mm (1 in)	22.3 mm (⅞ in)
101.6 mm (4 in)	Nipple Union Nipple (NUN) = 101.6 mm (4 in) 177.8 mm (7 in)		38.1 mm (1½ in)	26.9 mm (1⅛ in)
177.8 mm (7 in)			50.8 mm (2 in)	26.9 mm (1⅛ in)
254 mm (10 in)			76.2 mm (3 in)	
330.2 mm (13 in)				
406.4 mm (16 in)				
558.8 mm (22 in)				
specified length 50.8 to 609.6 mm (2 to 24 in) in ½" increments				

U	E (nominal dimension)	T	Flange size	ØQ, tapered version
Immersion length thermocouple sensor = thermowell drilled length		$X = A = U + 50.8 \text{ mm (2 in)} + T$		
Overall insert length		$X = A + E$		

Dimensions of TH55 (without thermowell)		Extension E
Immersion length	Thermocouple sensor X_A	Hex nipple = 25.4 mm (1 in) or Nipple Union Nipple (NUN) = 101.6 mm (4 in) 177.8 mm (7 in)
	101.6 mm (4 in) 152.4 mm (6 in) 228.6 mm (9 in) 304.8 mm (12 in) 355.6 mm (14 in) specified length 101.6 to 762 mm (4 to 30 in) in ½" increments	

Hot or measuring junction

Grounded junction

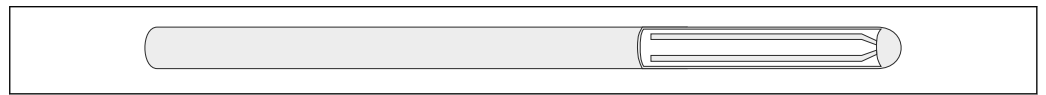

A0026086

5 Grounded junction

The thermocouple junction is welded securely into the closure end of the sheath, becoming an integral part of the weld. This is a good general purpose, low cost junction providing faster response times than an ungrounded junction of similar sheath diameter. Grounded junctions should not be used with Type T thermocouples, due to the copper wire. For a reliable temperature reading of grounded thermocouples transmitters with galvanic isolation are strongly recommended. iTEMP transmitters have galvanic isolation of min. 2 kV (from the sensor input to the output and the housing).

Ungrounded junction

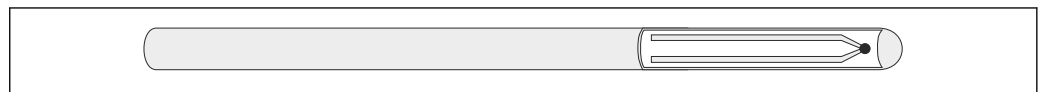

A0026087

6 Ungrounded junction

The welded thermocouple junction is fully isolated from the welded closed end sheath. This junction provides electrical isolation to reduce problems associated with electrical interference. Ungrounded junctions are also recommended for use in extreme positive or negative temperatures, rapid thermal cycling and for ultimate corrosion resistance of the sheath alloy. iTEMP transmitters have an excellent noise immunity (EMC) meeting all requirements listed under IEC 61326 for use in noisy environments.

Weight

1 to 30 lbs

Material

Process connection and thermowell

The temperatures for continuous operation specified in the following table are only intended as reference values for use of the various materials in air and without any significant compressive load. The maximum operation temperatures are reduced considerably in some cases where abnormal conditions such as high mechanical load occur or in aggressive media.

Material name	Short form	Recommended max. temperature for continuous use in air	Properties
AISI 316/ 1.4401	X5CrNiMo17-12-2	650 °C (1 202 °F) ¹⁾	<ul style="list-style-type: none"> ▪ Austenitic, stainless steel ▪ High corrosion resistance in general ▪ Particularly high corrosion resistance in chlorine-based and acidic, non-oxidizing atmospheres through the addition of molybdenum (e.g. phosphoric and sulfuric acids, acetic and tartaric acids with a low concentration)
AISI 316L/ 1.4404 1.4435	X2CrNiMo17-12-2 X2CrNiMo18-14-3	650 °C (1 202 °F) ¹⁾	<ul style="list-style-type: none"> ▪ Austenitic, stainless steel ▪ High corrosion resistance in general ▪ Particularly high corrosion resistance in chlorine-based and acidic, non-oxidizing atmospheres through the addition of molybdenum (e.g. phosphoric and sulfuric acids, acetic and tartaric acids with a low concentration) ▪ Increased resistance to intergranular corrosion and pitting ▪ Compared to 1.4404, 1.4435 has even higher corrosion resistance and a lower delta ferrite content
Alloy600	NiCr15Fe	1 100 °C (2 012 °F)	<ul style="list-style-type: none"> ▪ A nickel/chromium alloy with very good resistance to aggressive, oxidizing and reducing atmospheres, even at high temperatures ▪ Resistant to corrosion caused by chlorine gas and chlorinated media as well as many oxidizing mineral and organic acids, sea water etc. ▪ Corrosion from ultrapure water ▪ Not to be used in a sulfur-containing atmosphere

1) Can be used to a limited extent up to 800 °C (1472 °F) for low compressive loads and in non-corrosive media. Please contact your Endress+Hauser sales team for further information.

Process connection

The process connection is the means of connecting the thermometer to the process. The following process connections are available:

TH53

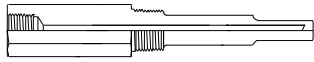
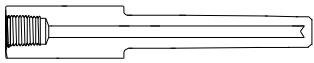
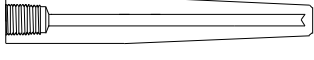
Thread	Version
 A0026110	NPT thread
	NPT 1/2"
	NPT 3/4"
 A0026111	NPS for socket weld
	NPS 3/4"
 A0026108	NPS for weld-in
	NPS 1"

TH54

Flange	
<small>A0010471</small>	
<p>For detailed information on the flange dimensions refer to the following flange standard: ANSI/ASME B16.5</p>	<p>The flange material must be the same as of the stem of the thermowell.</p>

TH55

Type	Thermowell connection	Extension neck lengths in mm (in)
<p>Type N Type NUN</p>	Type N	½" NPT external thread 25.4 mm (1 in)
	Type NUN	½" NPT external thread 101.6 mm (4 in) 177.8 mm (7 in)
<small>A0026181</small>		

Housing

Terminal heads

All terminal heads have an internal shape and size in accordance with DIN EN 50446, flat face and a thermometer connection with a ½" NPT thread. All dimensions in mm (in). Specifications without head transmitter installed. For ambient temperatures with head transmitter installed, see the 'Environment' section.

As a special feature, Endress+Hauser offers terminal heads with optimized terminal accessibility for easy installation and maintenance.

Some of the specifications listed below may not be available on this product line.

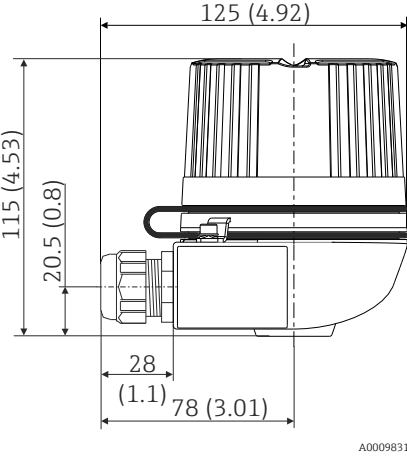
TA30H with display window in cover	Specification
 <p>A0009831</p>	<ul style="list-style-type: none"> ▪ Flameproof (XP) version, explosion-protected, captive screw cap, available with one or two cable entries ▪ Degree of protection: IP 66/68, NEMA Type 4x Encl. Ex-version: IP 66/67 ▪ Temperature: -50 to +150 °C (-58 to +302 °F) for rubber seal without cable gland (observe max. permitted temperature of cable gland!) ▪ Material: <ul style="list-style-type: none"> - Aluminum with polyester powder coating - Stainless steel 316L without coating ▪ Thread: ½" NPT, ¾" NPT, M20x1.5, G½" ▪ Extension neck/thermowell connection: ½" NPT ▪ Color of aluminum head: blue, RAL 5012 ▪ Color of aluminum cap: gray, RAL 7035 ▪ Weight: <ul style="list-style-type: none"> - Aluminum: approx. 860 g (30.33 oz) - Stainless steel: approx. 2 900 g (102.3 oz) ▪ Head transmitter optionally available with TID10 display

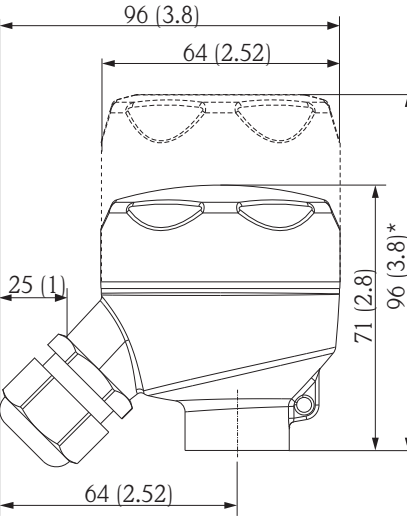
TA30R (optionally with display window in cover)	Specification
 <p>A0017145</p>	<ul style="list-style-type: none"> ▪ Degree of protection - standard version: IP69K (NEMA Type 4x encl.) Degree of protection - version with display window: IP66/68 (NEMA Type 4x encl.) ▪ Temperature: -50 to +130 °C (-58 to +266 °F) without cable gland ▪ Material: stainless steel 316L, abrasive-blasted or polished Seals: EPDM Display window: polycarbonate (PC) ▪ Cable entry thread ½" NPT and M20x1.5 ▪ Weight <ul style="list-style-type: none"> - Standard version: 360 g (12.7 oz) - Version with display window: 460 g (16.23 oz) ▪ Display window in cover optionally for head transmitter with display TID10 ▪ Protection armature connection: M24x1.5 or ½" NPT ▪ Ground terminal: internal in standard version; external terminal optionally available ▪ Available in conjunction with 3-A marked sensors
<p>* Dimensions of version with display window in cover</p>	

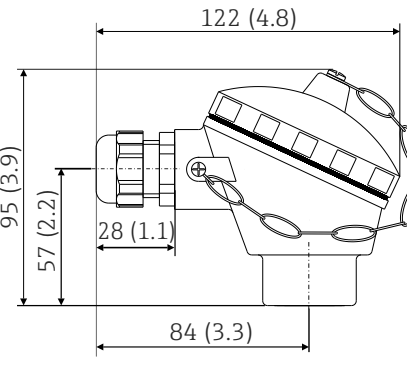
TU401	Specification
 <p>A0008669</p>	<ul style="list-style-type: none"> ▪ Protection class: IP65 (NEMA Type 4x encl.) ▪ Temperature: -40 to 130 °C (-40 to 266 °F) silicone, up to 100 °C (212 °F) rubber seal without cable gland (observe max. permitted temperature of the cable gland!) ▪ Material: aluminum alloy with polyester or epoxy coating, rubber or silicone seal under the cover ▪ Cable entry: M20x1.5 or plug M12x1 PA ▪ Protection armature connection: M24x1.5, G 1/2" or NPT 1/2" ▪ Head color: blue, RAL 5012 ▪ Cap color: gray, RAL 7035 ▪ Weight: 300 g (10.58 oz)

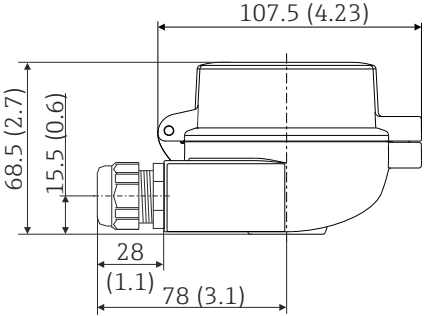
TU401 (TA30A style)	Specification
 <p style="text-align: right; font-size: small;">A0009820</p>	<ul style="list-style-type: none"> ▪ Available with one or two cable entries ▪ Protection class: IP66/68 (NEMA Type 4x incl.) ▪ Temperature: -50 to +150 °C (-58 to +302 °F) without cable gland ▪ Material: aluminum, polyester powder coated ▪ Seals: silicone ▪ Threaded cable entry: ½" NPT, ¾" NPT or plug 7/8" FF ▪ Protection armature connection: M24x1.5 ▪ Head color: blue, RAL 5012 ▪ Cap color: gray, RAL 7035 ▪ Weight: 330 g (11.64 oz) ▪ Ground terminal, internal and external ▪ With 3-A symbol

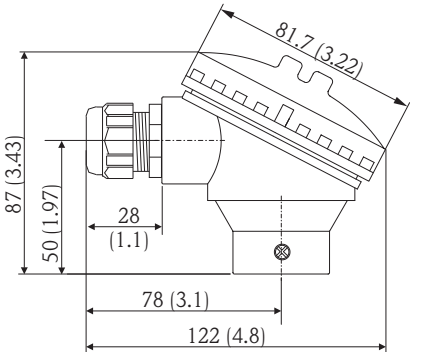
TU401 (TA30S style)	Specification
 <p style="text-align: right; font-size: small;">A0017146</p>	<ul style="list-style-type: none"> ▪ Degree of protection: IP65 (NEMA Type 4x incl.) ▪ Temperature: -40 to +85 °C (-40 to +185 °F) without cable gland ▪ Material: polypropylene (PP), FDA-compliant, seals: O-ring EPDM ▪ Cable entry thread: ¾" NPT (with adapter for ½" NPT), M20x1.5 ▪ Protective assembly connection: ½" NPT ▪ Color: white ▪ Weight: approx. 100 g (3.5 oz) ▪ Ground terminal: only internal via auxiliary terminal <p style="background-color: yellow; display: inline-block; padding: 2px;">CAUTION</p> <p>Potential electrostatic charging hazard</p> <ul style="list-style-type: none"> ▶ Not recommended for use in hazardous (classified) locations.

Field transmitters

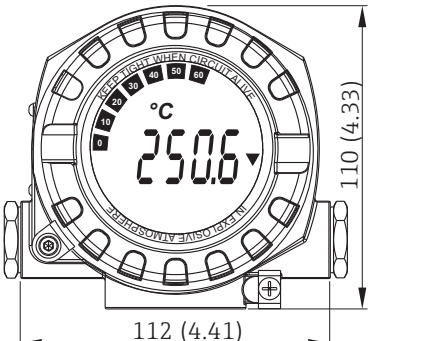
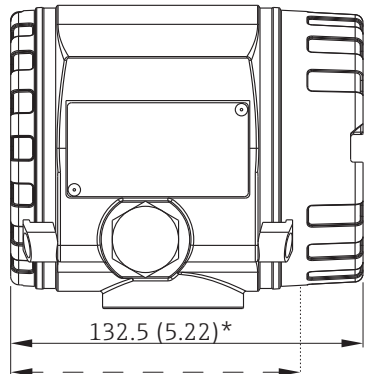
Temperature field transmitter iTEMP TMT162	
	 <p style="text-align: right; font-size: small;">A0024608</p>
<p>* Dimensions without display = 112 mm (4.41 in)</p>	
<ul style="list-style-type: none"> ▪ Separate electronics compartment and connection compartment ▪ Protection class: IP67, NEMA type 4x ▪ Material: Die-cast aluminum housing AlSi10Mg with powder coating on polyester base, 316L ▪ Display rotatable in 90° increments ▪ Cable entry: 2x ½" NPT ▪ Brilliant backlit display with ease of visibility in bright sunshine or pitch darkness ▪ Gold plated terminals to avoid corrosion and additional measurement errors ▪ SIL certification as per IEC 61508:2010 (HART-protocol) 	

Temperature field transmitter iTEMP HART® TMT142

Technical drawing showing front and side views of the transmitter. Dimensions are provided in mm (inches):

- Front view dimensions: 132 (5.2) mm width, 135 (5.3) mm height, 121 (4.8) mm inner height, 112 (4.4) mm inner width, 121 (4.8) mm bottom width, and a diameter of 66.4 (2.61) mm for the display area.
- Side view dimension: 106 (4.2) mm depth.

Specifications:

- Protection class: IP67, NEMA type 4x
- Material: Die-cast aluminum housing AlSi10Mg with powder coating on polyester base
- Display rotatable in 90° increments
- Cable entry: 3x 1/2" NPT
- Brilliant blue backlit display with ease of visibility in bright sunshine or pitch darkness
- Gold plated terminals to avoid corrosion and additional measurement errors

A0025824

Fieldbus connector

Type, dimensions in mm (in)	Specification		
<p>Fieldbus connector to PROFIBUS PA or FOUNDATION Fieldbus™</p> <p>Pos. A: M12 on PROFIBUS PA connector 7/8-16 UNC on FOUNDATION Fieldbus™ connector</p> <p>A0027381</p>	<ul style="list-style-type: none"> Ambient temperature: -40 to 150 °C (-40 to 300 °F) Degree of protection: IP67 <p>Wiring diagram:</p> <p>A0006023</p> <table border="1"> <tr> <td> <p>PROFIBUS PA</p> <p>Pos 1: gray (shield)</p> <p>Pos 2: brown (+)</p> <p>Pos 3: blue (-)</p> <p>Pos 4: not connected</p> </td> <td> <p>FOUNDATION Fieldbus™</p> <p>Pos 1: blue (-)</p> <p>Pos 2: brown (+)</p> <p>Pos 3: not connected</p> <p>Pos 4: ground (green/yellow)</p> </td> </tr> </table>	<p>PROFIBUS PA</p> <p>Pos 1: gray (shield)</p> <p>Pos 2: brown (+)</p> <p>Pos 3: blue (-)</p> <p>Pos 4: not connected</p>	<p>FOUNDATION Fieldbus™</p> <p>Pos 1: blue (-)</p> <p>Pos 2: brown (+)</p> <p>Pos 3: not connected</p> <p>Pos 4: ground (green/yellow)</p>
<p>PROFIBUS PA</p> <p>Pos 1: gray (shield)</p> <p>Pos 2: brown (+)</p> <p>Pos 3: blue (-)</p> <p>Pos 4: not connected</p>	<p>FOUNDATION Fieldbus™</p> <p>Pos 1: blue (-)</p> <p>Pos 2: brown (+)</p> <p>Pos 3: not connected</p> <p>Pos 4: ground (green/yellow)</p>		

Certificates and approvals

CE Mark

The device meets the legal requirements of the EC directives if applicable. Endress+Hauser confirms that the device has been successfully tested by applying the CE mark.

Other standards and guidelines

- IEC 60529: Degree of protection of housing (IP code)
- IEC 61010-1: Safety requirements for electrical equipment for measurement, control, and laboratory use – Part 1: General requirements
- IEC 60584 and ASTM E230/ANSI MC96.1: Thermocouples
- ASTM E-230: Standard Specification and Temperature-Electromotive Force (EMF) Tables for Standardized Thermocouples

- ASTM E839: American society for testing and materials, standard test methods for sheathed thermocouples and sheathed thermocouple material
- NEMA - ANSI/NEMA 250: Enclosures for Electrical Equipment
- ASME PTC 19.3 TW2010: Performance test codes

UL Temperature transmitters UL recognized components under Category Code.file number QUYX8.E225237 and QUYX2.E225237

CSA GP The installed and assembled temperature transmitters (iTEMP series) are CSA GP approved.

Ordering information

Detailed ordering information is available from the following sources:

- In the Product Configurator on the Endress+Hauser website: www.endress.com -> Click "Corporate" -> Select your country -> Click "Products" -> Select the product using the filters and search field -> Open product page -> The "Configure" button to the right of the product image opens the Product Configurator.
- From your Endress+Hauser Sales Center: www.addresses.endress.com



Product Configurator - the tool for individual product configuration

- Up-to-the-minute configuration data
- Depending on the device: Direct input of measuring point-specific information such as measuring range or operating language
- Automatic verification of exclusion criteria
- Automatic creation of the order code and its breakdown in PDF or Excel output format
- Ability to order directly in the Endress+Hauser Online Shop





Accessories

Various accessories, which can be ordered with the device or subsequently from Endress+Hauser, are available for the device. Detailed information on the order code in question is available from your local Endress+Hauser sales center or on the product page of the Endress+Hauser website: www.endress.com.

Device-specific accessories

Adapter	M20x1.5 - ½" NPT cable entry Order code: 51004387
Cable gland	½" NPT, D4.5-8.5, IP 68 Order code: 51006845
Integrated overvoltage protection module	The module protects the electronics from overvoltage. Available for TMT162 housing (not T17 hygienic version).

Communication-specific accessories

Configuration kit TXU10	Configuration kit for PC-programmable transmitter with setup software and interface cable for PC with USB port Order code: TXU10-xx
Commubox FXA195 HART	For intrinsically safe HART communication with FieldCare via the USB interface.  For details, see "Technical Information" TI00404F
Commubox FXA291	Connects Endress+Hauser field devices with a CDI interface (= Endress+Hauser Common Data Interface) and the USB port of a computer or laptop.  For details, see "Technical Information" TI00405C
Wireless HART adapter SWA70	Is used for the wireless connection of field devices. The WirelessHART adapter can be easily integrated into field devices and existing infrastructures, offers data protection and transmission safety and can be operated in parallel with other wireless networks with minimum cabling complexity.  For details, see Operating Instructions BA061S
Field Xpert SFX350	Field Xpert SFX350 is a mobile computer for commissioning and maintenance. It enables efficient device configuration and diagnostics for HART and FOUNDATION Fieldbus devices in the non-Ex area .  For details, see Operating Instructions BA01202S
Field Xpert SFX370	Field Xpert SFX370 is a mobile computer for commissioning and maintenance. It enables efficient device configuration and diagnostics for HART and FOUNDATION Fieldbus devices in the non-Ex area and the Ex area .  For details, see Operating Instructions BA01202S

Service-specific accessories

Accessories	Description
Applicator	Software for selecting and sizing Endress+Hauser measuring devices: <ul style="list-style-type: none"> Calculation of all the necessary data for identifying the optimum measuring device: e.g. pressure loss, accuracy or process connections. Graphic illustration of the calculation results Administration, documentation and access to all project-related data and parameters over the entire life cycle of a project. Applicator is available: <ul style="list-style-type: none"> Via the Internet: https://portal.endress.com/webapp/applicator On CD-ROM for local PC installation.



Configurator	<p>Product Configurator - the tool for individual product configuration</p> <ul style="list-style-type: none"> ▪ Up-to-the-minute configuration data ▪ Depending on the device: Direct input of measuring point-specific information such as measuring range or operating language ▪ Automatic verification of exclusion criteria ▪ Automatic creation of the order code and its breakdown in PDF or Excel output format ▪ Ability to order directly in the Endress+Hauser Online Shop <p>The Configurator is available on the Endress+Hauser website: www.endress.com -> Click "Corporate" -> Select your country -> Click "Products" -> Select the product using the filters and the search field -> Open the product page -> The "Configure" button to the right of the product image opens the Product Configurator.</p>
--------------	--

W@M	<p>Life cycle management for your plant</p> <p>W@M supports you with a wide range of software applications over the entire process: from planning and procurement, to the installation, commissioning and operation of the measuring devices. All the relevant device information, such as the device status, spare parts and device-specific documentation, is available for every device over the entire life cycle.</p> <p>The application already contains the data of your Endress+Hauser device. Endress+Hauser also takes care of maintaining and updating the data records.</p> <p>W@M is available:</p> <ul style="list-style-type: none"> ▪ Via the Internet: www.endress.com/lifecyclemanagement ▪ On CD-ROM for local PC installation.
-----	---

FieldCare SFE500	<p>FDT-based plant asset management tool from Endress+Hauser. It can configure all smart field units in your system and helps you manage them. By using the status information, it is also a simple but effective way of checking their status and condition.</p> <p> For details, see Operating Instructions BA00027S and BA00065S</p>
------------------	--

DeviceCare SFE100	<p>Configuration tool for devices via fieldbus protocols and Endress+Hauser service protocols.</p> <p>DeviceCare is the tool developed by Endress+Hauser for the configuration of Endress+Hauser devices. All smart devices in a plant can be configured via a point-to-point or point-to-bus connection. The user-friendly menus enable transparent and intuitive access to the field devices.</p> <p> For details, see Operating Instructions BA00027S</p>
-------------------	---

System components

Accessories	Description
Energy manager RMS621	<p>Accurate and reliable calculations for the monitoring and control of energy consumption (both produced and consumed) according to international standards.</p> <p> For details, see the "Technical Information" document TI00092R/09/EN</p>
Deltabar S/Cerabar S	<p>Pressure transmitters with diaphragm seal for level measurements in gases or liquids.</p> <p> For details, see "Technical Information"</p>
Process display RIA15	<p>Process display, digital loop-powered display for 4 to 20 mA circuit, panel mounting, with optional HART® communication. Displays 4 to 20 mA or up to 4 HART® process variables</p> <p> For details, see "Technical Information", TI01043K/09/en</p>

Active barrier RN221N	<p>Active barrier with power supply for safe separation of 4 to 20 mA standard signal circuits. Has bidirectional HART® transmission and optional HART® diagnostics if transmitters are connected with monitoring of 4 to 20 mA signal or HART® status byte analysis and an E+H-specific diagnostic command.</p> <p> For details, see "Technical Information", TI00073R/09/en</p>
-----------------------	--

Documentation

Brief operating instructions - thermocouple assemblies

- TH53 Thermocouple assembly in thermowell (KA00196R/24/EN)
- TH54 (KA00197R/24/AE)
- TH55 (KA00198R/24/AE)

Technical information temperature transmitter iTEMP

- HART® TMT82 (TI01010T/09/)
- PROFIBUS PA TMT84 (TI00138R/09/)
- FOUNDATION Fieldbus™ TMT85 (TI00134R/09/)
- Field transmitter:
 - TMT162 HART® 5, PROFIBUS PA and FOUNDATION Fieldbus™ (TI00086R/09/EN)
 - TMT162 HART® 7 and SIL certification (TI01344T/09/EN)
 - TMT142 HART® (TI00107R/09/EN)
- PCP TMT181 (TI00070R/09/)
- Pt TMT180 (TI00088R/09/)
- HART® TMT182 (TI00078R/09/)

Application example - Technical information

- Temperature transmitter iTEMP PCP DIN rail TMT121 (TI00087R/09/EN)
- Technical information Cerabar S (TI00383P/00/EN)
- Technical information Deltabar S (TI384r/24/AE)

www.addresses.endress.com
