

Technical Information

TH11 and TH12

General purpose RTD with terminal head or conductor extension lead wires for process and laboratory applications



Application

The TH11 and TH12 temperature sensors are RTDs designed for use in the process industry or factory automation type of environment. They consist of a measurement probe with a RTD, insulation and sheath. Among other applications the sensors can be used on:

- Heat exchangers, power & recovery area
- Carbon regeneration furnace or dryers
- Flue Gas, compressor stations
- Process reactors

Head transmitter

All Endress+Hauser transmitters are available with enhanced accuracy and reliability compared to directly wired sensors. Easy customizing by choosing one of the following outputs and communication protocols:

- Analog output 4 to 20 mA, with or without HART
- PROFIBUS® PA
- FOUNDATION Fieldbus™

Field transmitter

Temperature field transmitters with HART® or FOUNDATION Fieldbus™ protocol for highest reliability in harsh industrial environments. Backlit display with large measured value, bargraph and fault condition indication for ease of reading.

Your benefits

- High flexibility due to modular assembly with standard terminal heads and customized immersion length
- One source shopping for temperature measurement solutions. World class transmitter with integrated sensor offering for heavy process industry applications. Remove and install straight out of the box!
- Improved galvanic isolation on most devices (2 kV)
- Simplified model structure: Competitively priced, offers great value. Easy to order and reorder. A single model number includes sensor and transmitter assembly for a complete point solution
- All iTEMP transmitters provide long term stability ≤ 0.05 % per year
- Fast response time with reduced/tapered tip form

Function and system design

Measuring principle

Resistance thermometer (RTD)

These resistance thermometers use a Pt100 temperature sensor according to IEC 60751. The temperature sensor is a temperature-sensitive platinum resistor with a resistance of 100 Ω at 0 °C (32 °F) and a temperature coefficient $\alpha = 0.003851 \text{ } ^\circ\text{C}^{-1}$.

There are generally two different kinds of platinum resistance thermometers:

- **Wire wound (WW):** Here, a double coil of fine, high-purity platinum wire is located in a ceramic support. This is then sealed top and bottom with a ceramic protective layer. Such resistance thermometers not only facilitate very reproducible measurements but also offer good long-term stability of the resistance/temperature characteristic within temperature ranges up to 600 °C (1 112 °F). This type of sensor is relatively large in size and it is comparatively sensitive to vibrations.
- **Thin film platinum resistance thermometers (TF):** A very thin, ultrapure platinum layer, approx. 1 μm thick, is vaporized in a vacuum on a ceramic substrate and then structured photolithographically. The platinum conductor paths formed in this way create the measuring resistance. Additional covering and passivation layers are applied and reliably protect the thin platinum layer from contamination and oxidation, even at high temperatures.

The primary advantages of thin film temperature sensors over wire wound versions are their smaller sizes and better vibration resistance. A relatively low principle-based deviation of the resistance/temperature characteristic from the standard characteristic of IEC 60751 can frequently be observed among TF sensors at high temperatures. As a result, the tight limit values of tolerance category A as per IEC 60751 can only be observed with TF sensors at temperatures up to 200 °C (392 °F).

Measuring system

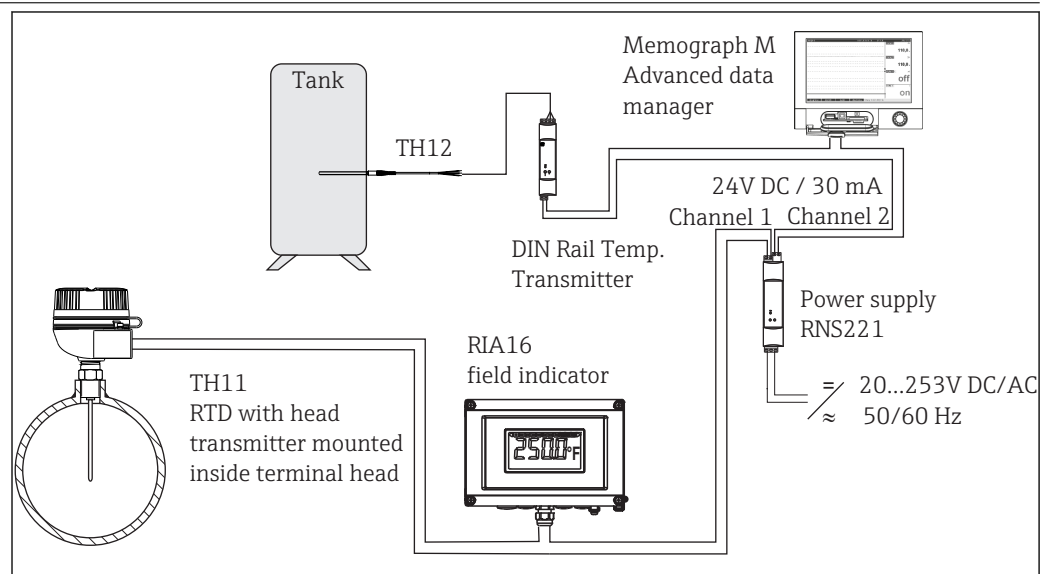

A0016255-EN

1 Application example

RIA16 Field indicator

The field indicator records an analog measuring signal and shows this on the display. The LC display shows the currently measured value digitally and as a bargraph with limit value violation signalling. The indicator is looped into the 4 to 20 mA circuit and obtains the required energy from there. Details see Technical Information. → 19

RNS221 Power supply

The power supply unit (24 V_{DC}, 30 mA) has two galvanically isolated outputs for supplying voltage to loop powered transmitters. The two channel device has a wide-range input for mains power, 20 to 253 VDC/AC, 50/60 Hz to be used in any electrical circuit. Details see Technical Information. → 19. The device is an UL recognized component.

RSG45 Memograph M, advanced data manager

Multichannel data recording system with multicolor TFT display (178 mm / 7" screen size), internal memory, external memory (SD card and USB stick), galvanically isolated universal inputs (U, I, TC, RTD, pulse, frequency), HART® inputs, digital inputs, transmitter power supply, limit relays, digital and analog outputs, communication interfaces (USB, Ethernet, RS232/485), optionally available with Modbus, Profibus DP or PROFINET I/O or EtherNet/IP. Details see Technical Information.
 →  19

Equipment architecture

The single and duplex element RTDs are designed to measure temperature in a variety of process and laboratory applications. These RTDs are specifically designed for use in two different process temperature ranges and they will provide accurate and repeatable temperature measurement through a broad range of -200 to 600 °C (-328 to 1 112 °F). Low range thin film RTDs -50 to 200 °C (-58 to 392 °F) are constructed using silver plated copper internal leads, PTFE wire insulations with potting compounds to resist moisture penetration. High range RTDs -200 to 600 °C (-328 to 1 112 °F) are constructed with nickel internal leads inside swaged MgO insulated cable to allow higher temperature measurements at the RTD element and to provide higher temperature lead protection along the sheath.

Measurement range

Construction	Model code (class and type of sensor)	Maximum range
Low temperature range (TF - thin film sensor)	TH11- ___ (A/C/E/G/J/L) _____	-50 to +200 °C (-58 to +392 °F)
	TH12- ___ (A/C/E/G/J/L) _____	
High temperature range (WW - wire wound sensor)	TH11- ___ (B/D/F/H/K/M) _____	-200 to +600 °C (-328 to +1 112 °F)
	TH12- ___ (B/D/F/H/K/M) _____	

Output

Output signal

Generally, the measured value can be transmitted in one of two ways:

- Directly-wired sensors - sensor measured values forwarded without a transmitter.
- Via all common protocols by selecting an appropriate Endress+Hauser iTEMP temperature transmitter. All the transmitters listed below are mounted directly in the terminal head or as field transmitter and wired with the sensory mechanism.

Family of temperature transmitters

Thermometers fitted with iTEMP transmitters are an installation-ready complete solution to improve temperature measurement by significantly increasing accuracy and reliability, when compared to direct wired sensors, as well as reducing both wiring and maintenance costs.

PC programmable head transmitters

They offer a high degree of flexibility, thereby supporting universal application with low inventory storage. The iTEMP transmitters can be configured quickly and easily at a PC. Endress+Hauser offers free configuration software which can be downloaded from the Endress+Hauser Website. More information can be found in the Technical Information.

HART® programmable head transmitters

The transmitter is a 2-wire device with one or two measuring inputs and one analog output. The device not only transfers converted signals from resistance thermometers and thermocouples, it also transfers resistance and voltage signals using HART® communication. It can be installed as an intrinsically safe apparatus in Zone 1 hazardous areas and is used for instrumentation in the terminal head (flat face) as per DIN EN 50446. Swift and easy operation, visualization and maintenance using universal device configuration tools like FieldCare, DeviceCare or FieldCommunicator 375/475. For more information, see the Technical Information.

PROFIBUS® PA head transmitters

Universally programmable head transmitter with PROFIBUS® PA communication. Conversion of various input signals into digital output signals. High accuracy over the complete ambient temperature range. The configuration of PROFIBUS PA functions and of device-specific parameters is performed via fieldbus communication. For more information, see the Technical Information.

FOUNDATION Fieldbus™ head transmitters

Universally programmable head transmitter with FOUNDATION Fieldbus™ communication. Conversion of various input signals into digital output signals. High accuracy over the complete

ambient temperature range. All transmitters are released for use in all important process control systems. The integration tests are performed in Endress+Hauser's "System World". For more information, see the Technical Information.

Advantages of the iTEMP transmitters:

- Dual or single sensor input (optionally for certain transmitters)
- Pluggable display (optionally for certain transmitters)
- Unsurpassed reliability, accuracy and long-term stability in critical processes
- Mathematical functions
- Monitoring of the thermometer drift, sensor backup functionality, sensor diagnostic functions
- Sensor-transmitter matching for dual sensor input transmitters, based on Callendar/Van Dusen coefficients

Field transmitter

Field transmitter with HART® or FOUNDATION Fieldbus™ communication and backlit display. Can be read easily from a distance, in sunlight and at night. Large measurement value, bargraph and fault indication displayed. Benefits are: dual sensor input, highest reliability in harsh industrial environments, mathematic functions, thermometer drift monitoring and sensor back-up functionality, corrosion detection.

Galvanic isolation

Galvanic isolation of Endress+Hauser iTEMP transmitters

Transmitter type	Sensor
TMT181 PCP	$\hat{U} = 3.75 \text{ kV AC}$
TMT182 HART®	$U = 2 \text{ kV AC}$
TMT162 HART® Field transmitter	$U = 2 \text{ kV AC}$
TMT82 HART®	$U = 2 \text{ kV AC}$
TMT84 PA	
TMT85 FF	

Power supply

Terminal assignment

Type of sensor connection TH11

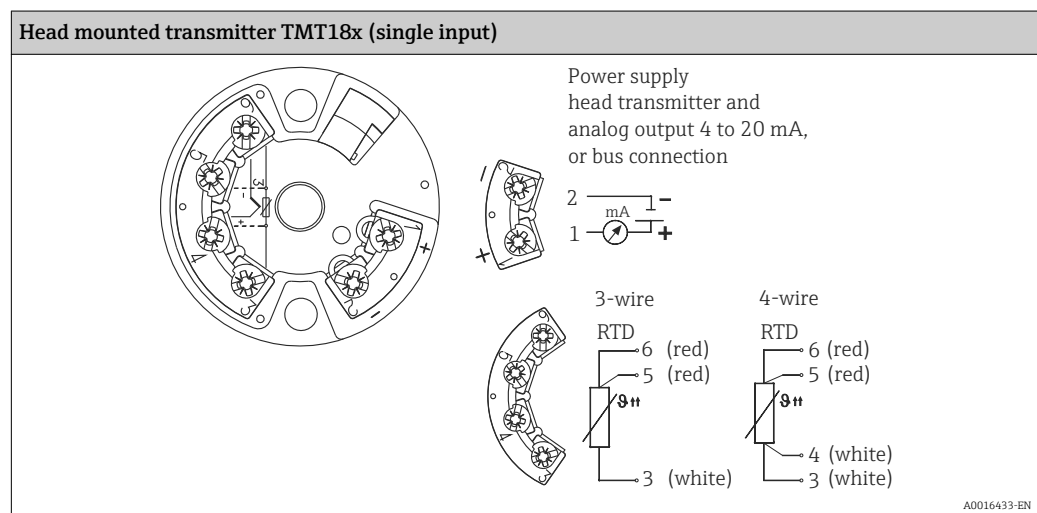

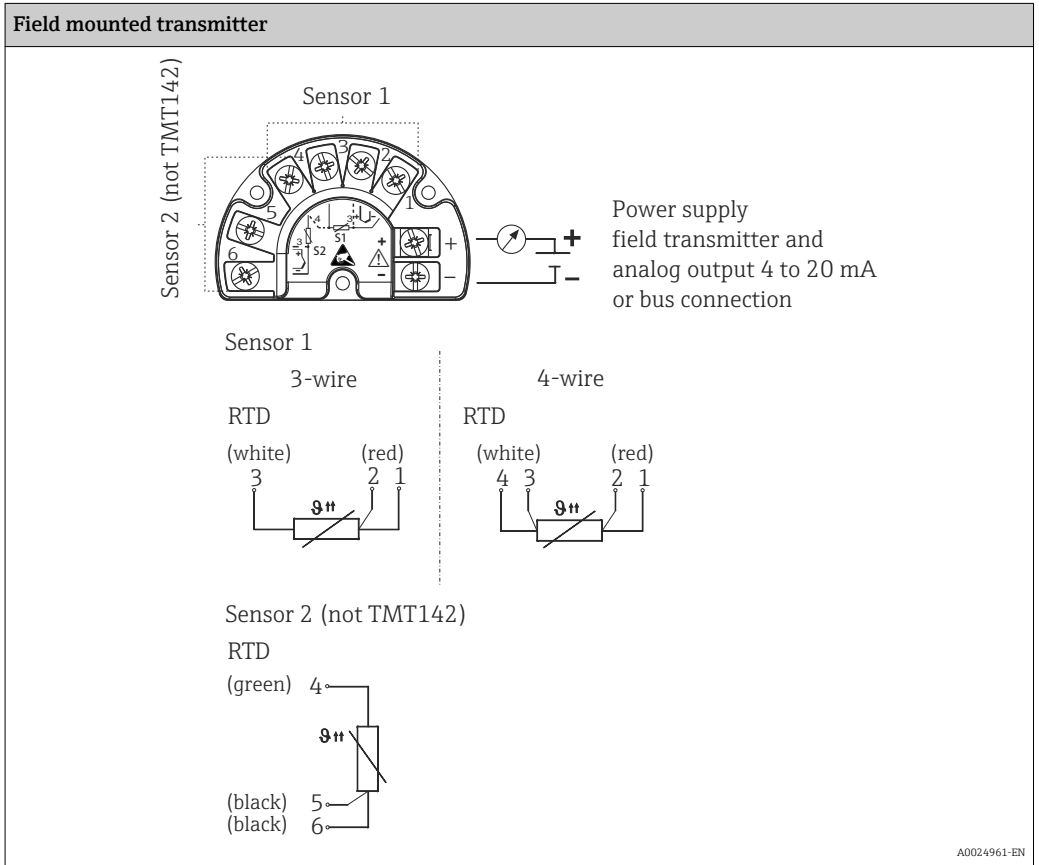
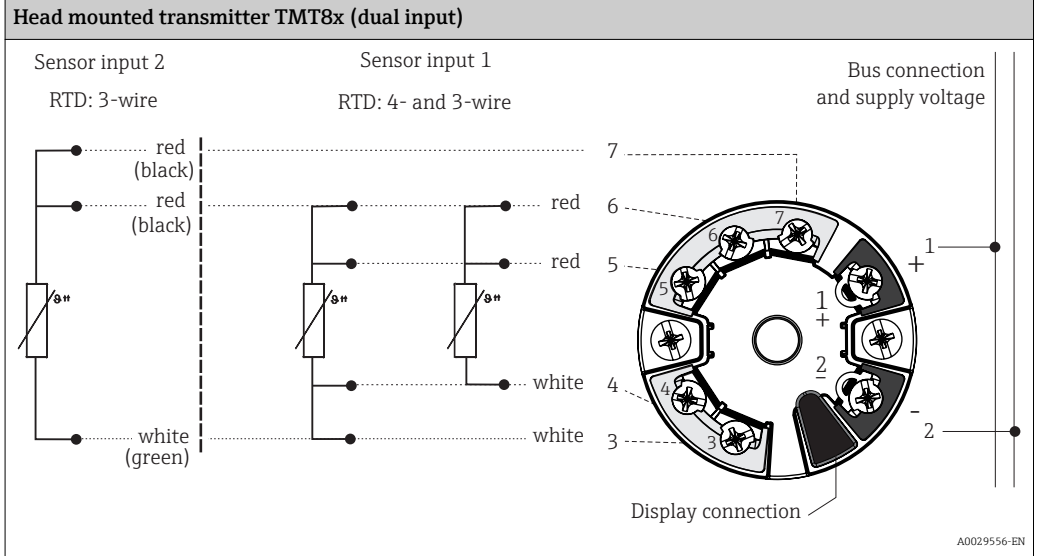

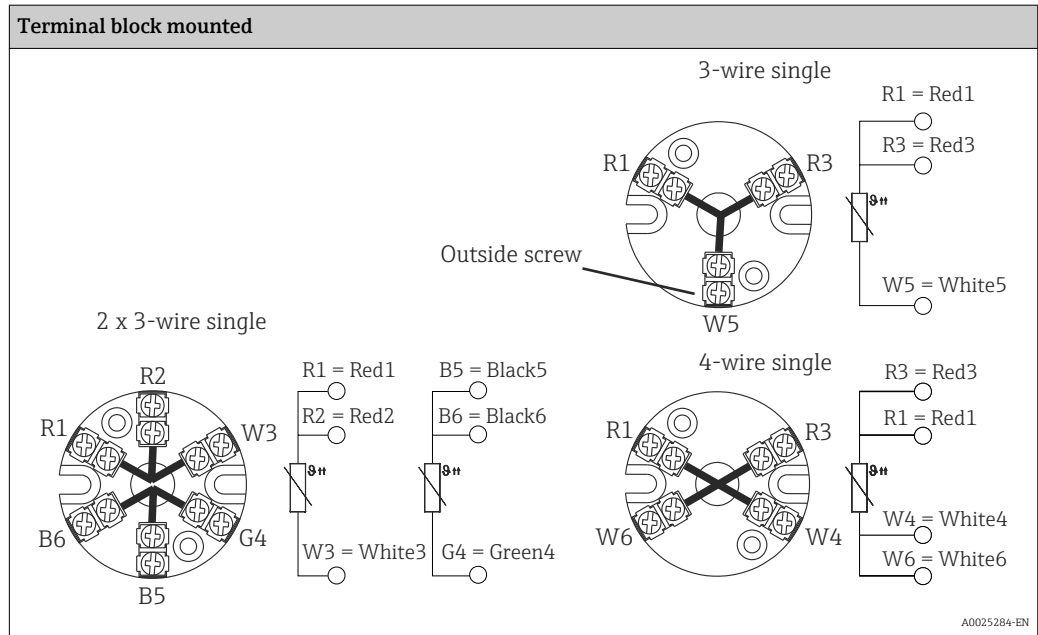

Integrated overvoltage protection

The integrated overvoltage protection module can be ordered as an optional extra ¹⁾. The module protects the electronics from damage from overvoltage. Overvoltage occurring in signal cables (e.g. 4 to 20 mA, communication lines (fieldbus systems) and power supply is diverted to ground. The functionality of the transmitter is not affected as no problematic voltage drop occurs.

Connection data:

Maximum continuous voltage (rated voltage)	$U_c = 42 V_{DC}$
Nominal current	$I = 0.5 A$ at $T_{amb.} = 80\text{ }^\circ C$ (176 °F)
Surge current resistance <ul style="list-style-type: none"> ▪ Lightning surge current D1 (10/350 μs) ▪ Nominal discharge current C1/C2 (8/20 μs) 	<ul style="list-style-type: none"> ▪ $I_{imp} = 1\text{ kA}$ (per wire) ▪ $I_n = 5\text{ kA}$ (per wire) $I_n = 10\text{ kA}$ (total)
Temperature range	-40 to +80 °C (-40 to +176 °F)
Series resistance per wire	1.8 Ω , tolerance $\pm 5\%$

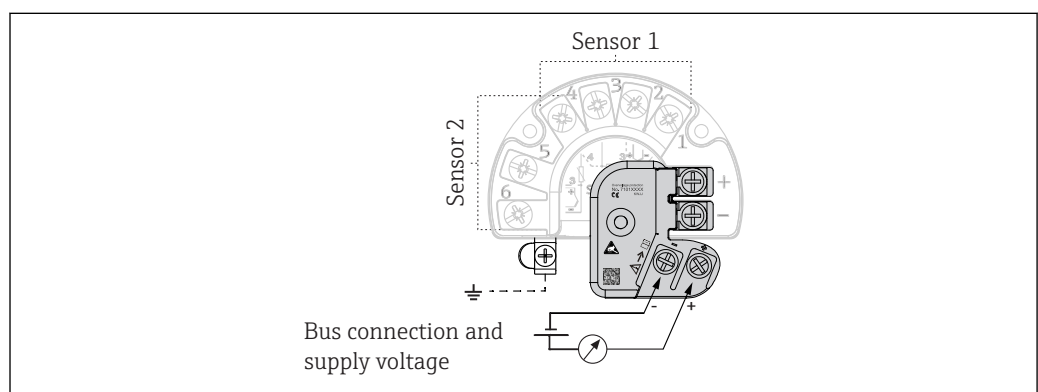

2 Electrical connection of the overvoltage protection

1) Available for the field transmitter with HART® 7 specification

Grounding

The device must be connected to the potential equalization. The connection between the housing and the local ground must have a minimum cross-section of 4 mm² (13 AWG) . All ground connections must be secured tightly.

Wire specifications

TH11

24 AWG, 19 strand silver plated copper with 0.010 in PTFE extruded outer. 1/8 in sensors have 28 AWG seven strand wires with the same extrusion.

TH12

24 AWG, seven strand silver plated copper with 0.010 in PTFE, then 0.015 in FEP outer jacket, 1/8 in sensors are 28 AWG, seven strand SPC, 0.010 in PTEFE, 0.015 in FEP white outer jacket. Flex armor is 0.272 in nominal OD, 304SS 0.010 in thick, square lock style.

The maximum temperature for the extension cable is +200 °C (+392 °F)

Electrical connection

Flying leads, standard 139.7 mm (5.5 in) for wiring in connection head, head mounted transmitter or terminal block mounted, and for wiring with TMT162 or TMT142 assemblies

Design of leads

Flying leads 139.7 mm (5.5 in) with brass crimped sleeves

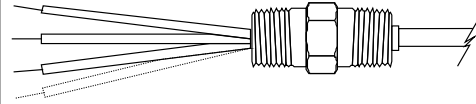

A0026119

Performance characteristics

Response time

63% response time per ASTM E644

Construction	RTD $\phi 1/8$ "	RTD $\phi 3/16$ "	RTD $\phi 1/4$ "	RTD $\phi 3/8$ " reduced $3/16$ "
High temperature range	2 s	2 s	3 s	Not available
Low temperature range	3 s	7 s	9 s	6 s

Response time for the sensor assembly without transmitter.

Accuracy

RTD resistance thermometer as per IEC 60751

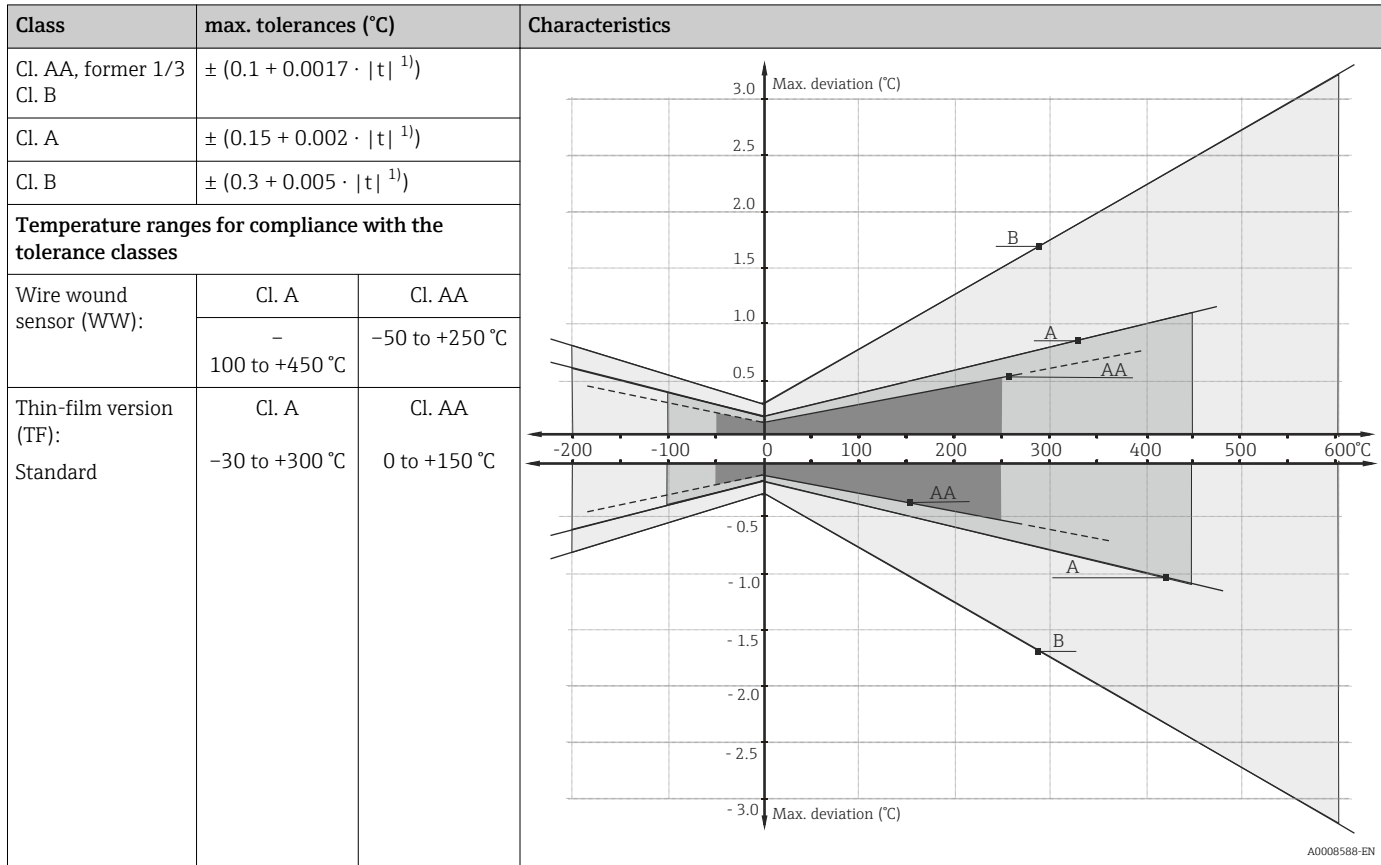

1) |t| = absolute value °C

In order to obtain the maximum tolerances in °F, the results in °C must be multiplied by a factor of 1.8.

Transmitter long-term stability $\leq 0.1 \text{ }^\circ\text{C}$ (0.18 °F)/year or $\leq 0.05\%$ / year
Data under reference conditions; % relates to the set span. The larger value applies.

Dielectric strength The units are factory tested with 500 V_{AC} for one minute between live parts (terminals) and exposed non-current-carrying metal parts (e.g. probe sheath).

Self heating RTD elements are passive resistances that are measured using an external current. This measurement current causes a self-heating effect in the RTD element itself which in turn creates an additional measurement error. In addition to the measurement current, the size of the measurement error is also affected by the temperature conductivity and flow velocity of the process. This self-heating error is negligible when an Endress+Hauser iTEMP temperature transmitter (very small measurement current) is connected.

Calibration specifications The manufacturer provides comparison temperature calibrations from -20 to +300 °C (-4 to +572 °F) on the international temperature scale of 1990. Calibrations are traceable to standards maintained by the National Institute of Standards and Technology (NIST). Calibration services are in conformance with ASTM E220, IEC 17025 and ANSI/NCSL Z540-1-1994. The report of calibration is referenced to the serial number of the RTD assembly.
Three point calibrations are provided, given that the specified temperatures are within the recommended range and the minimum length requirements are met as specified. The minimum length is 6 in.

Installation

Orientation No restrictions

Installation instructions

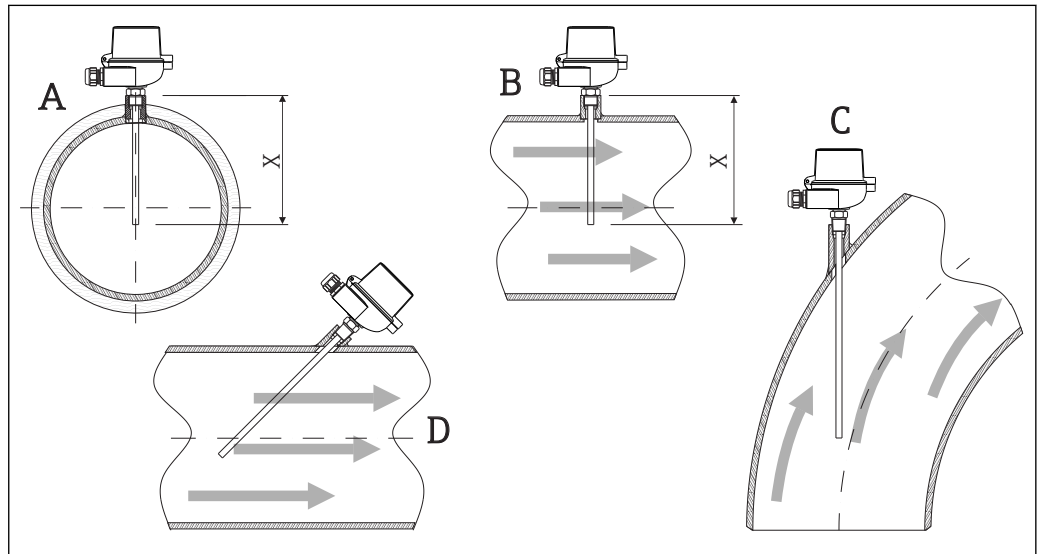

A0009538

3 Installation examples

A-B In pipes with a small cross section the sensor tip should reach or extend slightly past the center line of the pipe (=X).
 C-D Tilted installation

The immersion length of the thermometer influences the accuracy. If the immersion length is too small then errors in the measurement are caused by heat conduction via the process connection and the container wall. If installing into a pipe then the immersion length should be at least half of the pipe diameter. A further solution could be an angled (tilted) installation (see C-D). When determining the immersion length all thermometer parameters and the process to be measured must be taken into account (e.g. flow velocity, process pressure).

- Installation possibilities: Pipes, tanks or other plant components
- Minimum immersion length should be 10 times the OD of the sheath, nominal.

Environment

Ambient temperature range

Terminal head	Temperature in °C (°F)
Without mounted head transmitter	Depends on the terminal head used and the cable gland or fieldbus connector, see 'Terminal heads' section
With mounted head transmitter	-40 to 85 °C (-40 to 185 °F) SIL mode (HART 7 transmitter): -40 to 70 °C (-40 to 158 °F)
With mounted head transmitter and display	-20 to 70 °C (-4 to 158 °F)
With mounted field transmitter	<ul style="list-style-type: none"> ■ Without display: -40 to 85 °C (-40 to 185 °F) ■ With display and/or integrated overvoltage protection module: -40 to +80 °C (-40 to +176 °F) ■ SIL mode: -40 to +75 °C (-40 to +167 °F)

Shock and vibration resistance

4 g/2 to 150 Hz as per IEC 60068-2-6

Process

Process pressure limits

p/T load curve example according to Dittrich

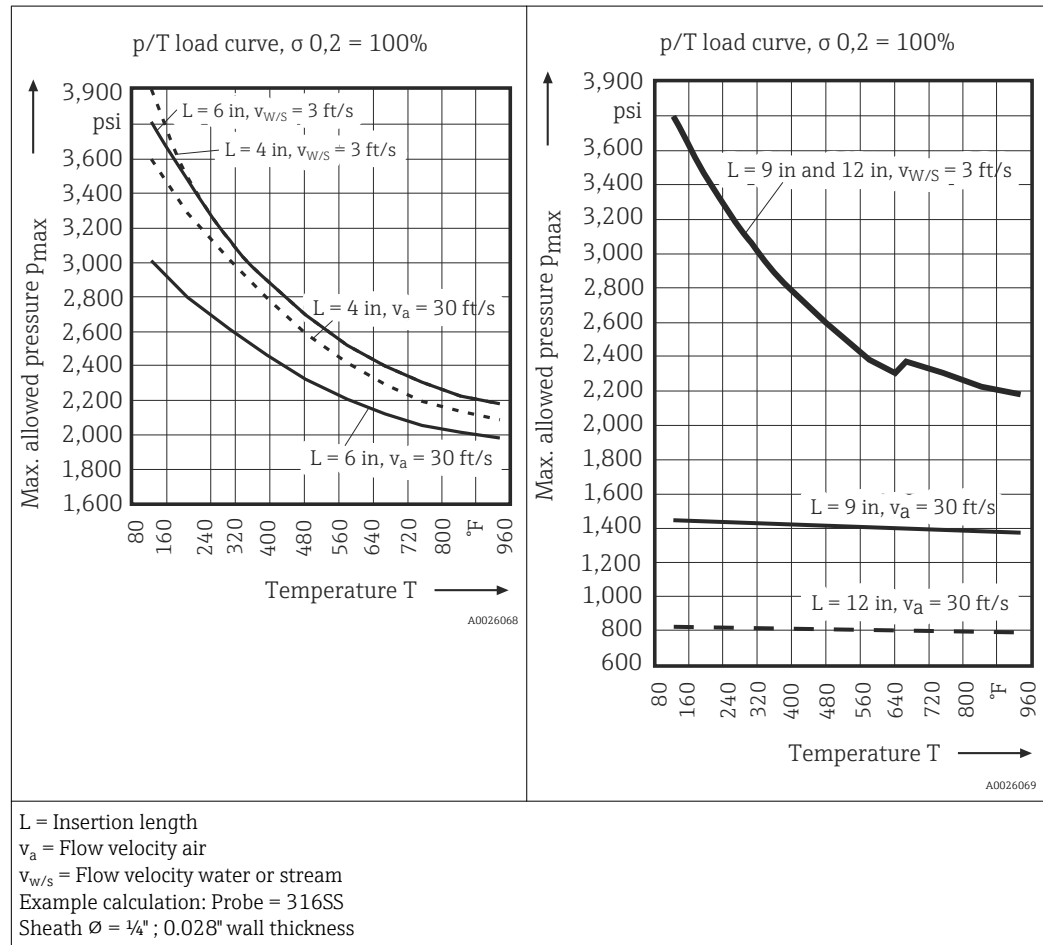

i Avoid resonance frequency as this will cause damage to the probe!

- L = 4 and 6 in:
Resonance frequency occurs when permanent flow velocity is at 18.1, 22.6 or 27.1 ft/s (air) for 6 in and/or 40.5, 50.6 or 60.8 ft/s (air) for 4 inch probe (T = 482 °F, p = 2700/2600 psi).
- L = 9 and 12 in:
Resonance frequency occurs when permanent flow velocity is at 8.1, 10.1 or 12.1 ft/s (air) for 9 inch and/or 4.6, 5.7 or 6.8 ft/s (air) for 12 inch probe (T = 482 °F, p = 2600 psi).

i The calculation was done for pipes only, for MgO insulated sensors the values might be higher. In any case for different lengths, other materials, variation in sheath diameter or wall thicknesses, stress analysis is recommended. Failures are caused by forces imposed by static pressure, steady state flow, and vibration.

Max. allowable process pressure (PSIG) for instrumentation with one time adjustable compression fittings.

Temperature °C (°F)	1/8" NPT and 1/4" NPT compression fitting			
	Sheath $\varnothing = 1/8"$	Sheath $\varnothing = 3/16"$	Sheath $\varnothing = 1/4"$	Sheath $\varnothing = 3/8"$ ¹⁾
-28 to 204 °C (-20 to 300 °F)	2850	3150	3350	3900
204 °C (400 °F)	2750	3050	3250	3800
260 °C (500 °F)	2550	2850	3000	3500
316 °C (600 °F)	2400	2700	2850	3300
371 °C (700 °F)	2350	2600	2750	3200

Temperature	1/8" NPT and 1/4" NPT compression fitting			
°C (°F)	Sheath $\varnothing = 1/8"$	Sheath $\varnothing = 3/16"$	Sheath $\varnothing = 1/4"$	Sheath $\varnothing = 3/8"$ ¹⁾
427 °C (800 °F)	2 300	2 550	2 650	3 100
482 °C (900 °F)	2 200	2 450	2 600	3 050
538 °C (1 000 °F)	2 100	2 300	2 450	2 850

1) not available with compression fittings 1/8" NPT

i Re-adjustable compression fittings are not intended to be used for pressure retaining applications and should only be used for the mechanical holding of sensors.

Mechanical construction

Design, dimensions

All dimensions in inches. For the values related to this graphic please refer to the tables and equations below.

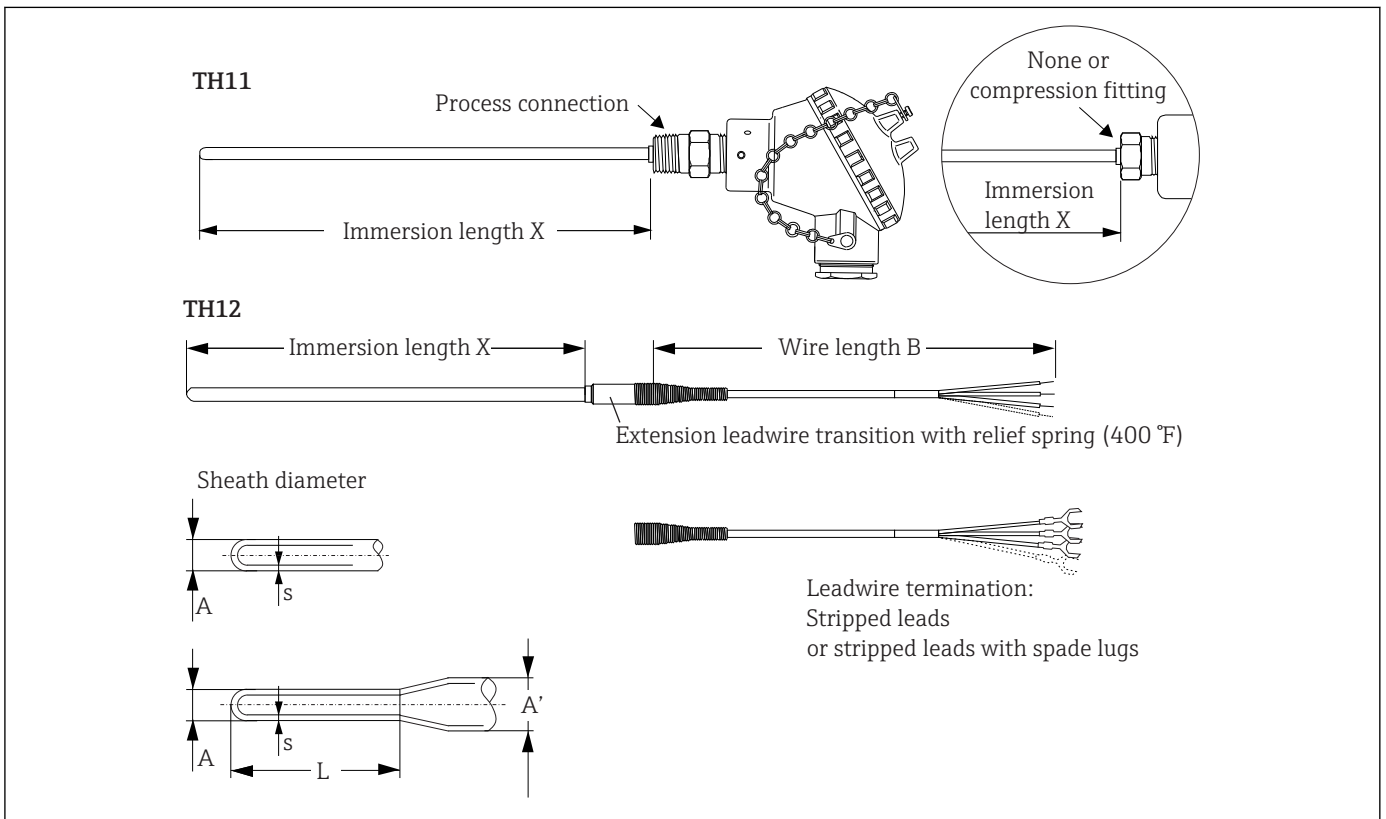

4 For values related to this graphic please refer to the table below.

Dimensions in inches

Immersion length X		Wire length B	Sheath diameter A	Wall thickness S
TH11	TH12			
4, 6, 9, 12	6, 12, 18, 24	48, 72, 120	$\varnothing 1/8$	0.014
			$\varnothing 3/16$	0.022
			$\varnothing 1/4$	0.029
Specified length: 2 to 96 in 1/2 in increments		Specified length: 12 to 300 in 12 in increments	$\varnothing 3/8$	0.045

Weight 0.5 to 2.5 kg (1 to 5.5 lb)

Material Process connections and sheath.

The temperatures for continuous operation specified in the following table are only intended as reference values for use of the various materials in air and without any significant compressive load. The maximum operation temperatures are reduced considerably in some cases where abnormal conditions such as high mechanical load occur or in aggressive media.

Material name	Short form	Recommended max. temperature for continuous use in air	Properties
AISI 316/1.4401	X2CrNiMo17-12-2	650 °C (1 200 °F)	<ul style="list-style-type: none"> ■ Austenitic, stainless steel ■ High corrosion resistance in general ■ Particularly high corrosion resistance in chlorine-based and acidic, non-oxidizing atmospheres through the addition of molybdenum (e.g. phosphoric and sulfuric acids, acetic and tartaric acids with a low concentration)

Process connection

Compression fitting

All dimensions in inch

Re-adjustable compression fittings in stainless steel with FEP ferrule

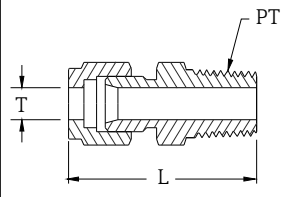
Type of fitting	Tube size - Outer diameter (T) in inch	Process thread (PT) in inch	Length (L) in inch
 <p style="text-align: right; margin-right: 50px;">A0026151</p>	1/8	1/8" NPT	1 1/4
	3/16	1/8" NPT	1 1/4
	1/4	1/4" NPT	2 1/2
	3/8	1/4" NPT	2 1/2
	1/4	1/8" NPT	1 1/4
	1/8	1/4" NPT	1 9/16
	3/16	1/4" NPT	1 9/16

One-time adjustable compression fittings in stainless steel with SS ferrule

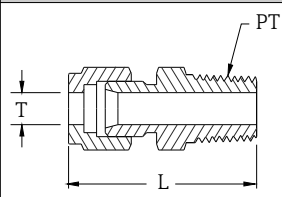
Type of fitting	Tube size - Outer diameter (T) in inch	Process thread (PT) in inch	Length (L) in inch
 <p style="text-align: right; margin-right: 50px;">A0026151</p>	1/8	1/8" NPT	1 1/4
	3/16	1/8" NPT	1 1/4
	1/4	1/8" NPT	1 1/4
	1/8	1/4" NPT	1 7/16
	3/16	1/4" NPT	1 1/2
	1/4	1/4" NPT	1 9/16
	3/8	1/4" NPT	1 5/8

Housing

Terminal heads

All terminal heads have an internal shape and size in accordance with DIN EN 50446, flat face and a thermometer connection with a 1/2" NPT thread. All dimensions in mm (in). Specifications without head transmitter installed. For ambient temperatures with head transmitter installed, see the 'Environment' section.

As a special feature, Endress+Hauser offers terminal heads with optimized terminal accessibility for easy installation and maintenance.

 Some of the specifications listed below may not be available on this product line.

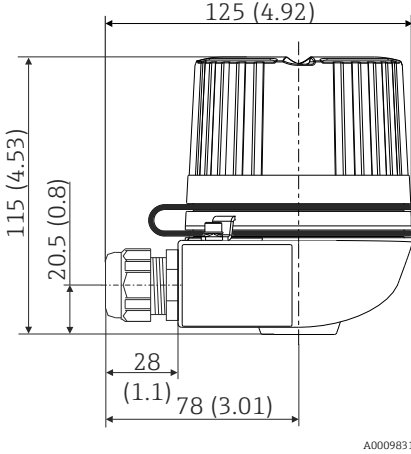
TA30H with display window in cover	Specification
 <p style="text-align: right; font-size: small;">A0009831</p>	<ul style="list-style-type: none"> ▪ Flameproof (XP) version, explosion-protected, captive screw cap, available with one or two cable entries ▪ Degree of protection: IP 66/68, NEMA Type 4x Encl. Ex-version: IP 66/67 ▪ Temperature: -50 to +150 °C (-58 to +302 °F) for rubber seal without cable gland (observe max. permitted temperature of cable gland!) ▪ Material: <ul style="list-style-type: none"> - Aluminum with polyester powder coating - Stainless steel 316L without coating ▪ Thread: ½" NPT, ¾" NPT, M20x1.5, G½" ▪ Extension neck/thermowell connection: ½" NPT ▪ Color of aluminum head: blue, RAL 5012 ▪ Color of aluminum cap: gray, RAL 7035 ▪ Weight: <ul style="list-style-type: none"> - Aluminum: approx. 860 g (30.33 oz) - Stainless steel: approx. 2 900 g (102.3 oz) ▪ Head transmitter optionally available with TID10 display

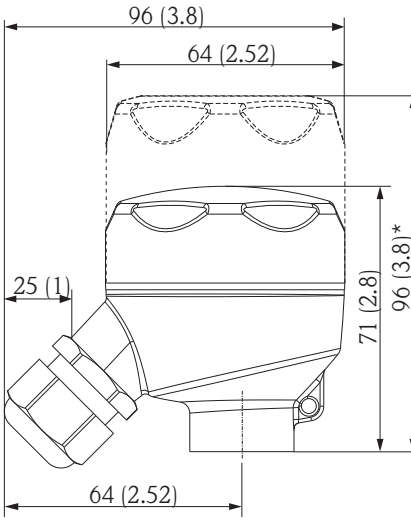
TA30R (optionally with display window in cover)	Specification
 <p style="text-align: right; font-size: small;">A0017145</p> <p>* Dimensions of version with display window in cover</p>	<ul style="list-style-type: none"> ▪ Degree of protection - standard version: IP69K (NEMA Type 4x encl.) ▪ Degree of protection - version with display window: IP66/68 (NEMA Type 4x encl.) ▪ Temperature: -50 to +130 °C (-58 to +266 °F) without cable gland ▪ Material: stainless steel 316L, abrasive-blasted or polished ▪ Seals: EPDM ▪ Display window: polycarbonate (PC) ▪ Cable entry thread ½" NPT and M20x1.5 ▪ Weight <ul style="list-style-type: none"> - Standard version: 360 g (12.7 oz) - Version with display window: 460 g (16.23 oz) ▪ Display window in cover optionally for head transmitter with display TID10 ▪ Protection armature connection: M24x1.5 or ½" NPT ▪ Ground terminal: internal in standard version; external terminal optionally available ▪ Available in conjunction with 3-A marked sensors

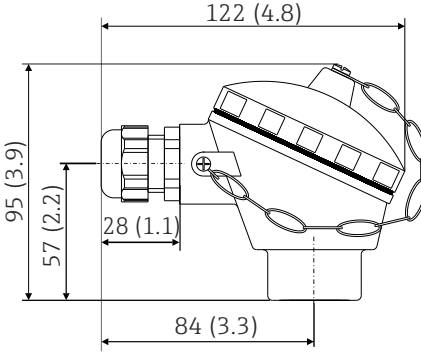
TU401	Specification
 <p style="text-align: right; font-size: small;">A0008669</p>	<ul style="list-style-type: none"> ■ Protection class: IP65 (NEMA Type 4x encl.) ■ Temperature: -40 to 130 °C (-40 to 266 °F) silicone, up to 100 °C (212 °F) rubber seal without cable gland (observe max. permitted temperature of the cable gland!) ■ Material: aluminum alloy with polyester or epoxy coating, rubber or silicone seal under the cover ■ Cable entry: ½" NPT, ¾" NPT or plug 7/8" FF ■ Protection armature connection: M24x1.5, G 1/2" or NPT 1/2" ■ Head color: blue, RAL 5012 ■ Cap color: gray, RAL 7035 ■ Weight: 300 g (10.58 oz)

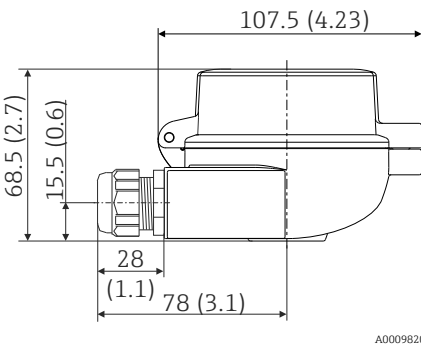
TU401 (TA30A style)	Specification
 <p style="text-align: right; font-size: small;">A0009820</p>	<ul style="list-style-type: none"> ■ Available with one or two cable entries ■ Protection class: IP66/68 (NEMA Type 4x encl.) ■ Temperature: -50 to +150 °C (-58 to +302 °F) without cable gland ■ Material: aluminum, polyester powder coated ■ Seals: silicone ■ Threaded cable entry: ½" NPT, ¾" NPT or plug 7/8" FF ■ Protection armature connection: M24x1.5 ■ Head color: blue, RAL 5012 ■ Cap color: gray, RAL 7035 ■ Weight: 330 g (11.64 oz) ■ Ground terminal, internal and external ■ With 3-A symbol

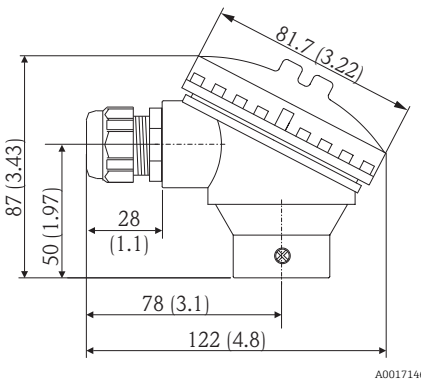
TU401 (TA30S style)	Specification
 <p style="text-align: right; font-size: small;">A0017146</p>	<ul style="list-style-type: none"> ■ Degree of protection: IP65 (NEMA Type 4x encl.) ■ Temperature: -40 to +85 °C (-40 to +185 °F) without cable gland ■ Material: polypropylene (PP), FDA-compliant, seals: O-ring EPDM ■ Cable entry thread: ¾" NPT, ½" NPT) or or plug 7/8" FF ■ Protective assembly connection: ½" NPT ■ Color: white ■ Weight: approx. 100 g (3.5 oz) ■ Ground terminal: only internal via auxiliary terminal <p style="background-color: yellow; margin: 5px 0;">⚠ CAUTION</p> <p>Potential electrostatic charging hazard</p> <ul style="list-style-type: none"> ▶ Not recommended for use in hazardous (classified) locations.

Field transmitters

Temperature field transmitter iTEMP TMT162

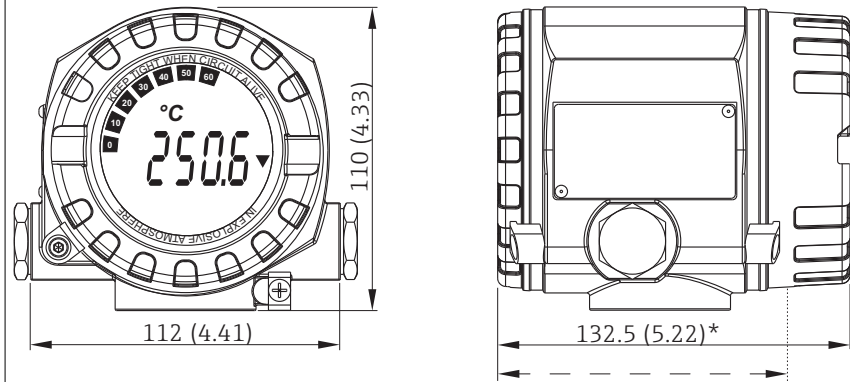

A0024608

* Dimensions without display = 112 mm (4.41 in)

- Separate electronics compartment and connection compartment
- Protection class: IP67, NEMA type 4x
- Material: Die-cast aluminum housing AlSi10Mg with powder coating on polyester base, 316L
- Display rotatable in 90° increments
- Cable entry: 2x 1/2" NPT
- Brilliant backlit display with ease of visibility in bright sunshine or pitch darkness
- Gold plated terminals to avoid corrosion and additional measurement errors
- SIL certification as per IEC 61508:2010 (HART-protocol)

Temperature field transmitter iTEMP TMT162 for hygienic applications

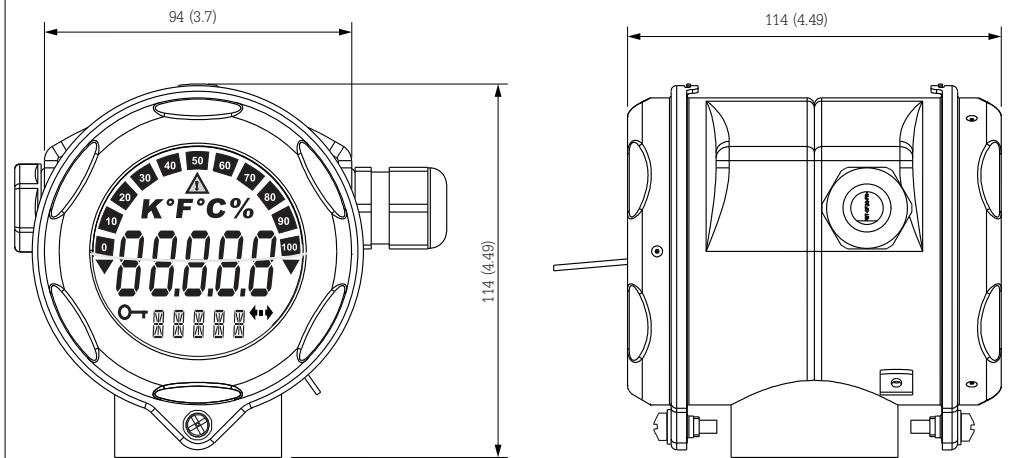

A0016655

* Dimensions without display = 112 mm (4.41 in)

- Material: Stainless steel 1.4435 (AISI 316L) for hygienic applications (T17 housing)
- Separate electronics compartment and connection compartment
- Display rotatable in 90° increments
- Cable entry: 2 x 1/2" NPT
- Degree of protection (IP69K)
- Brilliant backlit display with ease of visibility in bright sunshine or pitch darkness
- Gold plated terminals to avoid corrosion and additional measurement errors

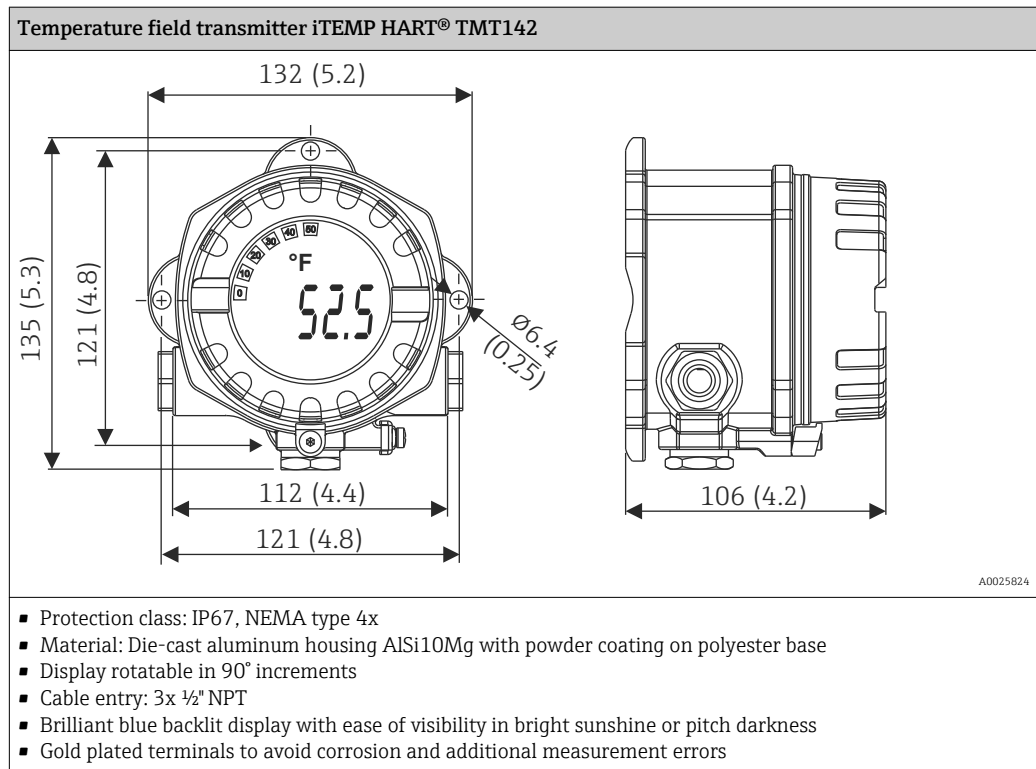

Certificates and approvals

CE mark The measuring system meets the legal requirements of the applicable EC guidelines. These are listed in the corresponding EC Declaration of Conformity together with the standards applied. The manufacturer confirms successful testing of the device by affixing to it the CE mark.

Other standards and guidelines

- IEC 60529: Degree of protection of housing (IP code)
- IEC/EN 61010-1: Safety requirements for electrical equipment for measurement, control, and laboratory use.
- ASTM E644: American society for testing and materials, standard test methods for testing industrial resistance thermometers.
- NEMA - ANSI / NEMA 250: Standardization association for the electrical industry.
- IEC 60751: Industrial platinum resistance thermometer
- ASME PTC 19.3 - 1974: Performance test codes

CSA GP The installed and assembled transmitters (iTEMP Series) are CSA GP approved.

Ordering information

Detailed ordering information is available from the following sources:

- In the Product Configurator on the Endress+Hauser website: www.endress.com -> Click "Corporate" -> Select your country -> Click "Products" -> Select the product using the filters and search field -> Open product page -> The "Configure" button to the right of the product image opens the Product Configurator.
- From your Endress+Hauser Sales Center: www.addresses.endress.com



Product Configurator - the tool for individual product configuration



- Up-to-the-minute configuration data
- Depending on the device: Direct input of measuring point-specific information such as measuring range or operating language
- Automatic verification of exclusion criteria
- Automatic creation of the order code and its breakdown in PDF or Excel output format
- Ability to order directly in the Endress+Hauser Online Shop

Accessories

Various accessories, which can be ordered with the device or subsequently from Endress+Hauser, are available for the device. Detailed information on the order code in question is available from your local Endress+Hauser sales center or on the product page of the Endress+Hauser website:

www.endress.com.

Device-specific accessories	TU301	Threaded compression fitting Order code: TU301
	Mounting bracket	SS316L, for tube 1.5...3" Order code: 51007995
	Adapter	M20x1.5 - 1/2" NPT cable entry Order code: 51004387
	Cable gland	1/2" NPT, D4.5-8.5, IP 68 Order code: 51006845
	Integrated overvoltage protection module	The module protects the electronics from overvoltage. Available for TMT162 housing (not T17 hygienic version).
Communication-specific accessories	Configuration kit TXU10	Configuration kit for PC-programmable transmitter with setup software and interface cable for PC with USB port Order code: TXU10-xx
	Commubox FXA195 HART	For intrinsically safe HART communication with FieldCare via the USB interface. For details, see "Technical Information" TI00404F
	Commubox FXA291	Connects Endress+Hauser field devices with a CDI interface (= Endress+Hauser Common Data Interface) and the USB port of a computer or laptop. For details, see "Technical Information" TI00405C
	Wireless HART adapter SWA70	Is used for the wireless connection of field devices. The WirelessHART adapter can be easily integrated into field devices and existing infrastructures, offers data protection and transmission safety and can be operated in parallel with other wireless networks with minimum cabling complexity. For details, see Operating Instructions BA061S





Field Xpert SFX350	<p>Field Xpert SFX350 is a mobile computer for commissioning and maintenance. It enables efficient device configuration and diagnostics for HART and FOUNDATION Fieldbus devices in the non-Ex area.</p> <p> For details, see Operating Instructions BA01202S</p>
Field Xpert SFX370	<p>Field Xpert SFX370 is a mobile computer for commissioning and maintenance. It enables efficient device configuration and diagnostics for HART and FOUNDATION Fieldbus devices in the non-Ex area and the Ex area.</p> <p> For details, see Operating Instructions BA01202S</p>

Service-specific accessories

Accessories	Description
Applicator	<p>Software for selecting and sizing Endress+Hauser measuring devices:</p> <ul style="list-style-type: none"> Calculation of all the necessary data for identifying the optimum measuring device: e.g. pressure loss, accuracy or process connections. Graphic illustration of the calculation results <p>Administration, documentation and access to all project-related data and parameters over the entire life cycle of a project.</p> <p>Applicator is available:</p> <ul style="list-style-type: none"> Via the Internet: https://portal.endress.com/webapp/applicator On CD-ROM for local PC installation.
Configurator	<p>Product Configurator - the tool for individual product configuration</p> <ul style="list-style-type: none"> Up-to-the-minute configuration data Depending on the device: Direct input of measuring point-specific information such as measuring range or operating language Automatic verification of exclusion criteria Automatic creation of the order code and its breakdown in PDF or Excel output format Ability to order directly in the Endress+Hauser Online Shop <p>The Configurator is available on the Endress+Hauser website: www.endress.com -> Click "Corporate" -> Select your country -> Click "Products" -> Select the product using the filters and the search field -> Open the product page -> The "Configure" button to the right of the product image opens the Product Configurator.</p>
W@M	<p>Life cycle management for your plant</p> <p>W@M supports you with a wide range of software applications over the entire process: from planning and procurement, to the installation, commissioning and operation of the measuring devices. All the relevant device information, such as the device status, spare parts and device-specific documentation, is available for every device over the entire life cycle.</p> <p>The application already contains the data of your Endress+Hauser device. Endress+Hauser also takes care of maintaining and updating the data records.</p> <p>W@M is available:</p> <ul style="list-style-type: none"> Via the Internet: www.endress.com/lifecyclemanagement On CD-ROM for local PC installation.
FieldCare SFE500	<p>FDT-based plant asset management tool from Endress+Hauser.</p> <p>It can configure all smart field units in your system and helps you manage them. By using the status information, it is also a simple but effective way of checking their status and condition.</p> <p> For details, see Operating Instructions BA00027S and BA00065S</p>

DeviceCare SFE100	<p>Configuration tool for devices via fieldbus protocols and Endress+Hauser service protocols.</p> <p>DeviceCare is the tool developed by Endress+Hauser for the configuration of Endress+Hauser devices. All smart devices in a plant can be configured via a point-to-point or point-to-bus connection. The user-friendly menus enable transparent and intuitive access to the field devices.</p> <p> For details, see Operating Instructions BA00027S</p>
-------------------	---

System products

Accessories	Description
Field indicator RIA16	<p>Loop-powered field indicator for looping into the 4 to 20 mA current circuit. Optional with aluminum housing for Ex application</p> <p> For details, see the "Technical Information", TI00144R/09/EN</p>
Process display RIA15	<p>Process display, digital loop-powered display for 4 to 20 mA circuit, panel mounting, with optional HART® communication. Displays 4 to 20 mA or up to 4 HART® process variables</p> <p> For details, see "Technical Information", TI01043K/09/en</p>
Power supply RNS221	<p>Supply of two 2 wire sensors or transmitters, galvanically isolated, valid for non-Ex areas. Using the HART® communication sockets bi-directional communication to SMART transmitters.</p> <p> For details, see "Technical Information", TI00081R/09/en</p>
Active barrier RN221N	<p>Active barrier with power supply for safe separation of 4 to 20 mA standard signal circuits. Has bidirectional HART® transmission and optional HART® diagnostics if transmitters are connected with monitoring of 4 to 20 mA signal or HART® status byte analysis and an E+H-specific diagnostic command.</p> <p> For details, see "Technical Information", TI00073R/09/en</p>
Advanced data manager Memograph M, RSG45	<p>A flexible and powerful system for organizing electronic acquisition, display, recording, analysis, remote transmission and archiving of analog and digital input signals as well as calculated values.</p> <p> For details, see "Technical Information", TI01180R/09/en</p>

Documentation

Brief operating instructions

- TH11 RTD temperature sensor, KA00178R/24/EN
- TH12 RTD temperature sensor (with cable), KA179R/24/AE

Technical Information temperature transmitter iTEMP

- HART® TMT82, TI01010T/09/EN
- PROFIBUS PA TMT84, TI00138R/09/EN
- FOUNDATION Fieldbus™ TMT85, TI00134R/09/EN
- Field transmitter:
 - TMT162 HART® 5, PROFIBUS PA and FOUNDATION Fieldbus™, TI00086R/09/EN
 - TMT162 HART® 7 and SIL certification, TI01344T/09/EN
 - HART® TMT142, TI00107R/09/EN
- Pt TMT180, TI00088R/09/EN
- PCP TMTT181, TI00070R/09/EN
- HART® TMT182, TI00078R/09/EN

www.addresses.endress.com
