



The TEX-DEW200 has been designed for wet/dry bulb relative humidity applications, and accepts RTD 385/392 PT100 inputs.

It features dual 4–20mA analog output for humidity and temperature, and a dual display for simultaneous viewing of these variables.

The TEX-DEW200 has been designed for ease of use, with scrolling text prompts that guide you step-by-step through the setup process.

## Order Codes

**TEX-DEW200** Humidity/Temperature  
with 2 x 4–20mA analog outputs

- HV 85–265V AC / 95–370V DC
- LV 15–48V AC / 10–72V DC

### Options

- R2 2 x relay outputs
- R4 4 x relay outputs
- S2R 1 x RS232 (RJ11 terminal)
- S4S 1 x RS485 (screw terminal)

## Contents

<b>1 - Specifications</b> .....	2
<b>2 - Front Panel &amp; Display</b> .....	3
<b>3 - Wiring</b> .....	4
<b>4 - Dimensions &amp; Installation</b> .....	7
<b>5 - Input Setup &amp; Calibration</b> .....	9
<b>6 - Setpoint Setup</b> .....	16
<b>7 - Setpoint Open Access</b> .....	18
<b>8 - Reset PIN Numbers / View Firmware Version</b> .....	19
<b>A - Appendix A - Serial Modes</b> .....	20

## 1

## SPECIFICATIONS

## Input

**Sensor input** 1 x wet bulb, 1 x dry bulb.  
Dual 3-wire RTD (385/392), PT100

**Power supply** HV= 85–265V AC / 95–370V DC, or LV= 15–48V AC / 10–72V DC

**Excitation** 24V DC (50mA max)

**Sampling rate** 2.5Hz

**Resolution** 0.025% full scale, 16 bit

**Accuracy** 0.05% of reading

**Ambient drift** 50ppm/°C typical

**Temperature units** °F or °C

**Noise rejection** 50/60Hz

## Analog Output

**Number of analog outputs** 2

**Analog output type** Isolated 16 bit  
4–20mA

## Relay Output

OPTIONAL

**Number of relay outputs** None, 2, or 4

**Relay output type** 5A form A (3A 240V AC max or 3A 30V DC max)

## Comm Port

OPTIONAL

**Number of serial ports** None or 1

**Serial port options** Isolated RS232 (RJ terminal) or RS485 (screw terminal)

## Programming

**Front panel buttons** Up, Down, P (Prog/Enter), plus 2 Menu buttons (F)

**Factory calibration** 385 RTD, 0–100°C (32–212°F)

**Security** Input and setpoint setups are independently accessible and PIN protected

## Display

**Display type** LED display, 5 buttons

**LED indicators** 6 setpoint indicator LED's

**Digits** 2 rows of 6 digits, 10mm (0.4"), 14 segment alphanumeric LED

**Display range** 0.1 to 99999.9

## Construction

**Casing** Panel mount case

**Ingress protection rating** IP65 dust/splash proof (face only)

## Dimensions (H x W x D)

48 x 96 x 120mm (1.89 x 3.78 x 4.72")

**Panel cutout** 45 x 92mm (1.77 x 3.62")

## 2

## FRONT PANEL &amp; DISPLAY

## 2.1 - Front panel

● SPX The SP LED's are used to indicate active setpoints.

**F1** This button is used to access the **Input Setup & Calibration** menu (Section 5).

**P** This button is used to save your settings and advance to the next step in the setup process.

**▲** This button is typically used to scroll through options or increase values in the setup menu. Pressing this button from the main display will allow you to view/reset the *Peak* value (see 2.3).

**▼** This button is typically used to scroll through options or decrease values in the setup menu. Pressing this button from the main display will allow you to view/reset the *Valley* value (see 2.3).

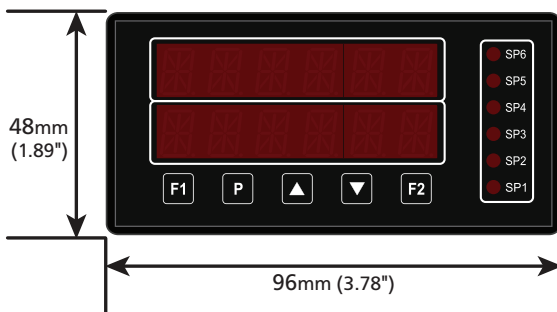

**F2** This button is used to access the **Setpoint Setup** menu (Section 6) and the **Setpoint Open Access** menu (Section 7).







## 2.2 - Display brightness

To adjust the display brightness, press the **P** and **▲** buttons together from the main display. **BRI** appears and toggles with the current setting. Use the **▲** and **▼** buttons to adjust the LED backlight, and then press **P** to finish.

## 2.3 - Up and down button shortcuts

Pressing the  and  buttons from the main operational display allows instant access to 'Peak' and 'Valley' values, which are held in the controller's memory.

- › **PEAK** is the maximum measured value since the instrument was turned on or reset, and this value can be viewed by pressing the  button from the operational display.
- › **VALLEY** is the minimum measured value since the instrument was turned on or reset, and this value can be viewed by pressing the  button from the operational display.
- › Press  at any time to return to normal operating mode.

'Peak' or 'Valley' can be reset to zero by pressing the  and  buttons **at the same time** while the desired variable is being displayed, or by using the input pins (3.6).

## 3

## WIRING

**BEFORE YOU BEGIN WIRING**, ensure that the unit is switched off and the power supply is disconnected.

### 3.1 - Pinouts

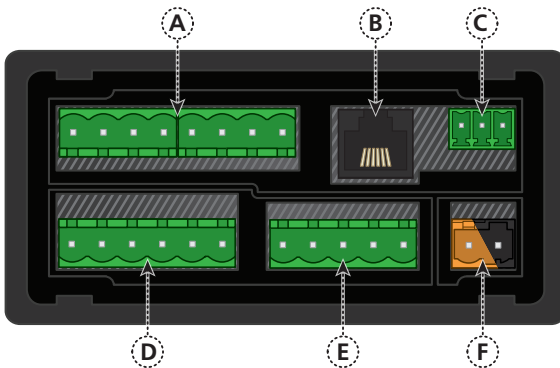

#### Key

**3.1A** Relay Output (See 3.4)

**3.1B** Serial Port (See 3.5)

**3.1C** Analog Output (See 3.3)

**3.1D** Analog Input (See 3.2)

**3.1E** Function Pins (See 3.6)

**3.1F** Power Supply HV/LV  
(See 3.7)

## 3.2 - Wire the analog input module

See 3.1D

Wire your analog input module, referring to the diagram (right).

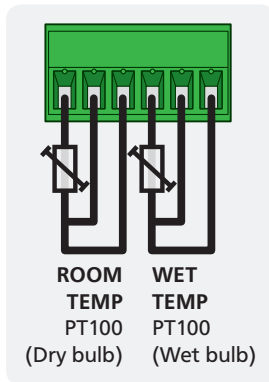

## 3.3 - Wire the analog output

See 3.1C

Wire your dual 4–20mA analog outputs as shown, if required for your application.



## 3.4 - Wire the relay outputs (if installed)

See 3.1A

If your controller has relay outputs fitted, wire them as shown below. Relays can be programmed to operate within the total span range of the controller.

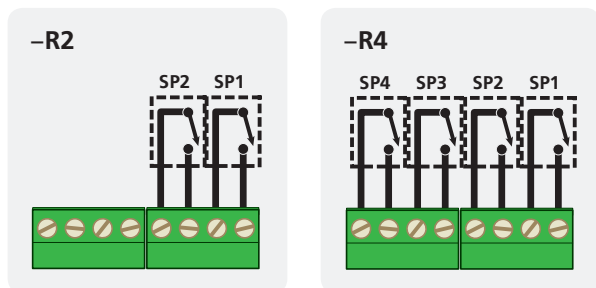

### 3.5 - Wire the serial port (if installed)

See 3.1B

If your controller has serial port fitted, wire it as shown in the applicable diagram.

- › S2R: RS232, RJ11 terminal
- › S4S: RS485, screw terminal

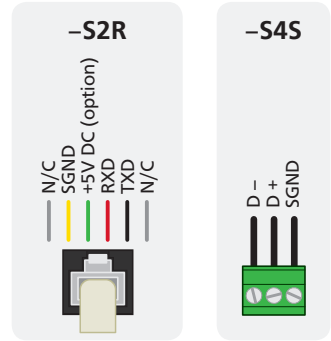

### 3.6 - Wire the function pins See 3.1E

Connect external switches as shown to enable a function to be executed when its switch is activated.

- › **Valley** Clears the Valley reading (also see 2.3)
- › **Hold** Holds the current display value
- › **Test** Resets the meter
- › **Peak** Clears the Peak reading (also see 2.3)

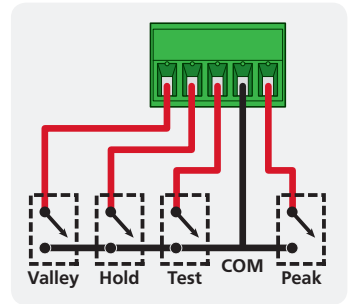

### 3.7 - Wire the power supply

See 3.1F

**DO NOT connect your low voltage controller to mains power.**

Wire the power supply as shown below. Compare the label on the unit with the connector:

- › **Orange** = HV (85–265V AC, 95–370V DC)
- › **Black** = LV (15–48V AC, 10–72V DC)

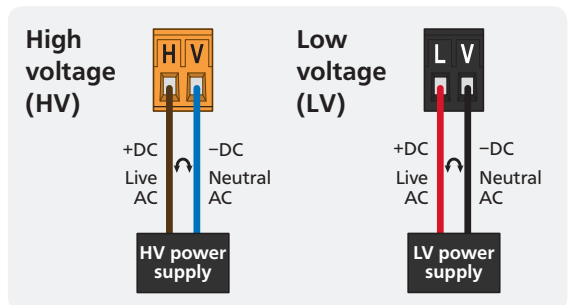

Once you have completed the wiring process it is safe to switch

on your power supply. Ensure that your display is functioning before you proceed.

## 4

## DIMENSIONS &amp; INSTALLATION

## 4.1 - Case dimensions

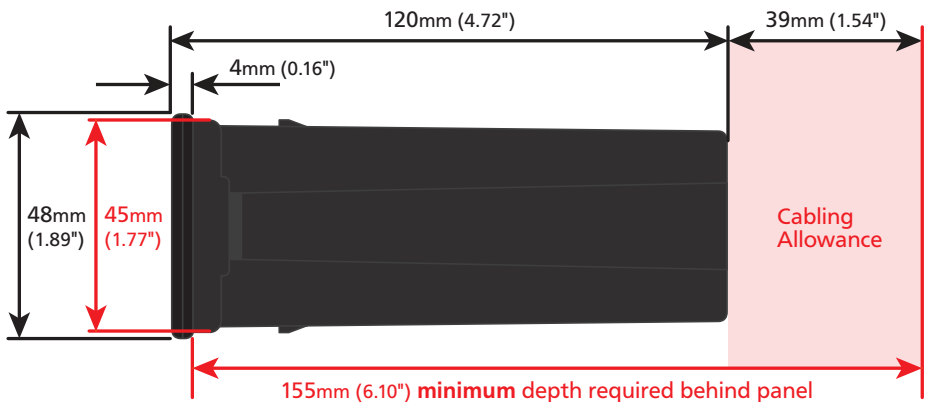
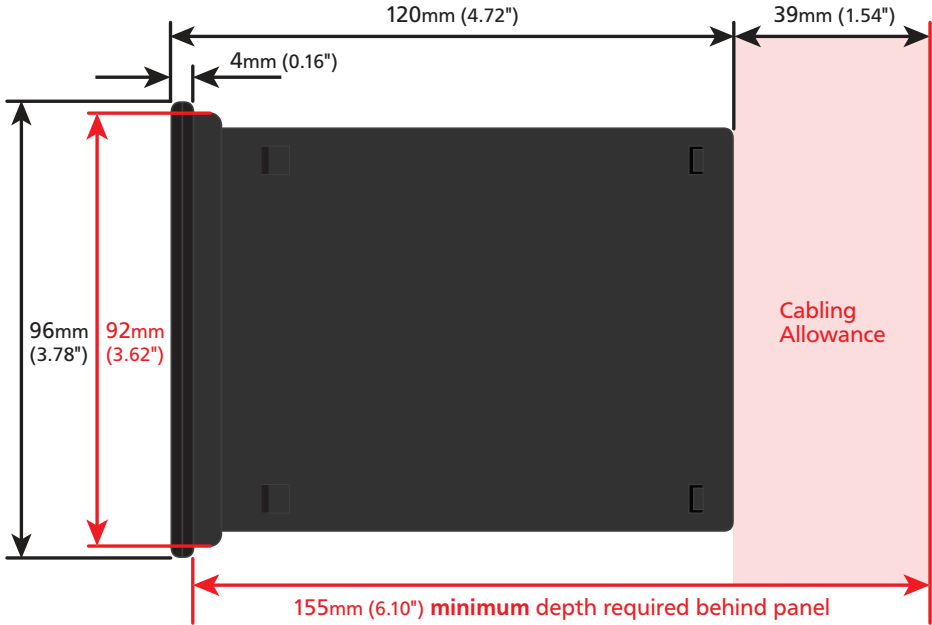

## 4.2 - Installation instructions

- A** Prepare the **Panel Cutout** to  $92 \times 45\text{mm} \pm 0.5$  ( $3.62 \times 1.77'' \pm 0.02$ ), as shown below.

**Allow at least 155mm (6.10") depth behind the panel to accommodate the meter body, protruding connectors and cabling.**

- B** Remove the **Mounting Clips** from the meter back.

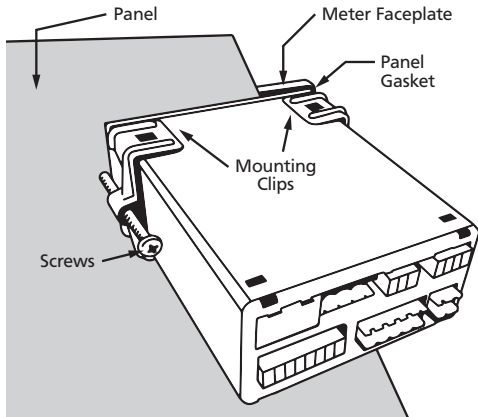

- C** Slide the **Panel Gasket** over the rear of the unit to the back of the **Meter Faceplate**.
- D** From the front of the panel, insert the meter into the **Panel Cutout**. Holding the unit in place, engage the **Mounting Clips** so that the tabs snap into place over the notches on the case.
- E** To achieve a proper seal, tighten the **Screws** evenly until the unit sits firmly against the panel. Do not over-tighten the screws.

Panel Cutout

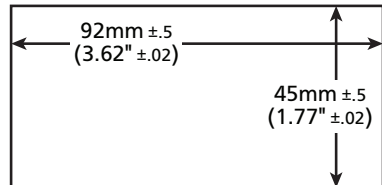



## 5

## INPUT SETUP &amp; CALIBRATION

---

## 5.1 - Enter Cal PIN number

A Enter the calibration mode by pressing the **F1** button.

**\_\_\_ ENTER CAL PIN NUMBER** scrolls across the bottom row, and **0** appears in the top row. Use the **↑** and **↓** buttons to enter your security code (factory default 1). Then press **P**. If the correct PIN is entered, setup is started at 5.2.

If an incorrect PIN number is entered, **\_\_\_ INCORRECT PIN NUMBER – ACCESS DENIED** scrolls across the display and it returns to normal operating mode.

---

You will have the opportunity to change your PIN number at the end of this section (5.7). If you have forgotten your PIN number, see Section 8.

---



## 5.2 - Input setup

A **\_\_\_ INPUT SETUP** scrolls across the bottom row, and **SKIP** appears in the top row. Press **P** to skip to 5.3, or the **↑** button and then **P** to **ENTER** input setup.

B **\_\_\_ MAINS FREQUENCY** scrolls across the bottom row, and the current selection appears in the top row. Use the **↑** and **↓** buttons to select **50HZ** or **60HZ**, and then press **P**.



C **\_\_\_ SENSOR TYPE** scrolls across the bottom row, and the currently selected sensor type appears in the top row. Use the **↑** and **↓** buttons to select either **RTD385** (default) or **RTD392**. Then press **P**.

D **\_\_\_ SELECT TEMPERATURE SCALE** scrolls across the bottom row, and the currently selected temperature units appear in the top row. Use the **↑** and **↓** buttons to select either **DEG C** (Celsius) or **DEG F** (Fahrenheit). Then press **P**.

**E** **\_\_\_ DISPLAY TEMPERATURE UNITS** scrolls across the bottom row, and the current selection appears in the top row. Use the  and  buttons to select either **YES** or **NO**, and then press .

If you select **YES**, then **C** or **F** (as selected in 5.2D) will appear after the last digit of the temperature value on the main display.

*Note that activating this feature will effectively limit your temperature display range to 5 digits (9999.9), because the last character is used for the units.*

**F** **\_\_\_ DISPLAY HUMIDITY UNITS** scrolls across the bottom row, and the current selection appears in the top row. Use the  and  buttons to select either **YES** or **NO**, and then press .

If you select **YES**, then the percent symbol (%) will appear after the last digit of the humidity value on the main display.





---

## 5.3 - Calibration

---

Your TEX-DEW200 is factory calibrated for 0–100°C (32–212°F). In many cases you will not need to calibrate again.

---

**A** **\_\_\_ CALIBRATE** scrolls across the bottom row, and **SKIP** appears in the top row. Press  now to skip to 5.4, or use the  and  buttons to select a channel to calibrate: **RH** (relative humidity), **RM TMP** (room temperature), or **WT TMP** (wet bulb temperature). Press  to continue.

- ➔ If you selected **RM TMP** or **WT TMP**, complete steps 5.3B–F now.
- ➔ If you selected **RH**, complete steps 5.3G–H now.
- ➔ If you selected **SKIP**, skip to 5.4 now.

---



### Temperature calibration

---

**B** **\_\_\_ APPLY LOW INPUT AND WAIT FOR STABLE READING** scrolls across the bottom row, and the current input signal appears in the top row. Apply the low input signal and wait for the reading to stabilise. Then press .



*If averaging has been applied to the selected channel (see 5.4), it may take 20–30 seconds or longer for the reading to stabilise.*

---

**C** **\_\_\_ ENTER LOW DISPLAY VALUE** scrolls across the bottom row, and the currently selected low display value appears in the top row. Use the  and  buttons to adjust the display value for the low level input signal as required, and then press .

**D** **\_\_\_ APPLY HIGH INPUT AND WAIT FOR STABLE READING** scrolls across the bottom row, and the current input signal appears in the top row. Apply the high input signal and wait for the reading to stabilise. Then press .

*If averaging has been applied to the selected channel (see 5.4), it may take 20–30 seconds or longer for the reading to stabilise.*

**E** **\_\_\_ ENTER HIGH DISPLAY VALUE** scrolls across the bottom row, and the currently selected high display value appears in the top row. Use the  and  buttons to adjust the display value for the high level input signal as required, and then press .



**F** If calibration was successful, the controller will exit the menu and resume normal operation, without showing any other scrolling messages. (To enter step 5.4, you *must* select **SKIP** at 5.3A.)

If calibration fails, **\_\_\_ CALIBRATION FAILED** will scroll across the display and you will be directed back to the operational display. The most likely cause of this error is that the controller was unable to detect any change in input signal during the calibration process. Check your signal and connections, and try again.

---

## Humidity offset

---

**G** **\_\_\_ ENTER HUMIDITY OFFSET CORRECTION** scrolls across the bottom row, and the current offset value appears in the top row. This value can be set from **-20%** to **+20%**, to manually adjust the humidity display. Use the  and  buttons to adjust, if required, and then press .

**H** The controller will exit the calibration menu and resume normal operation. (To enter step 5.4, you *must* select **SKIP** at 5.3A.)

## 5.4 - Averaging

Your controller has input signal averaging, optimising stable measurement.

If the change in input exceeds the averaging window value it will not average, ensuring fast response when there are large differences between readings.

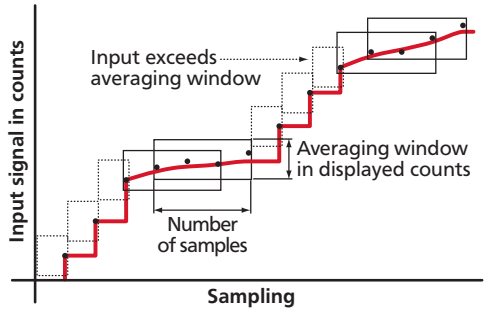

**A** **\_\_\_ AVERAGING SETUP** scrolls across the bottom row, and **SKIP** appears in the top row. Press **[P]** to skip to 5.5, or use the **[↑]** and **[↓]** buttons to select a channel to configure: **RH** (relative humidity), **RM TMP** (room temperature), or **WT TMP** (wet bulb temperature). Press **[P]** to continue.

**B** **\_\_\_ AVE SAMPLES** scrolls across the bottom row, and the current selection appears in the top row. Using the **[↑]** and **[↓]** buttons, alter the number of input samples that the controller will average for the selected channel. Then press **[P]**.

*Increasing the number of samples will stabilise measurement, but it will also slow down response rates. A typical value is 4.*

**C** **\_\_\_ AVE WINDOW** scrolls across the bottom row, and the currently selected averaging window value appears in the top row. Using the **[↑]** and **[↓]** buttons, alter the signal averaging window for the selected channel. Then press **[P]**.

*If your input signal contains large noise spikes, you can increase the size of the averaging window to ensure that these are still averaged. However, increasing the window size too far will reduce the ability of the controller to respond quickly to real changes in input signal. Setting **AVE WINDOW** to 0 will give continuous averaging as per the selected averaging samples. A typical value is 10% of your system capacity.*

**D** **\_\_\_ AVERAGING SETUP** scrolls across the bottom row, and **SKIP** appears in the top row. You are now back at 5.4A. Press **[P]** now to skip to 5.5, or repeat 5.4A–D to configure averaging for a different channel.

## 5.5 - Analog output setup

*N.B. All new units are calibrated before shipping. Recalibration is **only** necessary if settings are wiped or the unit's accuracy requires verification after a long period of use. e.g. 1 year.*

- A** \_\_\_ **ANALOGUE O/P SETUP** scrolls across the bottom row, and **SKIP** appears in the top row. Press **P** to skip to 5.6, or use the **↑** and **↓** buttons to select an analog output channel to configure: either **RH** (relative humidity), or **RM TMP** (room temperature). Press **P** to continue.
- B** \_\_\_ **LOW SCALE VALUE FOR ANALOGUE O/P** scrolls across the bottom row, and the currently selected low scale display value appears in the top row. Use the **↑** and **↓** buttons to enter your cal low position, and then press **P**.
- C** \_\_\_ **HIGH SCALE VALUE FOR ANALOGUE O/P** scrolls across the display and toggles with a calibration number shown in internal units (around 30000). Press the **↑** or **↓** buttons, until the multimeter displays your target high output, then press **P**.
- D** \_\_\_ **CALIBRATE ANALOGUE O/P?** scrolls across the bottom row, and **SKIP** appears in the top row. Use the **↑** and **↓** buttons to select **SKIP** or **ENTER**, and then press **P**. **You should not need to calibrate your output (see top)**
- ➔ If you selected **SKIP**, skip to 5.5G now.
  - ➔ If you selected **ENTER**, connect a mA meter across the analog output connector (see 3.3), and then continue to 5.5E.
- E** \_\_\_ **CAL LOW ANALOGUE O/P** scrolls across the display and toggles with a calibration number shown in internal units (around -16000). Press the **↑** or **↓** buttons until the multimeter displays your target low output (e.g. 4mA), then press **P**.
- F** \_\_\_ **CAL HIGH ANALOGUE OUTPUT** scrolls across the display and toggles with a calibration number shown in internal units (around 30000). Press the **↑** or **↓** buttons, until the multimeter displays your target high output, then press **P**.
- G** \_\_\_ **ANALOGUE O/P SETUP** scrolls across the bottom row, and **SKIP** appears in the top row. You are now back at 5.5A. Press **P** now to skip to 5.6, or repeat 5.5A–G to set up another analog output channel.

---

## 5.6 - Serial setup

**A** \_\_\_ **SERIAL SETUP** scrolls across the bottom row, and **SKIP** appears in the top row. If your controller does not have a serial port installed, (or you do not wish to configure your serial options now), please press **P** to skip to 5.7.

Otherwise, press the **↑** button and then **P** to **ENTER** serial setup.

**B** \_\_\_ **SERIAL MODE** scrolls across the bottom row, and the current serial mode appears in the top row. Use the **↑** and **↓** buttons to choose between: **ASCII** (custom), **MODBUS (RTU)**, or **RNGR A (Ranger A)**. Then press **P**.

*ASCII is a simple custom protocol that allows connection to various PC configuration tools.*

*MODBUS is an industry standard RTU slave mode that allows connection to a wide range of devices, such as PC's or PLC's.*

*RNGR A is a continuous output, used to drive remote displays and other instruments in the Rinstrum™ range. (Ranger is a trade name belonging to Rinstrum Pty Ltd.)*

*See Appendix A for more information about the available serial modes.*

**C** \_\_\_ **BAUD RATE** scrolls across the bottom row, and the current selection appears in the top row. Use the **↑** and **↓** buttons to select one of: **300, 600, 1200, 2400, 4800, 9600, 19200** or **38400**. Then press **P**.

**D** \_\_\_ **PARITY** scrolls across the bottom row, and the currently selected parity appears in the top row. Using the **↑** and **↓** buttons, select: **NONE, ODD** or **EVEN**, and then press **P**.

**E** \_\_\_ **SERIAL ADDRESS** scrolls across the bottom row, and the currently selected serial address appears in the top row. Use the **↑** and **↓** buttons to alter the serial address, and then press **P**.

*The serial address parameter is used to identify a particular device when it is used with other devices in a system. (It applies particularly to MODBUS mode when used on an RS485 serial network.) The serial address of the controller must be set to match the serial address defined in the master device.*

---

Refer to Appendix A for more information on serial modes and registers.

---

---

## 5.7 - Edit Cal PIN number

- A** **\_\_\_ EDIT CAL PIN NUMBER** scrolls across the bottom row, and **SKIP** appears in the top row. Press **P** to skip and return to the operational display, or the **↑** button and then **P** to **ENTER** and change your PIN number.
- B** **\_\_\_ ENTER NEW CAL PIN** scrolls across the bottom row, and the current PIN (default 1) appears in the top row. Using the **↑** and **↓** buttons, enter your new Cal PIN number. Then press **P** to save and exit to the operational display.

## 6

## SETPOINT SETUP

## 6.1 - Enter SP PIN number

- A Enter setpoint setup mode by pressing and holding the **F2** button for 3 seconds. **\_\_ \_ ENTER SP PIN NUMBER** scrolls across the bottom row, and **0** appears in the top row. Use the **↑** and **↓** buttons to enter your security code (factory default 1). Then press **P**. If the correct PIN is entered, setup is started at 6.3.
- If an incorrect PIN number is entered, **\_\_ \_ \_ INCORRECT PIN NUMBER – ACCESS DENIED** scrolls across the display and it returns to normal operating mode.

You will have the opportunity to change your PIN number at the end of this section (6.3). If you have forgotten your PIN number, see Section 8.

## 6.2 - Setpoint setup



The software in your controller will allow you to configure up to 4 setpoints, however full functionality is only supported when relay output hardware installed. (Setpoints with no corresponding relay output hardware may be used as simple LED indicators, if desired. In this case, features requiring relay output functionality will continue to appear in the setup menu, but will be ignored by the controller.)



- A **\_\_ \_ EDIT SETPOINT** scrolls across the bottom row, and **SKIP** appears in the top row. Press **P** now to skip to 6.3, or use the **↑** and **↓** buttons to select a setpoint to edit, and then press **P**.
- B **\_\_ \_ SP VALUE** scrolls across the bottom row, and the current value for the selected setpoint appears in the top row. Using the **↑** and **↓** buttons, adjust the display value at which the selected setpoint will activate, and then press **P**.

*The units for the SP VALUE will always correspond with your chosen SP SOURCE.*



*I.e. If you select 50.0% as your SP VALUE in this step, and then you choose RM TEMP as your SP SOURCE in 6.2C, your SP VALUE will be automatically changed to 50.0°C/F.*



**C** \_\_\_ **SP SOURCE** scrolls across the bottom row, and the current selection appears in the top row. Use the  and  buttons to select **RH** (relative humidity) or **RM TMP** (room temperature), and then press .

**D** \_\_\_ **SP ACTIVATION** scrolls across the bottom row, and the activation for the selected setpoint appears in the top row. Using the  and  buttons, set the relay activation to operate **ABOVE** or **BELOW** the setpoint value, and press .

***ABOVE:** Relay turns on above the setpoint value and off below it. **BELOW:** Relay turns on below the setpoint value and off above it.*

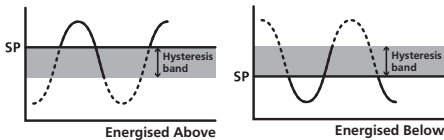

**E** \_\_\_ **SP TYPE** scrolls across the bottom row, and the current type for the selected setpoint appears in the top row. Using the  and  buttons, select either **ALARM** or **CNTRL** (control), and then press .

***ALARM - SP VALUE** controls setpoint activation point. **HYSTERESIS VALUE** controls setpoint deactivation point.*



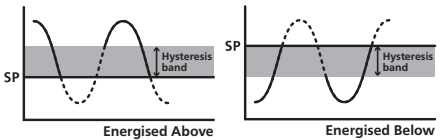





***CNTRL - SP VALUE** controls setpoint deactivation point. **HYSTERESIS VALUE** controls setpoint reactivation point.*



**F** \_\_\_ **HYSTERESIS VALUE** scrolls across the bottom row, and the hysteresis value for the selected setpoint appears in the top row. Use the  and  buttons to adjust this value if required, and then press .

*The **HYSTERESIS VALUE** defines the separation band between setpoint activation and deactivation, and will operate as per the **SP TYPE** setting selected in 6.2E.*

**G** \_\_\_ **MAKE DELAY** scrolls across the bottom row, and the make delay time for the selected setpoint appears in the top row. This is the time delay between setpoint activation, and when the relay turns on. Adjust this value in 0.1 second increments using the  and  buttons, and then press .

**H** \_\_\_ **OPEN ACCESS TO SP VALUE** scrolls across the bottom row, and the open access permission setting for the selected setpoint appears in the top row. Use the  and  to select either **OFF** or **ON**, and then press .

*When enabled, this option allows the selected setpoint's value to be edited directly after pressing the  button, without needing to enter a PIN number or go through all of the other options. Each setpoint can individually have this option enabled or disabled. See Section 7.*

- I \_\_\_ **EDIT SETPOINT** scrolls across the bottom row, and **SKIP** appears in the top row. You are now back at 6.2A. Press **P** now to skip to 6.3, or repeat 6.2A–I to set up another setpoint.

---

### 6.3 - Edit SP PIN number

- A \_\_\_ **EDIT SP PIN NUMBER** scrolls across the bottom row, and **SKIP** appears in the top row. Press **P** to skip and return to the operational display, or the **↑** button and then **P** to **ENTER** and change your PIN number.
- B \_\_\_ **ENTER NEW SP PIN** scrolls across the bottom row, and the current PIN (default 1) appears in the top row. Using the **↑** and **↓** buttons, enter your new SP PIN number. Then press **P** to save and exit to the operational display.

## 7

### SETPOINT OPEN ACCESS

---

If none of the setpoints have their open access option enabled then this feature will be disabled and the **F2** button will not respond to a short button press. (See 6.2H.)



- A Begin by pressing the **F2** button for less than 3 seconds.
- B The name of the first access-enabled setpoint will appear on the display and toggle with the current value for that setpoint. Using the **↑** and **↓** buttons, adjust the selected value. Then press **P** to accept and continue.
- C The name of the next access-enabled setpoint will appear on the display, along with its setpoint value. Repeat step 7B. The direct access menu will proceed through all access-enabled setpoints in this fashion. Pressing **P** for the last enabled setpoint will exit and return to the operational display.

## 8

## RESET PIN NUMBERS / VIEW FIRMWARE VERSION

If you have forgotten your PIN number(s), follow the procedure below to reset both the Cal and SP PINs to their factory default of 1.

This procedure will also allow you to view the current software installed on your controller, which may be required for support purposes.

- A Press ,  and  at the same time. (This key combination can be difficult to execute and you may need several tries to get it right.)
- B A message will appear on the display, with details of the unit's current software configuration (Product Name, Firmware Version, and Macro Version). At the end, you will see – **ALL PIN NUMBERS RESET TO 1**.
- C Both the Cal PIN number and the SP PIN number have now been reset to '1'. You can change this, if required, by following the instructions in 5.7 (for the *Input Setup & Calibration* menu) and 6.3 (for the *Setpoint Setup* menu), using '1' to enter each menu initially.

## A.1 - Custom ASCII mode

Custom ASCII is a simple, custom protocol that allows connection to various PC configuration tools. ('Custom ASCII' differs from the 'Modbus (ASCII)' protocol used by some devices.) Custom ASCII command strings must be constructed in this order:

**<Start> <Controller Address> <Read/Write Command> <Register Address>  
<Separator Character> <Data Value> <Message Terminator>**

**Start** - Use 'S' for the start character of a command string (not case sensitive). This must be the first character in the string.

**Controller Address** - Use an ASCII number from '1' to '255' for the controller address. If the character following the start character is not an ASCII number, then address '0' is assumed. All controllers respond to address '0'.

**Read/Write Command** - Use ASCII 'R' for read, 'U' for unformatted read, or 'W' for write (not case sensitive). Any other character aborts the operation.

*In Custom ASCII mode, data is normally read as formatted data (which includes decimals and any text characters that may be selected to show units). However it is also possible to read unformatted data by using a 'U' in the read command. There is no unformatted write command, as when writing to fixed point registers, any decimal point and text characters are ignored.*

**Register Address** - The register address for the read/write operation will be an ASCII number from '1' to '65535'. This character must be specified for a write command, but may be omitted for a read command, (in which case the controller will respond with the data value currently on the display).

**Separator Character** - The separator character can be either a space or a comma, and is used to separate the register address from the data value.

**Data Value** - Must be an ASCII number. The absolute limits for this number are -1000000 to +1000000, but note that not all registers will accept this range.

**Message Terminator** - This is the last character, and must be either a '\$' (dollar) or an '\*' (asterisk). Neither of these characters should be used elsewhere in the message string. If '\$' is used, a 50ms minimum delay is inserted before a reply is sent. If '\*' is used, a 2ms minimum delay is inserted before a reply is sent.

---

 Custom ASCII Read/Write Examples

Example	Description
<b>S15R\$</b>	Read display value from controller address 15, 50ms delay.
<b>S3U40*</b>	Read unformatted data in channel 4 from controller address 3, 2ms delay.
<b>S2W2 -10000\$</b>	Write -10000 to the display register of controller address 2, 50ms delay.
<b>SWT CHAN_1\$</b>	Write ASCII text string Chan_1 to channel 1 text register, 50ms delay.

---

 Custom ASCII Registers - *Active for models with relay output installed*

---

## 16 Bit Unsigned

Address	Function
<b>1</b>	Alarm status (SP1=Bit 0, SP2=Bit 1, SP3=Bit 2, SP4=Bit 3)
<b>65-68</b>	Hysteresis (SP1=65, SP2=66, SP3=67, SP4=68)
<b>71-74</b>	Make delay (SP1=71, SP2=72, SP3=73, SP4=74)

## 32 Bit Signed

Address	Function
<b>16</b>	Room temperature
<b>250</b>	Wet bulb temperature
<b>254</b>	Humidity display
<b>6-9</b>	Setpoint 1-4 (SP1=6, SP2=7, SP3=8, SP4=9)
<b>12</b>	Peak
<b>13</b>	Valley
<b>34</b>	D/A 1 scale low value (humidity)
<b>35</b>	D/A 2 scale low value (room temp)
<b>36</b>	D/A 1 scale high value (humidity)
<b>37</b>	D/A 2 scale high value (room temp)

---

**Controller Response** - After the controller has completed a read or write instruction, it responds by sending a carriage return/line feed (CR/LF) back to the host.

If the instruction was a read command, the CR/LF follows the last character in the ASCII string.

If it was a write command, CR/LF is the only response sent back. The host must wait for this before sending further commands to the controller.

If the controller encounters an error, it will respond with a null (0x00) CR/LF.

## A.2 - Modbus (RTU) mode

Modbus (RTU) is an industry standard RTU slave mode that allows connection to a wide range of devices. Modbus registers are all holding registers, and should be accessed via function codes 3 and 6.

Register addresses are displayed in the Modicon™ 5-digit addressing format. I.e. Register 65=40065 (subtract 1 for direct addressing).

### Modbus (RTU) Registers - *Active for models with relay output installed*

#### 16 Bit Unsigned

Address	Function
<b>40001</b>	Alarm status (SP1=Bit 0, SP2=Bit 1, SP3=Bit 2, SP4=Bit 3)
<b>40065– 40068</b>	Hysteresis (SP1=40065, SP2=40066, SP3=40067, SP4=40068)
<b>40071– 40074</b>	Make delay (SP1=40071, SP2=40072, SP3=40073, SP4=40074)

#### 32 Bit Signed (2 x 16 Bit)

LSW	MSW	Function
<b>40529</b>	40530	Room temperature
<b>40523</b>	40524	Wet bulb temperature
<b>40515</b>	40516	Humidity display
<b>40525</b>	40526	Peak
<b>40527</b>	40528	Valley
<b>40535 –541</b>	<b>40536 –542</b>	Setpoint 1–4 (SP1=40535, SP2=40537, SP3=40539, SP4=40541)
<b>40587</b>	40588	D/A 1 scale low value (humidity)
<b>40589</b>	40590	D/A 2 scale low value (room temp)
<b>40591</b>	40592	D/A 1 scale high value (humidity)
<b>40593</b>	40594	D/A 2 scale high value (room temp)

---

## A.3 - Ranger A mode

Ranger A is a continuous output, used to drive remote displays and other instruments in the Rinstrum™ range. (Ranger is a trade name belonging to Rinstrum Pty Ltd.) Ranger A output strings are constructed as shown:

**<Start> <Sign> <Output Value> <Status> <End>**

**Start** - STX character (ASCII 02)

**Sign** - Output value sign (space for + and dash for -)

**Output Value** - Seven character ASCII string containing the current output value and decimal point. (If there is no decimal point, then the first character is a space. Leading zero blanking applies.)

**Status** - Single character output value status. 'U'=Under, 'O'=Over, 'E'=Error.

**End** - ETX character (ASCII 03)



---

## Define Instruments

### New Zealand (Head Office)

 10B Vega Place, Rosedale,  
Auckland 0632, New Zealand  
PO Box 245 Westpark Village,  
Auckland 0661, New Zealand

Ph: +64 (9) 835 1550

Fax: +64 (9) 835 1250

 [sales@defineinstruments.co.nz](mailto:sales@defineinstruments.co.nz)

[www.defineinstruments.co.nz](http://www.defineinstruments.co.nz)

### United States (Dallas, TX)

Ph: (214) 926 4950

 [sales@defineinstruments.com](mailto:sales@defineinstruments.com)

[www.defineinstruments.com](http://www.defineinstruments.com)

---