



The TEX-CTR10 indicator is the ideal solution for a variety of counting and rate application requirements.

This meter has been designed for ease of use, with intuitive, scrolling text prompts that guide you step-by-step through the setup process.

The front panel includes a 6 digit LED display and five front panel buttons, for simple operator interface.

One of the five buttons is user-programmable, so you can customise it as a shortcut to your most frequently used feature.

## Order Codes

### TEX-CTR10

-HV 85-265V AC / 95-370V DC

-LV 15-48V AC / 10-72V DC

#### Options

-A 1 x mA/V analog output

-S2R 1 x RS232 (RJ11 terminal)

-S4S 1 x RS485 (screw terminal)

## Contents

<b>1 - Specifications</b> .....	2
<b>2 - Front Panel &amp; Display</b> .....	3
<b>3 - Wiring</b> .....	4
<b>4 - Dimensions &amp; Installation</b> .....	8
<b>5 - Input Header Adjustment</b> .....	10
<b>6 - Input Setup &amp; Calibration</b> .....	12
<b>7 - Reset PIN Number /</b>	
<b>View Firmware Vsn</b> .....	18
<b>A - Appendix A - Serial Modes</b> .....	19

## 1

## SPECIFICATIONS

## Input

**Sensor input** NPN, PNP, TTL, namur, ta-cho or closed contact

**Input** 0-24V DC, 0-30V AC

**Power supply**

HV: 85-265V AC/95-370V DC, or

LV: 15-48V AC/10-72V DC

**Excitation** 24V DC (50mA max)

**Sampling rate**

Rate: 100msec, Counter: 10msec

**Resolution** Rate: 0.01Hz (1Hz in high-speed mode)

**Accuracy** 0.005% of reading

**Ambient drift** 2ppm/°C typical

**Noise filtering** 0.2kHz, 2kHz, 20kHz or off

**Pulse width** Must be >5 $\mu$ s

**Input frequency**

Rate: 10kHz max (100kHz in high-speed mode), Counter: 100kHz max

## Analog Output

**OPTIONAL**

**Number of analog outputs** None or 1

**Analog output type** Isolated 16 bit 4–20mA/0–10V

## Comm Port

**OPTIONAL**

**Number of comm ports** None or 1

**Comm port options**

S2R= Isolated RS232, RJ terminal, or

S4S= Isolated RS485, screw terminal

## Programming

**Front panel buttons** Up, Down, P (Prog/Enter), plus 2x Function Buttons for menu access & custom function

**Security** Input and setpoint setups are independently PIN protected

## Display

**Display type** LED display, 5 buttons

**Digits** 1 row of 6 digits, 13mm (0.5") size, 14-segment alphanumeric LED

## Construction

**Casing** Panel mount case, 5 buttons

**Ingress protection rating** IP65 dust/splash proof (face only)

**Dimensions (H x W x D)**

48 x 96 x 120mm (1.89 x 3.78 x 4.72")

**Panel cutout** 45 x 92mm (1.77 x 3.62")

## 2

## FRONT PANEL &amp; DISPLAY

## 2.1 - Front panel

**SPX** The SP LED's are not active for this model.

**F1** This button is used to access the **Input Setup & Calibration** menu (Section 6).

**P** This button is used to save your settings and advance to the next step in the setup process. Pressing this button from the operational display will hold the current display value (totalizer and rate values continue running in the background).

**↑** This button is typically used to scroll through options or increase values in the setup menu. Pressing this button from the main display will show the current rate value (see 2.3).

**↓** This button is typically used to scroll through options or decrease values in the setup menu. Pressing this button from the main display will show the current totalizer value (see 2.3).

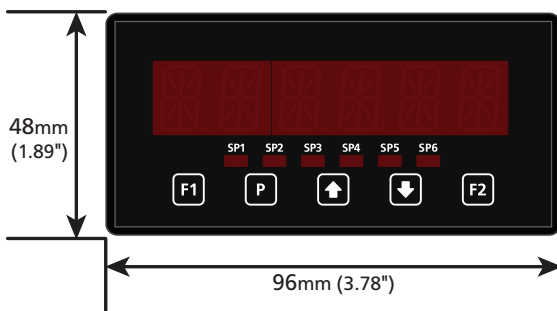

**F2** The function of a single keypress of this button from the operational display can be user programmed. By default, no function is assigned - see 6.5B to enable.





## 2.2 - Display brightness

To adjust the display brightness, press the **P** and **↑** buttons together from the main display. **BRI** appears and toggles with the current setting. Use the **↑** and **↓** buttons to adjust the LED backlight, and then press **P** to return to the normal operating mode.

## 2.3 - Up and down button shortcuts

A single keypress of either the  or  button from the operational display allows instant access to several values which are held in the controller's memory:

-  Shortcuts to the rate value ('RATE').
-  Shortcuts to the totalizer value ('TOTAL').

Press  at any time to return to normal operating mode.

## 3 WIRING

BEFORE YOU BEGIN WIRING, ensure that the unit is switched off and the power supply is disconnected.

### 3.1 - Pinouts

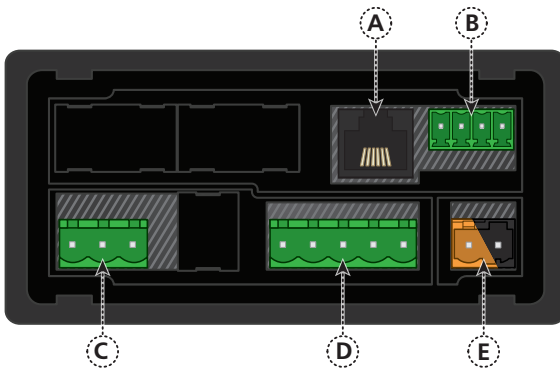

#### Key

- 3.1A Serial Port (See 3.4)
- 3.1B Analog Output (See 3.3)
- 3.1C Analog Input (See 3.2)
- 3.1D Function Pins (See 3.5)
- 3.1E Power Supply HV/LV (See 3.6)

### 3.2 - Wire the analog input

See 3.1C

**IMPORTANT:** The input module for this unit has four headers which are factory configured to suit your application. The unit is configured for an NPN type sensor by default.

- ➔ If you are using an **NPN** type sensor, you don't need to change anything.
- ➔ If you are using **PNP**, **TTL**, **Namur**, **Tacho**, or a **Pushbutton switch**, please review your header configuration before continuing, referring to Section 5.

Then wire your input as required, referring to the diagrams below.

### NPN open collector output with proximity switch

- › Active sensor signal: 0V
- › Inactive sensor signal: +24V

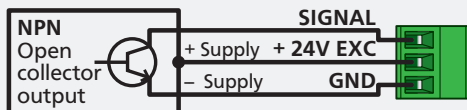

### PNP open collector output with proximity switch

- › Active sensor signal: +24V
- › Inactive sensor signal: 0V

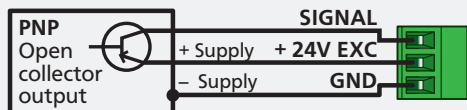

### Pushbutton switch

- › Open signal: +24V
- › Closed signal: 0V



### Tacho generator sensor

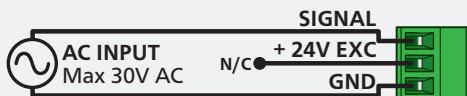

### TTL input

- › In this example the TTL logic has a separate +5V power supply

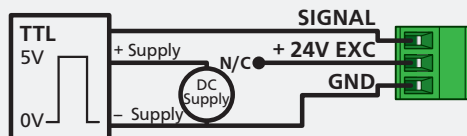

### Namur sensor

- › Active sensor signal: 0.3-1.0mA
- › Inactive sensor signal: 1.7 - 3.0mA

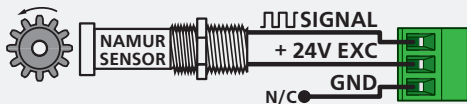

### 3.3 - Wire the analog output (if installed)

See 3.1B

If your controller has analog output fitted, wire it as shown for either current (4–20mA) or voltage (0–10V).

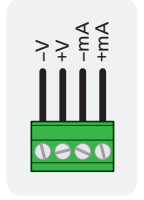

### 3.4 - Wire the serial port (if installed)

See 3.1A

If your controller has a serial port fitted, wire it as shown in the applicable diagram.

- › **S2R** RS232, RJ11 terminal
- › **S4S** RS485, screw terminal

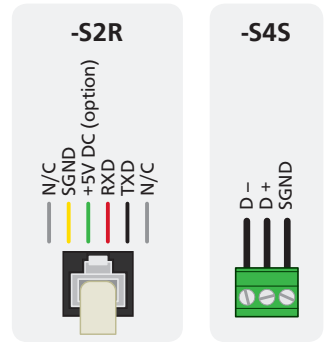

### 3.5 - Wire the function pins

See 3.1D

Connect external switches to enable a function to be executed when its switch is activated.

- › **User 1** User defined function (see 6.5C)
- › **Inhibit** Prevents the totalizer from counting
- › **Test** Resets the unit
- › **User 2** User defined function (see 6.5D)

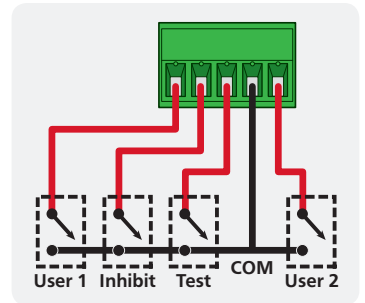

## 3.6 - Wire the power supply

See 3.1E

NEVER connect your low voltage controller to mains power.

Wire your controller for low or high voltage power supply, as show in the diagrams below. Check the label on the unit against the colour of the connector:

- › **Orange =**  
High voltage (85-265V AC,  
95-370V DC)
- › **Black =**  
Low voltage (15-48V AC,  
10-72V DC)

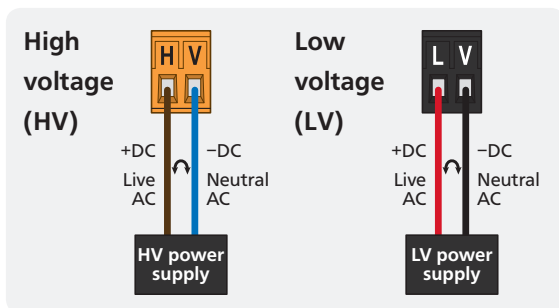

Once you have completed the wiring process it is safe to switch on your power supply. Ensure that your display is functioning before you proceed.

## 4

## DIMENSIONS &amp; INSTALLATION

## 4.1 - Case dimensions

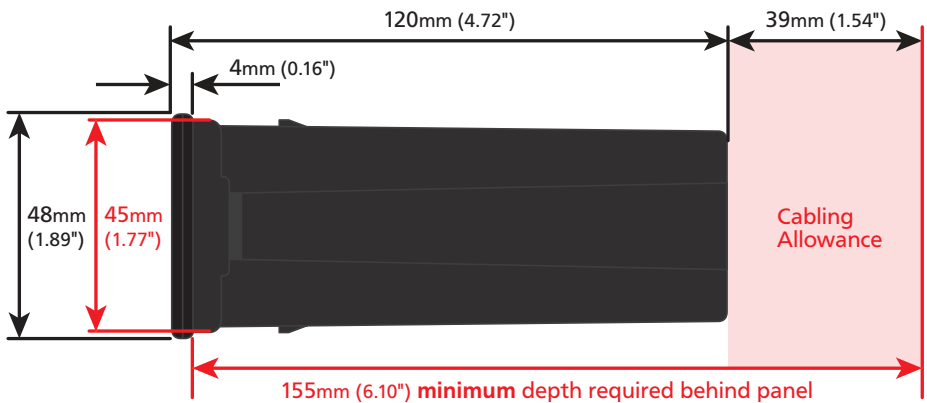
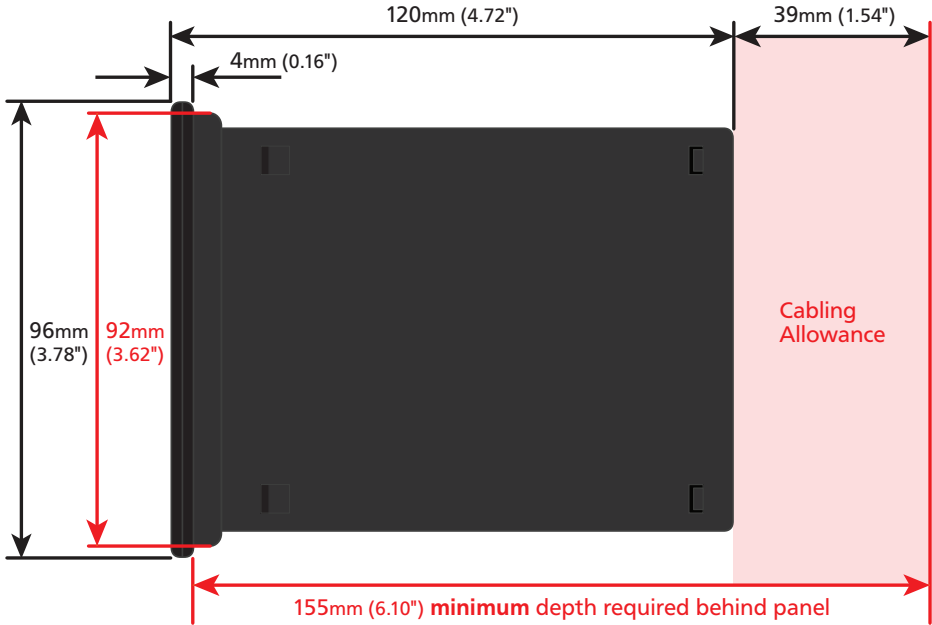



## 4.2 - Installation instructions

- A** Prepare the **Panel Cutout** to  $92 \times 45\text{mm} \pm 0.5$  ( $3.62 \times 1.77" \pm 0.02$ ), as shown below.  
**Allow at least 155mm (6.10") depth behind the panel to accommodate the meter body, protruding connectors and cabling.**
- B** Remove the **Mounting Clips** from the meter back.
- C** Slide the **Panel Gasket** over the rear of the unit to the back of the **Meter Faceplate**.
- D** From the front of the panel, insert the meter into the **Panel Cutout**. Holding the unit in place, engage the **Mounting Clips** so that the tabs snap into place over the notches on the case.
- E** To achieve a proper seal, tighten the **Screws** evenly until the unit sits firmly against the panel. Do not over-tighten the screws.

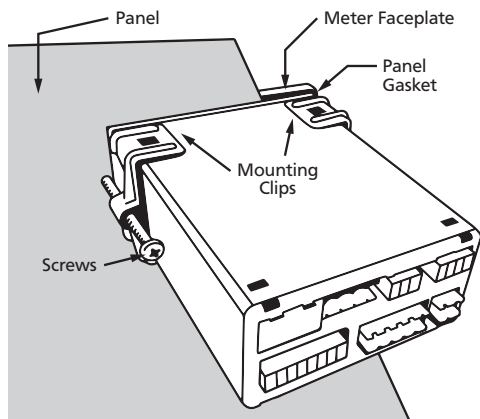

Panel Cutout

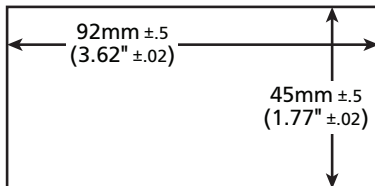

## 5

## INPUT HEADER ADJUSTMENT

## 5.1 - Input header settings

The analog input board for the TEX-CTR10 has four headers which affect the Low Pass Filter (A), Mode (B), Input Signal (C) and Load (D). Of these, headers A, C and D should be adjusted as required for your sensor type. (Header B should always be set to 'Counter').

Refer to the tables below to determine whether the default header positions (highlighted black) are suitable for your application.

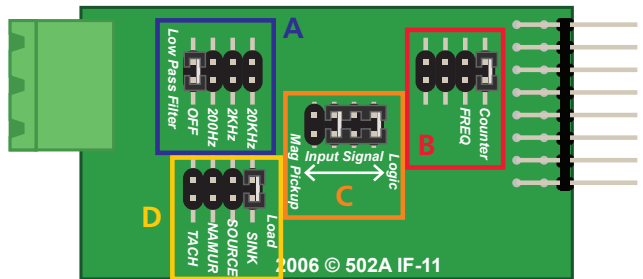

If required, follow the instructions in 5.2 to remove the analog input board from the meter case and adjust the header positions as needed.

## Low Pass Filter Header (A)

<b>OFF</b>	Ideal for high-speed counting
<b>200Hz</b>	Ideal for mechanical contacts
<b>2KHz</b>	Suitable for a noisy signal
<b>20KHz</b>	Suitable for a noisy signal

## Mode Header (B) - Do not adjust!

<b>Counter</b>	Always use this setting
<b>FREQ</b>	Not used for TEX-CTR10

## Input Signal Header (C)

<b>Logic</b>	NPN, PNP, Namur, TTL & Pushbuttons
<b>Mag Pickup</b>	Tacho

## Load Header (D)

<b>SINK</b>	NPN, TTL & Pushbuttons
<b>SOURCE</b>	PNP
<b>NAMUR</b>	Namur
<b>TACH</b>	Tacho

## 5.2 - How to remove the input module

**A** If the meter is already installed, remove it from the panel, and unplug all plugs from the back of the unit.

**B** Using a small screwdriver or similar implement, press downward into one of the slots at the rear of the case. This will disengage one of the tabs which holds the back plate on, allowing it to be gently levered away at one corner.

**C** Holding the loosened corner open with one hand, disengage the lever on the opposite slot (Fig 1).

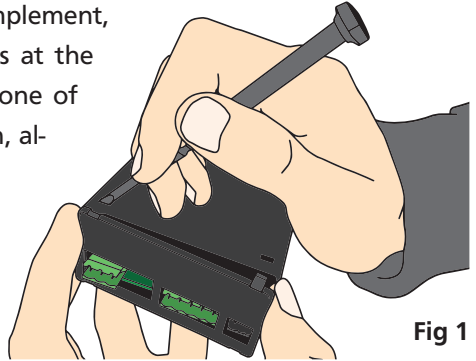

**Fig 1**

**D** You should now be able to remove the back plate. If it does not unclip easily, you may need to disengage the two remaining tabs by repeating steps 5.2B–C on the other side of the meter.

**E** Slide the analog input module out of the meter case (Fig 2). (See 3.1A to identify the input module.)

**F** Position the headers on the input module as required for your sensor type, referring to 5.1.

**G** Slide the input module back into the meter case.

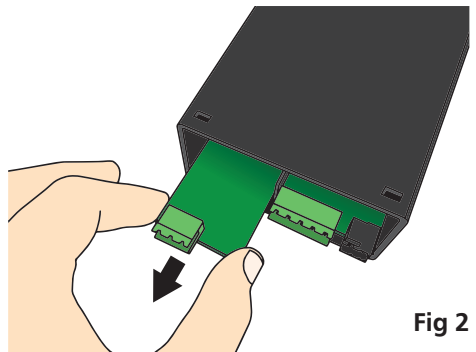

**Fig 2**

*Make sure that it is sitting in the tracks on the left and right. Press firmly until the input module is fully inserted and sits flush with the other boards that are visible from the back of the meter.*

**H** Replace the back plate.

*Begin by inserting the two lower tabs into the slots, and then position the upper tabs so that they will not catch on the top lip of the meter case. Apply firm pressure until the back plate clicks into place.*

**I** Reconnect the plugs and return the meter to the panel installation.

## 6

## INPUT SETUP &amp; CALIBRATION

---

## 6.1 - Enter F1 PIN number









- A Enter the setup and calibration mode by pressing the **F1** button.
- \_\_\_ **ENTER F1 PIN NUMBER** scrolls across the display and toggles with **0**. Use the **↑** and **↓** buttons to enter your security code (factory default 1). Then press **P**. If the correct PIN is entered, setup is started at 6.2.
- If an incorrect PIN number is entered, \_\_\_ **INCORRECT PIN NUMBER – ACCESS DENIED** scrolls across the display and it returns to normal operating mode.
- 

You will have the opportunity to change your PIN number at the end of this section (6.8). If you have forgotten your PIN number, see Section 7.

---

## 6.2 - Totalizer setup









- A \_\_\_ **TOTALIZER SETUP** scrolls across the display and toggles with **SKIP**. Press **P** to skip to 6.3, or the **↑** button and then **P** to **ENTER** totalizer setup.
- B \_\_\_ **DECIMAL POINT POSITION** scrolls across the display and toggles with the currently selected decimal point position. Use the **↑** and **↓** buttons to select **NO DP, 0.1, 0.12, 0.123, 0.1234** or **0.12345**, and then press **P**.
- C \_\_\_ **PULSES PER UNIT OF MEASUREMENT** scrolls across the display and toggles with the currently selected number of pulses. Use the **↑** and **↓** buttons to adjust your number of pulses, and then press **P**.
- E.g. If an encoder outputs 1,500 pulses/metre, set this value to 1,500.*
- D \_\_\_ **ENTER DISPLAY VALUE FOR X PULSES** (where X is the number of pulses selected in 6.2C) scrolls across the display and toggles with the selected display value. Adjust this value as required using the **↑** and **↓** buttons, and press **P**.
- E.g. If you set 1,500 pulses in 6.2C, and 1,500 pulses = 1 metre, then enter 1 here.*
-

- E** \_\_\_ **DIRECTION** scrolls across the display and toggles with the currently selected count direction. Use the  and  buttons to select either **UP** or **DOWN**, and then press .
- F** \_\_\_ **RESET AT POWER UP** scrolls across the display and toggles with the current setting. Use the  and  buttons to choose between: **NO** (retain previous totalizer value at power up), **ZERO** (reset totalizer to zero at power up) or **LD VAL** (reset totalizer to custom load value [see 6.2G] at power up). When you have made a selection, press  to accept and continue.
- G** \_\_\_ **LOAD VALUE** scrolls across the display and toggles with the current totalizer load value. Use the  and  buttons to adjust this value if required, and then press .



*This value will be loaded into the totalizer at power up, if **LD VAL** is selected in 6.2F above. It will also be loaded into the totalizer if **TOT=LV** is executed via a user programmable input function (see 6.5).*

---















## 6.3 - Rate setup

- A** \_\_\_ **RATE SETUP** scrolls across the display and toggles with **SKIP**. Press  to skip to 6.4, or the  button and then  to **ENTER** rate setup.
- B** \_\_\_ **DECIMAL POINT POSITION** scrolls across the display and toggles with the currently selected decimal point position. Use the  and  buttons to select **NO DP**, **0.1**, **0.12**, **0.123**, **0.1234** or **0.12345**, and then press .
- C** \_\_\_ **ROUNDING** scrolls across and toggles with the current display rounding setting. Using the  and  buttons, select: **NONE**, **2**, **5** or **10**, and press .

*Rounding is quoted in display counts and is not influenced by decimal point position. For example, if your input signal is 5.3, the display will show: 5.3 (for rounding=**NONE**), 5.4 (for rounding=**2**), 5.5 (for rounding=**5**) or 5.0 (for rounding=**10**).*

- D** \_\_\_ **TIME PERIOD FOR RATE DISPLAY** scrolls across the display and toggles with the currently selected time period. Use the  and  buttons to select: **SECS**, **MINS** or **HOURS**, and then press .

*This parameter allows you to view the effective rate over different time periods. For example, if the units of measurement are metres, then the rate can be viewed in metres/second, metres/minute or metres/hour. The instrument will automatically calculate the required scale factors based on the input channel setup, so you must complete 6.2 first.*



- E** \_\_\_ **RATE MULTIPLIER** scrolls across the display and toggles with the current multiplication factor. This option adds a scale factor, to display the rate in the required units. Use the  and  buttons to select: **X0.0001**, **X0.001**, **X0.01**, **X0.1**, **X1**, **X10**, **X100** or **X1000**. Then press .
- F** \_\_\_ **HIGH SPEED MODE** scrolls across the display and toggles with the current selection. High speed mode should be turned on when the input signal is greater than 10,000pps (10kHz). Use the  and  buttons to select either **ON** or **OFF**, and then press .
- G** \_\_\_ **LOW CUT** scrolls across the display and toggles with the cutoff value for the rate display. When the rate drops below the low cut value, it displays as zero. Use the  and  buttons to adjust this value as required, and then press .
- H** \_\_\_ **DISPLAY ZERO TIME** scrolls across the display and toggles with the current display zero time. This value controls how quickly the rate display changes to zero. Use the  and  buttons to select either: **0.5SEC** (for inputs with >2 pulses/sec) or **100SEC** (for slow inputs). Then press .
- I** \_\_\_ **AVE SAMPLES** scrolls across the display and toggles with the currently selected averaging. Using the  and  buttons, alter the number of input samples that the controller will average, and then press .

*This instrument has input signal averaging, optimising stable measurement.*

*If the change in input exceeds the averaging window value it will not average, ensuring fast response when there are large differences between readings.*

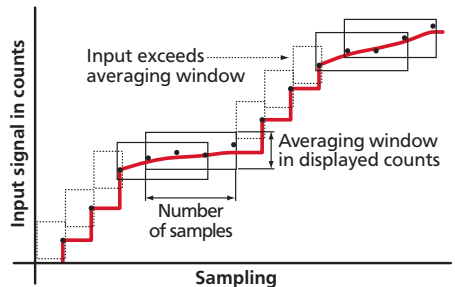
*Increasing the number of **AVE SAMPLES** will stabilise measurement, but it will also slow down response rates.*



- J** \_\_\_ **AVE WINDOW** scrolls across and toggles with the currently selected averaging window value. Using the  and  buttons, alter the signal averaging window, and then press .

*If your input signal contains large noise spikes, you can increase the size of the averaging window to ensure that these are still averaged. However, increasing the window size too far will reduce the ability of the instrument to respond quickly to real changes in input signal. Setting **AVE WINDOW** to 0 will give continuous averaging as per the selected averaging samples.*

## 6.4 - Display setup

- A** \_\_\_ **DISPLAY SETUP** scrolls across the display and toggles with **SKIP**. Press **P** to skip to 6.5, or the **↑** button and then **P** to **ENTER** display setup.
- B** \_\_\_ **DISPLAY SOURCE** scrolls across the display and toggles with the currently selected display source. Use the **↑** and **↓** buttons to select either **TOTAL** or **RATE**, and then press **P**.

## 6.5 - User programmable input functions

This section allows you to assign a custom function to the front panel **F2** button, or the rear *User Input* pins (see 3.5). The following functions are available:

### User programmable input functions

<b>NONE</b>	No action
<b>STORE</b>	Freezes the display value (totalizer and rate keep operating in the background)
<b>TOT=0</b>	Resets total value to zero
<b>TOT=LV</b>	Resets total value to load value (defined in 6.2G)

- A** \_\_\_ **USER PROGRAMMABLE INPUT FUNCTIONS** scrolls across the display and toggles with **SKIP**. Press **P** to skip to 6.6, or the **↑** button and then **P** to **ENTER** input functions setup.
- B** \_\_\_ **F2 BUTTON** scrolls across the display and toggles with the function to be executed when the **F2** button is pressed from the main display. Use the **↑** and **↓** buttons to make a selection (referring to the table above). Then press **P**.
- C** \_\_\_ **USER INPUT 1** scrolls across the display and toggles with the function to be executed when the User 1 input pin is activated (see 3.5). Use the **↑** and **↓** buttons to make a selection (referring to the table above), and then press **P**.
- D** \_\_\_ **USER INPUT 2** scrolls across the display and toggles with the function to be executed when the User 2 input pin is activated (see 3.5). Use the **↑** and **↓** buttons to make a selection (referring to the table above), and then press **P**.

## 6.6 - Analog output setup

*N.B. All new units are calibrated before shipping. Recalibration is **only** necessary if settings are wiped or the unit's accuracy requires verification after a long period of use. e.g. 1 year.*

**A** \_\_\_ **ANALOG OUTPUT SETUP** scrolls across the display and toggles with **SKIP**. If your unit does not have analog output installed, (or you do not wish to configure your analog output now), please press **P** to skip to 6.7.

Otherwise, press the **↑** button and then **P** to **ENTER** analog output setup.

**B** \_\_\_ **DATA SOURCE FOR ANALOG OUTPUT** scrolls across the display and toggles with the current analog output data source. Use the **↑** and **↓** buttons to select an option from: **NONE**, **TOTAL** or **RATE**, and then press **P**.

**C** \_\_\_ **LOW SCALE VALUE FOR ANALOG OUTPUT** scrolls across the display and toggles with the currently selected low scale value. Use the **↑** and **↓** buttons to enter your cal low position, and then press **P**.

*This sets the display value for **CAL LOW** (as in 6.6F, below).*

**D** \_\_\_ **HIGH SCALE VALUE FOR ANALOG OUTPUT** scrolls across the display and toggles with the currently selected high scale value. Use the **↑** and **↓** buttons to enter your cal high position, and then press **P**.

*This sets the display value for **CAL HIGH** (as in 6.6G, below).*

**E** \_\_\_ **CALIBRATE ANALOG OUTPUT?** scrolls across the display and toggles with **SKIP**. Use the **↑** and **↓** buttons to select **SKIP** or **ENTER**, and then press **P**.



**Factory analog output calibration is precisely set before shipping this instrument, and should not be adjusted unless advised by the manufacturer.**

➔ If you selected **SKIP**, please skip to 6.7 now.

➔ If you selected **ENTER**, connect a mA or volt meter across the analog output connector (see 3.3), and then continue to 6.6F.

**F** \_\_\_ **CAL LOW ANALOG OUTPUT** scrolls across the display and toggles with a calibration number shown in internal units (around -16000). Press the **↑** or **↓** buttons until the multimeter displays your target low output (e.g. 4mA), then press **P**.







- G** \_\_\_ **CAL HIGH ANALOG OUTPUT** scrolls across the display and toggles with a calibration number shown in internal units (around 30000). Press the  or  buttons, until the multimeter displays your target high output, then press .

---

## 6.7 - Serial setup



- A** \_\_\_ **SERIAL SETUP** scrolls across the display and toggles with **SKIP**. If your unit does not have a serial port installed, (or you do not wish to configure your serial options now), please press  to skip to 6.8.



Otherwise, press the  button and then  to **ENTER** serial setup.



- B** \_\_\_ **SERIAL MODE** scrolls across the display and toggles with the currently selected serial mode. Using the  and  buttons, choose either: **ASCII** (custom), **MODBUS** (RTU) or **RNGR A** (Ranger A), and then press .



➔ If you selected **ASCII** or **MODBUS**, skip to 6.7D now.

➔ If you selected **RNGR A**, continue to 6.7C now.

- C** \_\_\_ **SERIAL DATA SOURCE** scrolls across the display and toggles with the current Ranger A serial data source. Use the  and  buttons to select either **RATE** or **TOTAL**, and then press .

- D** \_\_\_ **BAUD RATE** scrolls across the display and toggles with the current selection. Use the  and  buttons to select one of: **300**, **600**, **1200**, **2400**, **4800**, **9600**, **19200** or **38400**. Then press .

- E** \_\_\_ **PARITY** scrolls across the display and toggles with the current selection. Using the  and  buttons, select: **NONE**, **ODD** or **EVEN**, and then press .

- F** \_\_\_ **SERIAL ADDRESS** scrolls across the display and toggles with the current address. Use the  and  buttons to alter the serial address, and press .

*The serial address parameter is used to identify a particular device when it is used with other devices in a system. (It applies particularly to **MODBUS** mode when used on an RS485 serial network.) The serial address of the controller must be set to match the serial address defined in the master device.*

---

Refer to Appendix A for more information on serial modes and registers.

---

## 6.8 - Edit F1 PIN number

- A** `__ _ EDIT F1 PIN NUMBER` scrolls across the display and toggles with **SKIP**. Press **P** to skip and return to the operational display, or the **↑** button and then **P** to **ENTER** and change your PIN number.
- B** `__ _ ENTER NEW F1 PIN NUMBER` scrolls across the display and toggles with the current PIN (default 1). Using the **↑** and **↓** buttons, enter your new calibration PIN number. Then press **P** to exit to the operational display.

### 7

#### RESET PIN NUMBER / VIEW FIRMWARE VERSION

---

If you have forgotten your PIN number, follow the procedure below to reset it to its factory default of 1.

This procedure will also allow you to view the current software installed on your device, which may be required for support purposes.

---

- A** Press **↑**, **↓** and **P** at the same time. (This key combination can be difficult to execute and you may need several tries to get it right.)
- B** A message will appear on the display, with details of the unit's current software configuration (Product name, Firmware Version, and Macro Version). At the end, you will see – **PIN NUMBERS RESET TO 1**.
- C** The PIN number has now been reset to '1'. You can change this, if required, by following the instructions in 6.8, using '1' to enter the menu initially.

## A.1 - Custom ASCII mode

Custom ASCII is a simple, custom protocol that allows connection to various PC configuration tools. ('Custom ASCII' differs from the 'Modbus (ASCII)' protocol used by some devices.) Custom ASCII command strings must be constructed in this order:

**<Start> <Controller Address> <Read/Write Command> <Register Address>  
<Separator Character> <Data Value> <Message Terminator>**

**Start** - Use 'S' for the start character of a command string (not case sensitive). This must be the first character in the string.

**Controller Address** - Use an ASCII number from '1' to '255' for the controller address. If the character following the start character is not an ASCII number, then address '0' is assumed. All controllers respond to address '0'.

**Read/Write Command** - Use ASCII 'R' for read, 'U' for unformatted read, or 'W' for write (not case sensitive). Any other character aborts the operation.

*In Custom ASCII mode, data is normally read as formatted data (which includes decimals and any text characters that may be selected to show units). However it is also possible to read unformatted data by using a 'U' in the read command. There is no unformatted write command, as when writing to fixed point registers, any decimal point and text characters are ignored.*

**Register Address** - The register address for the read/write operation will be an ASCII number from '1' to '65535'. This character must be specified for a write command, but may be omitted for a read command, (in which case the controller will respond with the data value currently on the display).

**Separator Character** - The separator character can be either a space or a comma, and is used to separate the register address from the data value.

**Data Value** - Must be an ASCII number. The absolute limits for this number are -1000000 to 1000000, but please note that not all registers will accept this range.

**Message Terminator** - This is the last character, and must be either a '\$' (dollar) or an '\*' (asterisk). Neither of these characters should be used elsewhere in the

message string. If '\$' is used, a 50ms minimum delay is inserted before a reply is sent. If '\*' is used, a 2ms minimum delay is inserted before a reply is sent.

#### Custom ASCII Read/Write Examples

Example	Description
SR\$	Read display value from all controllers, 50ms delay.
S15R\$	Read display value from controller address 15, 50ms delay.
S3U40*	Read unformatted data in channel 4 from controller address 3, 2ms delay.
S2W2 -10000\$	Write -10000 to the display register of controller address 2, 50ms delay.
SWT CHAN_1\$	Write ASCII text string Chan_1 to channel 1 text register, 50ms delay.

#### Custom ASCII Registers

##### 32 Bit Signed

Address	Function
2	Process display
4	Flow rate
5	Total
34	D/A scale low value
36	D/A scale high value

**Controller Response** - After the controller has completed a read or write instruction, it responds by sending a carriage return/line feed (CR/LF) back to the host. If the instruction was a read command, the CR/LF follows the last character in the ASCII string. If it was a write command, CR/LF is the only response sent back. The host must wait for this before sending further commands to the controller. If the controller encounters an error, it will respond with a null (0x00) CR/LF.

## A.2 - Modbus (RTU) mode

Modbus (RTU) is an industry standard RTU slave mode that allows connection to a wide range of devices. Modbus registers are all holding registers, and should be accessed via function codes 3 and 6.

Register addresses are displayed in the Modicon™ 5-digit addressing format. I.e. Register 65=40065 (subtract 1 for direct addressing).

---

### Modbus (RTU) Registers

---

32 Bit Signed (2 x 16 Bit)

LSW	MSW	Function
40513	(40514)	Process display
40517	(40518)	Flow rate
40519	(40520)	Total
40587	(40588)	D/A scale low value
40591	(40592)	D/A scale high value

---

## A.3 - Ranger A mode

Ranger A is a continuous output, used to drive remote displays and other instruments in the Rinstrum™ range. (Ranger is a trade name belonging to Rinstrum Pty Ltd.) Ranger A output strings are constructed as shown:

**<Start> <Sign> <Output Value> <Status> <End>**

**Start** - STX character (ASCII 02)

**Sign** - Output value sign (space for + and dash for -)

**Output Value** - Seven character ASCII string containing the current output value and decimal point. (If there is no decimal point, then the first character is a space. Leading zero blanking applies.)

**Status** - Single character output value status. 'U'=Under, 'O'=Over, 'E'=Error.

**End** - ETX character (ASCII 03)







---

## Define Instruments

### New Zealand (Head Office)

 10B Vega Place, Rosedale,  
Auckland 0632, New Zealand  
PO Box 245 Westpark Village,  
Auckland 0661, New Zealand

Ph: +64 (9) 835 1550

Fax: +64 (9) 835 1250

 [sales@defineinstruments.co.nz](mailto:sales@defineinstruments.co.nz)

[www.defineinstruments.co.nz](http://www.defineinstruments.co.nz)

### United States (Dallas, TX)

Ph: (214) 926 4950

 [sales@defineinstruments.com](mailto:sales@defineinstruments.com)

[www.defineinstruments.com](http://www.defineinstruments.com)

---