



## SERIES RPMC | STABILISENSE™ CRITICAL ROOM PRESSURE MONITOR

---



### FEATURES/BENEFITS

---

- Long term stable pressure measurement
- 2 SPDT relays allow for local alarming and alarming to control system
- Automatic or manual alarm reset
- Visual LED alarms provide immediate local alert allowing corrective action to be taken quicker to eliminate the problem from becoming widespread
- Stores peak and valley process readings
- Same installation diameter as Magnehelic® gage which simplifies field upgrade to RPMC StabilISENSE™ critical room pressure monitor
- Password protected setup menu ensures no errors by untrained personnel

### APPLICATIONS

---

- Clean manufacturing areas
- Semiconductor manufacturing
- Pharmaceutical
- Clean rooms
- Research labs
- Vivariums

### DESCRIPTION

---

The **Series RPMC StabilISENSE™ Critical Room Pressure Monitor** is designed for critical low differential pressure applications that require stringent pressure monitoring and alarming. The Series RPMC can be configured to monitor positive or negative pressure in protected environments and clean manufacturing areas. The RPMC is a complete system with a fixed segment LCD which enables access to pressure, security, calibration, and alarm setup. The StabilISENSE™ critical room pressure monitor has a brushed stainless steel bezel that allows for easy cleaning.

The RPMC StabilISENSE™ critical room pressure monitor has built-in status indication LEDs that will appear green when within the user-defined pressure set range and will appear orange when outside of the pressure set range. 2 SPDT independent control relays with adjustable deadbands are also provided along with a 4-20 mA process output.

## SPECIFICATIONS

<b>Service</b>	Air and non-combustible, compatible gases.
<b>Measurement Technology</b>	Capacitance cell.
<b>Wetted Materials</b>	Consult factory.
<b>Housing Material</b>	Die cast aluminum case and SS bezel.
<b>Accuracy</b>	±0.25% RSS (includes non-linearity: ±0.24%, hysteresis: ±0.05% and non-repeatability: ±0.05%), or ±0.5% RSS (includes non-linearity: ±0.49%, hysteresis: ±0.05% and non-repeatability: ±0.05%).
<b>Pressure Limits</b>	2 psig.
<b>Temperature Limits</b>	32 to 140°F (0 to 60°C).
<b>Compensated Temperature Limits</b>	32 to 140°F (0 to 60°C).
<b>Thermal Effects</b>	0.030%/°F (0.050/°C) from 77°F (25°C).
<b>Power Requirements</b>	12-28 VDC, 12-28 VAC 50 to 400 Hz.
<b>Power Consumption</b>	3 VA max.
<b>Output Signal</b>	4-20 mA DC into 900 Ω max.
<b>Zero and Span Adjustments</b>	Accessible via menus.
<b>Response Time</b>	8 ms.
<b>Display</b>	Backlit 4 digit LCD 0.4" height LED indicators for set point and alarm status.
<b>Electrical Connections</b>	15 pin male high density D-sub connection. 18" (46 cm) cable with 10 conductors included.
<b>Process Connections</b>	1/8" female NPT. Side or back connections.
<b>Mounting Orientation</b>	Mount unit in vertical plane. Size: 4-3/4" (120.7 mm) OD x 2-21/32 (67.5 mm).
<b>Weight</b>	1.90 lb (794 g).
<b>Agency Approvals</b>	CE.

## SWITCH SPECIFICATIONS

<b>Switch Type</b>	2 SPDT relays.
<b>Electrical Rating</b>	1 A @ 30 VAC/VDC.
<b>Set Point Adjustment</b>	Adjustable via keypad on face.

# DIMENSIONS

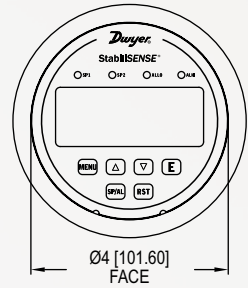
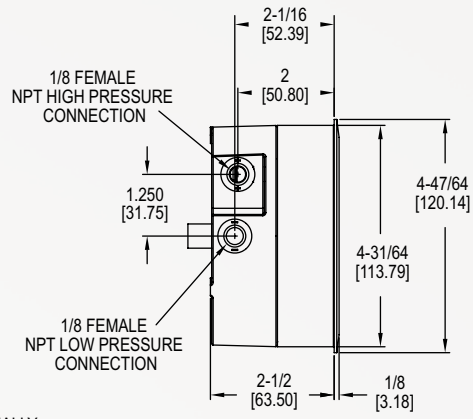
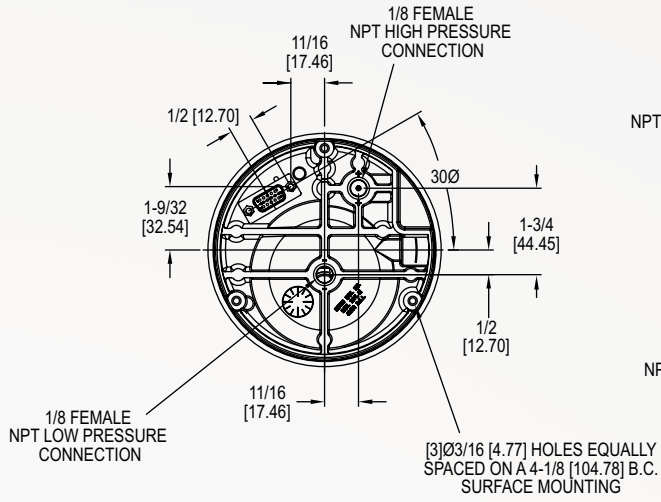

## HOW TO ORDER

Use the **bold** characters from the chart below to construct a product code.

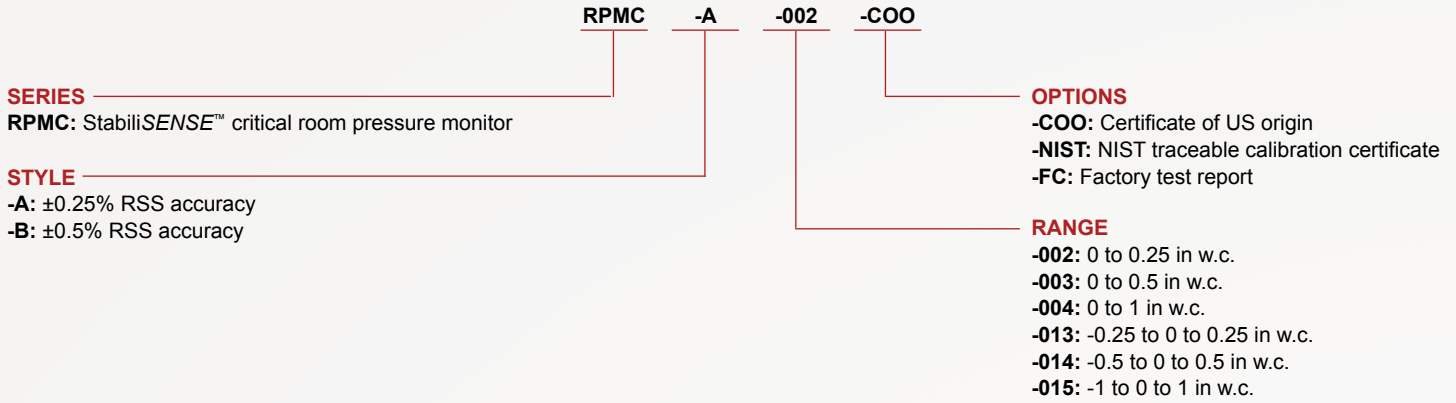

## ACCESSORIES

Model	Description
<b>A-220</b>	Clear flexible vinyl tubing is easily inspected, and is therefore best for test applications where a possibility of fluid entering the tubing exists. 3/16" ID x 5/16" OD, lengths to 500'; 45 psi maximum pressure @ 73°F
<b>A-285</b>	Remote alarm annunciator with visible/audible alarm and acknowledge switch
<b>A-299</b>	Mounting bracket flush mount Magnehelic® gage in bracket. Bracket is then surface mounted. Steel with gray hammertone epoxy finish 6.3" x 7.7" x 4.0", 1.30 lb
<b>A-300</b>	Flat aluminum bracket for flush mounting
<b>A-418A</b>	Static pressure pickup. Room mount with delta style plastic enclosure fits 2" x 4" electrical box. Fine mesh screen hides static pressure pickup port. Clean connection to 1/8" to 3/16" I.D. tubing and pressure sensor. Sealed with foam gasket, screws included.
<b>A-465</b>	Flush mount space pressure sensor, white plastic
<b>A-471A</b>	Static pressure pickup. For use in clean rooms, 60 micron filter picks up static pressure. Stainless steel wall plate fits 2" x 4" electrical box. Sealed with foam gasket, screws included. Barbed brass fitting holds 1/8" to 3/16" ID tubing

**ORDER ONLINE TODAY!**

[dwyer-inst.com/Product/SeriesRPMC](http://dwyer-inst.com/Product/SeriesRPMC)



**DWYER INSTRUMENTS, INC.**

©Copyright 2020 Dwyer Instruments, Inc.  
Printed in U.S.A. 8/20

DS-RPMC Rev. 1

Important Notice: Dwyer Instruments, Inc. reserves the right to make changes to or discontinue any product or service identified in this publication without notice. Dwyer advises its customers to obtain the latest version of the relevant information to verify, before placing any orders, that the information being relied upon is current.