

EZ-ZONE® ST Integrated Control Loop Makes Solving the Thermal Requirements of Your System Easy

The EZ-ZONE® ST integrated solid state controller from Watlow® offers a complete thermal system control solution in a single package. Features include a PID temperature controller connected to a high-amperage solid state relay with the option of adding a properly sized heat sink, an over- and under-temperature limit, a power shut-down contactor, digital communications and a remote user interface in one complete and professionally engineered product.

Because the system is modular and scalable, a user only pays for what is needed. Stacking the EZ-ZONE ST integrated controller into multiple configurations enables flexibility to standardize the product platform to solve a wide range of application needs.

This integrated controller also includes 200KA short circuit current rating (SCCR) tested up to 480VAC to minimize damage in the event of a short circuit when used with required fusing.

Features and Benefits

Back panel or DIN-rail mount

- Provides several mounting options

Compact package

- Reduces panel size

Touch-safe package

- Complies to IP2X increasing user safety

±0.1 percent temperature accuracy

- Provides efficient and accurate temperature control

200KA SCCR with proper fusing

- Minimizes damage in the event of a short circuit

Agency approvals: UL®, CSA, CE, RoHS, W.E.E.E.

- Meets applications requiring agency approvals

Three-year warranty

- Ensures Watlow's reliability and product support

Off-the-shelf designed system solution

- Improves system reliability and termination reduction
- Reduces installation cost
- Eliminates incompatibility headaches often encountered with using many different components and brands

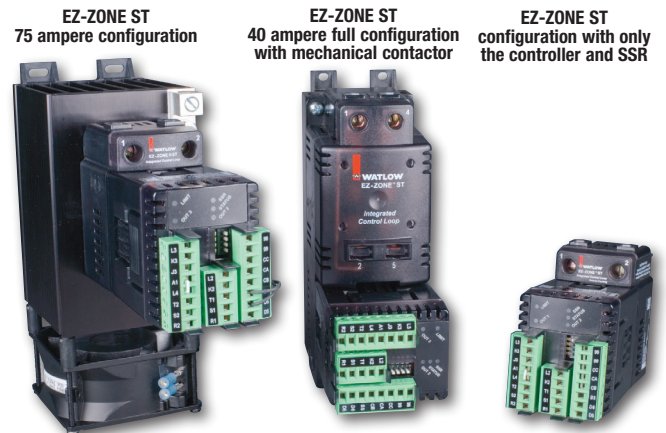

Features and Benefits (con't)

Profile capability

- Includes ramp and soak with four files and 40 total steps

Ability to communicate with programmable logic controller (PLC), personal computer (PC) or operator interface (OIT)

- Optional EIA 485 Modbus® RTU
- RUI/communications gateway with optional EIA 232/485 Modbus® RTU, EtherNet IP™/TCP Modbus®, DeviceNet™ or PROFIBUS DP

Solid state relay output

- Allows faster cycling, more precise control, increased heater life and energy efficiency
- Ability to handle up to 75 amperes
- Uses either zero-cross or phase angle control modes for flexibility to control resistive loads such as nichrome, tungsten or quartz lamps
- Utilizes phase angle control mode to prevent load failure or blowing fuses for tungsten or quartz loads

PID temperature control

- Allows single input/dual output
- Allows standard PID or adaptive TRU-TUNE®+ tuning algorithms for demanding controllability requirements

Optional temperature limit

- Increases safety in over- and under-temperature condition

Optional definite purpose mechanical contactor

- Enables circuit safety shut down driven by limit control or PID alarm output signal

Optional current monitoring feature

- Detects heater current flow and alarm indication of failed solid state relay (SSR) or heater zone

Optional SSR heat sink

- Sized and engineered for specific applications
- Factory supplied heat sink is UL® listed

System diagnostics

- Provides continuous self-monitoring alerts when there is any system trouble to reduce maintenance and service costs

PC Software—EZ-ZONE Configurator

- Wizard style configuration of controller settings
- On-line or off-line recipe editing

Specifications

Line Voltage/Power

- 100 to 240VAC, +10/-15%; (85-264VAC), 50/60Hz, $\pm 5\%$
- 24VAC/VDC, +10/-15%; 50/60Hz, $\pm 5\%$
- 12VA max. power consumption without mechanical contactor in system
- 50VA max. power consumption with mechanical contactor used in system, 140VA if using external contactor
- Data retention upon power failure via nonvolatile memory

Environment

- 0 to 158°F (-18 to 70°C) operating temperature
- -40 to 185°F (-40 to 85°C) storage temperature
- 0 to 90% RH, non-condensing

Accuracy

- Calibration accuracy and sensor conformity: $\pm 0.1\%$ of span, $\pm 1^\circ\text{C}$ @ the calibrated ambient temperature and rated line voltage
 - Types R, S, B: 0.2%
 - Type T below -50°C : 0.2%
- Calibration ambient temperature @ $77^\circ\text{F} \pm 5^\circ\text{F}$ ($25^\circ\text{C} \pm 3^\circ\text{C}$)
- Accuracy span: 1000°F (540°C) min.
- Temperature stability: $\pm 0.1^\circ\text{F}/^\circ\text{F}$ ($\pm 0.1^\circ\text{C}/^\circ\text{C}$) rise in ambient max.

Agency Approvals

- UL®, CSA, CE (zero cross models only), RoHS, W.E.E.E.
- Limit version features FM approval

Controller

- Microprocessor based user-selectable control modes
- PID module: single universal input, 2 outputs
- Limit module: single universal input, 2 outputs
- Two total additional digital input/outputs shared between PID and limit functions
- Control sampling rates: input = 10Hz, outputs = 10Hz
- Isolated EIA 485 Modbus® RTU serial communications

Wiring Termination—Touch Safe Terminals

- Input, power and controller output terminals touch safe removable 12 to 22 AWG
- Power load terminals 6 to 12 AWG
 - Tightening torque: 30 in.-lbs

Universal Input

- Thermocouple, grounded or ungrounded sensors
 - $> 20\text{M}\Omega$ input impedance
 - Max. of 20 Ω source resistance
- RTD 2- or 3-wire, platinum, 100 Ω and 1000 Ω @ 0°C calibration to DIN curve (0.00385 $\Omega/^\circ\text{C}$)
- Process, 0-20mA @ 100 Ω , or 0-10VDC @ 20k Ω input impedance; scalable, 0-50mV
- Inverse scaling

Digital Input

- Update rate: 1Hz
- Dry contact or dc voltage
 - DC voltage
 - Max. input: 36V at 3mA
 - Min. high state: 3V at 0.25mA
 - Max. low state: 2V

Dry contact

- Max. short circuit: 13mA
- Min. open resistance: 500 Ω
- Max. closed resistance: 100 Ω

Current Measurement

- Accuracy: typical $\pm 1\text{A}$, max. error $\pm 3\text{A}$
- Accuracy and operating range: 0 to 75A

Digital Output

- Update rate: 1Hz
- Output voltage: 24V, current limit 10mA

Allowable Operating Range

- Type J: 32 to 1500°F or 0 to 815°C
- Type K: -328 to 2500°F or -200 to 1370°C
- Type T: -328 to 750°F or -200 to 400°C
- Type N: 32 to 2372°F or 0 to 1300°C
- Type E: -328 to 1470°F or -200 to 800°C
- Type C: 32 to 4200°F or 0 to 2315°C
- Type D: 32 to 4200°F or 0 to 2315°C
- Type F: 32 to 2543°F or 0 to 1395°C
- Type R: 32 to 3200°F or 0 to 1760°C
- Type S: 32 to 3200°F or 0 to 1760°C
- Type B: 32 to 3300°F or 0 to 1816°C
- RTD (DIN): -328 to 1472°F or -200 to 800°C
- Process: -1999 to 9999 units

Output Hardware

- User selectable for heat/cool as on-off, P, PI, PD, PID, or alarm action. Not valid for limit controls
- Electromechanical relay. Form A, rated 2A
- SSR drive: 20-28VDC low side open collector switch
- SSR, Form A, 0.5A @ 24VAC min., 264VAC max., opto-isolated, without contact suppression
- Electromechanical relay, Form A, rated 5A, auxiliary output on PID module, output 2
- Electromechanical relay, Form C, rated 5A, auxiliary output on limit module, output 3

Specifications for Basic Remote User Interface EZKB (RUI)

Operator Interface

- Dual 4 digit, 7 segment LED displays
- Forward, backward, up and down keys plus a customer programmable function key - EZ key
- Typical display update rate: 1Hz
- Agency approved to IP65/NEMA 4X
- Standard bus (ships with all units). Options: EIA 232/485 Modbus® RTU, EtherNet/IP™/TCP Modbus® or DeviceNet™, PROFIBUS DP

Line Voltage/Power

- 100 to 240VAC, +10/-15%; (85-264VAC) 50/60Hz, $\pm 5\%$
- 24VAC/VDC, +10/-15%; 50/60Hz, $\pm 5\%$

Specifications for Mechanical Contactor

- Insulation class: UL® Class B 266°F (130°C)
- Min. load of 100 watts
- Duty cycle: continuous

Contact Ratings

Full Load Amperes	Number of Poles	Line Voltage	Locked Rotor Amps	Resistive Amp Rating	Max. Horsepower	
					Voltage	Single-Phase
40	2	240/277	240	50	120	2
		480	200	50	240	3
		600	160	50		

EZ-ZONE ST Solid State Relay with Heat Sink Specifications

Temperature and SSR Amperage Performance Curve
Watlow 25, 40 and 75 Ampere Solid State Relays

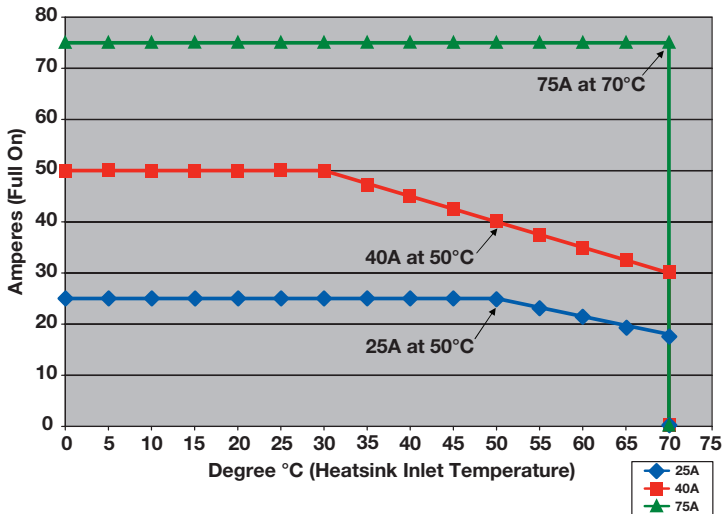

All Versions			
Current output (50°C)	25 Amps	40 Amps	75 Amps
One-cycle surge current	600Apk	850Apk	1350Apk
Max. I ^t for fusing	1500A ² s	3000A ² s	7560A ² s
Thermo resistance	0.35°C/W	0.2°C/W	0.14°C/W
Base plate temperature (max.)	116°C	115°C	112°C
Forward voltage drop	1.3Vpk	1.3Vpk	1.3Vpk
Min. holding current	150mA	150mA	250mA
Frequency	47 to 63Hz	47 to 63Hz	47 to 63Hz

Time Proportioned Models	
Off-state leakage	1mA
Max. off-state dv/dt	500V/μsec
120/240VAC	
Output voltage range	24 to 280VAC
Over voltage rating	600Vpk
Input voltage range	0 to 28VDC
277/600VAC	
Output voltage range	48 to 660VAC
Over voltage range	1200Vpk
Input voltage range	0 to 28VDC

Phase Angle Models	
Off-state leakage	6mA
Max. off-state dv/dt	200V/μsec
120/240VAC	
Output voltage range	100 to 240VAC
Over voltage rating	600Vpk
Input voltage range	2.7 to 10VDC
277/600VAC	
Output voltage range	260 to 600VAC
Over voltage range	1200Vpk
Input voltage range	2.8 to 10VDC

RUI (EZKB) Utilized as a Communication Gateway Device

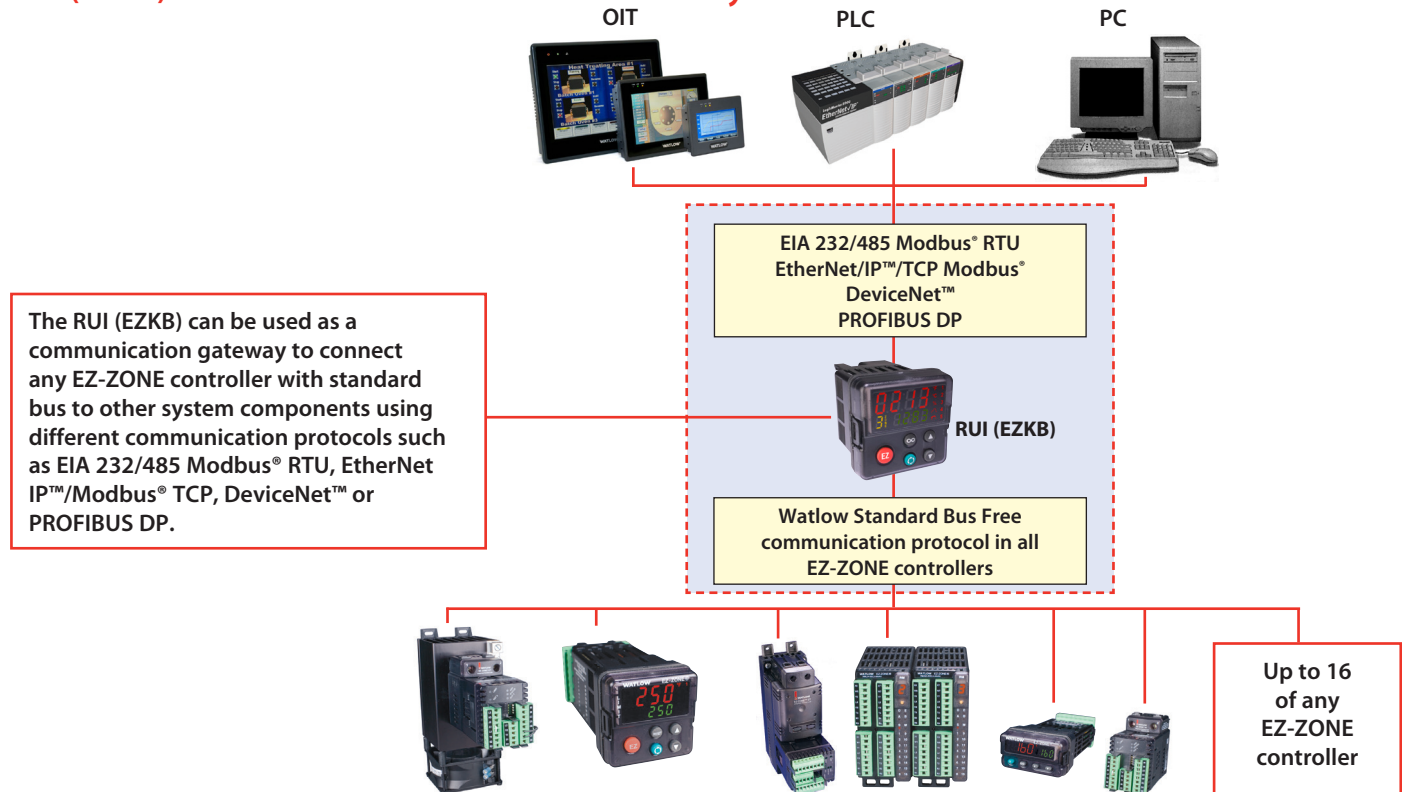

EZ-ZONE ST with Definite Purpose Mechanical Contactor—Dimensional Drawing

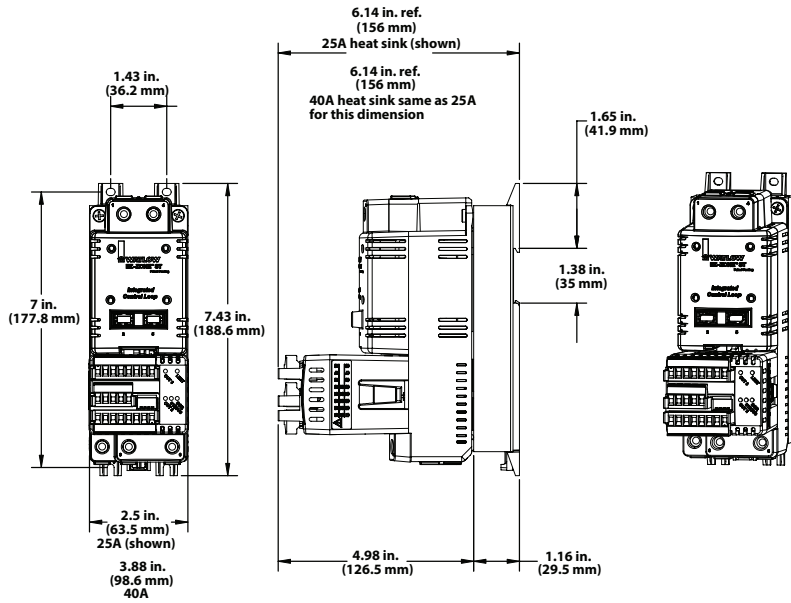

Note: EZ-ZONE ST needs to be mounted vertically (as shown) to meet amp/ambient performance curve.

EZ-ZONE ST with 25 or 40A Heat Sink, without Definite Purpose Mechanical Contactor—Dimensional Drawing

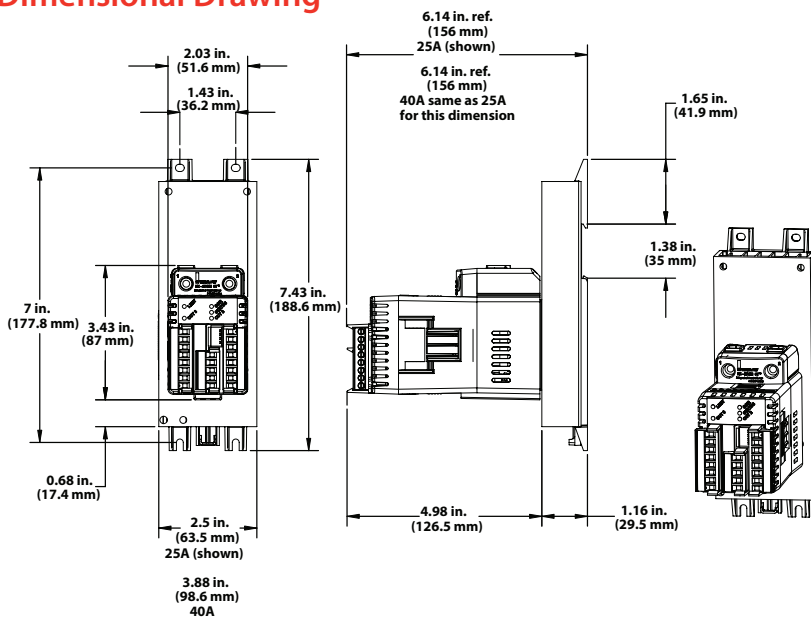

Note: EZ-ZONE ST needs to be mounted vertically (as shown) to meet amp/ambient performance curve.

EZ-ZONE ST with 75A Heat Sink, without Definite Purpose Mechanical Contactor—Dimensional Drawing

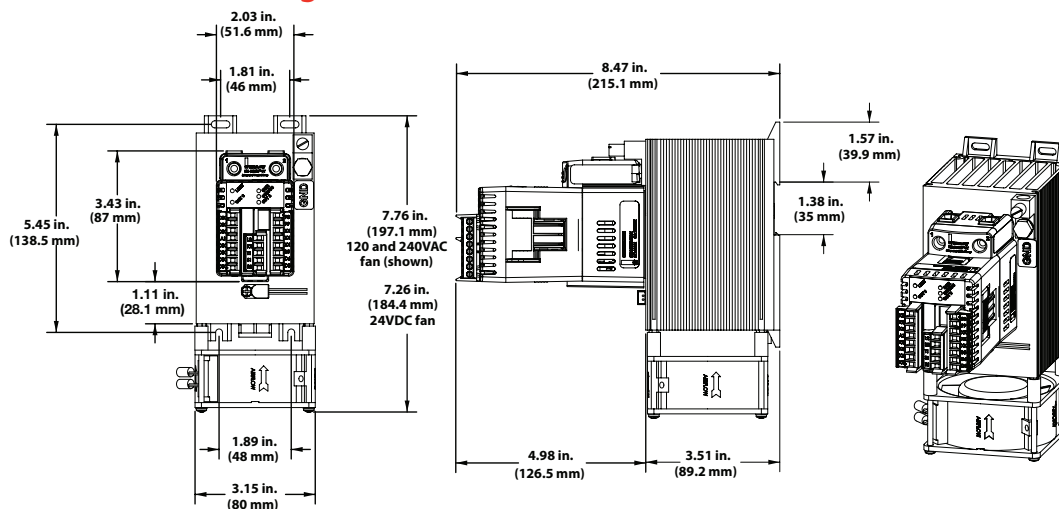

Note: EZ-ZONE ST needs to be mounted vertically (as shown) to meet amp/ambient performance curve.

Communications

Selecting the right communications ordering option for the EZ-ZONE ST:

Correct Ordering Option Letter	Connecting To	Another EZ-ZONE Product	RUI, EZ-ZONE Configurator, SpecView	Third Party Device (PLC, PC, Touch Panel, etc.)	Silver Series Operator Interface Terminal
Option A*			Yes		
Option M**				Yes - Via Modbus®	Yes - Via Modbus®
Option A*		Yes	Yes		
Option M**		Yes		Yes - Via Modbus®	Yes - Via Modbus®

*A = Standard bus used to connect to Watlow PC software, RUI, other EZ-ZONES

**M = Modbus® RTU (needed to communicate to third-party devices) and standard bus. User selectable

Ordering Information

Part Number

① ②	③	④	⑤ ⑥	⑦	⑧	⑨	⑩	⑪ ⑫
ST	Integrated PID Controller	Integrated Limit Controller	Mech. Cont. & Power Supply Options	Communications	SSR	Heat Sink/ DIN-Rail Mtg. Brkt.	Firmware	Customization
ST								

③ Integrated PID Controller				
	Output 1*	Output 2	Total of 2 Digital I/O Points	Current Measurement
K =	SSR drive	0.5A SSR	No	No
B =	SSR drive	0.5A SSR	Yes	No
P =	SSR drive	0.5A SSR	No	Yes
E =	SSR drive	0.5A SSR	Yes	Yes
H =	SSR drive	5A mechanical relay	No	No
D =	SSR drive	5A mechanical relay	Yes	No
J =	SSR drive	5A mechanical relay	No	Yes
C =	SSR drive	5A mechanical relay	Yes	Yes

* Output 1 is dedicated to providing the command signal to the internal SSR.

Note: If 75A heat sink is selected below, then 1 digital I/O will be factory set and fixed as the SSR over-temperature digital input.

④ Integrated Limit Controller	
A =	None
L =	Limit control module with output 3, 5A Form C mechanical relay; with output 4, 2A Form A mechanical relay
B =	No limit control module but access to coil connection on mechanical contactor

⑤ ⑥ Mechanical Contactor and Power Supply Options	
AH =	No contactor and universal high voltage power supply 100-240VAC/VDC
AL =	No contactor and universal low voltage power supply 24-28VAC/VDC
B1 =	Single pole, 40A Watlow contactor, 24VAC power supply
B2 =	Single pole, 40A Watlow contactor, 110/120VAC power supply
B3 =	Single pole, 40A Watlow contactor, 208/240VAC power supply
F1 =	Dual pole, 40A Watlow contactor, 24VAC power supply
F2 =	Dual pole, 40A Watlow contactor, 110/120VAC power supply
F3 =	Dual pole, 40A Watlow contactor, 208/240VAC power supply

⑦ Communications	
A =	Standard bus used to connect to Watlow PC software, RUI, other EZ-ZONES
M =	485 Modbus® RTU (needed to communicate to third-party devices) and standard bus. User selectable

⑧ SSR	
B =	Zero cross 10A (24 to 240VAC output)
C =	Zero cross 25A (24 to 240VAC output)
D =	Zero cross 40A (24 to 240VAC output)
E =	Zero cross 50A (24 to 240VAC output)
K =	Zero cross 75A (24 to 240VAC output)
F =	Zero cross 90A (24 to 240VAC output)
G =	Zero cross 25A (48 to 600VAC output)
H =	Zero cross 40A (48 to 600VAC output)
L =	Zero cross 75A (48 to 600VAC output)
J =	Zero cross 90A (48 to 600VAC output)
M =	Phase angle 25A (100 to 240VAC output)
N =	Phase angle 40A (100 to 240VAC output)
P =	Phase angle 75A (100 to 240VAC output)
R =	Phase angle 25A (260 to 600VAC output)
S =	Phase angle 40A (260 to 600VAC output)
T =	Phase angle 75A (260 to 600VAC output)

Note: EZ-ZONE ST phase angle is designed to work with tungsten or quartz loads. The EZ-ZONE ST should not be used with globars, molybdenum, graphite or transformer loads.

⑨ Heat Sinks/DIN-Rail Mounting Bracket	
A =	None
B =	25A
C =	40A
D =	75A 24VDC fan cooled
E =	75A 115VAC fan cooled
F =	75A 240VAC fan cooled

Note: If heat sink option D, E or F is selected you must also order integrated PID controller options B, E, D or C. 75A heat sink option includes SSR over-temperature thermostat shut-down feature.

⑩ Firmware	
A =	Standard Watlow
P =	Profile ramp and soak (40 total steps, 1 to 4 profiles total)
S =	Custom

⑪ ⑫ Customization (logo, parameters, hardware, firmware)	
AA =	Standard
XX =	Letters to be determined, contact factory

Note: Maximum rating of final configured product is determined by the lowest component rating of either the mechanical contactor, solid-state relay or heat sink. Maximum UL® rating for product is 75A.

Remote User Interface (RUI)— Dimensional Drawings

Front View

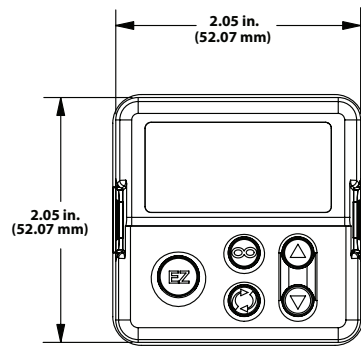

Short Case Version

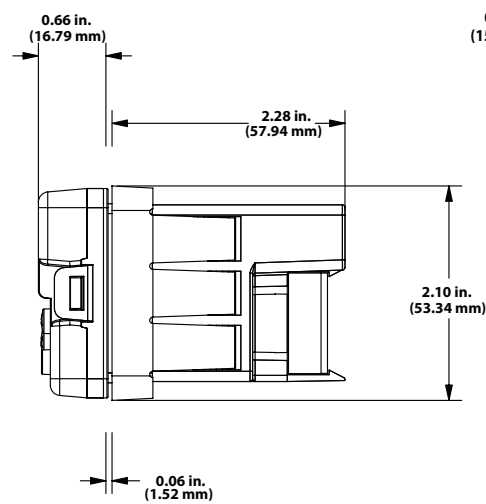

Long Case Version

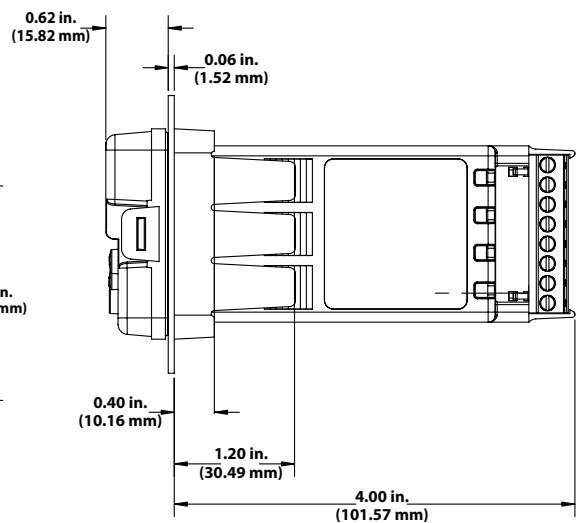

Ordering Information

Part Number

① ② ③	④	⑤	⑥	⑦ ⑧	⑨ ⑩	⑪ ⑫
EZK	Remote User Interface	Power Supply Voltage for RUI	Comm. Gateway Options	Custom RUI	Future Options	Custom Options
					AA	

④ Remote User Interface (RUI)	
B =	Basic 1/16 DIN
⑤ Power Supply Voltage for RUI	
L =	Low voltage 24-28VAC/VDC
H =	Universal high voltage 100-240VAC/VDC
⑥ Communication Gateway Options* (Standard Bus Always Included)	
A =	None
2 =	EIA232/485 Modbus® RTU
3 =	EtherNet/IP™/Modbus® TCP
5 =	DeviceNet™
6 =	PROFIBUS DP
* Options 2 through 6 require the long case dimensions	
⑦ ⑧ Custom RUI	
AA =	None
12 =	Custom options, contact factory
⑪ ⑫ Custom Options	
AA =	None
XX =	Class 1, Div. 2 (only available with communication options 2, 3, 5 and 6)

Watlow®, EZ-ZONE® and TRU-TUNE® are registered trademarks of Watlow Electric Manufacturing Company.
UL® is a registered trademark of Underwriter's Laboratories Inc.
Modbus® is a registered trademark of Schneider Automation Incorporated.
DeviceNet™ and EtherNet/IP™ are trademarks of Open DeviceNet Vendors Association.

Compatible Accessories

The EZ-ZONE configurator software is available FREE as a download at www.watlow.com. Looking for an easy-to-use method for configuring all parameter settings via PC? Simply download the EZ-ZONE configurator software and connect via the standard bus communication protocol. The communication protocol is included with every EZ-ZONE ST.



Watlow also offers a line of Operator Interface Terminals (OIT). Refer to the Watlow Silver Series OIT product specification sheet on the web at www.watlow.com

SpecView from Watlow is designed for industrial users and includes features such as data logging, trending and support for bar code readers and touch screens. Errors are reduced for any process by creating application-specific screens. The software provides a historical replay option, easy-to-use recipe features and remote access options, including LAN, internet and modem.



Powered by Possibility

To be automatically connected to the nearest North American Technical Sales Office:
1-800-WATLOW2 • www.watlow.com
inquiry@watlow.com

International Technical Sales Offices:

China	+86 21 3532 8532	Italy	+39 02 4588841	Singapore	+65 6773 9488
France	+33 1 41 32 79 70	Japan	+81 3 3518 6630	Spain	+34 91 675 1292
Germany	+49 7253 9400 0	Korea	+82 2 2169 2600	Taiwan	+886 7 288 5168
India	+91 40 6661 2700	Mexico	+52 442 256 2200	UK	+44 115 964 0777