

MTL RTK SmartAlarm range

Alarm annunciator



DECLARATION OF CONFORMITY

A printed version of the Declaration of Conformity has been provided separately within the original shipment of goods. However, you can find a copy of the latest version at

<http://www.mtl-inst.com/certificates>

GENERAL SAFETY INFORMATION

The following methods are used in this manual to alert the user to important information:-

 <p>WARNING</p>	<p>WARNING !</p> <p>Warnings are provided to ensure operator safety and MUST be followed.</p>
--	---

<p>CAUTION</p> <p>Cautions are provided to prevent damage to the instrument</p>
--

<p>NOTE</p> <p>These are used to give general information to ensure correct operation</p>
--

Table of Contents

DECLARATION OF CONFORMITY	1
GENERAL SAFTEY INFORMATION	2
1 Annunciator Model Code Definition	1
2 - INTRODUCTION	3
2.1 General	3
Available Versions	3
Card Locations	4
2.1.1 PSU/Common Services Card	4
2.1.2 Alarm Cards (8 Channel)	5
2.1.3 Pluggable LED's	6
2.1.4 Input Isolation	7
2.1.5 Bi-Polar Inputs	7
2.1.6 Standard Input Version	7
2.1.7 Optional Powered Input Versions	7
2.1.8 Integral Pushbuttons	7
2.1.9 Customer Terminals	7
2.1.10 Terminals For Use With External Pushbutton Inputs	8
2.1.11 Internal Audible Alarm	8
2.1.12 HNA & HNB Horn Relays	9
2.1.13 GPA & GPB Common Alarm Group Relays	10
2.1.14 WD Watchdog Relay	11
2.1.15 Watchdog Monitoring LED's	11
2.1.16	13
Diagnostic / Program mode -	13
Dynamic Contact Status	13
2.1.17 Diagnostic / Program mode - Manually changing the input type	14
2.1.18 Diagnostic / Program mode - Communication Monitoring	15
2.1.19 Programmable Features	16
Programmable Features	16
2.1.20 Film Legends	16
2.1.21 Window Numbering System	18
2.1.22 USB Programming Port	19
3 PRIMARY POWER	19
Primary Power – PS1	20
3 AUX POWER	21
Aux Power – PS2	21
4 – SIGNAL INPUT TYPES	21
Internally Powered 24VDC Signal Inputs	22
Signal Supply Fuse Location (FCV)	23
Alternative Connection Method	24
125VDC/AC or 250VDC/AC Customer Powered Inputs	25
125VDC/AC or 250VDC/AC Alternative Connection Method	26
5 HORN RELAYS	27
HNA & HNB Horn Relays	27
6 COMMON ALARM GROUP RELAYS	28
GPA & GPB Group Relays	28
7 REMOTE PUSHBUTTON INPUTS	29
Pushbutton Functions	29
Group Inhibit Function	30
Sleep Mode Function	30
8 INDIVIDUAL CHANNEL REPEAT RELAYS	32
Input Follower	32
Logic Follower	32

Display Follower.....	32
Contact Rating.....	32
9 TYPICAL SMARTALARM REAR VIEW	33
10 INSTALLATION	34
Unpacking.....	34
Mounting.....	34
Dimensions for panel mounting versions.....	34
19" Rack Mounting.....	35
Wall Mounting.....	35
Floor Standing.....	35
.....	35
11 SOFTWARE INSTALLATION	36
Recommended Guidelines.....	36
11.1 Security.....	36
11.1.1 Configuration executable.....	36
11.1.2 Configuration file.....	36
11.1.3 Log file.....	36
11.2 Other security Considerations.....	37
11.4.1 Log file.....	37
11.4.2 Scan File.....	38
12 – AUTO DETECT HARDWARE.....	40
13 IMPORT CSV FILE	41
Open Configuration.....	41
14 EXPORT CSV FILE	41
Save Configuration.....	41
15 CREATE A NEW SYSTEM.....	42
16 SYSTEM SETTINGS	43
Auto Detect.....	43
View.....	44
Advanced.....	44
Front View of Annunciator.....	44
Tools.....	45
Send Settings.....	45
Receive Settings.....	45
Restore Default Settings.....	45
Diagnostics.....	46
Set Structure.....	46
Scan Unit.....	46
Test Tools.....	46
General Tab.....	47
Plant Name.....	47
Description.....	47
Tag No.....	48
Serial No.....	48
Address Offset.....	48
Sleep Without Indication.....	48
CS Relays (Common Service Relays).....	49
Horn A - HNA.....	49
Horn B - HNB.....	50
Group A - GPA.....	50
Group B - GPB.....	50
Optional Settings.....	50
Assigning Relays to Groups.....	50
Reflash Function.....	51

Disable in System Test	51
Disable in Sleep Mode	51
Reflash Pulse Length	51
Alternative Functions for any Relay	51
Local Pushbuttons	52
Remote Pushbuttons	53
Inhibit Function	55
Assigning Channel to Inhibit Groups	55
Assigning a Remote Pushbutton Input to Inhibit	56
Sleep Mode	57
Assigning a Remote Pushbutton Input to Sleep Mode	58
Common Relay Operating In Sleep Mode	59
Inhibiting Common Relays During Sleep Mode	59
Sleep Mode Heartbeat	60
Disabling Sleep Mode Heartbeat	60
Horn	60
Auto Acknowledge	62
Auto Silence	63
Groups	64
Group Types	64
First-Up Group	64
Input Group	65
Audible Group	65
Ring back Audible Group	65
Grouping Example	66
Grouping Example 1	67
Grouping Example 2	68
Grouping Example 3	69
Communications	70
17 INDIVIDUAL CHANNEL SETTINGS	71
Configuring Individual Channels	71
Configuring Selective channels	71
Configuring Multiple channels	71
Channel	72
Alarm Legend	72
Manual Inhibit	72
Group Inhibit	72
Auto Shelving	73
Input	74
Contact Type	74
Delay Timers	74
Abnormal Delay (mS)	74
Normal Delay (mS)	75
Remote	75
Relay	76
Coil Status	76
Relay Function	77
Abnormal Delay	77
Normal Delay	77
Sequence	78
ISA Sequences	78
PB Groups	79
Global Pushbutton Group	79
Multiple Pushbutton Groups	79
Groups	80
18 ALARM SEQUENCES	81
ISA A – Automatic Reset – Lock In	83
ISA A-1-2 – Automatic Reset – Silence Pushbutton Interlock	84
ISA A-4 – Automatic Reset – Non Lock In	85

ISA A-4-5 – Automatic Reset – No Flashing.....	86
ISA A-4-5-6 – Status.....	87
ISA A-5 – Automatic Reset – No Flash.....	89
ISA M – Manual Reset – Lock In.....	90
ISA M-1-2 – Manual Reset – Silence Pushbutton Interlock.....	91
ISA R – Ringback.....	92
ISA F1A-1 – Automatic Reset First Up.....	93
ISA F2M-1 – Manual Reset First Up.....	94
ISA F2A-1 – Automatic Reset First Up.....	95
ISA F3A – Automatic Reset First Up.....	96
ISA F3A-3 – First Out Reset Interlock.....	97
ISA F3M – Manual Reset First Out.....	97
ISA F3M-1-2 – Manual Reset First Out with Silence Interlock.....	97
19 COMMUNICATIONS	99
Connection Details.....	99
Port 1 Connection Details – Smart Alarm.....	99
MODBUS RTU.....	100
Modbus Slave – Standard Communications.....	102
Read Coil Status – Function 01 – Read Request – Master.....	102
Read Coil Status – Function 01 – Read Response - Slave.....	102
Read Status – Function 03 – Read Request – Master.....	103
Read Status – Function 03 – Read Response - Slave.....	103
Write Multiple Coils – Function 15 - Read Request – Master.....	105
Write Multiple Coils – Function 15 – Read Response - Slave.....	105
20 SPECIFICATIONS	106
Primary power supply.....	106
Aux power supplies.....	106
Maximum Power.....	106
Signal Inputs.....	106
Input response time.....	106
First-Up discrimination.....	106
Individual channel repeat relays.....	107
HNA & HNB Horn Relays.....	107
GPA & GPB Common Alarm Group Relays.....	107
Watchdog Relay.....	107
Audible alarms.....	107
Communications.....	107
Environmental Specifications.....	108
Temperature.....	108
Protection.....	108
EMC Compliance.....	108
IEC61326-1: 2013.....	108
Radiated RFI Immunity.....	108
Conducted RFI Immunity.....	108
Radiated Emissions.....	108
Conducted Emissions.....	108
Radiated Power Frequency Magnetic Field.....	108
ESD Effects.....	108
Surge Withstand – Oscillatory.....	108
Electrical Fast Transient/Burst Immunity.....	108
Surge Immunity.....	108
LVD.....	108
21 SPARE PARTS LIST	109
Alarm Card Spares.....	109
Common Card Spares.....	109
Power Supply Spares.....	110
LED Spares.....	110
22 SERVICING	111

<i>Module Removal</i>	111
.....	111
23 CONTACT	112
<i>Procedures for Factory Repair and Return Warranty</i>	112

1 Annunciator Model Code Definition

Code	Description
	<u>Model No</u>
SMA	SmartAlarm
	<u>Alarm Ways</u>
08	08 Way
16	16 Way
24	24 Way
	<u>Individual Channel Repeat Relays</u>
X	No Individual Channel Repeat Relays Fitted
R	Individual Channel Repeat Relay Fitted
	<u>Primary Supply – Internal PSU-1</u>
A	Universal Input 85-264VAC & 88-300VDC
	<i>OR as an option which must be specified at time of order</i>
D	19-72VDC (Must Be Specified At Time Of Order)
	<u>Aux Supply – Internal PSU-2 (Future)</u>
X	Not Fitted
A	Universal Input 85-264VAC or 88-300VDC
	<i>OR as an option which must be specified at time of order</i>
D	19-72VDC (Must Be Specified At Time Of Order)
	<u>Field Contact (Signal Supply) Internal / External</u>
A	Internally Generated 24VDC / Ext Supplied 24VDC & 125VAC/DC
B	Internally Generated 24VDC / Ext Supplied 48VDC & 250VACVDC
	<u>LED Colour</u>
R	Red
Y	Yellow
G	Green
B	Blue
W	White
I	Intermixed
	<u>Communications</u>
X	Not Fitted
S	RS485 Serial Communications Fitted

<i>Code</i>	<i>Description</i>
	<u>Tropicalisation</u>
X	<i>Not Fitted</i>
C	<i>Tropicalised</i>
	<u>IP Rating</u>
4	<i>IP40 Rated</i>
5	<i>Optional IP54</i>
	<u>Special Options</u>
X	<i>Not Fitted</i>

2 - INTRODUCTION

2.1 General

The SmartAlarm is a panel mounting alarm annunciator used to inform the operator that a process has gone beyond set limits using visual and audible alarms.

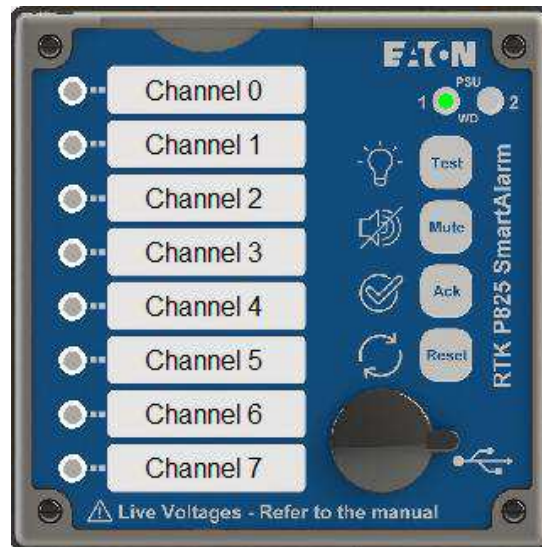

The system comprises the following key elements

- 1 x Face plate.
- Laser printed film legend sheet/sheets.
- 1 x DIN sized flush mounting cabinet.
- 1 x Rear mounting motherboard complete with customer terminals.
- 1 x Common Services Card.
- ** x 8 Channel alarm card / cards (** qty depends on annunciator size).

Available Versions

8, 16 or 24 Way versions are available using industry standard DIN Size enclosures.

Card Locations

Four screws are provided on the face plate of the annunciator to allow access to the internal cards.

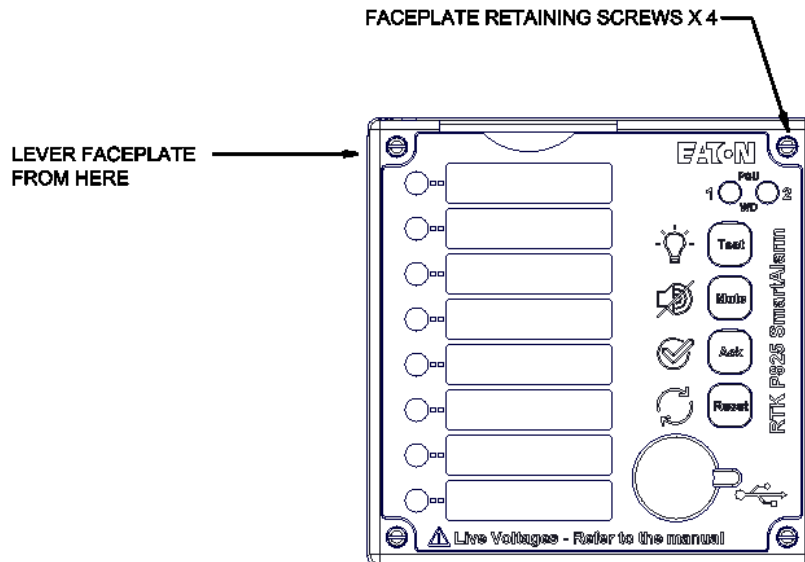

Once the Faceplate has been removed access is available to the two types of card used within the SmartAlarm.

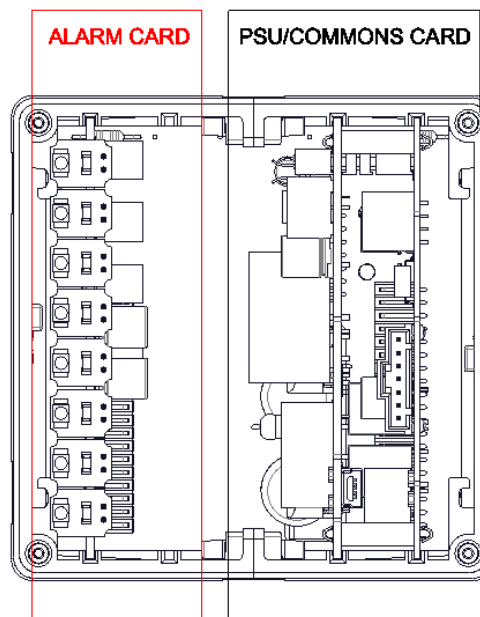

WARNING

WARNING !

Hazardous voltages may exist on exposed internal components and exposed rear terminals. Take care not to touch any exposed parts

2.1.1 PSU/Common Services Card

- The PSU/Common Services Card is located in the right hand card slot of the enclosure, (Position 0), when viewed from the front.
- As PSU/Common Service cards can be powered from 85-263VAC 50/60 Hz or 88 to 300VDC for safety reasons please ensure the supply is fully isolated before removing the associated card.
- Single and Dual redundant power supply options are available providing secure power to the panel. For further information please see pages 17 and 18

2.1.2 Alarm Cards (8 Channel)

- Alarm cards are located to the left of the PSU/Common Service card.
- On 16 and 24 way versions multiple alarm cards are used.
- The alarm cards are interchangeable however as the associated configuration settings are stored on the individual cards if a card is placed in the incorrect slot the setting may not match the monitored process.
- The PSU/Common Services card and Alarm card are polarised to prevent insertion into the incorrect card slot.

2.1.3 Pluggable LED's

Each channel is illuminated by a pluggable LED located on the front of each 8 channel alarm card.

The LED assembly is held in place by 2 pins and the assembly can be removed by pulling gently towards you.

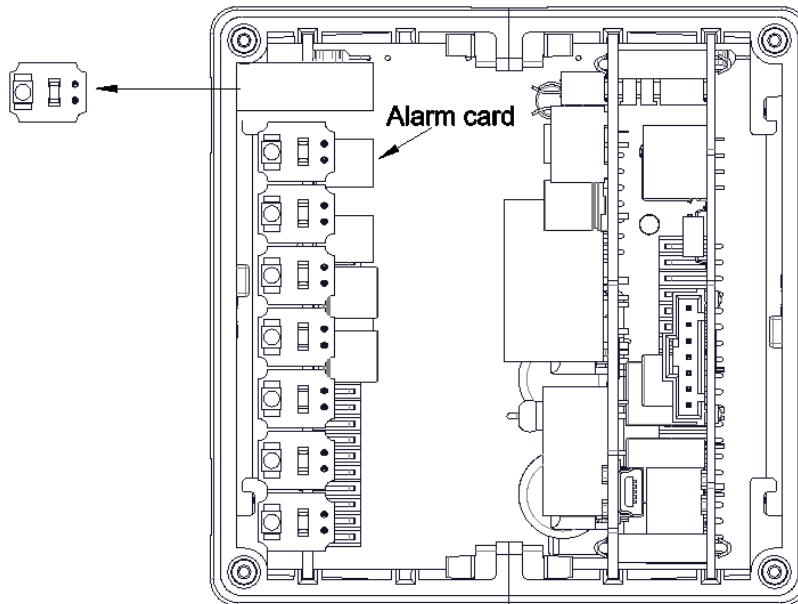

LED assemblies are available in the following colours:-

- White(WT).
- Red(RD).
- Yellow(YW).
- Green(GN).
- Blue(BL).
- Intermixed(I). (Specify colour required per channel).

 <p>WARNING</p>	<p>WARNING !</p> <p>Hazardous voltages may exist on the LED assembly connections accessed via the front panel. Take care and use insulated tools to remove and replace LED assemblies</p>
---	--

2.1.4 Input Isolation

All signal inputs are optically isolated for use in harsh electrical environments.

2.1.5 Bi-Polar Inputs

125v and 250v signal inputs are bi-polar and therefore capable of accepting AC or DC voltages. 24 V and 48V are DC input only

2.1.6 Standard Input Version

The standard version uses a fully isolated +24VDC supply as a signal voltage, (fused at 160mA), which can be fed via a normally open (N/O) or normally closed (N/C) field contact to trigger each alarm as required.

2.1.7 Optional Powered Input Versions

As an alternative Customer powered Inputs can be used:-

- Option A = 24VDC & 125VAC/DC or
- Option B = 48VDC & 250VAC/DC.

The signal supply voltage level must be specified at the time of order to ensure the correct type alarm card is supplied.

2.1.8 Integral Pushbuttons

Four Integral tactile pushbuttons are provided as standard designated as Test, Mute, Ack, (Acknowledge), and Reset.

2.1.9 Customer Terminals

Industry standard rising clamp terminals capable of accepting up to 2.5mm² cable are provided for customer use on the rear of the annunciator and each terminal is held in place by retaining screws located at the top and bottom of each terminal block for additional security.

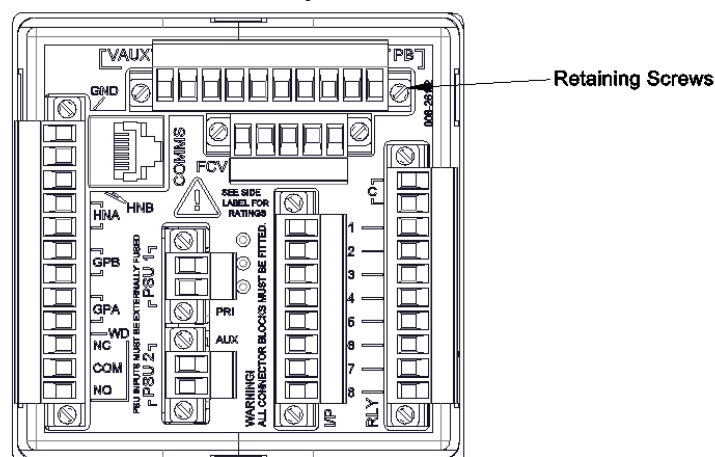

WARNING !
Hazardous voltages may exist on the rear panel connections when connectors are removed. Take care not to touch any exposed parts

2.1.10 Terminals For Use With External Pushbutton Inputs

Five additional optically coupled inputs, PB1 to PB5, are available on the rear of the annunciator for use with external pushbuttons, group inhibit or a sleep mode switch as required.

The common return for the remote inputs is PCom

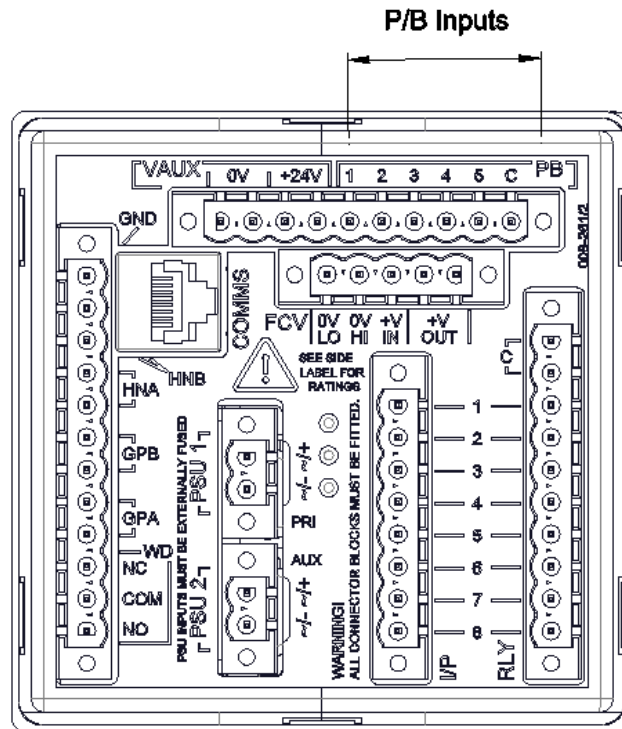

Please note: VAUX +24V can be used for external pushbuttons, or any nominal 24V terminal on the rear panel.

 <p>WARNING</p>	<p align="center">WARNING !</p> <p align="center">Hazardous voltages may be present when the front panel is removed. Take care not to touch any exposed parts on within the annunciator beyond those specified in the instructions below.</p>
---	--

2.1.11 Internal Audible Alarm

An integrally mounted 2.4Khz speaker is located on the common services card.

To adjust to volume use the slider in the SmartAlarm configurator as shown below.

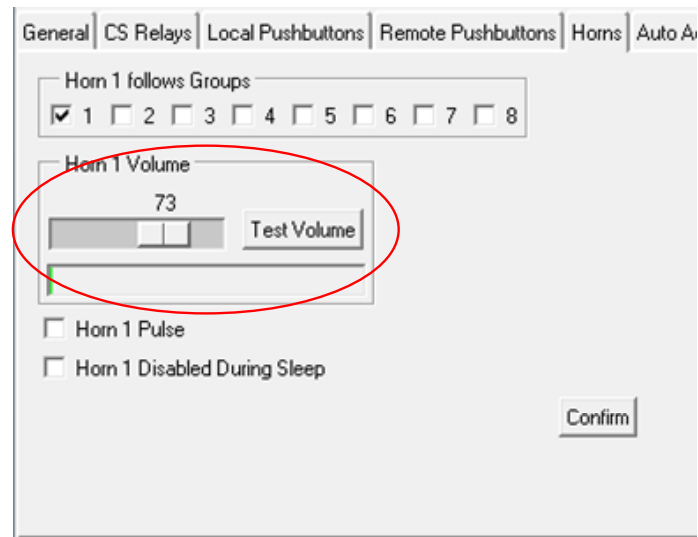

2.1.12 HNA & HNB Horn Relays

Common Relay – HNA & HNB are used as Horn Relays and the following options are software selectable:-

- Any channel within the annunciator can be set to operate either relay as required.
- The relay coil state can be set to Normally Energised or Normally De-Energised.
- The relay can be disabled to prevent it operating on System Test.
- The relay can be disabled to prevent it operating during Sleep Mode.
- Relay mode is set to horn as default but can be modified to other modes using the configuration software.

2.1.13 GPA & GPB Common Alarm Group Relays

Common Relay – GPA & GPB are used as Group Relays and the following options are software selectable:-

- Any channel within the annunciator can be set to a common alarm group.
- The group function can be set to “alarm” which keeps the signal active until the alarm has been cleared.
- Any “alarm” group within the annunciator can be linked to either relay as required.
- A reflash function can be selected per group which allows the contacts to revert to normal and re-alarm each time a new alarm occurs within the same group. The reflash pulse duration can be set between 1mS and 65,000mS.
- The relay state can be set to Normally Open or Normally Closed.
- The relay can be disabled to prevent it operating on System Test.
- The relay can be disabled to prevent it operating during Sleep Mode.
- Relay mode is set to group as default but can be modified to other modes using the configuration software.

2.1.14 WD Watchdog Relay

A Watchdog Relay is available as standard to provide a signal to a 3rd party device to indicate a fault has been detected within the annunciator. The following options can be configured in software.

- All faults.
- Field contact fault.
- System fault.
- Comm's fault.
- Card fault.
- LED fault.
- Power fault.

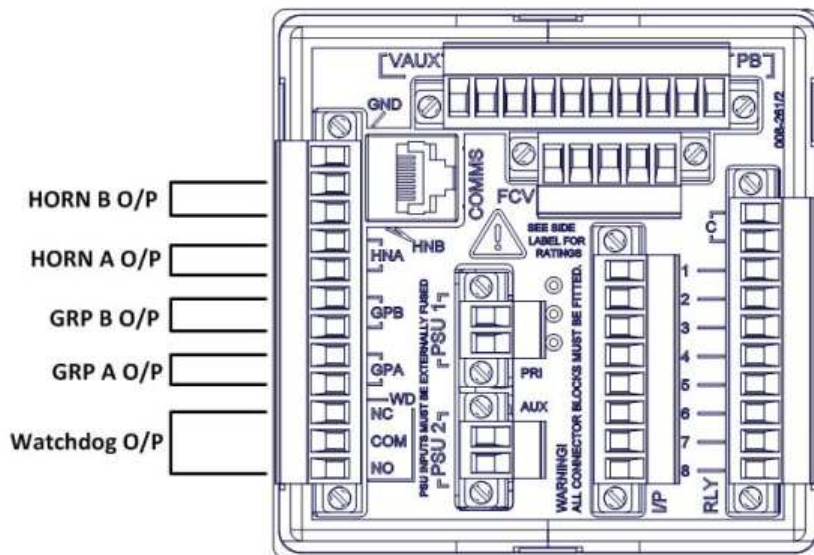

Typical Volt Free Relay Contact Outputs

 <p>WARNING</p>	<p>WARNING !</p> <p>Hazardous voltages may exist on the rear panel connections when connectors are removed. Take care not to touch any exposed parts</p>
--	---

2.1.15 Watchdog Monitoring LED's

As alarm annunciators are used in safety critical applications it is important that the functions of the annunciator are monitored and the SmartAlarm is equipped with an extensive self-diagnostic facility including two green status LED's, in standard mode they provide dynamic monitoring of the logic supply, field contact supply, and system status. In diagnostic / program mode the LED's allow real time contact status monitoring, manual input type programming and communications Tx & Rx monitoring.

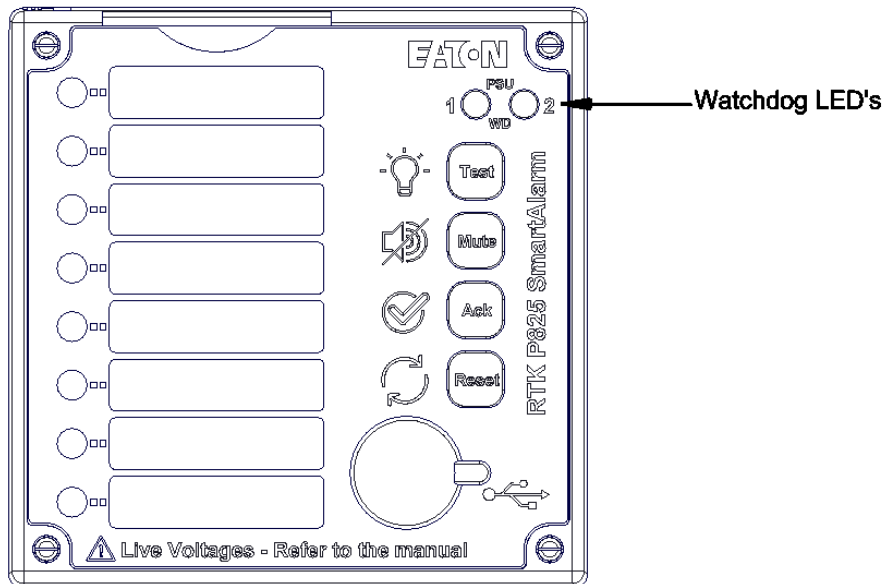

	Condition	LED1	LED2
Start Mode	Wait config message		
Normal Mode	No faults, PSU1 only fitted	ON	OFF
	No faults, PSU1+2 fitted	ON	ON
	Test button pressed	ON	ON
	FCV fail	Vfast_Flash	ON
	VAUX fail	ON	Vfast_Flash
	PSU1 fail	Slow_Flash	ON
	PSU2 fail	ON	Slow_Flash
	COMS fail Other system fail	Vfast_Flash	Vfast_Flash
Configuration Mode		Slow_Flash	OFF
Diagnostic/Program Mode		OFF	Slow_Flash
Diagnostic/Comms Mode	No comms	OFF	OFF
	TX/RX comms	ON/OFF	ON/OFF

2.1.16 Diagnostic / Program mode - Dynamic Contact Status

The internal pushbuttons can be used to view the dynamic state of all signal inputs by pressing and holding the internal **Test** pushbutton for 10 seconds.

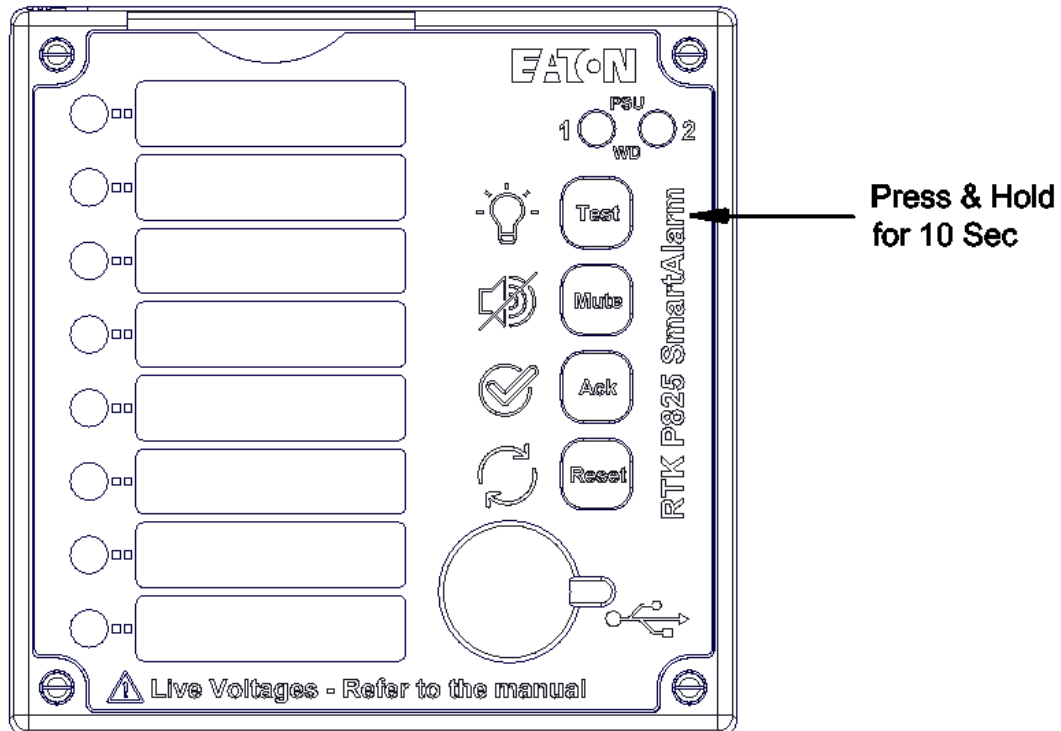

LED-1, located above the test pushbutton, slow flashes to indicate the Annunciator is in monitor mode.

Whilst in this mode the individual channel LED provides the dynamic status of the associated field contacts.

- If the LED is ON the field contact is CLOSED.
- If the LED is OFF the field contact is OPEN.

This is a quick method of verifying the dynamic state of the field contact and is typically used during commissioning or fault finding.

The contact monitoring function times out after 1 minute and the unit automatically returns to the normal run mode and LED-1 reverts to steady ON.

2.1.17 Diagnostic / Program mode - Manually changing the input type

The internal pushbuttons can be used to change the input state for each channel from normally open (N/O) to normally closed (N/C) by pressing and holding the internal **Test** pushbutton for 10 seconds.

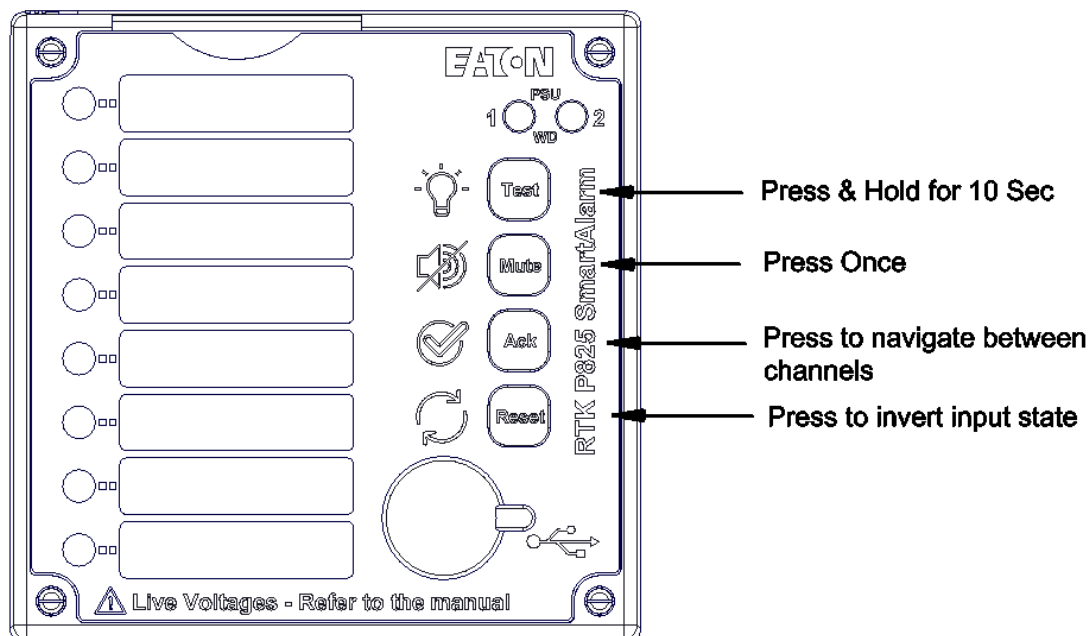

LED-1, located above the test pushbutton, slow flashes to indicate the Annunciator is in the monitor mode.

Press the **Mute** pushbutton once and note LED-2 and Channel-1 LED slow flash to indicate that you are now able to invert the state of Channel-1 as required.

Pressing the **Ack.** pushbutton navigates to the next channel in sequence and once the last channel has been configured the cycle repeats.

Pressing the **Reset** pushbutton toggles between N/O or N/C

Note: As you navigate away from each channel .

- If the LED remains ON the input is set to normally closed .
- If the LED is OFF the input is set to normally open .

The “input state function” times out and the unit automatically returns to the normal run mode after 1 minute and LED-1 reverts to steady ON.

2.1.18 Diagnostic / Program mode - Communication Monitoring

The internal pushbuttons can be used to monitor communication activity between the SmartAlarm and 3rd Party devices by pressing and holding the internal **Test** pushbutton for 10 seconds.

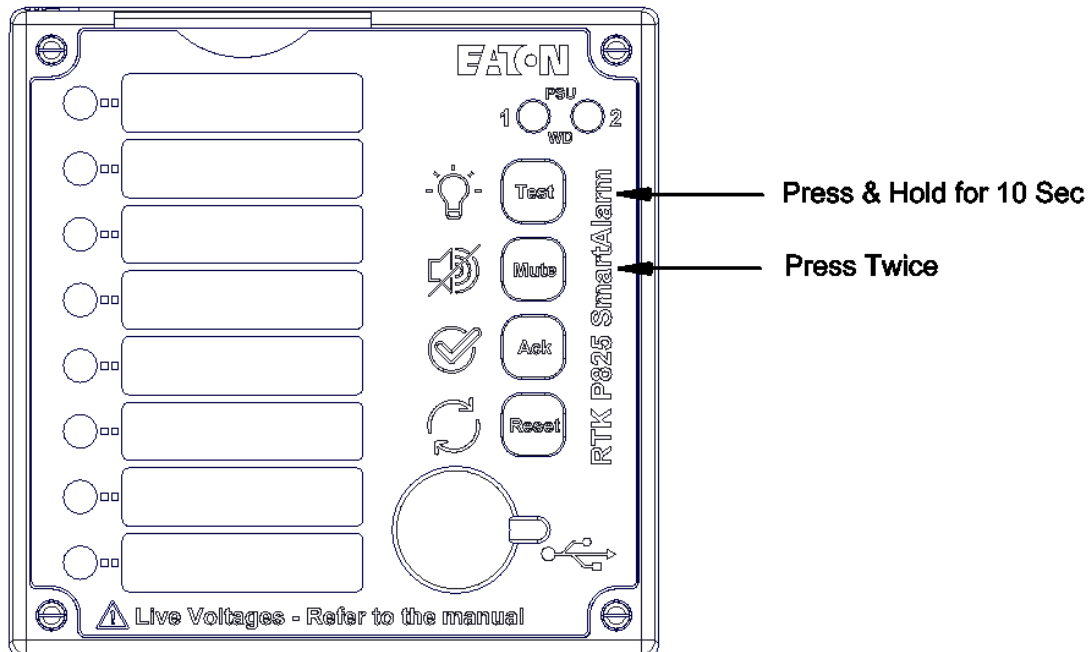

LED-1, located above the test pushbutton, slow flashes to indicate the Annunciator is in monitor mode.

Press the **Mute** pushbutton twice and note LED-1 and LED-2 go OFF and then act as Rx & Tx for communication between devices.

The communication monitoring function times out and the unit automatically returns to the normal run mode after 1 minute and LED-1 reverts to steady ON.

 WARNING	WARNING ! Installation, configuration and maintenance of this annunciator must only be performed by competent service personnel
--	---

 WARNING	WARNING ! Hazardous voltages may exist on the LED assembly connections accessed via the front panel. Take care and use insulated tools to remove and replace LED assemblies
--	---

2.1.19 Programmable Features

The SmartAlarm is equipped with a host of customer selectable features which can be accessed via a USB Mini-B programming port located behind a rubber bung on the face of the annunciator.

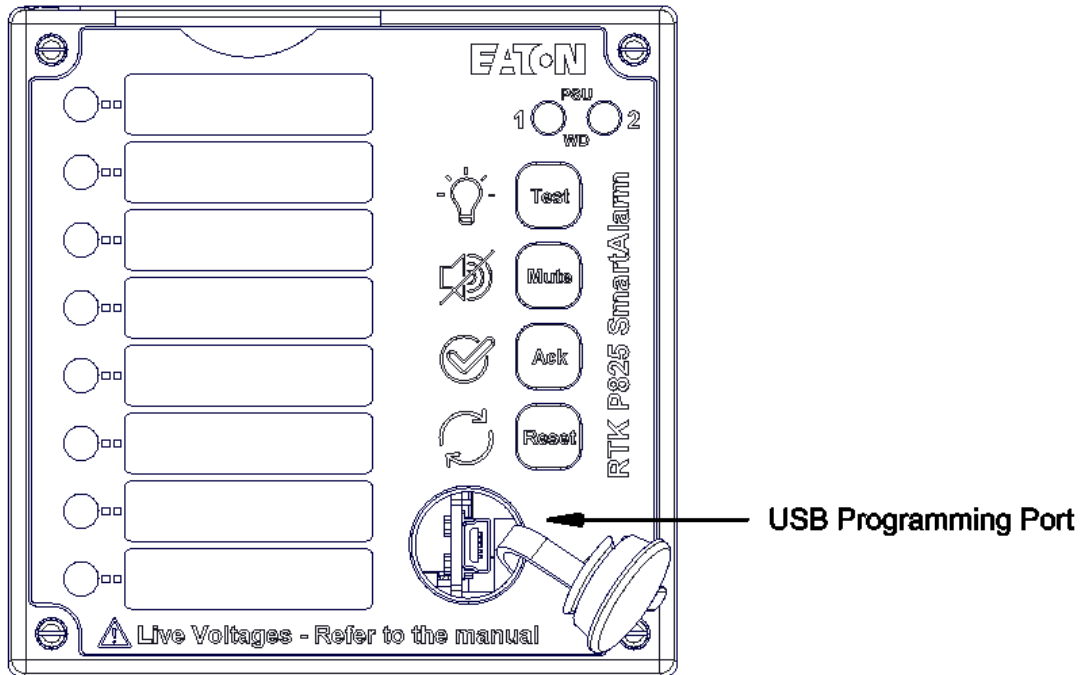

Once connected to a PC running the Eaton supplied configuration software the user can enable or disable pre-defined functions as required.

Selection of features is on a per channel basis with no special tools or programming knowledge required.

	WARNING !
WARNING	Hazardous voltages may be present when the front panel bung is removed. Take care not to touch any exposed parts on within the annunciator beyond those specified in the instructions below.

2.1.20 Film Legends

Laser printed alarm legends are used within the SmartAlarm allowing the Customer to easily change the legends on site as required.

Film legends can be created in a style, size, font and language using Microsoft Excel and Eaton can provide a blank Microsoft Excel template locked to the correct size viewing area if requested.

Once the legend details have been entered into the excel spreadsheet they can be laser printed onto A4 overhead transparency film, or paper.

Each set of 8 legends can be inserted via the top of the face plate using the ½ circle indent to install the acetate sheet behind the face plate as shown below.

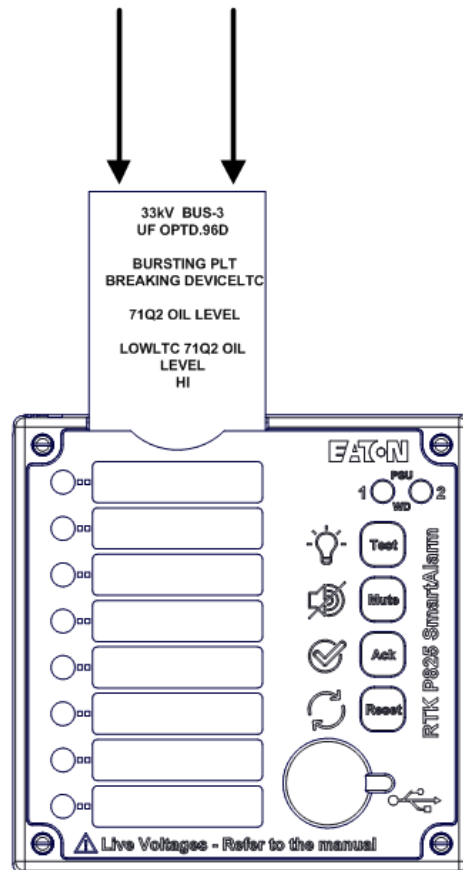

2.1.21 Window Numbering System

Eaton/RTK have adopted the following window numbering system to aid with the location of the film legend and the associated alarm cards.

This method is used to ensure that the legend matches the functions selected for the designated alarm.

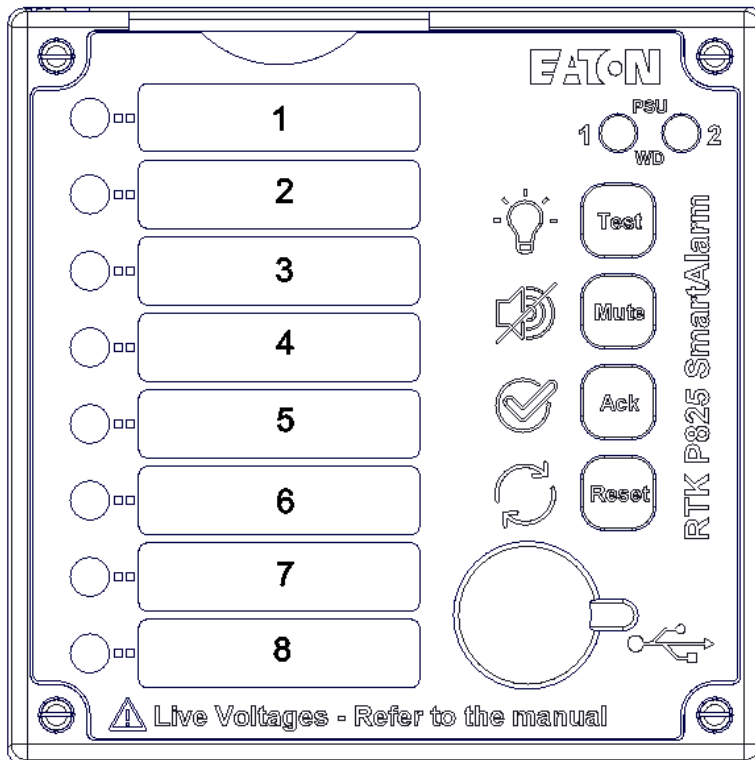

2.1.22 USB Programming Port

A rubber bung is used to maintain the IP rating of the annunciator and this can be unplugged to access the USB programming port.

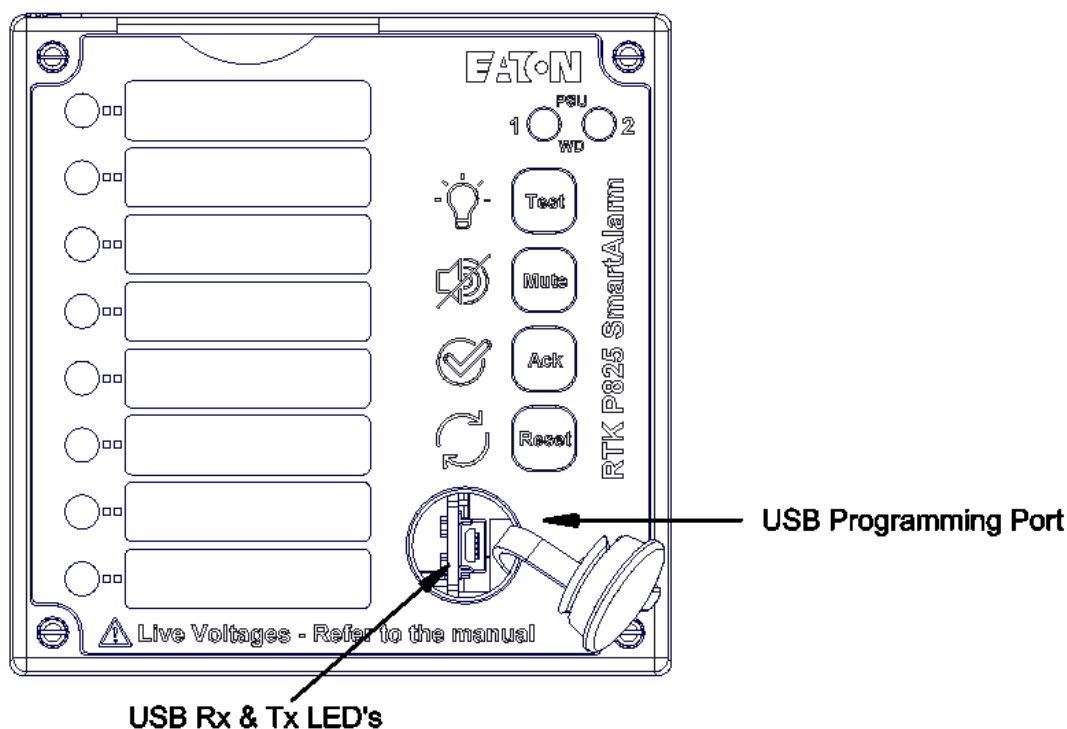

The USB Port is used to:-

1. Upload a configuration from an existing SmartAlarm.
2. Download a configuration to the SmartAlarm.
3. View diagnostic data whilst fault finding.

Once the user connects the Eaton supplied USB cable between a PC/Laptop and the USB programming port USB LED's located just inside the face plate aperture indicate data exchange.

Full details of programming are provided in later sections of this manual.

 <p>WARNING</p>	<p>WARNING !</p> <p>Hazardous voltages may be present when the front panel bung is removed. Take care not to touch any exposed parts on within the annunciator beyond those specified in the instructions below.</p>
---	---

3 PRIMARY POWER

Primary Power – PS1

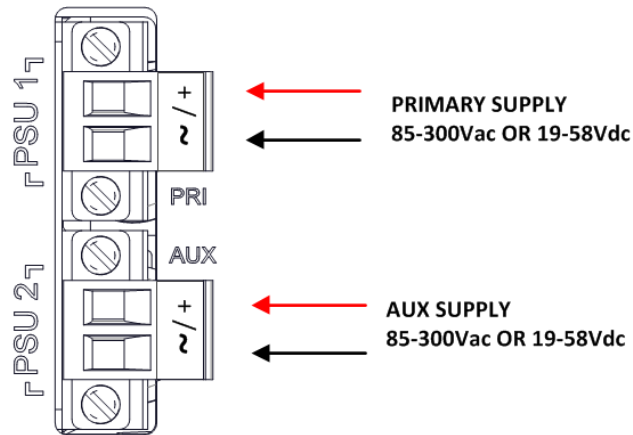

- Primary power is connected to terminal **Primary** - PS1 – (\sim +VE) and (\sim -VE) as indicated above.
- On the standard version the supply input is universal capable of accepting 85-264VAC 50/60 Hz or 88 to 300VDC.
- As an option, which must be specified at the time of order, the primary supply can be 19-72VDC.
- A watchdog relay, WD, is fitted as standard providing a volt free changeover contact for use with 3rd party devices to indicate loss or primary power or internal failure.
- All PSU's need to be protected with an external fuse rated at 1AT or equivalent MCB

CAUTION

Power supplies must be fused externally with a 1AT fuse or suitable MCB.



WARNING !

Hazardous voltages may exist on the rear panel connections when connectors are removed. Take care not to touch any exposed parts and isolate the supply before carrying out any work.



WARNING !

GPA, GPB, WD, Channel Repeat Relays should only be connected to customer secondary circuits separated from mains supply circuits by means of a transformer. For hazardous voltage above 60Vdc (SELV) isolate the supply before carrying out any work

3 AUX POWER

Aux Power – PS2

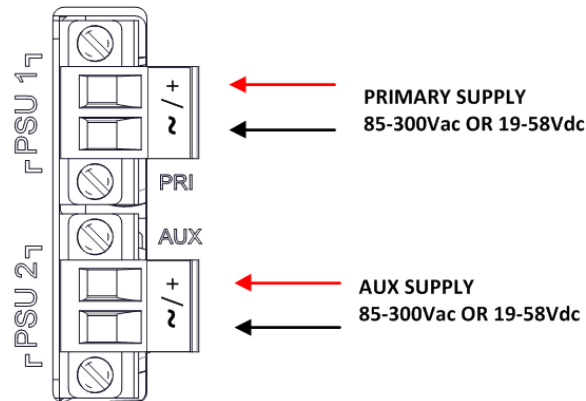

- Aux power is connected to terminal **AUX** - PS2 - (\sim +VE) and (\sim -VE) as indicated above.
- On the standard version the supply input is universal capable of accepting 85-264VAC 50/60 Hz or 88 to 300VDC.
- As an option, which must be specified at the time of order, the aux supply can be 19-72VDC.
- A watchdog relay, WD, is fitted as standard providing a volt free changeover contact for use with 3rd party devices to indicate loss or primary power or internal failure.
- All PSU's need to be protected with an external fuse rated at 1AT or equivalent MCB

CAUTION

Power supplies must be fused externally with a 1AT fuse or suitable MCB.



WARNING

WARNING !

Hazardous voltages may exist on the rear panel connections when connectors are removed. Take care not to touch any exposed parts and isolate the supply before carrying out any work.



WARNING

WARNING !

GPA, GPB, WD, Channel Repeat Relays should only be connected to customer secondary circuits separated from mains supply circuits by means of a transformer. For hazardous voltage above 60Vdc (SELV) isolate the supply before carrying out any work

4 – SIGNAL INPUT TYPES

Internally Powered 24VDC Signal Inputs

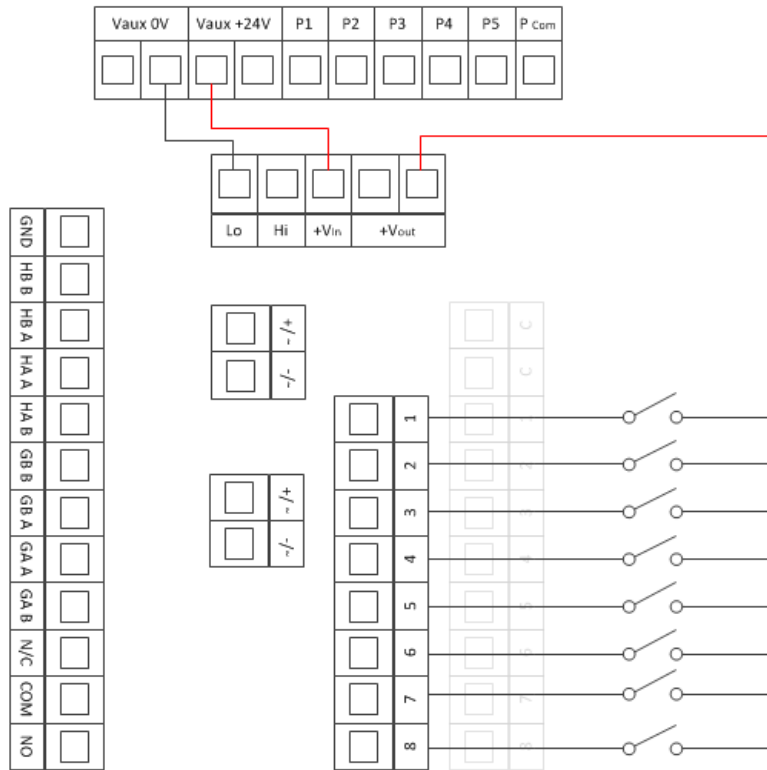



- On standard SmartAlarm annunciators a fully isolated +24VDC supply is provided for use as a signal supply voltage.
- This output is available on all +VFC terminals which are internally linked and protected by fuse.
- An internal 160mA glass quick blow fuse, 5mm x 20mm, located on the Common Services Card is used to protect the output from field wiring errors.

Signal Supply Fuse Location (FCV)

This is located on the Commons services card

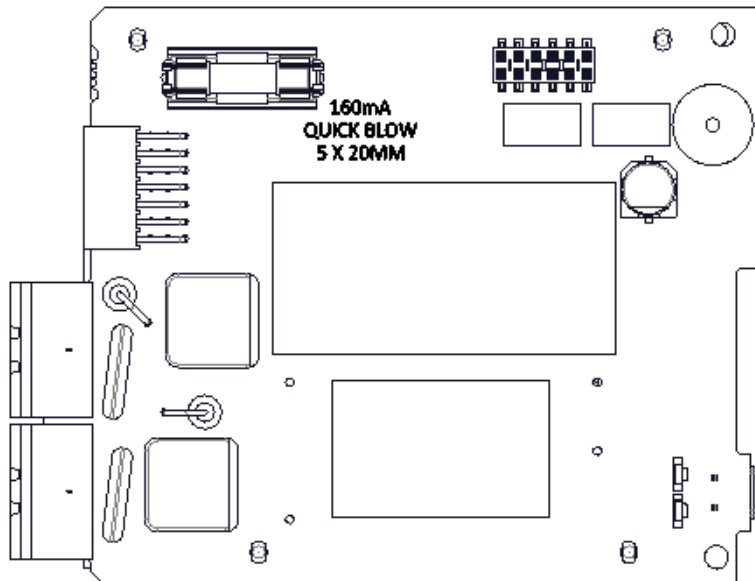
- A 160mA quick blow glass fuse 5 x 20mm is located on the PSU Card to protect the signal supply voltage (FCV).



 WARNING	<p style="text-align: center;">WARNING !</p> <p style="text-align: center;">Installation, configuration and maintenance of this annunciator must only be performed by competent service personnel</p>
--	--

 WARNING	<p style="text-align: center;">WARNING !</p> <p style="text-align: center;">Hazardous voltages may exist on the rear panel connections when connectors are removed. Take care not to touch any exposed parts and isolate the supply before carrying out any work.</p>
--	--

24 or 48 VDC/ Customer Powered Inputs

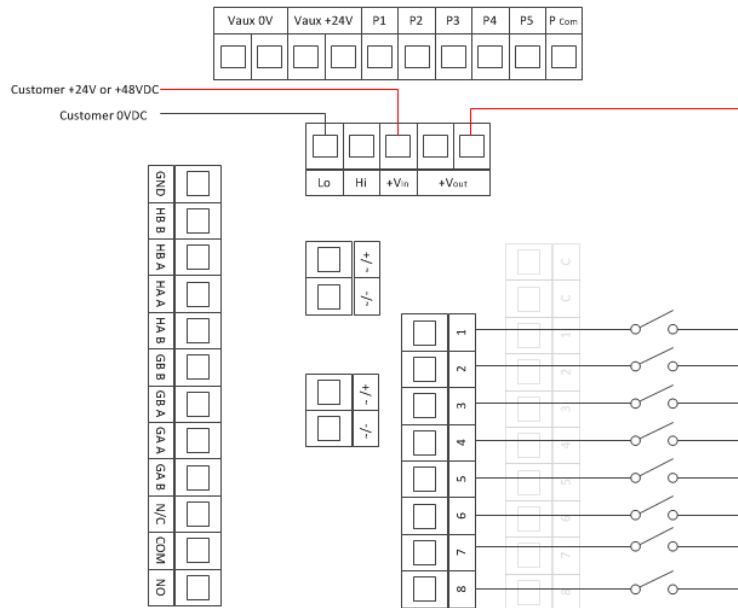

Alternative Connection Method

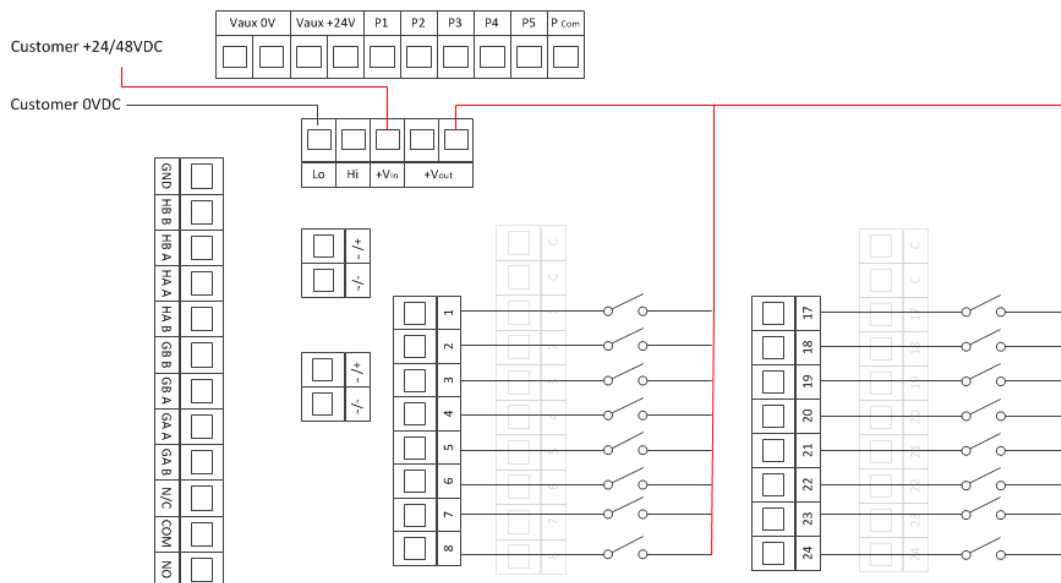

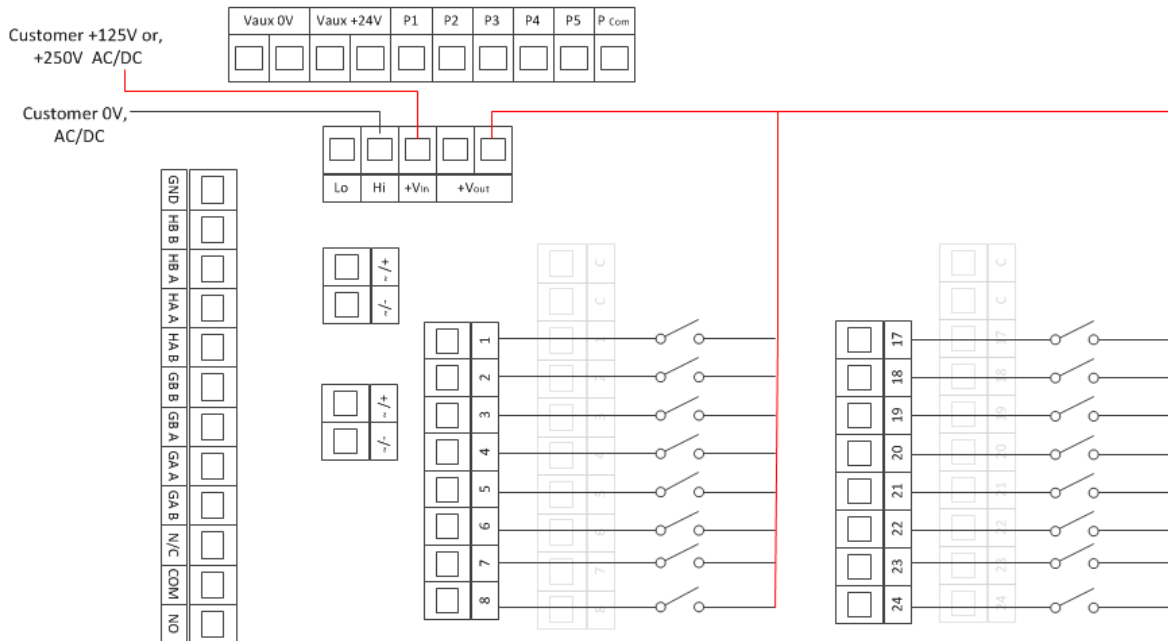

- If the Customer is providing a signal supply voltage in the range 24/48/VDC this supply is connected to terminal VFC (+ VIN) and (OVLO). If 24VDC or 48VDC Customer Powered Inputs are required this must be specified at the time of order as unique alarm cards are used for each version.
- Once the supply has been connected the signal supply voltage is internally distributed to the signal common terminal VFC for distribution to the field contacts. An internal 160mA glass quick blow fuse, 5mm x 20mm, located on the Common Services Card is used to protect the output from field wiring errors. If external customer supply is used then a suitable fuse should be fitted

125VDC/AC or 250VDC/AC Customer Powered Inputs



- If the Customer is providing the signal supply voltage of 125VAC/DC or 250VAC/DC this supply is connected to terminal VFC (+VIN) and (OVHI). If 125VAC/DC or 250VAC/DC Signal Inputs are required this must be specified at the time of order as unique alarm cards are used for each version.

 <p>WARNING</p>	<p align="center">WARNING !</p> <p align="center">Hazardous voltages may exist on the rear panel connections when connectors are removed. Take care not to touch any exposed parts and isolate the supply before carrying out any work.</p>
 <p>WARNING</p>	<p align="center">WARNING !</p> <p align="center">For hazardous voltage above 60Vdc (SELV) isolate the supply before carrying out any work</p>

125VDC/AC or 250VDC/AC Alternative Connection Method

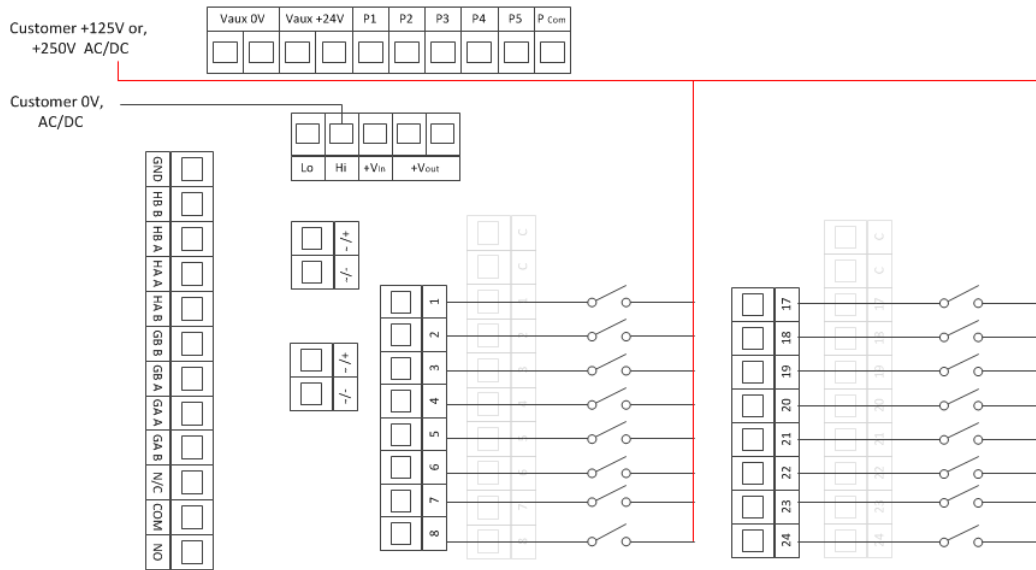

- Once the supply has been connected the signal supply voltage is internally distributed to the signal common terminal +VFC for distribution to the field contacts. An internal 160mA glass quick blow fuse, 5mm x 20mm, located on the PSU Card is used to protect the output from field wiring errors. If external customer supply is used then a suitable fuse should be fitted
-

 WARNING	WARNING ! Hazardous voltages may exist on the rear panel connections when connectors are removed. Take care not to touch any exposed parts and isolate the supply before carrying out any work.
---	---

 WARNING	WARNING ! For hazardous voltage above 60Vdc (SELV) isolate the supply before carrying out any work
---	--

5 HORN RELAYS

HNA & HNB Horn Relays

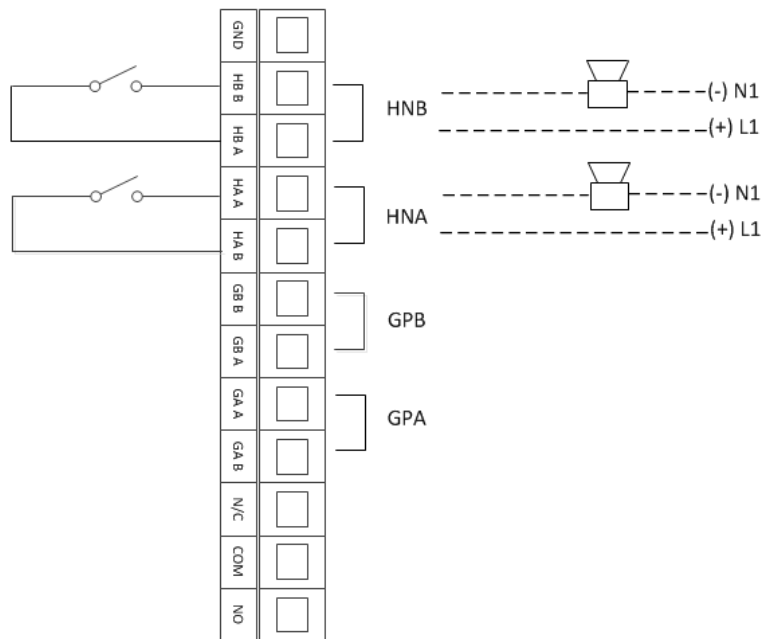

- Two horn relays are provided as standard HNA & HNB.
- Any channel within the annunciator can be software configured to operate the HNA or HNB relay as required.
- A volt free contact is available from each relay to switch an external audible or 3rd party device.
- The relay is normally de-energised providing a N/O contact to activate the horn when an alarm occurs.
- Contact rating 4A 24VDC (2A 120VAC).
- If horn relays are not required the relays can be software selected to an alternative function. (Group Relay, Pushbutton Follower, Watchdog Function)

 <p>WARNING</p>	<p style="text-align: center;">WARNING !</p> <p>Hazardous voltages may exist on the rear panel connections when connectors are removed. Take care not to touch any exposed parts</p>
---	---

6 COMMON ALARM GROUP RELAYS

GPA & GPB Group Relays

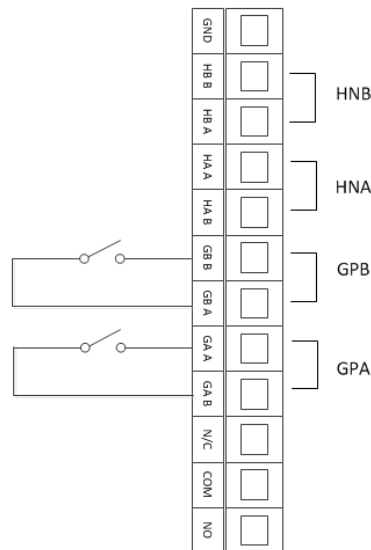

- Two common alarm group relays are provided as standard GPA & GPB.
- Any channel within the annunciator can be software configured to operate the GPA or GPB relay as required.
- A volt free contact is available from each relay for use with 3rd party devices.
- The Contact is configurable to N/O or N/C.
- Contact rating 1A 24VDC (0.5A 120VAC)
- A reflash function can be used to interrupt the common alarm contacts each time a new alarm in the group occurs.
- If Group Relays are not required the relays can be software selected to an alternative function. (Horn Relay, Pushbutton Follower, Watchdog Function)

 WARNING	WARNING !
	GPA, GPB, WD, Channel Repeat Relays should only be connected to customer secondary circuits separated from mains supply circuits by means of a transformer. For hazardous voltage above 60Vdc (SELV) isolate the supply before carrying out any work

7 REMOTE PUSHBUTTON INPUTS

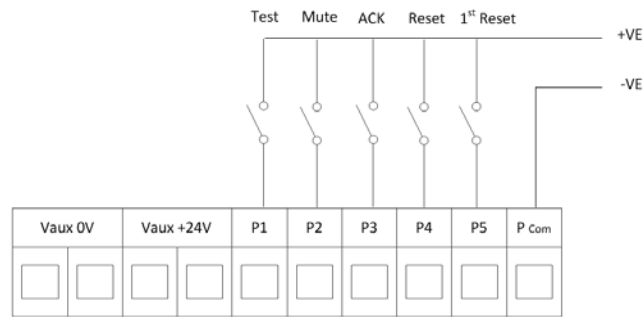

- Five optically coupled digital inputs are provided as standard for use with external N/O momentary pushbuttons.

Pushbutton Functions

- PB1 = System Test.
- PB2 = Mute.
- PB3 = Acknowledge.
- PB4 = Manual Reset.
- PB5 = First Reset.
- PCom= supply Return*

The above functions can be changed in software if required .

***CAUTION**

The Pushbutton inputs are designed for bipolar operation at 24VDC as provided by the VAUX terminals. This is separate from Field Contact Voltage (FCV) selected for the alarm inputs. Customer 24VDC external supply can be used, but must be suitable protected by a fuse or MCB

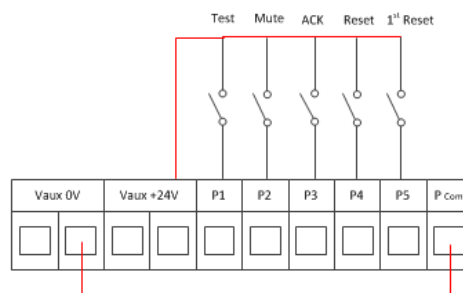

WARNING

WARNING !

For hazardous voltage above 60Vdc (SELV) isolate the supply before carrying out any work

Group Inhibit Function

As an option any of the remote pushbutton inputs, PB1 to PB5, can be software configured to change their use to a group inhibit function.

Any alarm can be assigned to a inhibit group and an external switch can be used to inhibit the alarms in the group during prolonged maintenance periods to prevent nuisance alarms.

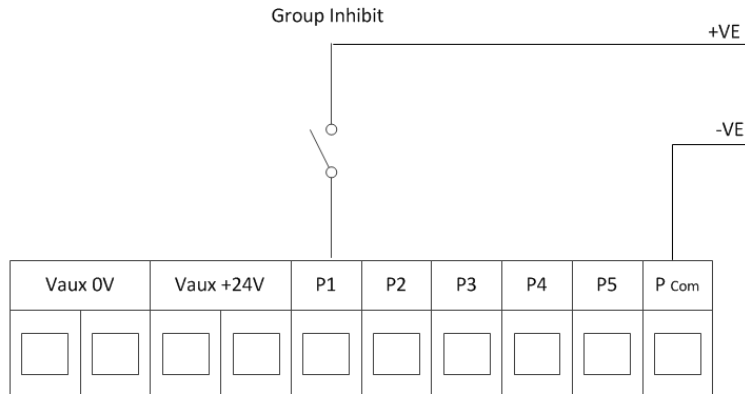

The above example shows the PB1 input being used with a remote group inhibit switch. PB1 must be software configured to “Inhibit” for the function to work and individual channels must be software configured to the inhibit group.

CAUTION

The pushbutton terminals are designed for 24VDC operation only. If the selected *Alarm Input* voltage is different to +24VDC. E.G. 48VDC, 125VAC/DC or 250VAC/DC please note that VAUX 0V & +24VDC has to be used, or a suitably protected external 24VDC source.

***CAUTION**

The Pushbutton inputs are designed for bipolar operation at 24VDC as provided by the VAUX terminals. This is separate from Field Contact Voltage (FCV) selected for the alarm inputs. Customer 24VDC external supply can be used, but must be suitable protected by a fuse or MCB



WARNING

WARNING !

For hazardous voltage above 60Vdc (SELV) isolate the supply before carrying out any work

Sleep Mode Function

Sleep Mode is used in applications where the installation is not manned 100% of the time. During unmanned periods the annunciator can be placed in the unattended mode which disables the alarm LED's and Audible alarms to save power and prevent noise pollution.

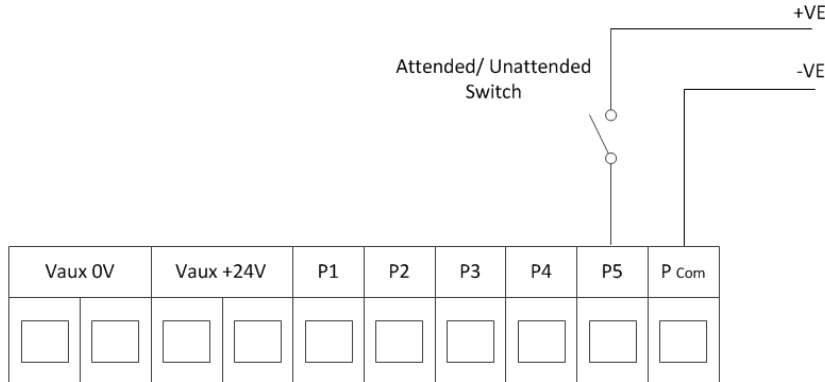

The above example shows PB1 input software configured for use with a remote Attended / Unattended switch. PB1 must be software configured to “Sleep” for the function to work.

When “Sleep Mode” is activated, by maintaining the switch in the closed position, the alarm LED's and audibles will be disabled to save power and reduce noise pollution during unmanned periods. Alarms will still be captured in the normal way and once the switch is returned to the attended position, (open), the annunciator will function as normal.

Whilst in sleep mode the alarm LED's pulse in unison periodically to indicate that the annunciator is in sleep mode. The pulse can be disabled in software under the “General” Tab by selecting the check box “Sleep Without Indication” followed by “Confirm” . The SmartAlarm can be updated using the Tools menu “Send Settings” to download the changes.

*CAUTION

The Pushbutton inputs are designed for bipolar operation at 24VDC as provided by the VAUX terminals. This is separate from Field Contact Voltage (FCV) selected for the alarm inputs. Customer 24VDC external supply can be used, but must be suitable protected by a fuse of MCB



WARNING !

For hazardous voltage above 60Vdc (SELV) isolate the supply before carrying out any work

8 INDIVIDUAL CHANNEL REPEAT RELAYS

As an option a low power magnetically latched pulse relay can be provided on a per channel basis to repeat the alarm signal to 3rd party devices.

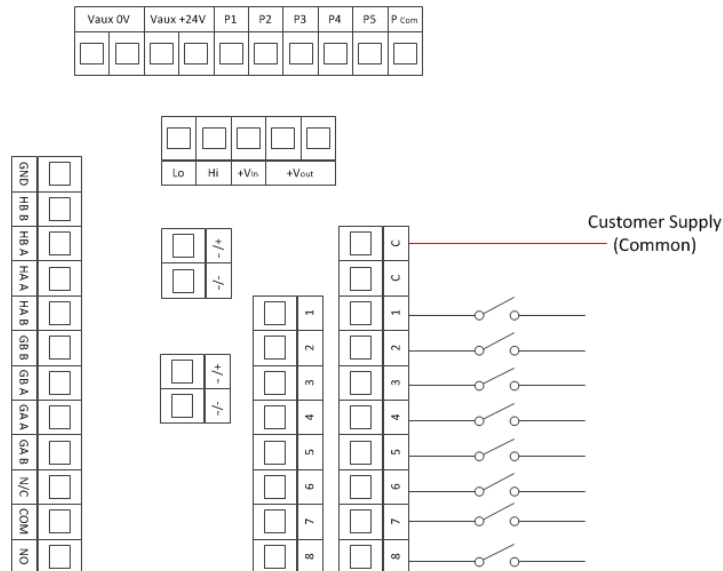

Each relay can be configured in software to operate in accordance with one of the following:-

Input Follower

The relay changes state each time there is a change to the associated signal input contact.

Logic Follower

The relay changes state on alarm and remains in the abnormal state until the input has returned to normal and the logic has been reset using the pushbuttons associated with the ISA sequence set for this channel.

Display Follower

The relay changes state on alarm and faithfully follows the display window i.e. Flashing, Steady or Off depending on the alarm sequence selected for this channel.

Contact Rating

1A @ 24VDC (0.2A 120VAC)

 WARNING	WARNING ! GPA, GPB, WD, Channel Repeat Relays should only be connected to customer secondary circuits separated from mains supply circuits by means of a transformer. For hazardous voltage above 60Vdc (SELV) isolate the supply before carrying out any work
---	--

9 TYPICAL SMARTALARM REAR VIEW

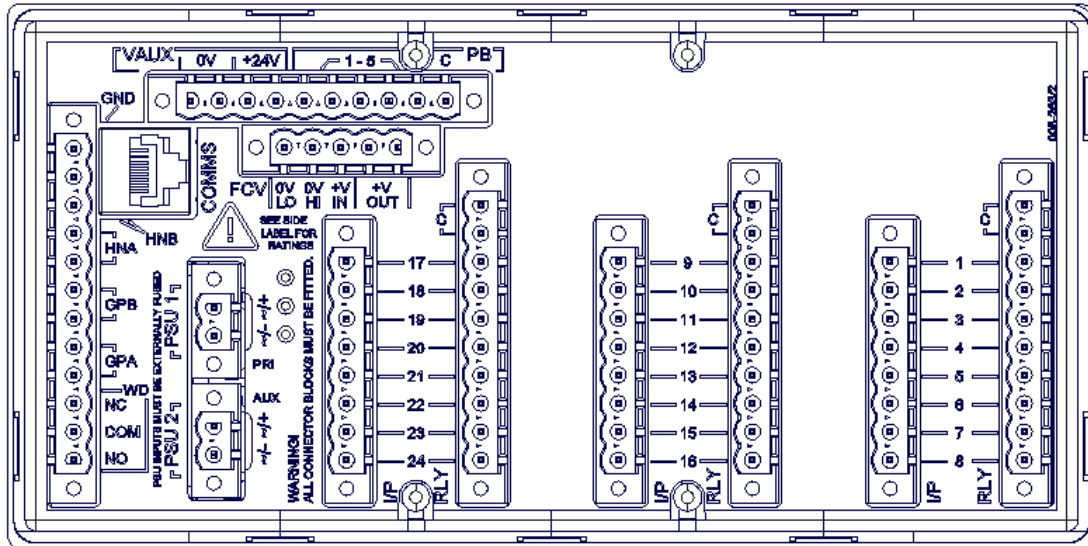

Typical Rear View 16 Way SmartAlarm with repeat relays

10 INSTALLATION

Unpacking

Once the item has been unpacked please visually examine the unit for any signs of transit damage before installing the unit into the control system. If any damage has occurred please report the damage to the freight forwarder and copy Eaton. The alarm annunciator is supplied with panel mounting clamps locked in place, however please check all packages to ensure that no additional pieces are left in the box as any auxiliary items like horns, pushbuttons or spares kits will be packed separately.

Please double check that all items listed on the packing list have been unpacked before disposing of any packing material.

Mounting

SmartAlarm annunciators are designed for panel mounting and therefore a suitable cut-out must be provided to securely locate them using the Eaton panel mounting clamps provided on either side of the annunciator. Each clamp can be tightened using a phillips screwdriver.

Dimensions for panel mounting versions

8 Way

- Overall:- 96mm H x 96mm W x 125mm D
- Cut-Out :- 91 + 0.5mm H x 91 +0.5mm W

16 Way

- Overall:- 96mm H x 144mm W x 125mm D
- Cut-Out:- 91 + 0.5mm H x 139 + 0.5mm W

24 Way

- Overall:- 96mm H x 192mm W x 125mm D
- Cut-Out:- 91 + 0.5mm H x 187 + 0.5mm W

- Maximum radius cut-out 3mm

19" Rack Mounting

SmartAlarms are suitable for mounting within 19" racks using suitable filler plates which can be supplied by Eaton as optional items.

Wall Mounting

Eaton offer a full integration service where panel mounted annunciators are supplied within an industry standard Wall mounting Enclosure, with all customer connections typically wired to Weidmuller terminals for ease of connection to the field device.

Floor Standing

Eaton offer a full integration service where panel mounted annunciators are supplied within an industry standard Floor Standing Enclosures, with all customer connections typically wired to Weidmuller terminals for ease of connection to the field device.

	<p style="text-align: center;">WARNING !</p> <p>This annunciator is designed for panel mounting. The rear portion of the annunciator must be protected by an enclosure that is at least IP30 and can only be accessed using a key or tool. Access to the rear enclosure must be limited to service personnel only.</p>
--	---

11 SOFTWARE INSTALLATION

Recommended Guidelines

11.1 Security

The configurator should be Installed on a service or commissioning engineers laptop, in a password protected user space.

It is advised that the SmartAlarm configurator provided with your order is stored in a safe location and that any configuration files are similarly secured. These include:-

The supplied configuration executable file “RTKSmartAlarmInstallerV*.*.exe”
A copy of the Configuration file Name.CSV (Downloaded from the Annunciator)
Annunciator activity log Name.txt

All of the above explained below:-

11.1.1 Configuration executable

This is the file provided with the unit that unpacks the configurator to a laptop or PC. This can also be downloaded from the MTL website at https://www.mtlinst.com/resources/datasheets/filter/new_smartalarm_annunciator

Please ensure that this file is kept in a secure location

11.1.2 Configuration file

This file is specific to each annunciator and contains all the settings pertaining to the setup. It is recommended that the latest file is dated and lodged in a safe location under lock and key. Any changes made to the unit must be reflected in a new .csv file.

11.1.3 Log file

The log file indicates every instance of the configurator being launched and any activity that trigger an action such as importing or exporting a .CSV configuration file, a sample of the file is shown below

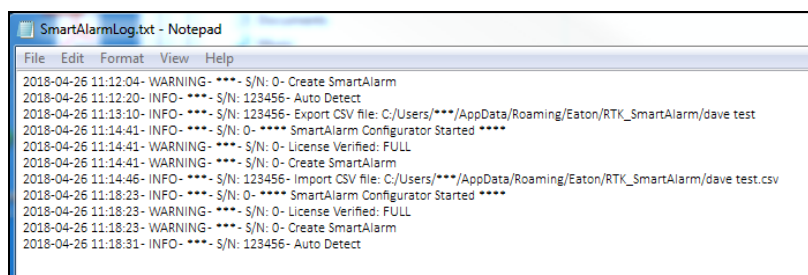

```
SmartAlarmLog.txt - Notepad
File Edit Format View Help
2018-04-26 11:12:04- WARNING- ***- S/N: 0- Create SmartAlarm
2018-04-26 11:12:20- INFO- ***- S/N: 123456- Auto Detect
2018-04-26 11:13:10- INFO- ***- S/N: 123456- Export CSV file: C:/Users/***/AppData/Roaming/Eaton/RTK_SmartAlarm/dave test
2018-04-26 11:14:41- INFO- ***- S/N: 0- **** SmartAlarm Configurator Started ****
2018-04-26 11:14:41- WARNING- ***- S/N: 0- License Verified: FULL
2018-04-26 11:14:41- WARNING- ***- S/N: 0- Create SmartAlarm
2018-04-26 11:14:46- INFO- ***- S/N: 123456- Import CSV file: C:/Users/***/AppData/Roaming/Eaton/RTK_SmartAlarm/dave test.csv
2018-04-26 11:18:23- INFO- ***- S/N: 0- **** SmartAlarm Configurator Started ****
2018-04-26 11:18:23- WARNING- ***- S/N: 0- License Verified: FULL
2018-04-26 11:18:23- WARNING- ***- S/N: 0- Create SmartAlarm
2018-04-26 11:18:31- INFO- ***- S/N: 123456- Auto Detect
```

11.2 Other security Considerations

- The SmartAlarm should be located in a secure environment with access only provided to authorised personnel
 - If within a public walk way, the unit should be mounted behind a locked viewing window
 - Unit firmware is not field upgradable and needs to be returned to base if required
 - The unit can be reset back to factory default to obviate any erroneous setting
- ### 11.4 Activity log

This log is located in the file path where the configurator is installed. This can be found by right clicking the SmartAlarm shortcut, selecting properties and clicking on the open File Location

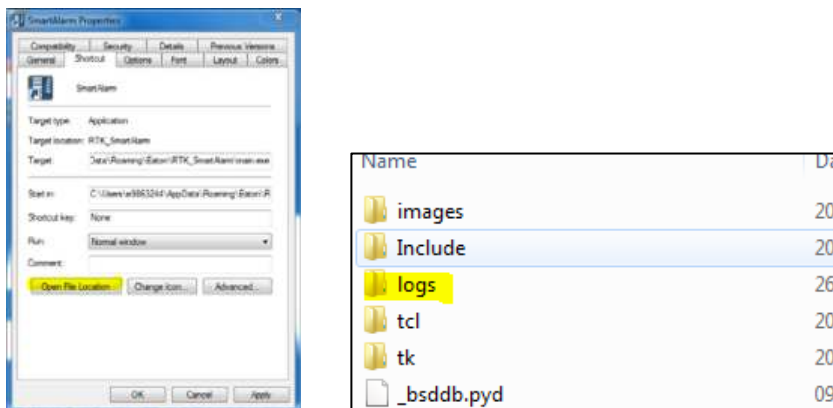

The log folder contains the log text file and if the unit has been scanned the scan document.

11.4.1 Log file

The log file indicates every instance of the configurator being launched and any activity that trigger an action such as importing or exporting a .CSV configuration file, a sample of the file is shown below

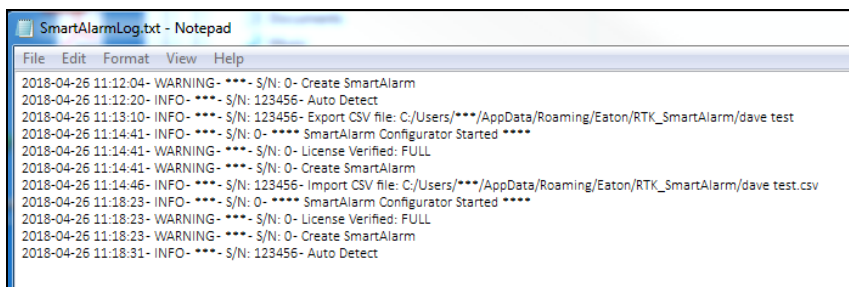

11.4.2 Scan File

This file is created when the scan function is used within the configurator. The scan data includes the type of card fitted into the unit and their firmware versions.

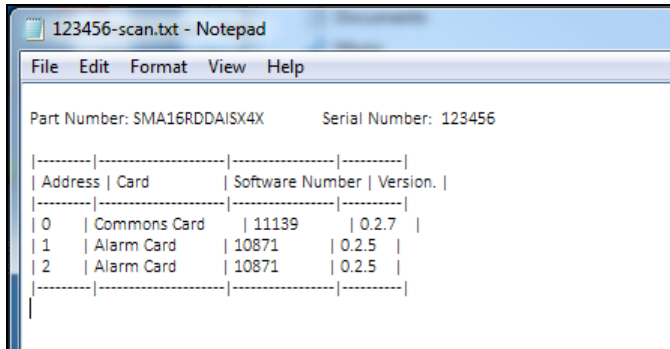

Configuration Software is provided free of charge on a conventional CD or the software can be downloaded from our Website:-

https://www.mtl-inst.com/resources/datasheets/filter/new_smartalarm_annunciator
in the section labelled SmartAlarm Software

To install the software Click on the RTKSmartAlarmInstallerV***
(*** = Version Number)

Software requirements are Windows 7 and above

Please select “Run” to start the install process.

- Select “Run” which will list the components to be installed

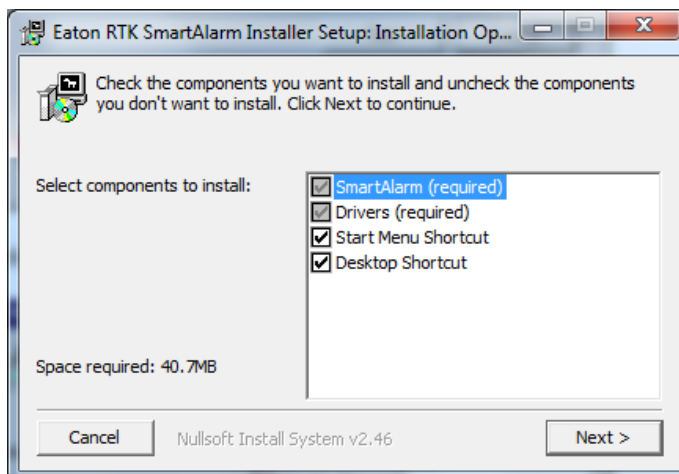

- Select “Next” which will show the default destination folder
- This followed by a license agreement. Click on “ I Agree” to proceed

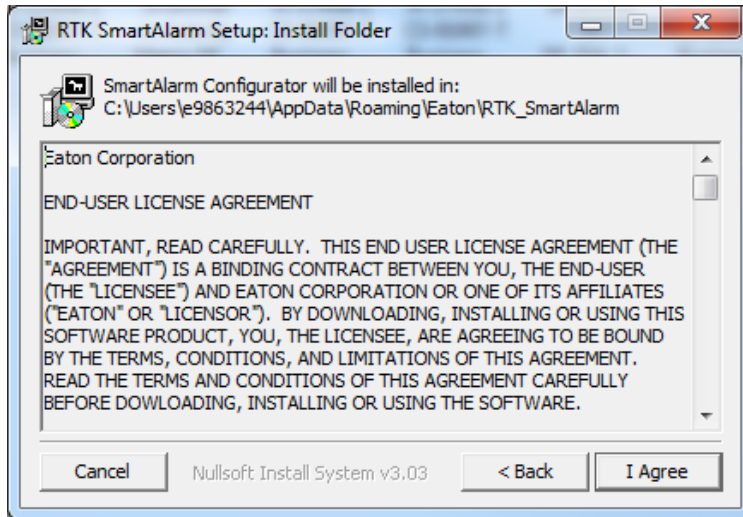

- Select “I Agree” to install the application and once complete select “Close”



- The desk top will show a quick launch icon – please select this Icon to open the application.
- Select the “File” menu which will prompt the user with the following options.

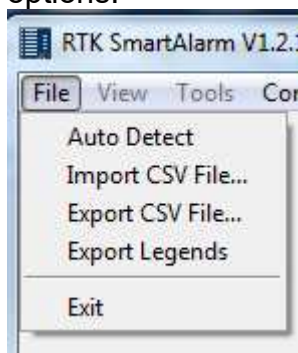

12 – AUTO DETECT HARDWARE.

To Auto Detect the settings within a SmartAlarm.

- Open the Eaton SmartAlarm configuration software using the “SmartAlarm” quick launch icon located on the desktop.
- Apply primary power to the SmartAlarm.
- Remove the rubber bung on the front of the SmartAlarm to access the USB programming port.
- Connect the Eaton supplied USB cable between the PC/Laptop and the SmartAlarm.
- When you initially plug-in the USB cable to the SmartAlarm you will notice a green LED near the USB port flash to indicate communication.
- From the “Comport” tool bar select the USB Com. port you will be using to communicate with the SmartAlarm. Note the Comport No varies depending on the devices connected to each PC and the USB port being used therefore more than one com port may be identified in the list.
- Use the “File” menu to select “Auto Detect” and note the green progress bar increases whilst installation is in progress and once complete an Auto Detect Complete message appears on the desk top - please select “OK”.
- Once Auto Detect is complete all of the settings shown will be an exact copy of those held in the associated SmartAlarm.

You are now ready to use the software as required.

Before any configuration changes take place Eaton, recommend a Master copy is saved to the PC/Laptop using the “File” menu – “Export CSV File” this ensures a master copy is available if you wish to revert back to the initial settings.

13 IMPORT CSV FILE

Open Configuration

Configurations are saved in CSV format and can be re-installed as required.

From the “File” menu select “Import CSV File” which will allow standard windows navigation to locate the saved configuration.

Once located select “Open” to install the previously saved configuration settings.

Please note this will overwrite all existing settings.

14 EXPORT CSV FILE

Save Configuration

Configurations are saved in CSV format and can be saved as required.

From the “File” menu select “Export CSV File” which will allow standard windows navigation to save the configuration.

Once saved the configuration can be viewed in Microsoft Excel format and edited as required.

After changes have been made the CSV file can be imported as described in the previous section.

Eaton recommend a copy of each SmartAlarm configuration is saved for future reference as required.

CAUTION

Do not editing the CSV file as this may stop the SmartAlarm working if edited incorrectly.

15 CREATE A NEW SYSTEM

Select “Create New SmartAlarm” is only used during manufacturing to select the order specific features required per SmartAlarm

This function is not used by customers

16 SYSTEM SETTINGS

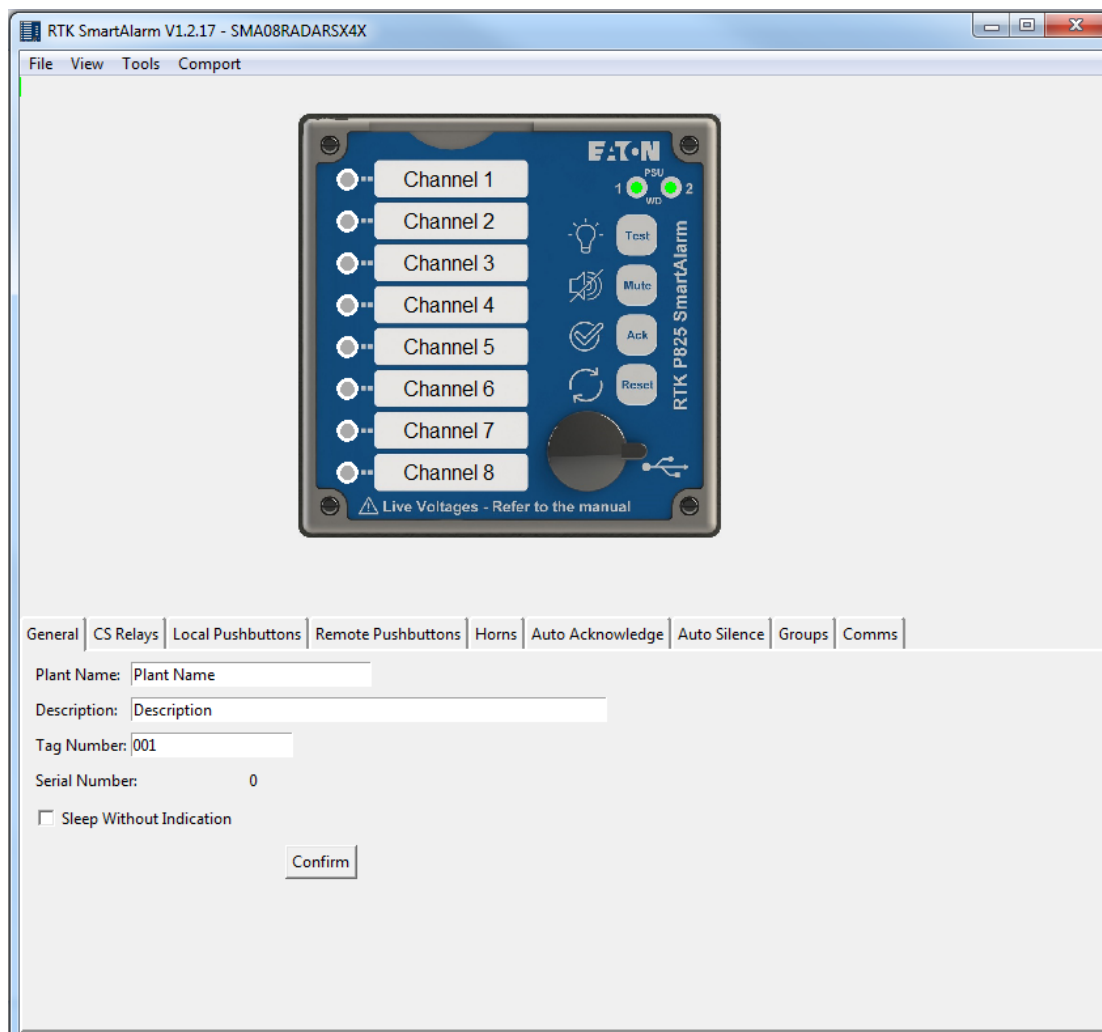

Auto Detect

The user is able to Auto Detect the configurations of an existing SmartAlarm once they have loaded the SmartAlarm configuration software onto a suitable PC and connected the USB Cable to the communication port located behind the rubber bung on the front of the SmartAlarm.

The auto detect facility is accessed via the “File” menu as shown above.

Once selected all of the settings stored within the SmartAlarm are read into the software allowing the user to view, save or modify the configuration as required.

View

The following settings are available under the “View” menu.

Advanced

As standard the configuration software restricts some of the features to simplify selection of features. In more complex applications additional menus are available for example. Increased number of groups or custom sequences and these are accessed via the “View Advanced” menu.

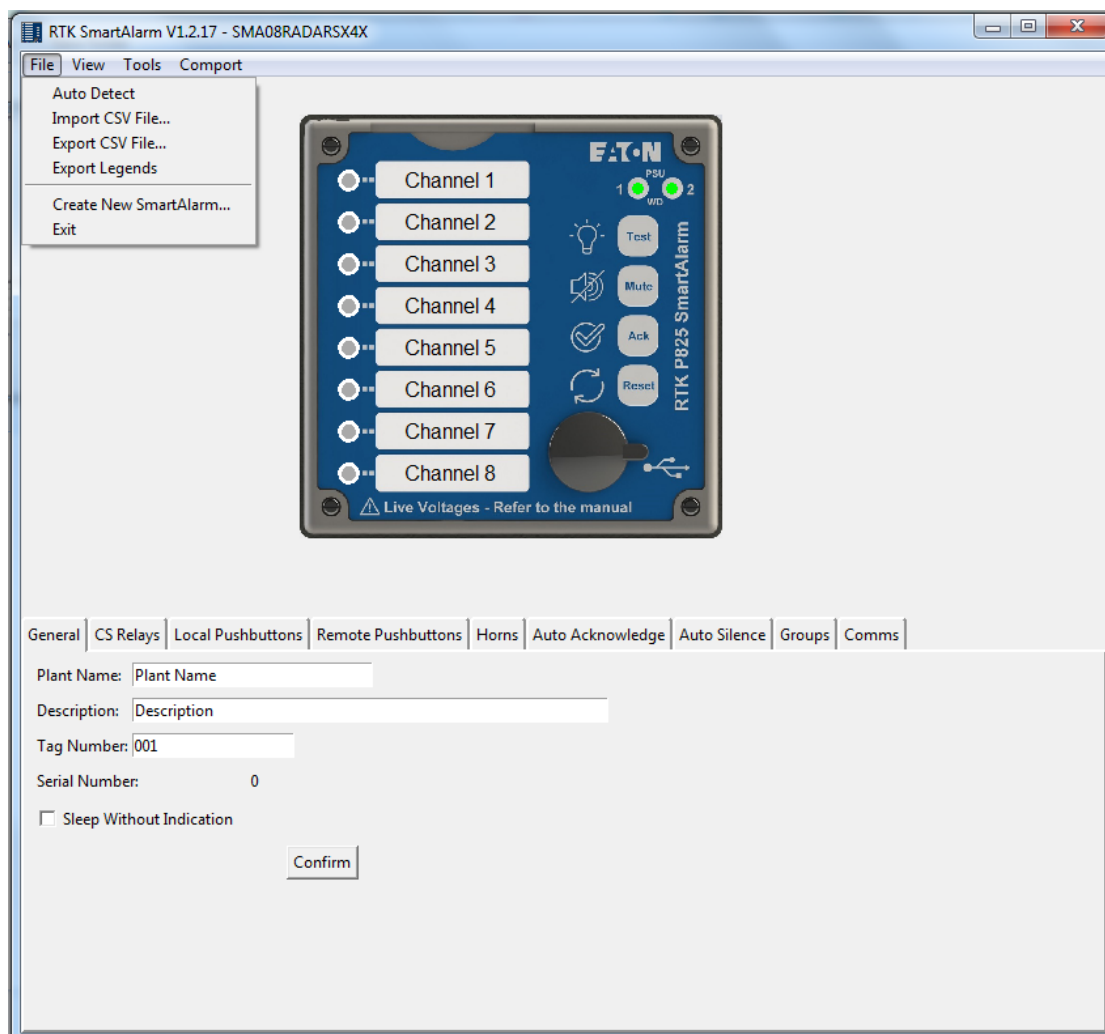

Front View of Annunciator

Selecting the “View” menu – “Front” menu provides a graphic of the alarm fascia to aid programming.

Tools

The following settings are available under the “Tools” menu

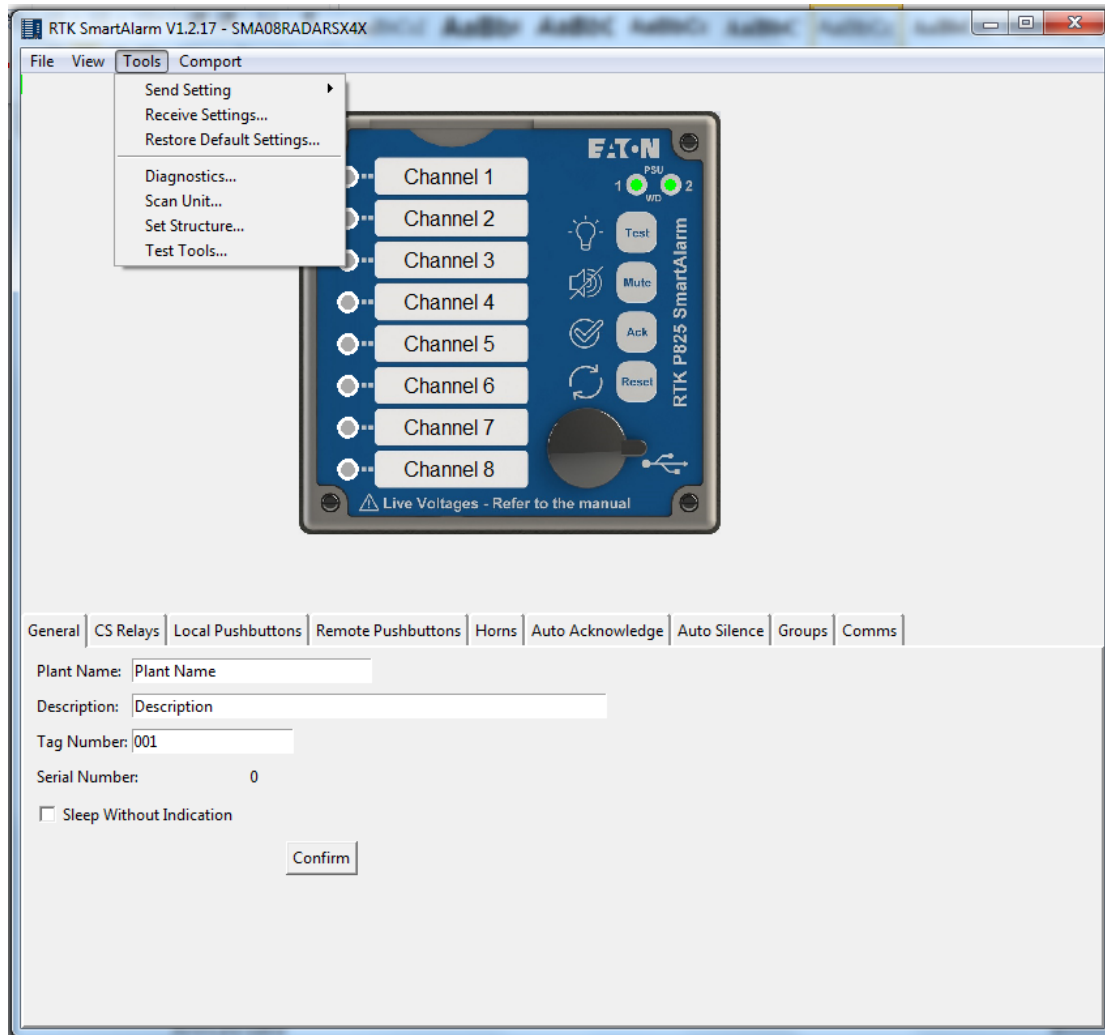

Send Settings

Once the SmartAlarm has been connected to a suitable PC/Laptop via the Eaton supplied USB Cable the user is able to download any configuration changes to the unit as required. Eaton recommend that before downloading the customer uploads the original settings and saves them on the PC/Laptop for future reference or as a backup.

Receive Settings

Once the SmartAlarm has been connected to a suitable PC/Laptop via the Eaton supplied USB Cable the user is able to upload the configuration settings from the unit as required. Before any changes are made Eaton recommend that a copy of the original settings are saved for future reference or as a backup.

Restore Default Settings

If required the user is able to return the unit to the factory default settings, however please note this will revert ALL settings within the Annunciator so should only performed with caution.

Diagnostics

Once the SmartAlarm has been connected to a suitable PC/Laptop via the Eaton supplied USB Cable the user is able to select Diagnostics to check the dynamic status of the SmartAlarm.

Set Structure

Please consult factory before modifying the structure of a supplied Annunciator.

Scan Unit

This allows the user to identify the address, card type, software version and software revision number for the cards within the SmartAlarm. This will aid fault finding or spare parts identification.

Test Tools

Production use only.

General Tab

The fields listed under the “General” tab allow the user to uniquely identify each Alarm Annunciator System to aid with the storage and retrieval of configuration data.

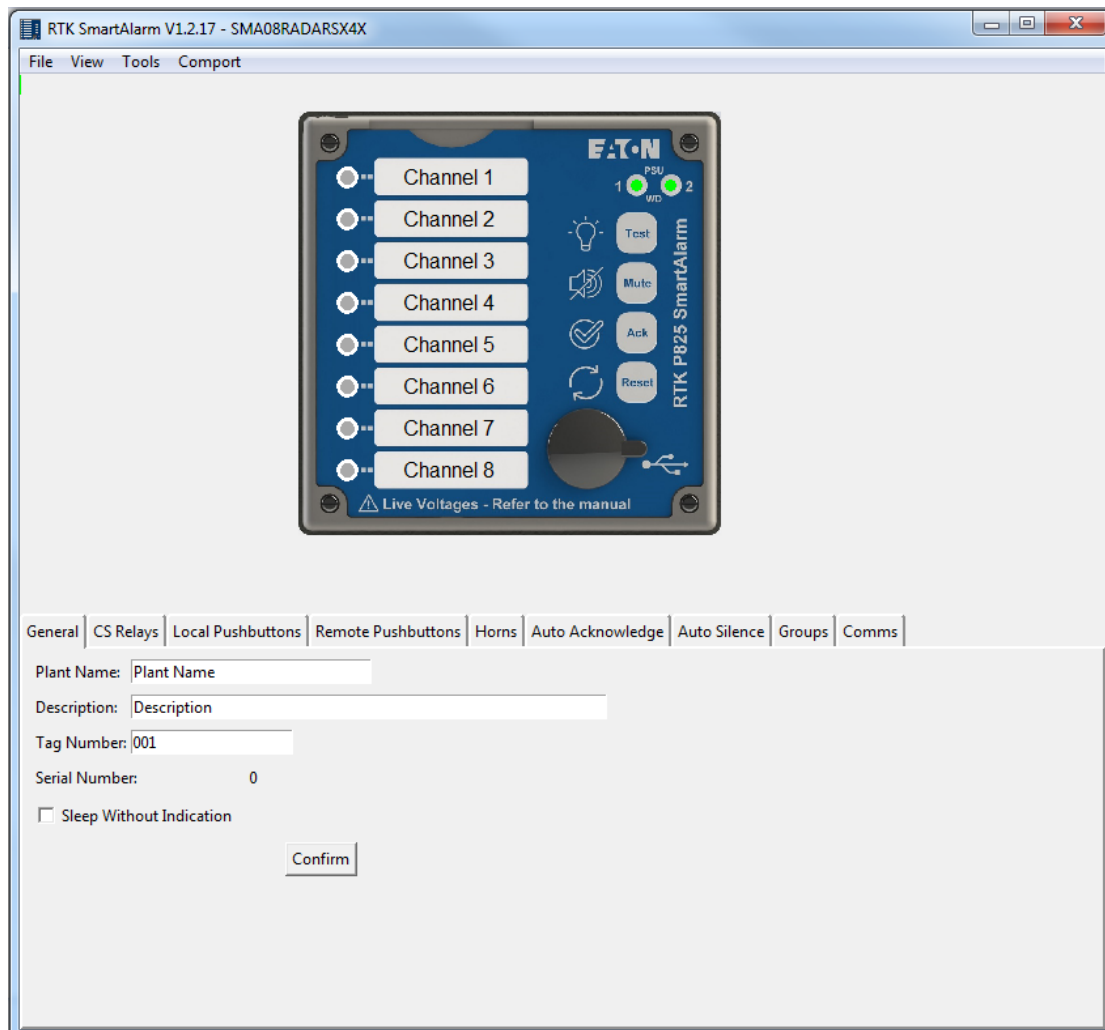

The user can update any of the fields within the software but the changes will only be saved after the “**Confirm Settings**” control button is pressed using a left mouse click. Any changes will need to be sent to the annunciator via the Tools menu “Send Settings”.

Plant Name

Allows the user to allocate a unique name to define the location of the device.

Description

This field is used to identify the specific plant area or annunciator function within the plant.

Tag No.

This field allows a Customer assigned number to be used to identify a unique alarm annunciator.

Serial No.

A serial number is automatically provided once the software is communicating with the alarm annunciator.

Address Offset

This allows the user to offset the Node address to match the application.

Sleep Without Indication

Selecting this feature inhibits the heart-beat pulse which cyclically pulses the alarm LED's whilst the unit is in Sleep Mode (Full details of Sleep Mode are provided within this manual).

CS Relays (Common Service Relays)

Each channel within the annunciator can be assigned to a single or multiple groups. The group can be software linked to any of the common relays to provide contact outputs for use with 3rd Party devices.

The fields listed under the “CS Relays” tab allow the user to configure the common system relays to follow groups as required.

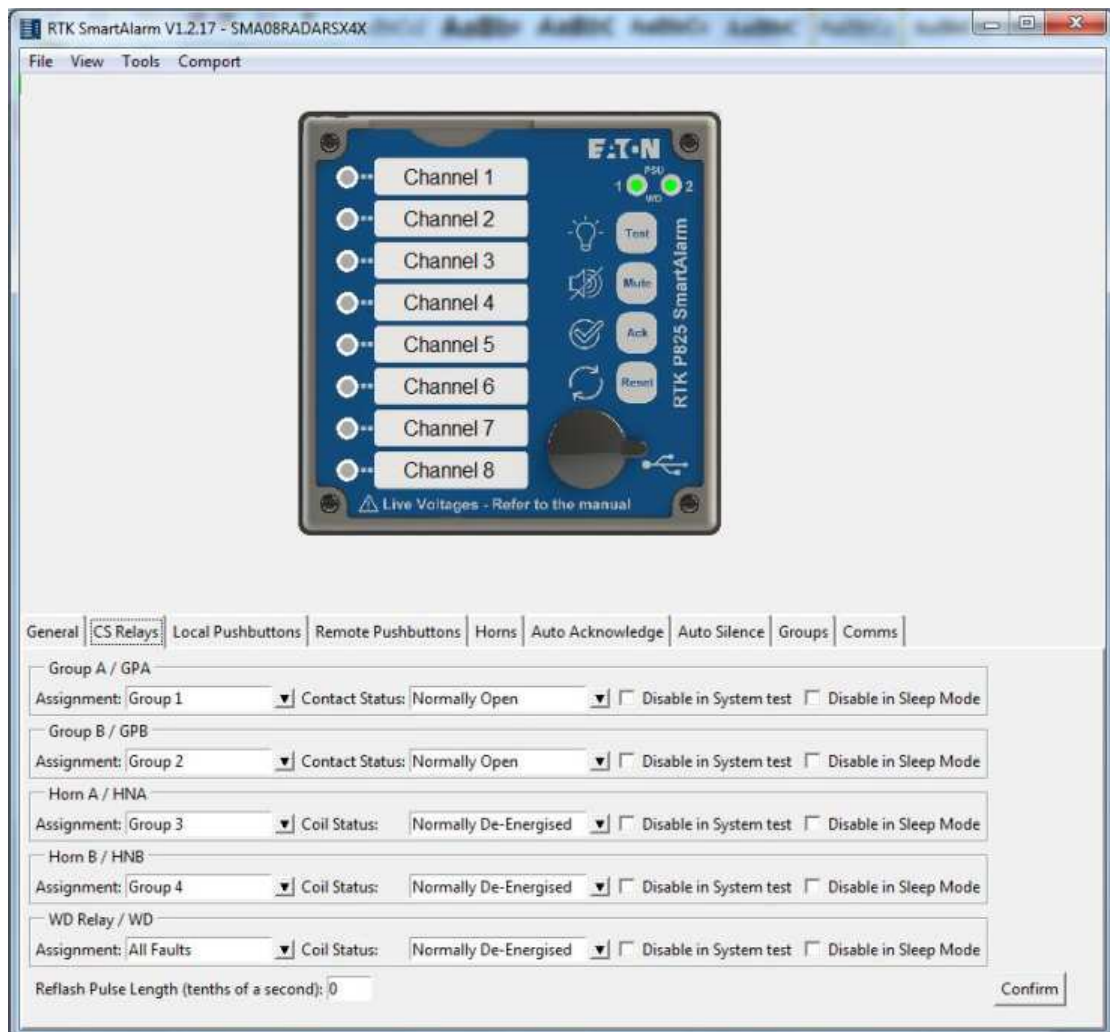

Horn A - HNA

The default setting for this relay is Horn A / HNA, the relay is normally de-energised and provides a N/O contact for use with external audibles / 3rd party devices. The relay will activate on alarm and will return to normal after Mute or Acknowledge have been pressed. The relay must be assigned to a group and the group type needs to be set as “Audible” for the relay to operate correctly.

- The coil state can be set to Normally Energised or Normally De-Energised, by selecting the required feature using the Drop-down menu shown next to the coil status field.

Horn B - HNB

The default setting for this relay is Horn B / HNB, the relay is normally de-energised and provides a N/O contact for use with external audibles / 3rd party devices. The relay will activate on alarm and will return to normal after Mute or Acknowledge have been pressed. The relay must be assigned to a group and the group type needs to be set as “Audible” for the relay to operate correctly.

- The coil state can be set to Normally Energised or Normally De-Energised, by selecting the required feature using the Drop-down menu shown next to the coil status field.

Group A - GPA

The default setting for this relay is Group A / GPA, the relay is normally de-energised and provides a configurable contact for use with 3rd party devices. The relay will activate on alarm and will return to normal after the process has returned to normal and the alarm has been cleared. The relay must be assigned to a group and the group type needs to be set as “Alarm” for the relay to operate correctly.

- A latching Relay is used for the Group Relay function allowing the contact state can be set to Normally Open or Normally Closed by selecting the required feature using the Drop-down menu shown next to the coil status field.

Group B - GPB

The default setting for this relay is Group B / GPB, the relay is normally de-energised and provides a configurable contact for use with 3rd party devices. The relay will activate on alarm and will return to normal after the process has returned to normal and the alarm has been cleared. The relay must be assigned to a group and the group type needs to be set as “Alarm” for the relay to operate correctly.

- A latching relay is used for the Group Relay function allowing the contact state can be set to Normally Open or Normally Closed by selecting the required feature using the Drop-down menu shown next to the coil status field.

Optional Settings

The following options apply to any of the common relays.

Assigning Relays to Groups

Any relay can be set to follow any group within the annunciator using the drop down menu.

Reflash Function

When using the GPA or GPB common alarm relays a reflash function can be used to indicate that multiple alarms are occurring within the group. When an alarm within the group activates the relay will change state and each time a new alarm occurs within the same group the relay will revert to normal and reactivate, (Reflash). The drop-down menu which allows selection of the group includes selection of the group and reflash as an option.

Disable in System Test

A relay can be prevented from operating during System Test by selecting the “Disable in System Test” check box shown on the previous page. For example you may not need the audible to sound during system test, this feature allows the user to disable the relay during the test cycle.

Disable in Sleep Mode

Sleep mode is an optional setting which allows the user to disable the visual, audible and common relays during unmanned periods.

A relay can be prevented from operating whilst the annunciator is in sleep mode by selecting the “Disable in Sleep Mode” check box shown above. For example you may wish to disable the horn relays but allow the common alarm relays to continue to operate as normal during unmanned periods.

Reflash Pulse Length

As indicated above the group relays can have a reflash feature enabled which interrupts the output each time a new alarm occurs within the group. The reflash pulse length can be set in tenths of a second to suit individual applications.

Alternative Functions for any Relay

The drop-down menu provided next to the “Assignment Field” of each relay allows the user to set any of the Relays to:-

- Any group (Group-1 to Group-30).
- Any group with Reflash enabled (Group-1 to Group-30).
- Pushbutton Follower where the relay will faithfully follow the operation of any one of the following Pushbutton functions:- Lamp Test, Mute, Ack, Reset, 1st Reset or System Test.
- All faults Relay where the relay activates if any fault is detected within the Annunciator.
- Field Contact fault where the relay activates when the signal supply is lost which can be used to flag 3rd Party devices.

Local Pushbuttons

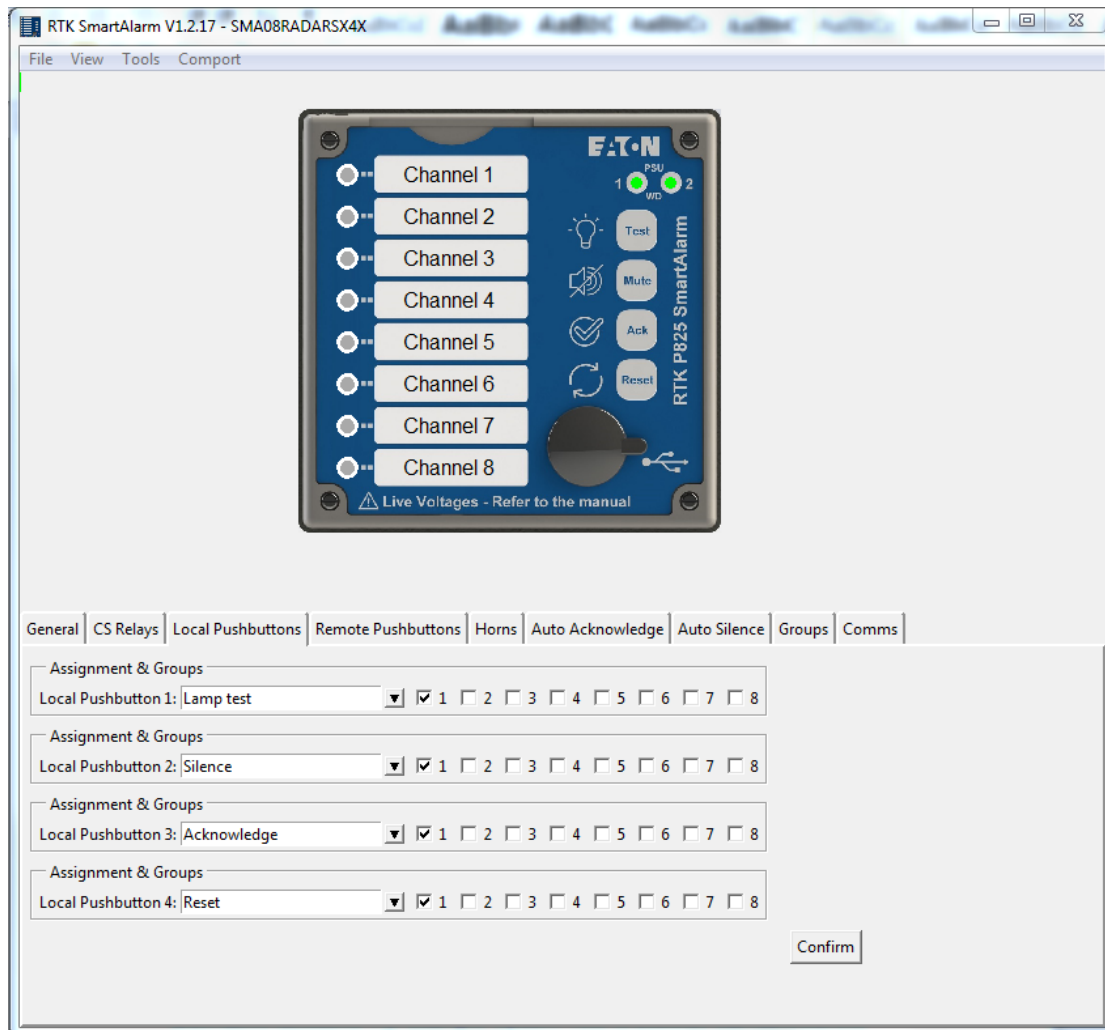

Each SmartAlarm is equipped with four integral tactile pushbuttons used to control the operational sequence of the annunciator. The local pushbuttons tab allows the user to change the function of a pushbutton if required.

A drop-down menu provided per pushbutton allows the user to select alternative functions. For example System Test is used as standard but the user may prefer Lamp Test as an option.

Once the alternative function has been selected the user will need to press “Confirm” and the changes will need to be downloaded to the annunciator via the tools menu.

Any internal pushbutton can be assigned to a pushbutton group and any channel can be set to match the associated group.

For example:- Channel-1 to 4 can be set to Pushbutton Group-1 and the internal pushbuttons can be set to control Pushbutton Group-1. Only alarms within the group would be controlled by the internal pushbuttons.

The remaining alarms can be assigned to Pushbutton Group-2 and these can be controlled by external pushbuttons if required.

Remote Pushbuttons

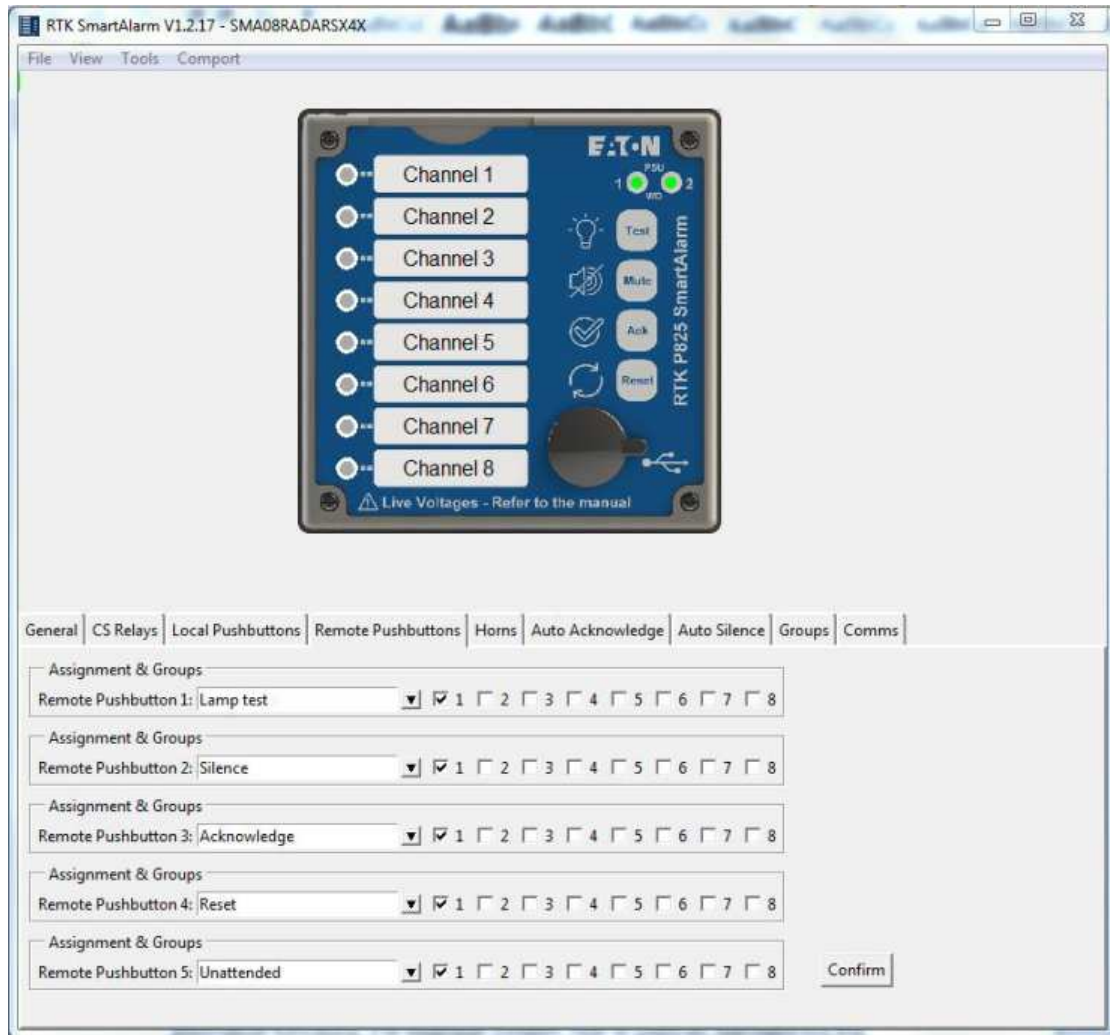

Each SmartAlarm is equipped with five optically coupled digital inputs which can be used with normally open momentary pushbuttons to control the operational sequence of the annunciator. The remote pushbuttons tab allows the user to change the function of a pushbutton if required.

A drop-down menu provided per pushbutton allows the user to select alternative functions. For example System Test is used as standard but the user may prefer Lamp Test as an option.

Once the alternative function has been selected the user will need to select “Confirm” and the changes will need to be downloaded to the annunciator via the tools menu – “send settings”.

Any external pushbutton can be assigned to a pushbutton group and any channel can be set to match the associated group.

For example:- Channel-1 to 4 can be set to Pushbutton Group-1 and the internal pushbuttons can be set to control Pushbutton Group-1. Only alarms within the group would be controlled by the internal pushbuttons.

The remaining alarms can be assigned to Pushbutton Group-2 and these can be controlled by external pushbuttons if required.

Inhibit Function

As an alternative any of the five pushbutton inputs can be set for use with an external inhibit switch. The inhibit switch should be connected between +VB and the associated pushbutton input. When the switch is in the closed position all alarms within the inhibit group will be prevented from operating until the inhibit switch is returned to normal

It is possible to assign any channel with the Annunciator to be included in inhibit group-1 to inhibit group-8 as required

To link a channel to an inhibit group first select the associated LED within the software faceplate to access the “channel”-tab.

Under the “Manual Inhibit” field assign the channel to an inhibit group as required and select “Confirm” followed by “Tools” – “Send Settings” to download the settings to the Annunciator.

Assigning Channel to Inhibit Groups

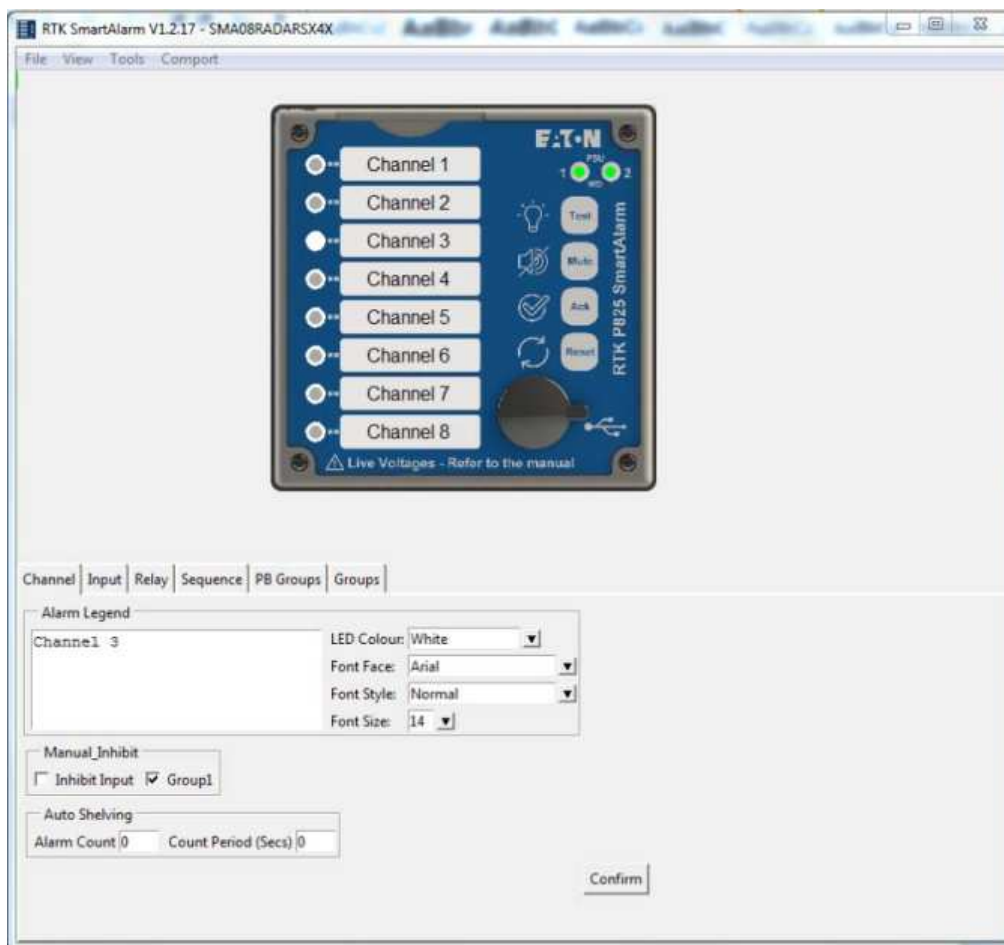

In the above example channel 3 has been set to Inhibit Group 1

Assigning a Remote Pushbutton Input to Inhibit

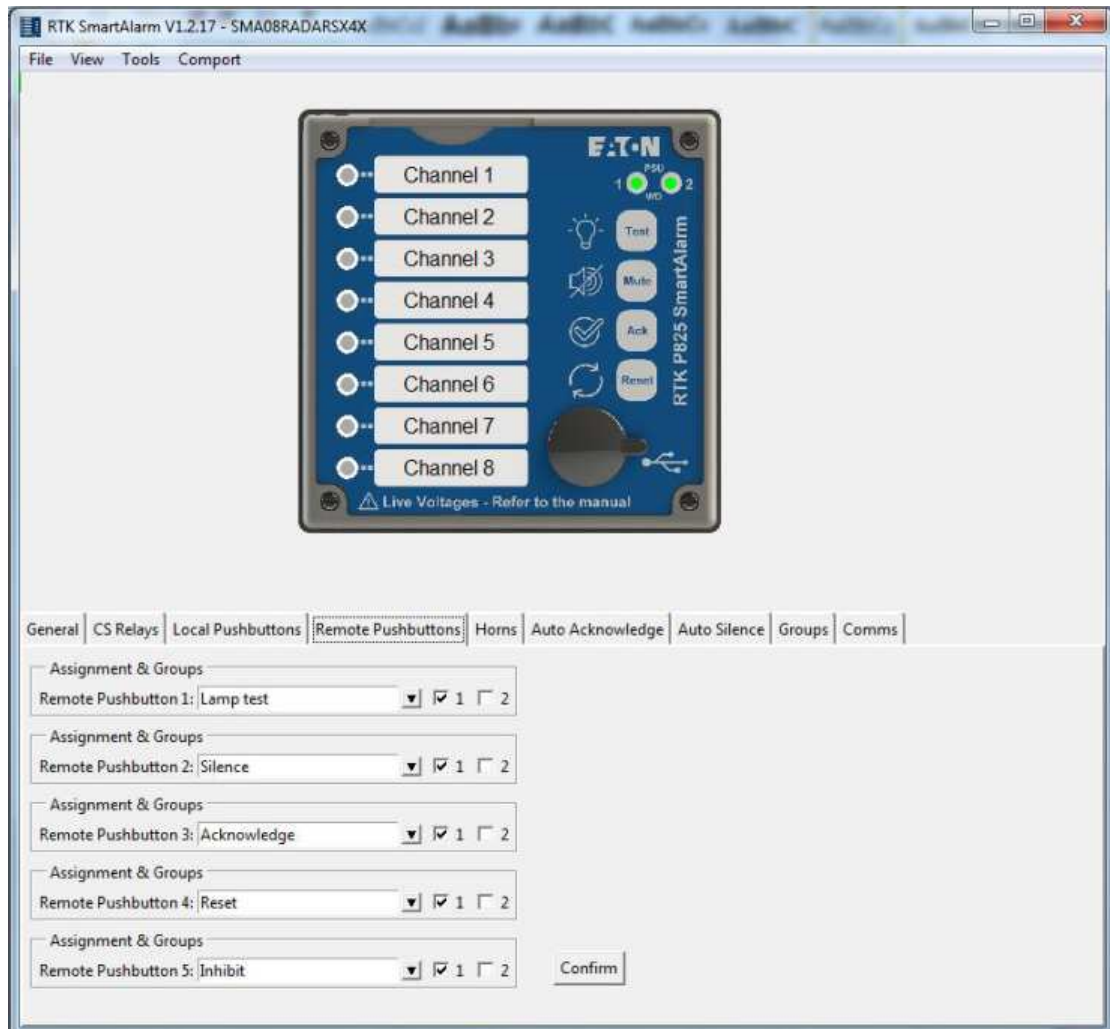

In the above example Remote Pushbutton 5 has been set as the Input for Group2 Inhibit Switch

Sleep Mode

As an alternative any of the five pushbutton inputs can be set for use with an external inhibit switch used to place the Annunciator into Sleep Mode during unmanned periods. The sleep mode switch should be connected between PCom and the associated pushbutton input.

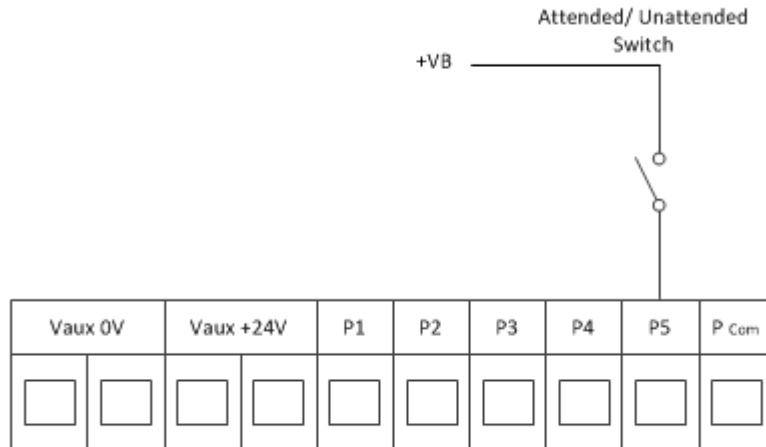

PB5 for remote pushbutton-5 Used as a Sleep Mode Input.

CAUTION

The common return for the external pushbuttons is terminal PCom and this terminal will provide the same voltage level as the internally generated signal contact supply

CAUTION

On standard systems +24VDC is used, however 125VDC may be present if HV signal inputs were specified at the time of order. In this event

Assigning a Remote Pushbutton Input to Sleep Mode

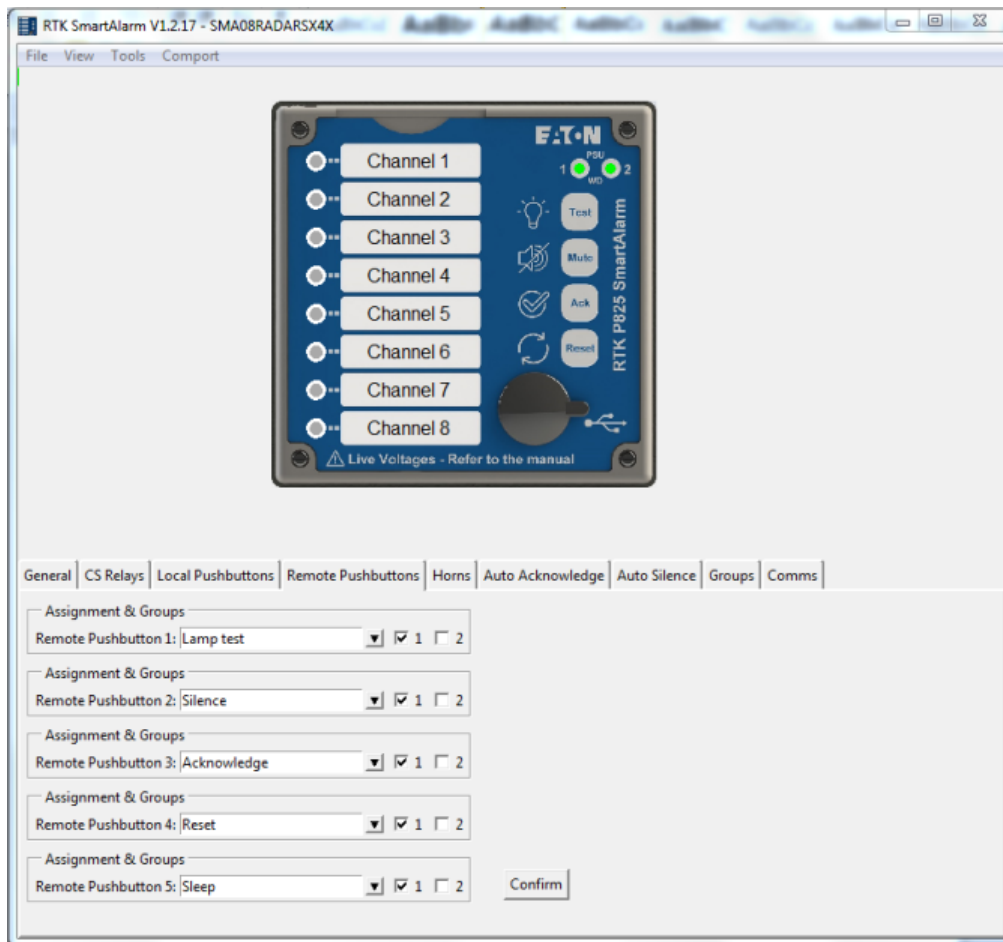

Whilst in sleep mode the audible alarms are disabled and the individual channel LED's are disabled to save power and prevent noise pollution during unmanned periods.

When the switch is maintained in the closed position the Annunciator will remain in sleep mode until the switch is returned to normal.

Please note:-

- The individual channel repeat relays will continue to operate as usual during sleep mode to allow notification of alarms to 3rd Party devices
- The two group relays GPA, GPB & the Watchdog relay can be prevented from operating in sleep mode under the Common Services Relays – Tab if required.

In the above example Remote Pushbutton 5 has been set as an input for the external “Attended / Unattended” sleep mode switch.

Common Relay Operating In Sleep Mode

Each of the common relays can be prevented from operating in “Sleep” mode if required.

For example during unmanned periods the two horn relays can be prevented from operating to prevent noise pollution whilst the 2 Group and 1 Watchdog relay can continue to operate as normal.

Inhibiting Common Relays During Sleep Mode

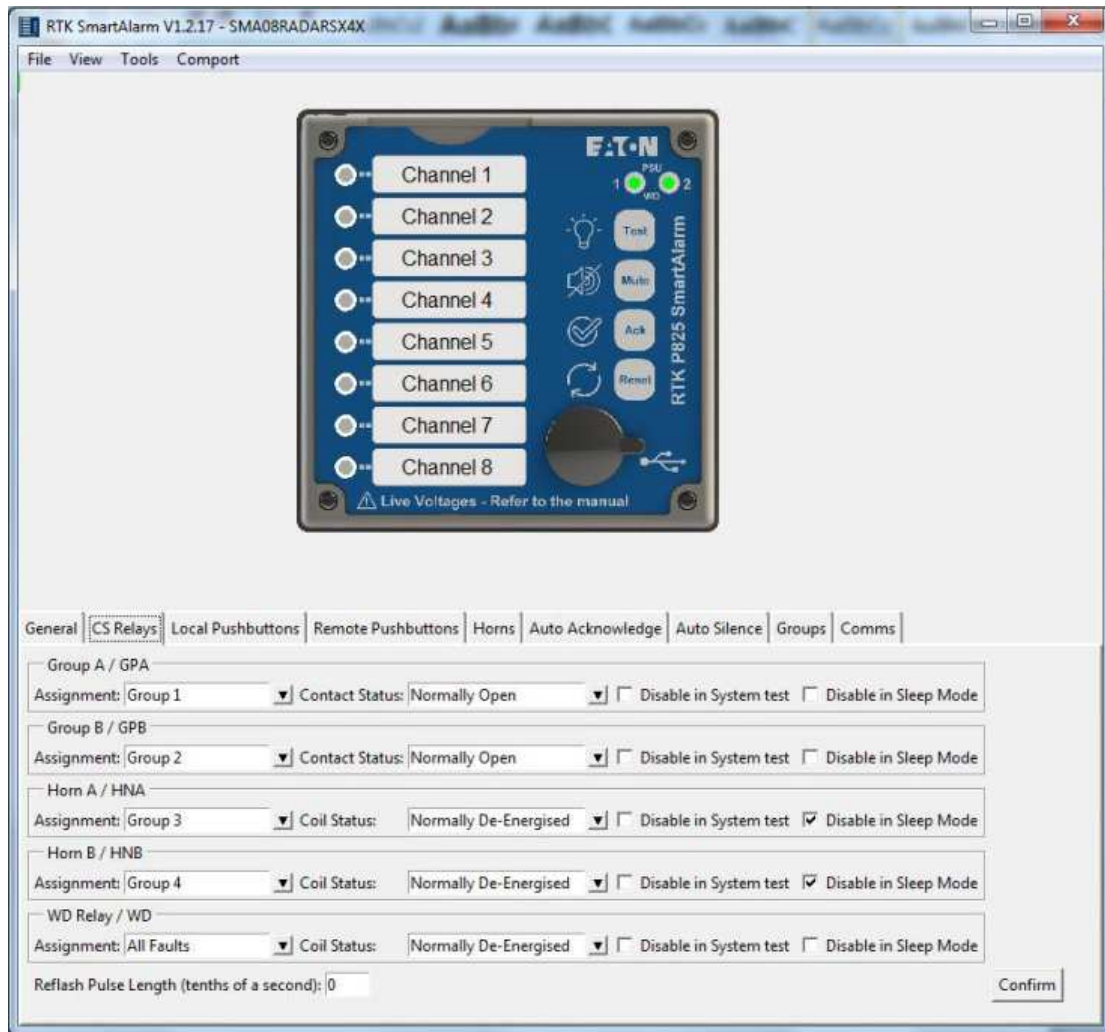

In the above example HNA and HNB horn relays will not operate during sleep mode.

Sleep Mode Heartbeat

To indicate that the annunciator is in sleep mode the associated alarm LED's pulse periodically (heart beat pulse).

In some applications this pulse may not be required and it can be disabled by selecting "Sleep Without Indication" under the "General" tab as shown in the below screenshot. Once the setting has been made select "Confirm" – "Tools" menu – "Send Settings" to download the changes to the SmartAlarm.

Disabling Sleep Mode Heartbeat

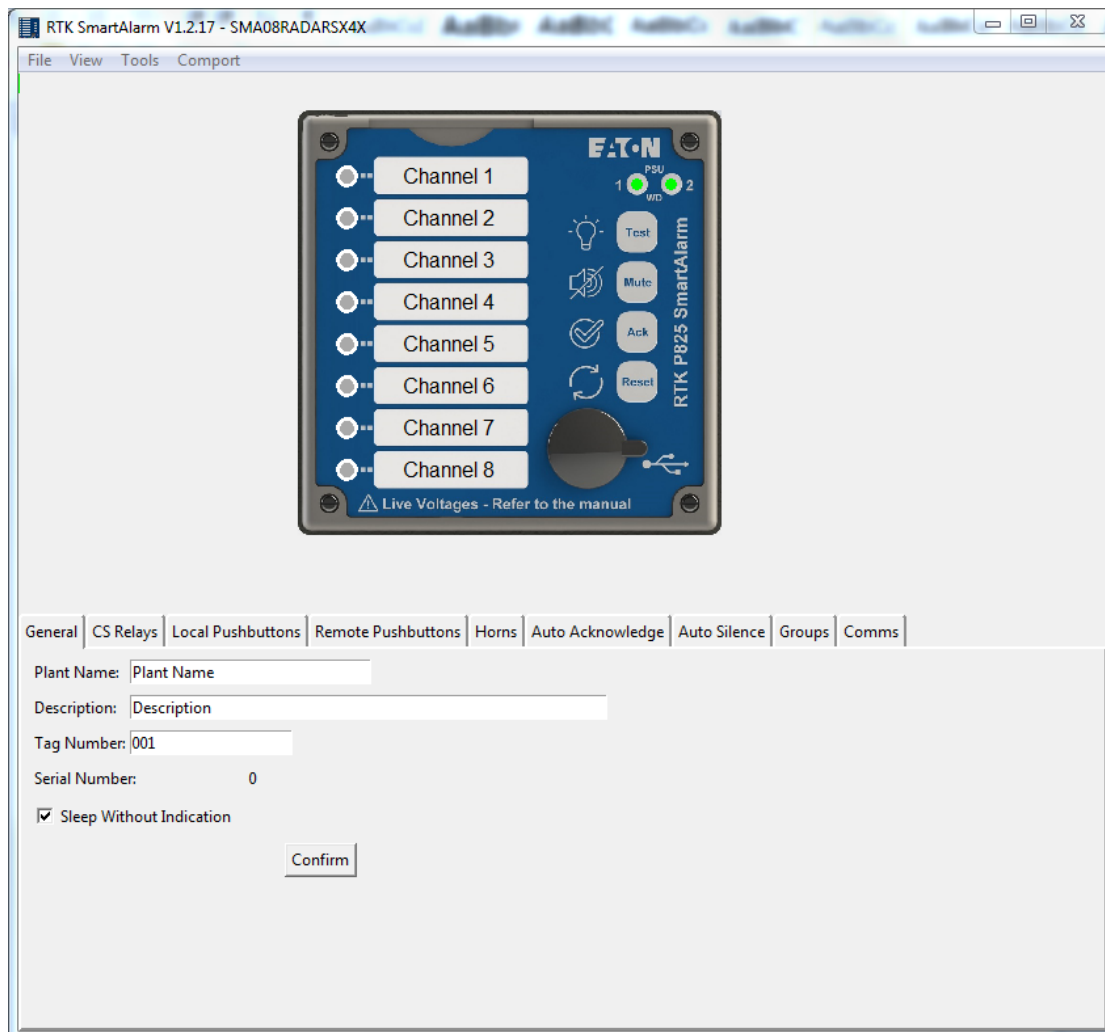

Horn

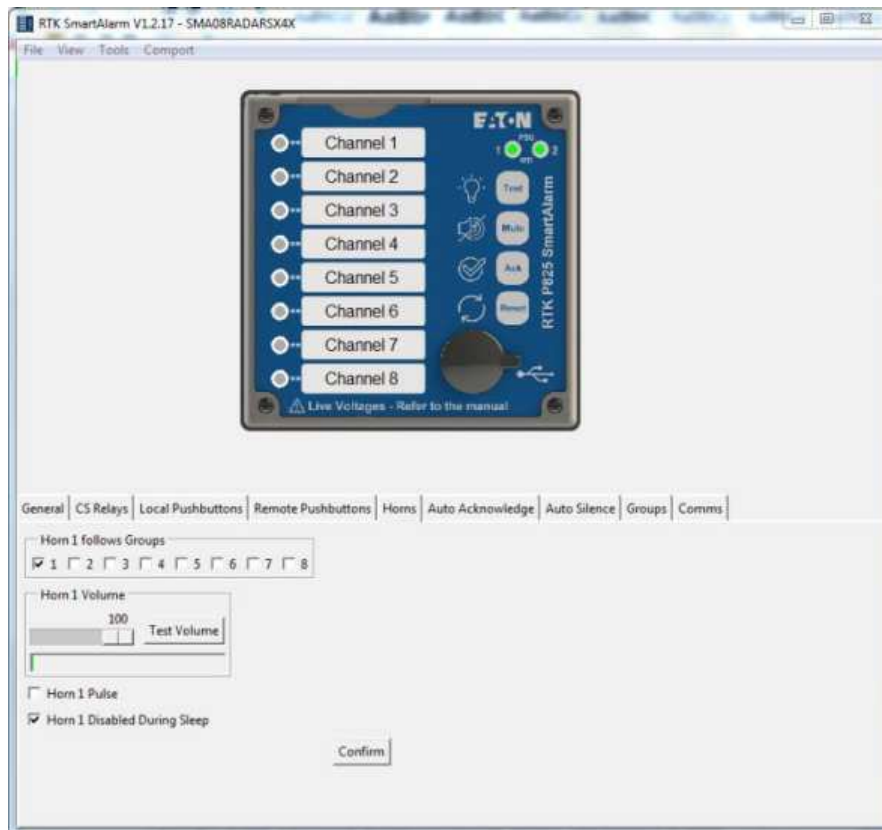

As standard the user can assign any channel to any group within the annunciator.

A maximum of 32 groups are available however to simplify configuration in the normal view only 8 groups are shown.

The remaining groups can be accessed if the user selects “View” followed by “Advanced”.

Once the alarms have been assigned to groups and the group type has been set to “Audible” the group or groups can be linked to the internal audible as required.

For example

- If channels 1 to 8 have been set to Group-1
- The Group type has been set to “Audible”
- The internal horn-1 can be linked to the group by selecting Group-1 under the horns tab

Screen shot shown above for reference.

Auto Acknowledge

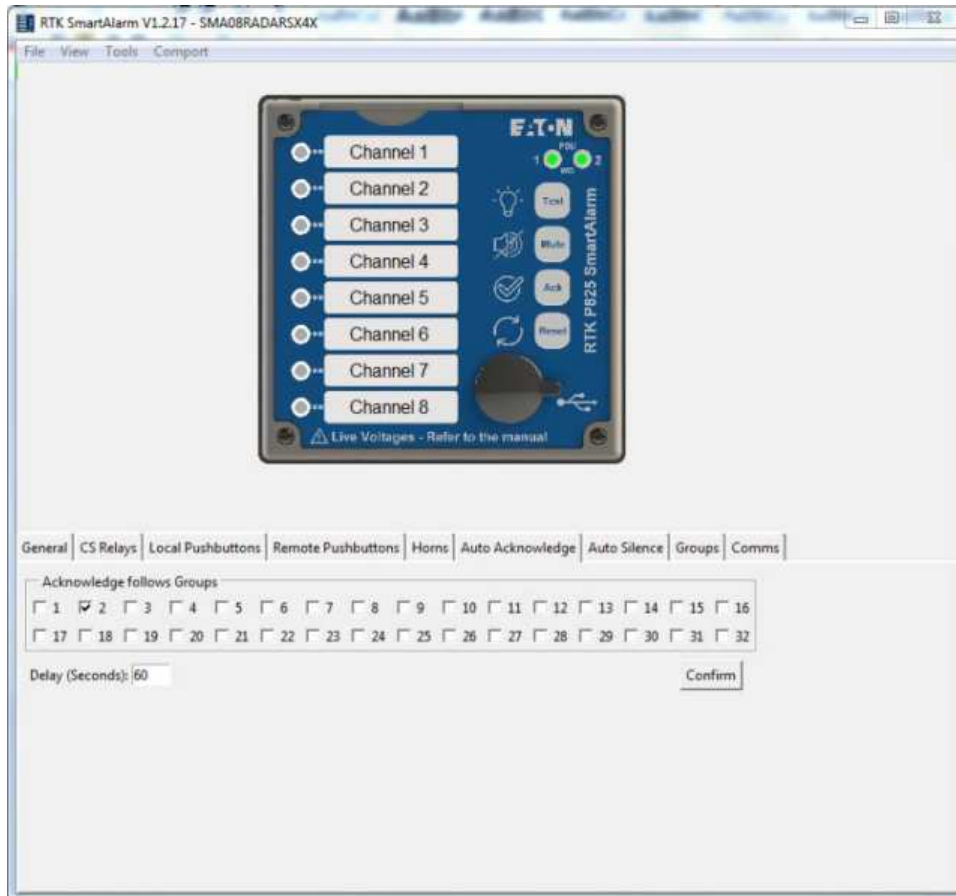

In applications where the annunciator is left unattended for long periods noise pollution can be prevented using the automatic acknowledge feature.

This feature is used to assign the automatic acknowledge function to the associated group.

In the normal view 8 groups are shown as standard and the remaining groups can be accessed if the user selects “View” followed by “Advanced”

The “delay” field allows the user to enter a time delay in seconds and once set the annunciator will automatically acknowledge the alarms after the pre-set period has elapsed.

The automatic acknowledge feature will silence the audible and the visual alarm will also be acknowledged in accordance with the selected ISA sequence.

Please note as the timer is triggered from the horn circuit the user must select automatic acknowledge OR automatic silence as either function will stop the timer.

Auto Silence

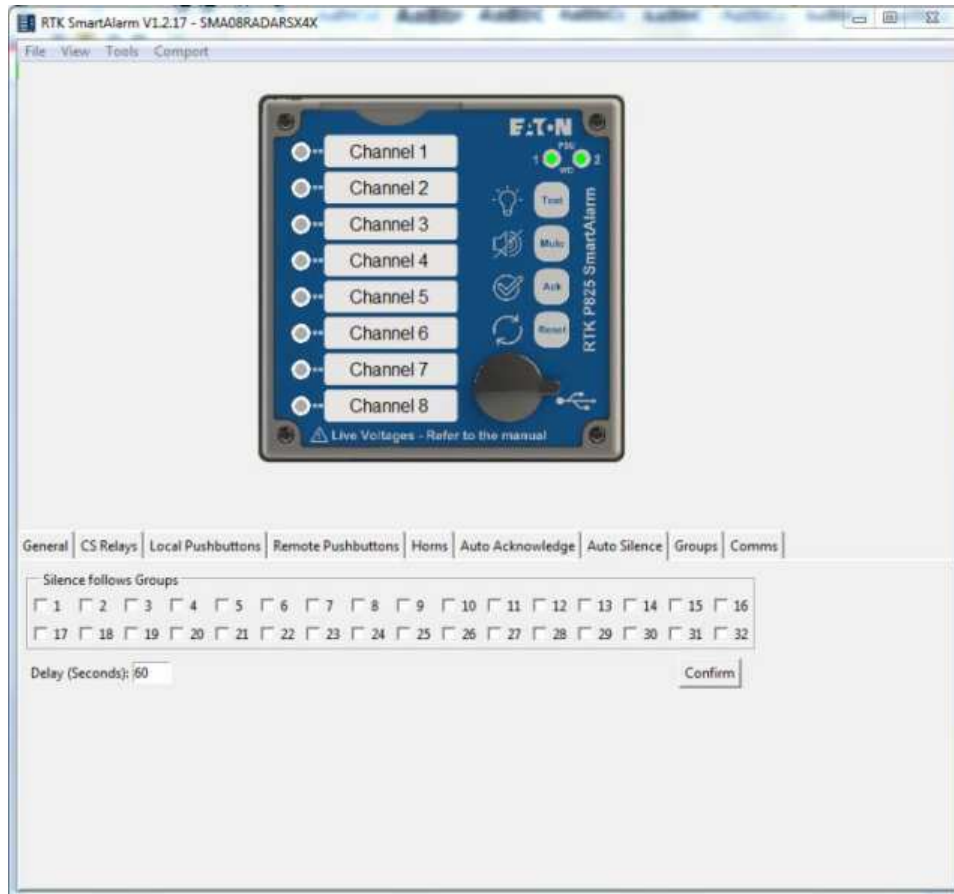

In applications where the annunciator is left unattended for long periods noise pollution can be prevented using the automatic silence feature.

This feature is selected under the auto silence tab where the user can assign the automatic silence function to the associated group.

In the normal view 8 groups are shown as standard and the remaining groups can be accessed if the user selects "View" followed by "Advanced"

The "delay" field allows the user to enter a time delay in seconds and once set the annunciator will automatically silence the audible after the pre-set period has elapsed.

Please note

1. This feature only silences the audible alarm the visual alarm will continue to operate in accordance with the selected ISA sequence.
2. The timer is triggered from the horn circuit therefore the user must select automatic acknowledge OR automatic silence as either function will stop the timer.

Groups

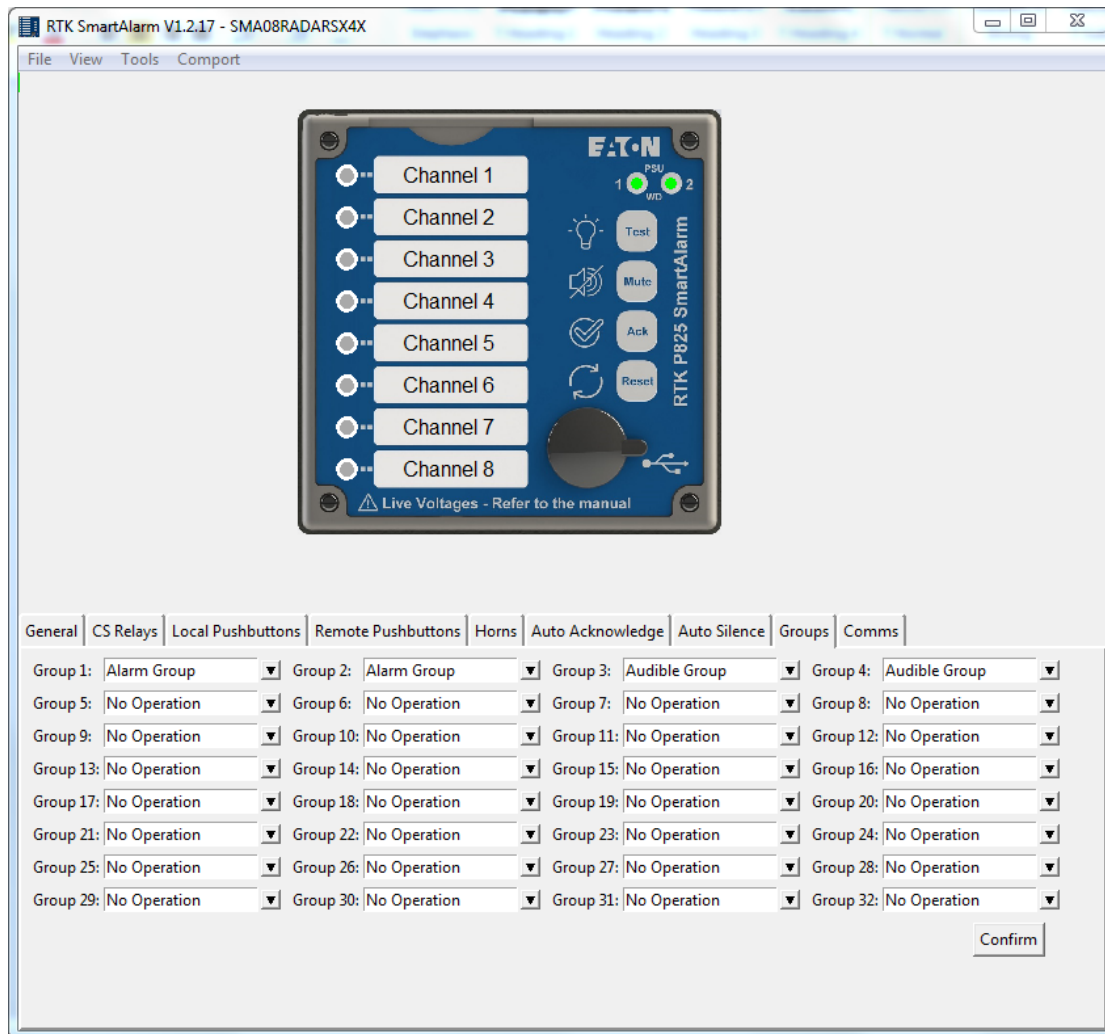

Any channel within the Annunciator can be set to be part of Group-1 to Group-32 as required.

Group Types

First-Up Group

In applications where the annunciator is monitoring alarms which are interlinked for example: Compressor and Turbine monitoring it is important to identify the first alarm to occur within the group as it simplifies and quickly identifies the root cause of failure.

Once the alarms have been assigned to a group the “Groups” function needs to be identified using the drop-down menu provided against each group.

For example if channel 1 to 8 have been assigned to Group-8 and they are all part of the same first-up group the drop-down menu for Group-8 should be set to “First-Up Group”

Input Group

Input Groups are typically used with Common Relays GPA and / or GPB and 3rd party devices to identify that an alarm / alarms with a group are in the abnormal condition.

With “Input Groups” the common relay would activate when an alarm in the group occurs and the common relay would automatically return to normal when the Input returns to normal.

Please note if multiple channels are used with the Group - ALL of the alarms must be in the non-alarm state before the common relay returns to normal.

Any channel within the Annunciator can be assigned to any group and once assigned the “Groups” function needs to be set to “Input Group” using the drop-down menu provided against each group as required.

Once set the Common Relay / Relays need to match to follow the Group as required.

Audible Group

Any channel within the Annunciator can be assigned to any group and once assigned the “Groups” function needs to be set using the drop-down menu provided against each group

For example if channel 1 to 8 have been assigned to “Group-1” and they are all part of the same audible group the drop-down menu for Group-1 should be set to “Audible Group”

Once selected the Internal Audible or Common Relays should be set to follow the associated horn group as required.

Ring back Audible Group

When using ISA R – Ring Back Sequence the associated LED slow flashes to indicate to the operator that an alarm has returned to normal.

In addition to the visual prompt the annunciator can sound an audible to prompt the operator that Reset can be pressed to clear the alarm.

Alarms set to alarm sequence ISA R (Ring Back) and a Group for example Group-7 can be set to a RB (Ring Back) Audible Group using the drop down menu provided against Group 7.

Group 7 can be typically assigned to HNB Horn Relay B and an external horn differing in tone from the integral audible can be used to identify that an alarm has returned to normal.

Grouping Example

The following steps identify how to set the Group, Group Type and assign the Group to Internal Horn and Common Relays.

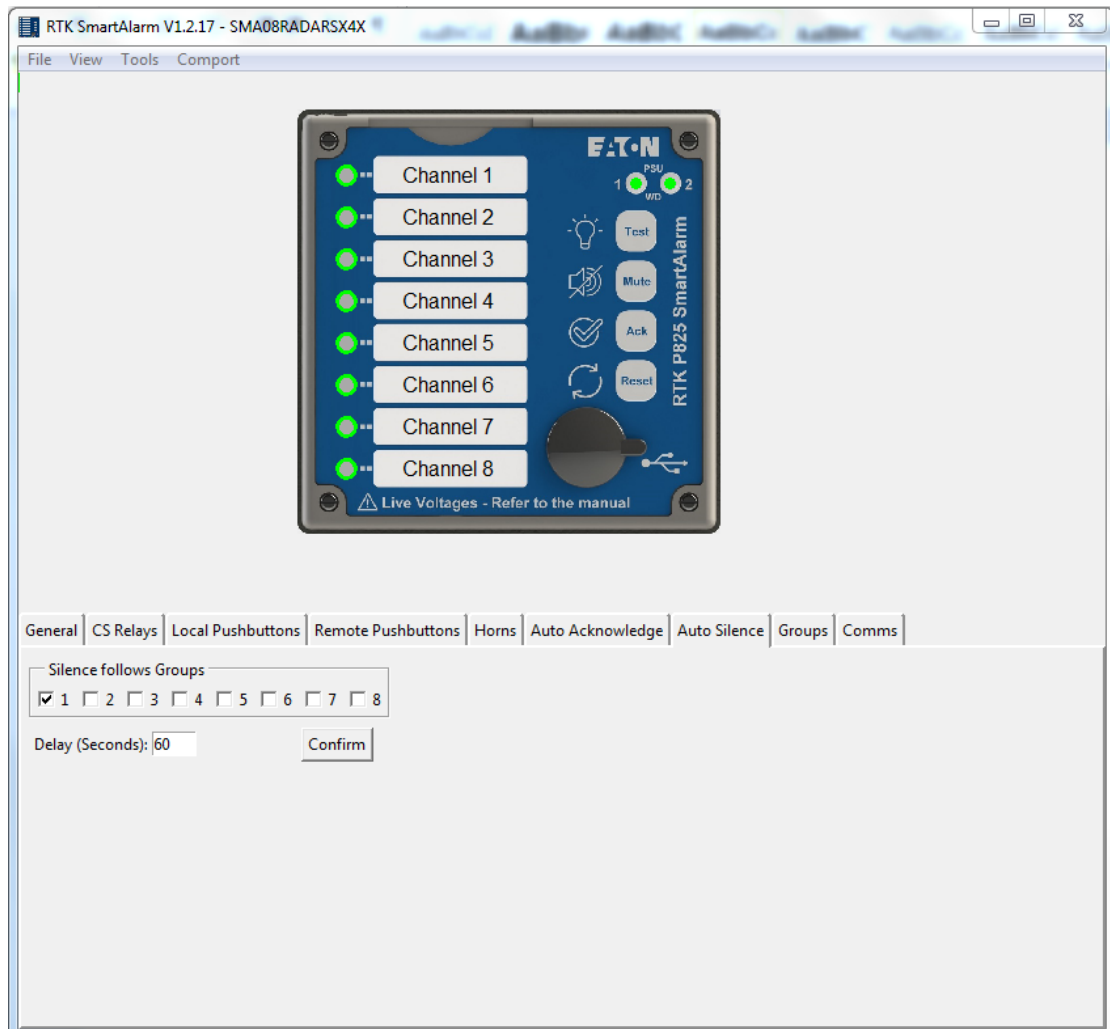

In the above example ALL channels have be set to “Group 1”

Assigning the Group Type

Grouping Example 1

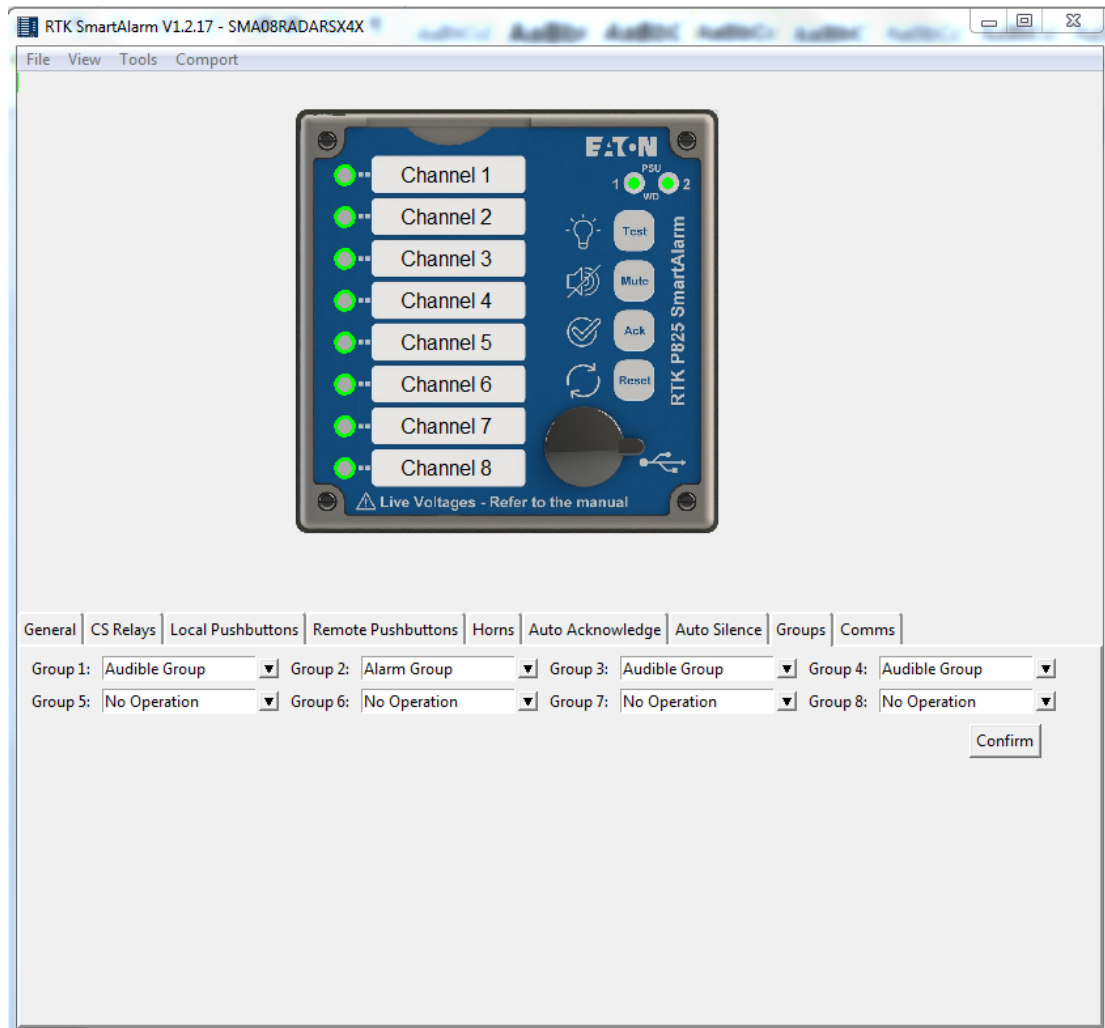

In the above example the “Group Type” has been set to Audible.

Assigning a Group to the Internal Audible

Grouping Example 2

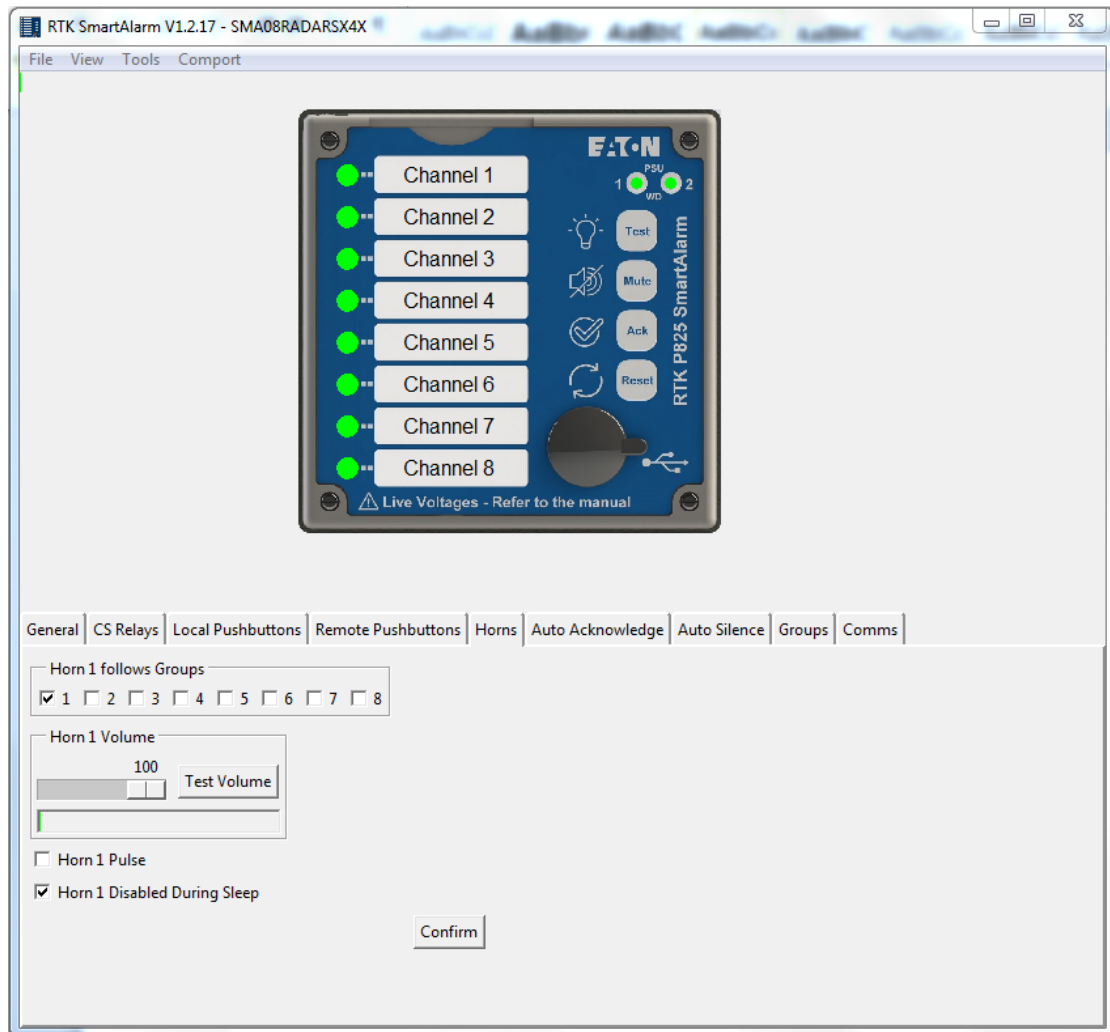

In the above example the internal horn has been set to follow "Group 1"

Assigning a Group to a Common Relay

Grouping Example 3

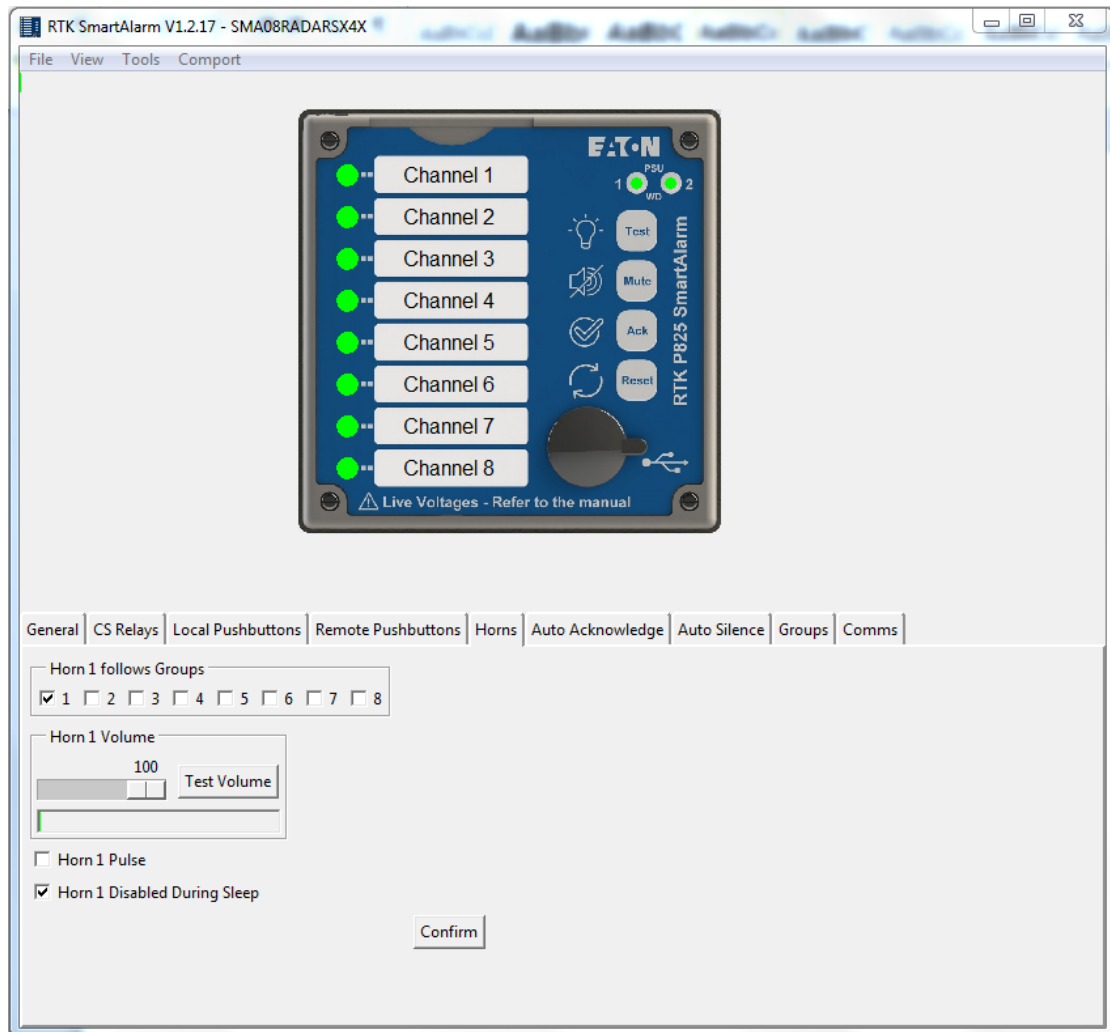

In the above example Common Relay Horn A / HNA has been set to follow "Group 1"

Communications

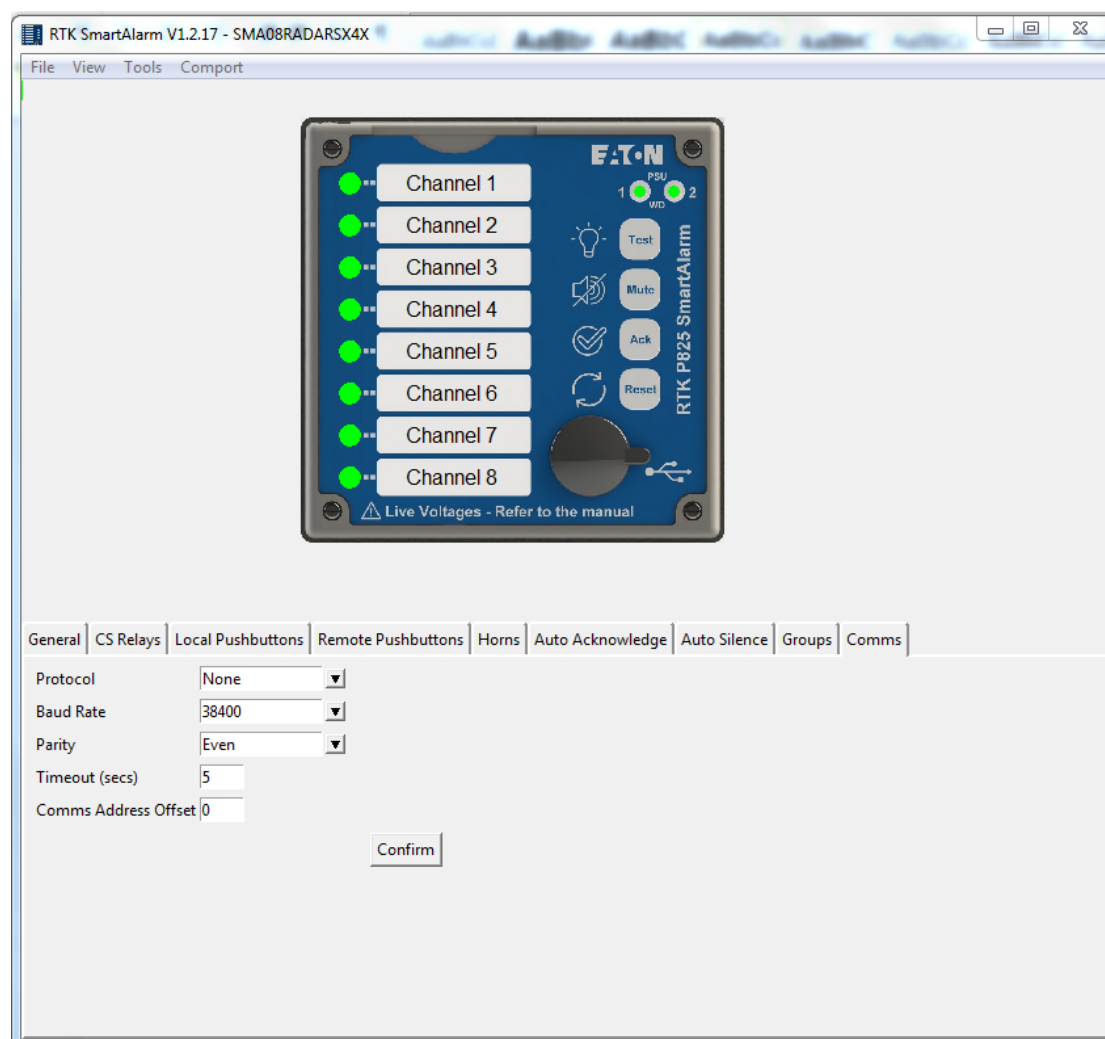

As an option the Annunciator can be provided with Modbus RTU Protocol for use with 3rd Party devices.

When this option is included the Comm's – Tab provides access to the fields used to set the following:-

- Protocol – Modbus RTU
- Baud Rate – 38400, 19200 or 9600
- Parity – Even or Odd
- Normal Delay – Set in mS
- Communications Address Offset – Set as required to match the 3rd Party device

17 INDIVIDUAL CHANNEL SETTINGS

Configuring Individual Channels

To configure individual channels the user must first select an LED on the associated annunciator faceplate using a left mouse click as typically shown below for channel-1.

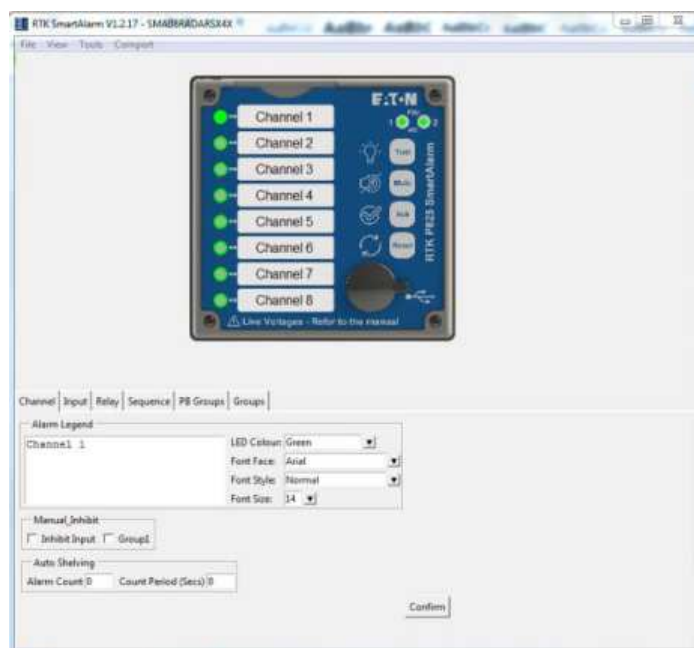

Configuring Selective channels

Selective channels can be highlighted if the “Ctrl” key on the keyboard is held down while you select the required LED icons (Channels). Once the channels have been selected the user is able to navigate between features and select them as required. The background colour for a selected feature is white however if the background colour changes to blue it indicates that the selected channels currently have varying settings stored and the user will be prompted if they wish to proceed in setting them to the same function.

Configuring Multiple channels

Multiple channels can be highlighted if the user selects the first LED and holds down the shift –key on the keyboard to select the last LED in the group. For example if you select channel-1 and hold down the shift-key and select channel-8 all channels within the range will be selected.

To implement changes the user must select the “Confirm” icon and download the configuration to the SmartAlarm using the “Tools” menu – “Send Settings” as required

Channel

The following options are available “Channel” tab

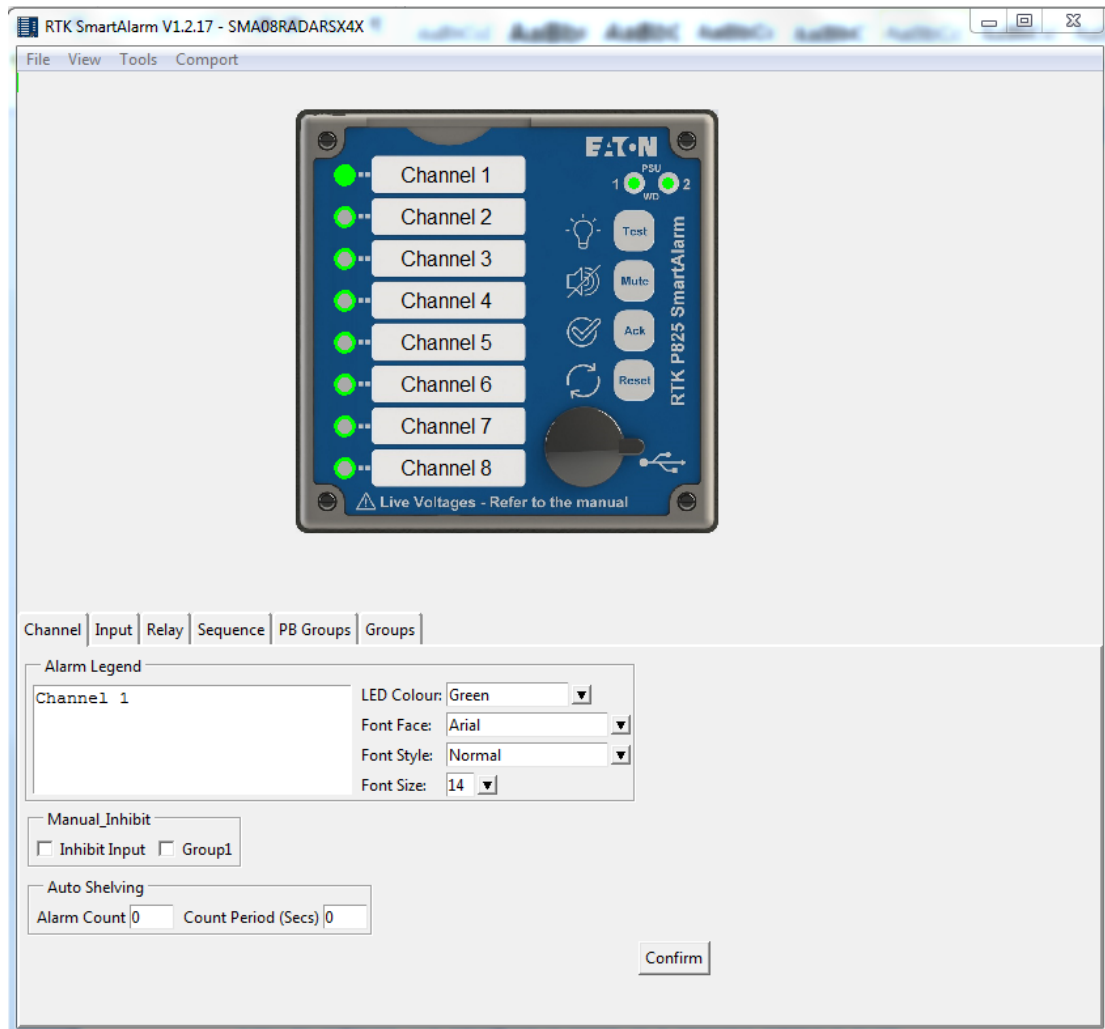

Alarm Legend

Each channel needs to have a unique legend to help the operator identify the alarm. The user can type an alarm description into the “alarm legend” field and dropdown menus allow selection of window colour, font, style and size to suit each application.

Manual Inhibit

Each channel can be manually inhibited within the software or a number of channels can be assigned to an inhibit group to allow a remote switch input to be used as a group inhibit enable. To manually inhibit a channel the user selects the associated LED icon and then uses a left mouse click to select the inhibit input tick-box under the channel tab.

Group Inhibit

If inhibit groups are required channels should be selected to the required group and the group should be assigned to a remote pushbutton/switch input as described later in the manual.

To implement changes the user must select the “Confirm” icon and download the configuration to the SmartAlarm using the “Tools” menu – “Send Settings” as required

Auto Shelving

On systems supplied with the sequence of event recording option a faulty alarm loop or loose cable can quickly flood the associated event buffers. Auto Shelve allows the user to configure:

Function	Description
Alarm Count	The maximum number of alarms the user believes will occur with a set period before the alarm count is considered abnormal.
Count Period	The required time period in seconds

If the number of input events exceeds the abnormal count within the time period the input will be automatically shelved and a dated and timed message will be generated to inform the user that auto shelving has occurred on the specific channel. Events that occurred prior to the auto shelve are stored in buffer to aid fault finding and the alarm will return to normal once the input is within operating parameters.

To implement changes the user must select the “Confirm” icon and download the configuration to the SmartAlarm using the “Tools” menu – “Send Settings” as required

Input

The following options are available under the “Input” tab

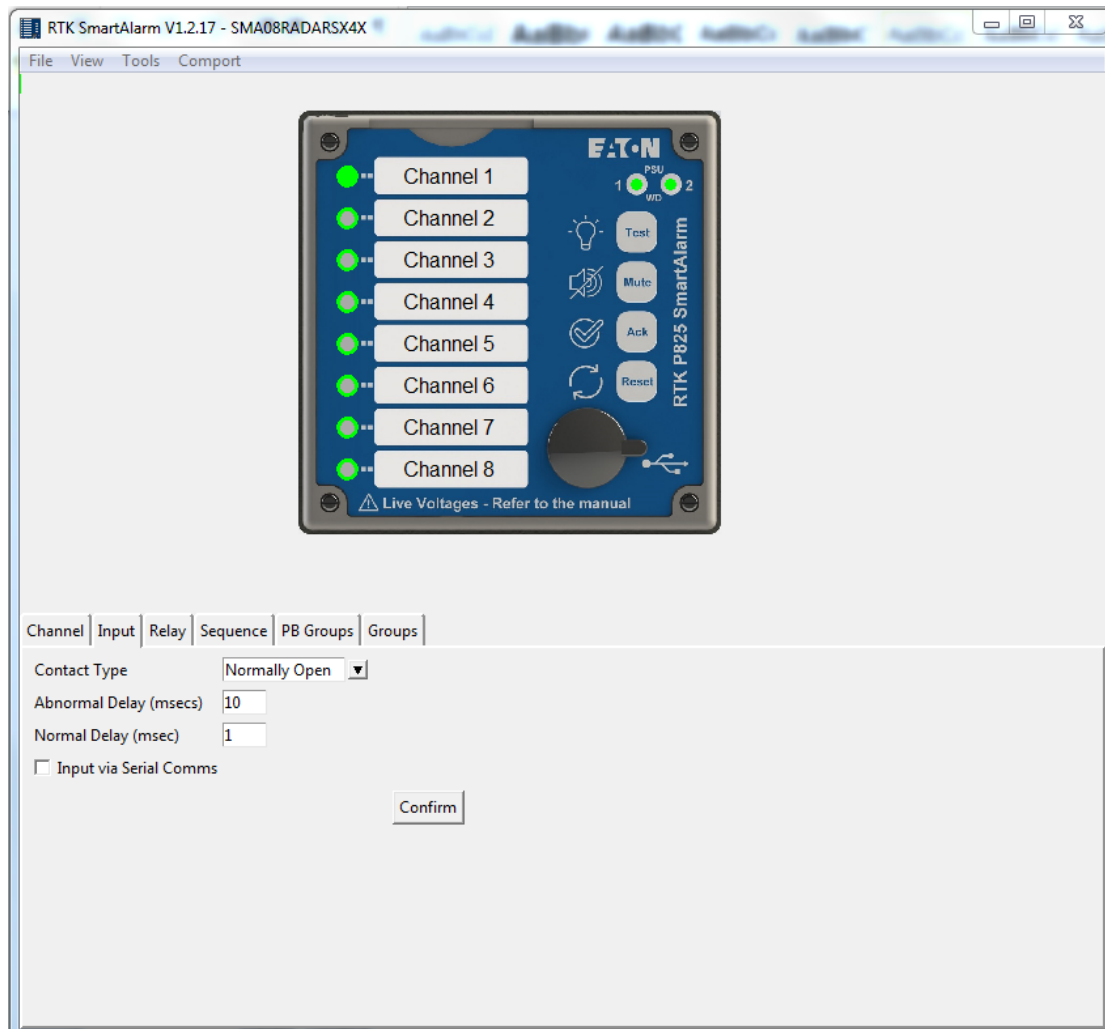

Contact Type

A dropdown menu allows the user to assign the non-alarm contact state for each channel. The default setting is Normally Open (Closed to alarm) with an optional setting to Normally Closed (Open to alarm). If serial inputs are required please select the tick-box to the left of “Remote”

Delay Timers

Each channel is equipped with timers allowing the user to delay the activation and/or the return to normal time period.

Abnormal Delay (mS)

This option prevents the alarm occurring before a pre-set time period has elapsed. If an alarm occurs the timer will automatically start and the alarm will occur as soon as the delay period has passed.

Normal Delay (mS)

This option prevents the alarm returning to normal until the pre-set delay period has elapsed.

The default setting for the activation and deactivation is 10mS but can be selected between 1 and 65,000mS as required.

Remote

This field is used to configure each input as hardware (Normally Open / Normally Closed) or Serial Input (Remote).

If the “Remote” check-box is enabled the input will activate via Serial Communications.

If the “Remote” check-box is unchecked the input will activate via a conventional hardwired contact input (N/O or N/C).

To implement changes the user must select the “Confirm” icon and download the configuration to the SmartAlarm using the “Tools” menu – “Send Settings” as required

Relay

As an option which must be specified at time of order, each channel can be provided with a repeat relay on the 8, 16 and 24 way versions of the SmartAlarm.

- If the relay tab is greyed out repeat relays have not been fitted.
- If the relay tab is active the following settings are available.

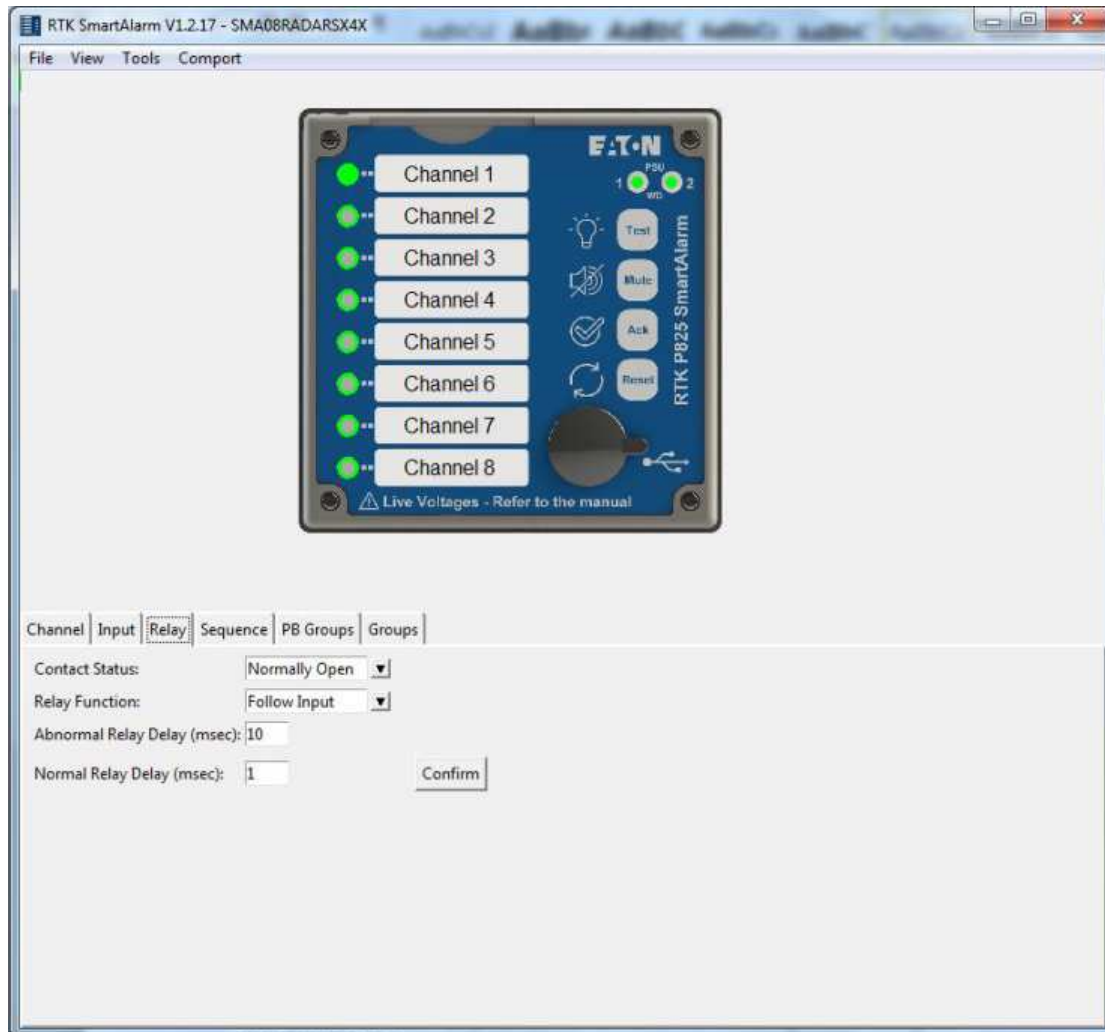

Coil Status

The non-alarm coil state of each relay can be set to Normally Energised or Normally De-Energised using the dropdown menu as required.

Relay Function

The function of each relay can be set to one of the following modes using the dropdown menu:-

- **Follow Input**
In this mode the relay will operate when the signal contact activates and returns to normal.
- **Follow Alarm**
In the mode the relay will activate on alarm and will only change state when the input returns to normal and the alarm has been cleared.
- **Follow Display**
In this mode the relay will faithfully follow the display i.e. ON / OFF or Flashing to match the alarm sequence.

Abnormal Delay

Each repeat relay can be set to activate after a pre-set time has elapsed.

The default is 10mS and the user can increment this in 1mS steps upto a maximum of 65,000mS.

Normal Delay

Each repeat relay can be prevented from returning to normal unless the change in state has occurred for longer than the pre-set time period.

The default is 10mS and the user can increment this in 1mS steps upto a maximum of 65,000mS.

To implement changes the user must select the “Confirm” icon and download the configuration to the SmartAlarm using the “Tools” menu – “Send Settings” as required

Sequence

The following settings are available under the “Sequence” tab

Within the annunciator market a common standard has been adopted by all key manufacturers and end users with regards to operational sequences. These standards are used worldwide to define the visual indication, audible alarm and the action the operator must take to control the annunciator.

The Instrument Society of America provide full details of each alarm sequence within ISA 18.1-1979 (R1992) and Eaton are fully compliant with the stated sequences. The most common sequences are detailed in a separate section of the manual.



ISA Sequences

To define a sequence the user can simply select any of the listed ISA sequences on a per channel basis using the dropdown menu as shown below.

The additional features shown i.e. Basic Sequence, First-Up Sequence and Sequence Options are only visible when the user selects view-“Advanced” and these options are used for custom sequences.

To implement changes the user must select the “Confirm” icon and download the configuration to the SmartAlarm using the “Tools” menu – “Send Settings” as required

PB Groups

The following settings are available under the “PB Groups” tab.

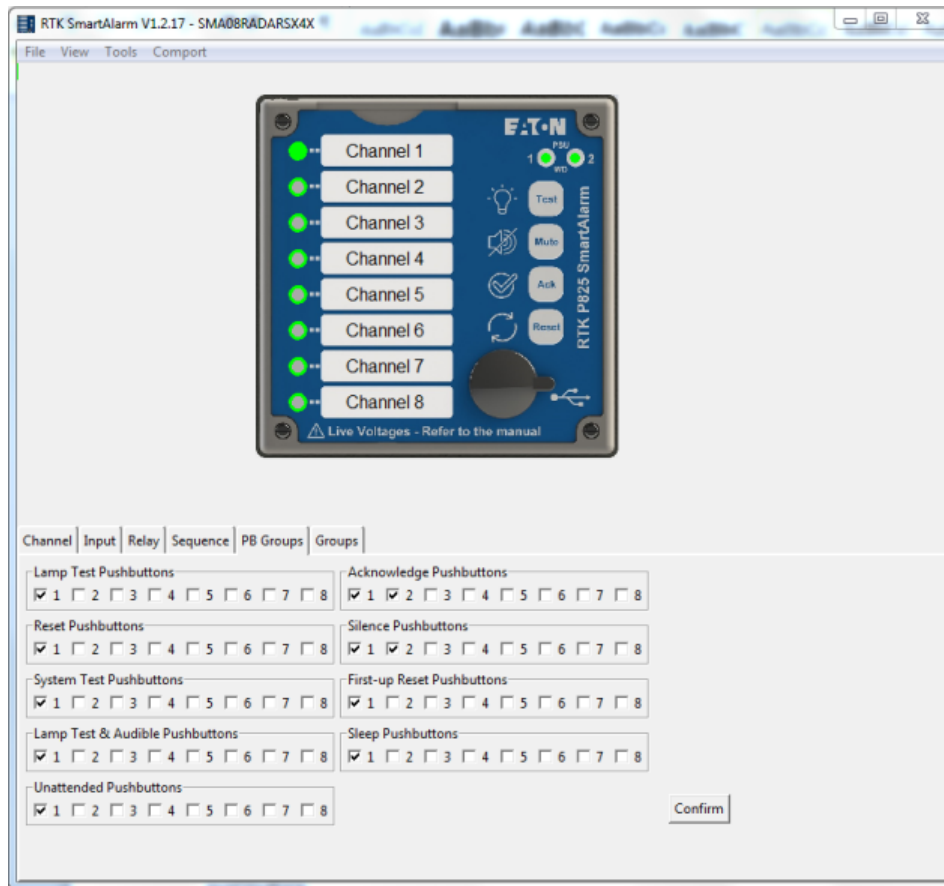

Global Pushbutton Group

Pushbutton functions are available within the SmartAlarm to test or control the alarms in accordance ISA-S18.1 Alarm Sequences.

In standard applications all channels are assigned to pushbutton group-1 however, the user can enable or disable any of the functions on a per channel basis as required.

Multiple Pushbutton Groups

In more complex applications each channel can be assigned to any one of 8 pushbutton groups. To access the additional groups the user must select “View” followed by “Advanced” view.

As a default Pushbutton Group-1 is assigned to the internal pushbuttons and any additional pushbutton groups would require the use of external pushbuttons.

To implement changes the user must select the “Confirm” icon and download the configuration to the SmartAlarm using the “Tools” menu – “Send Settings” as required

Groups

The following settings are available under the “Groups” tab.

Each channel within the SmartAlarm can be linked to a single or multiple alarm groups. Groups-1 to 8 are shown as standard and additional groups are available via the “View” – “Advance View” menu.

Groups are typically used to provide summary alarm information for use with 3rd Party devices (DCS/PLC/SCADA/Supervisor Consoles).

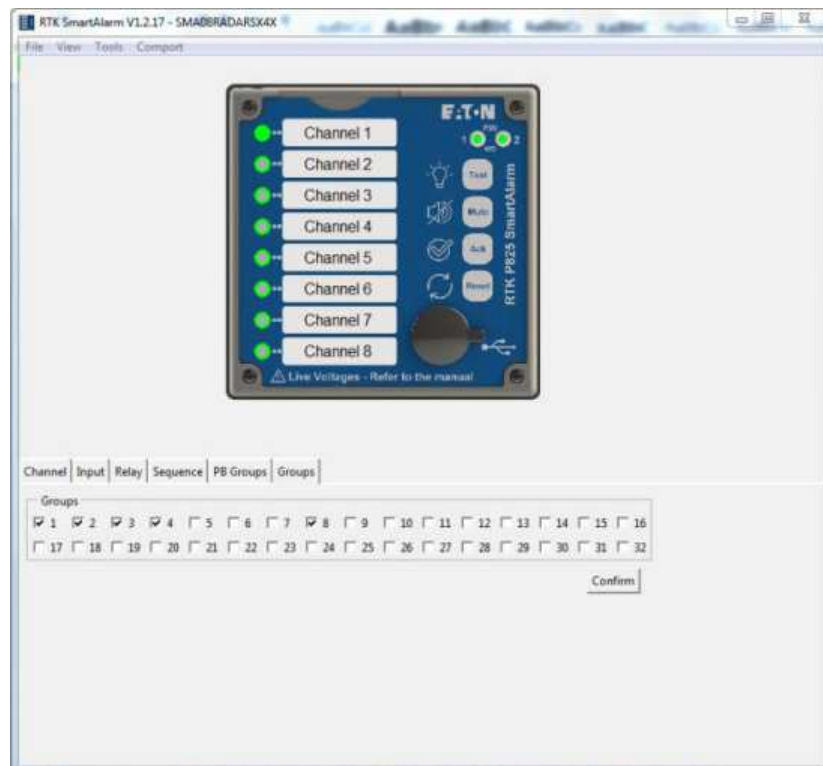

Channels can be assigned to a single or multiple groups using a left mouse click on the associated tick-box.

To implement changes the user must select the “Confirm” icon and download the configuration to the SmartAlarm using the “Tools” menu – “Send Settings” as required

18 ALARM SEQUENCES

Within the annunciator market a common standard has been adopted by all key manufacturers and end users with regards to operational sequences. These standards are used worldwide to define the visual indication, audible alarm and the action the operator must take to control the annunciator.

The Instrument Society of America provide full details of each alarm sequence within ISA 18.1-1979 (R1992) and Eaton are fully compliant with the stated sequences. The most common sequences are detailed within this section of the manual.

To define a sequence the user can simply select any of the listed ISA sequences.

Pushbuttons

Four integral pushbuttons and five remote pushbutton inputs are provided on the annunciator unit to allow the user to be able to control any of the available sequences which can be set on a per channel basis.

Functional Test – is used to simulate an input on all channels and therefore all windows and horn circuits will operate in accordance with the selected ISA sequence and additional pushbuttons will need to be pressed to step through the alarm sequence to return the unit to its normal state.

Mute – is used to silence the audible alarm whilst allowing the associated alarm window to continue to operate in accordance with the selected ISA sequence.

Acknowledge – is used to silence the alarm and change the state of the associated alarm window in accordance with the selected ISA sequence.

Reset – is used to return the alarm to the normal off state once the Input has returned to the normal condition.

As an option functional test can be replaced by Lamp Test and Reset can be replaced by First Reset if required.

Audible Alarms

Each channel within the annunciator can be set to operate either of the two integral audible alarms or they can be assigned to common relays configured as horn relays as required.

Additional Features

Automatic Reset

Once a channel has been acknowledged and its input has returned to normal the alarm can be set to automatically reset without the operator having to press the reset pushbutton.

Non Latch Sequence – (No Lock In)

Alarms can be set to non lock-in, which allows the alarm to automatically return to the non alarm state as soon as the signal input returns to normal.

Ringback Sequence

Ringback sequence is used to inform the operator both visually and audibly that an alarm condition has cleared and the channel can be reset to its normal off state. When a contact returns to normal the associated window will flash at approx ½ the speed of a normal alarm and the audible will sound. This identifies the specific alarm and informs the operator that the alarm can be reset to its normal off state.

First Up Sequences

When monitoring devices with interlinked functions such as a turbine or compressor it is often important to know the specific alarm that occurred first, as it will invariably result in cascade of secondary alarms. This allows the operator to focus on the root cause of failure and therefore limits the downtime and associated costs. This is achieved by having the first-up alarm flashing in a different manner compared to the subsequent alarms. Four different first-up sequences are available F0, F1, F2 and F3 as detailed below and in the following sequence tables.

F0 The standard mode adopted by Eaton Electric, which indicates the first-up alarm by flashing at twice the rate of subsequent alarms.

F1 In this mode subsequent alarms appear in the acknowledged state, hence they do not flash. The audible device does not operate when subsequent alarms occur, unless still operating from the first alarm. The acknowledge pushbutton will reset the first-up indication.

F2 In this mode all subsequent alarms do not flash, they will however operate the audible device. The acknowledge pushbutton will reset the first-up indication.

F3 In this mode initial alarms appear with an intermittent flash rate and subsequent alarms flash at a steady rate. On acknowledge subsequent alarms revert to the steady on state and only the first alarm continues to flash at a slower rate.

Please note auto reset and non lock- in functions are not recommended when using first up sequences as the true sequence of events cannot be guaranteed.

The most common sequences are detailed below:-

ISA A – Automatic Reset – Lock In

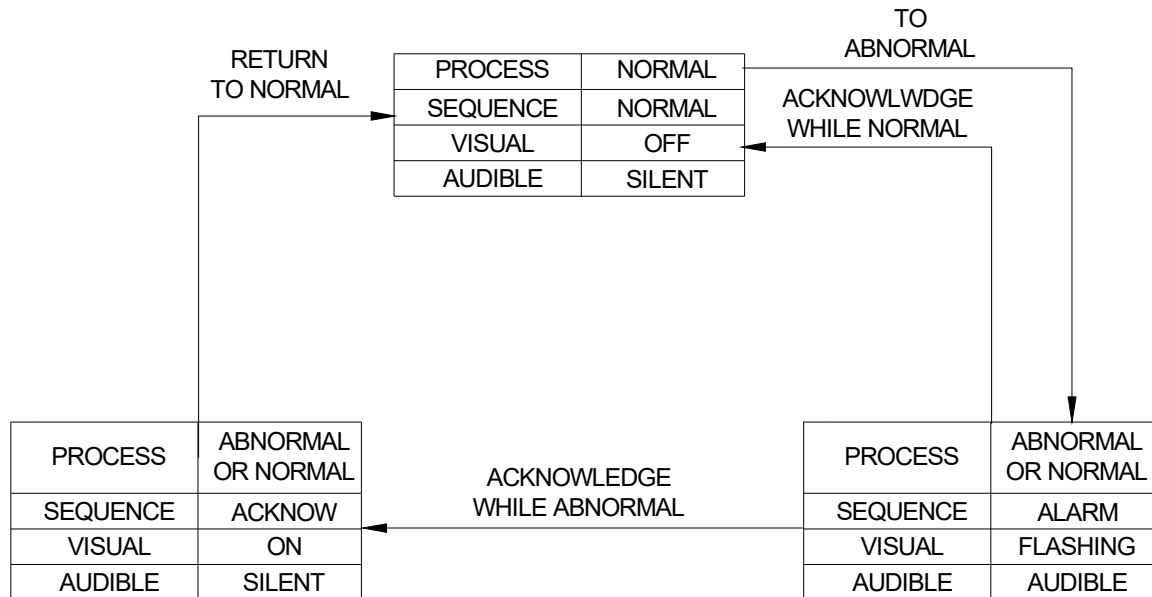

Sequence Features

1. Acknowledge and test pushbuttons.
2. Alarm audible device
3. Lock In of momentary alarms until acknowledged
4. The Audible device is silenced and the flashing stops when acknowledged.
5. Automatic reset of acknowledged alarms when the process has returned to normal
6. Operational test

ISA A-1-2 – Automatic Reset – Silence Pushbutton Interlock

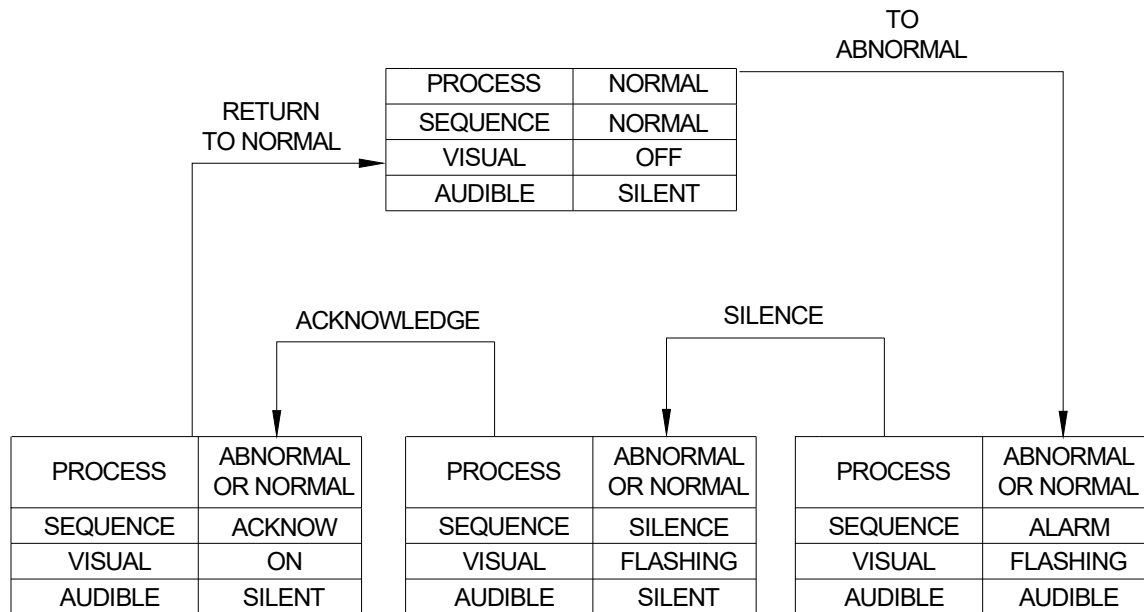

Sequence Features

1. Acknowledge, silence and test pushbuttons.
2. Alarm audible device
3. Lock In of momentary alarms until acknowledged
4. Silence pushbutton must be pressed before acknowledge
5. Silence stops the audible alarm only
6. The flashing stops when acknowledged.
7. Automatic reset of acknowledged alarms when the process has returned to normal
8. Operational test

ISA A-4 – Automatic Reset – Non Lock In

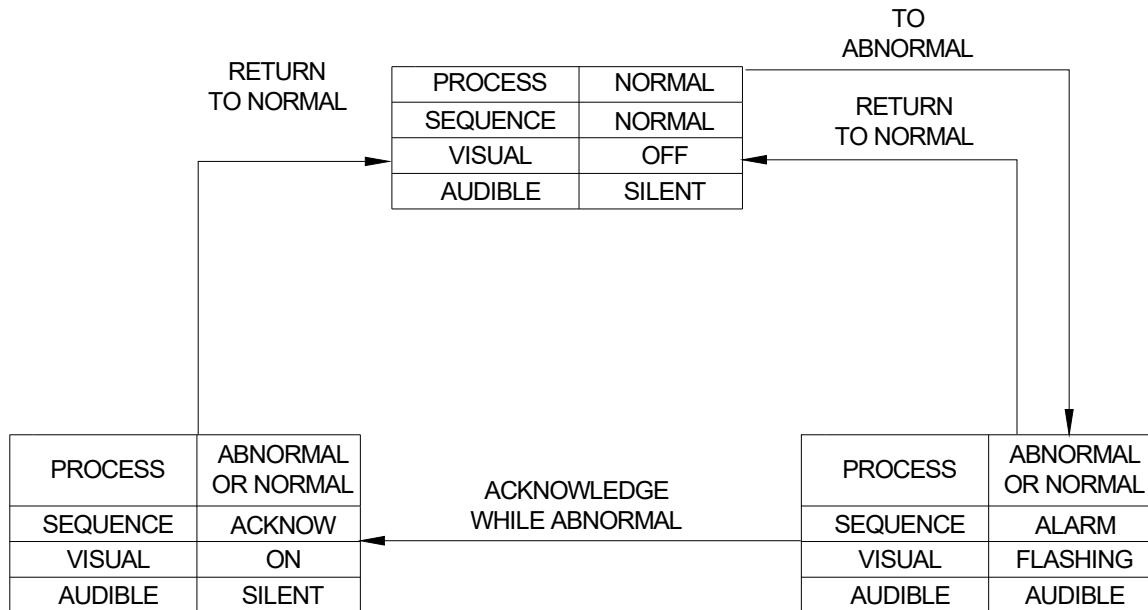

Sequence Features

1. Acknowledge, and test pushbuttons.
2. Alarm audible device
3. Non Lock In of momentary alarms
4. The audible device is silenced and the flashing stops when acknowledged.
5. Automatic reset of alarms when the process has returned to normal before or after acknowledge (Non Lock In)
6. Operational test

ISA A-4-5 – Automatic Reset – No Flashing

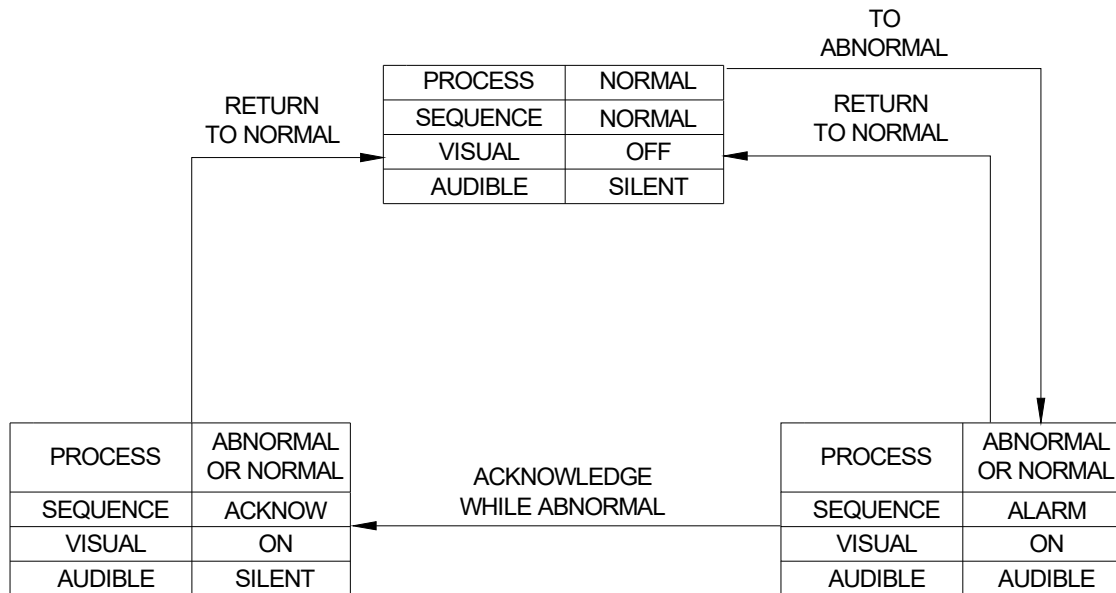

Sequence Features

1. Acknowledge, and test pushbuttons.
2. Alarm audible device
3. The visual alarm does not flash
4. Non Lock In of momentary alarms
5. The audible device is silenced when acknowledged.
6. Automatic reset of acknowledged alarms when the process has returned to normal
7. Operational test

ISA A-4-5-6 – Status

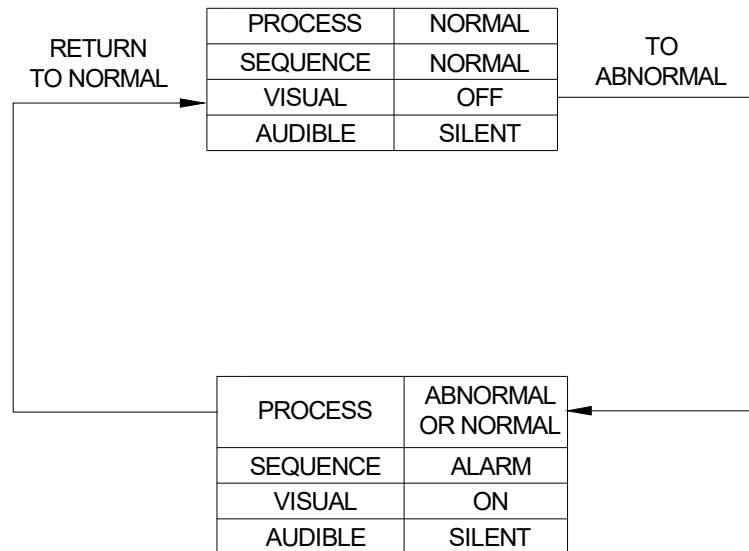

Sequence Features

1. Test pushbutton.
2. No alarm audible
3. The visual alarm does not flash
4. Non Lock In of momentary alarms
5. Automatic reset of alarms when the process has returned to normal before or after acknowledge (Non Lock In)
6. Operational test

Please Note:-

The drop down menu within the configuration software allows the user to select ISA Sequence A-4-5-6 to obtain Status Only indication.

If the audible alarm sounds on a channel that has been set to Status only please check that the channel is not part of a “Group” which has been assigned to operate as an “Audible” under the group operations tab.

In the example below Group 8 is being used as an audible group.

Group Tab

This screen shot indicates that a channel has been set to Group 8.

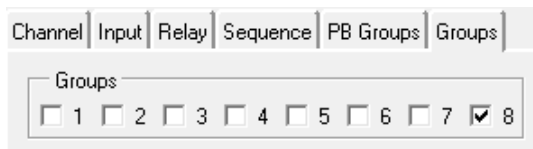

Group Operations Tab

This screen shot indicates that Group “Type” for Group 8 has been set to operate as “Audible”.

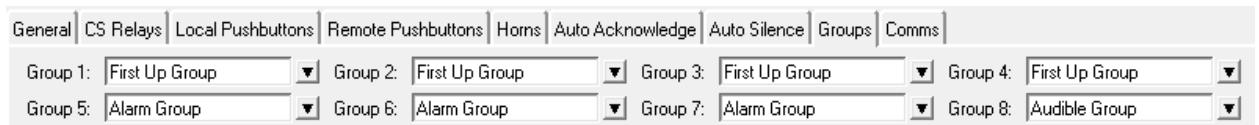

To prevent the audible sounding the user should select the associated alarm LED on the software faceplate and uncheck the tick box associated with any Group being used as an Audible in the example above this would be Group 8.

ISA A-5 – Automatic Reset – No Flash

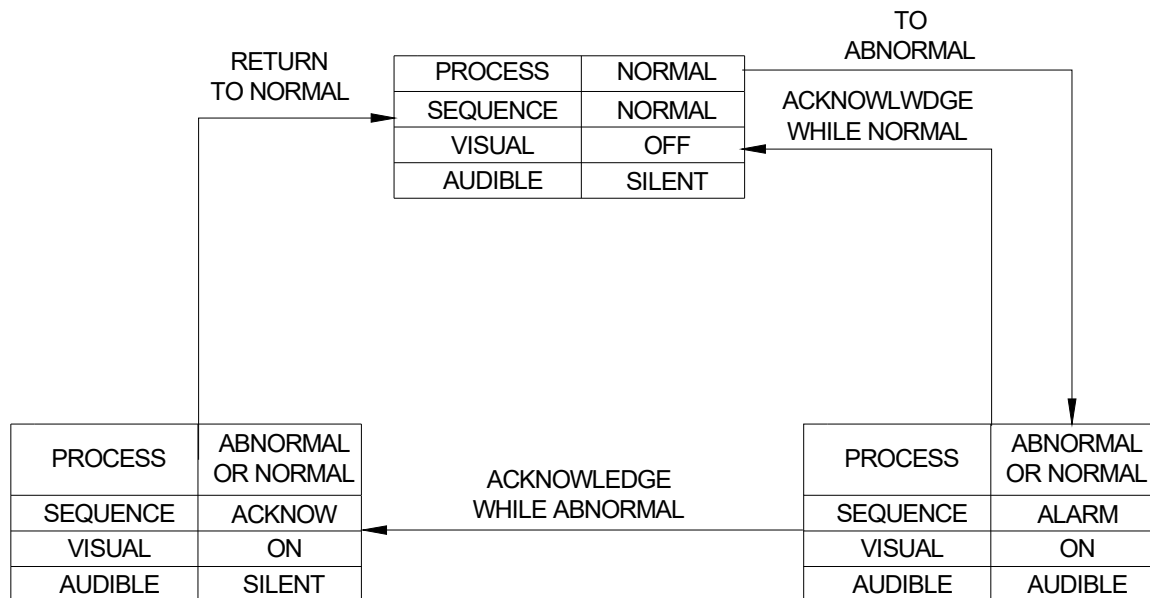

Sequence Features

1. Acknowledge and test pushbuttons.
2. Alarm audible device
3. The visual alarm does not flash
4. Lock In of momentary alarms until acknowledged
5. The Audible device is silenced when acknowledged.
6. Automatic reset of acknowledged alarms when the process has returned to normal
7. Operational test

ISA M – Manual Reset – Lock In

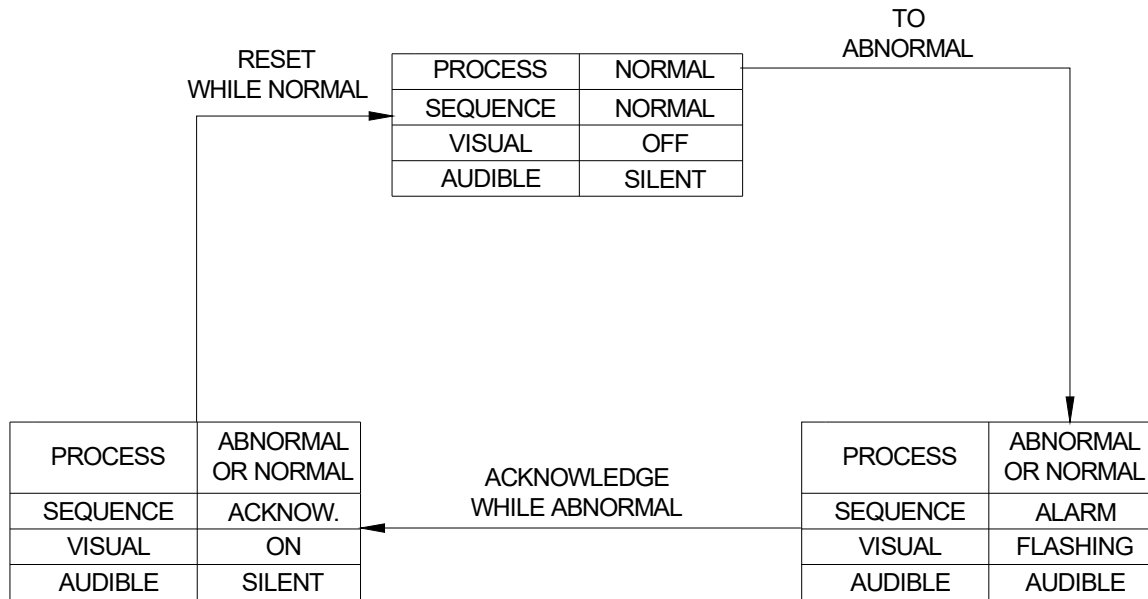

Sequence Features

1. Acknowledge, reset and test pushbuttons.
2. Alarm audible device
3. Lock In of momentary alarms until acknowledged
4. The Audible device is silenced and the flashing visual alarm stops when acknowledged.
5. Manual reset of acknowledged alarms when the process has returned to normal
6. Operational test

ISA M-1-2 – Manual Reset – Silence Pushbutton Interlock

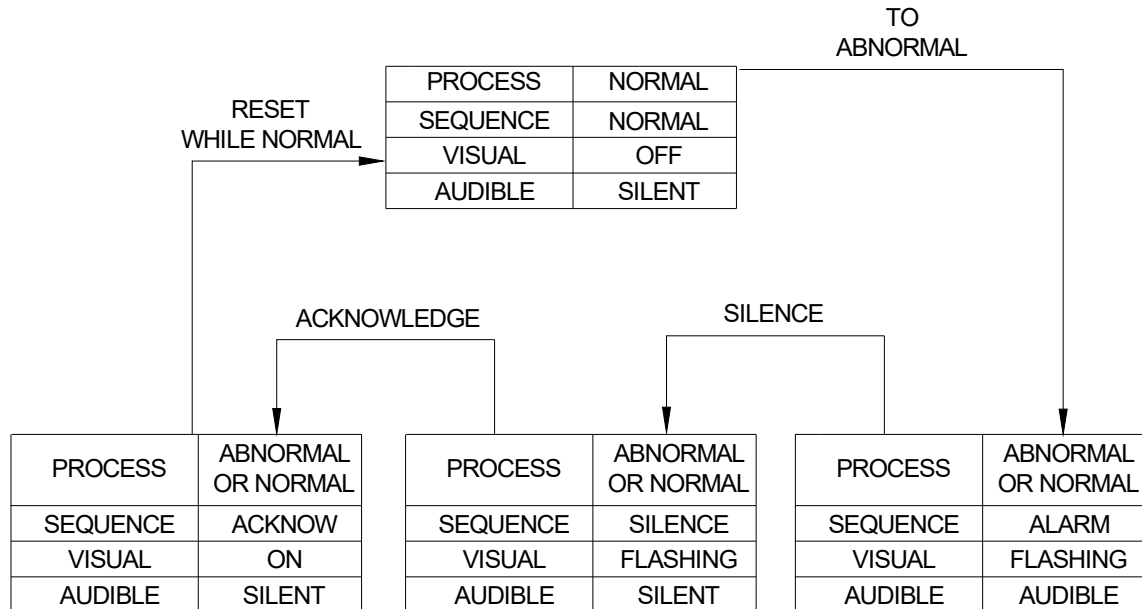

Sequence Features

1. Acknowledge, reset and test pushbuttons.
2. Alarm audible device
3. Lock In of momentary alarms until acknowledged
4. Silence pushbutton must be pressed before acknowledge
5. Silence stops the audible alarm only
6. The flashing stops when acknowledged.
7. Manual reset of acknowledged alarms when the process has returned to normal
8. Operational test

ISA R – Ringback

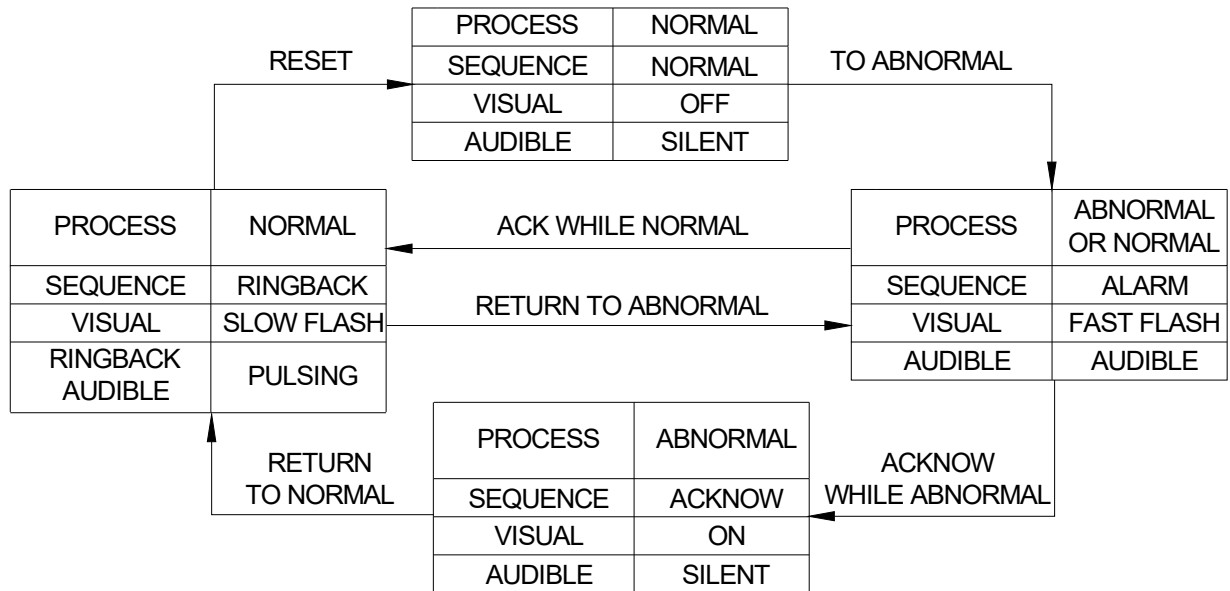

Sequence Features

1. Acknowledge, reset and test pushbuttons.
2. Alarm audible device. (optional Ringback audible device)
3. Lock In of momentary alarms until acknowledged
4. The audible device is silenced and the flashing stops when acknowledged
5. Ringback visual and audible indications when the process condition returns to normal
6. Manual reset of Ringback indications
7. Operational test

ISA F1A-1 – Automatic Reset First Up

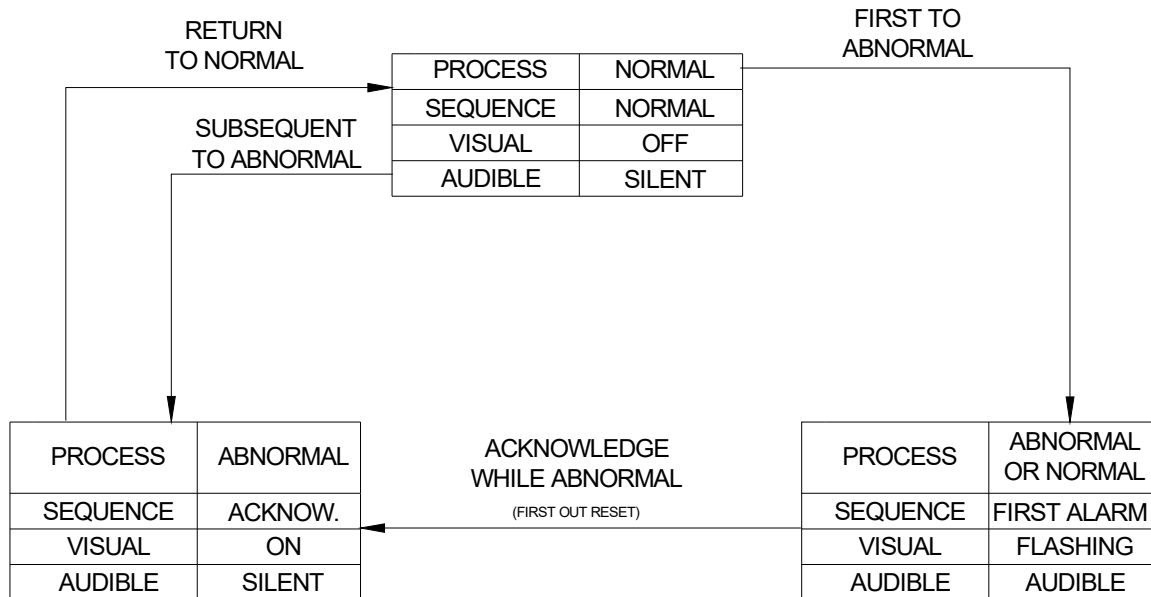

Sequence Features

1. Acknowledge and test pushbuttons.
2. Alarm audible device
3. Lock In of momentary first alarm only, no lock in of momentary subsequent alarms
4. Flashing and audible indications for first alarm only, new subsequent alarms go to the acknowledge state.
5. First out indication is reset and the audible is silenced when acknowledged.
6. Automatic Reset of acknowledged alarm indications when the process returns to normal
7. Silence pushbutton can be used to silence the audible alarm only

ISA F2M-1 – Manual Reset First Up

SEQUENCE DIAGRAM

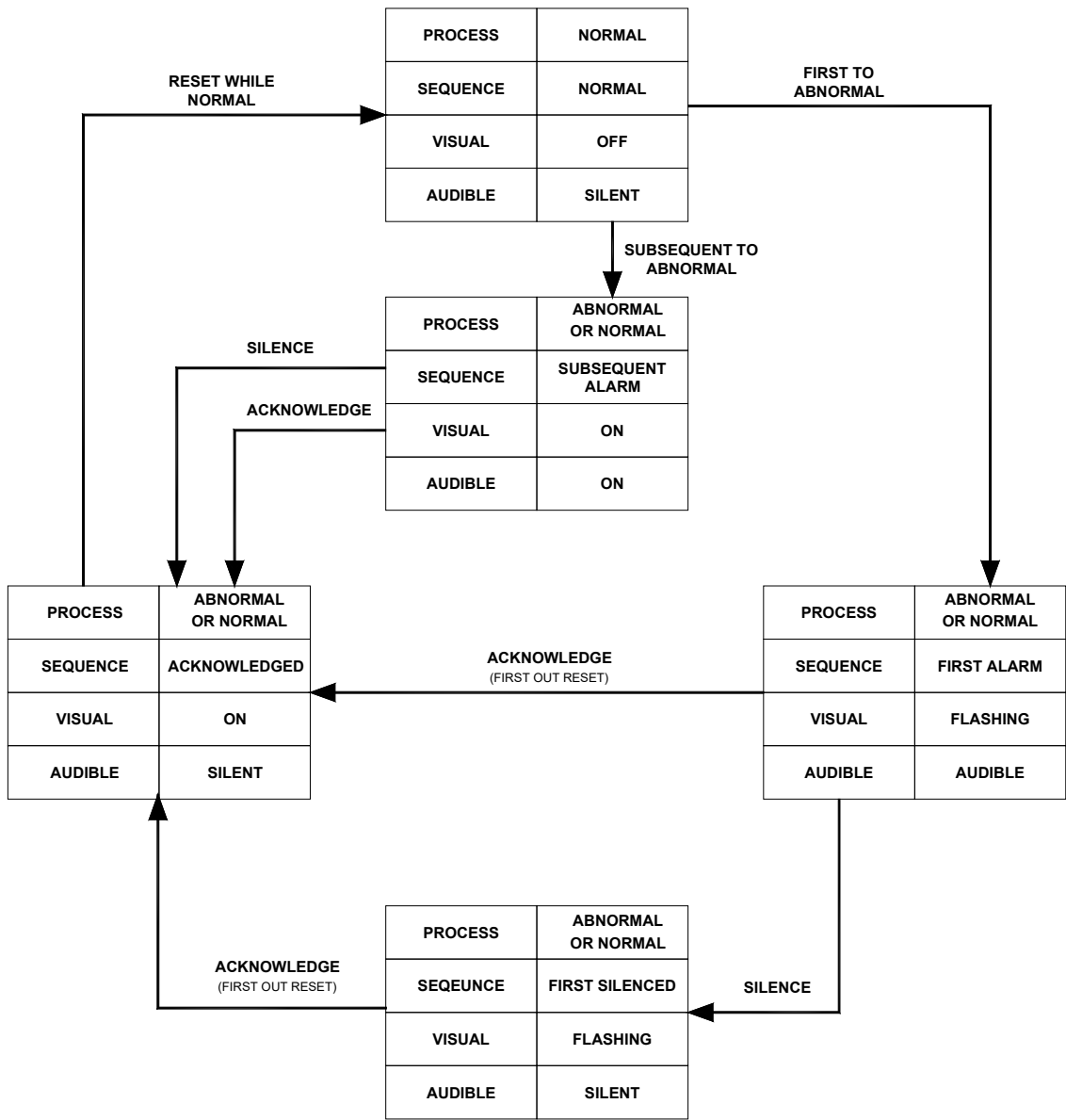

SEQUENCE ISA F2M-1

(MANUAL RESET FIRST OUT WITH NO SUBSEQUENT ALARM FLASHING & SILENCED PUSHBUTTON)

LINE	PROCESS CONDITION		PUSHBUTTON OPERATION	SEQUENCE STATE	VISUAL DISPLAY	ALARM AUDIBLE DEVICE	REMARKS
1	NORMAL			NORMAL	OFF	SILENT	
2	FIRST	ABNORMAL		FIRST ALARM	FLASHING	AUDIBLE	LOCK-IN
3	SUB.	ABNORMAL		SUB. ALARM	ON	AUDIBLE	LOCK-IN
4	FIRST	ABNORMAL OR NORMAL	ACKNOWLEDGE BEFORE SIL	TO LINE 7			FIRST OUT RESET
5	SUB.	ABNORMAL OR NORMAL					
6	FIRST	ABNORMAL OR NORMAL	SILENCE	FIRST SILENCED	FLASHING	SILENT	
7	SUB.	ABNORMAL OR NORMAL	SILENCE	ACKNOWLEDGE	ON	SILENT	MANUAL RESET REQUIRED
8	FIRST	ABNORMAL OR NORMAL	ACKNOWLEDGE AFTER SILENCE	TO LINE 7			FIRST OUT RESET
9	NORMAL		RESET	NORMAL	OFF	SILENT	MANUAL RESET

SEQUENCE FEATURES

1. Silence, acknowledge, reset and test pushbuttons
2. Alarm audible device
3. Lock-in of momentary alarms until acknowledged.
4. Option1 – silence pushbutton to silence the alarm audible device while retaining the first out flashing indication
5. Flashing indication for first alarm only. new subsequent alarms have the same visual indication as acknowledged alarms.
6. First out indication is reset when acknowledged
7. Manual reset of acknowledged alarm indications after process conditions return to normal.
8. Operational test

ISA F2A-1 – Automatic Reset First Up

This sequence is the same as ISA F2M-1 with the exception that the alarms are automatically reset once the process has returned to normal.

ISA F3A – Automatic Reset First Up

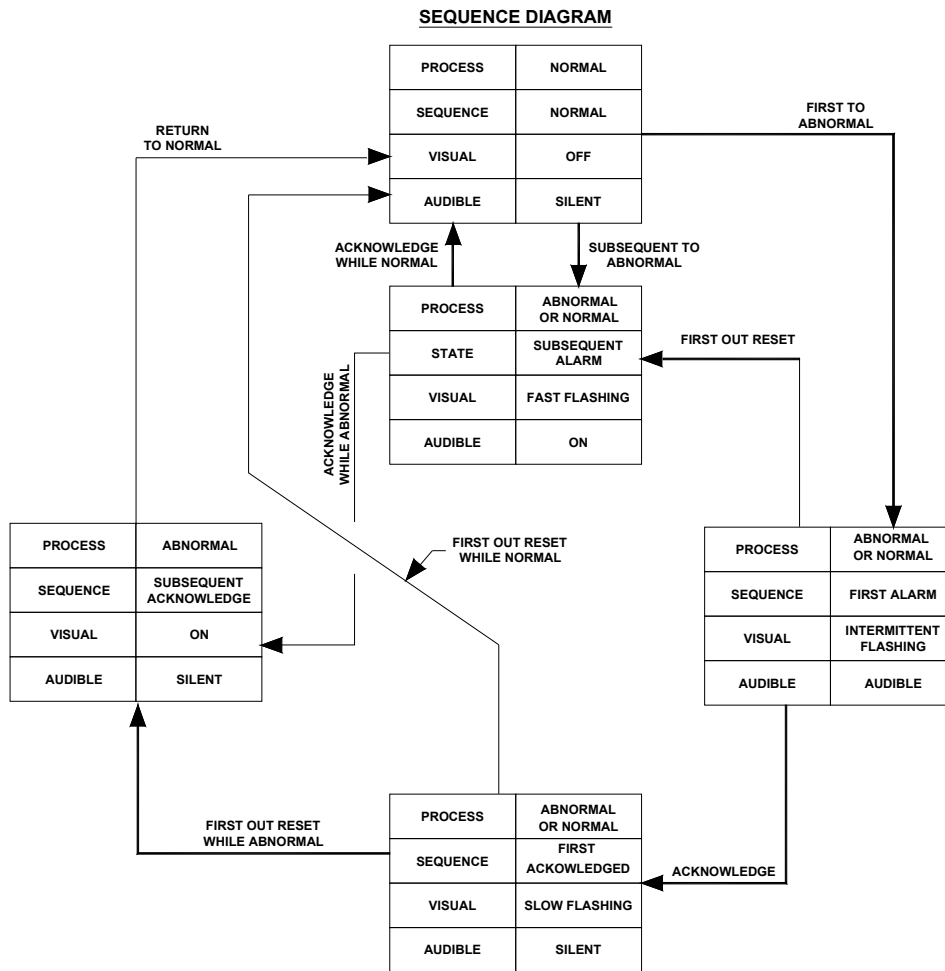

SEQUENCE ISA F3A
(AUTOMATIC RESET FIRST OUT WITHOUT FLASHING & RESET PUSHBUTTON)

SEQUENCE TABLE

LINE	PROCESS CONDITION		PUSHBUTTON OPERATION	SEQUENCE STATE	VISUAL DISPLAY	ALARM AUDIBLE DEVICE	REMARKS
1	NORMAL			NORMAL	OFF	SILENT	
2	FIRST	ABNORMAL		FIRST ALARM	INTERMITTENT FLASHING	AUDIBLE	LOCK-IN
3	SUB.	ABNORMAL		SUB. ALARM	FAST FLASHING	AUDIBLE	LOCK-IN
4	FIRST	ABNORMAL OR NORMAL	FIRST OUT RESET BEFORE ACKNOWLEDGE	TO LINE 3			FIRST OUT RESET
5	FIRST	ABNORMAL OR NORMAL	ACKNOWLEDGE	FIRST ACKNOWLEDGED	SLOW FLASHING	SILENT	FIRST OUT RESET REQUIRED
6A	SUB.	ABNORMAL		SUB. ACKNOWLEDGE	ON	SILENT	MAINTAINED ALARM
6B	SUB.	NORMAL		TO LINE 8			MOMENTARY ALARM
7A	FIRST	ABNORMAL	FIRST OUT RESET AFTER ACKNOWLEDGE	TO LINE 6A			FIRST OUT RESET
7B	FIRST	NORMAL		TO LINE 8			FIRST OUT RESET
8	NORMAL			NORMAL	OFF	SILENT	AUTOMATIC RESET

SEQUENCE FEATURES

1. Silence, acknowledge, reset and test pushbuttons
2. Alarm audible device
3. Lock-in of momentary alarms until acknowledged.
4. Flashing indication for first alarm only. New subsequent alarms have the same visual indication as acknowledged alarms.
5. First out indication is reset when acknowledged
6. Manual reset of acknowledged alarm indications after process conditions return to normal.
7. Operational test

ISA F3A-3 – First Out Reset Interlock

This sequence is the same as F3A with the addition of First Reset Interlock which requires acknowledge to be pressed before First Reset will function.

ISA F3M – Manual Reset First Out

This sequence is the same as F3A with the addition of Manual Reset. All alarms must be manually reset once the process has returned to normal.

ISA F3M-1-2 – Manual Reset First Out with Silence Interlock

This sequence is the same as F3A with the addition of Silence Interlock and Manual Reset.

The Silence pushbutton must be operated before alarms can be acknowledged. The Silence pushbutton stops the Audible alarm only.

All alarms must be manually reset once the process has returned to normal.

19 COMMUNICATIONS

Port 1

Connection Details

A standard RJ45 8P8C socket is provided on the rear of the SmartAlarm for systems equipped with the Modbus RTU option which provides the following connections:-

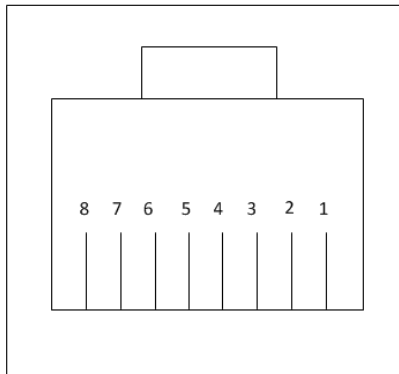

Port 1 Connection Details – Smart Alarm

1. No Connection
2. No Connection
3. GND
4. RxB
5. RxA
6. GND
7. TxA
8. TxB

MODBUS RTU

The tables below show the standard message formats for data interchange for Modbus RTU protocol.

RTU tables. Each character represents 8 bit binary data in hexadecimal format.
 Y represents a character with more than one possible value.
 All characters are framed with 1 start bit, 1 parity bit and 1 stop bit.

Read Request – Master

	START	ADDRESS	FUNCTION	REGISTER / COIL ADDRESS	NO. OF REGISTERS / COILS	ERROR CHECK	STOP
RTU	ELAPSED TIME 3 ½ CHARACTERS MIN	Y	Y	YY	YY	YY	ELAPSED TIME 3 ½ CHARACTERS MIN

Read Response - Slave

	START	ADDRESS	FUNCTION	BYTE COUNT	DATA	ERROR CHECK	STOP
RTU	ELAPSED TIME 3 ½ CHARACTERS MIN	Y	Y	Y	YY	YY	ELAPSED TIME 3 ½ CHARACTERS MIN

Single Write Request/Response

Master write request and slave write response, are the same.

	START	ADDRESS	FUNCTION	REGISTER / COIL ADDRESS	DATA	ERROR CHECK	STOP
RTU	ELAPSED TIME 3 ½ CHARACTERS MIN	Y	Y	YY	YY	YY	ELAPSED TIME 3 ½ CHARACTERS MIN

Multiple Write Request

RTU	START	ADDRESS	FUNCTION	REGISTER / COIL ADDRESS	QTY	BYTE COUNT	DATA	ERROR CHECK	STOP
	ELAPSED TIME 3 ½ CHARS MIN	Y	Y	YY	YY	Y	YY	YY	ELAPSED TIME 3 ½ CHARS MIN

Multiple Write Response

RTU	START	ADDRESS	FUNCTION	REGISTER / COIL ADDRESS	QTY	ERROR CHECK	STOP
	ELAPSED TIME 3 ½ CHARS MIN	Y	Y	YY	YY	YY	ELAPSED TIME 3 ½ CHARS MIN

Address

Each alarm card is addressed directly. On a typical 24Way SmartAlarm, first alarm card data is accessed using node address 1, second alarm card using node address 2 etc. As default the first node address starts at 1, this can be modified using the configuration software. Select View - Advanced then Comms tab and adjust the field marked "Comms Address Offset".

First card Node Address = 1 + Comms Address Offset.
 Second card Node Address = 2 + Comms Address Offset.
 Third card Node Address = 3 + Comms Address Offset.

Comms Address Offset default is 0.

Function

Modbus Function No.

Error Check

This defines the error checking format required, for Modbus RTU this should be set to CRC (Cyclic Redundancy Check)

Modbus Slave – Standard Communications

Function Descriptions

This section describes the process of reading from and writing data to a SmartAlarm annunciator.

Read Coil Status – Function 01 – Read Request – Master

Coil Address

This is used to address the “start” channel to be read, typically the first channel “channel 1” contact status on alarm card would be coil address 00 01

To read the contact status coils use address range 1- 8

To read the alarm status coils use address range 11- 18

To read the disable status coils use address range 21- 28

Number of Coils

This represents the number of coils (Channels) the master wishes to read. The range is 1- 8.

Read Coil Status – Function 01 – Read Response - Slave

Byte Count

This represents the number of data bytes sent

Data

Data returned depends on coil address originally specified by the master.

Coil address 1 - 8 returns Contact status data

0 = Contact Normal

1 = Contact Abnormal

Coil address 11 - 18 returns Alarm status data

0 = Alarm Normal

1 = Alarm Abnormal

Coil address 21 - 28 returns Disable status data

0 = Channel Enabled

1 = Channel Disabled

Typical Example of Message Format

To read all contact status data on a 24 way SmartAlarm the following message format has to be repeated 3 times, once for each alarm card node address.

RTU

ADDRESS	FUNCTION	REGISTER ADDRESS	No Of REGISTERS	ERROR CHECK
01	01	00 01	00 08	6C 0C

Example shows message for first card, Comms address offset 0.

Read Status – Function 03 – Read Request – Master

Register Address

This is used to address the “start” channel to be read, typically the first channel “channel 1” contact status on alarm card would be register address 40001

To read the contact status registers use address range 40001- 40008

To read the alarm status registers use address range 40011- 40018

To read the disable status registers use address range 40021- 40028

Number of Registers

This represents the number of registers (Channels) the master wishes to read. The range is 1- 8.

Read Status – Function 03 – Read Response - Slave

Byte Count

This represents the number of bytes sent

Data

Data returned depends on register address originally specified by the master.

Register address 40001 - 40008 returns Contact status data

0 = Normal

1 = Abnormal

Register address 40011 - 40018 returns Alarm status data

64	Alarm Event return to normal
65	Subsequent Alarm Event activated
66	First-up Alarm Event activated
67	Subsequent Alarm Event Acknowledged
68	First-up Alarm Event Acknowledged
69	Alarm Event Ring-back

Register address 40021 - 40028 returns Disable status data

2	Channel Shelved
3	Channel Disabled
4	Channel Unshelved
5	Channel Enabled
7	Channel Inhibited
8	Channel Uninhibited

Typical Example of Message Format

To read all contact status data on a 24 way SmartAlarm the following message format has to be repeated 3 times, once for each alarm card node address.

RTU

ADDRESS	FUNCTION	REGISTER ADDRESS	No Of REGISTERS	ERROR CHECK
01	03	9C 41	00 08	3A 48

Example shows message for first card, Comms address offset 0.

Write Multiple Coils – Function 15 - Read Request – Master

Coil Address

Indicates first coil address to be written. Typically the first channel contact status on an alarm card “channel 1” would be coil address 00 01.

To write the contact status coils use address range 1- 8.

Note: To initiate input status change via message 15 “Input via serial comms” must be selected for each channel. Selection is via the configuration software.

Quantity

This represents the number of coils (Channels) the master wishes to write

Byte Count

This represents the number of data bytes sent

Data

This represents the status of the coil to be written

0 = Contact Normal

1 = Contact Abnormal

Write Multiple Coils – Function 15 – Read Response - Slave

Coil Address

Indicates first coil address to be written. Typically the first channel contact status on an alarm card “channel 1” would be coil address 00 01.

Quantity

This represents the number of coils the master has written

Typical Example of Message Format

To write alternate contacts abnormal on a 24 way SmartAlarm where each alarm card is treated as an individual node. The following message format would have to be repeated 3 x times, once for each card node address.

RTU

ADDRESS	FUNCTION	REGISTER ADDRESS	No Of REGISTERS	BYTE COUNT	DATA	ERROR CHECK
01	0F	00 01	00 08	01	AA	43 2A

Example shows message for first card, Comms address offset 0.

20 SPECIFICATIONS

Primary power supply

- Universal Input Type capable of accepting 85 – 264VAC 50/60Hz or 88 to 300VDC

Optional version (Must be specified at time of order)

- 19 to 72VDC.

Aux power supplies

- Universal Input Type capable of accepting 85 – 264VAC 50/60 Hz or 88 to 300VDC.

Optional version (Must be specified at time of order).

- 19 to 72VDC.

CAUTION

Power supplies must be fused externally with a 1AT fuse or suitable MCB.

Maximum Power

The maximum power rating for the range of SmartAlarm unit 8 through to 24 channel is 8 Watts Maximum

Signal Inputs

- All inputs are provided with optical isolators capable of withstanding a 1000 volts megger test to ground.
- The standard unit provides an isolated +24VDC as a signal supply voltage and options exist for 24VDC, 48V DC, 125V AC/DC or 250V AC/DC.

Input response time

- The user can select the response time required per channel in the range 1ms to 65S using the Eaton supplied configuration software.

First-Up discrimination

- Better than 10mS.

Outputs

Individual channel repeat relays

As an option each channel within the Annunciator can be supplied with a dedicated low power magnetically latched pulse relay with a configurable N/O or N/C contact for use with 3rd Party devices.

Contact rating

Voltage	Rating (resistive)
24VDC	0.2A
110VDC	0.2A

HNA & HNB Horn Relays

Two horn relays are provided as standard HNA & HNB each providing a N/O contact for use with external horns or 3rd party devices.

Contact rating

Voltage	Rating (resistive)
30VDC	2A
125VAC	2A
115VDC	150mA

GPA & GPB Common Alarm Group Relays

Two common alarm group relays are provided as standard GPA & GPB each providing a configurable N/O or N/C contact for use with 3rd party devices.

Contact rating

Voltage	Rating (resistive)
24VDC	1A
110VDC	0.2A

Watchdog Relay

A single contact that can mapped to many functions via the software configurator, such as "All Faults", Pushbutton repeats, Comms Fault Etc.

Voltage	Rating (resistive)
24VDC	1A
110VDC	0.2A

Audible alarms

An integrally mounted 2.4Khz piezoelectric horn is provided as standard. Rated at 85db @ 30cm.

Communications

SmartAlarms can be provided with an isolated RS485 Comm's Port using Modbus RTU Protocol.

Environmental Specifications

Temperature

Operating Temperature - 20 to + 60 Degrees C

Storage Temperature - 20 to + 80 Degrees C

Humidity 0 – 95% RH, Non Condensing

Protection

Annunciator front: IP40

Annunciator rear: IP20

Optional front IP54

EMC Compliance

IEC61326-1: 2013

Radiated RFI Immunity

IEC 61000-4-3

Conducted RFI Immunity

IEC 61000-4-6

Radiated Emissions

IEC 61000-6-3

Conducted Emissions

IEC 61000-6-3

Radiated Power Frequency Magnetic Field

IEC 61000-4-8

ESD Effects

IEC 61000-4-2

Surge Withstand – Oscillatory

ANSI C37.90.1

Electrical Fast Transient/Burst Immunity

IEC 61000-4-4

Surge Immunity

IEC 61000-4-5

LVD

EN 61010-1-2010

21 SPARE PARTS LIST

Alarm Card Spares

Product Code	Description
P825-SPR-001	SmartAlarm Installation Spares Kit
P825-SPR-002	SmartAlarm Active Alarm card Spares MLPCBP82521-3 P825 ALM 24/125V PCB ASSY
P825-SPR-003	SmartAlarm Active Alarm card Spares MLPCBP82521-33 P825 ALM 24/125V PCB ASSY - CC
P825-SPR-004	SmartAlarm Active Alarm card Spares MLPCBP82522-3 P825 ALM 24/125V RLY2 PCB ASSY
P825-SPR-005	SmartAlarm Active Alarm card Spares MLPCBP82522-33 P825 ALM 24/125V RLY2 PCB ASSY - CC
P825-SPR-006	SmartAlarm Active Alarm card Spares MLPCBP82523-3 P825 ALM 48/250V PCB ASSY
P825-SPR-007	SmartAlarm Active Alarm card Spares MLPCBP82523-33 P825 ALM 48/250V PCB ASSY - CC
P825-SPR-008	SmartAlarm Active Alarm card Spares MLPCBP82524-3 P825 ALM 48/250V RLY2 PCB ASSY
P825-SPR-009	SmartAlarm Active Alarm card Spares MLPCBP82524-33 P825 ALM 48/250V RLY2 PCB ASSY - CC
P825-SPR-010	SmartAlarm Active Alarm card Spares MLPCBP82525-3 P825 ALM 24/125V RLY1 PCB ASSY
P825-SPR-011	SmartAlarm Active Alarm card Spares MLPCBP82526-3 P825 ALM 48/250V RLY1 PCB ASSY

Common Card Spares

Product Code	Description
P825-SPR-012	SmartAlarm Common Services card Spares MLPCBP82531-3 P825 COMMON SERVICES PCB ASSY
P825-SPR-013	SmartAlarm Common Services card Spares MLPCBP82531-33 P825 COMMON SERVICES PCB ASSY - CC

Power Supply Spares

Product Code	Description
P825-SPR-014	SmartAlarm Power Supply card Spares MLPCBP82541-3 P825 P1-AC P2-AC PCB ASSY
P825-SPR-015	SmartAlarm Power Supply card Spares MLPCBP82541-33 P825 P1-AC P2-AC PCB ASSY - CC
P825-SPR-016	SmartAlarm Power Supply card Spares MLPCBP82547-3 P825 P1-AC P2-NONE PCB ASSY
P825-SPR-017	SmartAlarm Power Supply card Spares MLPCBP82547-33 P825 P1-AC P2-NONE PCB ASSY - CC
P825-SPR-018	SmartAlarm Power Supply card Spares MLPCBP82550-3 P825 P1-36V P2-NONE PCB ASSY
P825-SPR-019	SmartAlarm Power Supply card Spares MLPCBP82550-33 P825 P1-36V P2-NONE PCB ASSY - CC
P825-SPR-020	SmartAlarm Power Supply card Spares MLPCBP82551-3 P825 P1-AC P2-36V PCB ASSY
P825-SPR-021	SmartAlarm Power Supply card Spares MLPCBP82551-33 P825 P1-AC P2-36V PCB ASSY - CC
P825-SPR-022	SmartAlarm Power Supply card Spares MLPCBP82552-3 P825 P1-36V P2-36V PCB ASSY
P825-SPR-023	SmartAlarm Power Supply card Spares MLPCBP82552-33 P825 P1-36V P2-36V PCB ASSY - CC

LED Spares

Product Code	Description
P825-SPR-024	P825LED-SMT-BL SmartAlarm P825 BLUE LED
P825-SPR-025	P825LED-SMT-GN SmartAlarm P825 GREEN LED
P825-SPR-026	P825LED-SMT-RD SmartAlarm P825 RED LED
P825-SPR-027	P825LED-SMT-WT SmartAlarm P825 WHITE LED
P825-SPR-028	P825LED-SMT-YW SmartAlarm P825 YELLOW LED

22 SERVICING

Module Removal

All of the cards within the SmartAlarm are removable from the front of the instrument

To remove a card we recommend the following procedure:-

1. Isolate the power to the Annunciator.
2. Undo the retaining screws on the face of the annunciator and remove the face plate.
3. Remove the Alarm or Common Services card as required.
4. Alarm cards and Common Services cards are keyed to prevent accidental insertion into the incorrect slot.

IMPORTANT

Although alarm cards are universal in type, if a card has been replaced the user will need to download the original software configuration to the unit to ensure that the features of the new card match the original one.

 WARNING	<p style="text-align: center;">WARNING !</p> <p style="text-align: center;">Installation, configuration and maintenance of this annunciator must only be performed by competent service personnel</p>
--	--

 WARNING	<p style="text-align: center;">WARNING !</p> <p style="text-align: center;">For hazardous voltage above 60Vdc (SELV) please isolate the supply before carrying out any work</p>
--	--

23 CONTACT

Eaton Electric Limited
Great Marlings
Butterfield
Luton
Bedfordshire
LU2 8DL

Telephone / Fax Number List

Telephone: 0044 (0) 1582 723633

Fax: 0044 (0) 1582 422283

Email address: RTKENquiry@Eaton.com

Procedures for Factory Repair and Return Warranty.

All products are tracked through a quality maintenance system located at our Luton based manufacturing site. Any warranty or repairs are managed by supplying the customer with a unique QN number that tracked any return through the system.

For assistance with any warranty claim or repair, please contact our repair team s on the above number who will then guide you through the process