

Multi-Sense™ Series - Model 260

Very Low Differential Multi-Configurable Pressure Transducer

Unidirectional Ranges: 0.1 - 10 in. W.C. to .25 - 2.5 kPa FS
 Bidirectional Ranges: ± 0.1 - 10 in. W.C. to ± 0.25 - 2.5 kPa FS

Air or Non-Conducting Gas



Setra Systems 260 pressure transducers sense differential or gauge (static) pressure and convert this pressure difference to a proportional electrical output for either field selectable unidirectional or bidirectional pressure ranges. The 260 Series is offered with field selectable high level analog outputs of 0 to 5, and 0 to 10 VDC, or 4 to 20 mA.

Used in Building Energy Management Systems, these transducers are capable of measuring pressures and flows with the performance necessary for proper building pressurization and air flow control.

The 260 Series transducers can be configured for air pressure ranges as low as 0.1 in. W.C. full scale, with pascal ranges as low as 25 Pa full scale. Static standard accuracy is $\pm 1.0\%$ full scale in normal ambient temperature environ-

ments. The units are temperature compensated to within $\pm 0.03\%FS/^\circ F$ ($0.054\%FS/^\circ C$) for zero and span.

The Model 260 utilizes an all stainless steel micro-tig welded sensor. The tensioned stainless steel diaphragm and insulated stainless steel electrode, positioned close to the diaphragm, form a variable capacitor. Positive pressure moves the diaphragm toward the electrode, increasing the capacitance. A decrease in pressure moves the diaphragm away from the electrode, decreasing the capacitance. The change in capacitance is detected and converted to a linear DC electrical signal by Setra's custom ASIC technology.

Optional Static Probe Designed with a Gasket to Seal Against the Duct.

U.S. Patent nos. 4093915; 4358814; 4434203; 6019002; 6014800.
 Other Patents Pending.

Ranges

Model	Unidirectional	Bidirectional
MS1	0.1, 0.25, 0.5, 1.0 in. WC FS	$\pm 0.1, 0.25, 0.5, 1.0$ in. WC FS
MS2	1.0, 2.5, 5.0, 10 in. WC FS	$\pm 1.0, 2.5, 5.0, 10$ in. WC FS
MS3	25, 50, 100, 250 Pa FS	$\pm 25, 50, 100, 250$ Pa FS
MS4	.25, .50, 1.00, 2.5 kPa FS	$\pm .25, .50, 1.00, 2.5$ kPa FS

Target Users

- Service/Retrofit Friendly
- Small Users - Inventory & Installation Savings
- Sub-Contractors - Quick Installation
- Flexible for Building Specification Changes
- Service Technicians - Quick and Accurate Reconfigurations

Features

- Optional 4 Digit LCD
- Field Selectable Multi-Range
- Field Selectable Multi-Output
- Simple 5-Step Setup
- Field Accessible Push Button Zero and Span
- Hinged Cover
- External Mounting Tabs
- Unregulated AC/DC Operation
- Microprocessor Based Electronics - Guarantees Range to Range Performance
- NIST Traceable
- Fire Retardant Case (UL 94 V-0 Approved)
- Meets CE Conformance Standards
- Fully RoHS Compliant



Visit Setra Online:
<http://www.setra.com>

setra
 800-257-3872

Model 260 Specifications

Performance Data

Thru All Field Selectable Ranges

	Standard
Accuracy* RSS (at constant temp)	±1.0% FS
Non-Linearity, BFSL	±0.96% FS
Hysteresis	0.10% FS
Non-Repeatability	0.05% FS

Thermal Effects**

Compensated Range °F (°C)	32 to 122°F (0 to 50°C)
Zero/Span Shift %FS/°F(°C)	0.03 (0.054)
Maximum Line Pressure	10 PSI
Overpressure	UP To 10 PSI (Range Dependent)
Long Term Stability (max)	2.0% FS/YR

Position Effect

Zero Offset (%FS/G) 0.2%

(Unit is factory calibrated at 0g effect in the vertical position.)

* RSS of Non-Linearity, Hysteresis, and Non-Repeatability.

**Units calibrated at nominal 70°F. Maximum thermal error computed from this datum.

NOTE: Setra quality standards are based on ANSI-Z540-1.

The calibration of this product is NIST traceable.

Environmental Data

Temperature	
Operating* °F (°C)	32 to 122°F (0 to 50°C)

Physical Description

Case	Fire-Retardant Glass Filled Polyester (UL 94 V-0 Approved)
	Hinged Lid
Mounting	Two External Screw Holes
	Vertical Position
Electrical Connection	Removable Screw Terminal Block
Pressure Fittings	3/16" O.D. Barbed Brass
	Pressure Fitting
Zero	Push Button
Span	Push Button
Weight (approx.)	8 Ounces

Pressure Media

Typically air or similar non-conducting gases.

Electrical Data (Voltage)

Circuit	3-Wire (Com, Exc, Out)
Excitation	13 - 30 VDC/18-24VAC
Field Selectable Output*	0 to 5 or 0 to 10 VDC**
Bidirectional Output at Zero	
Pressure	0 to 5 VDC = 2.5 VDC 0 to 10 VDC = 5 VDC
Output Impedance	300 ohms
*Calibrated into a 50K ohm load, operable into a 10K ohm load or greater.	
**Span (Full Scale) output factory set to within 1%.	

Electrical Data (Current)

Circuit	2-Wire
	Reverse Wiring Protected
Excitation	24V (DC Only)
Field Selectable Output*	4 to 20mA**
Bidirectional Output at Zero	
Pressure:	12mA**
External Load	0 to 800 ohms
Minimum supply voltage (VDC) =	13 Volts (at terminal)
Maximum supply voltage (VDC) =	30 Volts (at terminal)
*Calibrated at factory with a 24 VDC loop supply voltage and a 250 ohm load.	
**Span (Full Scale) output factory set to within ±0.16mA.	

Specifications subject to change without notice.

Outline Drawings

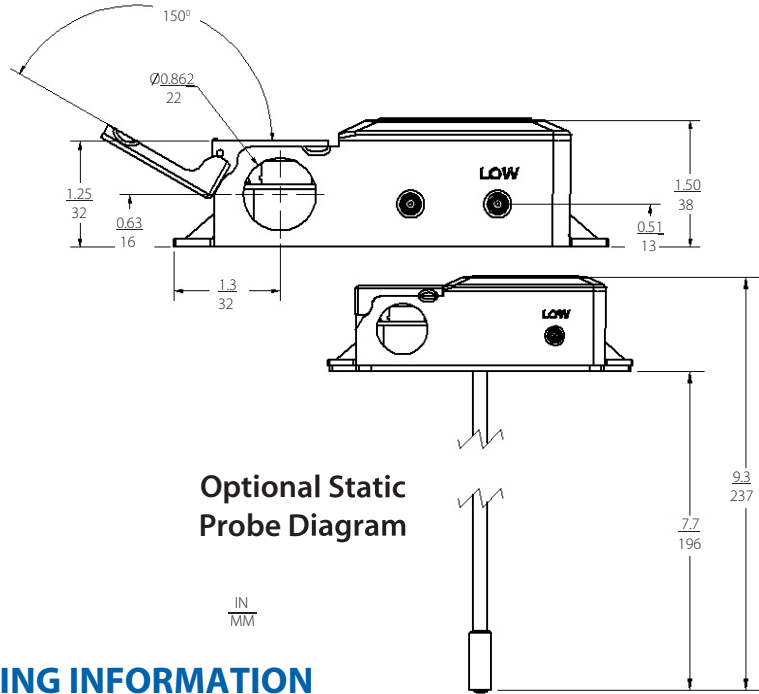
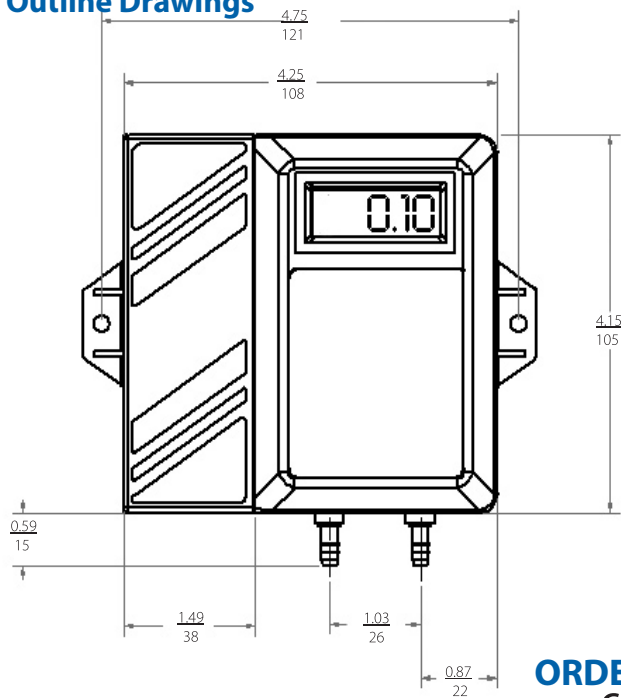

Optional Static Probe Diagram

IN
MM

SS260 Rev. C 01/13/09

ORDERING INFORMATION

Code all blocks in table.

Example: Part No. 2601MS1S for a 260 Transducer 0 to 1.0 in. WC Range..., with Static Pressure Probe

2	6	0	1	—		—	
Model 2601 = 260					Ranges		Options
					Unidirectional/Bidirectional		
				MS1	= 0.1, 0.25, 0.5, 1.0 in. WC FS/ ±0.1, 0.25, 0.5, 1.0 in. WC FS	S = Static Pressure Probe	
				MS2	= 1.0, 2.5, 5.0, 10 in. WC FS/ ±1.0, 2.5, 5.0, 10 in. WC FS	N = No Display	
				MS3	= 25, 50, 100, 250 Pa FS/ ±25, 50, 100, 250 Pa FS	Z = Static Pressure Probe/No Display	
				MS4	= .25, .50, 1.00, 2.5 kPa FS/ ±.25, .50, 1.00, 2.5 kPa FS		
Please contact factory for versions not shown.							