

# Model 231RS Multi-Sense® Wet-to-Wet Pressure Transducer with Remote Sensors

## Installation and Operating Instructions



CE  
RoHS

**setra**

978-263-1400; 800-257-3872  
[www.setra.com](http://www.setra.com); [sales@setra.com](mailto:sales@setra.com)

# Contents

1.0 GENERAL INFORMATION.....	3
2.0 MECHANICAL INSTALLATION .....	3
2.1 Media compatibility .....	3
2.2 Environment .....	3
2.3 Pressure Fittings .....	4
2.4 Mounting .....	4
2.5 Installation Procedures .....	4
3.0 ELECTRICAL INSTALLATION .....	7
3.1 Electrical Termination	
Wiring: 2-Wire , 4 to 20 mA and Remote Zero .....	7
3.2 Electrical Termination	
Wiring: 3-Wire, 0 to 5, 0 to 10, 1-5 VDC and Remote Zero .....	8
3.3 Remote Sensors Installation.....	9
4.0 CONFIGURATION .....	11
5.0 RETURNING PRODUCTS FOR REPAIR .....	12
6.0 WARRANTY AND LIMITATION OF LIABILITY .....	12

# Model 231RS Remote Sensors

## Installation and Operating Instructions

### Multi-Sense® Model 231RS Series

#### Wet-to-Wet Differential Pressure Transducers

Your 231RS w/Conduit or 231RS w/Cable is shipped with the following:

Conduit Version (231GRSX3MX)		Cable Version (231GRSX4MXXX)	
Item	Qty	Item	Qty
Housing	1	Housing	1
Pressure Transducers	2	Pressure Transducers	2
User Manual	1	Cable Assemblies	2
		User Manual	1

## 1.0 GENERAL INFORMATION

Every Model 231RS has been calibrated and tested before shipment to guarantee performance of all pressure ranges.

The Model 231RS has field selectable unidirectional and bidirectional pressure ranges, configurable 0 to 5 VDC, 0 to 10 VDC, and 1 to 5 VDC output, true two-wire 4 to 20 mA output, and auto-zero capability. Each unit is factory calibrated to the highest pressure range. The range label on the side of the units indicates the factory calibrated range. **(Reminder: Your application's highest line pressure should be  $\leq$  to the highest pressure range of the 231RS range code you selected when you purchased the 231RS, see Range Codes in table below, [range codes also listed inside housing cover].)**

Model 231RS pressure transducers sense wet-to-wet differential pressure and convert this difference in pressure to a proportional high level analog output.

Your Multi-Sense® Model 231RS pressure transducer has been ordered in one of the following versions:

### Range Code Unidirectional

RS1	5, 10, 25, 50 psid
RS2	7.5, 15, 37.5, 75 psid
RS3	10, 20, 50, 100 psid
RS4	15, 30, 75, 150 psid
RS5	25, 50, 125, 250 psid

### Bidirectional

$\pm 5, \pm 10, \pm 25, \pm 50$ psid
$\pm 7.5, \pm 15, \pm 37.5, \pm 75$ psid
$\pm 10, \pm 20, \pm 50, \pm 100$ psid
$\pm 15, \pm 30, \pm 75, \pm 150$ psid
$\pm 25, \pm 50, \pm 125, \pm 250$ psid

## 2.0 MECHANICAL INSTALLATION

### 2.1 Media Compatibility

Model 231RS transducers are designed to be used with any gas or liquid compatible with 17-4 PH stainless steel. Never totally submerge the unit in any liquid.

### 2.2 Environment

The operating temperature limits of the Model 231RS are as follows:

Compensated Temperature Range °F (°C)	+32 to +130 (0 to +54)
Operating Temperature Range °F (°C)	-4 to +185 (-20 to +85)
Storage Temperature Range °F (°C)	-4 to +185 (-20 to +85)

### 2.3 Pressure Fittings

Standard pipe fittings and installation procedures should be used.

Model 231RS have 1/4" -18 NPT male fittings. The high pressure port and low pressure connections are located on the bottom of the unit, labeled "HI(+)" and "LO(-)" respectively.

#### Important:

Each remote sensor is labeled "HIGH PRESSURE SENSOR" or "LOW PRESSURE SENSOR". Match up the high pressure sensor to the high pressure electrical terminals, and the low pressure sensor to the low pressure electrical terminals. Otherwise, the performance may not meet the product linearity specifications.

#### Moisture Precautions

The Model 231RS is provided with a 0.875" DIA. conduit opening for electrical termination, intended for a 1/2" I.D. conduit connection. This opening must be sealed according to standard industry practices in order to prevent moisture ingress into the Model 231RS.

### 2.4 Mounting

The Model 231RS can be easily mounted using the two mounting tabs located on the side of the unit.

### 2.5 Installation Procedures

For differential pressure measurements, it is recommended that the pressure sensor be installed with a valve in each line.

**Important:** The maximum line pressure cannot exceed the maximum differential pressure of the sensor.

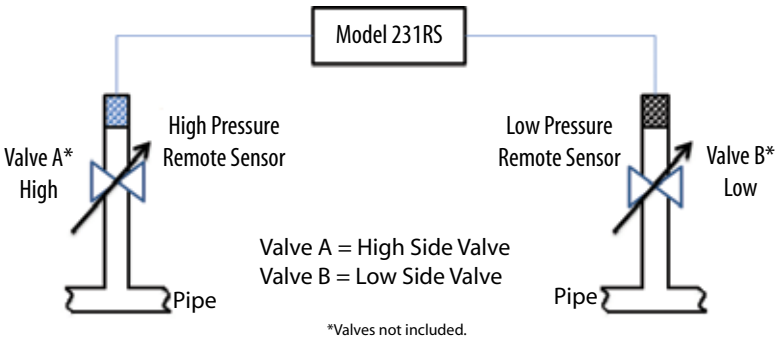
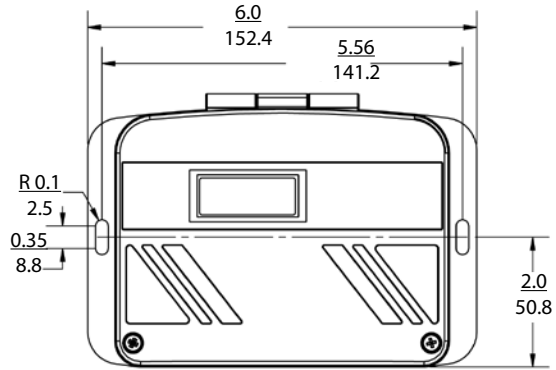
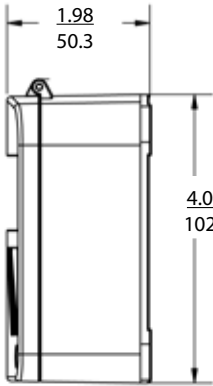

Figure 1

# Model 231RS (Conduit version, P/N: 231GRSX3MXXX) - Outline Drawing.



Front View



Side View

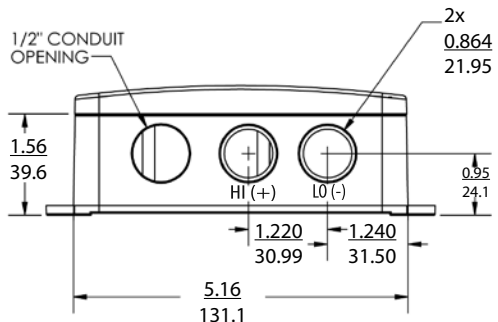

Bottom View

Figure 2

in.  
mm

# Model 231RS (Cable version, P/N: 231GRSX4MXXX) - Outline Drawing

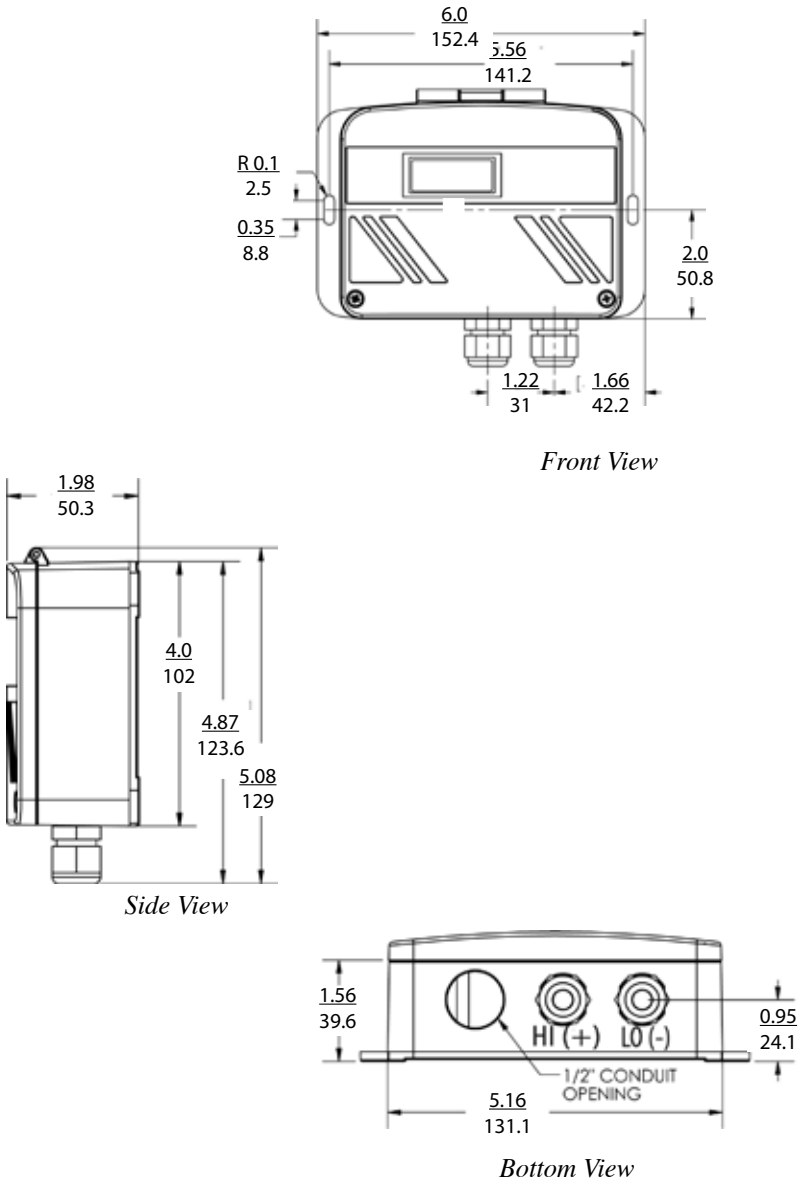

Figure 3

in.  
mm

### 3.0 ELECTRICAL INSTALLATION

To access the electrical connections, turn the screws on the top of the case counter clockwise until the hinged cover can be flipped up. The screws are captured and secured in the cover. Wiring is through the 1/2" conduit openings or PG fittings in the case of remote sensors with cable option. Both current and voltage outputs are reverse wiring protected.

*Note: The Zero terminals, connected to digital output, provide a contact closure relay for automatic reset to zero pressure by the monitoring system. CAUTION: ZERO input is for dry contact, do no apply voltage to ZERO Terminals*

#### 3.1 Electrical Termination

##### Wiring: 2-Wire, 4 to 20 mA and Remote Zero

Model 231RS when configured as a current output transducer is a true 2-wire, 4-20 mA current output device and delivers rated current into any external load of 0-250 ohms.

When configured as a 4-20 mA current output device the current flow is in one direction only. **PLEASE OBSERVE POLARITY.**

We suggest that an electrical cable shield be connected to the system's loop circuit ground to improve electrical noise isolation.

Min. Supply Voltage:  $15 + .02 \times (\text{Resistance of receiver plus line})$   
 Max. Supply Voltage:  $30 + .004 \times (\text{Resistance of receiver plus line})$

The optional remote zero is a normally open relay wired between COM and REMOTE ZERO terminals. In order to initiate ZERO function the relay contact should be closed and sensor must be vented to atmosphere.

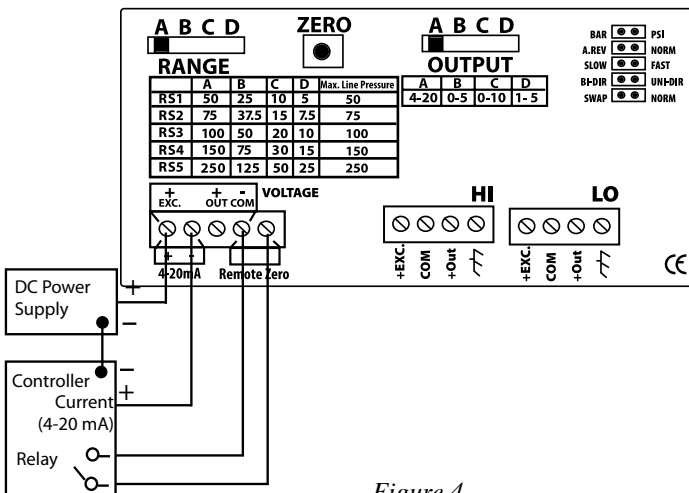

Figure 4

### 3.2 Electrical Termination

#### Wiring: 3-Wire, 0 to 5, 0 to 10, 1-5 VDC and Remote Zero

Model 231RS when configured for voltage output is a 3-wire circuit device with three terminals available for wiring.

Model 231RS can operate from 15-30 VDC (18-30 VAC) nominal output power supply.

*Note: The Zero terminals, connected to digital output, provide a contact closure relay for automatic reset to zero pressure by the monitoring system. **CAUTION: ZERO input is for dry contact, do not apply voltage to ZERO Terminals***

The optional remote zero is a normally open relay wired between COM and REMOTE ZERO terminals. In order to initiate ZERO function the relay contact should be closed and sensors must be vented to atmosphere.

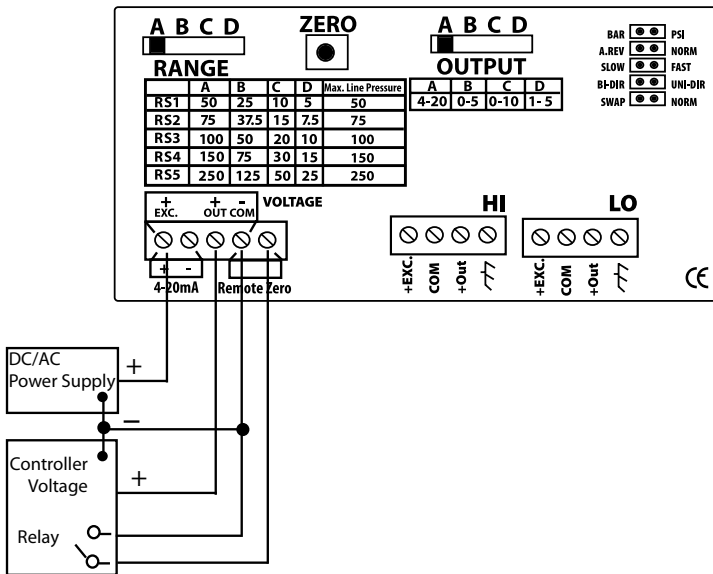
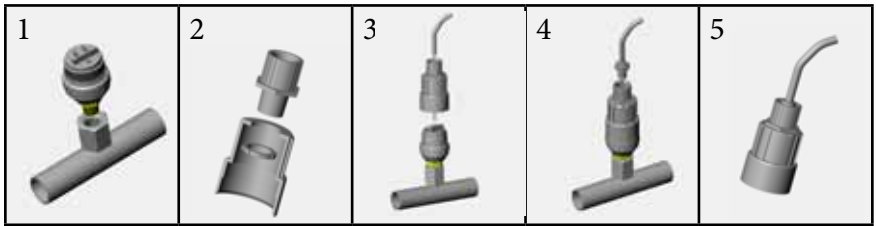

Figure 5



### 3.3 Remote Sensors Installation Conduit Version (P/N: 231GRSX4MX)

For conduit version remote sensors, use the following instructions:



1. Install the remote sensor into the system plumbing (use 3/4" hex to tighten).

**Important:**

Each remote sensor is labeled "HIGH PRESSURE SENSOR" OR "LOW PRESSURE SENSOR", respectively. Match up the high pressure sensor to the high "HI (+)" pressure electrical terminals, and the low "Lo (-)" pressure sensor to the low pressure electrical terminals. Otherwise, the performance may not meet the product linearity specifications.

2. Install a 1/2" conduit fitting into the remote sensor top cover and fasten the retaining nut.
3. Feed wires from a flexible conduit through the remote sensor top cover, fasten the wires to terminals.
4. Screw on the top cover.
5. Fit conduit into conduit fitting, and tighten conduit watertight strain relief.

To connect the wires from the remote sensor to the unit, remove the terminal blocks from the circuit board and use the following chart:  
Installation of the Model 231RS is now complete.

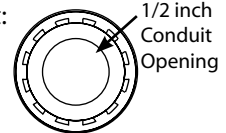
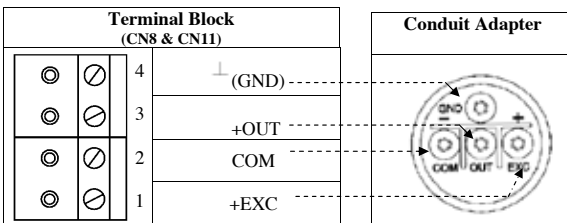

Chart 1. Electrical wiring chart for High & Low Pressure Sensors (Conduit version)

**CAUTION:**  
Reverse excitation will permanently damage unit. Please follow wiring instructions carefully.

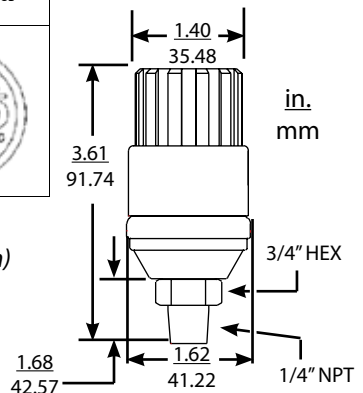

Figure 6  
Dimensional Drawing

**Cable Version (P/N: 231GRSX4MXXX)**

For conduit version remote sensors, use the following instructions:

1. Install the remote sensor into the system plumbing (use 3/4" hex to tighten).

**Important:**

Each remote sensor is labeled "HIGH PRESSURE SENSOR" OR "LOW PRESSURE SENSOR", respectively. Match up the high pressure sensor to the high pressure electrical terminals, and the low pressure sensor to the low pressure electrical terminals. Otherwise, the performance may not meet the product linearity specifications.

2. Attach the cable provided to the 3-Pin Packard connector on the remote sensor.
3. Feed the cable through the PG fitting on the bottom of the unit and tighten the fitting.
4. Remove the terminal blocks from the circuit board and use the following

Terminal Block (CN8 & CN11)			
⊙	⊗	4	⊥ (Shield)
⊙	⊗	3	+OUT (White) C
⊙	⊗	2	COM (Black) A
⊙	⊗	1	+EXC (Red) B

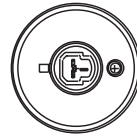
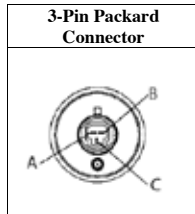

*Chart 2. Electrical wiring color chart for High & Low pressure sensors (Cable version)*

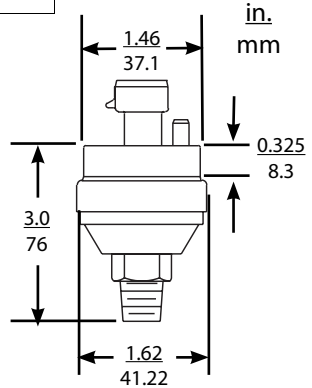

*Figure 7  
Dimensional Drawing*

**Important:** Prior to putting the unit into service, complete configuration setup in Section 4. After configuration is complete, press the "Zero" button.

Installation of the Model 231RS is now complete.

## 4.0 CONFIGURATION

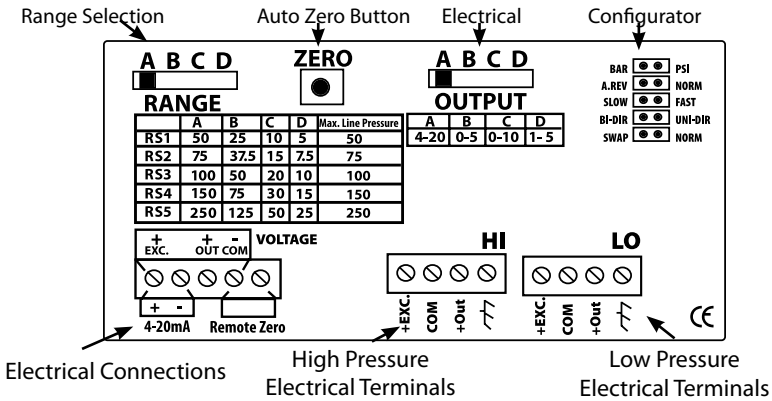

Figure 8

**Range Selection Switch:** The unit is set to the highest range when calibrated at the factory. To select the other ranges, slide the switch to the right. Important: **Push “zero” button after installing the Model 231RS, and after changing range.**

**Auto Zero Button:** Press and hold the “ZERO” push-button for 2 seconds to automatically reset zero or provide contact closure on “Remote Zero, see figure 4, pg. 7, and figure 5, pg. 8. Sensors must be vented to atmosphere.

**Electrical Output:** The unit is set at the factory to 4-20 mA. To select another output, move the slide switch to the right. Push the “Zero” button after changing the electrical output mode. Sensors must be vented to atmosphere.

**Electrical Connections:** Electrical termination for power supply, 3-wire voltage output and 2-wire true 4-20 mA current output, and remote zero wiring.

**BAR/PSI:** Jumper selectable engineering units in Bar ranges or PSI.

### A. REV/NORM:

**A.REV:** Analog Reverse: When in reverse mode, the output increases when the differential pressure decreases and decreases as pressure increases.

**NORM:** When in Normal mode output increases as pressure increases and decreases as pressure decreases.

**SLOW/FAST:** When Slow mode is selected, 5-second averaging is provided for surge damping.

**BI-DIR/UNI-DIR:** Select UNI-Directional or BI-Directional mode.

Unidirectional mode measures from 0 to full scale differential pressure.

Bidirectional mode measures pressure from minus 1/2 of full scale to plus 1/2 of full scale differential pressure. Output will read 1/2 full scale when differential pressure is zero.

**SWAP/NORM:** Jumper selectable Port Swap feature eliminates costly re-plumbing when incorrectly installed or replaced. Go from NORMAL to SWAP and the jumper makes the “HI” Port “LO” and the “LO” port “HI”.

**High Pressure Electrical Terminals (HI):** High pressure sensor termination.

**Low Pressure Electrical Terminals (LO):** Low pressure sensor termination.

## 5.0 RETURNING PRODUCTS FOR REPAIR

Please contact a Setra application engineer (800-257-3872, 978-263-1400) before returning unit for repair to review information relative to your application. Many times only minor field adjustments may be necessary. When returning a product to Setra, the material should be carefully packaged, and shipped to :

Setra Systems, Inc.  
159 Swanson Road  
Boxborough, MA 01719-1304  
Attn: Repair Department

To assure prompt handling, returned unit(s) must be accompanied by Setra's Return Order Form, completely filled out, found on Setra's web site at :

**[http://www.setra.com/contactus/contact\\_us\\_service\\_calibration.htm](http://www.setra.com/contactus/contact_us_service_calibration.htm)**

Notes: Please remove any pressure fittings and plumbing that you have installed and enclose any required mating electrical connectors and wiring diagrams.

Allow approximately 3 weeks after receipt at Setra for the repair and return of the unit. Non-warranty repairs will not be made without customer approval and a purchase order to cover repair charges.

### Calibration Services

Setra maintains a complete calibration facility that is traceable to the National Institute of Standards & Technology (NIST). If you would like to recalibrate or recertify your Setra pressure transducers or transmitters, please call our Repair Department at 800-257-3872 (978-263-1400) for scheduling.

## 6.0 WARRANTY AND LIMITATION OF LIABILITY

SETRA warrants its products to be free from defects in materials and workmanship, subject to the following terms and conditions: Without charge, SETRA will repair or replace products found to be defective in materials or workmanship within the warranty period; provided that:

- a) the product has not been subjected to abuse, neglect, accident, incorrect wiring not our own, improper installation or servicing, or use in violation of instructions furnished by SETRA;
- b) the product has not been repaired or altered by anyone except SETRA or its authorized service agencies;
- c) the serial number or date code has not been removed, defaced, or otherwise changed; and
- d) examination discloses, in the judgment of SETRA, the defect in materials or workmanship developed under normal installation, use and service;
- e) SETRA is notified in advance of and the product is returned to SETRA transportation prepaid.

Unless otherwise specified in a manual or warranty card, or agreed to in writing and signed by a SETRA officer, SETRA pressure and acceleration products shall be warranted for one year from date of sale.

The foregoing warranty is in lieu of all warranties, express, implied or statutory, including but not limited to, any implied warranty of merchantability for a particular purpose.

SETRA's liability for breach of warranty is limited to repair or replacement, or if the goods cannot be repaired or replaced, to a refund of the purchase price. SETRA's liability for all other breaches is limited to a refund of the purchase price. In no instance shall SETRA be liable for incidental or consequential damages arising from a breach of warranty, or from the use or installation of its products.

No representative or person is authorized to give any warranty other than as set out above or to assume for SETRA any other liability in connection with the sale of its products.

For all CE technical questions, contact Setra Systems, USA. EU customers may contact our EU representative, Hengstler GmbH, Uhlstrandstr 49, Germany (Tel: +49-7424-890; Fax: +40-7424-89500).

159, Swanson Road, Boxborough, MA 01719  
978-263-1400; 800-257-3872/www.setra.com; sales@setra.com

The logo for Setra, featuring the word "setra" in a bold, lowercase, sans-serif font. The letters are filled with a horizontal line pattern.