

Multi-Sense® Model 231

Wet-to-Wet, Differential, Multi-Configurable Pressure Transducer



NOTE: Setra quality standards are based on ANSI-Z540-1. The calibration of this product is NIST traceable. U.S. Patent nos. 6019002; 6014800

DESCRIPTION

Setra's Model 231 Multi-Sense Wet-to-Wet differential pressure transducer all-inclusive design provides users with field accessible ranging, choice of output and field zeroing.

Choose from three configurable Model 231 pressure transducers: 5 up to 50 psid, 10 up to 100 psid, or 25 up to 250 psid. Each Model 231 has 4 unidirectional and 4 bidirectional switch selectable pressure ranges and can be reconfigured in the field for 0-5 VDC, 1-5 VDC, -0-10 VDC, or 4 to 20 mA output. The Model 231 jumper selectable port swap feature eliminates costly replumbing if the pressure transducer is improperly installed or replaced. An optional LCD display is available for on-site indication of line and differential pressure.

FEATURES

- Field Selectable Output - True 4 to 20 mA, 0 to 5, 1 to 5, and 0 to 10 VDC
- Field Selectable Pressure Ranges
- Field Accessible Push-Button Zero and Remote Zero
- Dual Sensors
- Optional 3- or 5-Valve Manifold
- Hinged Cover
- Field Selectable Port Swap
- Optional LCD Display
- All Cast Aluminum, NEMA4 Rated Housing
- CE and RoHS Compliant

APPLICATIONS

- Energy Management Systems
- Process Control Systems
- Flow Measurement of Various Gases or Liquids
- Liquid Level Measurement of Pressurized Vessels
- Pressure Drop Across Filters

SPECIFICATIONS

Performance Data

Accuracy RSS¹ (at constant temp.)

Pressure Ranges A, B, C	±1.0% FS
Pressure Range D	±2.0% FS

Line Pressure Determines Selection of Range Code

Pressure Ranges

	A	B	C	D	Max. Line Pressure
MS1	50	25	10	5	50
MS2	100	50	20	10	100
MS3	250	125	50	25	250

Thermal Effects²

Compensated Range °F (°C)	+32 to +130 (0 to +54)
Zero Shift %FS/100°F (50°C)	2.0 (1.8)
Span Shift %FS/100°F (50°C)	2.0 (1.8)
Warm-up Shift	<0.12% FS
Response Time	1 to 5 sec. (selectable)
Proof Pressure	2 x Full Scale
Burst Pressure	15 x Full Scale (50 psi) 10 X Full Scale (75 x 150 psi) 8 x Full Scale (250 psi)

Environmental Data

Temperature	
Operating ³ °F (°C)	-4 to +185 (-20 to +85)
Storage °F (°C)	-4 to +185 (-20 to +85)
Vibration	10g from 50 Hz to 2000 Hz
Shock	200g

Physical Description

Case	Die Cast Aluminum, Powder Coated
Pressure Fittings	1/8-18 NPT Internal
Electrical Connection	1/2 in. Conduit
Size	4.0 x 6 x 2 in. (102 x 152 x 51mm)
Weight	1.5 lb
Sensor Cavity Volume	0.2 cc

Pressure Media

Liquids or Gases Compatible with 17-4 PH Stainless Steel
Note: Hydrogen not recommended for use with 17-4 PH stainless steel.

Electrical Data (Voltage)

Circuit	3-Wire
Excitation	15 to 30 VDC/18 to 30 VAC (Reverse Excitation Protected)
Output ⁴	0 to 5 VDC 0 to 10 VDC 1 to 5 VDC
Output Impedance	30 Ohms
Current Consumption	8 mA (typ.) at 5 VDC 8 mA (typ.) at 10 VDC 40 mA (typ.) at 18-30 VAC

Electrical Data (Current)

Circuit	2-Wire (Reverse Excitation Protected)
Output ⁵	4 to 20 mA
External Load	0 to 250 Ohms
Minimum supply voltage (VDC) =	15 + 0.02 x (Resistance of receiver plus line).
Maximum supply voltage (VDC) =	30 + 0.004 x (Resistance of receiver plus line).

¹ RSS of Non-Linearity, Hysteresis, and Non-Repeatability.

² Units calibrated at nominal 70°F. Maximum thermal error computed from this datum.

³ Operating temperature limits of the electronics only. Pressure media temperatures may be considerably higher or lower.

⁴ Calibrated into a 50K ohm load, operable into a 5000 ohm load or greater.

⁵ Calibrated at factory with a 24 VDC loop supply voltage and a 250 ohm load.

Specifications subject to change without notice.

DIMENSIONS

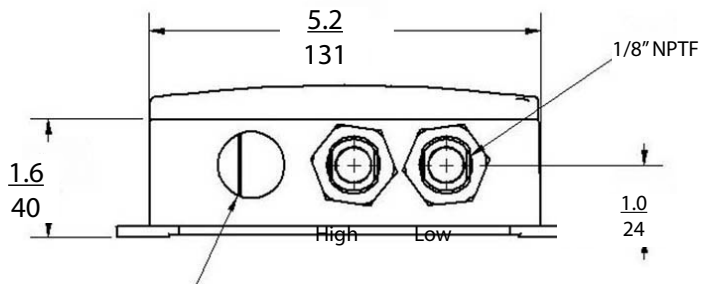
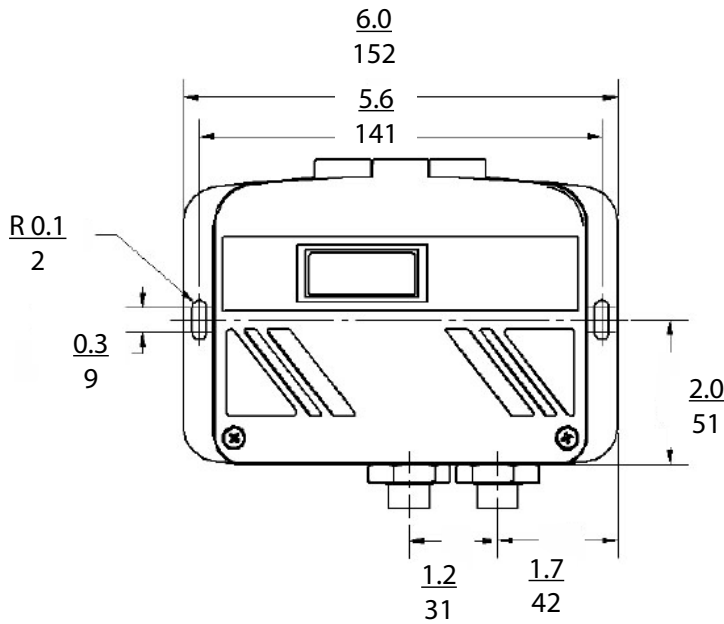

1/2" Conduit Opening

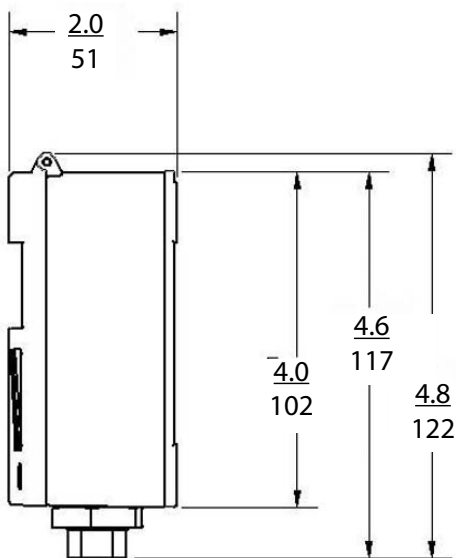

IN
MM

WIRING

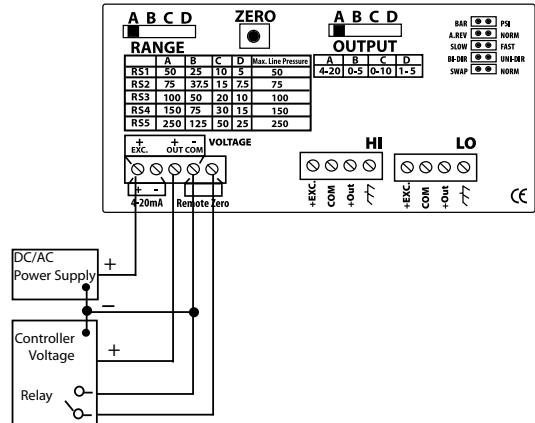

3-Wire - Voltage Output
 0 to 5 VDC
 0 to 10 VDC
 1 to 5 VDC
 Remote Zero

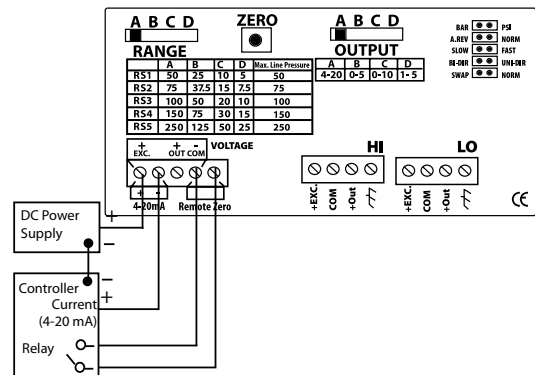

2-Wire - Current Output
 4 to 20 mA
 Remote Zero

SSP231RS RevA 09/14/11

Multi-Sense® Model 231

Wet-to-Wet, Differential, Multi-Configurable Pressure Transducer



DIMENSIONS (3-Valve Manifold Assembly)



3-Valve Manifold Assembly Description

(Order as Pressure Code Fitting "3V".)

Manifold Block	Brass
Valves (3)	V1 for connection to +port V2 for connection to -port V3 for equalizing pressure
Valve type	90 Degree On/Off
Process Connections	1/4"-18 NPT Internal Thread

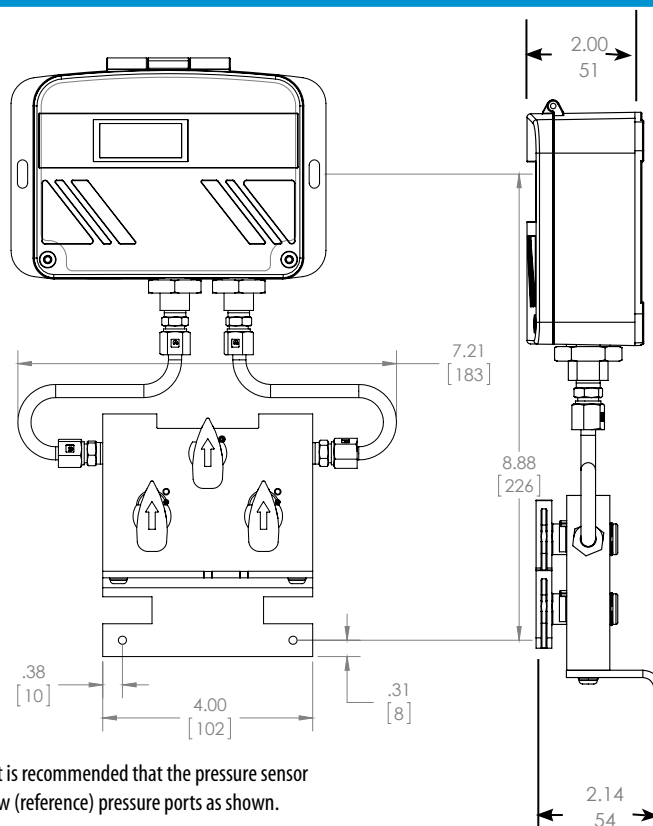
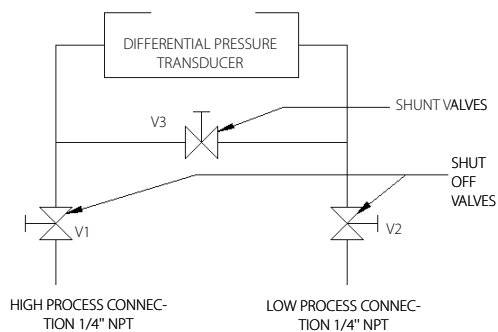

For differential pressure measurements at high line pressure (250 psig max), it is recommended that the pressure sensor be installed with a valve in each line, plus a shunt valve across the high and low (reference) pressure ports as shown.

DIMENSIONS (5-Valve Manifold Assembly)



5-Valve Manifold Assembly-Description

(Order as Pressure Code Fitting "5V".)

Manifold Block	Brass
Valves (5)	V1 for connection to ±port V2 for connection to -port V3 for equalizing pressure V4 for connection to external gauge or alternate plumbing configuration V5 for connection to external gauge or alternate plumbing configuration
Valve Type	90 Degree On/Off
Process Connection	1/4 "-18 NPT Internal Thread

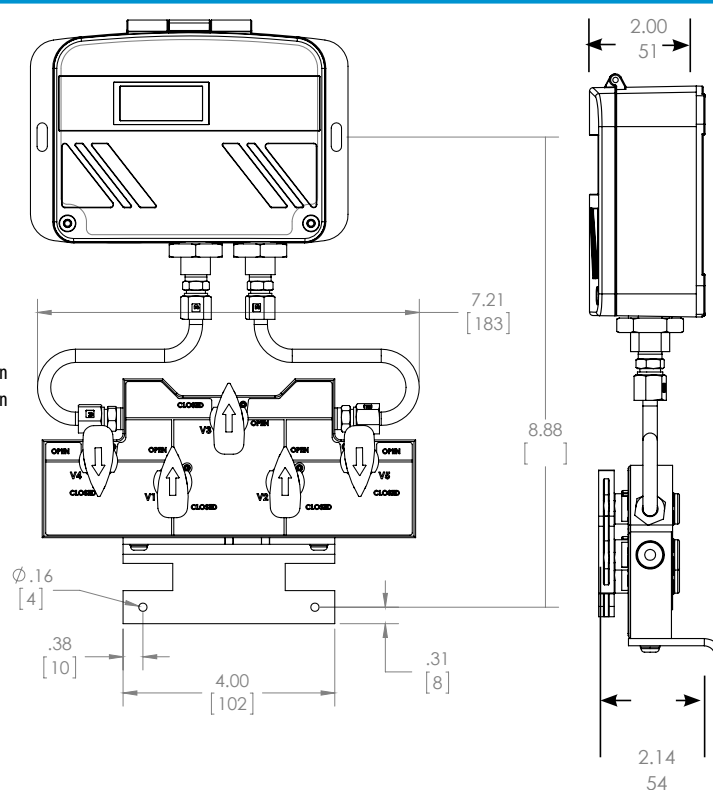
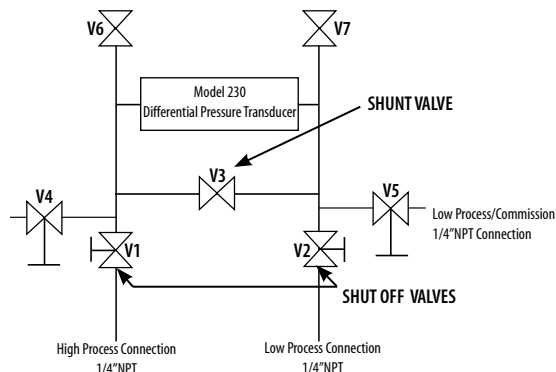

INSTALLATION

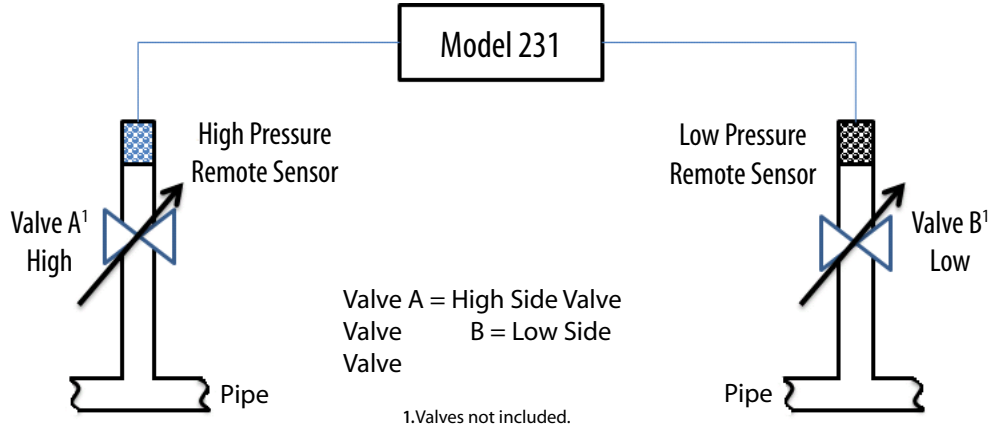

PRESSURE RANGE CODE SELECTOR (IMPORTANT: READ BEFORE ORDERING)

Line Pressure
Determines
Selection of Range
Code

Examine the pressure application and determine what is the Highest System Line Pressure.
Determine what is the Differential Pressure being measured.
Find the MAX. Line Pressure in the table on the right that is \geq to your Highest System Line Pressure.
Verify that your DP falls within the selectable ranges in that row.
Follow that row to the left and select that range code.

Range Code	A	B	C	D	Max. Line Pressure
RS1	50	25	10	5	50
RS2	75	37.5	15	7.5	75
RS3	100	50	20	10	100
RS4	150	75	30	15	150
RS5	250	125	50	25	250

Example: Highest System Line Pressure: 125 psig
 Differential Pressure Measured: 75 psid
 "Max Line Pressure" \geq to System Line Pressure: 150 psid (75 psid DP falls within ranges in this row)
 Select Range Code: RS4

ORDERING INFORMATION

2 3 1 G - - -

Model	Range Code	Pressure Connection			Display		
231 = 231G	See Table 1 Below	Std.	2F	1/8-18 NPT female (Standard) Sensor (Conduit Version)	Std.	N	No Display
		Opt.	3V	3-V Manifold assembled w/ Model 231	Opt.	D	LCD Display
		Opt.	5V	5-V Manifold assembled w/ Model 231			

Please contact factory for versions not shown.

Table 1. Range Specification*

RANGE CODE	UNIDIRECTIONAL PRESSURE RANGES	BIDIRECTIONAL PRESSURE RANGES
MS1	5, 10, 25, 50 psid	$\pm 5, \pm 10, \pm 25, \pm 50$ psid
MS2	10, 20, 50, 100 psid	$\pm 10, \pm 20, \pm 50, \pm 100$ psid
MS3	25, 50, 125, 250 psid	$\pm 25, \pm 50, \pm 125, \pm 250$ psid

*Note: Maximum line pressure is maximum range of pressure ordered.