

## Model LD 330 Local Display



Setra's Model LD 330 is a small Local Display designed to be easily installed in-line between a Setra pressure transducer and the user's data acquisition system and power supply. It has a low power consumption 3-1/2 digit analog to digital converter with a Liquid Crystal Display (LCD). The compact housing allows transducer and power supply connection through a variety of electrical terminations. The LD 330 is factory calibrated

to read the specified range in engineering units. Zero and Span display adjustments are made through multi-turn potentiometers conveniently located on the front face. The LD 330 is lightweight and easily mounted using back or bottom mount integral connectors. With the Bayonet or Mini-Din connector, the housing rotates up to 280 degrees for optimum display viewing.

### Specifications

	LD 330V Voltage Input Display	LD 330C Loop Powered Display
<b>Display</b>		
Digits	-999 to 1999	-999 to 1999
Type	7 Segment LCD, Green Backlit	7 Segment LCD (Backlit Optional)
Polarity	Automatic (-) Display	Automatic (-) Display
Overload	1 Followed by Blank Display	1 Followed by Blank Display
Accuracy	0.25% of Reading $\pm 1$ Count	0.25% of Reading $\pm 1$ Count
<b>Environmental</b>		
Operating Temperature	+32°F to +140°F (0°C to +60°C)	+32°F to +140°F (0°C to +60°C)
Storage Temperature	-40°F to +158°F (-20°C to +70°C)	-40°F to +158°F (-20°C to +70°C)
Temperature Coefficient	100 ppm/°C	100 ppm/°C
<b>Electrical Data</b>		
Input Signal	0.5 to 10.5 VDC Full Scale Voltage	4-20 mA Loop Powered
Excitation	8 VDC to 30 VDC (Display Only)	4 VDC Max Voltage Drop
	300k Ohm Minimum Input Impedance	
	30 mA Current Consumption	
	3 mA with Backlight Disabled	
	At 32 VDC = 15 mA	
Zero/Span Adjustment	Multi-Turn Potentiometers	Multi-Turn Potentiometers
Protection	Reverse Polarity Protection	100 mA Current Limit

NOTE: Setra adheres to strict quality standards including ISO 9001 and ANSI-Z540-1. The calibration of this product is NIST traceable.

### Applications

- Semiconductor Process Tools
- High Purity Gas Delivery Systems
- Integrated Gas Sticks

### Features

- Convenient Local Display
- Small Size
- Low Power Consumption
- 3-1/2 Digit LCD Display
- Designed to be Installed In-line
- Pressure Displayed in Desired Engineering Units
- Available for Voltage or Current Input Devices
- Easily Mounted with Integral Connectors
- Low Cost
- Available in Panel Mount Version
- Meets CE Conformance Standards

When it comes to a product to rely on, choose the Model LD 330. When it comes to a company to trust, choose Setra.



Visit Setra On-line:  
<http://www.setra.com>

**setra**  
800-257-3872

# Model LD 330 Specifications

## Outline Drawings

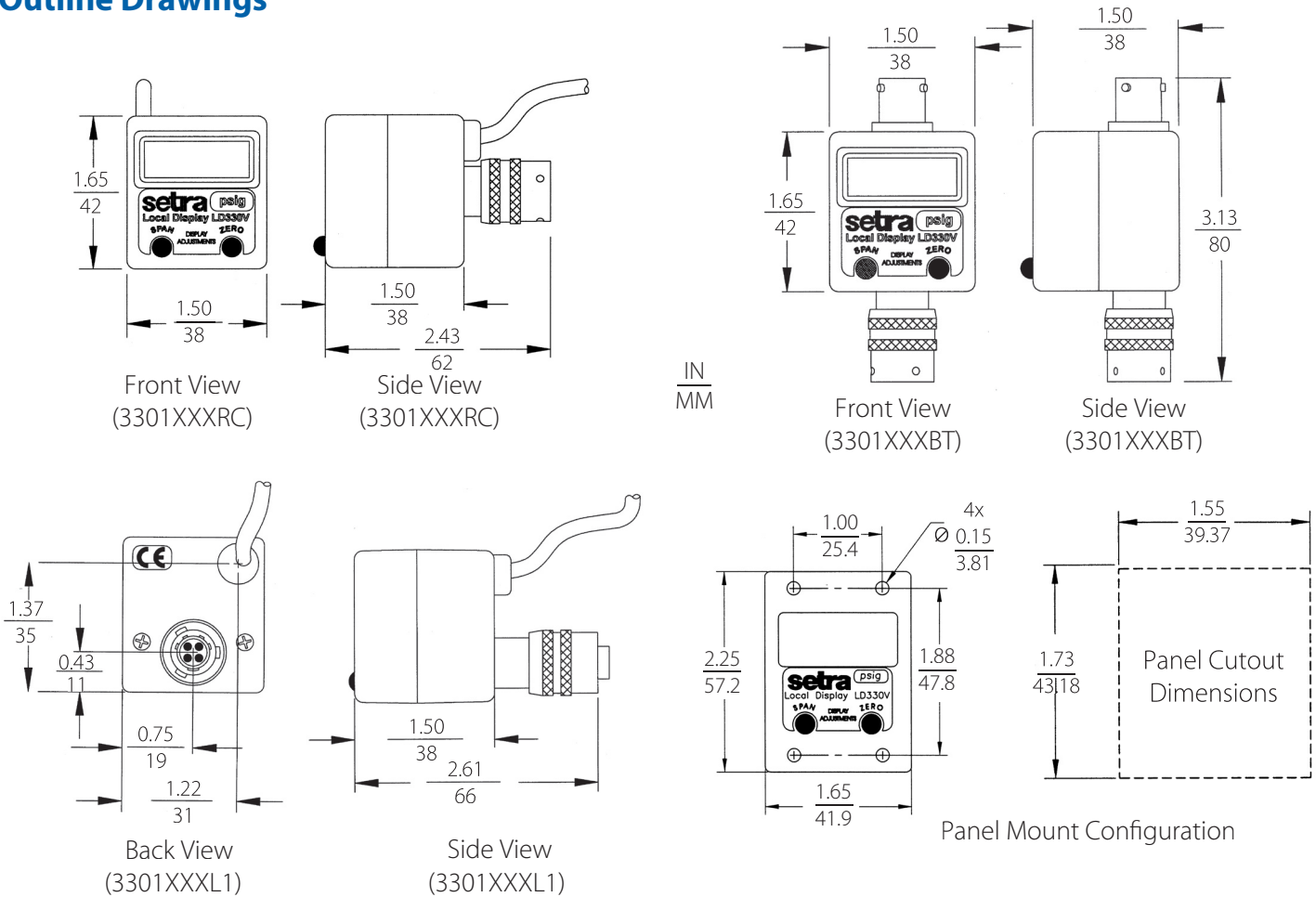

Typical configurations. Consult factory for other configuration dimensions.  
Specifications subject to change without notice.

## ORDER and SPECIFYING INFORMATION

Code all blocks in table.

Example: Part No. 3301-V-3-C-B-T is a Model 330 with 0.2 to 5.2 VDC input, 100.0 pressure range, compound pressure, Bayonet-Female-Bottom connection to transducer and a Bayonet-Male-Top connection to power supply.

3	3	0	1							
Model	Input	Pressure Range PSI Range	Pressure	Electrical Connection to Transducer	Electrical Connection to Power Supply	Options				
3301 = 330	V = 0.2-5.2 VDC M = 0-5 VDC N = 0.2-10.2 VDC L = 0-10 VDC C = 4-20 mA B = 4-20 mA Backlit	1 = 25.0 2 = 50.0 3 = 100.0 4 = 250 5 = 500 6 = 1000 7 = 3.00K psi  Bar Range A = 1.700 B = 3.40 C = 7.00 D = 17.00 E = 34.0 F = 70.0 G = 210 H = 200 J = 35.0	G = Gauge C = Compound A = Absolute	B = Bayonet, Female, Bottom R = Bayonet, Female, Rear L = Bayonet, Female, Low Rear H = Bayonet, Female, High Rear M = Mini-Din, Male, Rear N = Mini-Din, Male, Bottom D = High-Density 15 pin D-Sub, Female, Rear E = High-Density 9 Pin D-Sub, Female, Rear F = Molex, Male, Rear G = High-Density 9 Pin D-Sub, Female, Bottom	T = Bayonet, Male, Top R = Bayonet, Male, Rear A = AMD, Jack, Top C = 6ft. Cable, Rear K = 6ft. Cable, Top D = High Density 15 Pin D-Sub, Male, Bottom E = High Density 9 Pin D-Sub, Male, Bottom B = Bayonet, Male, Bottom F = 1 ft. Cable, Top J = 2 ft. Cable, Top L = 3 ft. Cable, Top U = 4 ft. Cable, Top V = 5 ft. Cable, Top W = 7 ft. Cable, Top 1 = 1 ft. Cable, Rear 2 = 2 ft. Cable, Rear 3 = 3 ft. Cable, Rear 4 = 4 ft. Cable, Rear 5 = 5 ft. Cable, Rear 7 = 7 ft. Cable, Rear	NONE = (leave blank) for Standard Display PN = Panel Mount (Panel Mount is not available for 4-20 mA Backlit, Code B)	Please contact factory for versions not shown.			

While we provide application assistance on all Setra products both personally and through our literature, it is the customer's responsibility to determine the suitability of the product in the application.

159 Swanson Road, Boxborough, MA 01719/Tel: 978-263-1400; Toll Free: 800-257-3872; Fax: 978-264-0292; email: sales@setra.com

