



Model 264

Very Low Differential Pressure Transducer

Unidirectional Ranges: 0 - 0.1 to 0 - 100 in. W.C.

Bidirectional Ranges: 0 - ±0.5 to 0 - ±50 in. W.C.

Air or Non-Conducting Gas

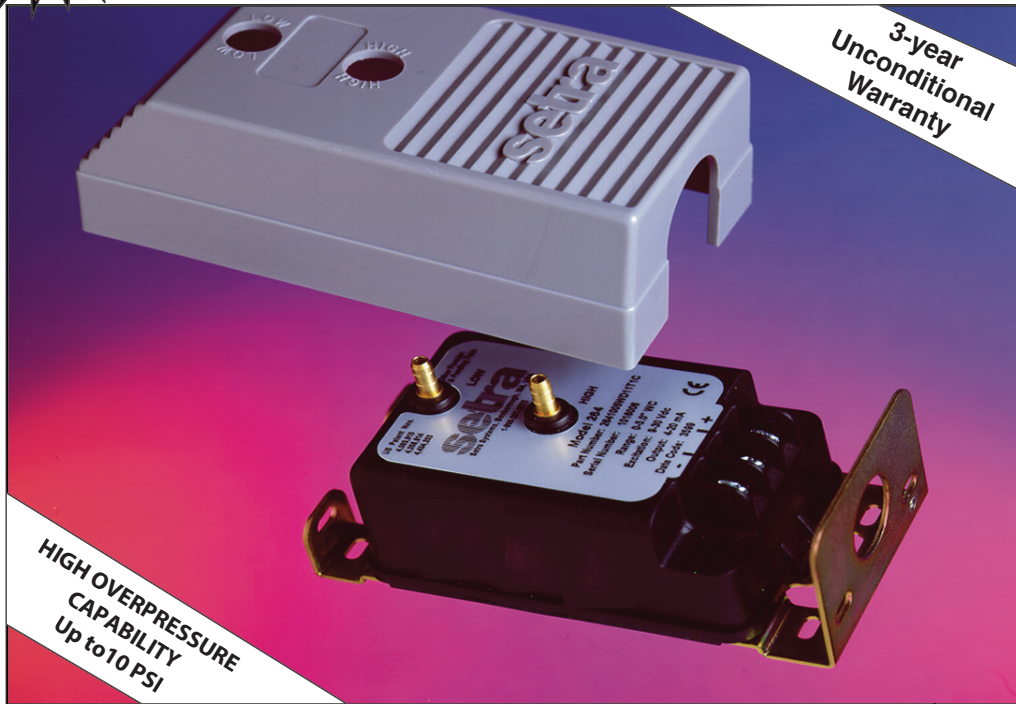

Applications

- Heating, Ventilating and Air Conditioning (HVAC)
- Energy Management Systems
- Variable Air Volume and Fan Control (VAV)
- Environmental Pollution Control
- Lab and Fume Hood Control
- Oven Pressurization and Furnace Draft Controls

Features

- Up to 10 PSI Overpressure (Range Dependent)
- Installation Time Minimized with Snap Track Mounting and Easy-To-Access Pressure Ports and Electrical Connections
- 0 to 5 VDC or 2-wire 4 to 20 mA Analog Outputs Are Compatible with Energy Management Systems
- Reverse Wiring Protection
- Internal Regulation Permits Use with Unregulated DC Power Supplies
- Fire Retardant Case (UL 94 V-0 Approved)
- Meets CE Conformance Standards

Setra Systems 264 pressure transducers sense differential or gauge (static) pressure and convert this pressure difference to a proportional electrical output for either unidirectional or bidirectional pressure ranges. The 264 Series is offered with a high level analog 0 to 5 VDC or 4 to 20 mA output.

Used in Building Energy Management Systems, these transducers are capable of measuring pressures and flows with the accuracy necessary for proper building pressurization and air flow control.

The 264 Series transducers are available for air pressure ranges as low as 0.1 in. W.C. full scale to 100 in. W.C. full scale. Static standard accuracy is ±1.0% full scale in normal ambient temperature environments, but higher accuracies are available. The units are temperature compensated to 0.033% FS/°F thermal error over the temperature range of 0°F to +150°F.

The Model 264 utilizes an improved all stainless steel micro-tig welded sensor. The tensioned stainless steel diaphragm and insulated stainless steel electrode, positioned close to the diaphragm, form a variable capacitor. Positive pressure moves the diaphragm toward the electrode, increasing the capacitance. A decrease in pressure moves the diaphragm away from the electrode, decreasing the capacitance. The change in capacitance is detected and converted to a linear DC electrical signal by Setra's unique electronic circuit.

The tensioned sensor allows up to 10 PSI overpressure (range dependent) with no damage to the unit. In addition, the parts that make up the sensor have thermally matched coefficients, which promote improved temperature performance and excellent long term stability.

When it comes to a product to rely on - choose the Model 264. When it comes to a company to trust - choose Setra.



Visit Setra Online:
<http://www.setra.com>

setra
800-257-3872

NOTE: Setra quality standards are based on ANSI-Z540-1. The calibration of this product is NIST traceable.

U.S. Patent nos. 4093915; 4358814; 4434203; 6019002; 6014800. Other Patents Pending.

Model 264 Specifications

Performance Data

	Standard	Optional
Accuracy* RSS(at constant temp)	±1.0% FS	±0.4% FS ±0.25% FS
Non-Linearity, BFSL	±0.96% FS	±0.38% FS ±0.22% FS
Hysteresis	0.10% FS	0.10% FS 0.10% FS
Non-Repeatability	0.05% FS	0.05% FS 0.05%FS

Thermal Effects**

Compensated Range °F(°C)	0 to +150 (-18 to +65)
Zero/Span Shift %FS/°F(°C)	0.033 (0.06)
Maximum Line Pressure	10 psi
Overpressure	Up to 10 psi (Range Dependent)
Long Term Stability	0.5% FS/1 YR

Position Effect	Range	Zero Offset (%FS/G)
(Unit is factory calibrated at 0g effect in the vertical position.)	To 0.5 in. WC	0.60
	To 1.0 in. WC	0.50
	To 2.5 in. WC	0.22
	To 5 in. WC	0.14

* RSS of Non-Linearity, Hysteresis, and Non-Repeatability.

**Units calibrated at nominal 70 °F. Maximum thermal error computed from this datum.

Environmental Data

Temperature	
Operating* °F (°C)	0 to +175 (-18 to +79)
Storage °F (°C)	-65 to +250 (-54 to +121)

*Operating temperature limits of the electronics only. Pressure media temperatures may be considerably higher.

Physical Description

Case	Fire-Retardant Glass Filled Polyester (UL 94 V-0 Approved)
Mounting	Four screw holes on removable zinc plated steel base (designed for 2.75" snap track)
Electrical Connection	Screw Terminal Strip
Pressure Fittings	3/16" O.D. barbed brass pressure fitting for 1/4" push-on tubing
Zero and Span Adjustments	Accessible on top of case
Weight (approx.)	10 ounces

Pressure Media

Typically air or similar non-conducting gases.

Specifications subject to change without notice.

Electrical Data (Voltage)

Circuit	3-Wire (Com, Exc, Out)
Excitation	9 to 30 VDC
Output*	0 to 5 VDC**
Bidirectional output at zero pressure:	2.5 VDC**
Output Impedance	100 ohms

*Calibrated into a 50K ohm load, operable into a 5000 ohm load or greater.
**Zero output factory set to within ±50mV (±25 mV for optional accuracies).
**Span (Full Scale) output factory set to within ±50mV. (±25 mV for optional accuracies).

Electrical Data (Current)

Circuit	2-Wire
Output*	4 to 20mA**
Bidirectional output at zero pressure:	12mA**
External Load	0 to 800 ohms
Minimum supply voltage (VDC) = 9+ 0.02 x (Resistance of receiver plus line).	
Maximum supply voltage (VDC) = 30+ 0.004 x (Resistance of receiver plus line).	

*Calibrated at factory with a 24 VDC loop supply voltage and a 250 ohm load.
**Zero output factory set to within ±0.16mA (±0.08 mA for optional accuracies).
**Span (Full Scale) output factory set to within ±0.16mA (±0.08 mA for optional accuracies).

Outline Drawings

Code T1 Electrical Termination Dimensions

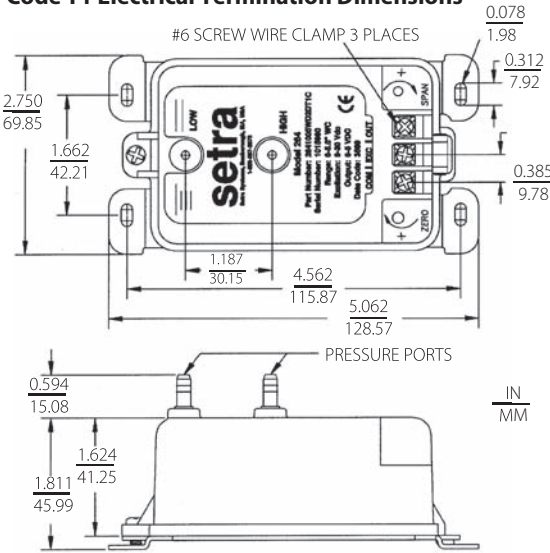

Optional 1/2" Conduit Electrical Enclosure Dimensions

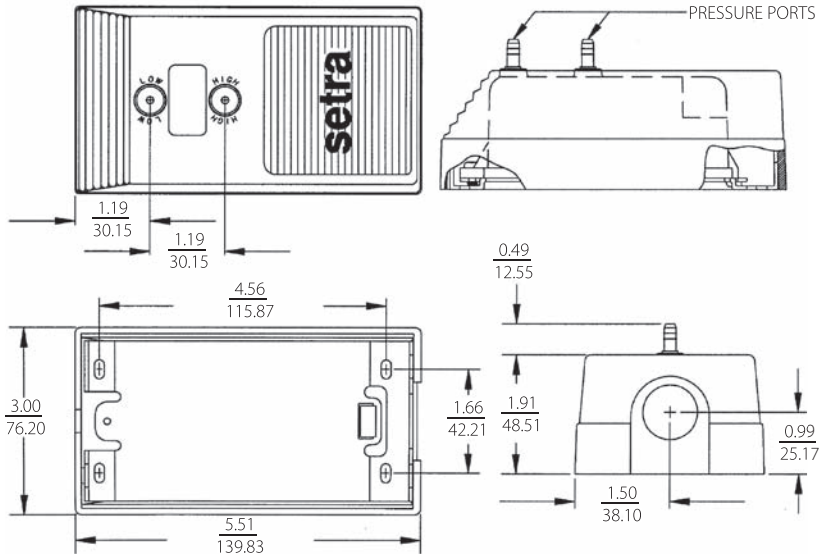

ORDERING INFORMATION

Code all blocks in table.

Example: Part No. 26412R5WD11T1C for a 264 Transducer 0 to 2.5 in. WC Range, 4 to 20 mA Output, Terminal Strip Electrical Connection, and ±1% Accuracy.

Model	Differential	Bidirectional	Output	Elec. Termination	Accuracy
2641 = 264	0R1WD = 0 to 0.1 in. WC R25WD = 0 to 0.25 in. WC 0R5WD = 0 to 0.5 in. WC 001WD = 0 to 1 in. WC 2R5WD = 0 to 2.5 in. WC 003WD = 0 to 3 in. WC 005WD = 0 to 5 in. WC 010WD = 0 to 10 in. WC 015WD = 0 to 15 in. WC 025WD = 0 to 25 in. WC 050WD = 0 to 50 in. WC 100WD = 0 to 100 in. WC	R05WB = ±0.05 in. WC 0R1WB = ±0.1 in. WC R25WB = ±0.25 in. WC 0R5WB = ±0.5 in. WC 001WB = ±1 in. WC 1R5WB = ±1.5 in. WC 2R5WB = ±2.5 in. WC 005WB = ±5 in. WC 7R5WB = ±7.5 in. WC 010WB = ±10 in. WC 025WB = ±25 in. WC 050WB = ±50 in. WC	11 = 4-20 mA 2D = 0 to 5 VDC	Standard T1 = Terminal Strip Optional A1 = 1/2" Conduit Enclosure	Standard C = ±1% FS Optional (w/Cal. Cert.) E = ±0.4% FS F = ±0.25% FS G = ±1% FS

Please contact factory for versions not shown.

While we provide application assistance on all Setra products, both personally and through our literature, it is the customer's responsibility to determine the suitability of the product in the application.

159 Swanson Road, Boxborough, MA 01719/Tel: 978-263-1400
Toll Free: 800-257-3872; Fax: 978-264-0292; email: sales@setra.com



SSP264 Rev.G 01/24/08