

Serial Communication via RS485 for Xi 80/410

of

Optris PIX Connect Software

(Rel. 3.15.3090.0)

A brief Overview

Introduction

The Xi 80 and Xi 410 supports a direct RS485 connection. RS485 interface is designed for high-speed serial data transmission over long distances and as a bidirectional bus system with up to 32 participants. An RS485 bus can be set up as a 2-wire as well as a 4-wire system. For the Xi 80/410 cameras, it is designed for a 2-wire system. A maximum cable length of 500 meters can be realized. At least a master and slave is necessary for communication. The master can be a PLC system and the slave is the camera.

RS485 is supported for Xi 80 cameras which have the hardware version 3001, firmware 3023 and at least the serial number which starts with 1812xxxx. For the Xi 410 it is working for all cameras starting at firmware version 3815. Here it is important that the communication is just working via Ethernet connection or in autonomous mode, but not with USB connection. Powering the device over USB and using it in autonomous mode is working as well.

The connection for RS485 can be done directly on the terminal block (A and B) which is provided in the scope of supply of the camera:

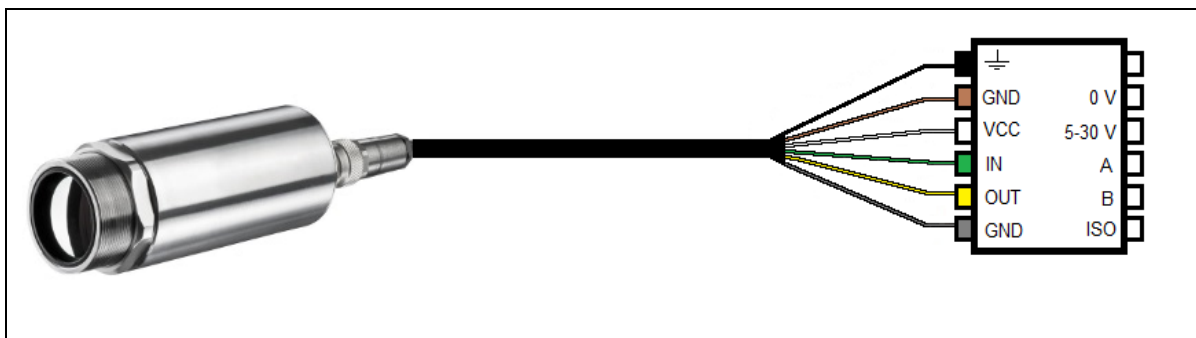

Figure 1: Camera connected with terminal block

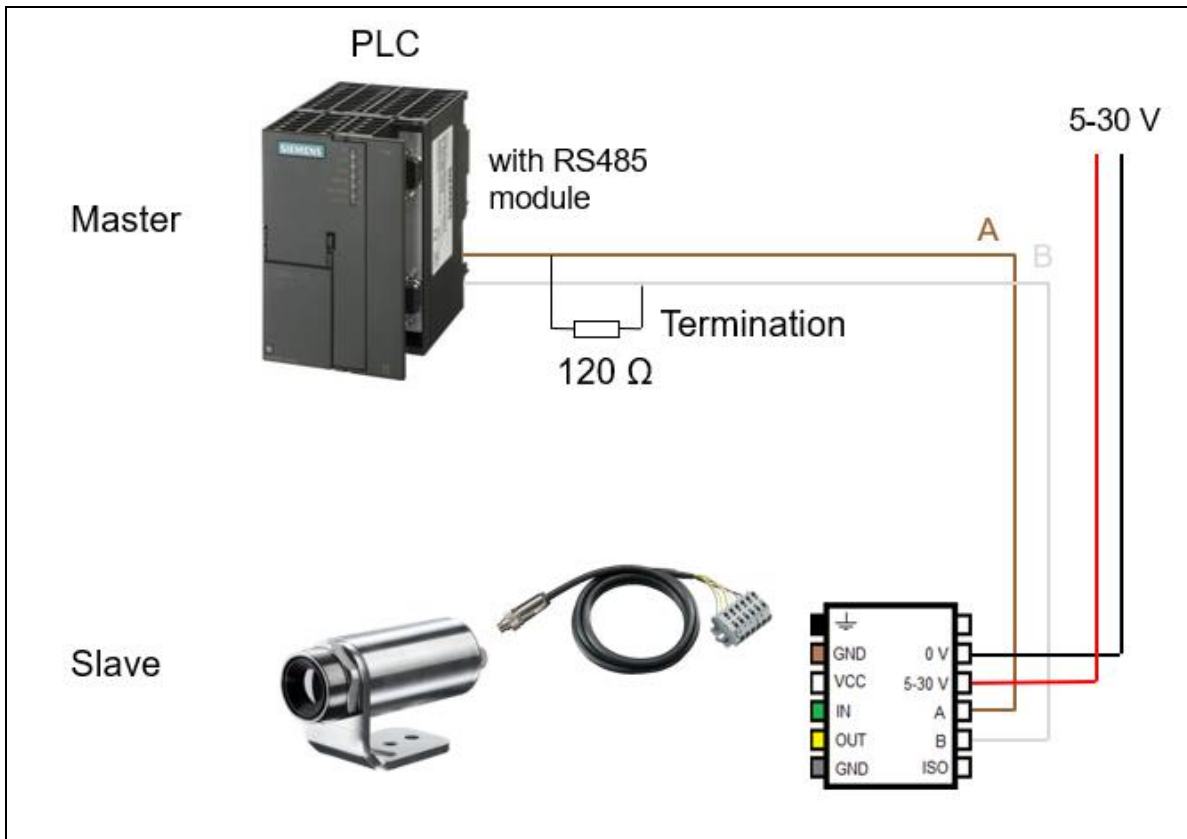

Figure 2: Connection of one camera with a PLC

RS485 Setup

To activate the serial communication with RS485, open the configuration dialog and enter the tab “**Device (PIF)**”. Choose under **PIF type** the mode “**Digital PIF**”.

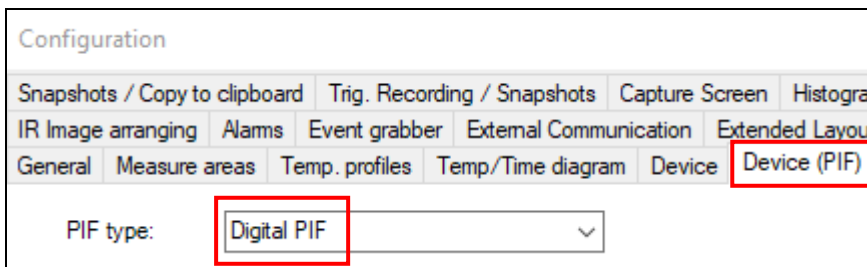

Figure 3: PIX Connect configuration in tab Device (PIF) – Digital PIF

Under **Serial communication on digital PIF** click on **Setup**.

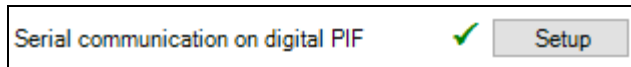

Figure 4: Serial communication on digital PIF - Setup

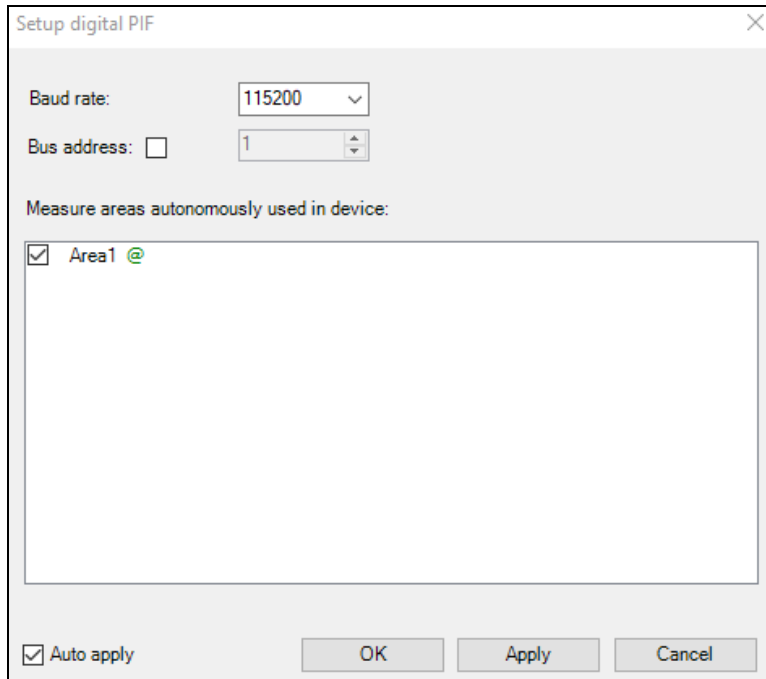

Figure 5: Setup of digital PIF

Select the **baud rate** that matches the baud rate of the other communication device. If more cameras are used in the same bus system, then also a **bus address** must be selected.

The other interface parameters are 8 data bits, no parity and one stop bit (8N1). This is mostly used on other communication devices too. The other station must support these interface parameters as well.

Command list

The following commands are implemented. Any command must end with a CR/LF (0x0D, 0x0A).

Read Commands	Description	Sample (Cmd./Answer)	Remarks
?T	Read temperature of main measure area	?T !T=24.9°C	
?T(i)	Read temperature of measure area with index i	?T(i) !T(i)=27.7°C	To get the count of indices use the command ?AreaCount first
?TMA	Read temperature of all measuring areas	!TMA=25.1;40.3;56.2;25.1;40.3; (example for reading out 5 measure areas)	
?TCO	Read temperature of all calculated objects	!TCO=25.1;40.3;56.2;25.1;40.3; (example for reading out 5 calculated objects)	
?C	Read chip temperature	?C !C=40.0°C	
?F	Read flag temperature	?F !C=32.0°C	
?I	Read internal temperature	?I !C=32.0°C	
?E	Read fixed emissivity value	?E !E=0.950	
?XG	Read fixed transmissivity value	?XG !XG=1.000	
?A	Read fixed ambient temperature value	?A A=23.0°C	
?SN	Read serial number of imager	?SN !SN=21044279	
?AreaCount	Read count of measure areas	?AreaCount !AreaCount=3	
?AreaMode(i)	Read mode ID of area i	?AreaMode(0) !AreaMode(0)=2	Id: 0(Min), 1(Max), 2(Average), 3(Distribution)
?AreaUseEmissivity(i)	Read if area i is using custom emissivity	?AreaUseEmissivity(0) !AreaUseEmissivity(0)=0	0=not used 1=used
?AreaEmissivity(i)	Read custom emissivity x of area i	?AreaEmissivity(0) !AreaEmissivity(0)=0.953	x = [0.000 ... 1.000]
?AreaDistributionModeRange(i)	Read the distribution range x1,x2 of area i	?AreaDistributionModeRange(0) !AreaDistributionModeRange(0)=20.0,50.0	Temperature range [x1 ... x2] for distribution mode x1 < x2
?RangeCount	Read count of existing temperature ranges	?RangeCount !RangeCount=3	
?RangeIndex	Read the index of the current temperature range	?RangeIndex !RangeIndex=1	
?RangeMin(i)	Read the low temperature of the temperature range with index i	?RangeMin(0) !RangeMin(0)=-20.0°C	To get the count of indices use the command ?RangeCount first

?RangeMax(i)	Read the high temperature of the temperature range with index i	?RangeMax(0) !RangeMax(0)=100.0°C	To get the count of indices use the command ?RangeCount first
?FWVer	Read the firmware and hardware version of the imager	?FWVer !FWVer=3022, 3001	
?Flag	Read flag state	?Flag !Flag=0	0 = flag is open 1 = flag is closed
?FocusmotorMinPos	Get minimum position of Xi's focus motor	?FocusmotorMinPos !FocusmotorMinPos=1500	
?FocusmotorMaxPos	Get maximum position of Xi's focus motor	?FocusmotorMaxPos !FocusmotorMaxPos=2500	
?FocusmotorPos	Get actual position of Xi's focus motor	?FocusmotorPos !FocusmotorPos=1700	

Set Commands	Description	Sample (Cmd./Answer)	Remarks
!Flag=0	Flag open/close	!Flag=0 !Flag=0	0 = open flag 1 = close flag
!E=x	Set fixed emissivity value	!E=0.950 !E=0.950	Valid range: 0.1 ... 1.1
!XG=x	Set fixed transmissivity value	!XG=1.000 !XG=1.000	Valid range: 0.1 ... 1.1
!A=x	Set fixed ambient temperature value	!A=23.0 !A=23.0°C	
!FocusmotorPos	Set actual position of Xi's focus motor	!FocusmotorPos=1500 !FocusmotorPos=1500	

Issue	Response
Unknown command	"Unknown Command! xxxx".
Known command with wrong syntax	"Bad Syntax!"
Known command with wrong index	"Wrong Index!"
Known commands with wrong parameter	"Wrong Parameter!"
Known commands is inappropriate for setting	"Inappropriate command!"
No Image available	"No Image!"
Known command, argument is out of valid range	"Out of range!"

Multi device – Addressing

There is also the possibility to use multiple devices. It is important that each camera needs an own bus address. This must be defined in the configuration dialog of the PIX Connect software as described under **RS485 Setup**.

If a bus address is defined in the configuration dialog Setup Digital PIF of PIX Connect, the camera will listen to commands starting with this address only. The heading address must always have three digits. Addresses within the range of 1 ... 999 are valid. Any camera connected to the bus must be configured with a different bus address. The answer also contains the address. If no device with the given address exists there will be no answer.

The following two figures are showing an installation example of multiple devices in a RS485 network.

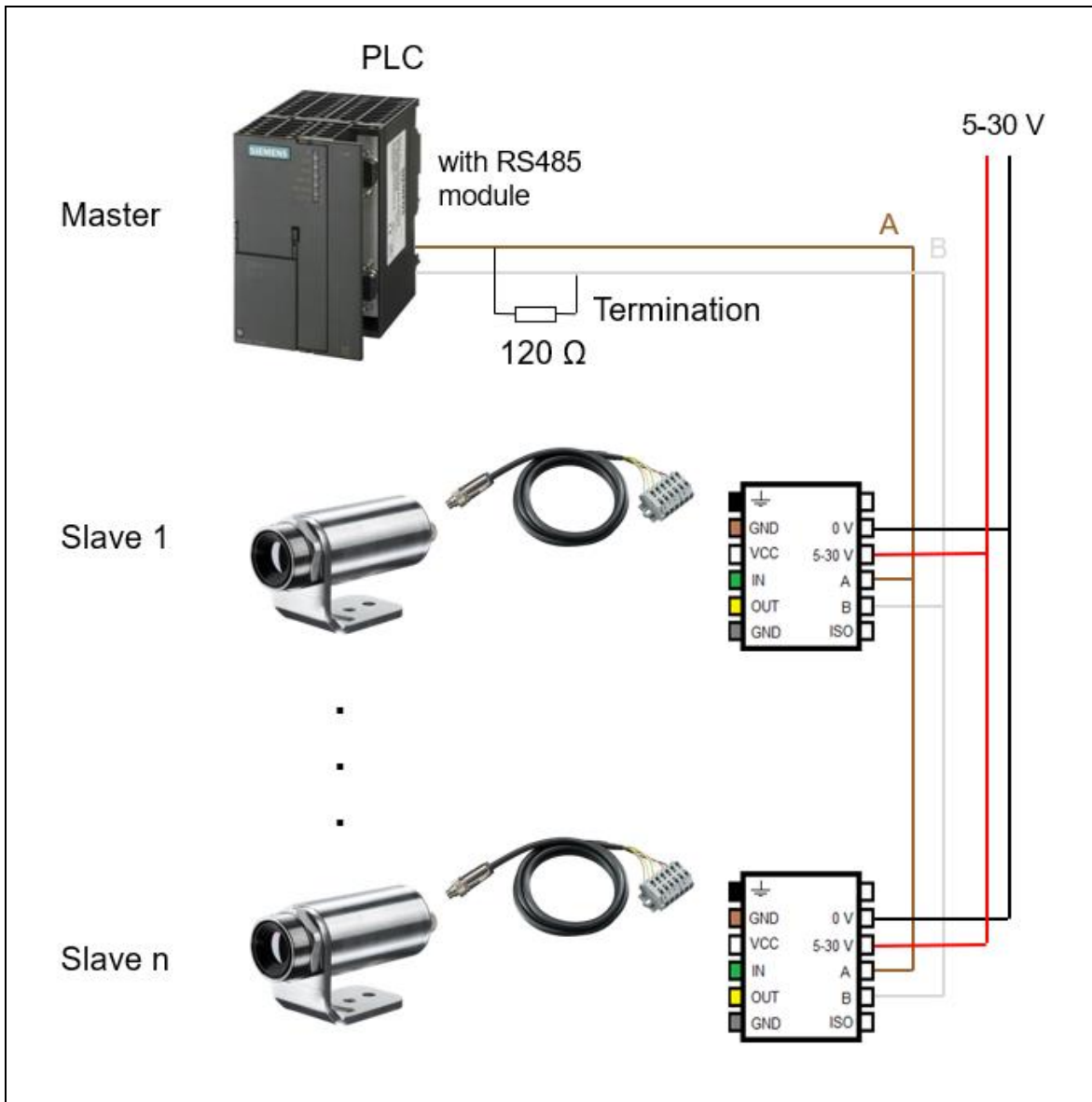

Figure 6: Example of multiple devices in RS485 – BUS config 1

Figure 6 shows the cameras (slaves) being connected after each other. It is important that the last camera which is connected must have the **terminating resistor** which is included in all cameras when they are delivered. For all cameras which are being used in between they currently need a special version of the camera. Please contact Optris for those cameras.

In this configuration, a terminating resistor must also be connected to the master.

Figure 7 shows the PLC system in the center and the cameras (slaves) are connected on the sides. It is important that the last camera which is connected must have the **terminating resistor** which is included in all cameras when they are delivered. For all cameras which are being used in between they currently need a special version of the camera. Please contact Optris for those cameras.

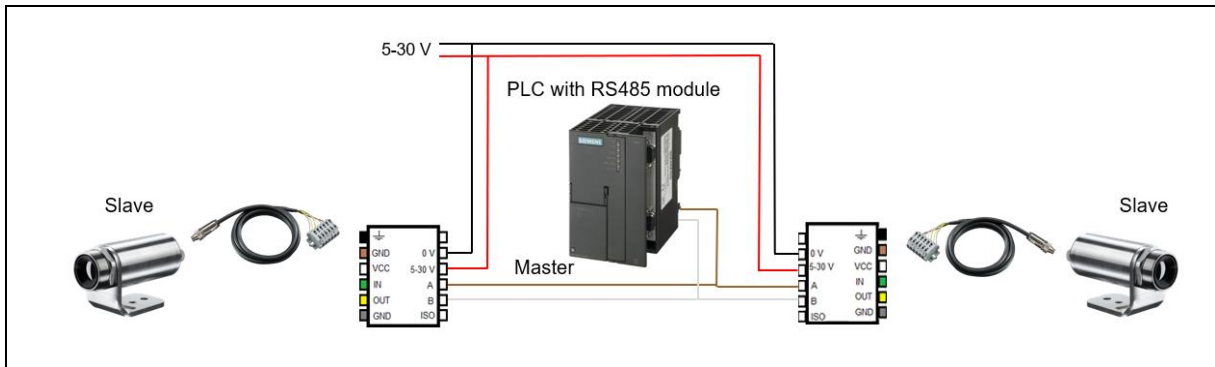

Figure 7: Example of multiple devices in RS485 - BUS config 2

Examples:

005?T	Read the temperature of the main measure area of device with address 005	Answer: 005!T=25.7°C
010!Flag=1	Close the flag of device with address 10	Answer: 010!Flag=1

Berlin, 03.08.2021