

# Single-Phase Right/Left Terminal SSR with Integrated Heatsink



## SRHL1 Series PRODUCT MANUAL

For your safety, read and follow the considerations written in the instruction manual, other manuals and Autonics website.

The specifications, dimensions, etc. are subject to change without notice for product improvement. Some models may be discontinued without notice.

### Features

- Rated input voltage : 10 - 30 VDC $\equiv$ , 90 - 240 VAC $\sim$
- Rated load voltage : 24 - 240 VAC $\sim$ , 48 - 480 VAC $\sim$
- Rated load current : 10 A, 15 A, 20 A, 25 A, 40 A
- Zero cross turn-on / Random turn-on models available
- Input indicator (green)
- Overheat prevention function
  - Rated load current 10 / 15 / 20 / 25 A: alarm indicator (red)
  - Rated load current 40 A: alarm output indicator (red), alarm output
- DIN Rail or panel mount installation

### Safety Considerations

- Observe all 'Safety Considerations' for safe and proper operation to avoid hazards.
- $\triangle$  symbol indicates caution due to special circumstances in which hazards may occur.

**$\triangle$  Warning** Failure to follow instructions may result in serious injury or death.

- 01. Fail-safe device must be installed when using the unit with machinery that may cause serious injury or substantial economic loss.** (e.g., nuclear power control, medical equipment, ships, vehicles, railways, aircraft, combustion apparatus, safety equipment, crime/disaster prevention devices, etc.)  
Failure to follow this instruction may result in personal injury, economic loss or fire.
- 02. Do not use the unit in the place where flammable/explosive/corrosive gas, high humidity, direct sunlight, radiant heat, vibration, impact or salinity may be present.**  
Failure to follow this instruction may result in explosion or fire.
- 03. Install the unit on DIN rail or panel to use.**  
Failure to follow this instruction may result in fire or electric shock.
- 04. Do not connect, repair, or inspect the unit while connected to a power source.**  
Failure to follow this instruction may result in fire or electric shock.
- 05. Check 'Connections' before wiring.**  
Failure to follow this instruction may result in fire.
- 06. Do not disassemble or modify the unit.**  
Failure to follow this instruction may result in fire or electric shock.

**$\triangle$  Caution** Failure to follow instructions may result in injury or product damage.

- 01. Use the unit within the rated specifications.**  
Failure to follow this instruction may result in fire or product damage.
- 02. Use a dry cloth to clean the unit, and do not use water or organic solvent.**  
Failure to follow this instruction may result in fire or electric shock.
- 03. Keep the product away from metal chip, dust, and wire residue which flow into the unit.**  
Failure to follow this instruction may result in fire or product damage.
- 04. Since leakage current still flows right after turning off the power or in the output OFF status, do not touch the load terminal.**  
Failure to follow this instruction may result in electric shock.

### Cautions during Use

- Follow instructions in 'Cautions during Use'.  
Otherwise, it may cause unexpected accidents.
- 10 - 30 VDC $\equiv$  model power supply should be insulated and limited voltage/current or Class 2, SELV power supply device.
- Install the unit in the well ventilated place.
- Ground the heatsink, panel, or DIN rail. Failure to follow this instruction may result in electric shock.
- While supplying power to the load or right after turning off the power of the load, do not touch the body and heat sink. Failure to follow this instruction may result in burn due to high temperature of the surface.
- In order to protect the product from the short-circuit current of the load, use rapid fuse of which I<sup>2</sup>t is under the 1/2 of SSR I<sup>2</sup>t. When short-circuited, replace the fuse to those of same specification with the used rapid fuse.
- Install dummy resistance in parallel with the load, to keep the sum of current flowing in the load and dummy resistance being over SSR minimum load current.
- When using random turn-on model for phase control, install noise filter between the load and the power of the load.
- Do not use near the equipment which generates strong magnetic force or high frequency noise.
- This unit may be used in the following environments.
  - Indoors (in the environment condition rated in 'Specifications')
  - Altitude max. 2,000 m
  - Pollution degree 2
  - Installation category III

## Ordering Information

This is only for reference, the actual product does not support all combinations. For selecting the specified model, follow the Autonics website.

SRHL1 - ① ② ③ ④

### ① Rated input voltage

1: 4 - 30 VDC=  
4: 90 - 240 VAC~

### ② Rated load voltage

2: 24 - 240 VAC~  
4: 48 - 480 VAC~

### ③ Rated load current

Number: Rated load current (unit: A)

### ④ Function

No-mark: Zero cross turn-on  
R: Random turn-on

## Product Components

- Product
- Instruction manual

## Dimensions

- Unit: mm, For the detailed drawings, follow the Autonics website.

**A** Input indicator (green)    **B** Alarm indicator (red)

- When installing to the panel, tightening the screw with a torque of 1.8 to 2.5 N.m.

### Rated load current 10 / 15 / 20 / 25 A

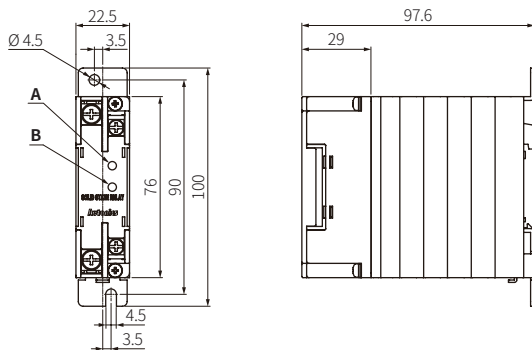

### Rated load current 40 A

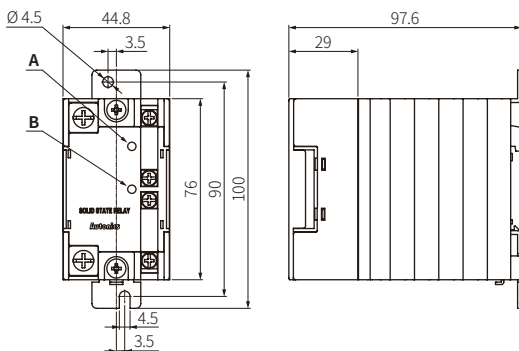

### Panel cut-out

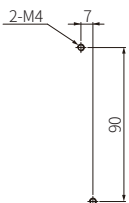

## Cautions during Installation

### Caution High Temperature

While supplying power to the load or right after turning off the power of the load, do not touch the body and heat sink. Failure to follow this instruction may result in burn due to high temperature of the surface.

### Spacing

- When installing multiple SSRs, be sure to keep space between SSRs for heat radiation.
- When installing SSRs horizontally (input part and output part on the same height), be sure to supply less than 50 % of the rated load current.

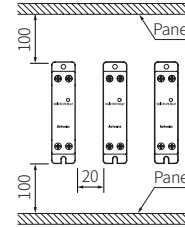

### DIN rail mounting

- For attachment, hang the upper part of the Rail lock on the rear of the product to the DIN rail, and push the product toward the DIN rail.
- For detachment, Press the product down, and pull it forward.

### Grounding

- Ground the DIN rail.

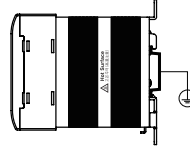

## Connections

- Alarm output terminal (AL) is for the rated load current 40 A model only.

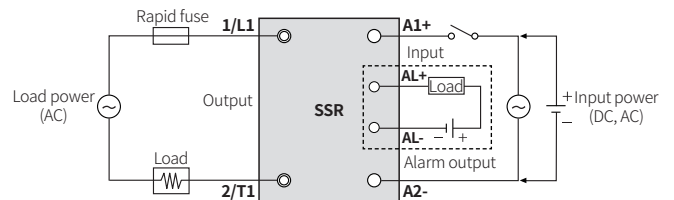

## Cautions for Wiring

- Unit: mm, When connecting the wire to the terminal, use the round crimp terminal.

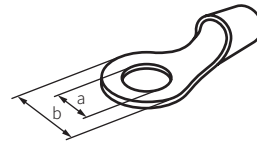

Size	Input	Output	
Rated load current	10 / 15 / 20 / 25 / 40 A	10 / 15 / 20 / 25 A	40 A
a	≥ 3.5 mm	≥ 4.0 mm	≥ 5.0 mm
b	≤ 7.0 mm	≤ 9.0 mm	≤ 12.0 mm

## Specifications

### Input

Rated input voltage range	10 - 30 VDC≡	90 - 240 VACrms~ (50 / 60 Hz)
Allowable input voltage range	9 - 32 VDC≡	85 - 264 VACrms~ (50 / 60 Hz)
Max. input current	15 mA	22 mA
Operating voltage	≥ 9 VDC≡	≥ 85 VACrms~
Releasing voltage	≤ 1 VDC≡	≤ 10 VACrms~
Operating time	Zero cross turn-on	≤ 0.5 cycle of load power + 1 ms
	Random turn-on	≤ 1 ms
Releasing time	Zero cross turn-on	≤ 0.5 cycle of load power + 1 ms
	Random turn-on	≤ 2 cycle of load power + 1 ms

### Output

Rated load voltage range	24 - 240 VACrms~ (50 / 60 Hz)					
Allowable load voltage range	24 - 264 VACrms~ (50 / 60 Hz)					
Rated load current	Resistive load (AC-51) <sup>01)</sup>	10 Arms	15 Arms	20 Arms	25 Arms	40 Arms
Min. load current		0.15 Arms	0.15 Arms	0.2 Arms	0.2 Arms	0.5 Arms
Max. 1 cycle surge current (60 Hz)		160 A	160 A	250 A	250 A	400 A
Max. non-repetitive surge current (I <sup>2</sup> t, t = 8.3 ms)		130 A <sup>2</sup> s	130 A <sup>2</sup> s	300 A <sup>2</sup> s	300 A <sup>2</sup> s	910 A <sup>2</sup> s
Peak voltage (non-repetitive)		600 V				
Leakage current (Ta = 25 °C)		≤ 10 mA Arms (240 VAC~/60 Hz)				
Output ON voltage drop [Vpk] (max. load current)		≤ 1.6 V				
Static off state dv/dt		500 V/μs				

Rated load voltage range	48 - 480 VACrms~ (50 / 60 Hz)					
Allowable load voltage range	48 - 528 VACrms~ (50 / 60 Hz)					
Rated load current	Resistive load (AC-51) <sup>01)</sup>	10 Arms	15 Arms	20 Arms	25 Arms	40 Arms
Min. load current		0.5 Arms				
Max. 1 cycle surge current (60 Hz)		300 A	300 A	500 A	500 A	500 A
Max. non-repetitive surge current (I <sup>2</sup> t, t = 8.3 ms)		350 A <sup>2</sup> s	350 A <sup>2</sup> s	1000 A <sup>2</sup> s	1000 A <sup>2</sup> s	1000 A <sup>2</sup> s
Peak voltage (non-repetitive)		1200 V (zero cross turn-on), 1000 A (random turn-on)				
Leakage current (Ta = 25 °C)		≤ 10 mA Arms (480 VAC~/60 Hz)				
Output ON voltage drop [Vpk] (max. load current)		≤ 1.6 V				
Static off state dv/dt		500 V/μs				

01) AC-51 is utilization category at IEC60947-4-3.

### Overheat prevention function

Overheat prevention function is when SSR internal temperature is overheated, the load output is cut off to prevent internal device damage and also the alarm indicator and alarm output turn ON.

The operating temperature of the overheat prevention function may vary depending on the external environment, product configuration, and load current.

Rated input voltage range	10 - 30 VDC≡	90 - 240 VACrms~ (50 / 60 Hz)
Load voltage	≤ 30 VDC≡	≤ 30 VDC≡
Load current	≤ 50 mA	≤ 50 mA
Turn-off time	≤ 50 ms	≤ 100 ms

- Alarm output is only for the rated load current 40 A model, in case of the rated load current 10 / 15 / 20 / 25 A model, the alarm indicator turns ON without the alarm output.
- To clear alarm, cut off the input signal during over the alarm output return time at the rated ambient temperature.

### General specifications

Dielectric strength (Vrms)	Input-output: 2500 VAC~ 50 / 60 Hz for 1 min Input / output-case: 4000 VAC~ 50 / 60 Hz for 1 min
Insulation resistance	Input-output, input/output-case : ≥ 100 MΩ (500 VDC≡ megger)
Indicator	Input indicator (green), alarm indicator (red)
Vibration	0.75 mm double amplitude at frequency of 10 to 55 Hz (for 1 min) in each X, Y, Z direction for 1 hour
Vibration (malfunction)	0.5 mm double amplitude at frequency of 10 to 55 Hz (for 1 min) in each X, Y, Z direction for 10 min
Shock	300 m/s <sup>2</sup> (≈ 30 G) in each X, Y, Z direction for 3 times
Shock (malfunction)	100 m/s <sup>2</sup> (≈ 10 G) in each X, Y, Z direction for 3 times
Ambient temperature <sup>01)</sup>	-30 to 70 °C, storage: -30 to 100 °C (no freezing or condensation)
Ambient humidity	45 to 85 %RH, storage: 45 to 85 %RH (no freezing or condensation)
Input terminal connection	≥ 1 × 0.5 mm <sup>2</sup> (1 × AWG 20), ≤ 1 × 4 mm <sup>2</sup> (1 × AWG 12) or ≤ 2 × 1.5 mm <sup>2</sup> (2 × AWG 16)
Output terminal connection <sup>02)</sup>	Rated load current 10 / 15 / 20 / 25 A : ≥ 1 × 0.75 mm <sup>2</sup> (1 × AWG 18), ≤ 1 × 6 mm <sup>2</sup> (1 × AWG 10) or ≤ 2 × 2.5 mm <sup>2</sup> (2 × AWG 14) Rated load current 40 A : ≥ 1 × 1.5 mm <sup>2</sup> (1 × AWG 16), ≤ 1 × 16 mm <sup>2</sup> (1 × AWG 6) or ≤ 2 × 6 mm <sup>2</sup> (2 × AWG 10)
Input terminal fixed torque	0.75 to 0.95 N m
Output terminal fixed torque	Rated load current 10 / 15 / 20 / 25 A: 1.0 to 1.35 N m Rated load current 40 A: 1.6 to 2.2 N m
Approval	CE, RoHS, ENEC
Weight (packaged)	Rated load current 10 / 15 / 20 / 25 A: ≈ 192 g (≈ 270 g) Rated load current 40 A: ≈ 372 g (≈ 468 g)

01) See the 'SSR Derating Curve' because the capacity of the rated load current is differ depending on the ambient temperature.

02) Connect the wire met the capacity of the load current to the output terminal.

## SSR Derating Curve

- Be aware that the ambient temperature and the derating curve is different by the rated input voltage when using the product.
- △ Since the effectiveness of the heat radiation is decreased when SSRs are installed closely, be sure to supply less than 50 % of the rated load current.
- SSR derating curves obtained approval from the UL certification authority.

### SRHL1-1210 / 1410 / 1410R / 4210 / 4410

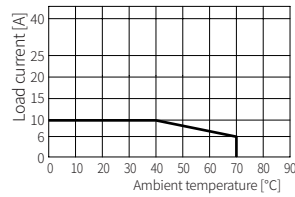

### SRHL1-1215 / 1415 / 1415R / 4215 / 4415

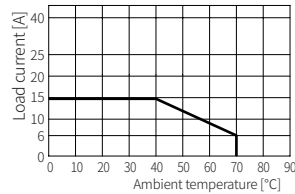

### SRHL1-1220 / 1420 / 1420R / 4220 / 4420

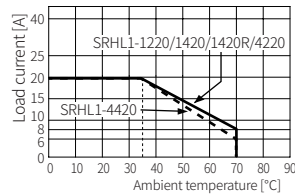

### SRHL1-1225 / 1425 / 1425R / 4225 / 4425

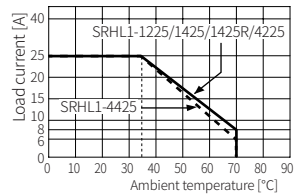

### SRHL1-1240 / 1440 / 1440R / 4240 / 4440

