

# Operating Instructions

## Field Xpert SMT70

Universal, high-performance tablet PC for device configuration in Ex Zone 2 and non-Ex areas



## Change history

Product version	Operating Instructions	Changes	Comments
1.00.xx	BA01709S/04/EN/01.17	-	-
1.02.xx	BA01709S/04/EN/02.18	New chapter 8.5	HART via PROFINET via Fieldgate PAM SFG600

# Table of contents

<b>1</b>	<b>About this document</b> .....	<b>4</b>		
1.1	Document function .....	4		
1.2	Symbols used .....	4		
1.3	Acronyms used .....	6		
1.4	Documentation .....	6		
1.5	Registered trademarks .....	6		
<b>2</b>	<b>Basic safety instructions</b> .....	<b>7</b>		
2.1	Requirements for the personnel .....	7		
2.2	Designated use .....	7		
2.3	Workplace safety .....	7		
2.4	Operational safety .....	8		
2.5	Product safety .....	8		
2.6	IT security .....	8		
<b>3</b>	<b>Product description</b> .....	<b>8</b>		
3.1	Product design .....	12		
3.2	Application .....	12		
3.3	Licence model .....	13		
<b>4</b>	<b>Incoming acceptance and product identification</b> .....	<b>14</b>		
4.1	Incoming acceptance .....	14		
4.2	Product identification .....	15		
4.3	Storage and transport .....	16		
<b>5</b>	<b>Installation</b> .....	<b>16</b>		
5.1	System requirements .....	16		
5.2	Installing the software .....	16		
5.3	Updating the software .....	16		
5.4	Removing the software .....	17		
<b>6</b>	<b>Software operation</b> .....	<b>17</b>		
6.1	Status indicators .....	17		
6.2	Shutting down the tablet PC .....	17		
6.3	Switching off the tablet PC .....	18		
6.4	Security screen .....	18		
<b>7</b>	<b>Commissioning</b> .....	<b>18</b>		
7.1	Inserting the battery .....	19		
7.2	Charging the battery .....	20		
7.3	Switching on the tablet PC .....	20		
7.4	Connecting the AC adapter .....	20		
<b>8</b>	<b>Operation</b> .....	<b>20</b>		
8.1	How to start .....	21		
8.2	Establishing a connection to the device .....	21		
8.3	Information and software settings .....	26		
8.4	Additional information about the software .....	30		
8.5	Fieldgate PAM SFG600 HART via PROFINET .....	31		
<b>9</b>	<b>Diagnostics and troubleshooting</b> .....	<b>32</b>		
9.1	General troubleshooting .....	32		
<b>10</b>	<b>Maintenance</b> .....	<b>33</b>		
10.1	Replacing the battery .....	33		
10.2	Cleaning .....	34		
<b>11</b>	<b>Repair</b> .....	<b>34</b>		
11.1	General notes .....	34		
11.2	Spare parts .....	34		
11.3	Return .....	35		
11.4	Disposal .....	35		
<b>12</b>	<b>Accessories</b> .....	<b>35</b>		
<b>13</b>	<b>Technical data</b> .....	<b>35</b>		
<b>14</b>	<b>Appendix</b> .....	<b>36</b>		
14.1	Federal Communication Commission (FCC) .....	36		
14.2	Canada, Industry Canada (IC) Notices / Canada, avis d'Industry Canada (IC) .....	36		
14.3	Warning Explosion Hazard .....	36		
14.4	Class 1 laser product .....	37		





# 1 About this document

## 1.1 Document function







These Operating Instructions contain all the information that is required in various phases of the life cycle of the device: from product identification, incoming acceptance and storage, to mounting, connection, operation and commissioning through to troubleshooting, maintenance and disposal.





## 1.2 Symbols used

### 1.2.1 Safety symbols















Symbol	Meaning
	<b>DANGER!</b> This symbol alerts you to a dangerous situation. Failure to avoid this situation will result in serious or fatal injury.
	<b>WARNING!</b> This symbol alerts you to a dangerous situation. Failure to avoid this situation can result in serious or fatal injury.
	<b>CAUTION!</b> This symbol alerts you to a dangerous situation. Failure to avoid this situation can result in minor or medium injury.
	<b>NOTE!</b> This symbol contains information on procedures and other facts which do not result in personal injury.







### 1.2.2 Symbols for certain types of information

Symbol	Meaning
	<b>Permitted</b> Procedures, processes or actions that are permitted.
	<b>Preferred</b> Procedures, processes or actions that are preferred.
	<b>Forbidden</b> Procedures, processes or actions that are forbidden.
	<b>Tip</b> Indicates additional information.
	Reference to documentation.
	Reference to page.
	Reference to graphic.

Symbol	Meaning
	Notice or individual step to be observed.
	Series of steps.
	Result of a step.
	Help in the event of a problem.
	Visual inspection.

### 1.2.3 Field Xpert symbols

Symbol	Meaning
	Switch tablet on and off.
	Windows button
	Wireless communication (WLAN, WWAN, GPS, Bluetooth)
	Battery
	Open the home screen of the device configuration software.
	Jump back to the last page opened.
	Information and software settings.
	Additional information about the software.
	Minimize the program.
	Enable full screen.
	Disable full screen.
	Close the program.
	Scroll up
	Scroll down

Symbol	Meaning
	Update
	Expand information.
	Collapse information.
	Connect automatically
	Connect with wizard (manual connection)
	Connect with Remote Wizard

### 1.3 Acronyms used

Acronyms	Explanation
DFS	Dynamic Frequency Selection
FCC	Federal Communications Commission
HF	High frequency [RF = radio frequency]
SD	Secure Digital
WWAN	Wireless Wide Area Network

### 1.4 Documentation

#### Field Xpert SMT70

Technical Information TI01342S/04/EN

#### Field Xpert SMT77

- Technical Information TI01418S/04/EN
- Operating Instructions BA01923S/04/EN

#### Fieldgate PAM SFG600

- Technical Information TI01408S/04/EN
- Brief Operating Instructions KA01400S/04/EN

### 1.5 Registered trademarks

Windows 10 Pro® is a registered trademark of Microsoft Corporation, Redmond, Washington, USA.

Intel® Core™ is a registered trademark of Intel Corporation, Santa Clara, USA.

Durabook is a registered trademark of Twinhead International Corp., Taiwan.

FOUNDATION™ Fieldbus is the trademark of the FieldComm Group, Austin, TX 78759, USA.

HART®, WirelessHART® is the registered trademark of the FieldComm Group, Austin, TX 78759, USA.

PROFIBUS® is a registered trademark of the PROFIBUS User Organization, Karlsruhe/Germany.

Modbus is the registered trademark of Modicon, Incorporated.

All other brand and product names are trademarks or registered trademarks of the companies and organizations in question.

## 2 Basic safety instructions



The Operating Instructions supplied with the device and containing the safety instructions of the tablet PC manufacturer must be observed.

### 2.1 Requirements for the personnel

The personnel for installation, commissioning, diagnostics and maintenance must fulfill the following requirements:

- ▶ Trained, qualified specialists must have a relevant qualification for this specific function and task.
- ▶ Are authorized by the plant owner/operator.
- ▶ Are familiar with federal/national regulations.
- ▶ Before starting work, read and understand the instructions in the manual and supplementary documentation as well as the certificates (depending on the application).
- ▶ Follow instructions and comply with basic conditions.

The operating personnel must fulfill the following requirements:

- ▶ Are instructed and authorized according to the requirements of the task by the facility's owner-operator.
- ▶ Follow the instructions in this manual.

### 2.2 Designated use

The tablet PC for device configuration enables mobile plant asset management in hazardous and non-hazardous areas. It is suitable for commissioning and maintenance staff to manage field instruments with a digital communication interface and to record progress. This tablet PC is designed as a complete solution and is an easy-to-use, touch-enabled tool which can be used to manage field instruments during their entire life cycle. It provides extensive, pre-installed driver libraries and offers access to the "Industrial Internet of Things" as well as to information and documentation during the entire life cycle of the device. The tablet PC offers a modern software user interface and the option of online updates based on a secure Microsoft Windows 10 multi-functional environment.

### 2.3 Workplace safety

The tablet PC is used for device configuration. Incorrect configurations may lead to unwanted or hazardous situations in a plant. The device configuration software is already installed on

the tablet PC upon delivery. These Operating Instructions describe how to commission and operate the tablet PC.



- Commissioning → 📄 18
- Operation → 📄 20

## 2.4 Operational safety

Risk of injury!

- ▶ Operate the device in proper technical condition and fail-safe condition only.
- ▶ The operator is responsible for interference-free operation of the device.

### Modifications to the device

Unauthorized modifications to the device are not permitted and can lead to unforeseeable dangers:

- ▶ If, despite this, modifications are required, consult with Endress+Hauser.

### Repair

To ensure continued operational safety and reliability:

- ▶ Carry out repairs on the device only if they are expressly permitted.
- ▶ Observe federal/national regulations pertaining to repair of an electrical device.
- ▶ Use only original spare parts and accessories from the manufacturer.

## 2.5 Product safety

The tablet PC is designed in accordance with good engineering practice to meet state-of-the-art safety requirements, has been tested, and left the factory in a condition in which it is safe to operate.

It fulfills general safety requirements and legal requirements. It also conforms to the EC directives listed in the device-specific EC Declaration of Conformity. The manufacturer confirms this by affixing the CE mark to the device.

## 2.6 IT security

We only provide a warranty if the device is installed and used as described in the Operating Instructions. The device is equipped with security mechanisms to protect it against any inadvertent changes to the device settings.

IT security measures in line with operators' security standards and designed to provide additional protection for the device and device data transfer must be implemented by the operators themselves.

# 3 Product description

With an ultra-compact form factor, the tablet PC meets the most demanding requirements, such as ingress protection (IP65) and shock resistance (4-foot drop-test and MIL-STD 810G). The additional screen protector offers complete protection in harsh working environments.



The tablet PC's good ergonomic features also protect workers' health, keeping physical strain to a minimum.

With the increasing popularity of 4G/LTE connectivity in hazardous areas, the tablet PC ensures swift and seamless access to data. However, in situations where not even WLAN is available, the optional docking station with an Ethernet interface gives the tablet PC the necessary flexibility to link into existing network infrastructures. In addition, the latest Bluetooth standards are also supported.

After use in the field, the tablet PC can be used as an office PC with the optional office docking station, allowing the tablet to be seamlessly integrated into the office and business networks.

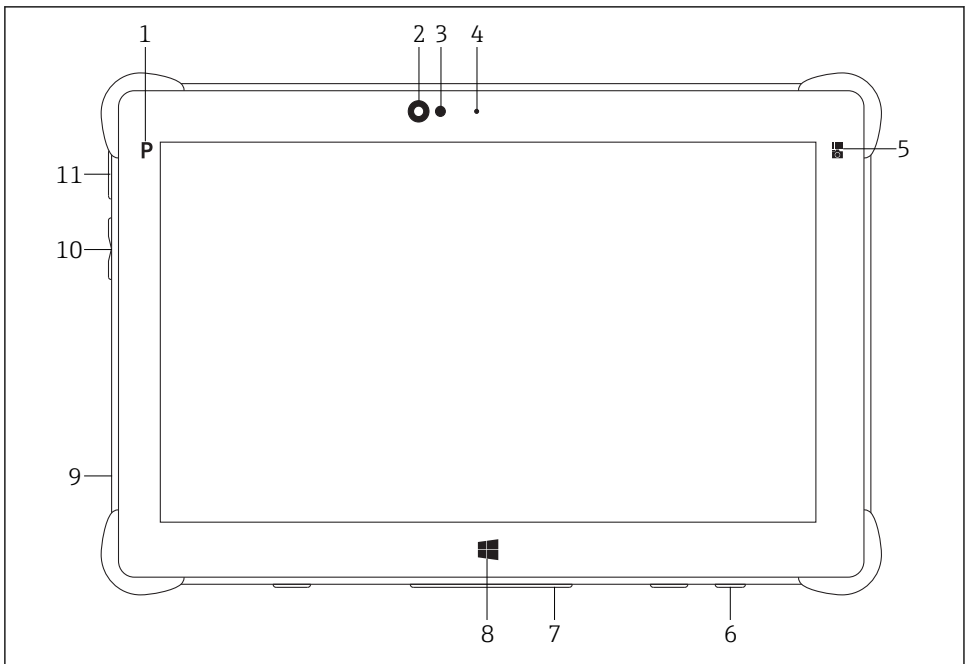

**1** Front view of tablet PC

- 1 Program button
- 2 Front camera
- 3 Ambient light sensor
- 4 Microphone
- 5 Function key
- 6 DC socket (underside)
- 7 Dock connector (underside)
- 8 Windows button
- 9 Slot for Kensington lock (left side)
- 10 Volume buttons (left side)
- 11 On/off button (left side)

<b>Component</b>	<b>Description</b>
Program button	Go to user-defined program
Front camera	For video recordings (e.g. at video conferences)
Ambient light sensor	Measures the current ambient lighting conditions
Microphone	To record ambient sounds
Function key	The key function can be assigned via the "Quick Menu"
DC socket	For connecting the power adapter
Dock connector	For connecting the tablet PC to a docking station
Windows button	Launch the Windows start screen
Slot for Kensington lock	For connecting a Kensington-compatible security lock
Volume buttons	For setting the volume
On/off button	For switching the tablet PC on or off

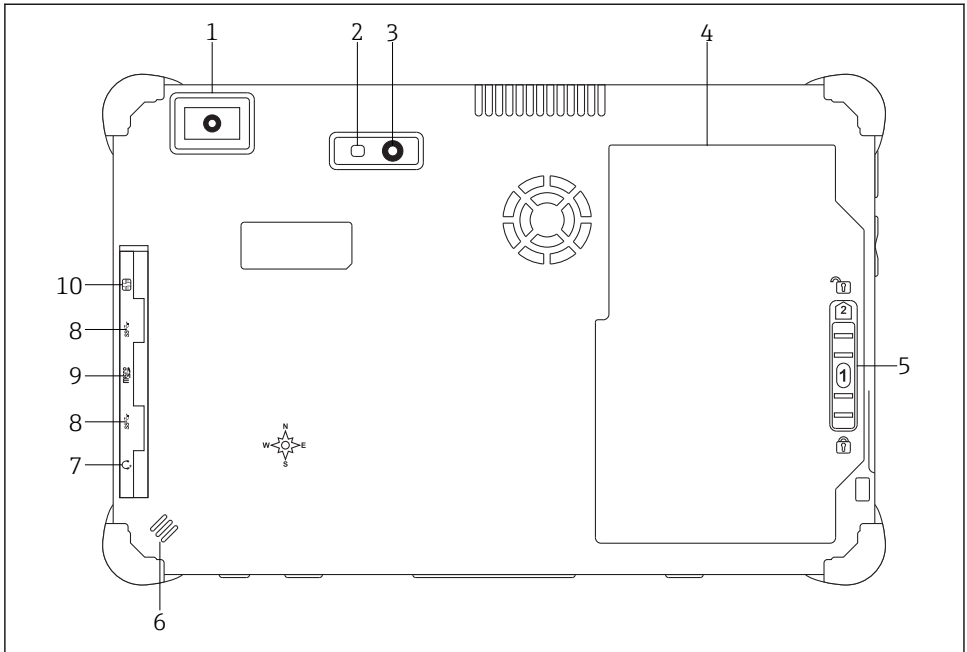

 2 Rear view of tablet PC

- 1 Barcode scanner
- 2 Camera LED flash
- 3 Camera
- 4 Battery compartment
- 5 Button to unlock the battery compartment
- 6 Loudspeaker
- 7 Combined audio jack
- 8 2 x USB 3.0
- 9 Memory card slot for Micro SD memory cards
- 10 SIM card slot

Component	Description
Barcode scanner	For scanning barcodes.
Camera LED flash	For additional lighting in poor light.
Camera	For taking pictures.
Battery compartment	Contains the battery.
Button to unlock the battery compartment	Press down the button and hold to unlock the battery compartment.
Loudspeaker	For sound
SIM card slot	For inserting a SIM card for WWAN (LTE+GPS).

Component	Description
2 x USB 3.0	For connecting USB 3.0 peripheral devices.  <div style="background-color: #FFA500; padding: 2px; display: inline-block;"><b>⚠ WARNING</b></div> <b>The use of the USB ports in the hazardous area is not permitted</b> and can cause an explosion. ▶ In the hazardous area, always use an Ex-tablet with the MACTek VIATOR Bluetooth HART modem.
Memory card slot	For inserting Micro SD memory cards, and SD, SDXC, SDHC memory cards using an adapter.
Combined audio jack	For connecting headphones, external loudspeakers or a microphone.

### 3.1 Product design

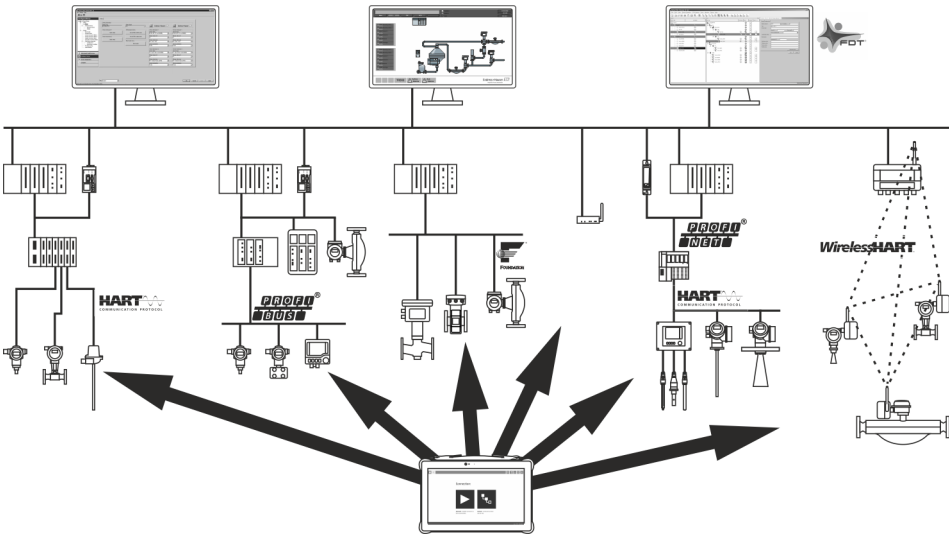

3 Network architecture

### 3.2 Application

The tablet PC for device configuration enables mobile plant asset management in hazardous and non-hazardous areas. It is suitable for commissioning and maintenance staff to manage field instruments with a digital communication interface and to record progress. This tablet PC is designed as a complete solution and is an easy-to-use, finger-operated tool which can be used to manage field instruments during their entire life cycle. It provides pre-installed driver libraries and offers access to the "Industrial Internet of Things" as well as to information and documentation during the entire life cycle of the device. The tablet PC offers a modern software user interface and the option of online updates based on a secure Microsoft Windows 10 multi-functional environment.

### 3.3 Licence model

The device configuration software is already installed on the tablet PC upon delivery.

To use the software as designated, the software must be activated. A user account is required in the Endress+Hauser software portal for this purpose. This account might first need to be created via the "Create account" function.

#### Activating the device configuration software package

1. Double-click **Field Xpert SMT70** on the start screen.
  - ↳ The software licensing page opens.

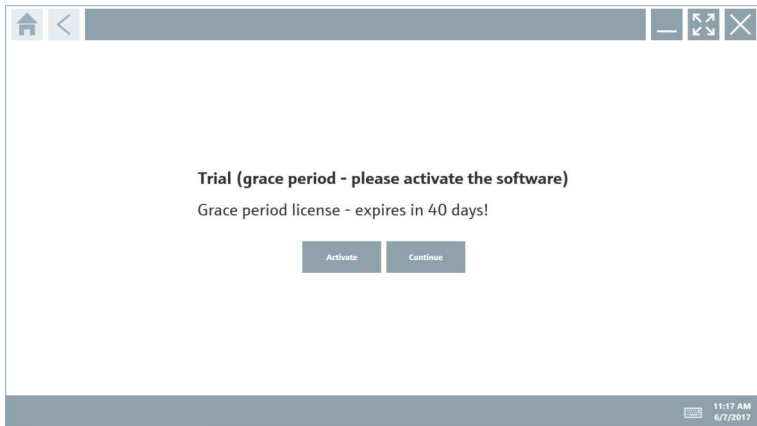

2. Click **Activate**.
  - ↳ The dialog box where you can enter the software portal data opens.

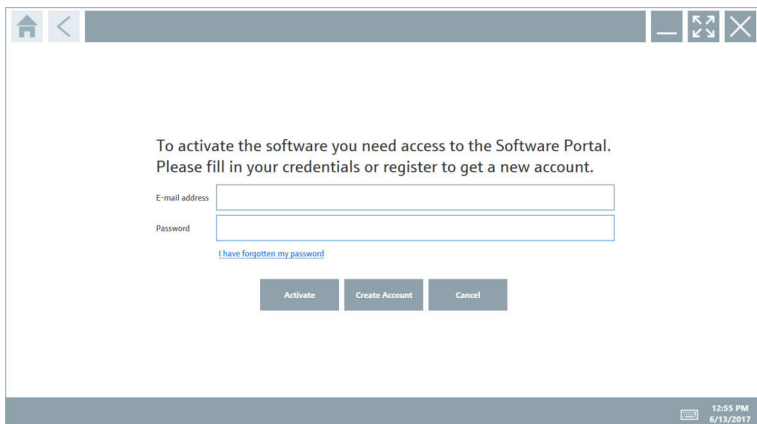

3. Enter the **e-mail address** and **password** and click **Activate**.
  - ↳ The dialog box opens containing the message "The application has been activated successfully".
4. Click **Show license**.
  - ↳ The dialog box with the licensing information opens.
5. Click **Close**.

The home screen of the device configuration software program opens.

## 4 Incoming acceptance and product identification

### 4.1 Incoming acceptance

Visual inspection

- Check the packaging for visible damage arising from transportation
- Open the packaging carefully
- Check the contents for visible damage
- Check that the delivery is complete and nothing is missing
- Retain all the accompanying documents



The device may not be put into operation if the contents are found to be damaged beforehand. In this case, please contact your Endress+Hauser Sales Center:

[www.addresses.endress.com](http://www.addresses.endress.com)

Return the device to Endress+Hauser in the original packaging where possible.

Scope of delivery

- Field Xpert SMT70 tablet PC with handle
- AC charger (100 to 240 V<sub>AC</sub>, 1.5 A, 50 to 60 Hz) with EU connecting cable and international adapter set for 150 countries with country-specific connecting cable
- Software and interfaces/modem as per order
- Operating Instructions with safety instructions from Ecom

## 4.2 Product identification

### 4.2.1 Nameplate

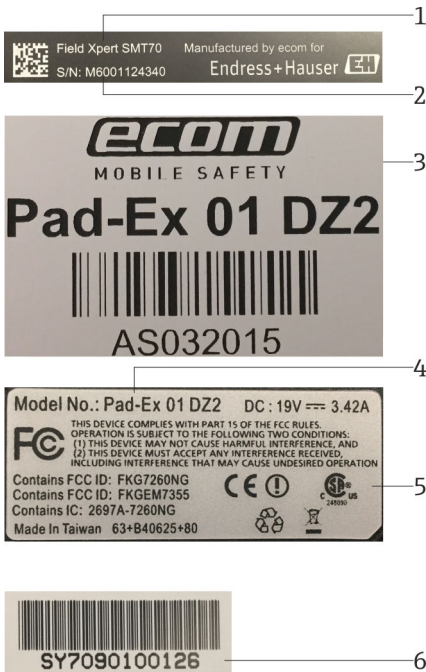

- 1 *Endress+Hauser product name*
- 2 *Endress+Hauser serial number*
- 3 *Manufacturer nameplate*
- 4 *Manufacturer model number*
- 5 *Manufacturer technical information*
- 6 *Manufacturer serial number*

### 4.2.2 Manufacturer address



Ecom Instruments GmbH, D-97959 Assamstadt, Germany is responsible for the tablet hardware and produces it exclusively for Endress+Hauser.

Endress+Hauser Process Solutions AG

Christoph Merian-Ring 12

CH-4153 Reinach

Switzerland

[www.endress.com](http://www.endress.com)

## 4.3 Storage and transport

 Always use the original packaging when transporting the product.

### 4.3.1 Storage temperature

-20 to 60 °C (-4 to 140 °F)



## 5 Installation

### 5.1 System requirements

 The software is already installed on the tablet PC upon delivery.

### 5.2 Installing the software

The device configuration software is already installed on the tablet PC upon delivery. The device configuration software must be activated.

 Licensing model →  13

### 5.3 Updating the software

1. Click the  icon on the home screen of the device configuration software.
  - ↳ The dialog box with the licensing information opens.

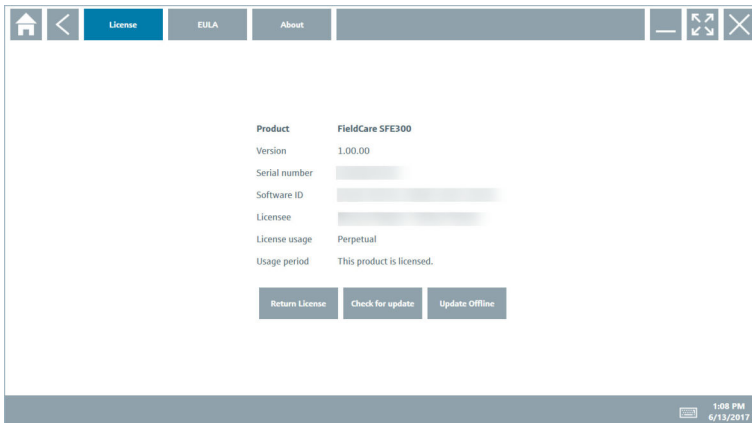

2. Click **Check for updates**.
  - ↳ The device configuration software searches for updates.



## 5.4 Removing the software



The device configuration software may not be uninstalled.

# 6 Software operation

Avoid damage to the housing and components:

- ▶ Always place the device on a stable surface.
- ▶ Do not cover the ventilation opening, or block it by other objects.
- ▶ Keep the device away from liquids.
- ▶ Do not expose the device to direct sunshine or very dusty conditions.
- ▶ Do not expose the device to excess heat or humidity.

## 6.1 Status indicators

The status indicators on the interface of the tablet PC are lit as soon as the corresponding functions are active.

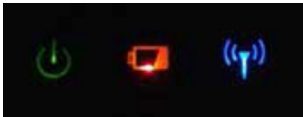

4 Status indicator

Symbol	Meaning	Description
	Power	The LED is lit green when the system is in operation. The LED flashes when the system is in sleep mode.
	Wireless communication	Indicates the status of wireless communication (WLAN, WWAN or Bluetooth). The LED is lit blue if at least one wireless communication option is active. The "Quick Menu" application must be installed to be able to display the status for wireless communication.
	Battery	Indicates the battery charge state: <ul style="list-style-type: none"> <li>▪ Green, battery is fully charged</li> <li>▪ Amber, battery is charging</li> <li>▪ Flashing amber, error while charging</li> <li>▪ Red, battery less than 10 % charged</li> <li>▪ Off, battery is empty</li> </ul>

## 6.2 Shutting down the tablet PC



Make sure you shut down the tablet PC properly, as this is the only way to avoid losing unsaved data.

- ▶ Tap the **Windows icon** → → **Shut down**.

The tablet PC shuts down.



**i** Do not disconnect the power source until the tablet PC is switched off completely.



### 6.3 Switching off the tablet PC

► Press and hold the  button until the power LED flashes.

The tablet PC is in sleep mode.

### 6.4 Security screen

**i** If the tablet PC is used without an external keyboard, the key combination Ctrl+Alt+Del is replaced by the key combination of simultaneously pressing the  and  keys.

1. Press the  and  keys simultaneously.
  - ↳ The tablet PC switches to the Windows security screen.

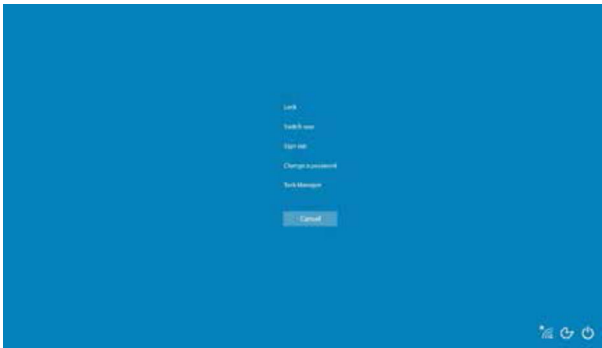

2. Select an action.

Possible actions:

- Lock the device
- Change to another user
- Log out
- Change the password
- Open Task Manager
- Shut down or restart the device

## 7 Commissioning

The tablet PC can be powered by the AC adapter or the lithium ion battery.

## 7.1 Inserting the battery

1.

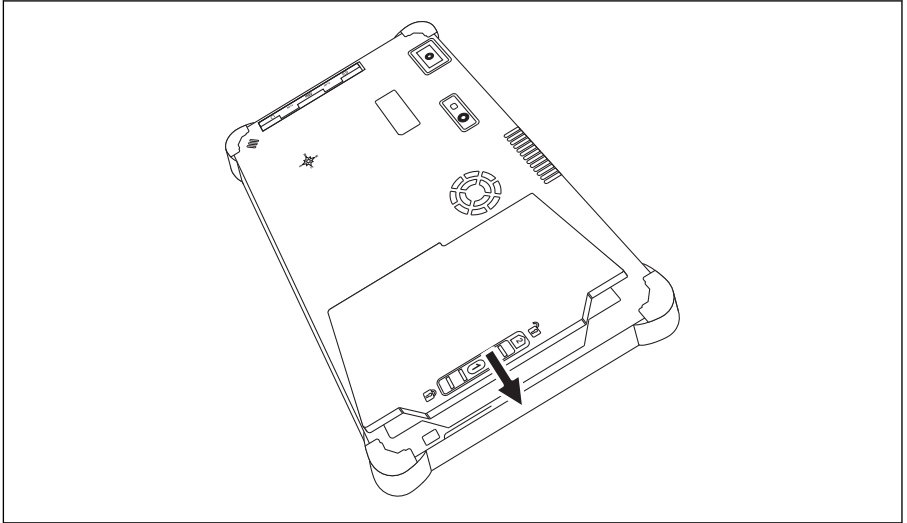

Insert the battery in the battery compartment.

2. Press down until the battery clicks into place.

3.

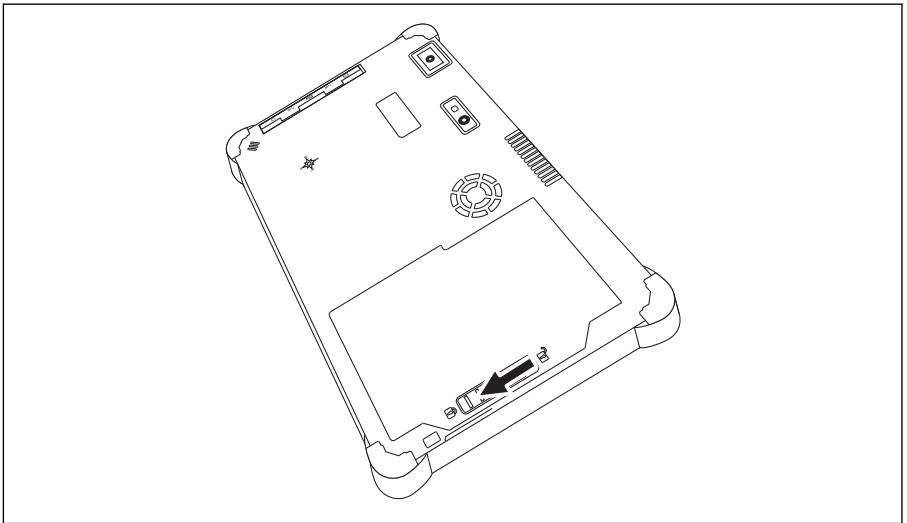

Slide the battery lock into the "Locked" position.

The battery is inserted.

## 7.2 Charging the battery

 Due to transport safety regulations, the lithium ion battery is not fully charged when purchased.

1. The battery must be inserted.  
Connect the AC adapter to the DC socket of the tablet PC.
2. Connect the AC adapter to the power cable.
3. Connect the power cable to a power outlet.

## 7.3 Switching on the tablet PC

► Press and hold the  button until the power LED is lit.

The tablet PC starts.

## 7.4 Connecting the AC adapter

The AC adapter powers the tablet PC and charges the battery.

 When using the AC adapter:

Place the device sufficiently close to a power outlet that the power cable can still reach the outlet.

Only operate the device with the type of power source indicated on the device nameplate.

Disconnect the AC adapter from the power outlet if the device will not be used for an extended period.

1. Connect the AC adapter to the DC socket of the tablet PC.
2. Connect the AC adapter to the power cable.
3. Connect the power cable to a power outlet.

 The tablet PC may only be used with the corresponding AC adapter.

If the tablet PC is connected to a socket and the battery is inserted, the tablet PC is powered via the socket.

# 8 Operation

### NOTICE

**The use of unsuitable objects to operate the device** can damage the screen.

► Do not use pointed objects for the screen.

## 8.1 How to start



The user must accept the terms of use the first time the device configuration software is started.



- ▶ Double-click **Field Xpert SMT70** on the start screen.
  - ↳ The device configuration software starts.

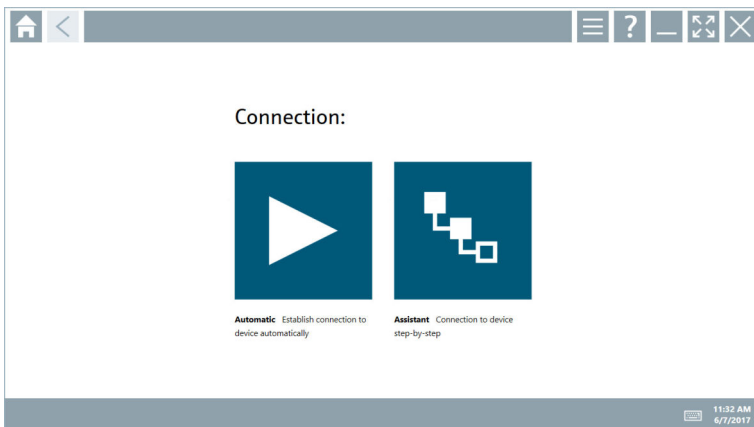



















## 8.2 Establishing a connection to the device















A connection can be established in either of two ways:

- Automatically
- Using a wizard (manually)

Connect the desired modem or interface. Wait until the modem or interface has been detected (e.g. USB icon).

*The following modems/interfaces are supported by the tablet PC:*

Communication protocol	Connection	Modems/interfaces
HART		Endress+Hauser Commubox FXA195 4 to 20 mA
		
		MACTek Bluetooth modem 4 to 20 mA
		Memograph RSG45 (4 to 20 mA)
		
		MACTek USB modem (4 to 20 mA)
		
		Softing Mobilink
		
	Fieldgate SFG250	
	Tank Scanner NXA820	
HART via PROFINET		Fieldgate PAM SFG600
PROFIBUS		Softing PROFibus
		Softing PBpro USB
		Fieldgate SFG500
FOUNDATION Fieldbus		NI USB
		Softing Mobilink
		Softing FFusb

Communication protocol	Connection	Modems/interfaces
Modbus		Modbus serial
WirelessHART		WirelessHART adapter SWA70
		WirelessHART Fieldgate SWG70
Endress+Hauser service interfaces		Commubox FXA291 CDI
		
		Commubox FXA291 IPC, ISS, PCP
		Commubox FXA193 IPC, ISS
		TXU10 V2 CDI
		TXU10 V2 PCP
		
		TXU10 V1 PCP, CDI
		CDI USB
		
		CDI TCP/IP

## "Automatic" connection

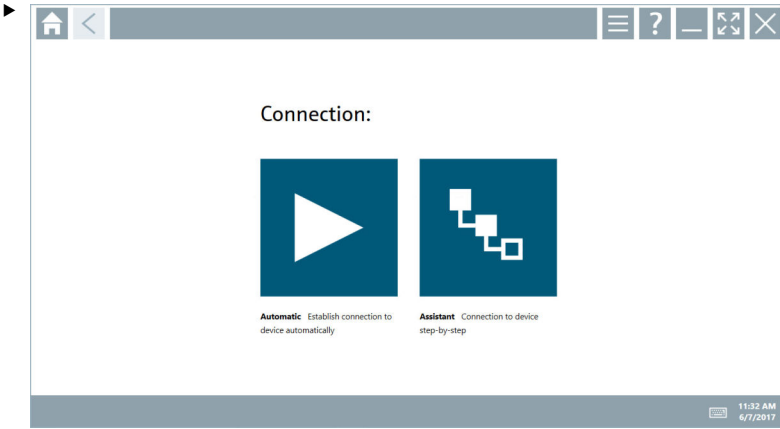

Click the ▶ icon.

↳ The device configuration software establishes a connection to the connected device.



## "Wizard" connection

1.



Click the  icon.

↳ An overview of all the protocols available opens.

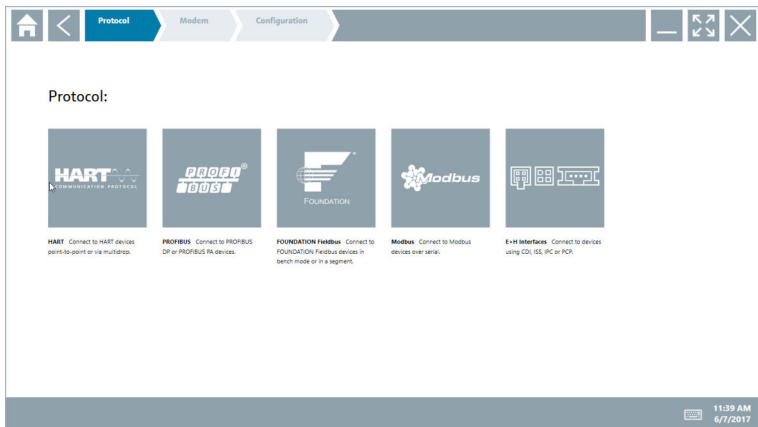

2. Select a communication protocol.
  - ↳ An overview of all the modems available opens.

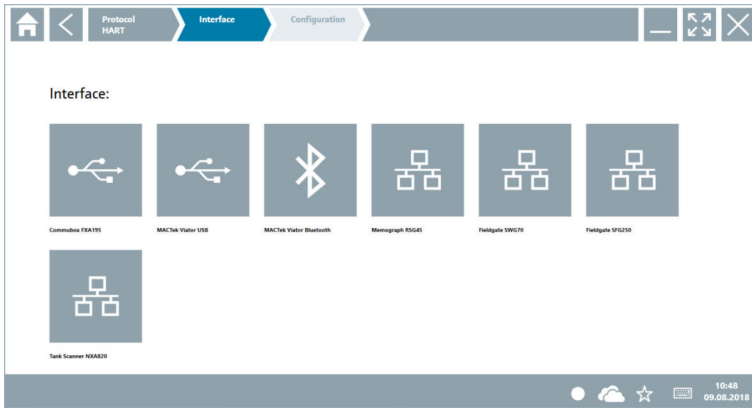

3. Select a modem.
  - ↳ The device can now be configured.

## 8.3 Information and software settings

- ▶ Click the  icon in the main menu.
  - ↳ The overview of all the information and settings opens.

### 8.3.1 DTM catalog

- ▶ Click the **DTM catalog** tab.
  - ↳ The overview of all the DTMs available opens.

Icon	DTM Device Type	Version	Manufacturer	Date	Protocol
	_DD-MIO-Ex12-FF Rev 1	DD Rev 0x1	PyperIn/Julius GmbH (DTM)	2017-01-03	FieldBus FF H1
	0000C0D04 Name not available Rev 1	DD Rev 0x1	Manufacturer Expansion (DTM)	2018-06-30	HART
	0000010D04 Name not available Rev 1	DD Rev 0x1	Power-Genex Ltd. (DTM)	2018-06-30	HART
	0990 Fieldbus Switch Box Rev 4	DD Rev 0x1	EL-O-MATIC BV (DTM)	2000-09-01	FieldBus FF H1
	1000 Rev 3	DD Rev 0x1	ROSEMOUNT ANALYTICAL DIVISION (DTM)	2001-05-09	FieldBus FF H1
	1056 Rev 1	DD Rev 0x1	Rosemount Analytic (DTM)	2018-06-30	HART
	1056 Rev 2	DD Rev 0x1	Rosemount Analytic (DTM)	2018-06-30	HART
	1066 Rev 1	DD Rev 0x1	Rosemount Analytic (DTM)	2018-06-30	HART
	1066 Rev 2	DD Rev 0x1	Rosemount Analytic (DTM)	2018-06-30	HART
	1066-C/F-FF Conductivity Analyzer Rev 1	DD Rev 0x3	ROSEMOUNT ANALYTICAL INC. (DTM)	2011-12-16	FieldBus FF H1
	1066-DO/CL/Q2-FF Amperometric Analyzer Rev 1	DD Rev 0x3	ROSEMOUNT ANALYTICAL INC. (DTM)	2012-01-18	FieldBus FF H1
	1066-P-FF Fieldbus Transmitter Rev 1	DD Rev 0x5	ROSEMOUNT ANALYTICAL INC. (DTM)	2010-12-21	FieldBus FF H1
Total: 2972					

### Device driver offline view

- ▶ Double-click the desired device driver.

The offline view of the device driver opens.



This function is only possible if the device driver supports the offline view.



If other device drivers (DTMs) are required, they can be installed additionally. After an automatic or manual  update, these drivers appear in the DTM catalog.

### 8.3.2 Event log

- ▶ Click the **Event log** tab.
  - ↳ The overview of all the events opens.

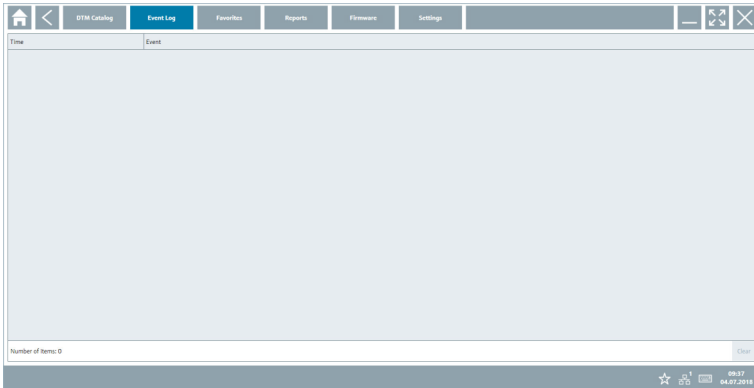

If event logs are already listed, they can be deleted using the **Delete** button.

### 8.3.3 Favorites

- ▶ Click the **Favorites** tab.
  - ↳ The overview of all the favorites opens.

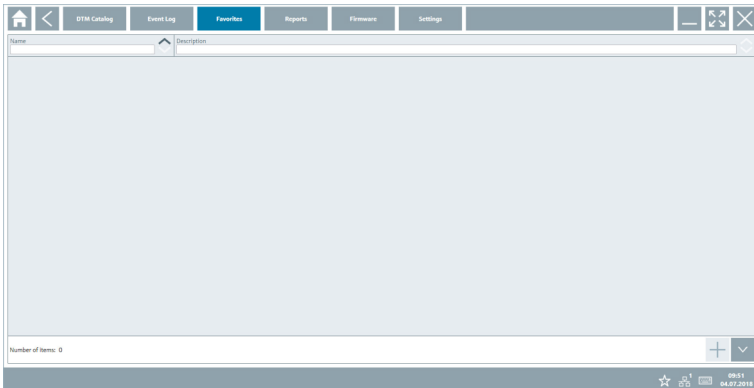

### 8.3.4 Managing reports

1. Click the **Manage reports** tab.

↳ The overview with the "Managed saved device reports" folder opens.

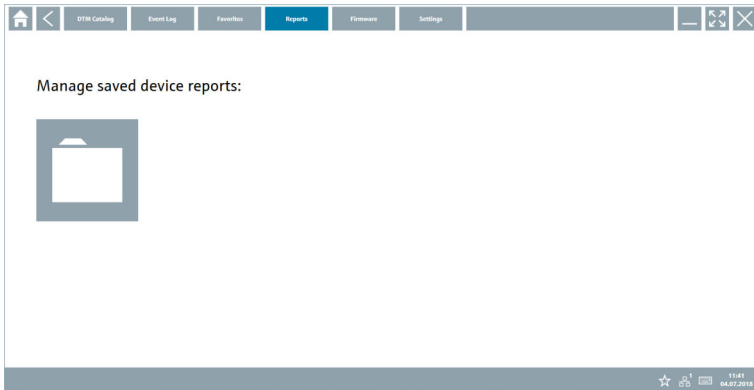

2. Click the "Managed saved device reports" folder.

↳ The overview of all the saved device reports opens.

### 8.3.5 Firmware

▶ Click the **Firmware** tab.

↳ The overview of the firmware opens.

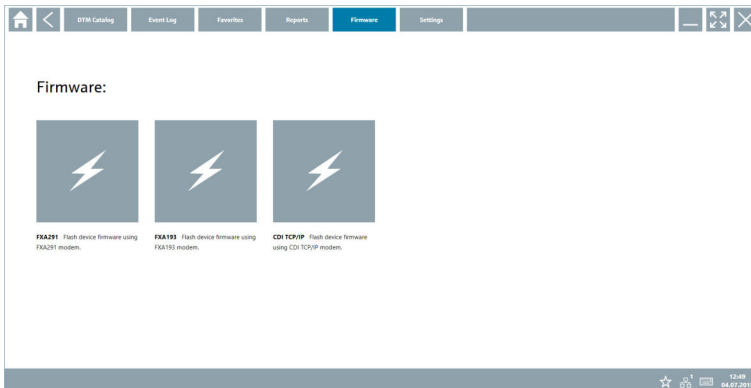

## 8.3.6 Settings

### Language

1. Click the **Settings** tab.
  - ↳ The **Language** tab with an overview of all the languages available opens.



2. Click the desired **language**.
3. Click the  icon.
  - ↳ The device configuration software closes.
4. Restart the device configuration software.
  - ↳ The selected language is saved.

### Connection

- ▶ Click the **Connection** tab.
  - ↳ The overview of all the connections opens.

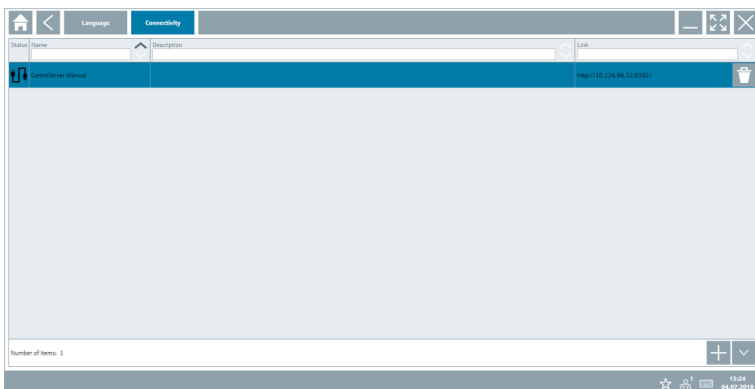

## 8.4 Additional information about the software

- ▶ Click the  icon.
  - ↳ The overview of all the additional information opens.

### 8.4.1 License

- ▶ Click the **License** tab.
  - ↳ The dialog box with the licensing information opens.

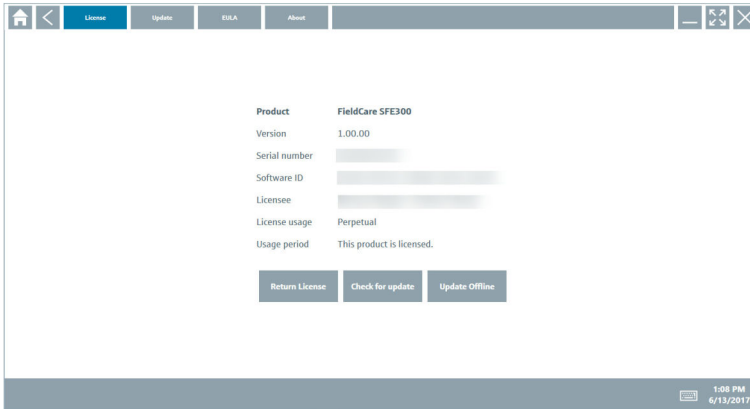

### 8.4.2 Update

- ▶ Click the **Update** tab.
  - ↳ The window with the updates opens.

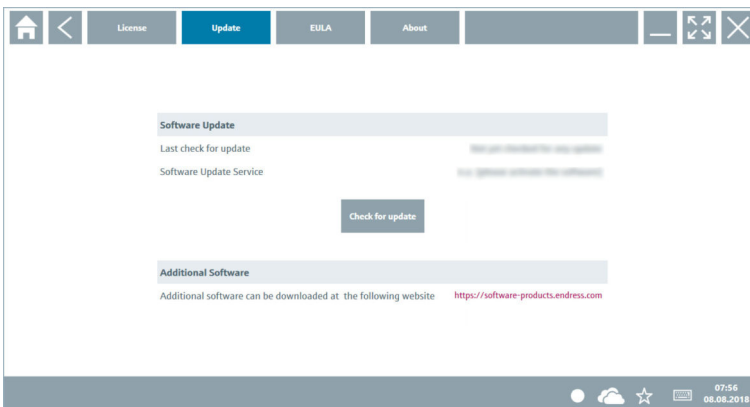

### 8.4.3 EULA

- ▶ Click the **EULA** tab.
- ↳ The window with the Endress+Hauser Terms and Licensing Conditions opens.

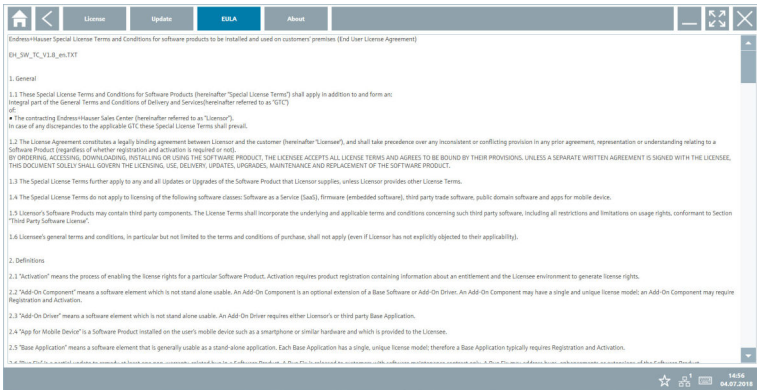

### 8.4.4 About

This tab contains information about the software currently installed, the manufacturer and the software source text.

1. Click the **About** tab.

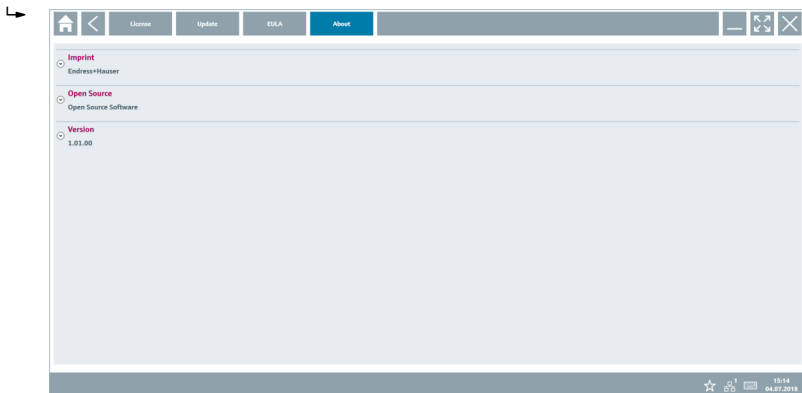



The overview with the information opens.

2. Click the  icon to view the information.

## 8.5 Fieldgate PAM SFG600 HART via PROFINET

The Fieldgate PAM SFG600 is a device configuration management gateway and supports HART devices via PROFINET networks. The HART devices must have a unique device TAG. Also, the devices must be in operation with a PROFINET controller and operated via the

Siemens assembly ET200SP IM 155-6PN HF with the 4x1 2-wire HART analog modules with HART capabilities.

 For detailed information on "Fieldgate PAM SFG600", see the Brief Operating Instructions →  6





Click the  icon.

↳ The **Communication server** overview opens.

## 9 Diagnostics and troubleshooting

### 9.1 General troubleshooting

Problem	Corrective action
The device configuration software has been uninstalled.	<p>The device configuration software must be reinstalled: This PC\Local disk (C:)\Restore\Field Xpert SMT70\FieldCareSFE300Setup.exe</p> <p> The device configuration software can only be reinstalled if it is activated and the service period of one year (starting with the activation of the software) has not yet expired.</p>

 Important support information can be compiled using the key combination Ctrl-Shift-S. This information can then be saved in a zip file (FieldCareSFE300\_SupportFiles.zip) on the Windows desktop.



## 10 Maintenance

### 10.1 Replacing the battery



**Incorrect replacement of the battery** can cause an explosion.

- ▶ Always replace the battery with an identical battery or an equivalent type of battery recommended by the manufacturer.



The battery capacity gradually diminishes over time, depending on how the battery is used. The battery can be replaced after 18 to 24 months.

Dispose of used batteries in accordance with the manufacturer's instructions.

#### Removing the battery

1.

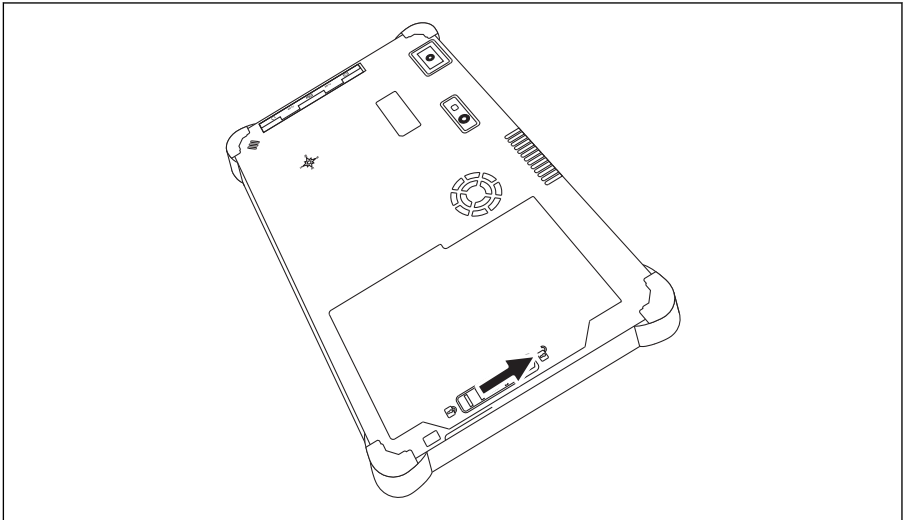

Slide the battery lock into the "Unlocked" position.

2.

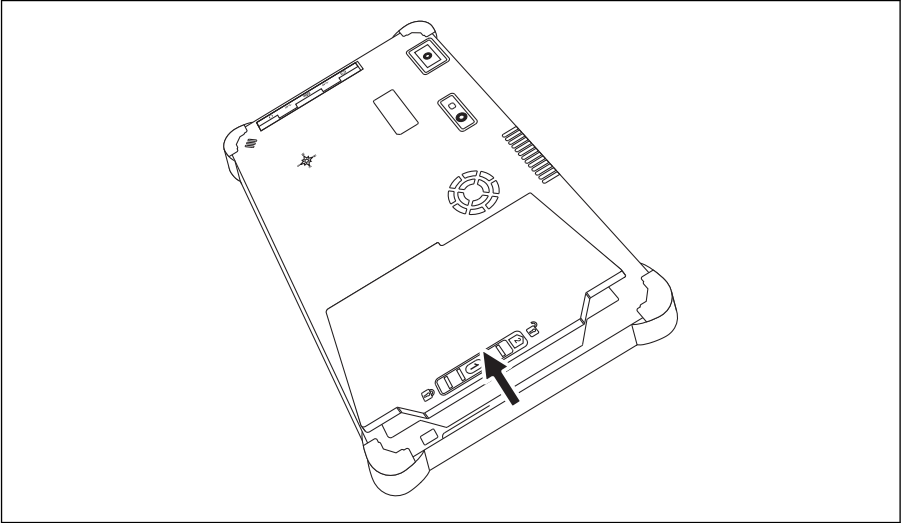

Open the battery compartment and remove the battery.

**i** For information on inserting the battery →  19

## 10.2 Cleaning

**i** When cleaning the device:

Switch off the device correctly and disconnect the AC adapter.

Wipe the device with a clean, dry cloth.

Never use abrasive cleaning agents to clean the device.

# 11 Repair

## 11.1 General notes

### NOTICE

**Never disassemble or repair the device yourself,**  
as this will render the warranty invalid.

- ▶ If the device is in need of repair, always contact your Endress+Hauser Sales Center:  
[www.addresses.endress.com](http://www.addresses.endress.com)

## 11.2 Spare parts

Detailed information about spare parts is available from the Endress+Hauser Sales Center:  
[www.addresses.endress.com](http://www.addresses.endress.com) or at [www.endress.com/smt70](http://www.endress.com/smt70)

## 11.3 Return

The device must be returned if the wrong device has been ordered or delivered, or if the device is in need of repair. As an ISO-certified company and also due to legal regulations, Endress+Hauser is obliged to follow certain procedures when handling any returned products.

To ensure safe, swift and professional device returns, please refer to the procedure and conditions for returning devices provided on the Endress+Hauser website

<http://www.endress.com/support/return-material>

## 11.4 Disposal

When disposing of consumables and waste material, follow the current regulations for waste disposal.

The tablet PC can be handed in directly to the place of purchase free of charge, where it will be disposed of in an environmentally friendly manner on your behalf.

### 11.4.1 Battery disposal

This product contains a lithium-ion battery or a nickel-metal hydride battery. These batteries must be disposed of in the correct manner. Please contact your local environmental protection authority for information on recycling and disposal schemes in your country.

## 12 Accessories

Optional accessories:

- X-strap
- Shoulder strap
- Leather case
- Office docking station (2 x USB 3.0, 2 x USB 2.0, 1 x RS232, HDMI, 1 Gbit Ethernet)
- Vehicle docking station with vehicle adapter (2 x USB 3.0, 2 x USB 2.0, 1 x RS232, HDMI, 1 Gbit Ethernet, WWAN + GPS antenna connection)
- Extra battery, high-capacity 7 800 mAh
- Extra battery, standard capacity 4 100 mAh
- Battery charger

Please contact your Endress+Hauser sales center for detailed information on accessories:

[www.addresses.endress.com](http://www.addresses.endress.com) or at [www.endress.com/smt70](http://www.endress.com/smt70)

## 13 Technical data



For detailed information on the "technical data": see the Technical Information →  6

## 14 Appendix

### 14.1 Federal Communication Commission (FCC)

This device has been tested and complies with the limit values for Class B digital devices in accordance with Part 15 of the FCC regulations. These limit values ensure adequate protection against electromagnetic interference when operating in residential areas. This device generates, uses and can emit radio frequency energy and can interfere with wireless communication if it is not installed and used as specified in the Operating Instructions. However, it is not possible to guarantee that interference will not occur in certain installations. If the device causes interference with radio and television reception - which can be determined by switching the device off and on again - it is the responsibility of the user to rectify the problem → 📖 32.

### 14.2 Canada, Industry Canada (IC) Notices / Canada, avis d'Industry Canada (IC)

This Class B digital apparatus complies with Canadian ICES-003 and RSS-210. Operation is subject to the following two conditions: (1) this device may not cause interference, and (2) this device must accept any interference, including interference that may cause undesired operation of the device.

Cet appareil numérique de classe B est conforme aux normes canadiennes ICES- 003 et RSS-210. Son fonctionnement est soumis aux deux conditions suivantes : (1) cet appareil ne doit pas causer d'interférence et (2) cet appareil doit accepter toute interférence, notamment les interférences qui peuvent affecter son fonctionnement.

#### 14.2.1 Radio Frequency (RF) Exposure Information

The radiated output power of the Wireless Device is below the Industry Canada (IC) radio frequency exposure limits. The Wireless Device should be used in such a manner such that the potential for human contact during normal operation is minimized. This device has been evaluated for and shown compliant with the IC Specific Absorption Rate ("SAR") limits when installed in specific host products operated in portable exposure conditions.

Informations concernant l'exposition aux fréquences radio (RF) La puissance de sortie émise par l'appareil de sans fil est inférieure à la limite d'exposition aux fréquences radio d'Industry Canada (IC). Utilisez l'appareil de sans fil de façon à minimiser les contacts humains lors du fonctionnement normal. Ce périphérique a été évalué et démontré conforme aux limites SAR (Specific Absorption Rate – Taux d'absorption spécifique) d'IC lorsqu'il est installé dans des produits hôtes particuliers qui fonctionnent dans des conditions d'exposition à des appareils portables.

### 14.3 Warning Explosion Hazard

#### Class I, Division 2, Groups A, B, C, D, T Code T5

Model R11XXXXXX, Rugged Tablet PC, Battery Powered (Battery P/N R11AH or R11AH2XXXXXX rechargeable lithium-ion battery pack), Ambient Temperature Range: 0°C to +40°C. Note: The "X" in the model designations may be any alphanumeric character or blank

denoting minor mechanical options, system configuration options and/or safety extra low voltage secondary circuit options.

**Conditions of Safe Use:**

Connection to or from this device, which enters or leaves the system enclosure, must be completely restricted in Class I, Division 2 Hazardous Locations.

Rugged Tablet PC is to be charged by the supplied charging adaptor, type FSP065-RAB, manufactured by FSP Group, in Non-Hazardous Location only.

Suitable for use in Class I, Division 2 Groups A, B, C and D hazardous locations or non-hazardous locations only;

“WARNING - EXPLOSION HAZARD - SUBSTITUTION OF COMPONENTS MAY IMPAIR SUITABILITY FOR CLASS I, DIVISION 2.”

AVERTISSEMENT - RISQUE D'EXPLOSION - LA SUBSTITUTION D E COMPOSANTSP EUTR ENDRE CE MATERIEL INACCEPTABLE POUR LES EMPLACEMENTS DE CLASSE I, DIVISION 2.

“WARNING: TO PREVENT IGNITION OF A HAZARDOUS ATMOSPHERE, BATTERIES MUST ONLY BE CHARGED IN AN AREA KNOWN TO BE NON- HAZARDOUS.”

“AVERTISSEMENT- RISQUE D'EXPLOSION- AFIN D'EVITER TOUT RISQUE D'EXPLOSION, S'ASSURER QUE L'EMPLACEMENT EST DESIGNE NON DANGEREUX AVANT DE CHANGER LA BATTERIE.”

“WARNING - EXPLOSION HAZARD - DO NOT CONNECT OR DISCONNECT WHILE CIRCUIT IS LIVE UNLESS AREA IS KNOWN TO BE NON- HAZARDOUS.”

“AVERTISSEMENT - RISQUE D'EXPLOSION. NE PAS BRANCHER OU DÉBRANCHER TANT QUE LE CIRCUIT EST SOUS TENSION, À MOINS QU'IL NE S'AGISSE D'UN EMPLACEMENT NON DANGEREUX.”

## 14.4 Class 1 laser product

### Class 1 laser product in accordance with EN 60825

This device contains a laser system and is categorized as a "Class 1 laser product". To use this device correctly, you must read this manual carefully and keep it in a safe place so that it is also available for future reference. If you encounter any problems with this model, please contact your nearest "Authorized service point". To avoid direct laser radiation, do not attempt to open this housing.





[www.addresses.endress.com](http://www.addresses.endress.com)

---