

SL17 Submersible Pressure Transmitter



APPLICATIONS

Because of its small 17mm diameter and rugged 316L SS construction, the Ashcroft SL17 submersible pressure transmitter is ideal for level applications, particularly in situations where size or chemical compatibilities are an issue. The SL17 utilizes piezo-resistive technology (PRT) that is known for its proven reliability and stability. Notably, these transmitters can offer all ranges equivalent from 1.5 psig through 300 psig while all units of measure and cable lengths are customer-defined for individualized specifications.

FEATURES

- Complete 316L SS Construction
- IP68 / NEMA 6P Housing
- Excellent Long-Term Stability
- 4-20 mA Output (2-wire)
- Unit of Measure Selection (Psig, Feet or Meters of H₂O)
- Optional NIST Traceable Calibration Chart (9-point)

TYPICAL APPLICATIONS

- Level (Groundwater / Bore)
- Wastewater
- Tank Level Measurement

PERFORMANCE SPECIFICATIONS

Reference Condition: 21°C (70°F)

Humidity: 0-100%RH*

Accuracy: ±0.25% of span, terminal point (>5 psi);
 ±0.5% of span, terminal point (<5 psi);
 Includes effects of linearity, hysteresis and repeatability

Stability: ±0.25% FS/year

Engineering Units: psi, bar, ftH₂O, mH₂O and customer defined

Ranges: 1.5-300 psi & equivalent (see table); gauge pressure only

*Based on cable vented to clean, dry, non-corrosive atmosphere or proper use of termination desiccant box

ENVIRONMENTAL SPECIFICATIONS

Temperature Limits†

Compensated: -10/40°C (14/104°F)

Operating: -10/40°C (14/104°F)

Storage: -20/60°C (14/140°F)

Temperature Effects (-10 to 40°C): ±1% TEB
 (>5 psi) ±1.5% span, terminal point (<5 psi)

† For non-frozen liquid applications only

FUNCTIONAL SPECIFICATIONS*

Overpressure (FS):	Proof	Burst
1.5-5 psi	300%	500%
10 psi	300%	750%
15-30 psi	200%	500%
75 psi	187%	470%
150 psi	200%	400%
300 psi	200%	300%

Maximum Turndown: 2:1 from original sensor pressure range

Vibration & Shock: IEC 60068-2-6

*Based on sensor range

ELECTRICAL SPECIFICATIONS

Output Signal: 4-20mA (2 wire)

Supply Voltage: 10-36Vdc

Insulation Resistance: 50Vdc (100Mohm)

Withstand Voltage: 350Vdc

CE Compliance:

- EMI Class A/EMS Table 2 EN61326-1:2006
- Annex BB (Pressure Transducer)
 EN61326-2-3:2007
- ESD EN61000-4-2
- Burst EN61000-4-4
- Surge EN61000-4-5

MECHANICAL SPECIFICATIONS

Pressure Connection: M14 × 1.5

Weight: Sensor (120g)

Nose Cones: standard (13g), weighted (225g)

Enclosure: 316L SS

Labels: Laser-etched with customer part number

Cable External Jacket: Coated (.03") black polyurethane

Cable Internal Construction: 4-wire 22 AWG conductors (red, black, green, white)

Vent tube: 0.060" ID polyethylene

Semi-rigid PVC with shield and Kevlar strength member

Cable Pull Strength: 180 lb

Cable Voltage Rating: 300V

Load Limitation: 4-20mA Output Only

Wetted Materials: 316L SS and polyurethane



LOOK FOR THIS
 AGENCY

Model SL17 Submersible Transducer

Dimensions

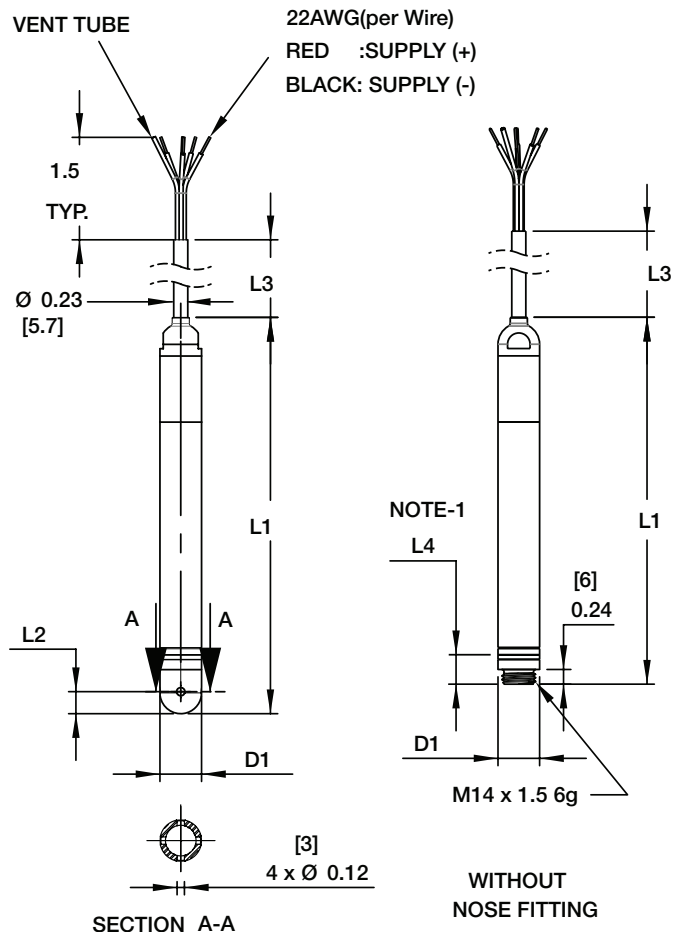

DIMENSIONS, Inches (Millimeter)					
NOSE FITTING	D1	L1	L2	L2	L4
Without Nose Cone	0.67 (17)	5.90 (150)	N/A		0.47 (12)
(SNC) Standard Nose Cone	0.67 (17)	6.37 (162)	0.35 (9)	Per Order	0.94 (24)
(P5C) 0.5LBS Nose Cone	0.67 (17)	10.98 (279)	4.96 (126)		5.55 (141)

How To Order

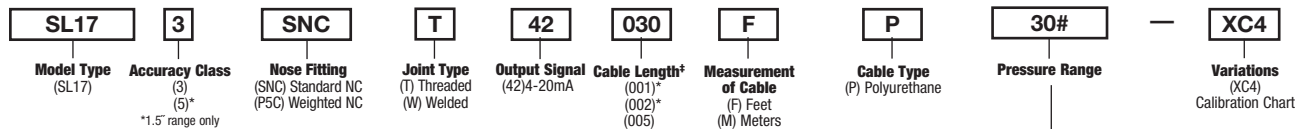

psi	Ft H ₂ O	Mt H ₂ O	Bar
(1P5#) 1.5	(10FW) 10' H ₂ O	(5LW) 5 m H ₂ O	(0.6BR) 0.6 Bar
(5#) 5	(20FW) 20' H ₂ O	(10LW) 10 m H ₂ O	(1BR) 1 Bar
(10#) 10	(30FW) 30' H ₂ O	(15LW) 15 m H ₂ O	(1.6BR) 1.6 Bar
(15#) 15	(50FW) 50' H ₂ O	(20LW) 20 m H ₂ O	(2.5BR) 2.5 Bar
(20#) 20	(100FW) 100' H ₂ O	(30LW) 30 m H ₂ O	(4BR) 4 Bar
(30#) 30	(150FW) 150' H ₂ O	(50LW) 50 m H ₂ O	(6BR) 6 Bar
(50#) 50	(200FW) 200' H ₂ O	(75LW) 75 m H ₂ O	(10BR) 10 Bar
(75#) 75	(300FW) 300' H ₂ O	(100LW) 100 m H ₂ O	
(100#) 100	(400FW) 400' H ₂ O	(125LW) 150 m H ₂ O	
(150#) 150	(500FW) 500' H ₂ O	(150LW) 200 m H ₂ O	
(200#) 200			
(300#) 300			

*Available in meters only
[†] Available in feet only
[‡] Custom cable lengths available, example for 35 feet, code as (035).