



SERIES SA1100 | MERCOID® BY DWYER



DIAPHRAGM OPERATED PRESSURE SWITCHES

Visible Setpoint, Adjustable Deadband, Hermetically Sealed Snap Switch, Weatherproof and Explosion-Proof

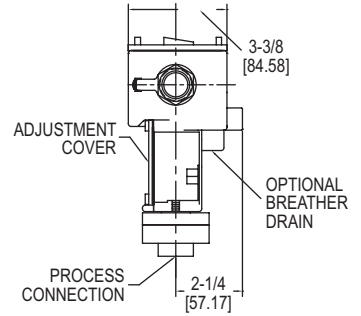
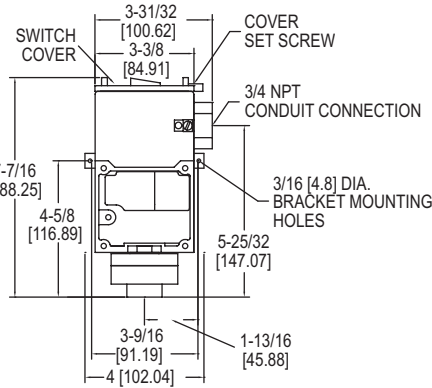
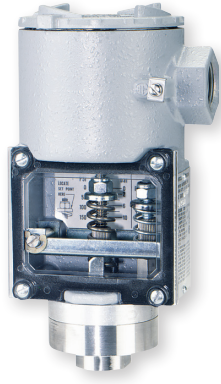

The **SERIES SA1100** Diaphragm Operated Pressure Switches are weatherproof and explosion-proof in one economical enclosure. Extremely rugged construction assures excellent reliability in chemical, petroleum and industrial plants. New design also provides burst pressure protection to 3000 psi (206 bar). The rolling diaphragm design maintains a constant effective area to minimize friction. This results in a minimum deadband as low as 5% of full-scale. Since many applications require higher deadbands, the SA1100 includes a separate adjustment of this when necessary. A pump being used to control liquid level in a tank would be a typical situation where this feature would be important. Both setpoint and deadband adjustments are protected, yet clearly visible behind a clear polycarbonate window and are fully isolated from the electrical components for additional safety. A 7/16" open-end wrench is the only tool required to change settings. Terminal blocks are provided for switch wiring connections and both internal and external ground screws are included. Standard housing is weatherproof to NEMA standards 1 through 4X and 13; explosion-proof to NEMA 7, Class I, Groups B, C & D; NEMA 9, Class II, Groups E, F & G. Optional construction adds drain to meet NEMA 3R IP54.

FEATURES/BENEFITS

- Explosion-proof and weatherproof housing provides device protection for outdoor use or harsh environment operation
- Burst pressure protection prevents device failure where high-pressure surges may damage device costing down-time and repair/replacement
- Adjustable deadband reduces equipment cycling and potential failure
- Visible set-point and deadband adjustments provide an easy and fast check without having to open device causing dangerous conditions to operators

APPLICATIONS

- Chemical, petroleum, food and drug processing industries
- Used indoor, outdoor or in explosion-proof area
- Pump control

SPECIFICATIONS

<p>Wetted Materials: See pressure chamber and diaphragm material in model chart.</p> <p>*Temperature Limits: -30 to 180°F (-35 to 82°C) standard; ATEX compliant at Ambient Temperature: -4 to 167°F (-20 to 75°C); Process Temperature: -4 to 167°F (-20 to 75°C).</p> <p>Pressure Limit: 1200 psig (82.6 bar).</p> <p>*Enclosure Rating: Weatherproof and Explosion-proof. Listed with UL and CSA for Class I, Groups B, C and D; Class II Groups E, F, and G. ATEX Compliant CE 0344 Ex II 2 G EEx d IIC T6 Process Temperature 75°C. Weatherproof UL Rated Type 4. Meets NEMA 4X (IP66).</p> <p>*Options that do not have ATEX</p>	<p>Switch Type: SPDT or DPDT snap switch.</p> <p>Electrical Rating: See model chart.</p> <p>Electrical Connections: Screw terminal.</p> <p>Conduit Connection: 3/4" female NPT.</p> <p>Process Connection: 1/2" female NPT.</p> <p>Mounting Orientation: Within 20° of vertical.</p> <p>Set Point Adjustment: Internal 7/16" hex nuts.</p> <p>Weight: 3.5 lb (1.6 kg).</p> <p>Deadband: See deadband chart.</p> <p>*Agency Approvals: ATEX, CE, CSA, UL.</p>
--	--

SWITCH DEADBAND CHART

Range Number	Adjustable Operating Range		Approximate Minimum Deadband				Approximate Maximum Deadband	
	psig	bar	psig	bar	psig	bar	psig	bar
11	10-150	0.7-10	4.0	0.28	7.5	0.52	75	5.2
12	20-250	1.4-17.2	5.0	0.35	12.5	0.86	150	10
13	30-500	2.0-34	12	0.83	45	3.1	300	21

MODEL CHART

Example	SA11	13	E	-A	4	-K	2		SA1113E-A4-K2
Construction	SA11								Series designator, weatherproof NEMA 4X, explosion-proof NEMA 7, 9
Adjustable Pressure Ranges		11							Adjustable range 10 to 150 psig (0.7-10 bar)
		12							Adjustable range 20 to 250 psig (1.4-17.2 bar)
		13							Adjustable range 30 to 500 psig (2.0-34.0 bar)
Circuit (Switch) Options			E						Snap action switch rated 15 A @ 125/250/480 VAC, 1/8 HP @ 125 VAC, 1/4 HP @ 250 VAC, 1/2 A @ 125 VDC resistive, 1/4 A @ 250 VDC resistive
			HS						Hermetically sealed snap action switch rated 5 A @ 125/250 VAC, 5 A resistive @ 30 VDC*
			HG						Hermetically sealed snap action switch with gold contacts rated 1A @ 125 VAC, 1 A resistive @ 30 VDC*
Pressure Chamber Material (Wetted)				A					Aluminum
Diaphragm Material (Wetted)				S					316 SS
					4				Buna-N diaphragm and O-ring
					5				Fluorocarbon diaphragm and O-ring
Circuit (Switch) Type						K			SPDT
						L			DPDT (not available with HS or HG switch options)
Process Connection							2		1/2 inch female NPT
*Options								AT	ATEX certified construction
								DRAIN	Housing with drain - allows condensate to be drained from inside enclosure (meets NEMA 3R instead of 4X)

*Options that do not have ATEX

Examples: SA1111E-A4-K2; SA1111E-S5-K2