

Instruction Manual

PN 51-T1056/rev.D

August 2014

Clarity II™ Turbidimeter

Turbidity Measurement System



ESSENTIAL INSTRUCTIONS

READ THIS PAGE BEFORE PROCEEDING!

Your instrument purchase from Rosemount Analytical, Inc. is one of the finest available for your particular application. These instruments have been designed, and tested to meet many national and international standards. Experience indicates that its performance is directly related to the quality of the installation and knowledge of the user in operating and maintaining the instrument. To ensure their continued operation to the design specifications, personnel should read this manual thoroughly before proceeding with installation, commissioning, operation, and maintenance of this instrument. If this equipment is used in a manner not specified by the manufacturer, the protection provided by it against hazards may be impaired.

- Failure to follow the proper instructions may cause any one of the following situations to occur: Loss of life; personal injury; property damage; damage to this instrument; and warranty invalidation.
- Ensure that you have received the correct model and options from your purchase order. Verify that this manual covers your model and options. If not, call 1-800-854-8257 or 949-757-8500 to request correct manual.
- For clarification of instructions, contact your Rosemount representative.
- Follow all warnings, cautions, and instructions marked on and supplied with the product.
- Use only qualified personnel to install, operate, update, program and maintain the product.
- Educate your personnel in the proper installation, operation, and maintenance of the product.
- Install equipment as specified in the Installation section of this manual. Follow appropriate local and national codes. Only connect the product to electrical and pressure sources specified in this manual.
- Use only factory documented components for repair. Tampering or unauthorized substitution of parts and procedures can affect the performance and cause unsafe operation of your process.
- All equipment doors must be closed and protective covers must be in place unless qualified personnel are performing maintenance.



WARNING **RISK OF ELECTRICAL SHOCK**

- Equipment protected throughout by double insulation.
- Installation and servicing of this product may expose personnel to dangerous voltages.
- Main power wired to separate power source must be disconnected before servicing.
- Do not operate or energize instrument with case open!
- Signal wiring connected in this box must be rated at least 240 V.
- Non-metallic cable strain reliefs do not provide grounding between conduit connections! Use grounding type bushings and jumper wires.
- Unused cable conduit entries must be securely sealed by non-flammable closures to provide enclosure integrity in compliance with personal safety and environmental protection requirements. Unused conduit openings must be sealed with NEMA 4X or IP65 conduit plugs to maintain the ingress protection rating (NEMA 4X).
- Electrical installation must be in accordance with the National Electrical Code (ANSI/NFPA-70) and/or any other applicable national or local codes.
- Operate only with front panel fastened and in place.
- Proper use and configuration is the responsibility of the user.

CAUTION

This product generates, uses, and can radiate radio frequency energy and thus can cause radio communication interference. Improper installation, or operation, may increase such interference. As temporarily permitted by regulation, this unit has not been tested for compliance within the limits of Class A computing devices, pursuant to Subpart J of Part 15, of FCC Rules, which are designed to provide reasonable protection against such interference. Operation of this equipment in a residential area may cause interference, in which case the user at his own expense, will be required to take whatever measures may be required to correct the interference.

CAUTION

This product is not intended for use in the light industrial, residential or commercial environments per the instrument's certification to EN50081-2.

Emerson Process Management

2400 Barranca Parkway
Irvine, CA 92606 USA
Tel: (949) 757-8500
Fax: (949) 474-7250

<http://www.rosemountanalytical.com>

QUICK START GUIDE

FOR CLARITY II TURBIDIMETER

1. Refer to Section 2.0 for installation instructions.
2. The sensor cable is pre-wired to a plug that inserts into a receiving socket in the analyzer. The cable also passes through a strain relief fitting. To install the cable...
 - a. Remove the wrenching nut from the strain relief fitting.
 - b. Insert the plug through the hole in the bottom of the enclosure nearest the sensor socket. Seat the fitting in the hole.
 - c. Slide the wrenching nut over the plug and screw it onto the fitting.
 - d. Loosen the cable nut so the cable slides easily.
 - e. Insert the plug into the appropriate receptacle on the circuit board.
 - f. Adjust the cable slack in the enclosure and tighten the cable nut. For wall/pipe mounting, be sure to leave sufficient cable in the enclosure to avoid stress on the cable and connections.
 - g. Plug the cable into the back of the sensor.
 - h. Place the sensor in either the measuring chamber or the calibration cup. **The sensor must be in a dark place when power is first applied to the analyzer.**
3. Make power, alarm, and output connections as shown in section 3.0 wiring.
4. Once connections are secured and verified, apply power to the analyzer.
5. When the analyzer is powered up for the first time **Quick Start** screens appear. Follow the **Quick Start Guide** to enable live readings.
 - a. A blinking field shows the position of the cursor.
 - b. Use the ◀ or ▶ key to move the cursor left or right. Use the ▲ or ▼ key to increase or decrease the value of a digit. Use the ▲ or ▼ key to move the decimal point.
 - c. Press ENTER to store a setting. Press EXIT to leave without storing changes. Pressing EXIT also returns the display to the language selection screen.

IMPORTANT NOTE:

When using EPA/incandescent sensors (PN 8-0108-0002-EPA):

- n DO NOT power up the instrument without the sensor connected
- n DO NOT disconnect and reconnect a sensor while an analyzer is powered

If this is inconvenient or cannot be avoided:

1. Cycle power to the instrument after connecting the sensor or..
2. Perform a Slope Calibration or Standard Calibration routine after connecting the sensor. Following these guide lines will extend the life of the incandescent lamp and avoid premature warnings and faults due to reduced lamp life.

CONTINUED ON THE FOLLOWING PAGE

QUICK START GUIDE

Figure A. QUICK START GUIDE, Model 1056

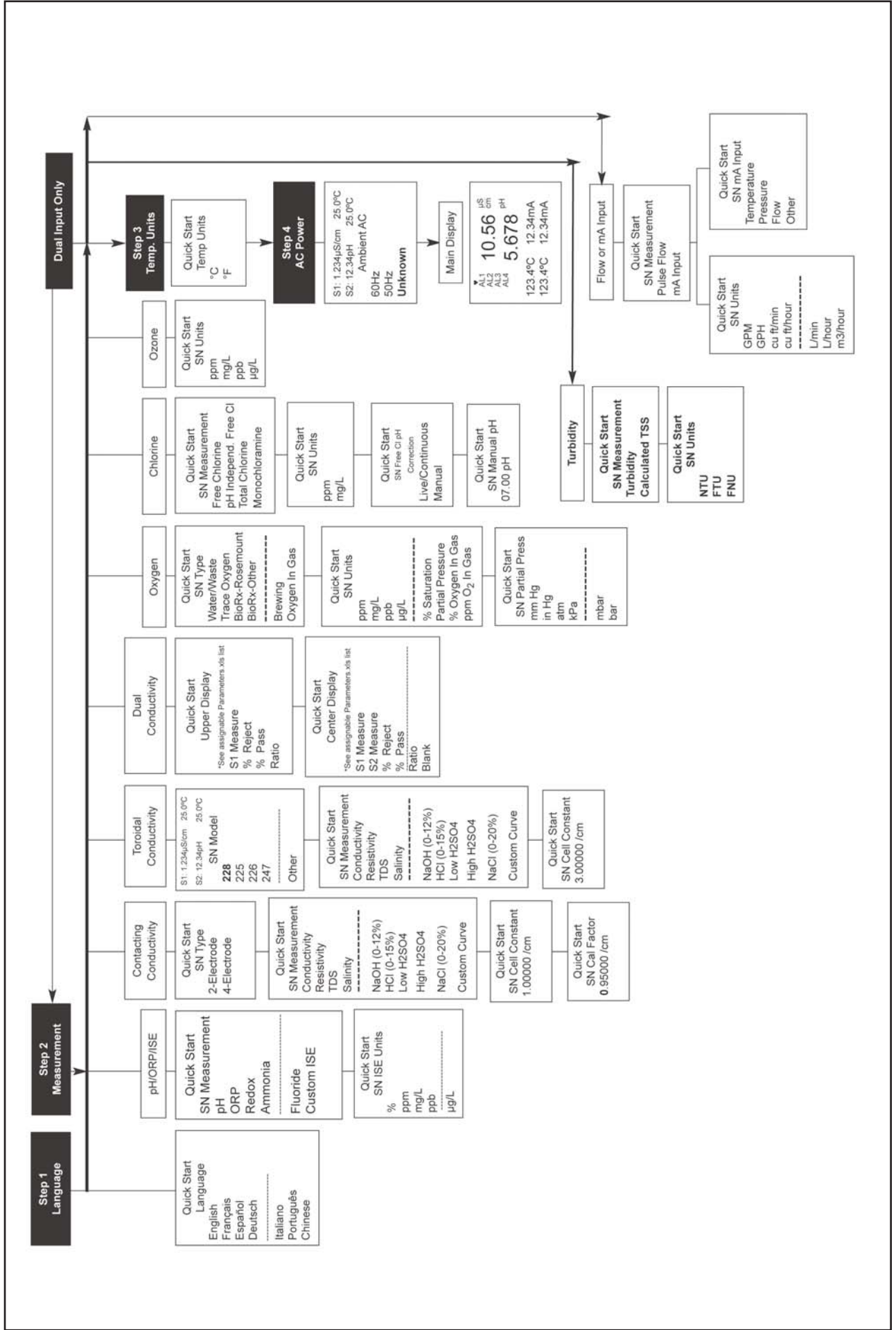

QUICK REFERENCE GUIDE

Figure B. MODEL 1056 MENU TREE

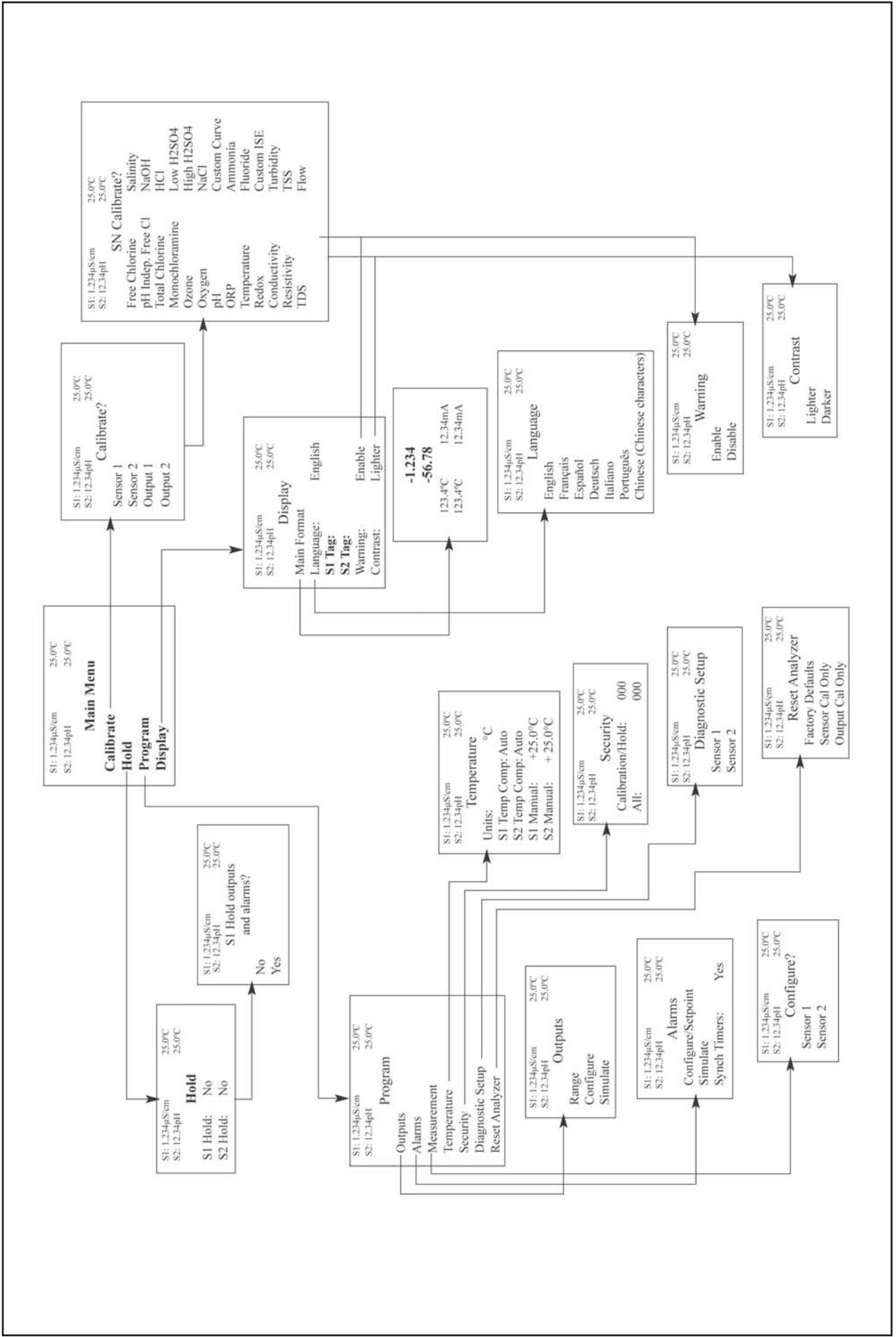

About This Document

This manual contains instructions for installation and operation of the Clarity II Model T1056 Turbidimeter.

The following list provides notes concerning all revisions of this document.

<u>Rev. Level</u>	<u>Date</u>	<u>Notes</u>
A	12/07	This is the initial-launch version.
B	2/09	Update Specifications
C	12/09	Update DNV logo, company name
D	08/14	Change turbidity specifications, add CSA Non-incendive field wiring installation drawings

MODEL CLARITY II TURBIDIMETER

TABLE OF CONTENTS

Section	Title	Page
1.0	DESCRIPTION AND SPECIFICATIONS	1
1.1	Features and Applications	1
1.2	Specifications	2
2.0	INSTALLATION.....	5
2.1	Unpacking and Inspection	5
2.2	Installation	5
2.3	Installation — Debubbler Assembly.....	8
2.4	Installation — Sensor	10
2.5	Sample Point	10
3.0	WIRING	13
3.1	General.....	13
3.2	Preparing Conduit Openings	13
3.3	Preparing Sensor Cable	14
3.4	Power, Output, and Sensor Connections	14
4.0	DISPLAY AND OPERATION	19
4.1	User Interface.....	19
4.2	Instrument Keypad	19
4.3	Main Display.....	20
4.4	Menu System	21
5.0	PROGRAMMING THE ANALYZER.....	23
5.1	General.....	23
5.2	Changing StartUp Settings	23
5.3	Configuring and Ranging the Current Outputs	23
5.4	Setting a Security Code.....	25
5.5	Security Access	26
5.6	Using Hold.....	26
5.7	Resetting Factory Default Settings	27
5.8	Programming Alarm Relays.....	28
6.0	PROGRAMMING TURBIDITY	31
6.1	Programming Measurements - Introduction	31
6.2	Turbidity Measurement Programming	32
6.3	Choosing Turbidity or Total Suspended Solids	35
6.4	Entering a Turbidity to TSS Conversion Equation	38
7.0	CALIBRATION	41
7.1	Calibration Introduction	41
7.2	Turbidity Calibration.....	41
8.0	MAINTENANCE	45
8.1	Model 1056.....	45
8.2	Sensor	46
8.3	Debubbler and Measuring Chamber	47
8.4	List of Replacement Parts	48
9.0	TROUBLESHOOTING.....	49
9.1	Overview	49
9.2	Troubleshooting Using Fault Codes	45
9.3	Troubleshooting Calibration Problems	47
9.4	Troubleshooting Other Problems.....	52
10.0	RETURN OF MATERIAL	55
10.1	General.....	56
10.2	Warranty Repair	57
10.3	NON-Warranty Repair	57

LIST OF FIGURES

Number	Title	Page
2-1	Panel Mount Dimensions	6
2-2	Pipe and Wall Mount Dimensions.....	7
2-3	Debubbler and Flow Chamber	9
2-4	Sensor	10
2-5	Sampling for Turbidity.....	10
2-6	CSA Non-incendive Field Wiring Installation for Turbidity, page 1.....	11
2-7	CSA Non-incendive Field Wiring Installation for Turbidity, page 2.....	12
3-1	24VDC Power Supply.....	14
3-2	Switching AC Power Supply	14
3-3	Current Output Wiring	15
3-4	Alarm Relay Wiring.....	15
3-5	Turbidity Signal Board	16
3-6	Power Wiring for Model 1056 85-265 VAC Power Supply	17
3-7	Power Wiring for Model 1056 24VDC Power Supply	17
3-8	Output Wiring for Model 1056 Main PCB	18
4-1	Formatting the Main Display.....	22
5-2	Configuring and Ranging the Current Outputs	24
5-3	Setting a Security Code.....	25
5-4	Using Hold.....	26
5-5	Resetting Factory Default Settings.....	27
6-1	Converting Turbidity to TSS	33
6-4	Turbidity Sensor — General	35
6-5	Turbidity Sensor — EPA 108.1	35
6-6	Turbidity Sensor — ISO 7027.....	36
6-2	Converting Turbidity to TSS	38
6-2	Lowest Turbidity (TSS).....	38
6-7	Configure Turbidity Measurement	40
7-8	Calibrate Turbidity	44
8-3	Replacing the Lamp/LED Board.....	46
8-4	Molded Buffer Assembly.....	48

LIST OF TABLES

Number	Title	Page
2-1	Approximate Debubbler Pressure as a Function of Flow	8
6-11	Turbidity Measurement Programming	32
7-12	Turbidity Calibration Routines	41
8-1	Replacement Parts for Model 1506.....	45

APPENDIX

APPENDIX	56
-----------------------	-----------

SECTION 1.0. DESCRIPTION AND SPECIFICATIONS

- COMPLETE SYSTEM includes single or dual input analyzer, sensor(s), and debubbler assembly
- CHOOSE U.S. EPA METHOD 180.1 or ISO METHOD 7027 compliant sensors
- RESOLUTION 0.001 NTU
- FULL FEATURED ANALYZER with fully scalable analog outputs and fully programmable alarms with interval timers
- INTUITIVE, USER-FRIENDLY MENU in seven languages makes setup and calibration easy

Clarity II is a trademark of Emerson Process Management.

1.1 FEATURES AND APPLICATIONS

The Clarity II turbidimeter is intended for the determination of turbidity in water. Low stray light, high stability, efficient bubble rejection, and a display resolution of 0.001 NTU make Clarity II ideal for monitoring the turbidity of filtered drinking water. The Clarity II turbidimeter can be used in applications other than drinking water treatment. Examples are monitoring wastewater discharges, condensate returns, and clarifiers.

Both USEPA 180.1 and ISO 7027-compliant sensors are available. USEPA 180.1 sensors use a visible light source. ISO 7027 sensors use a near infrared LED. For regulatory monitoring in the United States, USEPA 180.1 sensors must be used. Regulatory agencies in other countries may have different requirements.

The Clarity II turbidimeter consists of an analyzer, which accepts either one or two sensors, the sensors themselves, and a debubbler/measuring chamber and cable for each sensor. The cable plugs into the sensor and the analyzer, making setup fast and easy. Sensors can be located as far as 50 ft (15.2 m) away from the analyzer.

The Clarity II turbidimeter incorporates the popular and easy to use Model 1056 analyzer. Menu flows and prompts are so intuitive that a manual is practically not needed. Analog outputs are fully scalable. Alarms are fully programmable for high/low logic and dead band. To simplify programming, the analyzer automatically detects whether an EPA 180.1 or ISO 7027 sensor is being used.

Clarity II is available in an optional configuration in which the analyzer, sensor(s), and debubbling flow cell(s) are mounted on a single back plate. The sensor cables are pre-wired to the analyzer, so setup is exceptionally fast and easy. All the user does is mount the unit on a wall, bring in power and sample, and provide a drain. To order this option, consult the factory.

SPECIFICATIONS - General

Enclosure: Polycarbonate. Type 4X/CSA 4 (IP65).
Dimensions: Overall 155 x 155 x 131mm (6.10 x 6.10 x 5.15 in.). Cutout: 1/2 DIN 139mm x 139mm (5.45 x 5.45 in.)



Conduit Openings: Accepts 1/2" or PG13.5 conduit fittings

Display: Monochromatic graphic liquid crystal display. 128 x 96 pixel display resolution. Backlit. Active display area: 58 x 78mm (2.3 x 3.0 in.).

Ambient Temperature and Humidity: 0 to 55°C (32 to 131°F). Turbidity only: 0 to 50°C (32 to 122°F), RH 5 to 95% (non-condensing)

Storage Temperature Effect: -20 to 60°C (-4 to 140°F)

Hazardous Location Approvals -

Options for CSA: 02, 03, 20, 21, 22, 24, 25, 26, 27, 30, 31, 32, 34, 35, 36, 37, 38, AN, and HT.



-LR 34186
C US

Class I, Division 2, Groups A, B, C, & D
 Class II, Division 2, Groups E, F, & G
 Class III T4A Tamb= 50°C

Evaluated to the ANSI/UL Standards. The 'C' and 'US' indicators adjacent to the CSA Mark signify that the product has been evaluated to the applicable CSA and ANSI/UL Standards, for use in Canada and the U.S. respectively

POLLUTION DEGREE 2: Normally only non-conductive pollution occurs. Occasionally, however, a temporary conductivity caused by condensation must be expected.
 Altitude: for use up to 2000 meter (6562 ft.)

Power: Code -02: 20 to 30 VDC. 15 W.
 Code -03: 85 to 265 VAC, 47.5 to 65.0 Hz, switching. 15 W.
 Note: Code -02 and -03 power supplies include 4 programmable relays

Equipment protected by double insulation

RFI/EMI: EN-61326

LVD: EN-61010-1



Alarms relays*: Four alarm relays for process measurement(s) or temperature. Any relay can be configured as a fault alarm instead of a process alarm. Each relay can be configured independently and each can be programmed with interval timer settings.

Relays: Form C, SPDT, epoxy sealed



Maximum Relay Current	
	Resistive
28 VDC	5.0 A
115 VAC	5.0 A
230 VAC	5.0 A

Inductive load: 1/8 HP motor (max.), 40 VAC

⚠ CAUTION
RISK OF ELECTRICAL SHOCK

*Relays only available with -02 power supply (20 - 30 VDC) or -03 switching power supply (85 - 265 VAC)

⚠ WARNING
Exposure to some chemicals may degrade the sealing properties used in the following devices: Zettler Relays (K1-K4) PN AZ8-1CH-12DSEA

Inputs: One or two isolated sensor inputs

Outputs: Two 4-20 mA or 0-20 mA isolated current outputs. Fully scalable. Max Load: 550 Ohm. Output 1 has superimposed HART signal (configurations 1056-0X-2X-3X-HT only)

Current Output Accuracy: ±0.05 mA @ 25 °C

Terminal Connections Rating: Power connector (3-leads): 24-12 AWG wire size. Signal board terminal blocks: 26-16 AWG wire size. Current output connectors (2-leads): 24-16 AWG wire size. Alarm relay terminal blocks: 24-12 AWG wire size (-02 24 VDC power supply and -03 85-265VAC power supply)

SPECIFICATIONS — SENSOR

Method: EPA 180.1 or ISO 7027 (using 860 nm LED source). Must be specified when ordering.

Incandescent lamp life: two years

LED life: five years

Wetted materials: Delrin¹, glass, EPDM

Accuracy after calibration at 20.0 NTU:

0 - 1 NTU: $\pm 2\%$ of reading or ± 0.015 NTU, whichever is greater.

0 - 20 NTU: $\pm 2\%$ of reading

Note: Turbidity values of 2-200 NTU can be measured, but frequent cleaning may be required to maintain turbidity measurements.

Cable: 20 ft (6.1 m) or 50 ft (15.2 m). Maximum 50 ft (15.2 m). Connector is IP65.

Maximum Pressure: 30 psig (308 kPa abs)

Temperature: 40 - 95°F (5 - 35°C)

Sensor body rating: IP65 when cable is connected

SPECIFICATIONS — DEBUBBLER AND FLOW CHAMBER

Dimensions: 18.1 in. x 4.1 in. diam. (460 mm x 104 mm diam.) (approx.)

Wetted materials: ABS, EPDM, Delrin¹, polypropylene, nylon

Inlet: compression fitting accepts 1/4 in. OD tubing; fitting can be removed to provide 1/4 in. FNPT

Drain: barbed fitting accepts 3/8 in. ID tubing; fitting can be removed to provide 1/4 in. FNPT. Must drain to atmosphere.

Sample temperature: 40 - 95°F (5 - 35°C)

Minimum inlet pressure : 3.5 psig (125 kPa abs). 3.5 psig will provide about 250 mL/min sample flow.

Maximum inlet pressure: 30 psig (308 kPa abs). Do not block drain tube.

Recommended sample flow: 250 - 750 mL/min

Response Time: The table shows the time in minutes to percent of final value following a step change in turbidity.

¹Delrin is a registered trademark of DuPont Performance Elastomers.

SPECIFICATIONS — MISCELLANEOUS

Weight/shipping weight:

Sensor: 1 lb/2 lb (0.5 kg/1.0 kg)

Analyzer: 2 lb/3 lb (1.0 kg/1.5 kg)

Debubbler: 3 lb/4 lb (1.5 kg/2.0 kg)

(rounded to the nearest lb or 0.5 kg)

This page left blank intentionally.

SECTION 2.0. INSTALLATION

2.1 UNPACKING AND INSPECTION 2.2 INSTALLATION

2.1 UNPACKING AND INSPECTION

The Clarity II Turbidimeter is a complete system for the determination of turbidity in drinking water. The system consists of the analyzer, sensor(s), cable(s), and flow chamber/debubbler(s). Consult the table to verify that you have received the parts for the option you ordered.

Item	Model/part number
Single Input Turbidity Analyzer	1056-03-27-38-AN
Dual Input Turbidity Analyzer	1056-03-27-37-AN
Single Input Turbidity Analyzer with HART	1056-03-27-38-HT
Dual Input Turbidity Analyzer with HART	1056-03-27-37-HT
Sensor-EPA standard	8-0108-0002-EPA
Sensor-ISO standard	8-0108-0003-ISO
Cable-3 ft (0.9 m)	24138-00
Cable-20 ft (6.1 m)	24097-00
Cable-50 ft (15.2 m)	24098-00
Calibration cup	24101-00
Molded chamber/debubbler	24170-00

(1) The analyzer model number is printed on a label attached to the side of the instrument.

2.2 INSTALLATION

2.2.1 General Information

1. Although the analyzer is suitable for outdoor use, do not install it in direct sunlight or in areas of extreme temperatures.
2. Install the analyzer in an area where vibration and electromagnetic and radio frequency interference are minimized or absent.
3. Keep the analyzer and sensor wiring at least one foot from high voltage conductors. Be sure there is easy access to the analyzer.
4. The analyzer is suitable for panel, pipe, or surface mounting. Refer to the table below.

Type of Mounting	Figure
Panel	2-1
Wall and Pipe	2-2

	<p>WARNING RISK OF ELECTRICAL SHOCK</p>
<p>Electrical installation must be in accordance with the National Electrical Code (ANSI/NFPA-70) and/or any other applicable national or local codes.</p>	

FIGURE 2-1 PANEL MOUNTING DIMENSIONS



Note: Panel mounting seal integrity (4/4X) for outdoor applications is the responsibility of the end user.

FIGURE 2-2 PIPE AND WALL MOUNTING DIMENSIONS

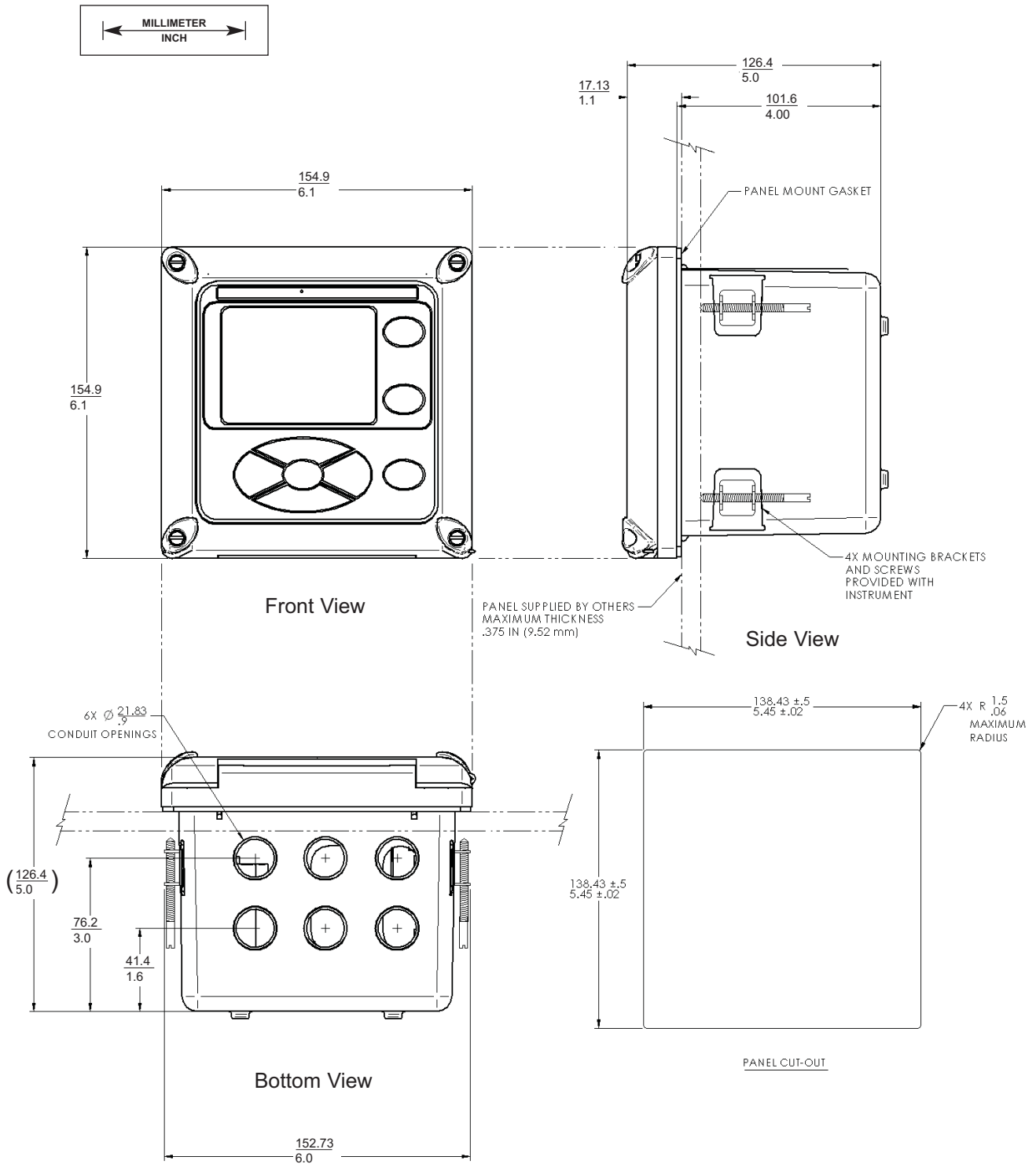
(Mounting bracket PN:23820-00)

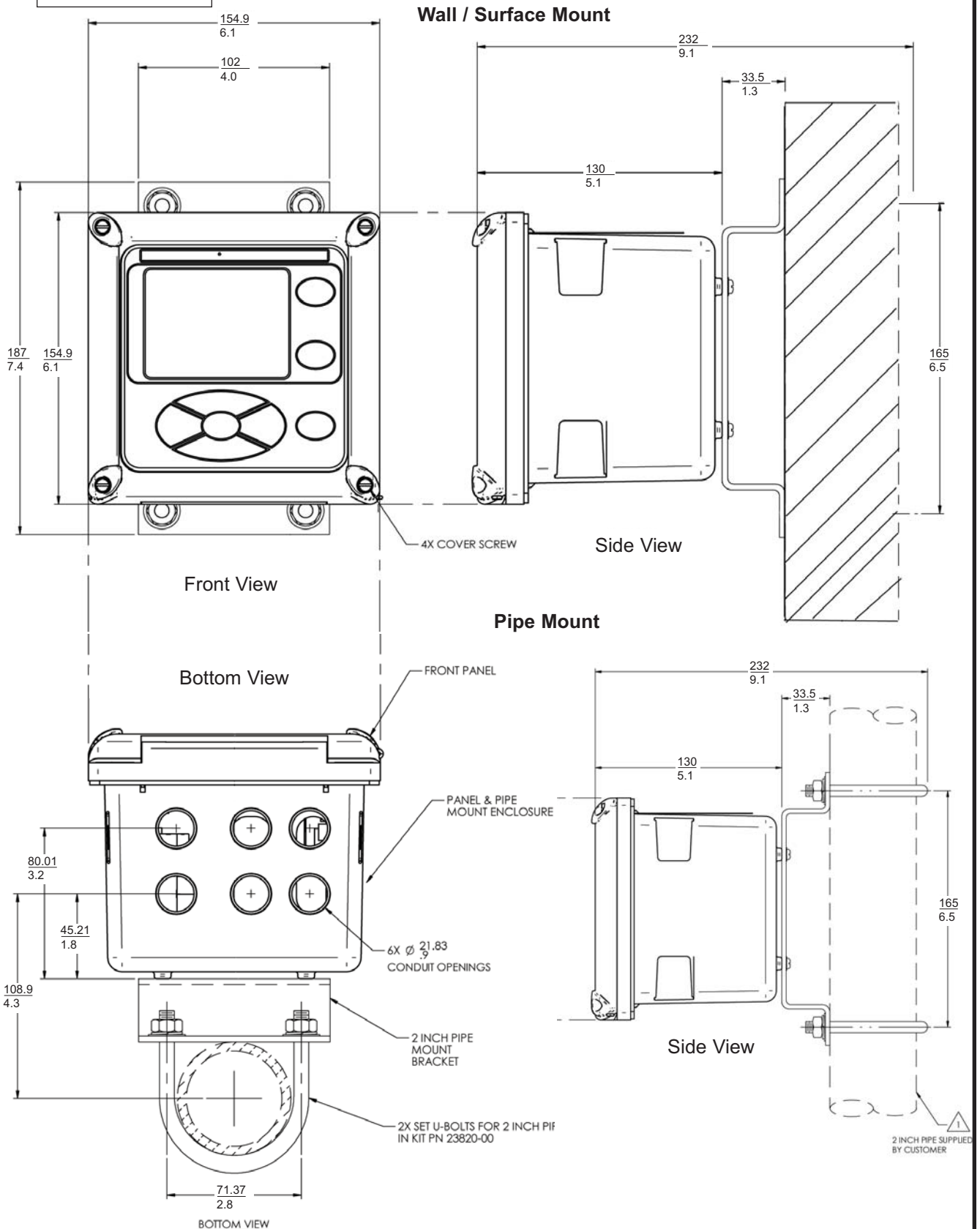

The front panel is hinged at the bottom. The panel swings down for easy access to the wiring locations.

2.3 INSTALLATION — DEBUBBLER ASSEMBLY



See Figure 2-3 for installation.

Connect the sample line to the inlet fitting. The fitting accepts 1/4-inch OD tubing. See Section 2.6 for recommended installation of the sample port.

Attach a piece of 3/8 inch ID soft tubing to the drain fitting. The debubbler **must** drain to atmosphere.

NOTE

During operation, the debubbler is under pressure. A 0.040 inch (1 mm) orifice in the outlet provides the pressure. Back pressure helps prevent outgassing, which can lead to bubbles accumulating on the sensor face resulting in erroneous readings. **DO NOT EXCEED 30 psig (308 kPa abs) inlet pressure.**

 <b style="font-size: 1.2em;">WARNING 
<p>Before removing the sensor, be absolutely certain that the process pressure is reduced to 0 psig and the process temperature is lowered to a safe level!</p>

The amount of pressure in the debubbler can be estimated from the flow rate. See Table 2-1.

To control and monitor sample flow, a valved rotameter with fittings is available (PN 24103-00). Attach the rotameter to the debubbler outlet. The rotameter can also be used to increase back pressure on the debubbler if additional pressure is needed to prevent outgassing.

gph	psig	mL/min	kPa abs
2	1	100	110
4	3	200	120
6	8	300	140
8	14	400	160
10	21	500	190
11	26	600	240
12	31	700	280
—	—	800	340

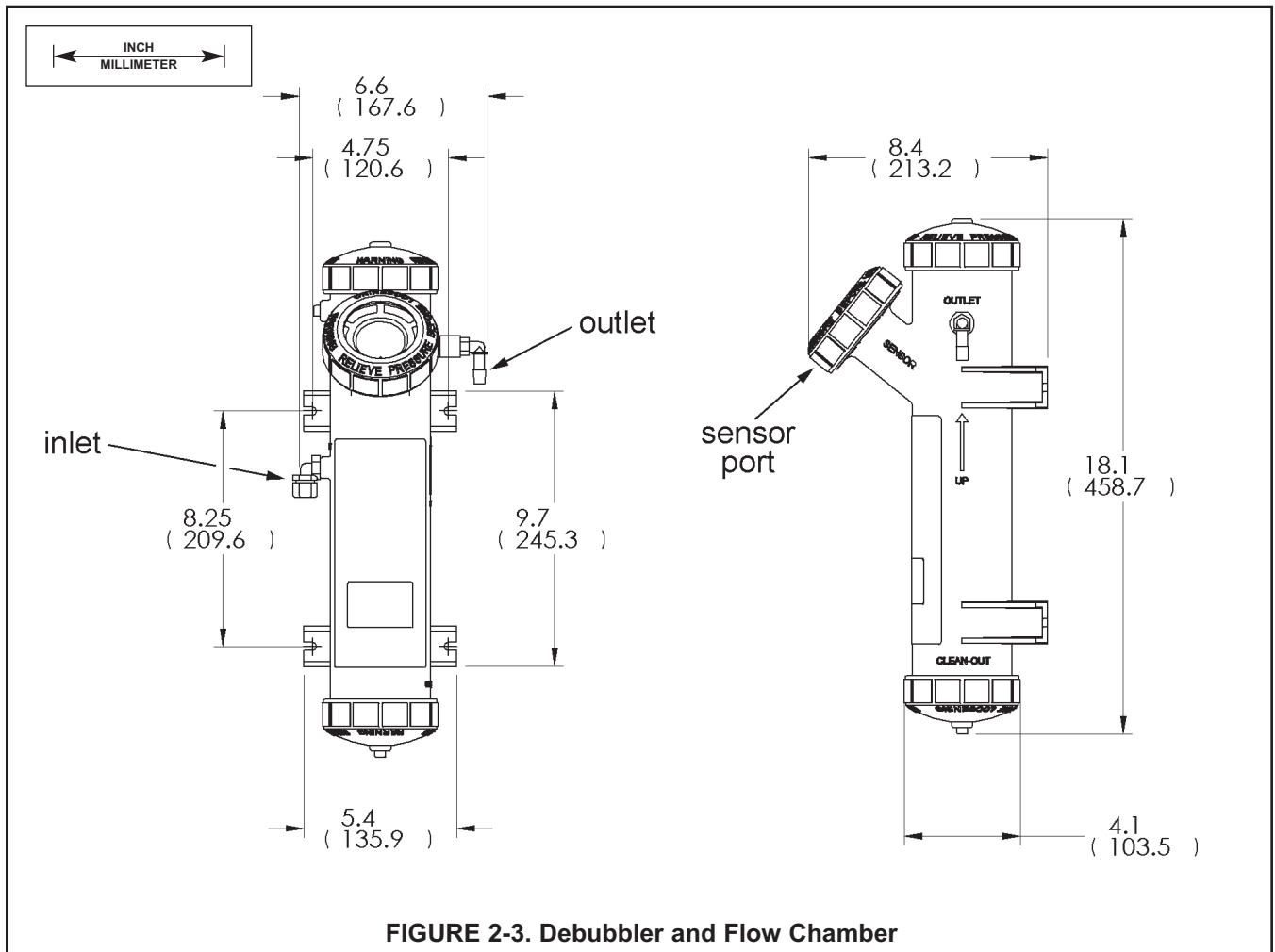

2.4 INSTALLATION — SENSOR

Unscrew the nut on the side of the debubbler. Insert the sensor in the mouth of the measuring chamber. Be sure the pin on the debubbler lines up with the hole in the sensor. Replace the nut. Remove the protective cap from the sensor and screw the cable onto the receptacle. The plug and receptacle are keyed for proper alignment.

The sensor is rated to IP65 when properly connected to the cable. To prevent possible water damage to the connector contacts, be sure the cable receptacle and the connector on the back of the sensor are dry when connecting or disconnecting the cable.

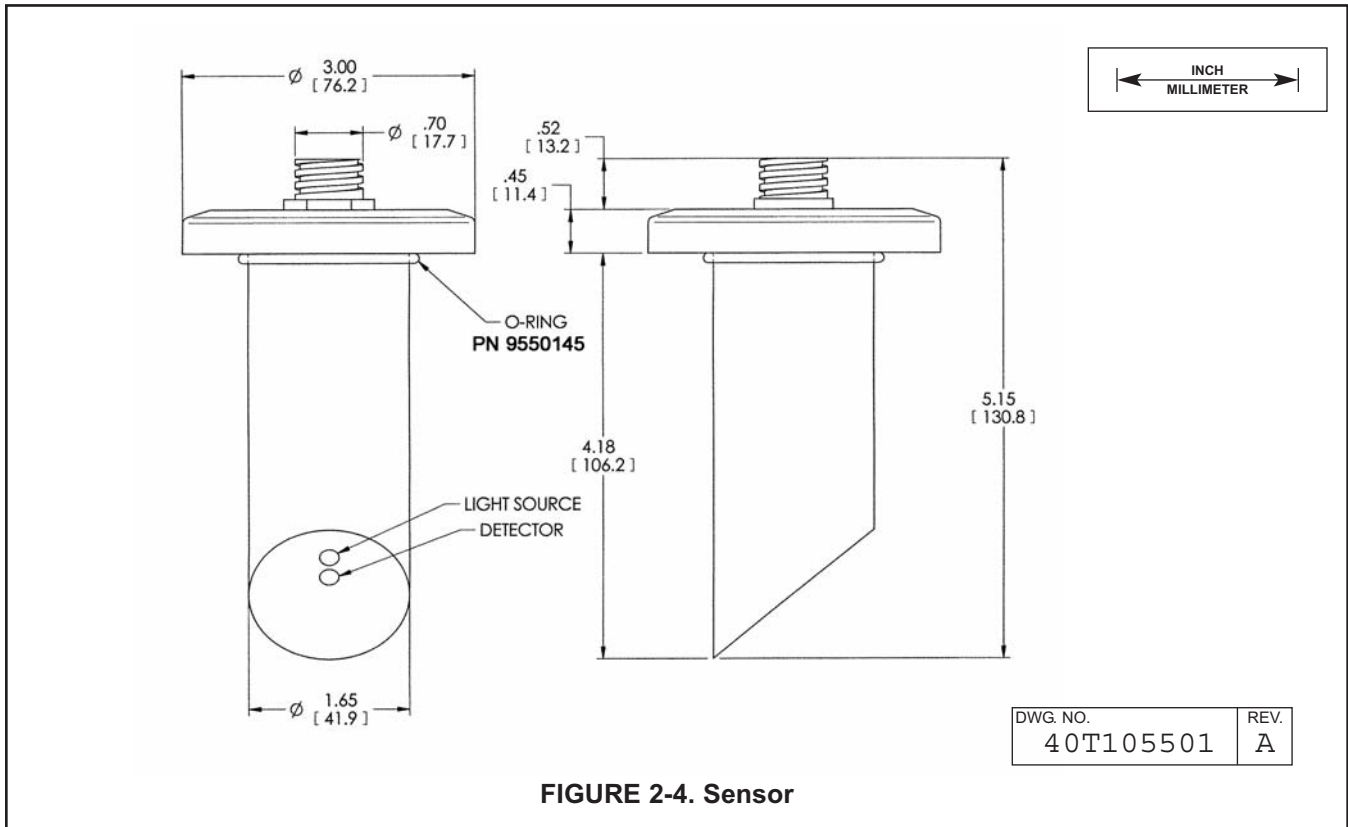

FIGURE 2-4. Sensor

2.5 SAMPLE POINT

Locate the sample tap to minimize pickup of sediment or air. See Figure 2-5. If possible, install a sampling port that extends one or two inches (25 - 50 mm) into the pipe. Use 1/4 inch OD rigid plastic tubing. Avoid soft plastic tubing if possible. To reduce sample lag time, install the debubbler and flow chamber as close to the sample tap as possible.

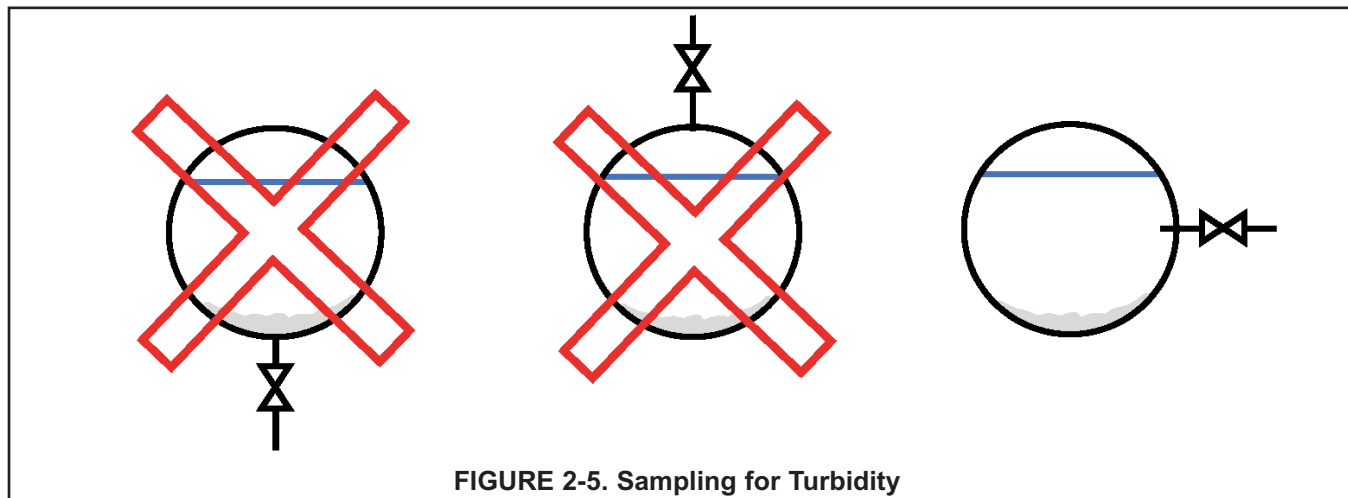
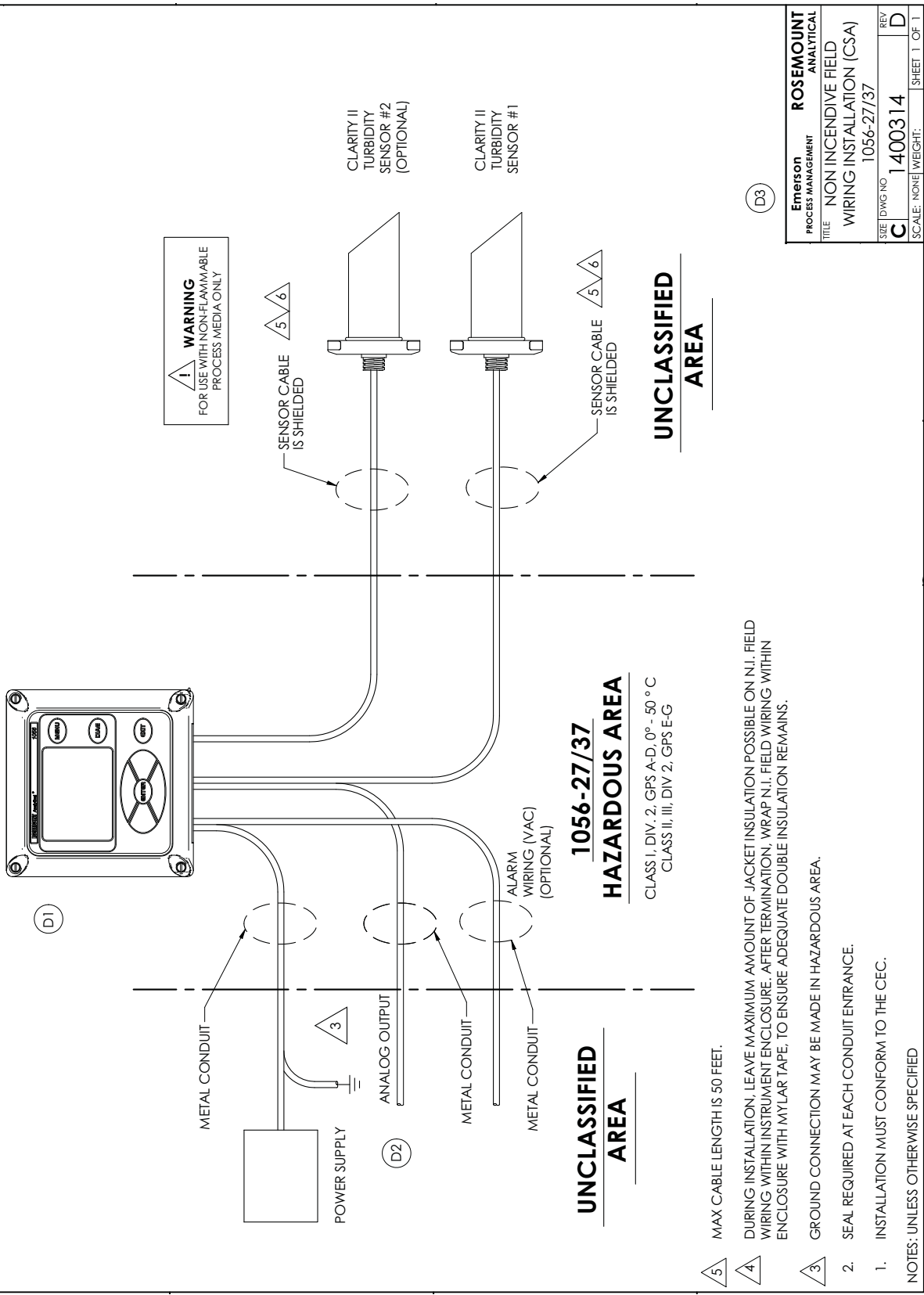

FIGURE 2-5. Sampling for Turbidity



Emerson PROCESS MANAGEMENT		ROSEMOUNT ANALYTICAL	
TITLE		NON INCENDIVE FIELD	
TITLE		WIRING INSTALLATION (CSA)	
SIZE	DWG NO.	REV	D
C	1400314		
SCALE: NONE/WEIGHT:			SHEET 1 OF 1

Figure 2-6

AMPEROMETRIC SENSOR BOARD
 OPTION -24/-34: CHLORINE
 OPTION -25/-33: DISSOLVED OXYGEN
 OPTION -26/-36: OZONE

OUTPUT PARAMETERS	AMPEROMETRIC CONNECTORS TB1, TB2, TB3
Voc, Vo	9.624 V
Isc, Io	104.07 mA
Pmax, Po	250.4 mW
Ca	26 µF
La	7.3 mH

TABLE 1A
 AMPEROMETRIC ENTITY PARAMETERS

pH SENSOR BOARD
 OPTION -22/-32: pH/ORP/ISE

OUTPUT PARAMETERS	pH TB1 CONNECTOR
Voc, Vo	9.624 V
Isc, Io	115 mA
Pmax, Po	276.8 mW
Ca	26 µF
La	6 mH

TABLE 1B
 pH/ORP/ISE ENTITY PARAMETERS

CONTACTING CONDUCTIVITY BOARD
 OPTION -20/-30: CONTACTING CONDUCTIVITY

OUTPUT PARAMETERS	CONDUCTIVITY CONNECTORS TB1, TB2
Voc, Vo	6.633 V
Isc, Io	30.45 mA
Pmax, Po	50.5 mW
Ca	250 µF
La	85 mH

TABLE 1C
 CONTACTING CONDUCTIVITY ENTITY PARAMETERS

TURBIDITY SENSOR BOARD
 OPTION -27/-37: TURBIDITY

MAY ONLY BE USED WITH A CLARITY II TURBIDITY SENSOR.

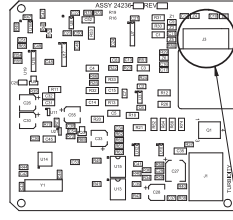
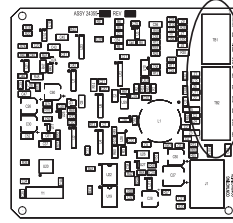
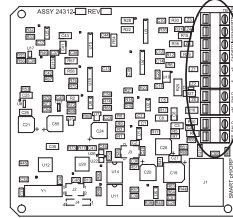
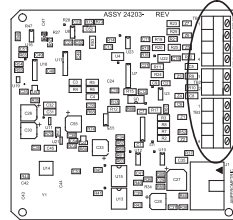

NON-INCANDIVE FIELD WIRING CONNECTIONS FOR CLASS 1, DIVISION 2, GROUPS ABCD

NON INCANDIVE FIELD WIRING INSTALLATION (CSA),
 56
 DWG NO 1400668 REV B

SHEET 2 OF 2

Figure 2-7

SECTION 3.0.

WIRING

3.1 GENERAL

3.2 PREPARING CONDUIT OPENINGS

3.3 PREPARING SENSOR CABLE

3.4 POWER, OUTPUT, AND SENSOR CONNECTIONS

3.1 GENERAL

The 1056 is easy to wire. It includes removable connectors and slide-out signal input boards.

3.1.1. Removable connectors and signal input boards

Model 1056 uses removable signal input boards and communication boards for ease of wiring and installation. Each of the signal input boards can be partially or completely removed from the enclosure for wiring. The Model 1056 has three slots for placement of up to two signal input boards and one communication board.

Slot 1-Left	Slot 2 – Center	Slot 3 – Right
Comm. board	Input Board 1	Input Board 2

3.1.2. Signal Input boards

Slots 2 and 3 are for signal input measurement boards. Wire the sensor leads to the measurement board following the lead locations marked on the board. After wiring the sensor leads to the signal board, carefully slide the wired board fully into the enclosure slot and take up the excess sensor cable through the cable gland. Tighten the cable gland nut to secure the cable and ensure a sealed enclosure.

3.1.3. Digital Communication boards

HART and Profibus DP communication boards will be available in the future as options for Model 1056 digital communication with a host. The HART board supports Bell 202 digital communications over an analog 4-20mA current output. Profibus DP is an open communications protocol which operates over a dedicated digital line to the host.

3.1.4 Alarm relays

Four alarm relays are supplied with the switching power supply (85 to 265VAC, -03 order code) and the 24VDC power supply (20-30VDC, -02 order code). All relays can be used for process measurement(s) or temperature. Any relay can be configured as a fault alarm instead of a process alarm. Each relay can be configured independently and each can be programmed as an interval timer, typically used to activate pumps or control valves. As process alarms, alarm logic (high or low activation or USP*) and deadband are user-programmable. Customer-defined failsafe operation is supported as a programmable menu function to allow all relays to be energized or not-energized as a default condition upon powering the analyzer.

The USP* alarm can be programmed to activate when the conductivity is within a user-selectable percentage of the limit. USP alarming is available only when a contacting conductivity measurement board is installed.

3.2 PREPARING CONDUIT OPENINGS

There are six conduit openings in all configurations of Model 1056. (Note that four of the openings will be fitted with plugs upon shipment.)

Conduit openings accept 1/2-inch conduit fittings or PG13.5 cable glands. To keep the case watertight, block unused openings with Type 4X or IP65 conduit plugs.

NOTE: Use watertight fittings and hubs that comply with your requirements. Connect the conduit hub to the conduit before attaching the fitting to the analyzer.

3.3 PREPARING SENSOR CABLE

The Model 1056 is intended for use with all Rosemount Analytical sensors. Refer to the sensor installation instructions for details on preparing sensor cables.

3.4 POWER, OUTPUT, AND SENSOR CONNECTIONS

3.4.1 Power wiring

Two Power Supplies are offered for Model T1056:

- a. 24VDC (20 – 30V) Power Supply (-02 ordering code)
- b. 85 – 265 VAC Switching Power Supply (-03 ordering code)

AC mains (115 or 230V) leads and 24VDC leads are wired to the Power Supply board which is mounted vertically on the left side of the main enclosure cavity. Each lead location is clearly marked on the Power Supply board. Wire the power leads to the Power Supply board using the lead markings on the board.

24VDC Power Supply (-02 ordering code) is shown below:



This power supply automatically detects DC power and accepts 20VDC to 30VDC inputs. Four programmable alarm relays are included.

Figure 3-1

Switching AC Power Supply (-03 ordering code) is shown below:

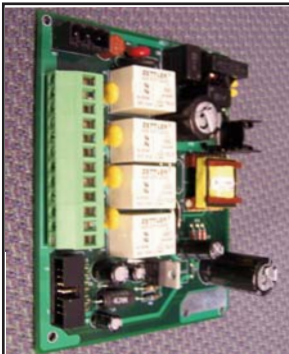

This power supply automatically detects AC line conditions and switches to the proper line voltage and line frequency. Four programmable alarm relays are included.

Figure 3-2

3.4.2 Current Output wiring

All instruments are shipped with two 4-20mA current outputs. Wiring locations for the outputs are on the Main board which is mounted on the hinged door of the instrument. Wire the output leads to the correct position on the Main board using the lead markings (+/positive, -/negative) on the board. Male mating connectors are provided with each unit.

For best EMI/RFI protection use shielded output signal cable enclosed in an earth-grounded metal conduit. Connect the shield to earth ground. AC wiring should be 14 gauge or greater. Provide a switch or breaker to disconnect the analyzer from the main power supply. Install the switch or breaker near the analyzer and label it as the disconnecting device for the analyzer.

Keep sensor and output signal wiring separate from power wiring. Do not run sensor and power wiring in the same conduit or close together in a cable tray.

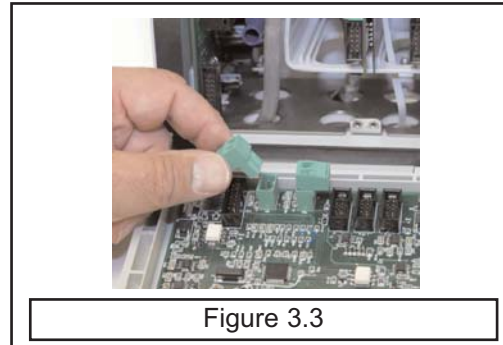



Figure 3.3

3.4.3 Alarm relay wiring

Four alarm relays are supplied with the switching power supply (85 to 265VAC, -03 order code) and the 24VDC power supply (20-30VDC, -02 order code). Wire the relay leads on each of the independent relays to the correct position on the power supply board using the printed lead markings (NO/Normally Open, NC/Normally Closed, or Com/Common) on the board. See Fig 3-3.

NO1	RELAY 1	
COM1		
NC1		
NO2	RELAY 2	
COM2		
NC2		
NO3	RELAY 3	
COM3		
NC3		
NO4	RELAY 4	
COM4		
NC4		
Figure 3-4 Alarm Relay Wiring for Model 1056 Switching Power Supply (-03 Order Code)		

3.4.4 Sensor wiring to signal boards

Plug the pre-terminated sensor cable connector directly into the turbidity signal board mating connector.

	<p>WARNING RISK OF ELECTRICAL SHOCK</p>
<p>Electrical installation must be in accordance with the National Electrical Code (ANSI/NFPA-70) and/or any other applicable national or local codes.</p>	

3.2.2 Sensor

The sensor cable is pre-wired to a plug that inserts into a receiving socket on the signal board. See Figures 3-1. The cable also passes through a strain relief fitting. To install the cable...

1. Remove the wrenching nut from the strain relief fitting.
2. Insert the plug through the hole in the bottom of the enclosure nearest the sensor socket. Seat the fitting in the hole.
3. Slide the wrenching nut over the cable plug and screw it onto the fitting.
4. Loosen the cable nut so the cable slides easily.
5. Insert the plug into the appropriate receptacle. To remove the plug, squeeze the release clip and pull straight out.
6. Adjust the cable slack in the enclosure and tighten the cable nut. Be sure to allow sufficient slack to avoid placing stress on the cable and connections.
7. Plug the cable into the back of the sensor. The sensor is rated to IP65 when properly connected to the cable. To prevent possible water damage to the connector contacts, be sure the cable receptacle and the connector on the back of the sensor are dry when connecting or disconnecting the cable.
8. Place the sensor in either the measuring chamber or the calibration cup. **The sensor must be in a dark place when power is first applied to the analyzer.**

Note: If "S1 Warning" appears, check sensor cable connection and confirm sample water flow at debubbler drain outlet.

Figure 3-5 Turbidity signal board with plug-in Sensor connection

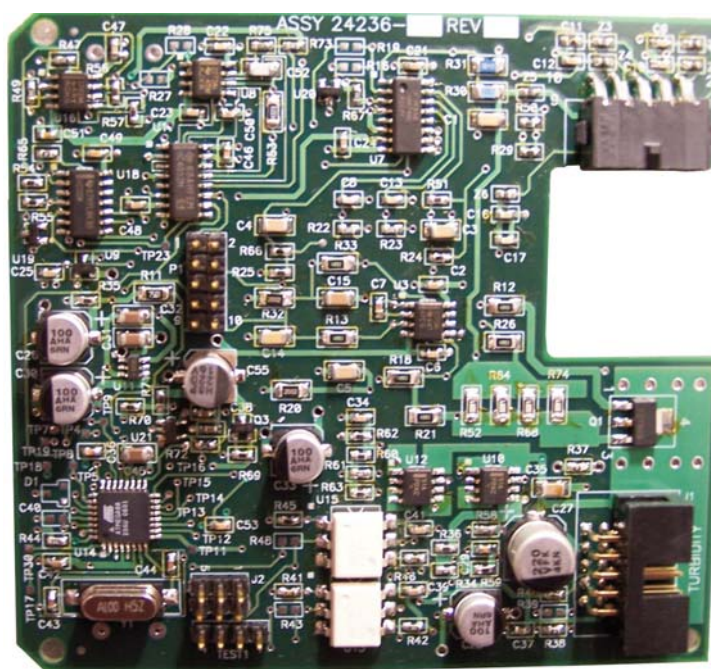

IMPORTANT NOTE:

When using EPA/incandescent sensors (PN 8-0108-0002-EPA):

- n DO NOT power up the instrument without the sensor connected
- n DO NOT disconnect and reconnect a sensor while an analyzer is powered

If this is inconvenient or cannot be avoided:

3. Cycle power to the instrument after connecting the sensor or...
4. Perform a Slope Calibration or Standard Calibration routine after connecting the sensor.

Following these guidelines will extend the life of the incandescent lamp and avoid premature warnings and faults due to reduced lamp life.

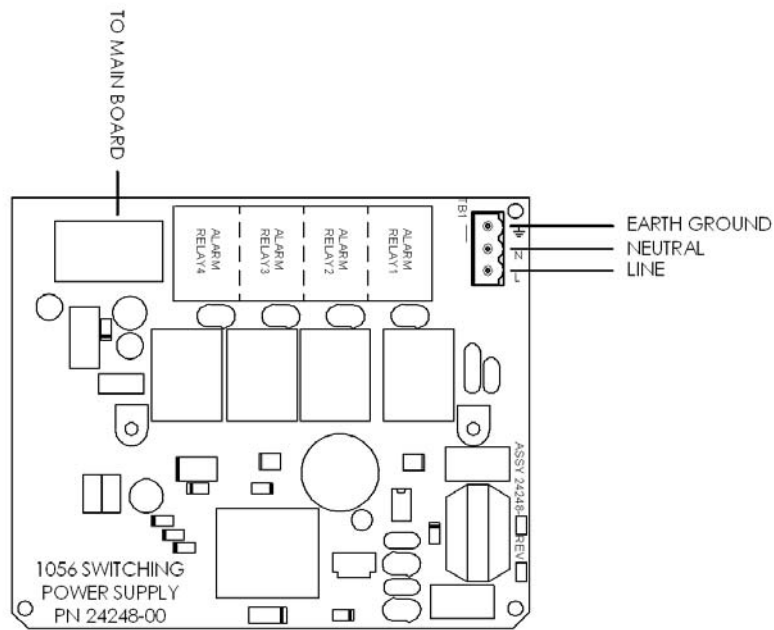

FIGURE 3-6 Power Wiring for Model 1056 85-265 VAC Power Supply (-03 ordering code)

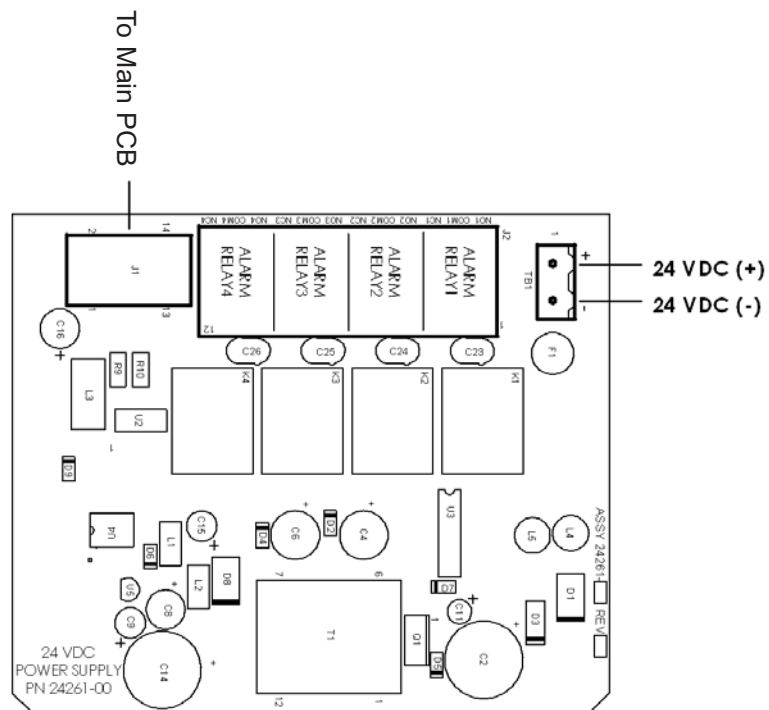

FIGURE 3-7 Power Wiring for Model 1056 24VDC Power Supply (-02 ordering code)

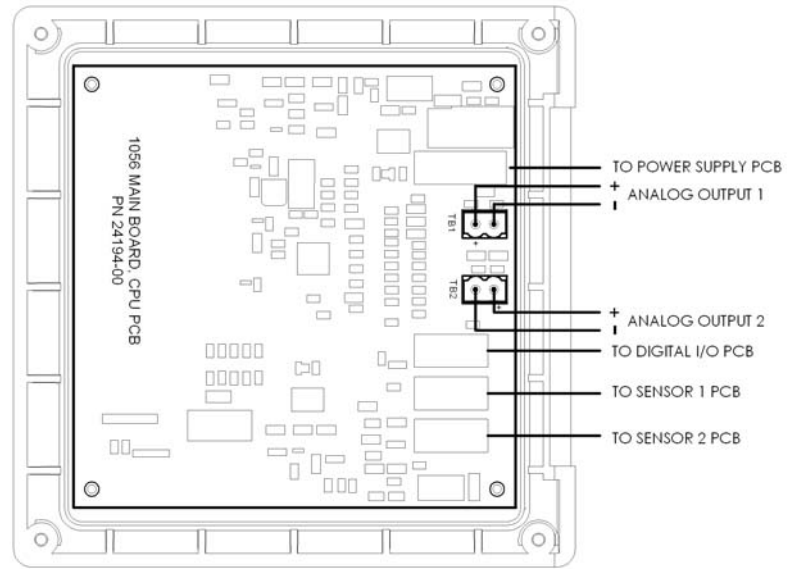

FIGURE 3-8 Output Wiring for Model 1056 Main PCB

SECTION 4.0 DISPLAY AND OPERATION

4.1 USER INTERFACE

4.2 KEYPAD

4.3 MAIN DISPLAY

4.4 MENU SYSTEM

4.1 USER INTERFACE

The Model 1056 has a large display which shows two live measurement readouts in large digits and up to four additional process variables or diagnostic parameters concurrently. The display is back-lit and the format can be customized to meet user requirements. The intuitive menu system allows access to Calibration, Hold (of current outputs), Programming, and Display functions by pressing the MENU button. In addition, a dedicated DIAGNOSTIC button is available to provide access to useful operational information on installed sensor(s) and any problematic conditions that might occur. The display flashes Fault and/or Warning when these conditions occur. Help screens are displayed for most fault and warning conditions to guide the user in troubleshooting.

During calibration and programming, key presses cause different displays to appear. The displays are self-explanatory and guide the user step-by-step through the procedure.



4.2 INSTRUMENT KEYPAD

There are 4 Function keys and 4 Selection keys on the instrument keypad.

Function keys:

The **MENU key** is used to access menus for programming and calibrating the instrument. Four top-level menu items appear when pressing the MENU key:

- **Calibrate:** calibrate attached sensors and analog outputs.
- **Hold:** Suspend current outputs.
- **Program:** Program outputs, measurement, temperature, security and reset.
- **Display:** Program display format, language, warnings, and contrast

Pressing MENU always causes the main menu screen to appear. Pressing MENU followed by EXIT causes the main display to appear.

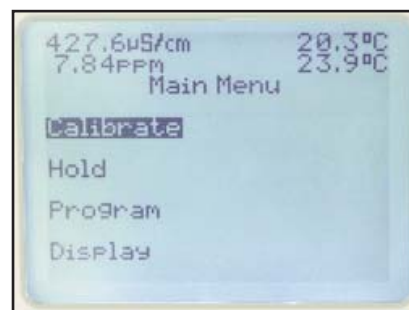

Pressing the **DIAG** key displays active Faults and Warnings, and provides detailed instrument information and sensor diagnostics including: Faults, Warnings, Sensor 1 and 2 information, Out 1 and Out 2 live current values, model configuration string e.g. 1056-01-20-31-AN, Instrument Software version, and AC frequency used. Pressing ENTER on Sensor 1 or Sensor 2 provides useful diagnostics and information (as applicable): Measurement, Sensor Type, Raw signal value, Cell constant, Zero Offset, Temperature, Temperature

Offset, selected measurement range, Cable Resistance, Temperature Sensor Resistance, Signal Board software version.

The ENTER key. Pressing ENTER stores numbers and settings and moves the display to the next screen.

The EXIT key. Pressing EXIT returns to the previous screen without storing changes.

Selection keys:

Surrounding the ENTER key, four Selection keys – up, down, right and left, move the cursor to all areas of the screen while using the menus.

Selection keys are used to:

1. select items on the menu screens
2. scroll up and down the menu lists.
3. enter or edit numeric values.
4. move the cursor to the right or left
5. select measurement units during operations

4.3 MAIN DISPLAY

The Model 1056 displays one or two primary measurement values, up to four secondary measurement values, a fault and warning banner, alarm relay flags, and a digital communications icon.



Process measurements:

Two process variables are displayed if two signal boards are installed. One process variable and process temperature is displayed if one signal board is installed with one sensor. The Upper display area shows the Sensor 1 process reading. The Center display area shows the Sensor 2 process reading.

For single input configurations, the Upper display area shows the live process variable.

Secondary values:

Up to four secondary values are shown in four display quadrants at the bottom half of the screen. All four secondary value positions can be programmed by the user to any display parameter available. Possible secondary values include:

Displayable Secondary Values	
Slope 1	Man Temp 2
Ref Off 1	Output 1 mA
GI Imp 1	Output 2 mA
Ref Imp 1	Output 1 %
Raw	Output 2 %
mV Input	Measure 1
Temp 1	Blank
Man Temp 1	

Fault and Warning banner:

If the analyzer detects a problem with itself or the sensor the word Fault or Warning will appear at the bottom of the display. A fault requires immediate attention. A warning indicates a problematic condition or an impending failure. For troubleshooting assistance, press Diag.

Formatting the Main Display

The main display screen can be programmed to show primary process variables, secondary process variables and diagnostics.

1. Press MENU
2. Scroll down to **Display**. Press ENTER.
3. **Main Format** will be highlighted. Press ENTER.
4. The sensor 1 process value will be highlighted in reverse video. Press the selection keys to navigate down to the screen sections that you wish to program. Press **ENTER**.
5. Choose the desired display parameter or diagnostic for each of the four display sections in the lower screen.
6. Continue to navigate and program all desired screen sections. Press **MENU** and **EXIT**. The screen will return to the main display.

For single sensor configurations, the default display shows the live process measurement in the upper display area and temperature in the center display area. The user can elect to disable the display of temperature in the center display area using the Main Format function. See Fig. 4-1 to guide you through programming the main display to select process parameters and diagnostics of your choice.

For dual sensor configurations, the default display shows Sensor 1 live process measurement in the upper display area and Sensor 2 live process measurement temperature in the center display area. See Fig. 4-1 to guide you through programming the main display to select process parameters and diagnostics of your choice.

4.4 MENU SYSTEM

Model 1056 uses a scroll and select menu system. Pressing the MENU key at any time opens the top-level menu including Calibrate, Hold, Program and Display functions.

To find a menu item, scroll with the up and down keys until the item is highlighted. Continue to scroll and select menu items until the desired function is chosen. To select the item, press ENTER. To return to a previous menu level or to enable the main live display, press the EXIT key repeatedly. To return immediately to the main display from any menu level, simply press MENU then EXIT.

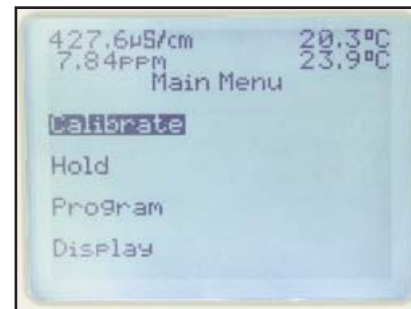

The selection keys have the following functions:

- The Up key (above ENTER) increments numerical values, moves the decimal place one place to the right, or selects units of measurement.
- The Down key (below ENTER) decrements numerical values, moves the decimal place one place to the left, or selects units of measurement
- The Left key (left of ENTER) moves the cursor to the left.
- The Right key (right of ENTER) moves the cursor to the right.

To access desired menu functions, use the "Quick Reference" Figure B. During all menu displays (except main display format and Quick Start), the live process measurements and secondary measurement values are displayed in the top two lines of the Upper display area. This conveniently allows display of the live values during important calibration and programming operations.

Menu screens will time out after two minutes and return to the main live display.

FIGURE 4-1 Formatting the Main Display

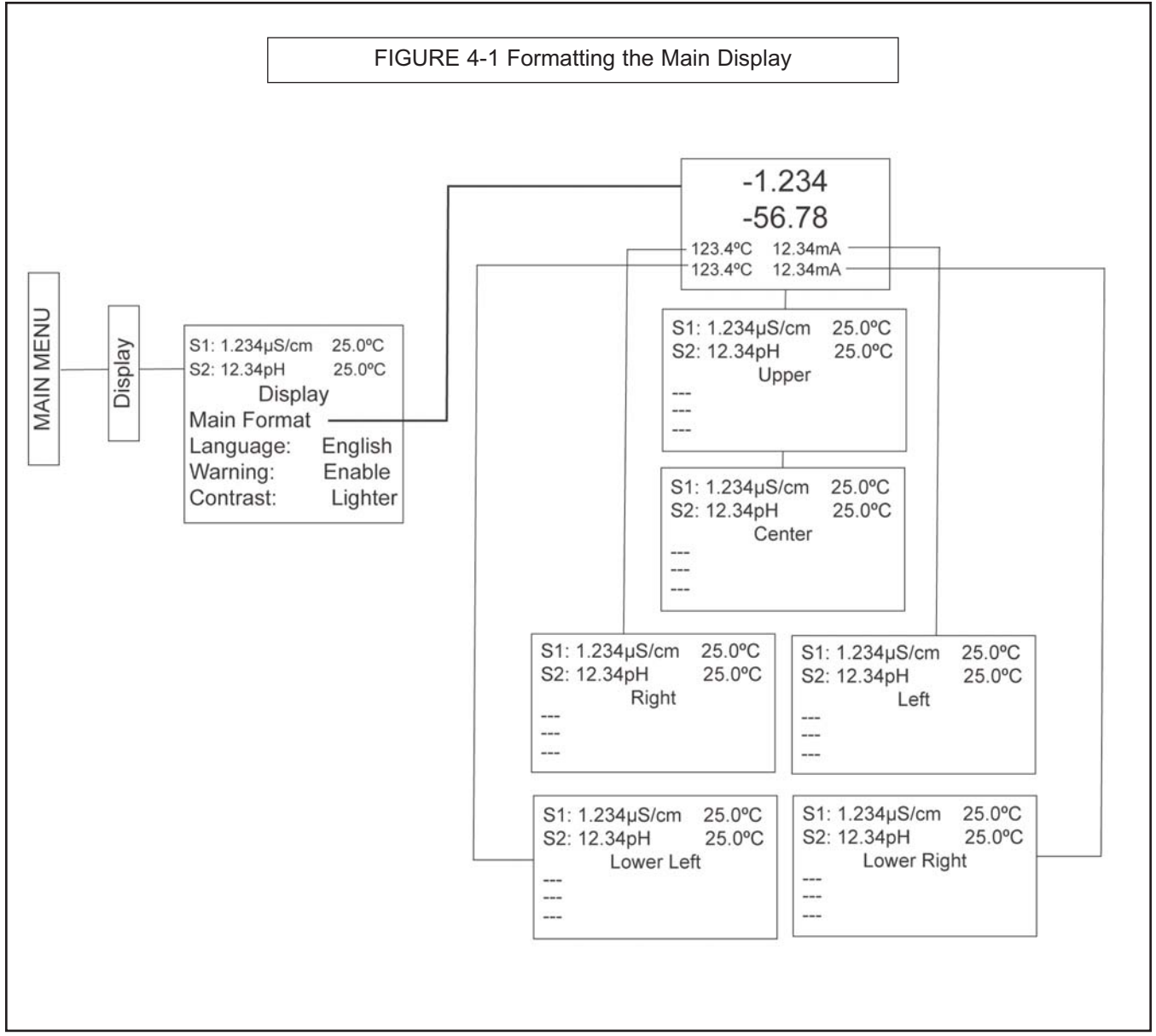

SECTION 5.0.

PROGRAMMING THE ANALYZER - BASICS

5.1 GENERAL

5.2 CHANGING START-UP SETTINGS

5.3 CONFIGURING AND RANGING 4-20MA OUTPUTS

5.4 SETTING SECURITY CODES

5.5 SECURITY ACCESS

5.6 USING HOLD

5.7 RESETTING FACTORY DEFAULTS – RESET ANALYZER

5.8 PROGRAMMING ALARM RELAYS

5.1 GENERAL

Section 5.0 describes the following programming functions:

- Changing the measurement type, measurement units and temperature units.
- Configure and assign values to the current outputs
- Set a security code for two levels of security access
- Accessing menu functions using a security code
- Enabling and disabling Hold mode for current outputs
- Resetting all factory defaults, calibration data only, or current output settings only

5.2 CHANGING STARTUP SETTINGS

5.2.1 Purpose

To change the measurement type, measurement units, or temperature units that were initially entered in Quick Start, choose the Reset analyzer function (Sec. 5.7) or access the Program menus for sensor 1 or sensor 2 (Sec. 6.0). The following choices for specific measurement type, measurement units are available for each sensor measurement board.

5.2.2 Procedure.

Follow the Reset Analyzer procedure (Sec 5.7) to reconfigure the analyzer to display new measurements or measurement units. To change the specific measurement or measurement units for each signal board type, refer to the Program menu for the appropriate measurement (Sec. 6.0).

5.3 CONFIGURING AND RANGING THE CURRENT OUTPUTS

5.3.1 Purpose

The Model 1056 accepts inputs from two sensors and has two analog current outputs. Ranging the outputs means assigning values to the low (0 or 4 mA) and high (20 mA) outputs. This section provides a guide for configuring and ranging the outputs. ALWAYS CONFIGURE THE OUTPUTS FIRST.

5.3.2 Definitions

1. CURRENT OUTPUTS. The analyzer provides a continuous output current (4-20 mA or 0-20 mA) directly proportional to the process variable or temperature.

The low and high current outputs can be set to any value.

2. ASSIGNING OUTPUTS. Assign a measurement to Output 1 or Output 2.

3. DAMPEN. Output dampening smooths out noisy readings. It also increases the response time of the output. Output dampening does not affect the response time of the display.

4. MODE. The current output can be made directly proportional to the displayed value (linear mode) or directly proportional to the common logarithm of the displayed value (log mode).

5.3.3. Procedure: Configure Outputs.

Under the Program/Outputs menu, the adjacent screen will appear to allow configuration of the outputs. Follow the menu screens in Fig. 5-2 to configure the outputs.

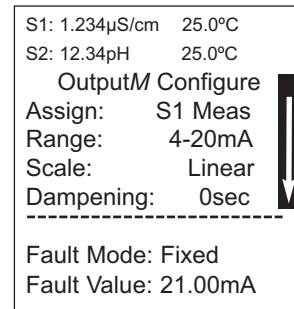

5.3.4. Procedure: Assigning Measurements the Low and High Current Outputs

The adjacent screen will appear when entering the Assign function under Program/Output/Configure. These screens allow you to assign a measurement, process value, or temperature input to each output. Follow the menu screens in Fig. 5-2 to assign measurements to the outputs.

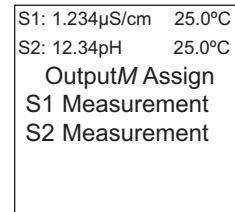

5.3.5. Procedure: Ranging the Current Outputs

The adjacent screen will appear under Program/Output/Range. Enter a value for 4mA and 20mA (or 0mA and 20mA) for each output. Follow the menu screens in Fig. 5-2 to assign values to the outputs.

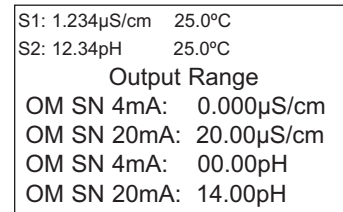
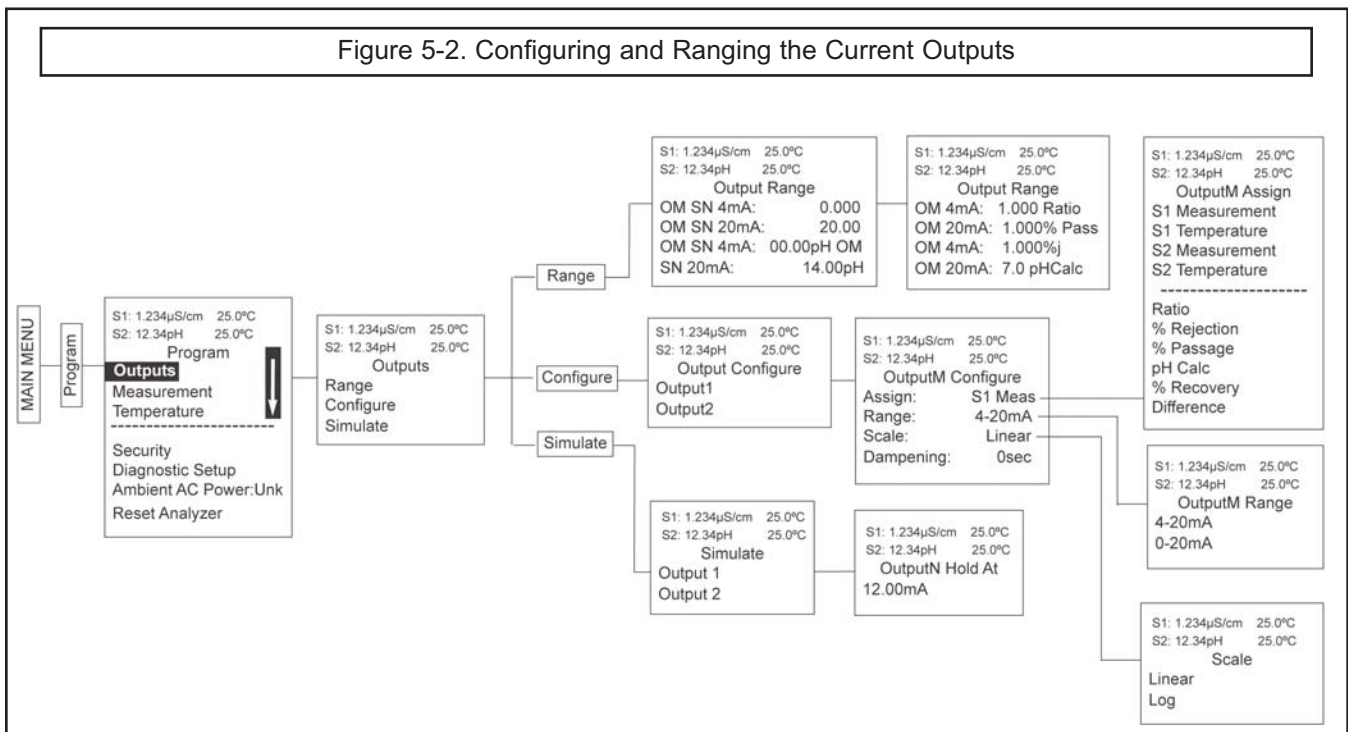

Figure 5-2. Configuring and Ranging the Current Outputs



5.4 SETTING A SECURITY CODE

5.4.1 Purpose.

The security codes prevent accidental or unwanted changes to program settings, displays, and calibration. Model 1056 has two levels of security code to control access and use of the instrument to different types of users. The two levels of security are:

- **All:** This is the Supervisory security level. It allows access to all menu functions, including Programming, Calibration, Hold and Display.
- **Calibration/Hold:** This is the operator or technician level menu. It allows access to only calibration and Hold of the current outputs.

5.4.2 Procedure.

1. Press MENU. The main menu screen appears. Choose **Program**.

2. Scroll down to Security. Select **Security**.
3. The security entry screen appears. Enter a three digit security code for each of the desired security levels. The security code takes effect two minutes after the last key stroke. Record the security code(s) for future access and communication to operators or technicians as needed.
4. The display returns to the security menu screen. Press EXIT to return to the previous screen. To return to the main display, press MENU followed by EXIT.

Fig. 5-3 displays the security code screens.

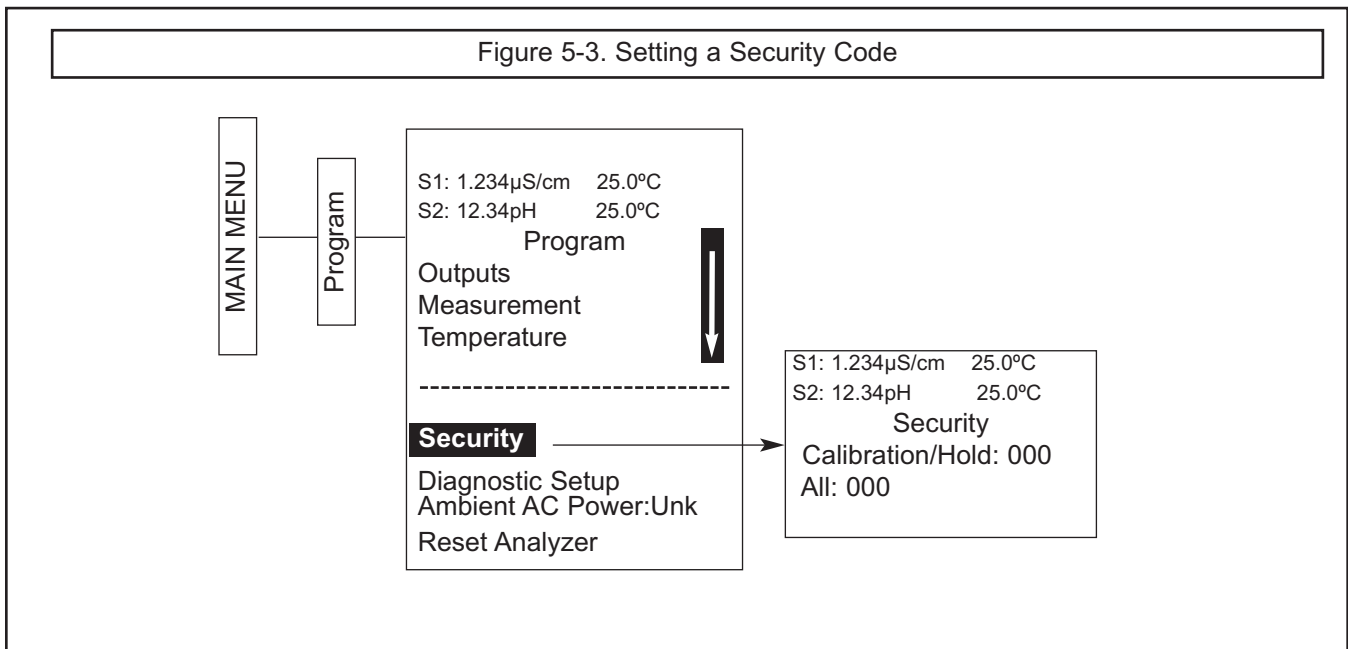

5.5 SECURITY ACCESS

5.5.1 How the Security Code Works

When entering the correct access code for the **Calibration/Hold** security level, the Calibration and Hold menus are accessible. This allows operators or technicians to perform routine maintenance. This security level does not allow access to the Program or Display menus.

When entering the correct access code for **All** security level, the user has access to all menu functions, including Programming, Calibration, Hold and Display.

5.5.2 Procedure.

1. If a security code has been programmed, selecting the Calibrate, Hold, Program or Display top menu items causes the security access screen to appear
2. Enter the three-digit security code for the appropriate security level.

S1: 1.234μS/cm	25.0°C
S2: 12.34pH	25.0°C
Security Code	
000	

3. If the entry is correct, the appropriate menu screen appears. If the entry is incorrect, the **Invalid Code** screen appears. The **Enter Security Code** screen reappears after 2 seconds.

5.6 USING HOLD

5.6.1 Purpose

The analyzer output is always proportional to measured value. To prevent improper operation of systems or pumps that are controlled directly by the current output, place the analyzer in hold before removing the sensor for calibration and maintenance. Be sure to remove the analyzer from hold once calibration is complete. During hold, both outputs remain at the last value. **Once in hold, all current outputs remain on Hold indefinitely.**

5.6.2 Using the Hold Function

To hold the outputs,

1. Press MENU. The main menu screen appears. Choose **Hold**.
2. The **Hold Outputs and Alarms?** screen appears. Choose **Yes** to place the analyzer in hold. Choose **No** to take the analyzer out of hold.
Note: There are no alarm relays with this configuration. Current outputs are included with all configurations.
3. The Hold screen will then appear and **Hold will remain on indefinitely until Hold is disabled**.

See figure 5-1 below.

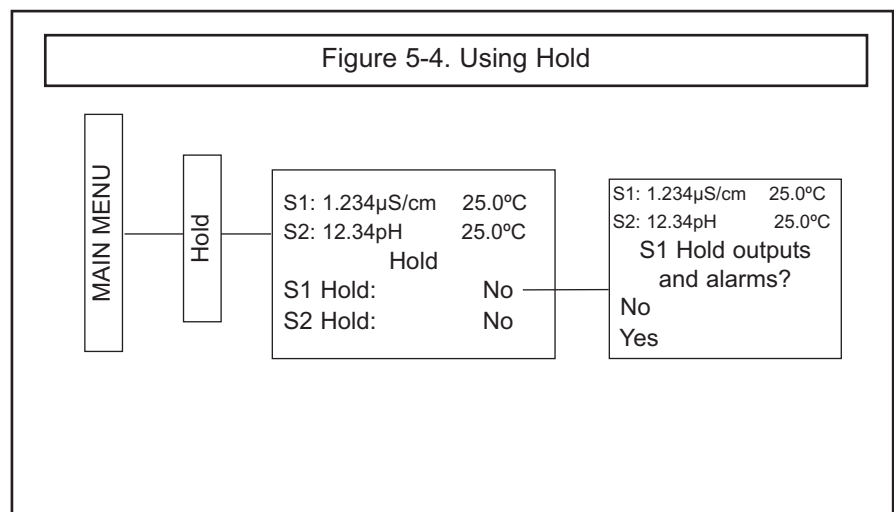

5.7 RESETTING FACTORY DEFAULT SETTINGS

5.7.1 Purpose.

This section describes how to restore factory calibration and default values. The process also clears all fault messages and returns the display to the first Quick Start screen. The Model 1056 offers three options for resetting factory defaults.

- a. reset all settings to factory defaults
- b. reset sensor calibration data only
- c. reset analog output settings only

5.7.2. Procedure.

To reset to factory defaults, reset calibration data only or reset analog outputs only, follow the Reset Analyzer flow diagram.

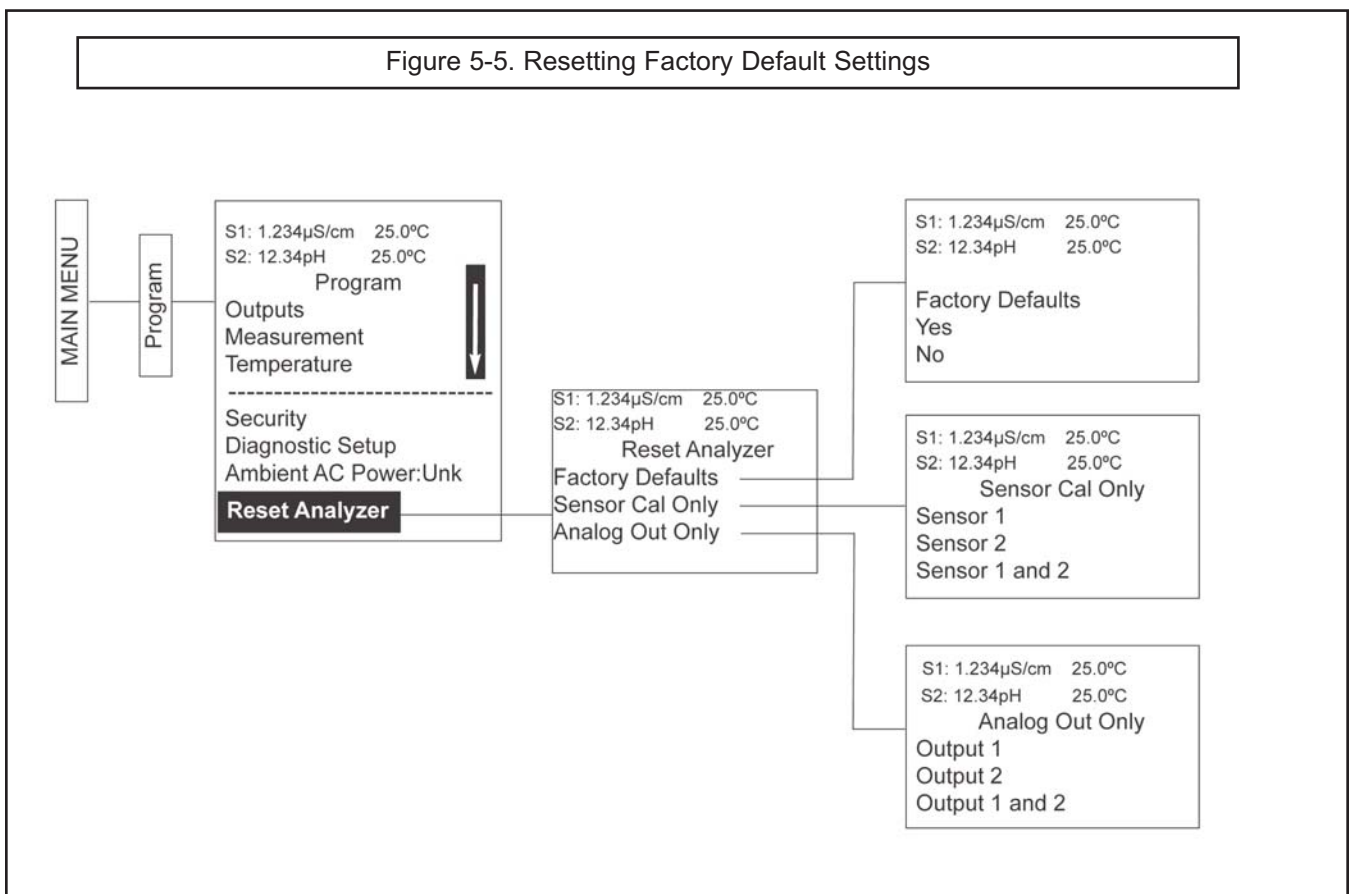

5.8 Programming Alarm Relays

5.8.1 Purpose.

The Model 1056 24VDC (-02 order code) and the AC switching power supply (-03 order code) provide four alarm relays for process measurement or temperature. Each alarm can be configured as a fault alarm instead of a process alarm. Also, each relay can be programmed independently and each can be programmed as an interval timer. This section describes how to configure alarm relays, simulate relay activation, and synchronize timers for the four alarm relays. This section provides details to program the following alarm features:

Sec.	Alarm relay feature:	default	Description
5.9.2	Enter Setpoint	100.0uS/cm	Enter alarm trigger value
5.9.3	Assign measurement	S1 Measure	Select alarm assignment
5.9.4	Set relay logic	High	Program relay to activate at High or Low reading
5.9.5	Deadband:	0.00uS/cm	Program the change in process value after the relay deactivates
5.9.6	Normal state:	Open	Program relay default condition as open or closed for failsafe operation
5.9.7	Interval time:	24.0 hr	Time in hours between relay activations
5.9.8	On-Time:	10 min	Enter the time in seconds that the relay is activated.
5.9.9	Recover time:	60 sec	Enter time after the relay deactivation for process recovery
5.9.10	Hold while active:	S1	Holds current outputs during relay activation
5.9.11	Simulate		Manually simulate alarms to confirm relay operation
5.9.12	Synchronize Timers	Yes	Control the timing of two or more relay timers set as Interval timers

Under the **Program/Alarms** menu, this screen will appear to allow configuration of the alarm relays. Follow the menu screens in Fig. XX to configure the outputs.

```
S1: 1.234µS/cm  25.0°C
S2: 12.34pH    25.0°C
Alarms
Configure/Setpoint
Simulate
Synchronize Timers: Yes
```

This screen will appear to allow selection of a specific alarm relay. Select the desired alarm and press ENTER.

```
S1: 1.234µS/cm  25.0°C
S2: 12.34pH    25.0°C
Configure/Setpoint
Alarm 1
Alarm 2
Alarm 3
Alarm 4
```

This screen will appear next to allow complete programming of each alarm. Factory defaults are displayed as they would appear for an installed contacting conductivity board. USP Safety only appears if alarm logic is set to "USP". Interval timer, On Time, Recover Time, and Hold While Active only appear if the alarm is configured as an Interval timer.

```
S1: 1.234µS/cm  25.0°C
S2: 12.34pH    25.0°C
AlarmM Settings
Setpoint: 100.0uS/cm
Assign: S1 Measure
Logic: High
Deadband: 0.00uS/cm
USP Safety: 0%↓
-----
Interval time: 24.0 hr
On Time: 120 sec
Recover time: 60 sec
Hold while active: Sens1
```

5.8.2 Procedure – Enter Setpoints

Under the Program/Alarms menu, this screen will appear to allow configuration of the alarm relays. Enter the desired value for the process measurement or temperature at which to activate an alarm event.

S1: 1.234µS/cm 25.0°C
S2: 12.34pH 25.0°C
Alarm1 S2 Setpoint
+100.0uS/cm

5.8.3 Procedure – Assign Measurement

Under the Alarms Settings menu, this screen will appear to allow assignment of the alarm relays. select an alarm assignment. Additional assignment choices are shown in Figure X-X depending on which measurement board(s) is installed.

S1: 1.234µS/cm 25.0°C
S2: 12.34pH 25.0°C
AlarmM Assign:
S1 Measurement
S2 Measurement
Interval Timer
Fault
Off

5.8.4 Procedure – Set Relay Logic

Under the Alarms Settings menu, this screen will appear to set the alarm logic. Select the desired relay logic to activate alarms at a High reading or a Low reading. USP Safety only appears if a contacting conductivity board is installed.

S1: 1.234µS/cm 25.0°C
S2: 12.34pH 25.0°C
AlarmM Logic:
High
Low
USP

5.8.5 Procedure – Deadband

Under the Alarms Settings menu, this screen will appear to program the deadband as a measurement value. Enter the change in the process value needed after the relay deactivates to return to normal (and thereby preventing repeated alarm activation).

S1: 1.234µS/cm 25.0°C
S2: 12.34pH 25.0°C
Alarm1 Deadband
+000.5uS/cm

5.8.6 Procedure – Normal state

The user can define failsafe condition in software by programming the alarm default state to normally open or normally closed upon power up. To display this alarm configuration item, enter the Expert menus by holding down the EXIT key for 6 seconds while in the main display mode. Select Yes upon seeing the screen prompt: “Enable Expert Menu?”

Under the Alarms Settings menu, this screen will appear to set the normal state of the alarms. Select the alarm condition that is desired each time the analyzer is powering up.

S1: 1.234µS/cm 25.0°C
S2: 12.34pH 25.0°C
Alarm2 Normal State
Open
Closed

5.8.7 Procedure – Interval time

Under the Alarms Settings menu, this screen will appear to set the interval time. Enter the fixed time in hours between relay activations.

S1: 1.234µS/cm 25.0°C
S2: 12.34pH 25.0°C
Alarm1 Interval Time
024.0 hrs

5.8.8 Procedure – On time

Under the Alarms Settings menu, this screen will appear to set the relay on time. Enter the time in seconds that the relay is activated.

S1: 1.234 μ S/cm 25.0 $^{\circ}$ C
S2: 12.34pH 25.0 $^{\circ}$ C
Alarm1 On-Time
00.00sec

5.8.9 Procedure – Recovery time

Under the Alarms Settings menu, this screen will appear to set the relay recovery time. Enter time after the relay deactivation for process recovery.

S1: 1.234 μ S/cm 25.0 $^{\circ}$ C
S2: 12.34pH 25.0 $^{\circ}$ C
Alarm1 Recovery
060sec

5.8.10 Procedure – Hold while active

Under the Alarms Settings menu, this screen will appear to program the feature that Holds the current outputs while alarms are active. Select to hold the current outputs for Sensor 1, Sensor 2 or both sensors while the relay is activated.

S1: 1.234 μ S/cm 25.0 $^{\circ}$ C
S2: 12.34pH 25.0 $^{\circ}$ C
Alarm1 Hold while active
Sensor 1
Sensor 2
Both
None

5.8.11 Procedure – Simulate

Alarm relays can be manually set for the purposes of checking devices such as valves or pumps. Under the Alarms Settings menu, this screen will appear to allow manual forced activation of the alarm relays. Select the desired alarm condition to simulate.

S1: 1.234 μ S/cm 25.0 $^{\circ}$ C
S2: 12.34pH 25.0 $^{\circ}$ C
Simulate Alarm *M*
Don't simulate
De-energize
Energize

5.8.12 Procedure – Synchronize

Under the Alarms Settings menu, this screen will appear to allow Synchronization of alarms that are set to interval timers. Select yes or no to Synchronize two or more timers.

S1: 1.234 μ S/cm 25.0 $^{\circ}$ C
S2: 12.34pH 25.0 $^{\circ}$ C
Synchronize Timers
Yes
No

SECTION 6.0

PROGRAMMING - TURBIDITY

6.1 CONFIGURING MEASUREMENTS – INTRODUCTION

6.2 TURBIDITY

6.3 CHOOSING TURBIDITY OR TOTAL SUSPENDED SOLIDS

6.4 ENTERING A TURBIDITY TO TSS CONVERSION EQUATION

6.1 PROGRAMMING MEASUREMENTS – INTRODUCTION

The Model 1056 automatically recognizes each installed measurement board upon first power-up and each time the analyzer is powered. Completion of Quick Start screens upon first power up enable measurements, but additional steps may be required to program the analyzer for the desired measurement application. This section covers the following programming and configuration functions;

1. Selecting measurement type or sensor type (all sections)
2. Defining measurement display units (all sections)
3. Adjusting the input filter to control display and output reading variability or noise (all sections)
4. Entering TSS data
5. Information on bubble rejection algorithm

To fully configure the analyzer for each installed measurement board, you may use the following:

1. Reset Analyzer function to reset factory defaults and configure the measurement board to the desired measurement. Follow the Reset Analyzer menu to reconfigure the analyzer to display new measurements or measurement units.
2. Program menus to adjust any of the programmable configuration items. Use the following configuration and programming guidelines for the applicable measurement.

6.2 TURBIDITY MEASUREMENT PROGRAMMING

6.2.1 DESCRIPTION

This section describes how to configure the Model 1056 analyzer for Turbidity measurements. The following programming and configuration functions are covered.

TABLE 6-11 TURBIDITY MEASUREMENT PROGRAMMING

Measure	Sec.	Menu function:	default	Description
Turbidity	6.9.2	Measurement type:	Turbidity	Select Turbidity or TSS calculation (estimated TSS)
	6.9.3	Measurement units:	NTU	NTU, FTU, FNU
	6.9.4	Enter TSS* Data:		Enter TSS and NTU data to calculate TSS based on Turbidity
	6.9.5	Filter:	20 sec	Override the default input filter, enter 0-999 seconds
	6.9.6	Bubble Rejection:	On	Intelligent software algorithm to eliminate erroneous readings caused by bubble accumulation in the sample

*TSS: Total Suspended Solids

A detailed flow diagram for Turbidity programming is provided at the end of Sec. 6 to guide you through all basic programming and configuration functions.

To configure the Turbidity measurement board:

1. Press MENU
2. Scroll down to Program. Press ENTER.
3. Scroll down to Measurement. Press ENTER.
4. Select Sensor 1 or Sensor 2 corresponding to Turbidity. Press ENTER.

S1: 1.234µS/cm	25.0°C
S2: 12.34pH	25.0°C
SN Configure	
Measure:	Turbidity
Units:	NTU
Enter TSS Data	
Filter:	20sec

Bubble Rejection:	On

The following screen format will appear (factory defaults are shown).

To program Turbidity, scroll to the desired item and press ENTER.

The following sub-sections provide you with the initial display screen that appears for each programming routine. Use the flow diagram for Turbidity programming at the end of Sec. 6 and the live screen prompts to complete programming.

6.2.2 Measurement

The display screen for selecting the measurement is shown. The default measurement is displayed in bold type. Refer to the Turbidity Programming flow diagram to complete this function.

S1: 1.234µS/cm	25.0°C
S2: 12.34pH	25.0°C
SN Measurement	
Turbidity	
Calculated TSS	

6.2.3 Units

The display screen for selecting the measurement units is shown. The default value is displayed in bold type. Refer to the Turbidity Programming flow diagram to complete this function.

S1: 1.234µS/cm	25.0°C
S2: 12.34pH	25.0°C
SN Units	
NTU	
FTU	
FNU	

If TSS data (Total Suspended Solids) calculation is selected, the following screen will be displayed. Refer to the Turbidity programming flow diagram to complete this function.

```
S1: 1.234µS/cm  25.0°C
S2: 12.34pH    25.0°C
                SN Units
ppm
mg/L
none
```

6.2.4 Enter TSS Data

The display screen for entering TSS Data is shown. The default values are displayed. Refer to the Turbidity Programming flow diagram to complete this function

```
S1: 1.234µS/cm  25.0°C
S2: 12.34pH    25.0°C
                SN TSS Data
Pt1 TSS:      0.000ppm
Pt1 Turbid:   0.000NTU
Pt2 TSS:      100.0ppm
Pt2 Turbid:   100.0NTU
-----
Calculate
```

Note: Based on user-entered NTU data, calculating TSS as a straight line curve could cause TSS to go below zero. The following screen lets users know that TSS will become zero below a certain NTU value.

```
S1: 1.234µS/cm  25.0°C
S2: 12.34pH    25.0°C
                SN TSS Data
Calculation Complete
Calculated TSS = 0 below
xxxx NTU
```

The following illustration shows the potential for calculated TSS to go below zero

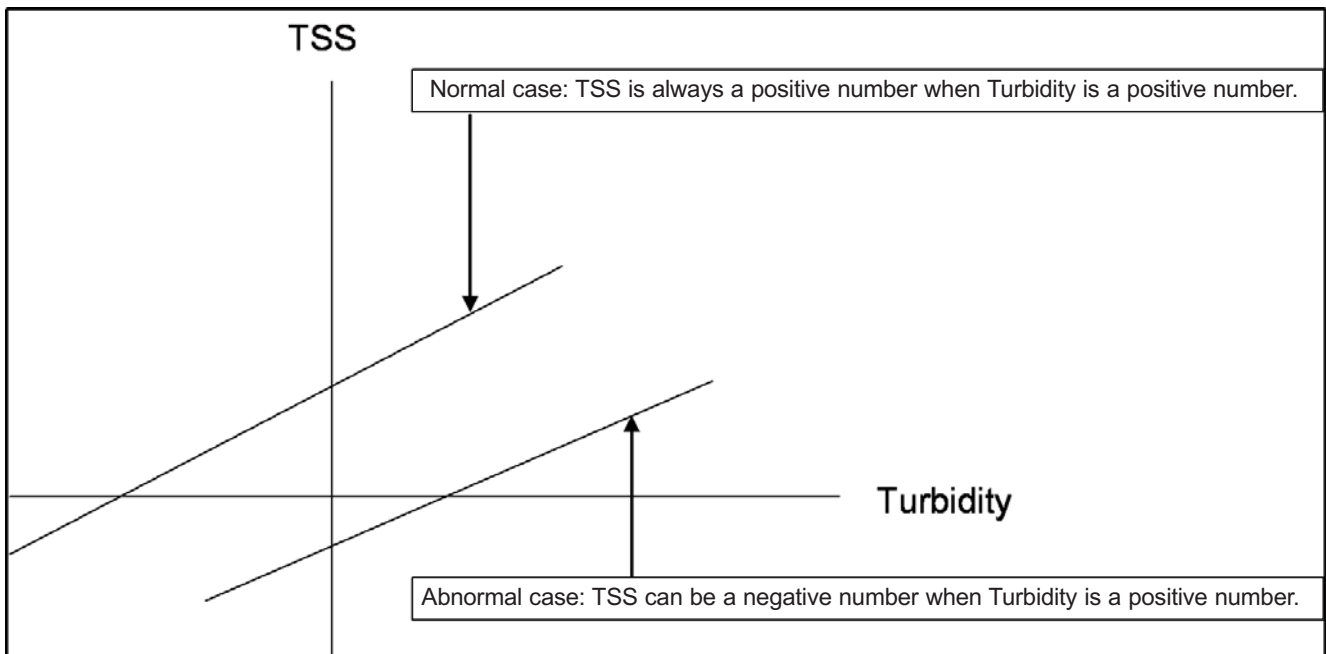

When the TSS data entry is complete, press ENTER. The display will confirm the determination of a TSS straight line curve fit to the entered NTU/turbidity data by displaying this screen:

```
S1: 1.234µS/cm  25.0°C
S2: 12.34pH    25.0°C
      SN TSS Data
      Calculation
      Complete
```

The following screen may appear if TSS calculation is unsuccessful. Re-entry of NTU and TSS data is required.

```
S1: 1.234µS/cm  25.0°C
S2: 12.34pH    25.0°C
      SN TSS Data
      Data Entry Error

      Press EXIT
```

6.2.5 Filter

The display screen for entering the input filter value in seconds is shown. The default value is displayed in bold type. Refer to the Turbidity Programming flow diagram to complete this function.

```
S1: 1.234µS/cm  25.0°C
S2: 12.34pH    25.0°C
      SN Input Filter
      020sec
```

6.2.6 Bubble Rejection

Bubble rejection is an internal software algorithm that characterizes turbidity readings as bubbles as opposed to true turbidity of the sample. With Bubble rejection enabled, these erroneous readings are eliminated from the live measurements shown on the display and transmitted via the current outputs.

```
S1: 1.234µS/cm  25.0°C
S2: 12.34pH    25.0°C
      SN Bubble Rejection
      On
      Off
```

The display screen for selecting bubble rejection algorithm is shown. The default setting is displayed in bold type. Refer to the Turbidity Programming flow diagram to complete this function.

6.3 CHOOSING TURBIDITY OR TOTAL SUSPENDED SOLIDS

6.3.1 Purpose

This section describes how to do the following:

1. Configure the analyzer to display results as turbidity or total suspended solids (TSS).
2. Choose units in which results are to be displayed.
3. Select a time period for signal averaging.
4. Enable or disable bubble rejection software.

6.3.2 Definitions

1. **TURBIDITY.** Turbidity is a measure of the amount of light scattered by particles in a sample. Figure 6-4 illustrates how turbidity is measured. A beam of light passes through a sample containing suspended particles. The particles interact with the light and scatter it in all directions. Although the drawing implies scattering is equal in all directions, this is generally not the case. For particles bigger than about 1/10 of the wavelength of light, scattering is highly directional. A detector measures the intensity of scattered light.

Measured turbidity is dependent on instrumental conditions. In an attempt to allow turbidities measured by different instruments to be compared, two standards for turbidity instruments have evolved. USEPA established Method 180.1, and the International Standards Organization established ISO 7027. EPA Method 180.1 must be used for reporting purposes in the United States. Figure 6-5 shows an EPA 180.1 turbidimeter. Figure 6-6 shows an ISO 7027 turbidimeter.

EPA Method 180.1 requires that:

- A. The light source be a tungsten lamp operated with a filament temperature between 2200 and 2700 K.
- B. The detector have optimum response between 400 and 600 nm (approximates the human eye).
- C. The scattered light be measured at $90^{\circ} \pm 30^{\circ}$ with respect to the incident beam.
- D. The total path length of the light through the sample be less than 10 cm.

Requirements A and B essentially restrict the measurement to visible light. Although the most of the energy radiated by an incandescent lamp is in the near infrared, keeping the filament temperature between 2200 and 2700 K, ensures that at least some energy is available in the visible range. Further specifying that the detector and filter combination have maximum sensitivity between 400 nm (violet light) and 600 nm (orange light), cements the measurement in the visible range. Wavelength is important because particles scatter light most efficiently if their size is approximately equal to the wavelength of light used for the measurement. The longer the wavelength, the more sensitive the measurement is to larger diameter particles and the less sensitive it is to smaller diameter particles.

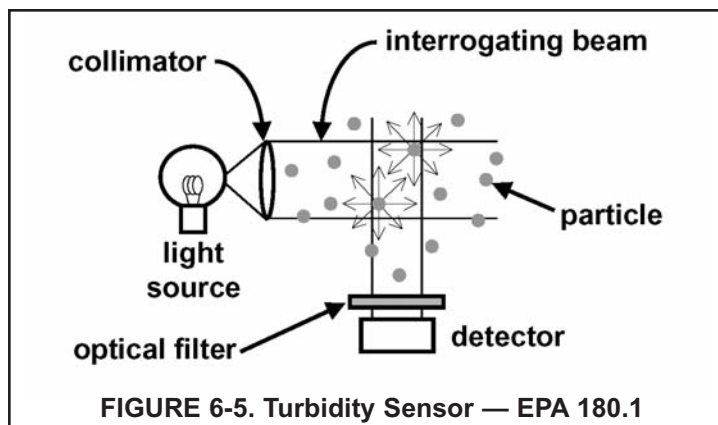
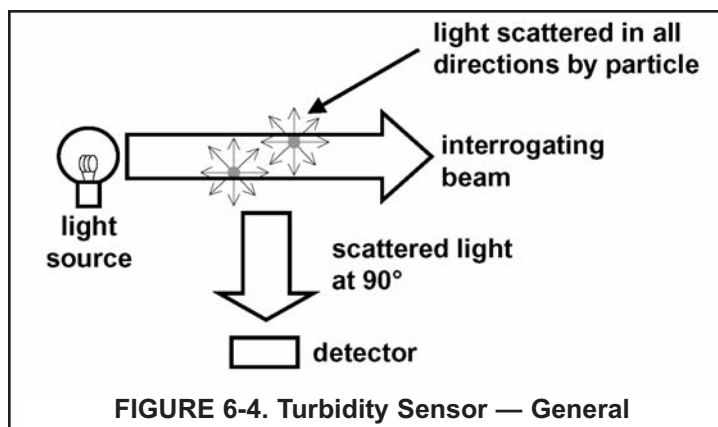

continued on following page

Requirement C is arbitrary. The light scattered by a particle depends on the shape and size of the particle, the wavelength used for the measurement, and the angle of observation. Choosing 90° avoids the difficulties of having to integrate the scattered light over all the scattering angles. An arbitrary observation angle works so long as the sample turbidity is referred to the turbidity of a standard solution measured at the same angle. A turbidimeter that measures scattered light at 90° is called a nephelometer.

Requirement D has a lot to do with the linearity of the sensor. As Figures 6-5 and 6-6 show, particles lying between the measurement zone and the detector can scatter the scattered radiation. This secondary scattering reduces the amount of light striking the detector. The result is a decrease in the expected turbidity value and a decrease in linearity. The greater the amount of secondary scattering, the greater the non-linearity. Particles in the area between the source and measurement zone also reduce linearity.

ISO 7027 requirements are somewhat different from EPA requirements. ISO 7027 requires that:

- A. The wavelength of the interrogating light be $860\pm 60\text{nm}$, or for colorless samples, $550\pm 30\text{nm}$.
- B. The measuring angle be $90\pm 2.5^\circ$.

ISO 7027 does not restrict the maximum light path length through the sample. ISO 7027 calls out beam geometry and aperture requirements that EPA 180.1 does not address.

Although ISO 7027 allows a laser, light emitting diode, or tungsten filament lamp fitted with an interference filter as the light source, most instruments, including the Clarity II, use an 860 nm LED. Because ISO 7027 turbidimeters use a longer wavelength for the measurement, they tend to be more sensitive to larger particles than EPA 180.1 turbidimeters. Turbidities measured using the EPA and ISO methods will be different.

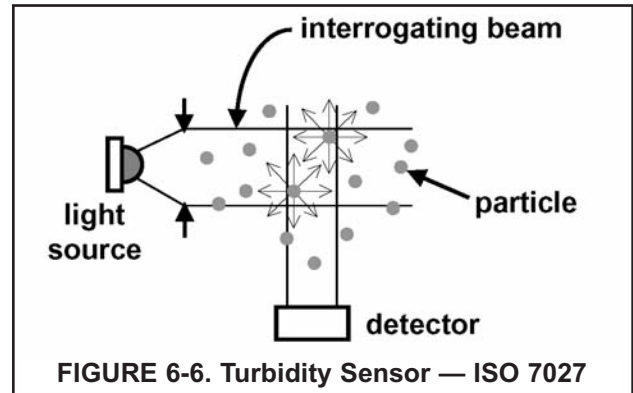

FIGURE 6-6. Turbidity Sensor — ISO 7027

2. **TOTAL SUSPENDED SOLIDS.** Total suspended solids (TSS) is a measure of the total mass of particles in a sample. It is determined by filtering a volume of sample and weighing the mass of dried residue retained on the filter. Because turbidity arises from suspended particles in water, turbidity can be used as an alternative way of measuring total suspended solids (TSS). The relation between turbidity and TSS is wholly empirical and must be determined by the user.
3. **TURBIDITY UNITS.** Turbidity is measured in units of NTU (nephelometric turbidity units), FTU (formazin turbidity units), or FNU (formazin nephelometric units). Nephelometry means the scattered light is measured at 90° to the interrogating beam. Formazin refers to the polymer suspension typically used to calibrate turbidity sensors. The units — NTU, FTU, and FNU — are equivalent.
4. **TSS UNITS.** The TSS value calculated from the turbidity measurement can be displayed in units of ppm or mg/L. The user can also choose to have no units displayed.
5. **SIGNAL AVERAGING.** Signal averaging is a way of filtering noisy signals. Signal averaging reduces random fluctuation in the signal but increases the response time to step changes. Recommended signal averaging is 20 sec. The reading will take 20 seconds to reach 63% of its final value following a step change greater than the filter threshold.
6. **BUBBLE REJECTION.** When a bubble passes through the light beam, it reflects light onto the measuring photodiode, causing a spike in the measured turbidity. The Model 1056 analyzer has proprietary software that rejects the turbidity spikes caused by bubbles.

6.3.3 Procedure: Selecting Turbidity or TSS

To choose a menu item, move the cursor to the item and press ENTER.
To store a number or setting, press ENTER.

1. Press MENU. The main menu screen appears. Choose **Program**.
2. Choose **Measurement**.
3. Choose **Sensor 1** or **Sensor 2**. For a single input configuration, the **Sensor 1 Sensor 2** screen does not appear.
4. Choose **Turbidity** or **TSS**.
5. Choose the desired units:
 - a. For turbidity choose **NTU**, **FTU**, or **FNU**.
 - b. For TSS choose **ppm**, **mg/L**, or **none**.
6. Choose **Bubble Rejection**.
7. Choose **On** to enable bubble rejection software. Choose **Off** to disable.
8. Press EXIT to return to the previous screen. To return to the main display, press MENU followed by EXIT.

6.4 ENTERING A TURBIDITY TO TSS CONVERSION EQUATION

6.4.1 Purpose

The analyzer can be programmed to convert turbidity to a total suspended solids (TSS) reading. There is no fundamental relationship between turbidity and TSS. Every process stream is unique. The user must determine the relationship between turbidity and TSS for his process. The analyzer accepts only a linear calibration curve.

Figure 6-2 shows how the turbidity to TSS conversion works. The user enters two points P1 and P2, and the analyzer calculates the equation of a straight line between the points. The analyzer then converts all subsequent turbidity measurements to TSS using the equation. It is important to note that if the cause or the source of the turbidity changes, new points P1 and P2 will need to be determined and the calibration repeated.

The accuracy of the measurement depends on how linear the actual relationship between TSS and turbidity is. At a minimum, the user should confirm linearity by diluting the most turbid sample (P2) and verifying that the new turbidity and TSS point lies reasonably close to the line. Ideally, the dilution should be done with filtered sample, not deionized water. Deionized water can change the index of refraction of the liquid and can increase or decrease the solubility of the particles. Therefore, the diluted sample will not be representative of the process liquid. For a more rigorous procedure for checking linearity and developing values to enter for points P1 and P2, refer to the Appendix.

After the analyzer has calculated the turbidity to TSS conversion equation, it also calculates the x-intercept (NTU). See Figure 6-3. If the x-intercept is greater than zero, the analyzer will display that value as the lowest turbidity reading it will accept. A lower turbidity reading will produce a negative TSS value. If the x-intercept is less than zero, the screen does not appear.

6.4 ENTERING A TURBIDITY TO TSS CONVERSION EQUATION cont.

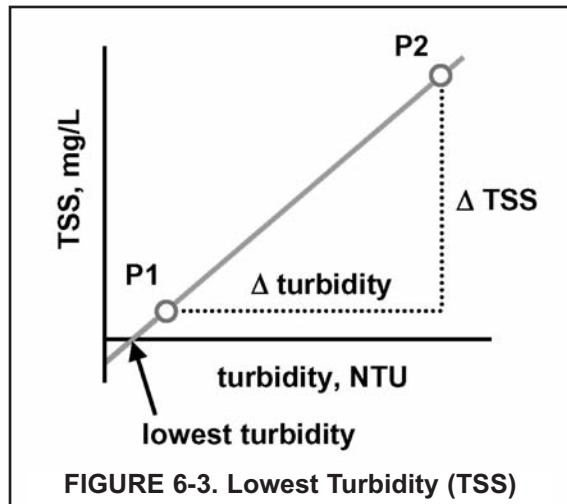
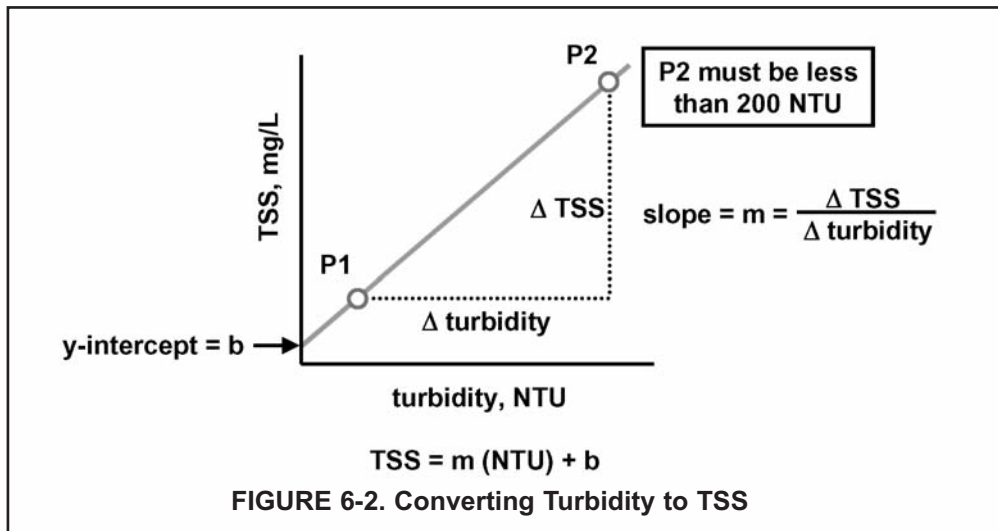

6.4.2 Procedure

1. First, calibrate the sensor. See Section Section 6.2, 6.3, or 6.4.
2. Press the MENU key. The main menu appears. Choose **Program**.
3. Choose **Measurement**
4. Choose **Sen1** (sensor 1) or **Sen2** (sensor 2).
5. Choose **Enter TSS Data**.
6. The display prompts the user to enter TSS for point 1 (**Pt1**). The units shown in the second line will be the units selected in Section 5.5.3. Press ENTER.
7. The display prompts the user to enter the turbidity for point 1. Press ENTER.
8. The display prompts the user to enter TSS for point 2 (**Pt2**). Press ENTER.
9. The display prompts the user to enter the turbidity for point 2. Press ENTER.
10. The screen at left appears if the calibration was successful. Press ENTER.
11. If the calibration was unsuccessful, repeat steps 6 through 9, checking for data entry errors.
12. If the intercept on the NTU axis is negative, the analyzer will display the low turbidity limit.
13. To return to the main display, press MENU then EXIT.

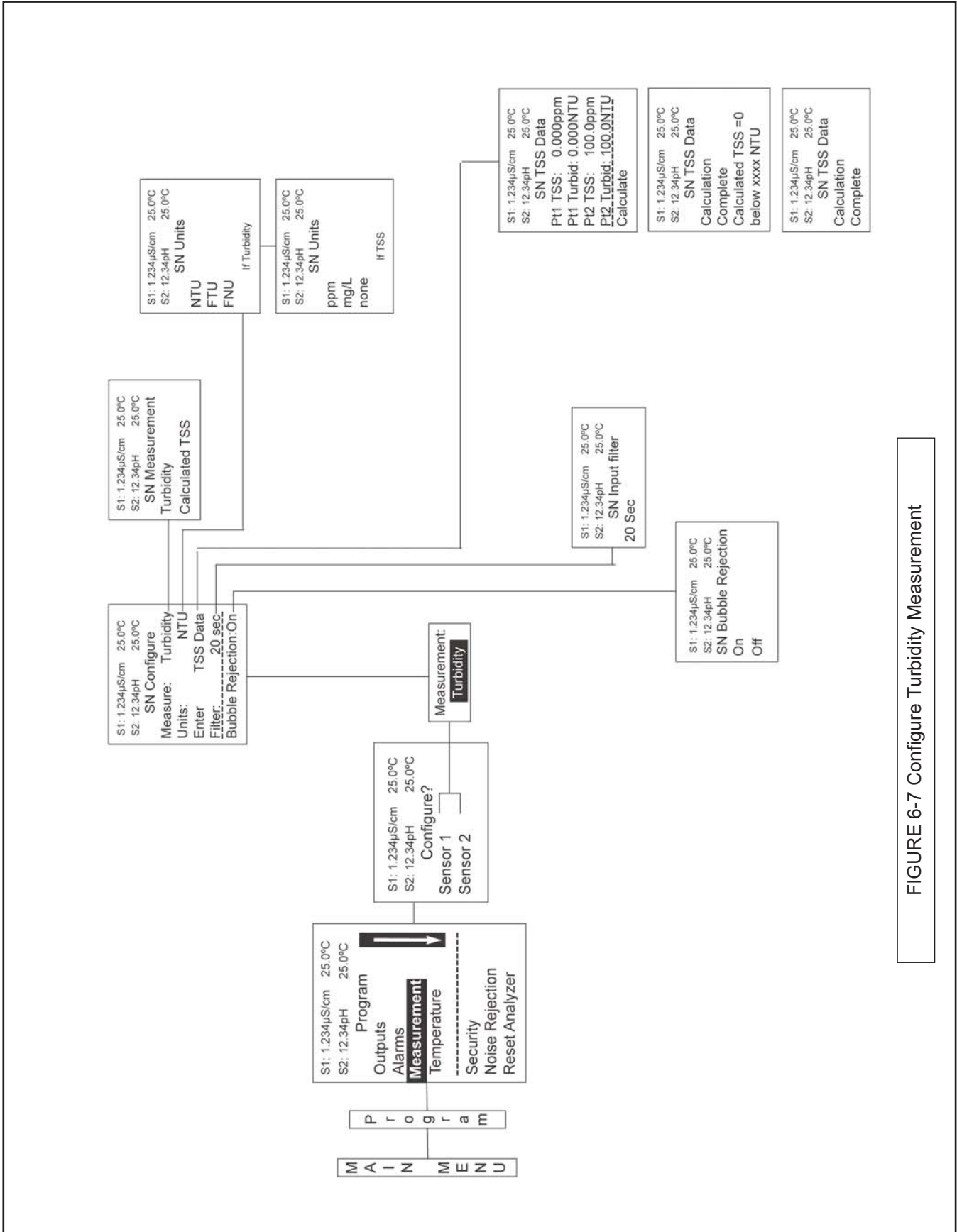

FIGURE 6-7 Configure Turbidity Measurement

SECTION 7.0 CALIBRATION

7.1 CALIBRATION – INTRODUCTION

7.2 TURBIDITY CALIBRATION

7.1 CALIBRATION – INTRODUCTION

Calibration is the process of adjusting or standardizing the analyzer to a lab test or a calibrated laboratory instrument, or standardizing to some known reference (such as a commercial buffer).

The auto-recognition feature of the analyzer will enable the appropriate calibration screens to allow calibration for

any single sensor configuration or dual sensor configuration of the analyzer. Completion of Quick Start upon first power up enables live measurements but does not ensure accurate readings in the lab or in process. Calibration should be performed with each attached sensor to ensure accurate, repeatable readings.

7.2 TURBIDITY CALIBRATION

7.2.1 DESCRIPTION

This section describes how to calibrate the turbidity sensor against a user-prepared standard as a 2-point calibration with di-ionized water, against a 20 NTU user-prepared standard as a single point calibration, and against a grab sample using a reference turbidimeter.

THIS SECTION DESCRIBES HOW TO CALIBRATE THE MODEL 1056 WITH AN ATTACHED TURBIDITY SENSOR AS PART OF THE COMPLETE CLARITY II TURBIDITY SYSTEM. THE FOLLOWING CALIBRATION ROUTINES ARE COVERED.

TABLE 7-12 TURBIDITY CALIBRATION ROUTINES

Measure	Sec.	Calibration function:	default value	Description
Turbidity	7.10.2	Slope Calibration		Slope cal with pure water and a standard of known turbidity
	7.10.3	Standardize Calibration		Standardizing the sensor to a known turbidity
	7.10.4	Grab Calibration		Standardizing the sensor to a known turbidity based on a reference turbidimeter

A detailed flow diagram is provided at the end of Sec. 7 to guide you through the calibration routines.

To calibrate Turbidity:

1. Press the **MENU** button
2. Select **Calibrate**. Press ENTER.
3. Select **Sensor 1** or **Sensor 2** corresponding to Turbidity. Press ENTER.
4. Select **Turbidity**. Press ENTER.

The following screen will appear.

```
S1: 1.234µS/cm  25.0°C
S2: 12.34pH    25.0°C
      SN Calibrate?
Turbidity
```

The following sub-sections provide you with the initial display screen that appears for each calibration routine. Use the **flow diagram for Turbidity calibration** at the end of Sec. 7 and the live screen prompts to complete calibration.

```
S1: 1.234µS/cm  25.0°C
S2: 12.34pH    25.0°C
      SN Calibrate
Slope
Standard
Grab
```

7.2.2 SLOPE CALIBRATION — Turbidity

This section describes how to conduct a 2-point calibration of the turbidity sensor against a user-prepared 20NTU standard. The calibration requires two steps. First, immerse the sensor in filtered water having very low turbidity and measure the sensor output. Next, increase the turbidity of the filtered water by a known amount, typically 20 NTU, and measure the sensor output again. The analyzer takes the two measurements, applies a linearization correction (if necessary), and calculates the sensitivity. Sensitivity is the sensor output (in mV) divided by turbidity. A typical new sensor has a sensitivity of about 10 mV/NTU. As the sensor ages, the sensitivity decreases. The figure below illustrates how turbidity calibration works. Before beginning the calibration, the analyzer does a dark current measurement. Dark current is the signal generated by the detector when no light is falling on it. The analyzer subtracts the dark current from the raw scat-

tered light signal and converts the result to turbidity. In highly filtered samples, which scatter little light, the dark current can be a substantial amount of the signal generated by the detector.

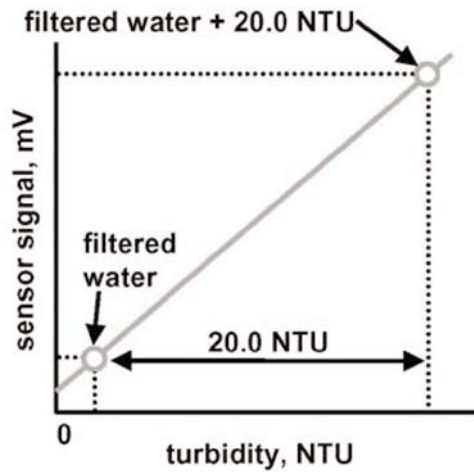

This screen appears after selecting Slope calibration.

```
S1: 1.234µS/cm  25.0°C
S2: 12.34pH    25.0°C
                SN Slope Cal
Sensor in pure H2O?
Press ENTER
```

The following screen will appear if Slope Cal is successful. The screen will return to the Turbidity Cal Menu.

```
S1: 1.234µS/cm  25.0°C
S2: 12.34pH    25.0°C
                SN Slope Cal
                Cal Complete
```

The following screen may appear if Slope Cal is unsuccessful.

```
S1: 1.234µS/cm  25.0°C
S2: 12.34pH    25.0°C
                SN Slope Cal
                Calibration
                Error
                Press EXIT
```

7.2.3 STANDARDIZE CALIBRATION - Turbidity

The turbidity sensor can also be calibrated against a commercial standard. Stable 20.0 NTU standards are available from a number of sources. Calibration using a commercial standard is simple. Filtered deionized water is not required. Before beginning the calibration, the analyzer does a dark current measurement. Dark current is the signal generated by the detector even when no light is falling on it. The analyzer subtracts the dark current from the raw scattered light signal and converts the result to turbidity. In highly filtered samples, which scatter little light, the dark current can be a substantial amount of the signal generated by the sensor.

The following screen will appear if Standard Cal is successful. The screen will return to the Turbidity Cal Menu.

The following screen may appear if Standard Cal is unsuccessful.

7.2.4 GRAB CALIBRATION - Turbidity

If desired, the turbidity sensor can be calibrated against the turbidity reading from another instrument. The analyzer treats the value entered by the user as though it were the true turbidity of the sample. Therefore, grab sample calibration changes the sensitivity, it does not apply an offset to the reading.

The following screen will appear if Grab Cal is successful. The screen will return to the Turbidity Cal Menu.

The following screen may appear if Grab Cal is unsuccessful.

This screen appears after selecting **Standard calibration**.

```
S1: 1.234µS/cm  25.0°C
S2: 12.34pH    25.0°C
      SN Standard Cal
Sensor in Standard?
Press ENTER
```

```
S1: 1.234µS/cm  25.0°C
S2: 12.34pH    25.0°C
      SN Standard Cal
Cal Complete
```

```
S1: 1.234µS/cm  25.0°C
S2: 12.34pH    25.0°C
      SN Standard Cal
Calibration
Error
Press EXIT
```

This screen appears after selecting **Grab calibration**.

```
S1: 1.234µS/cm  25.0°C
S2: 12.34pH    25.0°C
      SN Grab Cal
Wait for stable
reading
```

```
S1: 1.234µS/cm  25.0°C
S2: 12.34pH    25.0°C
      SN Grab Cal
Cal Complete
```

```
S1: 1.234µS/cm  25.0°C
S2: 12.34pH    25.0°C
      SN Grab Cal
Calibration
Error
Press EXIT
```

FIGURE 7-8 Calibrate Turbidity

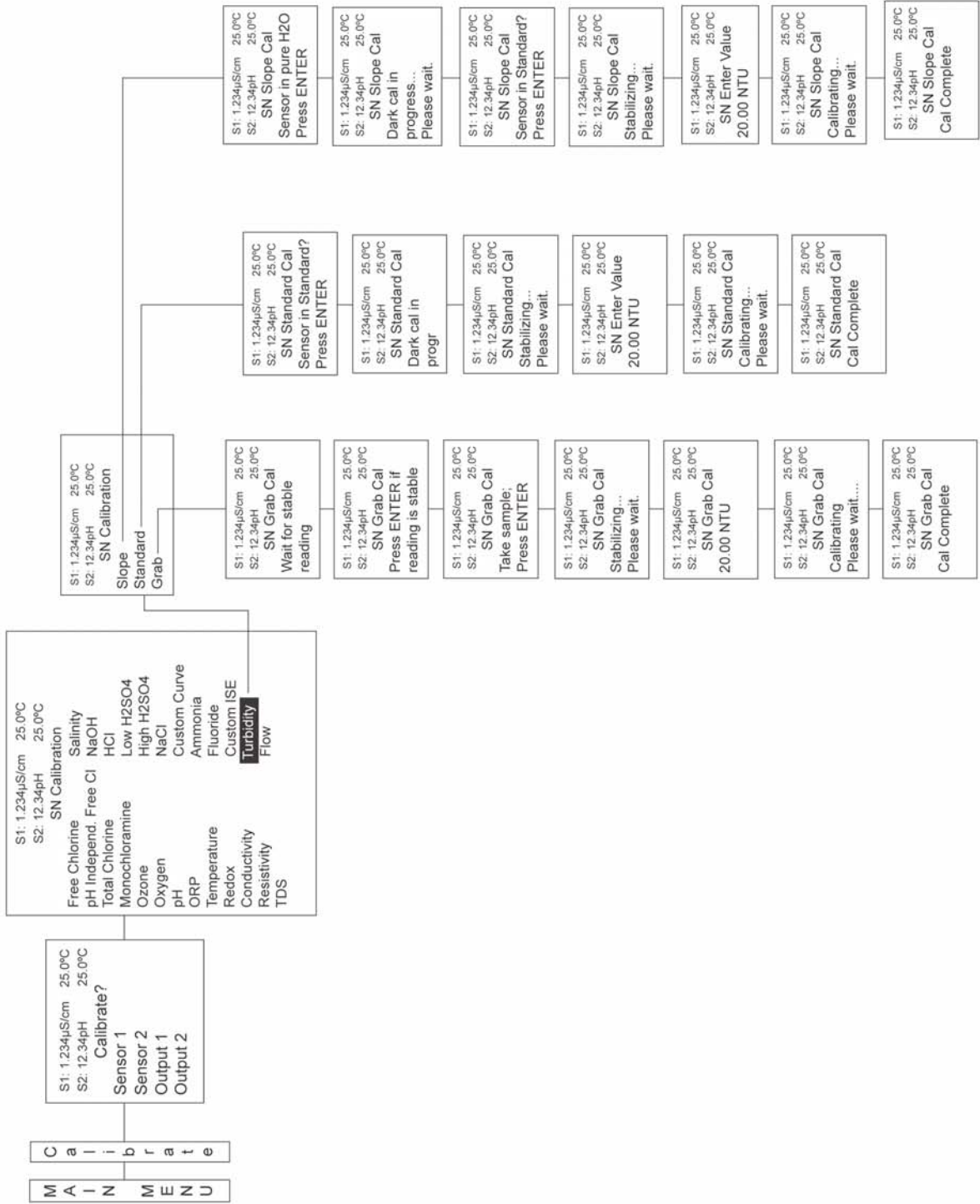

SECTION 8.0 MAINTENANCE

8.1 MODEL 1056

The Model 1056 analyzer used in the Clarity II turbidimeter needs little routine maintenance.

Clean the analyzer case and front panel by wiping it with a clean soft cloth dampened with water ONLY. Do not use solvents, like alcohol, that might cause a buildup of static charge.

A few of the components of the analyzer are replaceable. See Tables 8-1 and 8-2.



WARNING

Explosion Hazard. Do not disconnect equipment when a flammable or combustible atmosphere is present.

TABLE 8-1. Replacement Parts for Model 1056

PN	Description	Shipping Weight
23823-00	Panel mounting kit, includes four brackets and four set screws	2 lb/1.0 kg
34059-00	Gasket, for panel mounting	1 lb/0.5 kg
34062-00	Gasket, internal for enclosure	1 lb/0.5 kg
24230-00	Hole plug and gland fittings.	2 lb/1.0 kg

Shipping weights are rounded up to the nearest whole lb or 0.5 kg.

8.2 SENSOR

8.2.1 Cleaning the sensor

Clean the sensor by rinsing it with water followed by wiping with a soft tissue. If water is inadequate, wash with a mild detergent solution followed by thorough rinsing with water. **Do not scratch the lamp or photodiode windows.**

If mineral scale is present, use a dilute acid solution applied with a cotton swab to clean away the deposit. Rinse thoroughly with water.

Do not use abrasive cleaners or solvents.

8.2.2 Replacing the lamp/LED board

The USEPA-compliant sensor uses a tungsten filament lamp (PN 1-0901-0004-EPA) as the light source. The lamp has an expected life of about one year. The ISO-compliant version uses an infrared LED (PN 1-0901-0005-ISO). Its expected life is five years. The Model 1056 analyzer continuously monitors the source intensity and corrects for changes in source intensity caused by age. When the source intensity becomes too low, the analyzer warns the user. The user should replace the lamp as soon as possible.

To replace the lamp/LED board...

1. Turn off power to the analyzer.



WARNING!

Explosion hazard. Do not disconnect equipment when a flammable or combustible atmosphere is present.

2. Remove the sensor from the measuring chamber and disconnect the cable.



CAUTION

BEFORE REMOVING THE SENSOR, be absolutely certain the process pressure is reduced to 0 psig and the process temperature is at a safe level.



NOTE

If you have a dual input analyzer, you can reapply power at this point. The initial reading from the other sensor will be momentarily zero. After about 60 seconds the reading will reach its final value.

3. Using a small Phillips screwdriver, remove the two screws holding the top flange of the sensor to the body.
4. Using a slight back and forth twisting motion **carefully** pull the flange from the sensor body. You are pulling against a single O-ring seal. Don't pull too hard.
5. Using your thumb and forefinger, remove the lamp/LED circuit board from the sensor.
6. Insert the replacement board in the sensor and push the socket on the replacement board into the mating pins in the sensor.
7. Place the desiccant package in the sensor body.
8. Orient the flange so that the screw holes line up with the holes in the sensor body. Push the flange back on the sensor body and replace the screws. Don't let wires push on lamp board. It may be necessary to turn the flange a small amount until the holes line up.

step 4



step 5

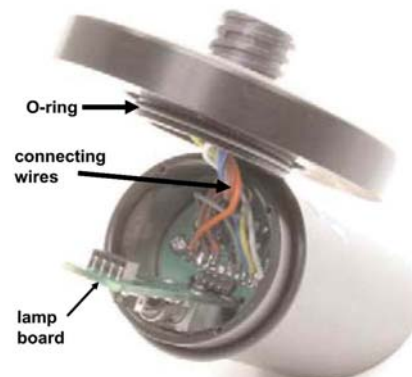

step 6



FIGURE 8-3. Replacing the Lamp/LED Board

- Place the sensor in the calibration cup and reconnect the cable.
- Calibrate the sensor using either slope or standard calibration (Section 6.2 or 6.3). Do not use grab calibration. Failure to calibrate the sensor may reduce the life of the sensor. See Sections 8.2.5 and 8.2.6.

8.3 DEBUBBLER AND MEASURING CHAMBER

8.3.1 Cleaning the debubbler and measuring chamber

- Turn off the sample supply to the debubbler.



- Remove the sensor and put it in a safe place. The calibration cup is a good place to store the sensor.
- Loosen the small drain plug in the base plug and allow the sample in the debubbler to drain out. See Figure 8-4. Replace the drain plug.
- Unscrew the upper and lower caps. Be careful not to lose the O-rings.
- Use a stream of water, a brush, or a rag to flush and clean out the inside of the debubbler and measuring chamber.
- Inspect the O-rings for signs of damage and replace if necessary. The part number for the O-ring (one each) is 9550316.
- Replace the upper and lower caps.
- Replace the sensor.

8.3.2 Cleaning the orifice

- Turn off the sample to the debubbler.
- Disconnect the drain line. Unscrew the drain fitting from the orifice; then unscrew the orifice from the debubbler body. See Figure 8-4.
- Use a stream of water to flush out any residue accumulated in the orifice. Direct the stream of water counter to the normal flow through the orifice.
- If the material plugging the orifice cannot be removed with flushing, use a toothpick or a stiff wire to push out the obstruction. Push counter to the normal flow through the orifice.
- Reinstall the orifice and reconnect the drain line. Turn on the sample flow.
- If the blockage cannot be removed or the orifice is damaged during cleaning, replace the orifice (PN 33947-00).

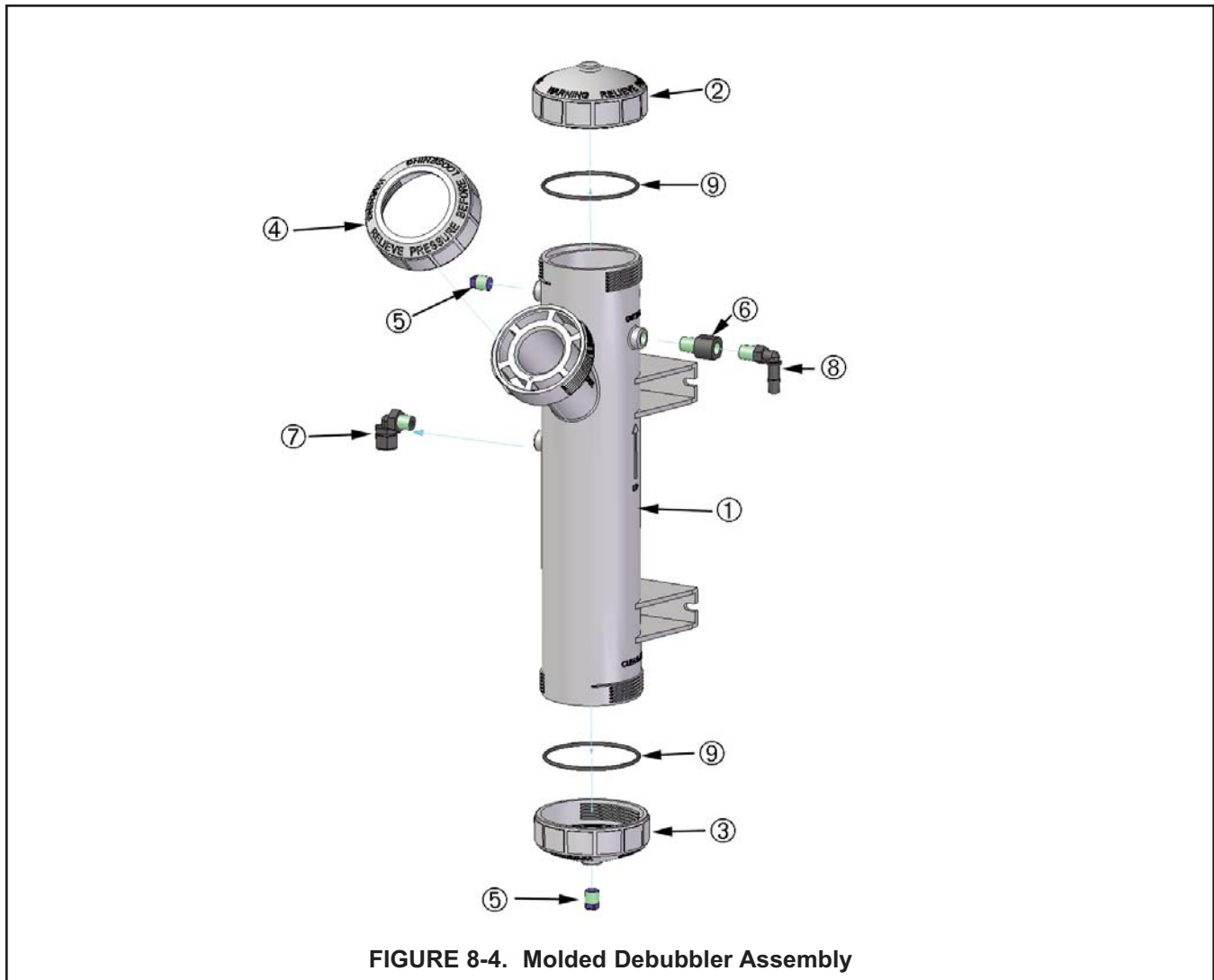

8.4 LIST OF REPLACEMENT PARTS

LOCATION IN FIGURE 8-4	DESCRIPTION	PART NUMBER
—	Replacement lamp board assembly, USEPA-compliant sensor	1-0901-0009-EPA
—	Replacement lamp board assembly, ISO-compliant sensor	1-0901-0010-ISO
—	Replacement sensor, USEPA-compliant	8-0108-0002-EPA
—	Replacement sensor, ISO-compliant	8-0108-0003-ISO
1	Debubbler housing	34015-00
2	Upper cap for debubbler	34014-00
3	Lower cap for debubbler	34014-01
4	Sensor nut	34014-02
5	Pipe plug, 1/4 inch MNPT (2 places)	3000854
6	Orifice assembly	33947-00
7	Sample inlet elbow, 1/4 in compression fitting x 1/4 in MNPT	9321010
8	Sample drain elbow, 3/8 in barb x 1/4 in MNPT	9322036
9	O-ring, one each, for upper and lower caps	9550322
not shown	O-ring, one each, for sensor	9550145

SECTION 9.0 TROUBLESHOOTING

9.1 OVERVIEW

The Model 1056 analyzer used in the Clarity II turbidimeter continuously monitors itself and the sensor for problems. When the analyzer detects a problem, the word fault or warning followed by *s* appears in the display alternately with the measurement. If alarm 3 was configured as a fault alarm and a fault has occurred, the relay will energize. The outputs do not change during a fault or warning condition. They continue to reflect the measured turbidity or TSS value.

To read fault and warning messages, go to the main display and press *s*. The analyzer will automatically scroll through the messages and will continue to scroll through the messages for two minutes. After two minutes the display will return to the default screen.

To stop the automatic scrolling and return to the main display, press EXIT.

Error messages are prefaced by the word fault or warning.

Faults are conditions requiring immediate attention from the user. Measurements made by the analyzer should be regarded as being in error.

Warnings are less serious than faults. A warning signifies the existence of a condition requiring attention. The instrument remains usable.

WARNING

Explosion hazard. Do not disconnect equipment when a flammable or combustible atmosphere is present.

9.2 TROUBLESHOOTING USING FAULT CODES

Fault message	Explanation	Section
SN Lamp/LED Failure	Lamp or LED is burned out	9.2.1
EEPROM Failure	Cannot save data to non-volatile memory	9.2.2
Factory Failure	Needs factory calibration	9.2.3

Warning message	Explanation	Section
SN Need Cal	Lamp intensity is weak but can be improved by calibrating	9.2.4
SN Weak Lamp	Weak lamp, replace as soon as possible	9.2.5
SN Warning	Poor sensor cable connection or unusual ambient light condition affecting sensor or sensor not immersed.	9.2.6

SN identifies the sensor affected. S1 is sensor 1; S2 is sensor 2.

9.2.1 Lamp/LED Failure

The light source in a Clarity II turbidity sensor can be either a tungsten filament lamp or an LED. USEPA-compliant sensors use a tungsten lamp. ISO-compliant sensors use an LED. A photodiode inside the sensor continuously monitors the intensity of the light source. The source intensity measurement is used to correct for source drift, which allows the sensor to operate for longer periods without calibration. If the signal from the photodiode drops below a certain value, the analyzer assumes the light source has either failed completely or the intensity is too low to be useful. At this point the analyzer displays the *Lamp Failure* message.

Replace the lamp or LED board. See Section 7.2.2.

After replacing the lamp board, be sure to recalibrate the sensor using either slope or standard calibration. See Section 6.2 or 6.3. Recalibration is necessary to reset the lamp power supply. Grab calibration will not reset the power supply and may result in significantly reduced lamp life.

9.2.2 EEPROM Failure

EEPROM failure means the analyzer is unable to store data in the non-volatile memory. Thus, if power is lost then restored, all configurations and calibrations will be lost. Call the factory for assistance. The analyzer will probably need to be replaced.

9.2.3 Factory Failure

Factory failure means the factory calibrations have been corrupted. Call the factory for assistance. The analyzer will probably need to be replaced.

9.2.4 Need Cal

The Clarity II sensor contains two photodiodes. One measures the intensity of the light scattered by the sample. The other measures the intensity of the lamp. Because turbidity is proportional to the intensity of light falling on the sample photodiode, any reduction of the lamp intensity will be measured as a decrease in turbidity even though the true turbidity remained constant. The analyzer uses the lamp intensity measurement to correct for changes in apparent turbidity caused by reduction of lamp intensity. However, if the lamp intensity gets too low, the correction may not be valid. At this point the analyzer displays the **Need Cal** warning. Calibrating will cause the analyzer to increase the current supplied to the lamp, thus increasing the lamp intensity.

- A. Calibrate the sensor using slope (Section 6.2), standard (Section 6.3), or lamp calibration (Section 6.5). Using slope or standard calibration is strongly recommended. Use lamp calibration ONLY if a turbidity standard is not available.
- B. If a replacement lamp board is not available, order one as soon as possible.

9.2.5 Weak Lamp

The Weak Lamp warning appears when lamp intensity is low and the current being supplied to the lamp (see Section 8.2.5) has been increased above a level likely to significantly reduce lamp life.

Replace the lamp board as soon as possible. After you replace the lamp, recalibrate the sensor using either slope or standard calibration. See Section 6.2 or 6.3. Recalibration is necessary to reset the lamp power supply. Grab calibration will not reset the power supply. Failure to recalibrate using slope or standard calibration may significantly reduce lamp life.

9.2.6 SN Warning

“SN Warning” will be displayed on the instrument to communicate an unusual but non-fatal condition that may require checking and adjustments. Check three things.

- A. Check the sensor/cable connection. Confirm that the swivel nut on the cable is in the locked position on the sensor. Note: Once the plastic threaded swivel nut is engaged with the sensor threads, rotate the swivel 3/4 turn to lock the cable to the sensor.
- B. Confirm that sample water is flowing out of the debubbler drain outlet. This ensures that the sensor is immersed in sample water.
- C. Ensure that the sensor is not exposed to high ambient light sources (such as direct sunlight).

IMPORTANT NOTE:

When using EPA/incandescent sensors (PN 8-0108-0002-EPA):

- n DO NOT power up the instrument without the sensor connected
- n DO NOT disconnect and reconnect a sensor while an analyzer is powered

If this is inconvenient or cannot be avoided:

5. Cycle power to the instrument after connecting the sensor or..
6. Perform a Slope Calibration or Standard Calibration routine after connecting the sensor

Following these guidelines will extend the life of the incandescent lamp and avoid premature warnings and faults due to reduced lamp life.

9.3 TROUBLESHOOTING CALIBRATION PROBLEMS

Once the user has completed the calibration sequence, the analyzer verifies that the calibration meets certain requirements. If the calibration is valid, the analyzer displays the calibration complete screen and updates the calibration. If the calibration does not meet requirements, the calibration error screen appears. The analyzer retains the original calibration.

Calibration method	Section
User-prepared standard (Section 6.2)	9.3.1
Commercial standard (Section 6.3)	9.3.2
Grab sample (Section 6.4)	9.3.3

9.3.1 Calibration Error-User-Prepared Standard (Section 6.2)

- A. For best results calibrate using freshly prepared 20.0 NTU standard. Use the procedure in Section 6.3.2.
- B. Has the stock 4000 NTU standard exceeded its expiration date?
- C. Is the turbidity of the dilution water less than 0.5 NTU? If you are using bottled distilled or deionized water, open a fresh bottle and repeat the calibration.
- D. Are the lamp and detector windows clean? See Section 7.2.1.
- E. Is the sensor securely seated in calibration cup with no light leaking in? Putting a dark cloth over the sensor and calibration cup and removing it should have no effect on the reading. Are both the lamp and photodiode windows completely submerged in the standard?
- F. Was the correct turbidity value entered in the analyzer?

9.3.2 Calibration Error-Commercial Standard (Section 6.3)

- A. For best results calibrate using 20.0 NTU standard.
- B. Has the calibration standard exceeded its expiration date?
- C. Are the lamp and detector windows clean? See Section 7.2.1.
- D. Is the sensor is securely seated in calibration cup with no light leaking in? Putting a dark cloth over the sensor and calibration cup and removing it should have no effect on the reading. Are both the lamp and photodiode windows completely submerged in the standard?
- E. Was the correct turbidity value entered in the analyzer?

9.3.3 Calibration Error-Grab Sample (Section 6.4)

- A. Was the referee instrument used to measure the grab sample properly calibrated?
- B. Was the process turbidity reading stable when the grab sample was taken? Do not attempt a grab sample calibration when turbidity readings are rapidly changing.
- C. Is the sensor securely seated in the measuring chamber with no light leaking in? Putting a dark cloth over the sensor and measuring chamber and removing it should have no effect on the reading.
- D. Is the sensor clean? See Section 7.2.1.
- E. Was the correct turbidity value entered in the analyzer?

9.4 TROUBLESHOOTING OTHER PROBLEMS

Problem	Section
Readings are erratic	9.4.1
Readings drift	9.4.2
Analyzer responds too slowly to changes in turbidity	9.4.3
Flow is too low	9.4.4
Readings are lower or higher than expected	9.4.5
Current output is too low	9.4.6
Alarm relays do not operate when setpoint is exceeded	9.4.7
Display is unreadable-too faint or all pixels dark	9.4.8

9.4.1 Readings are erratic

Erratic readings are usually caused by air bubbles drifting through the measurement zone of the sensor. Air bubbles reflect light onto the detector and cause spikes in the turbidity reading. A debubbling chamber helps remove large bubbles. An orifice in the outlet of the debubbler helps eliminate outgassing by putting back pressure on the debubbler. Outgassing can occur when the pressure of the sample is reduced or when a cold sample warms up. A bubble rejection filter in the analyzer software also helps reduce the effect of bubbles.

- A. Be sure the bubble rejection filter is on and increase the signal averaging time. See Section 5.5.
- B. If the inlet pressure is high enough, increase the back pressure on the debubbler using a valve or a valved rotameter (PN 24103-00) installed in the outlet of the debubbler. Do not exceed 30 psig (308 kPa abs). Increasing the back pressure reduces the sample flow and increases the system response time. If the inlet pressure is too low, increasing the back pressure might not be feasible.
- C. If bubbles persist, increase the back pressure and use a sample pump to increase the inlet pressure.

9.4.2 Readings drift

Gradual downward drift in readings is caused by dirt accumulating on the lamp or detector windows. The dirt reduces the amount of light entering the measuring zone in the sample and blocks scattered light from reaching the detector. Upward drift is usually caused by bubbles adhering to the lamp or detector windows. The bubbles, which act like lenses, direct light onto the detector and increase the apparent turbidity reading. Once the bubbles get large enough, they break away from the surface of the detector and the turbidity reading drops.

- A. If downward drift is occurring, inspect the sensor windows for cleanliness. See Section 7.2.1 for cleaning instructions.
- B. If upward drift is occurring, remove the sensor completely from the debubbler and then replace it. If readings drop back to normal or expected values, then the upward drift was probably caused by bubbles accumulating on the sensor. (Removing the sensor from the debubbler causes the air bubbles to break.) To reduce bubble accumulation, increase the back pressure on the debubbler using a valve or valved rotameter (PN 24103-00) installed in the outlet of the debubbler. Do not exceed 30 psig (308 kPa abs). Increasing the back pressure reduces the sample flow and increases the system response time. If the inlet pressure is too low, increasing the back pressure might not be feasible.
- C. If bubbles persist, increase the back pressure and use a sample pump to increase the inlet pressure.

9.4.3 Analyzer responds too slowly to changes in turbidity

Response time is primarily a function of sample flow rate, distance between the sample point and analyzer, and the diameter of the sample tubing. Because the debubbler has a flow restrictor on the outlet to increase back pressure, sample flow rate is primarily determined by the inlet pressure.

- A. If possible, increase the inlet pressure.
- B. If increasing the inlet pressure is not feasible, move the sensor closer to the sample point.

9.4.4 Flow is too low

The debubbler is fitted with a 0.040 inch (1 mm) diameter orifice in the outlet. The orifice puts back pressure on the debubbler, which helps reduce outgassing. If the inlet pressure is about 3.5 psig (125 kPa abs), the flow through the debubbler will be about 250 mL/min. The response time to a step change at 250 mL/min is about **sss** minutes. If the flow is too low, the response time may become excessive. The only way to improve the response time is to reduce the back pressure or to increase the inlet pressure.

- A. To eliminate back pressure, remove the orifice from the debubbler. See Section 7.3.
- B. If removing the orifice causes outgassing — the symptom of outgassing is an upward drift in apparent turbidity — increase the back pressure by a small amount. Use a valve or a valved rotameter (PN 24103-00) in the debubbler outlet. Do not exceed 30 psig (308 kPa abs).
- C. If outgassing continues to persist, increase the back pressure. To maintain flow, use a pump to increase the inlet pressure.

9.4.5 Readings are lower or higher than expected

- A. Is the instrument to which readings are being compared properly calibrated?
- B. Are samples being tested immediately after sampling? If samples are allowed to sit too long before testing, the turbidity may change.
- C. Are the measurement chamber and debubbler clean?. Sample flow may be stirring up solids that have previously settled out in the debubbler and measurement chamber, increasing the apparent turbidity. See Section 7.3.1 for cleaning procedure.

9.4.6 Analog current is too low

Load resistance is too high. Maximum load is 600 Ω .

9.4.7 Alarm relays do not operate when setpoint is exceeded

- A. Is the alarm board in place and properly seated?
- B. Is the alarm logic (high/low) and dead band correct?
- C. Has the setpoint has been properly entered?

9.4.8 Display is unreadable — too faint or all pixels dark.

While holding down the MENU key, press **s** or **t** until the display has the correct contrast.

This page left blank intentionally

SECTION 10.0 RETURN OF MATERIAL

10.1 GENERAL.

To expedite the repair and return of instruments, proper communication between the customer and the factory is important. Before returning a product for repair, call 1-949-757-8500 for a Return Materials Authorization (RMA) number.

10.2 WARRANTY REPAIR.

The following is the procedure for returning instruments still under warranty:

1. Call Rosemount Analytical for authorization.
2. To verify warranty, supply the factory sales order number or the original purchase order number. In the case of individual parts or sub-assemblies, the serial number on the unit must be supplied.
3. Carefully package the materials and enclose your "Letter of Transmittal" (see Warranty). If possible, pack the materials in the same manner as they were received.
4. Send the package prepaid to:

Emerson Process Management
Liquid Division
2400 Barranca Parkway
Irvine, CA 92606

Attn: Factory Repair

RMA No. _____

Mark the package: Returned for Repair

Model No. _____

10.3 NON-WARRANTY REPAIR.

The following is the procedure for returning for repair instruments that are no longer under warranty:

1. Call Rosemount Analytical for authorization.
2. Supply the purchase order number, and make sure to provide the name and telephone number of the individual to be contacted should additional information be needed.
3. Do Steps 3 and 4 of Section 9.2.

NOTE

Consult the factory for additional information regarding service or repair.

APPENDIX

This procedure describes how to verify linearity between turbidity and TSS.

1. Collect a sample of the process liquid—you may need 10 L or more if you use the Clarity II for measuring turbidity. If you use a laboratory turbidimeter, you will need less volume. The Clarity II requires about 500 mL for the measurement; laboratory turbidimeters require 50 mL or less. Verify that the turbidity of the sample is less than 200 NTU. Store the in a clean bottle.
2. Filter a portion of the sample to obtain at least 5 L of dilution liquid. The filtrate is needed to dilute the sample in subsequent steps. Verify that the turbidity of the dilution water is low. If filtering the sample is impractical, use deionized water for dilution.
3. Measure the total suspended solids (TSS) in the sample obtained in step 1. Thoroughly mix the sample before withdrawing liquid. A magnetic stirrer is best, but inverting the sample repeatedly for about a minute works, too. Avoid violent shaking or mixing. Refer to any standard reference work on water and wastewater testing for the procedure for determining TSS.
4. Dilute the sample from step 1, by a factor of 0.9, 0.7, 0.5, 0.3, and 0.1. See the table for recommended volumes. Measure TSS and turbidity for each dilution. For lower TSS values, use a larger volume of sample.

Dilution factor	Volume of stock, mL	Final volume, mL	Volume for Clarity II, mL	Volume for TSS, mL
1.00	--	--	500	50 - 250
0.9	900	1000	500	50 - 250
0.7	700	1000	500	50 - 250
0.5	500	1000	500	50 - 250
0.3	300	1000	500	50 - 250
0.1	100	1000	500	50 - 250

5. Plot the data obtained in step 4, with turbidity on the y-axis and TSS on the x-axis. Fit the best straight line to the data.
6. Locate two points (P1 and P2) on the line separated as much as possible. Read the ppm and NTU value for each point and enter these into the analyzer. See Section 6.5.2.

WARRANTY

Seller warrants that the firmware will execute the programming instructions provided by Seller, and that the Goods manufactured or Services provided by Seller will be free from defects in materials or workmanship under normal use and care until the expiration of the applicable warranty period. Goods are warranted for twelve (12) months from the date of initial installation or eighteen (18) months from the date of shipment by Seller, whichever period expires first. **Consumables, such as glass electrodes, membranes, liquid junctions, electrolyte, o-rings, catalytic beads, etc., and Services are warranted for a period of 90 days from the date of shipment or provision.**

Products purchased by Seller from a third party for resale to Buyer ("Resale Products") shall carry only the warranty extended by the original manufacturer. Buyer agrees that Seller has no liability for Resale Products beyond making a reasonable commercial effort to arrange for procurement and shipping of the Resale Products.

If Buyer discovers any warranty defects and notifies Seller thereof in writing during the applicable warranty period, Seller shall, at its option, promptly correct any errors that are found by Seller in the firmware or Services, or repair or replace F.O.B. point of manufacture that portion of the Goods or firmware found by Seller to be defective, or refund the purchase price of the defective portion of the Goods/Services.

All replacements or repairs necessitated by inadequate maintenance, normal wear and usage, unsuitable power sources, unsuitable environmental conditions, accident, misuse, improper installation, modification, repair, storage or handling, or any other cause not the fault of Seller are not covered by this limited warranty, and shall be at Buyer's expense. Seller shall not be obligated to pay any costs or charges incurred by Buyer or any other party except as may be agreed upon in writing in advance by an authorized Seller representative. All costs of dismantling, reinstallation and freight and the time and expenses of Seller's personnel for site travel and diagnosis under this warranty clause shall be borne by Buyer unless accepted in writing by Seller.

Goods repaired and parts replaced during the warranty period shall be in warranty for the remainder of the original warranty period or ninety (90) days, whichever is longer. This limited warranty is the only warranty made by Seller and can be amended only in a writing signed by an authorized representative of Seller. Except as otherwise expressly provided in the Agreement, THERE ARE NO REPRESENTATIONS OR WARRANTIES OF ANY KIND, EXPRESS OR IMPLIED, AS TO MERCHANTABILITY, FITNESS FOR PARTICULAR PURPOSE, OR ANY OTHER MATTER WITH RESPECT TO ANY OF THE GOODS OR SERVICES.

RETURN OF MATERIAL

Material returned for repair, whether in or out of warranty, should be shipped prepaid to:

**Emerson Process Management
Liquid Division
2400 Barranca Parkway
Irvine, CA 92606**

The shipping container should be marked:

Return for Repair

Model _____

The returned material should be accompanied by a letter of transmittal which should include the following information (make a copy of the "Return of Materials Request" found on the last page of the Manual and provide the following thereon):

1. Location type of service, and length of time of service of the device.
2. Description of the faulty operation of the device and the circumstances of the failure.
3. Name and telephone number of the person to contact if there are questions about the returned material.
4. Statement as to whether warranty or non-warranty service is requested.
5. Complete shipping instructions for return of the material.

Adherence to these procedures will expedite handling of the returned material and will prevent unnecessary additional charges for inspection and testing to determine the problem with the device.

If the material is returned for out-of-warranty repairs, a purchase order for repairs should be enclosed.



*The right people,
the right answers,
right now.*

ROSEMOUNT ANALYTICAL
CUSTOMER SUPPORT CENTER
1-800-854-8257



Credit Cards for U.S. Purchases Only.



ON-LINE ORDERING NOW AVAILABLE ON OUR WEB SITE
<http://www.rosemountanalytical.com>

Specifications subject to change without notice.

Emerson Process Management

2400 Barranca Parkway
Irvine, CA 92606 USA
Tel: (949) 757-8500
Fax: (949) 474-7250

<http://www.rosemountanalytical.com>

© Rosemount Analytical Inc. 2014

