

# Oxymitter 4000 Oxygen Transmitter





# HIGHLIGHTS OF CHANGES

Effective May 31, 2006 Rev. 4.0

Page	Summary
General	Reformatted entire manual from a two column layout. Removed all references to JIS specifications. Replaced SPS 4000 information with SPS 4001B information.
Cover	Updated photo, revision number and date.
viii	Removed Figure 3. Oxymitter 4000 with SPS 4000 Wiring Diagram from Quick Start Guide.
1-2	Revised Figure 1-1 to show SPS 4001B and updated IMPS 4000.
1-5	Revised Figure 1-2 to show SPS 4001B.
1-8	Added step 11 and Figure 1-6.
1-10, 1-11	Revised Figure 1-8 and Figure 1-9 to show SPS 4001B.
1-12	Removed Components paragraph.
1-13	Removed Figure 1-9. SPS 4000.
1-15	Updated Figure 1-14. Abrasive Shield Assembly.
1-16, 1-17	Revised Specifications.
1-18, 1-19	Revised Product Matrix table.
2-1	Added two additional warnings.
2-5	Removed Figure 2-3. Oxymitter 4000 Installation (with SPS 4000).
2-12, 2-15	Revised Figure 2-9 and Figure 2-10 to show grounding locations.
2-16	Revised Install Interconnecting Cable paragraph. Removed Electrical Installation (For Oxymitter 4000 with SPS 400).
2-18	Added SPS 4001B Connections.
3-1, 4-1	Revised Terminal Block Wiring text.
5-2	Added Reference Air information.
7-9	Added D/A Trim Procedure.
8-3	Revised Alarm Indications to include signal alarm levels.
8-23	Removed SPS 4000 Troubleshooting.
9-8, 9-9	Revised Figure 9-3 and Figure 9-4.
9-11, 9-13	Revised Figure 9-6 and Figure 9-7 with updated circuit board.
9-17	Revised Figure 9-10.
9-20	Removed SPS 4000 Maintenance and Component Replacement.
10-3, 10-4	Updated part numbers for the Cell Replacement Kit, ANSI 15' and 18'.
10-4	Updated part numbers for the Contact and Thermocouple Replacement Assembly, 15' and 18'.

# HIGHLIGHTS OF CHANGES (CONTINUED)

## Effective May 31, 2006 Rev. 4.0 (Continued)

<b>Page</b>	<b>Summary</b>
10-5	Removed Ceramic Diffuser Hub Assy. Changed part numbers 4851B89G04 and 4851B90G04 to 10 microns.
10-6	Revised Table 10-2. Removed Replacement Parts for SPS 4000 table.
11-4	Revised Figure 11-4 to show the SPS 4001B.
11-6	Added Figure 11-7 and explanation of the Oxybalance Display and Averaging System.
A-21	Added General Precautions for Handling and Storing High Pressure Gas Cylinders.

## Effective January 2007 Rev. 4.1

<b>Page</b>	<b>Summary</b>
General	Revised reference air specifications to read 1 l/min (2 scfh) throughout the manual.
Page 8-22	Added the paragraph and procedural steps after 'Heater Not Open, but Unable to Reach 736°C Setpoint.'
Page A-2 thru A-24	Added note 11 to the safety data section. Added new language translations.
Page B-1	Updated the return of materials address.
Back cover	Updated the address blocks.

## Effective July 2008 Rev. 4.2

<b>Page</b>	<b>Summary</b>
Page 6-4	Added note regarding cleaning the LOI screen before use.

# Table of Contents

	Essential Instructions . . . . .	i
<b>SECTION i</b>		
<b>Introduction</b>	Preface . . . . .	iv
	Definitions . . . . .	iv
	Symbols . . . . .	iv
	What You Need To Know . . . . .	v
	Can You Use the Quick Start Guide? . . . . .	vii
	Quick Start Guide for Oxymitter 4000 Systems . . . . .	viii
	Quick Reference Guide Manual Calibration Instructions . . . . .	ix
	HART Communicator Fast Key Sequences . . . . .	x
<b>SECTION 1</b>		
<b>Description and Specifications</b>	Component Checklist . . . . .	1-1
	System Overview . . . . .	1-1
	Scope . . . . .	1-1
	System Description . . . . .	1-3
	System Configuration . . . . .	1-4
	System Features . . . . .	1-4
	Handling the Oxymitter 4000 . . . . .	1-8
	System Considerations . . . . .	1-9
	IMPS 4000 (Optional) . . . . .	1-12
	SPS 4001B (Optional) . . . . .	1-12
	Mounting . . . . .	1-12
	Operation . . . . .	1-12
	Model 751 Remote Powered Loop LCD Display . . . . .	1-13
	Probe Options . . . . .	1-13
	Diffusion Elements . . . . .	1-13
	Specifications . . . . .	1-16
<b>SECTION 2</b>		
<b>Configuration of Oxymitter 4000 with Membrane Keypad</b>	Verify Installation . . . . .	2-1
	Mechanical Installation . . . . .	2-1
	Terminal Block Wiring . . . . .	2-1
	Oxymitter 4000 Configuration . . . . .	2-2
	Logic I/O . . . . .	2-5
	Recommended Configuration . . . . .	2-6
<b>SECTION 3</b>		
<b>Installation</b>	Mechanical Installation . . . . .	3-2
	Selecting Location . . . . .	3-2
	Probe Installation . . . . .	3-2
	Remote Electronics Installation . . . . .	3-9
	Electrical Installation (with Integral Electronics) . . . . .	3-10
	Electrical Installation (with Remote Electronics) . . . . .	3-13
	Install Interconnecting Cable . . . . .	3-16
	Pneumatic Installation . . . . .	3-16
	IMPS 4000 Connections . . . . .	3-18
	SPS 4001B Connections . . . . .	3-18

# Oxymitter 4000

<b>SECTION 4</b>		
<b>Configuration of Oxymitter 4000 with LOI</b>	Verify installation . . . . .	4-1
	Mechanical Installation . . . . .	4-1
	Terminal Block Wiring . . . . .	4-1
	Oxymitter 4000 Configuration . . . . .	4-2
	Logic I/O . . . . .	4-4
	Recommended Configuration . . . . .	4-6
<b>SECTION 5</b>		
<b>Startup and Operation of Oxymitter 4000 with Membrane Keypad</b>	Power Up . . . . .	5-1
	Operation . . . . .	5-2
	Overview . . . . .	5-2
<b>SECTION 6</b>		
<b>Startup and Operation of Oxymitter 4000 with LOI</b>	Power Up . . . . .	6-1
	Start Up Oxymitter 4000 Calibration . . . . .	6-3
	Navigating the Local Operator Interface . . . . .	6-3
	Overview . . . . .	6-3
	Lockout . . . . .	6-3
	LOI Key Designations . . . . .	6-4
	LOI Menu Tree . . . . .	6-4
	Oxymitter 4000 Setup at the LOI . . . . .	6-6
	LOI Installation . . . . .	6-9
	Oxymitter 4000 Test Points . . . . .	6-10
	Remote Powered Loop LCD Display (Optional) . . . . .	6-10
<b>SECTION 7</b>		
<b>HART/AMS</b>	Overview . . . . .	7-1
	HART Communicator Signal Line Connections . . . . .	7-2
	HART Communicator PC Connections . . . . .	7-2
	Off-Line and On-Line Operations . . . . .	7-4
	Logic I/O Configurations . . . . .	7-4
	HART/AMS Menu Tree . . . . .	7-4
	HART Communicator O <sub>2</sub> Cal Method . . . . .	7-8
	Defining a Timed Calibration via HART . . . . .	7-9
	D/A Trim Procedure . . . . .	7-9
<b>SECTION 8</b>		
<b>Troubleshooting</b>	Overview . . . . .	8-1
	General . . . . .	8-3
	Alarm Indications . . . . .	8-3
	Alarm Contacts . . . . .	8-4
	Identifying and Correcting Alarm Indications . . . . .	8-5
	Heater Not Open, but Unable to Reach 736°C Setpoint . . . . .	8-22
	Calibration Passes, but Still Reads Incorrectly . . . . .	8-22
<b>SECTION 9</b>		
<b>Maintenance and Service</b>	Overview . . . . .	9-1
	Calibration with Keypad . . . . .	9-1
	Automatic Calibration . . . . .	9-2
	Semi-Automatic Calibration . . . . .	9-3
	Manual Calibration with Membrane Keypad . . . . .	9-3
	Calibration with LOI . . . . .	9-5
	Oxymitter 4000 Repair . . . . .	9-7
	Removal and Replacement of Probe . . . . .	9-7

<b>SECTION 10</b>	Probe Replacement Parts . . . . .	10-1
<b>Replacement Parts</b>	Electronics Replacement Parts . . . . .	10-6
<b>SECTION 11</b>	HART Handheld 375 Communicator . . . . .	11-1
<b>Optional</b>	Asset Management Solutions (AMS) . . . . .	11-2
<b>Accessories</b>	By-Pass Packages . . . . .	11-2
	IMPS 4000 Intelligent Multiprobe Test Gas Sequencer . . . . .	11-3
	SPS 4001B Single Probe Autocalibration Sequencer . . . . .	11-4
	O <sub>2</sub> Calibration Gas . . . . .	11-5
	Catalyst Regeneration . . . . .	11-6
	OxyBalance Display and Averaging System . . . . .	11-6
<b>APPENDIX A</b>	Safety Instructions . . . . .	A-2
<b>Safety Data</b>	Safety Data Sheet for Ceramic Fiber Products . . . . .	A-24
	. . . . .	A-30
<b>APPENDIX B</b>	Returning Material . . . . .	B-1
<b>Return of Material</b>		

# Oxymitter 4000

**Instruction Manual**

IM-106-340, Rev 4.2

July 2008

---



# Oxymitter Oxygen Transmitters

READ THIS PAGE BEFORE PROCEEDING!

## ESSENTIAL INSTRUCTIONS

Emerson Process Management designs, manufactures and tests its products to meet many national and international standards. Because these instruments are sophisticated technical products, **you MUST properly install, use, and maintain them** to ensure they continue to operate within their normal specifications. The following instructions **MUST be adhered to** and integrated into your safety program when installing, using, and maintaining Emerson's Rosemount Analytical products. Failure to follow the proper instructions may cause any one of the following situations to occur: Loss of life; personal injury; property damage; damage to this instrument; and warranty invalidation.

- **Read all instructions** prior to installing, operating, and servicing the product.
- If you do not understand any of the instructions, **contact your Emerson Process Management representative** for clarification.
- **Follow all warnings, cautions, and instructions** marked on and supplied with the product.
- **Inform and educate your personnel in the proper installation, operation, and maintenance of the product.**
- **Install your equipment as specified in the Installation Instructions of the appropriate Instruction Manual and per applicable local and national codes.** Connect all products to the proper electrical and pressure sources.
- To ensure proper performance, **use qualified personnel** to install, operate, update, program, and maintain the product.
- When replacement parts are required, ensure that qualified people use replacement parts specified by Emerson Process Management. Unauthorized parts and procedures can affect the product's performance, place the safe operation of your process at risk, **and VOID YOUR WARRANTY.** Look-alike substitutions may result in fire, electrical hazards, or improper operation.
- **Ensure that all equipment doors are closed and protective covers are in place, except when maintenance is being performed by qualified persons, to prevent electrical shock and personal injury.**

The information contained in this document is subject to change without notice.

### CAUTION

If a Model 275/375 Universal HART® Communicator is used with this unit, the software within the Model 275/375 may require modification. If a software modification is required, please contact your local Emerson Process Management Service Group or National Response Center at 1-800-433-6076 or 1-888-433-6829.

# Oxymitter 4000

---

**Instruction Manual**

IM-106-340, Rev. 4.2

July 2008

---

# Section i Introduction

---

Preface .....	page iv
Definitions .....	page iv
Symbols .....	page iv
What You Need To Know .....	page v
Can You Use the Quick Start Guide? .....	page vii
Quick Start Guide for Oxymitter 4000 Systems .....	page viii
Quick Reference Guide Manual Calibration Instructions	page ix
HART Communicator Fast Key Sequences .....	page x

---

# Oxymitter 4000

---

## PREFACE

The purpose of this manual is to provide information concerning the components, functions, installation and maintenance of the Oxymitter 4000 Oxygen Transmitter.

Some sections may describe equipment not used in your configuration. The user should become thoroughly familiar with the operation of this module before operating it. Read this instruction manual completely.

## DEFINITIONS

The following definitions apply to WARNINGS, CAUTIONS, and NOTES found throughout this publication.

** WARNING**

Highlights an operation or maintenance procedure, practice, condition, statement, etc. If not strictly observed, could result in injury, death, or long-term health hazards of personnel.

** WARNING**

Highlights an operation or maintenance procedure, practice, condition, statement, etc. If not strictly observed, could result in damage to or destruction of equipment, or loss of effectiveness.





---

## NOTE

Highlights an essential operating procedure, condition, or statement.

---

## SYMBOLS

-  : EARTH (GROUND) TERMINAL
-  : PROTECTIVE CONDUCT OR TERMINAL
-  : RISK OF ELECTRICAL SHOCK
-  : WARNING: REFER TO INSTRUCTION MANUAL

---

## NOTE TO USERS

The number in the lower right corner of each illustration in this publication is a manual illustration number. It is not a part number, and is not related to the illustration in any technical manner.

---

**WHAT YOU NEED TO KNOW**

**⚠ WARNING**

Highlights an operation or maintenance procedure, practice, condition, statement, etc. If not strictly observed, could result in injury, death, or long-term health hazards of personnel.

**BEFORE INSTALLING AND WIRING A ROSEMOUNT ANALYTICAL OXYMITTER 4000 OXYGEN TRANSMITTER**

1. What type of installation does your system require?

Use the following drawings, Figure 1 and Figure 2, to identify which type of installation is required for your Oxymitter 4000 system.

Figure 1. Installation Options - Oxymitter 4000 with Integral Electronics

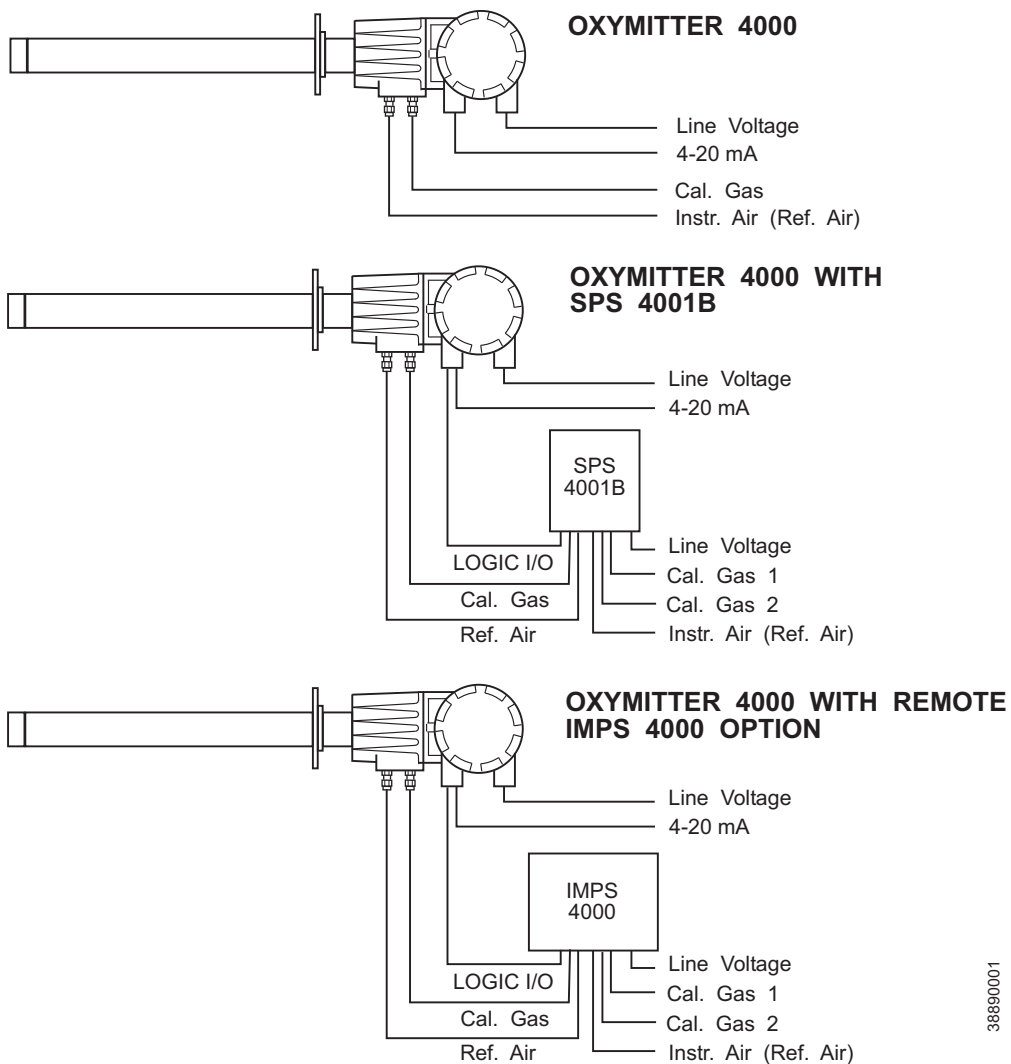

38890001

# Oxymitter 4000

Figure 2. Installation Options - Oxymitter 4000 with Remote Electronics

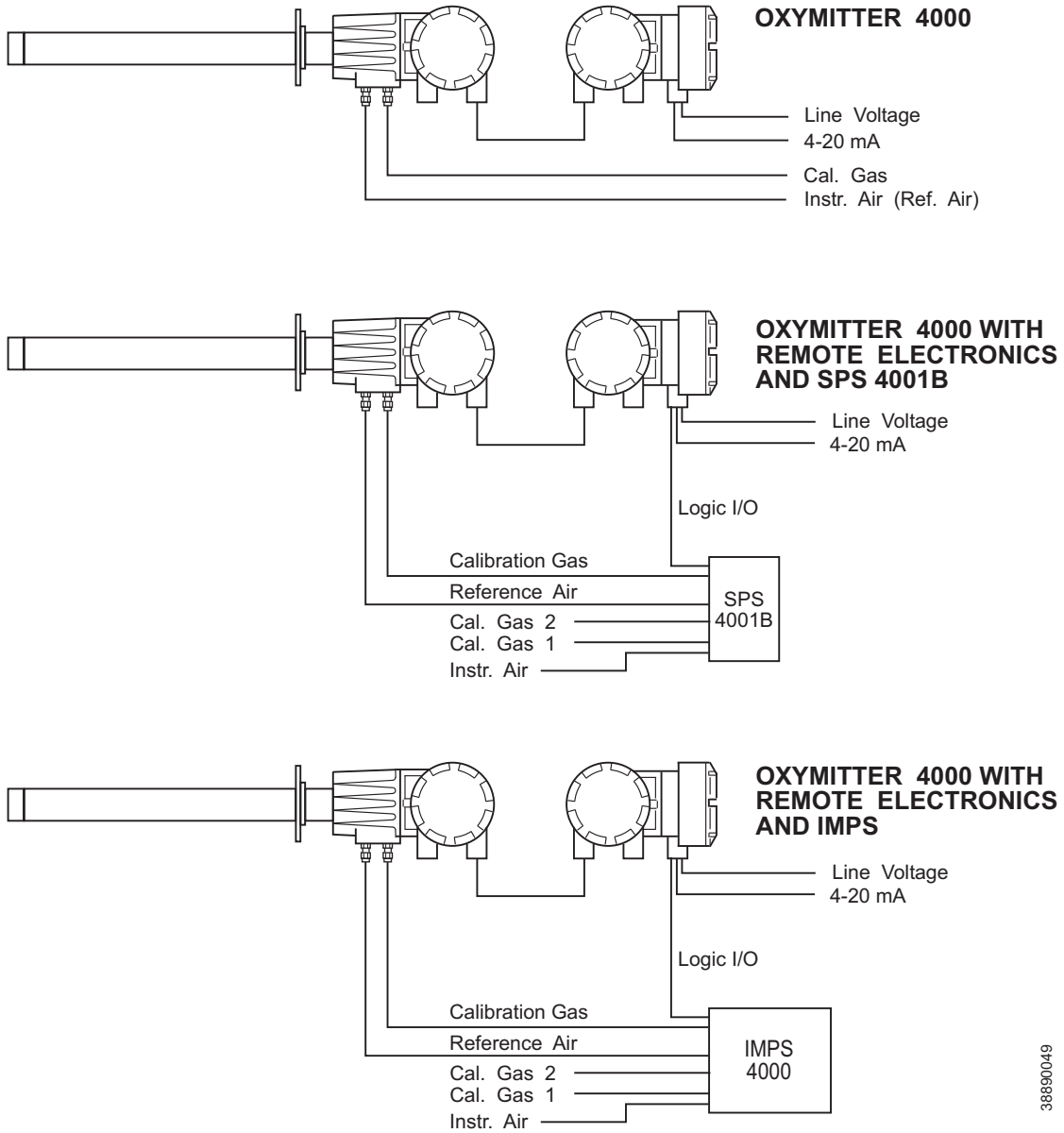

38890049

**CAN YOU USE THE  
QUICK START GUIDE?**

**Use this Quick Start Guide if...**

1. Your system requires an Oxymitter 4000 with or without the SPS 4001B OPTION. Installation options for the Oxymitter 4000 are shown in Figure 1.
2. Your system does NOT require an IMPS 4000 OPTION installation.
3. Your system does NOT use a Remote Electronics as shown in Figure 2.
4. You are familiar with the installation requirements for the Oxymitter 4000 Oxygen Transmitter. You are familiar with the installation requirements for the Oxymitter 4000 Oxygen Transmitter with a SPS 4001B.

**If you cannot use the Quick Start Guide, turn to Section 3: Installation, in this Instruction Manual.**

## **QUICK START GUIDE FOR OXYMITTER 4000 SYSTEMS**

**Before using the Quick Start Guide, please read "WHAT YOU NEED TO KNOW BEFORE INSTALLING AND WIRING A ROSEMOUNT ANALYTICAL OXYMITTER 4000 OXYGEN TRANSMITTER" on the preceding page.**

1. Install the Oxymitter 4000 in an appropriate location on the stack or duct. Refer to "Selecting Location" in Section 3: Installation, for information on selecting a location for the Oxymitter 4000.
2. If using an SPS 4001B, connect the calibration gasses to the appropriate fittings on the SPS 4001B manifold.
3. Connect reference air to the Oxymitter 4000 or SPS 4001B, as applicable.
4. If using an SPS 4001B, make the wiring connections as shown in the SPS 4001B Single Probe Autocalibration Sequencer Instruction Manual.
5. If NOT using an SPS 4001B, make the following wire connections as shown in Figure 3: line voltage, 4-20 mA, and logic I/O.
6. Verify the Oxymitter 4000 switch configuration is as desired. Refer to "Oxymitter 4000 Configuration", "SW1 Setting", and "SW2 Setting" all in Section 2: Configuration of Oxymitter 4000 with Membrane Keypad, or "Oxymitter 4000 Configuration", "SW1 Setting", and "SW2 Setting" all in Section 4: Configuration of Oxymitter 4000 with LOI.
7. Apply power to the Oxymitter 4000; the cell heater will turn on. Allow approximately one half hour for the cell to heat to operating temperature. Once the ramp cycle has completed and the Oxymitter 4000 is at normal operation, proceed with step 8 or 9.
8. If using an SPS 4001B, initiate a semi-automatic calibration.
9. If NOT using an SPS 4001B, perform a manual calibration. Refer to "Calibration with Keypad" or "Calibration with LOI" both in Section 9: Maintenance and Service, in this instruction manual.

---

### **NOTE**

If your system has a membrane keypad you can refer to the Quick Start Guide on the following pages.

---



Figure 3. Oxymitter 4000 without SPS 4001B Wiring Diagram

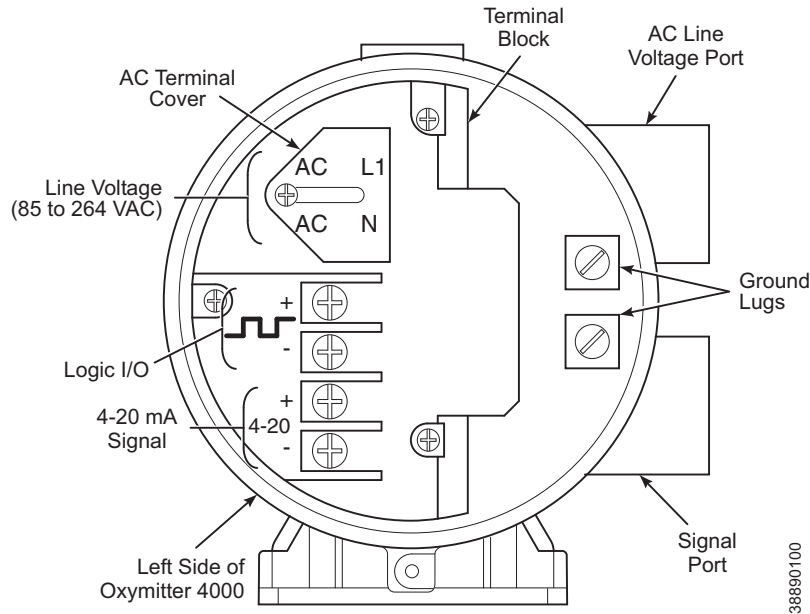

**QUICK REFERENCE  
GUIDE MANUAL  
CALIBRATION  
INSTRUCTIONS**

**Performing a Manual Calibration with a Membrane Keypad**

1. Place the control loop in manual.
2. Press the CAL key. The CAL LED will light solid.
3. Apply the first calibration gas.
4. Press the CAL key. When the unit has taken the readings using the first calibration gas, the CAL LED will flash continuously.
5. Remove the first calibration gas and apply the second calibration gas.
6. Push the CAL key. The CAL LED will light solid. When the unit has taken the readings using the second calibration gas, the CAL LED will flash a two-pattern flash or a three-pattern flash. A two-pattern flash equals a valid calibration, three-pattern flash equals an invalid calibration.
7. Remove the second calibration gas and cap off the calibration gas port.
8. Press the CAL key. The CAL LED will be lit solid as the unit purges. When the purge is complete, the CAL LED will turn off.
9. If the calibration was valid, the DIAGNOSTIC ALARMS LEDs indicate normal operation. If the new calibration values are not within the parameters, the DIAGNOSTIC ALARMS LEDs will indicate an alarm.
10. Place the control loop in automatic.

### HART COMMUNICATOR FAST KEY SEQUENCES

Perform Calibration

2	3	1	1
---	---	---	---

O<sub>2</sub> Upper Range Value

3	2	1
---	---	---

Trim Analog Output

2	4
---	---

Analog Output Lower Range Value

3	2	2
---	---	---

Toggle Analog Output Tracking

2	3	1	2
---	---	---	---

View O<sub>2</sub> Value

1	1	1
---	---	---

View Analog Output

1	2	1
---	---	---

36890000

#### Technical Support Hotline:

For assistance with technical problems, please call the Customer Support Center (CSC). The CSC is staffed 24 hours a day, 7 days a week.

Phone: 1-800-433-6076

1-440-914-1261

In addition to the CSC, you may also contact Field Watch. Field Watch coordinates Emerson Process Management's field service throughout the U.S. and abroad.

Phone: 1-800-654-RSMT (1-800-654-7768)

Emerson Process Management may also be reached via the Internet through e-mail and the World Wide Web:

e-mail: [GAS.CSC@emersonprocess.com](mailto:GAS.CSC@emersonprocess.com)

World Wide Web: [www.raihome.com](http://www.raihome.com)

---

# Section 1 Description and Specifications

---

---

Component Checklist .....	page 1-1
System Overview .....	page 1-1
IMPS 4000 (Optional) .....	page 1-12
SPS 4001B (Optional) .....	page 1-12
Model 751 Remote Powered Loop LCD Display .....	page 1-13
Probe Options .....	page 1-13
Specifications .....	page 1-16

---

## COMPONENT CHECKLIST

A typical Rosemount Analytical Oxymitter 4000 Oxygen Transmitter should contain the items shown in Figure 1-1. Record the part number, serial number, and order number for each component of your system in the table located on the first page of this manual.

Also, use the product matrix in Table 1-1 at the end of this section to compare your order number against your unit. The first part of the matrix defines the model. The last part defines the various options and features of the Oxymitter 4000. Ensure the features and options specified by your order number are on or included with the unit.

## SYSTEM OVERVIEW

### Scope

This Instruction Manual is designed to supply details needed to install, start up, operate, and maintain the Oxymitter 4000. Signal conditioning electronics outputs a 4-20 mA signal representing an O<sub>2</sub> value and provides a membrane keypad or fully functional Local Operator Interface (optional) for setup, calibration, and diagnostics. This same information, plus additional details, can be accessed with the HART Model 275/375 handheld communicator or Asset Management Solutions (AMS) software.

# Oxymitter 4000

Figure 1-1. Typical System Package

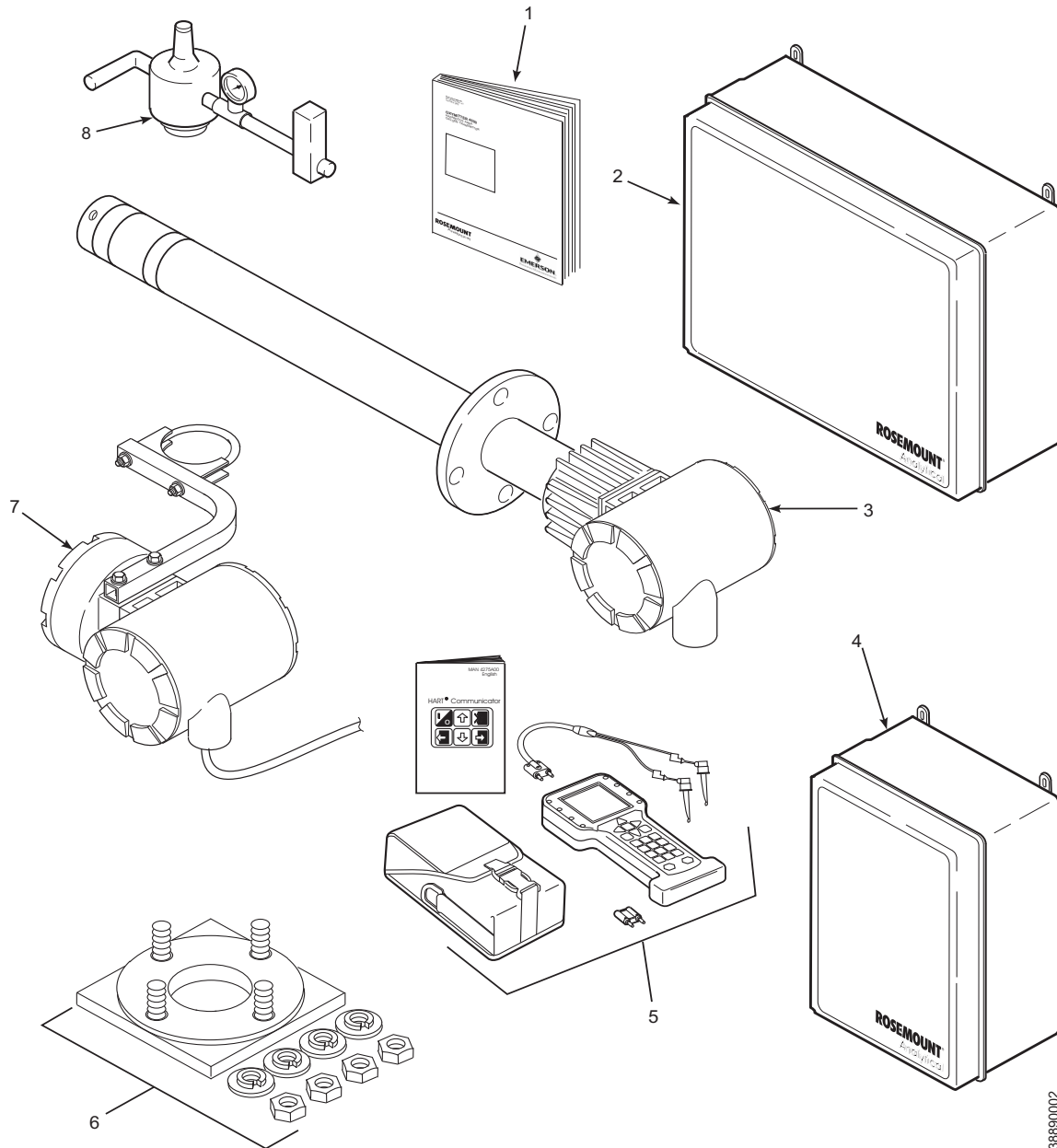

38890002

1. Instruction Manual
2. IMPS 4000 Intelligent Multiprobe Test Gas Sequencer (Optional)
3. Oxymitter 4000 with Integral Electronics
4. SPS 4001B Single Probe Autocalibration Sequencer (Optional) (Shown with reference air option)
5. HART@ 275/375 Communicator Package (Optional)
6. Adapter Plate with Mounting Hardware and Gasket
7. Remote Electronics and Cable (Optional)
8. Reference Air Set (used if SPS 4001B without reference air option or IMPS 4000 supplied)

**System Description**

The Oxymitter 4000 is designed to measure the net concentration of oxygen in an industrial combustion processes process; i.e., the oxygen remaining after all fuels have been oxidized. The probe is permanently positioned within an exhaust duct or stack and performs its task without the use of a sampling system.

The equipment measures oxygen percentage by reading the voltage developed across a heated electrochemical cell, which consists of a small yttria stabilized, zirconia disc. Both sides of the disc are coated with porous metal electrodes. When operated at the proper temperature, the millivolt output voltage of the cell is given by the following Nernst equation:

$$EMF = KT \log_{10}(P1/P2) + C$$

Where:

1. P2 is the partial pressure of the oxygen in the measured gas on one side of the cell.
2. P1 is the partial pressure of the oxygen in the reference air on the opposite side of the cell.
3. T is the absolute temperature.
4. C is the cell constant.
5. K is an arithmetic constant.

---

**NOTE**

For best results, use clean, dry, instrument air (20.95% oxygen) as the reference air.

---

When the cell is at operating temperature and there are unequal oxygen concentrations across the cell, oxygen ions will travel from the high oxygen partial pressure side to the low oxygen partial pressure side of the cell. The resulting logarithmic output voltage is approximately 50 mV per decade. The output is proportional to the inverse logarithm of the oxygen concentration. Therefore, the output signal increases as the oxygen concentration of the sample gas decreases. This characteristic enables the Oxymitter 4000 to provide exceptional sensitivity at low oxygen concentrations.

The Oxymitter 4000 measures net oxygen concentration in the presence of all the products of combustion, including water vapor. Therefore, it may be considered an analysis on a "wet" basis. In comparison with older methods, such as the portable apparatus, which provides an analysis on a "dry" gas basis, the "wet" analysis will, in general, indicate a lower percentage of oxygen. The difference will be proportional to the water content of the sampled gas stream.

# Oxymitter 4000

---

## System Configuration

Oxymitter 4000 units are available in seven length options, giving the user the flexibility to use an in situ penetration appropriate to the size of the stack or duct. The options on length are 18 in. (457 mm), 3 ft (0,91 m), 6 ft (1,83 m), 9 ft (2,7 m), 12 ft (3,66 m), 15 ft (4,57 m), and 18 ft (5,49 m).

The electronics control probe temperature and provide an isolated output, 4-20 mA, that is proportional to the measured oxygen concentration. The power supply can accept voltages of 90-250 VAC and 48/62 Hz; therefore, no setup procedures for power are required. The oxygen sensing cell is maintained at a constant temperature by modulating the duty cycle of the probe heater portion of the electronics. The electronics accepts millivolt signals generated by the sensing cell and produces the outputs to be used by remotely connected user devices. The output is an isolated 4-20 mA linearized current.

The Oxymitter 4000 transmitter is available with an integral or remote electronics package. Two calibration gas sequencers are available: the IMPS 4000 and the SPS 4001B (Figure 1-2).

Systems with multiprobe applications may employ an optional IMPS 4000 Intelligent Multiprobe Test Gas Sequencer. The IMPS 4000 provides automatic calibration gas sequencing for up to four Oxymitter 4000 units and accommodates autocalibrations based on the CALIBRATION RECOMMENDED signal from the Oxymitter 4000, a timed interval set up in HART or the IMPS 4000, or whenever a calibration request is initiated.

For systems with one or two Oxymitter 4000 units per combustion process, an optional SPS 4001B Single Probe Autocalibration Sequencer can be used with each Oxymitter 4000 to provide automatic calibration gas sequencing. The SPS 4001B is fully enclosed in a NEMA cabinet suited for wall-mounting. The sequencer performs autocalibrations based on the CALIBRATION RECOMMENDED signal from the Oxymitter 4000, a timed interval set up in HART, or whenever a calibration request is initiated.

## System Features

1. The CALIBRATION RECOMMENDED feature detects when the sensing cell is likely out of limits. This may eliminate the need to calibrate on a "time since last cal" basis.
2. The cell output voltage and sensitivity increase as the oxygen concentration decreases.

Figure 1-2. Oxymitter 4000  
AutoCalibration System Options

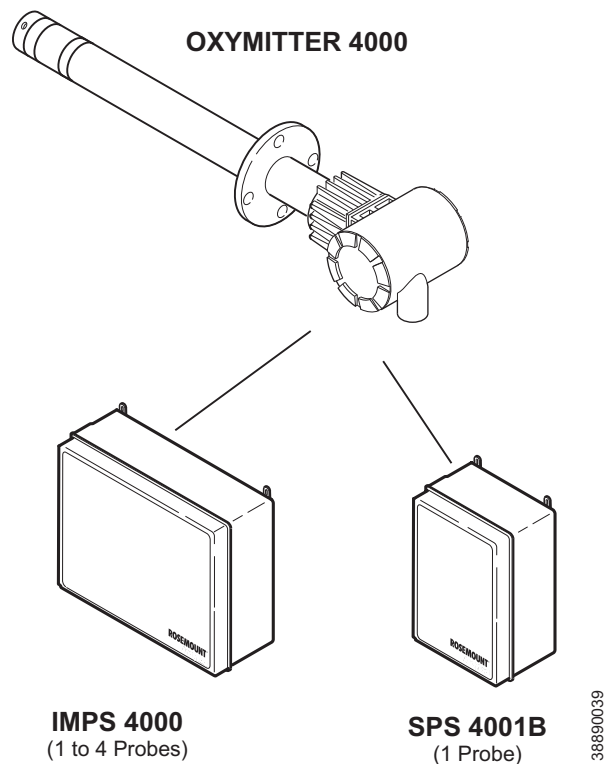

3. Membrane keypad, Figure 1-3, and HART communication are standard. To use the HART capability, you must have either:
  - a. HART Model 275/375 Communicator.
  - b. Asset Management Solutions (AMS) software for the PC.

Figure 1-3. Membrane Keypad

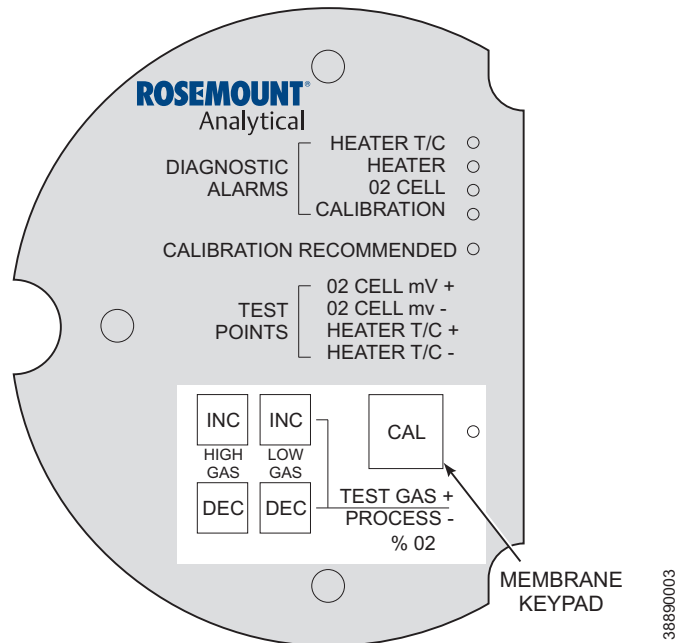

- An optional Local Operator Interface, Figure 1-4, allows continuous O<sub>2</sub> display and full interface capability.

Figure 1-4. Local Operator Interface (LOI)

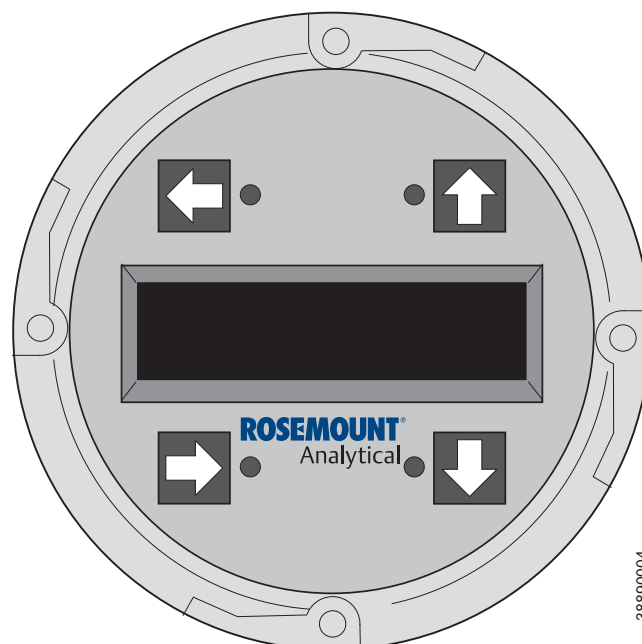

- Field replaceable cell, heater, thermocouple, and diffusion element.
- The Oxymitter 4000 is constructed of rugged 316 L stainless steel for all wetted parts.
- The electronics are adaptable for line voltages from 90-250 VAC; therefore, no configuration is necessary.



8. The Oxymitter 4000 membrane keypad is available in five languages:
  - English
  - French
  - German
  - Italian
  - Spanish
9. An operator can calibrate and diagnostically troubleshoot the Oxymitter 4000 in one of four ways:
  - a. Membrane Keypad. The membrane keypad, housed within the right side of the electronics housing, provides fault indication by way of flashing LEDs. Calibration can be performed from the membrane keypad.
  - b. LOI. The optional LOI takes the place of the membrane keypad and allows local communication with the electronics. Refer to Section 6 for more information.
  - c. Optional HART Interface. The Oxymitter 4000's 4-20 mA output line transmits an analog signal proportional to the oxygen level. The HART output is superimposed on the 4-20 mA output line. This information can be accessed through the following:
    - i. Rosemount Analytical Model 275/375 Handheld Communicator - The handheld communicator requires Device Description (DD) software specific to the Oxymitter 4000. The DD software will be supplied with many Model 275/375 units but can also be programmed into existing units at most Emerson Process Management service offices. See Section 7, HART/AMS, for additional information.
    - ii. Personal Computer (PC) - The use of a personal computer requires AMS software available from Emerson Process Management.
    - iii. Selected Distributed Control Systems - The use of distributed control systems requires input/output (I/O) hardware and AMS software which permit HART communications.
  - d. Optional IMPS 4000. The Programmable Logic Controller (PLC) in the IMPS 4000 provides fault indications using flashing LEDs and LCD display messages. Refer to the IMPS 4000 Intelligent Multiprobe Test Gas Sequencer Instruction Manual for more information.

# Oxymitter 4000

Figure 1-5. Model 751 LCD Display Panel

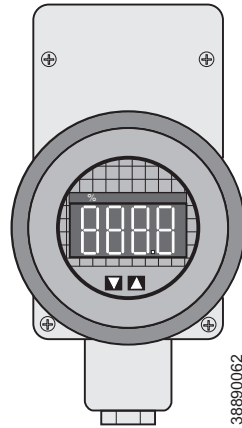

10. The optional Rosemount Analytical 751 remote-mounted LCD display panel shown in Figure 1-5 is loop-driven by the 4-20 mA output signal representing the O<sub>2</sub> percentage.
11. Optional OxyBalance Display and Averaging System. Reviews up to eight 4-20 mA signals from individual probes. Trends individual outputs, calculates four programmable averages as additional 4-20 mA outputs.

Figure 1-6. OxyBalance Display Displaying Outputs

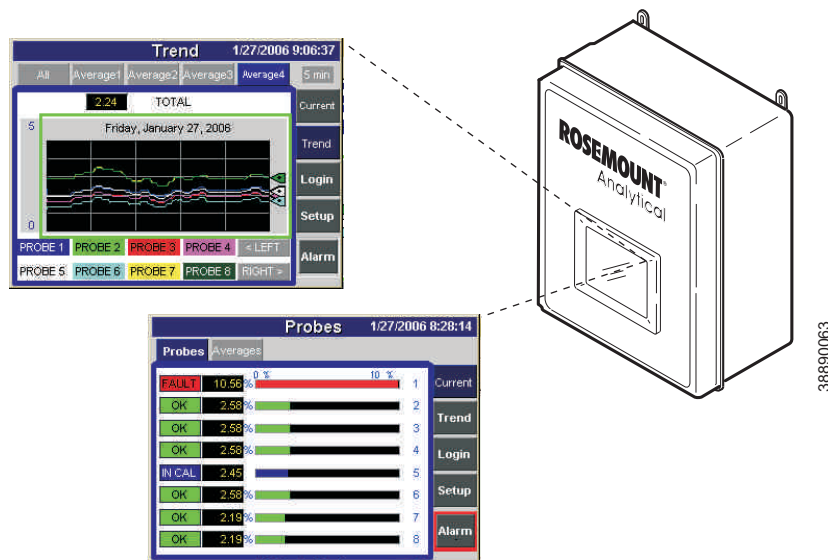

## Handling the Oxymitter 4000

### CAUTION

It is important that printed circuit boards and integrated circuits are handled only when adequate antistatic precautions have been taken to prevent possible equipment damage.

The Oxymitter 4000 is designed for industrial applications. Treat each component of the system with care to avoid physical damage. Some probe components are made from ceramics, which are susceptible to shock when mishandled.

Figure 1-7. Oxymitter 4000 HART Communications and AMS Application

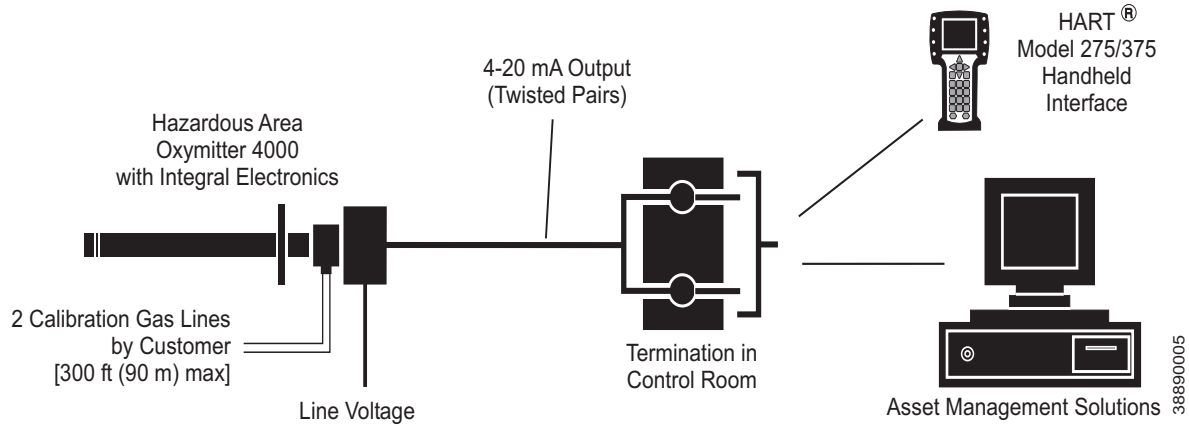

**System Considerations**

Prior to installing your Oxymitter 4000, make sure you have all the components necessary to make the system installation. Ensure all the components are properly integrated to make the system functional.

After verifying that you have all the components, select mounting locations and determine how each component will be placed in terms of available line voltage, ambient temperatures, environmental considerations, convenience, and serviceability.

Figure 1-7 shows a typical system wiring.

A typical system installation for an Oxymitter 4000 with integral electronics is shown in Figure 1-8. A typical system installation for an Oxymitter 4000 with remote electronics is shown in Figure 1-9.

A source of instrument air is optional at the Oxymitter 4000 for reference air use. Since the unit is equipped with an in place calibration feature, provisions can be made to permanently connect calibration gas bottles to the Oxymitter 4000.

If the calibration gas bottles will be permanently connected, a check valve is required next to the calibration fittings on the integral electronics.

This check valve is to prevent breathing of the calibration gas line and subsequent flue gas condensation and corrosion. The check valve is in addition to the stop valve in the calibration gas kit or the solenoid valves in the IMPS 4000 or SPS 4001B.

**NOTE:**

The electronics is rated NEMA 4X (IP66) and is capable of operation at temperatures up to 185°F (85°C).

The optional LOI is also rated for operation at temperatures up to 185°F (85°C). The infrared keypad functionality will degrade at temperatures above 158°F (70°C).

Retain the packaging in which the Oxymitter 4000 arrived from the factory in case any components are to be shipped to another site. This packaging has been designed to protect the product.

# Oxymitter 4000

Figure 1-8. Typical System Installation - Oxymitter 4000 with Integral Electronics

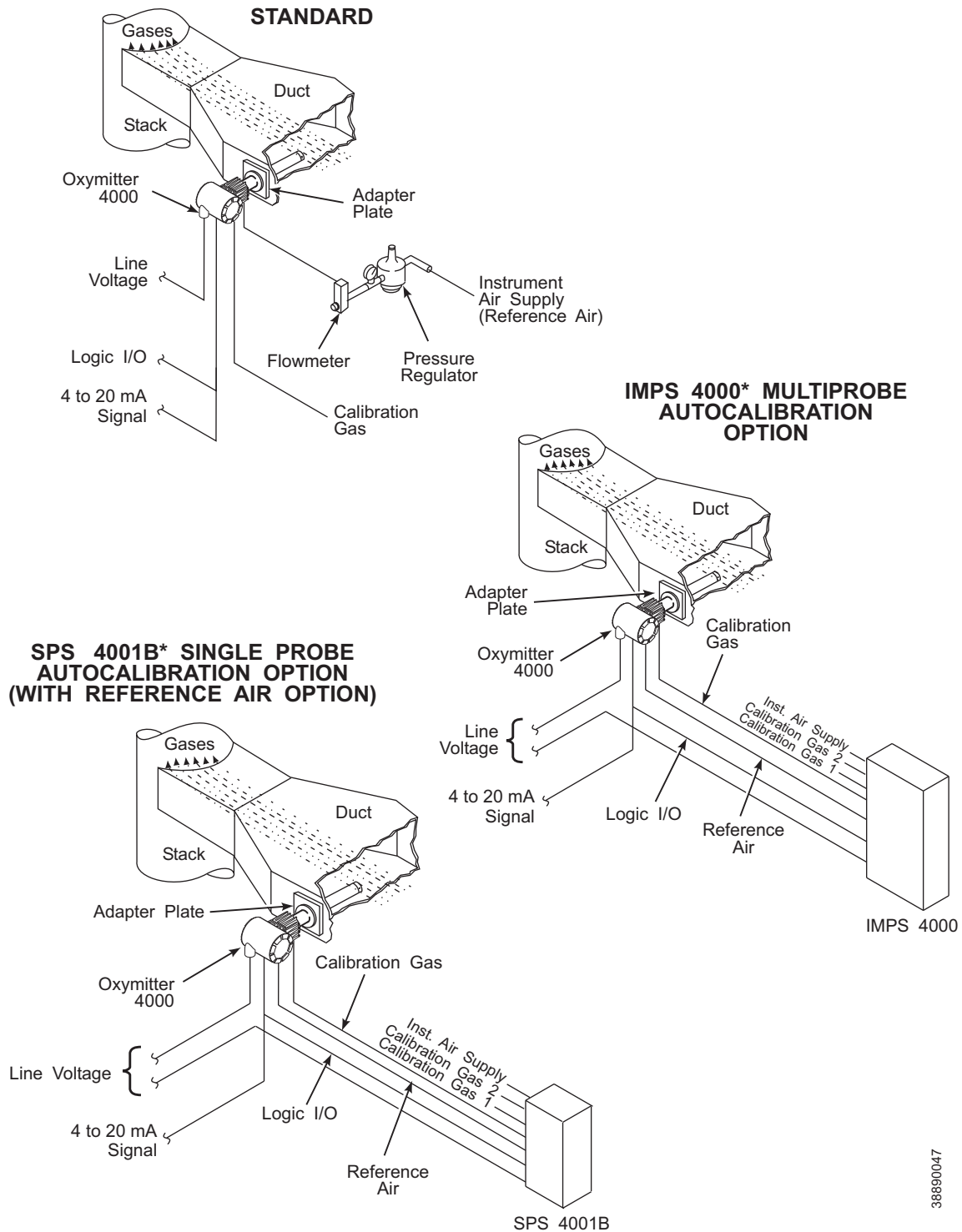

38890047

# Instruction Manual

IM-106-340, Rev. 4.2

July 2008

# Oxymitter 4000

Figure 1-9. Typical System Installation - Oxymitter 4000 with Remote Electronics

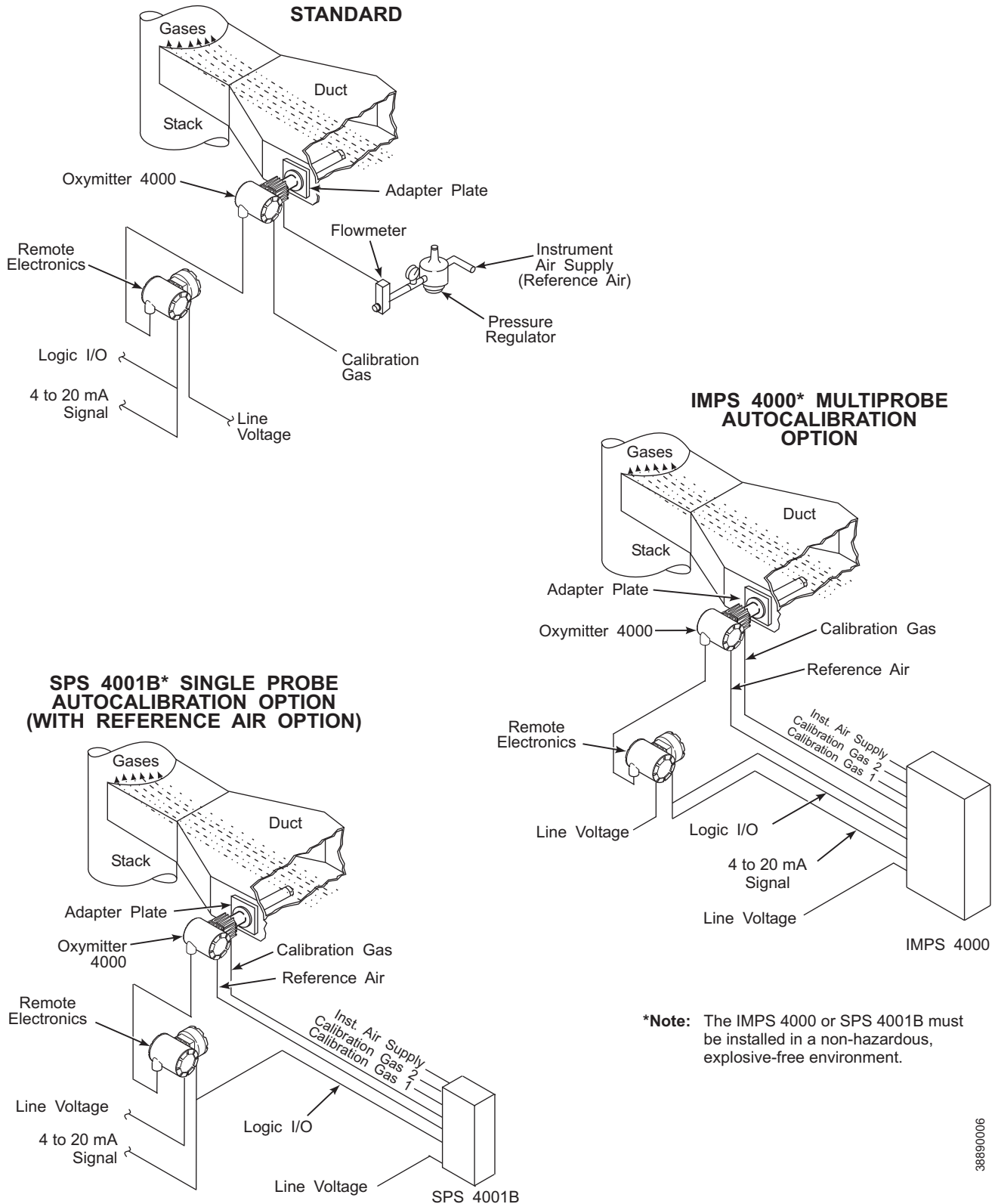

**\*Note:** The IMPS 4000 or SPS 4001B must be installed in a non-hazardous, explosive-free environment.

38890006

# Oxymitter 4000

---

## **IMPS 4000 (OPTIONAL)**

Information on the IMPS 4000 is available in the IMPS 4000 Intelligent Multiprobe Test Gas Sequencer Instruction Manual.

## **SPS 4001B (OPTIONAL)**

The SPS 4001B Single Probe Autocalibration Sequencer provides the capability of performing automatic, timed or on demand, calibrations of a single Oxymitter 4000 without sending a technician to the installation site.

## **Mounting**

The SPS 4001B is fully enclosed in a NEMA cabinet suited for wall-mounting. This cabinet provides added protection against dust and minor impacts. The SPS 4001B consists of a manifold and a calibration gas flowmeter. The manifold provides electrical feedthroughs and calibration gas ports to route power and signal connections and calibration gases to and from the sequencer. In addition, the manifold houses two calibration gas solenoids that sequence the gases to the Oxymitter 4000, a pressure switch that detects low calibration gas pressure, and two PC boards. A terminal strip housed within the terminal cover provides convenient access for all user connections.

Components optional to the SPS 4001B include a reference air flowmeter and pressure regulator. The reference air flowmeter indicates the flow rate of reference air continuously flowing to the Oxymitter 4000. The reference air pressure regulator ensures the instrument air (reference air) flowing to the Oxymitter 4000 is at a constant pressure [20 psi (138 kPa)]. The regulator also has a filter to remove particulates in the reference air and a drain valve to bleed the moisture that collects in the filter bowl.

Brass fittings and Teflon tubing are standard. Stainless steel fittings and tubing are optional. Also, disposable calibration gas bottles are available as an option or can be purchased through a local supplier.

## **Operation**

The SPS 4001B works in conjunction with the Oxymitter 4000's CALIBRATION RECOMMENDED feature to perform an autocalibration. This feature automatically performs a gasless calibration check every hour on the Oxymitter 4000. If a calibration is recommended and its contact output signal is set for "handshaking" with the sequencer, the Oxymitter 4000 sends a signal to the sequencer. The sequencer automatically performs a calibration upon receiving the signal. Thus, no human interface is required for the automatic calibration to take place. For further SPS 4001B information, refer to the SPS 4001B Single Probe Autocalibration Sequencer Instruction Manual.

**MODEL 751 REMOTE  
POWERED LOOP LCD  
DISPLAY**

The display (Figure 1-10) provides a simple, economical means to obtain accurate, reliable, and remote indication of important process variables. This display operates on the 4-20 mA line from the Oxymitter 4000. Refer to Model 751 remote powered loop LCD manual for calibration and wiring.

Figure 1-10. Model 751 Remote Powered Loop LCD Display

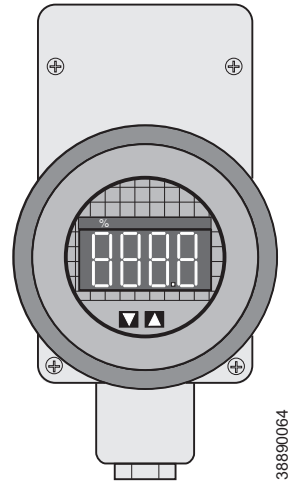

**PROBE OPTIONS**

**Diffusion Elements**

**Ceramic Diffusion Assembly**

The ceramic diffusion assembly, Figure 1-11, is the traditional design for the probe. Used for over 25 years, the ceramic diffusion assembly provides a greater filter surface area. This element is also available with a flame arrestor, and with a dust seal for use with an abrasive shield.

Figure 1-11. Ceramic Diffusion Assembly

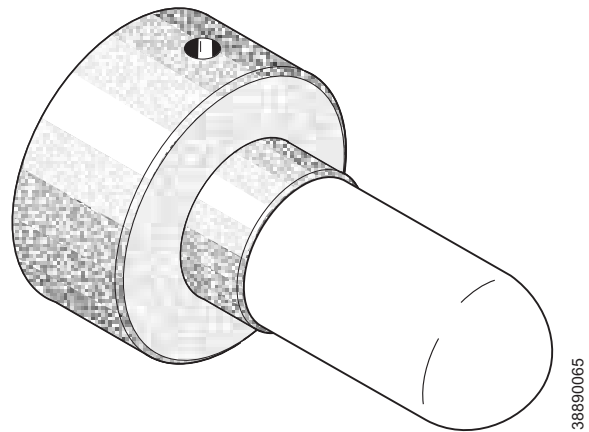

### Snubber Diffusion Assembly

The snubber diffusion assembly, Figure 1-12, is satisfactory for most applications. This element is also available with a flame arrestor, and with a dust seal for use with an abrasive shield.

Figure 1-12. Snubber Diffusion Assembly



### Cup-Type Diffusion Assembly

The cup-type diffusion assembly, Figure 1-13, is typically used in high temperature applications where frequent diffusion element plugging is a problem. It is available with either a 10 or 40 micron, sintered, Hastelloy element.

This element is also available with a dust seal for use with an abrasive shield.

Figure 1-13. Hastelloy Cup-Type Diffusion Assembly

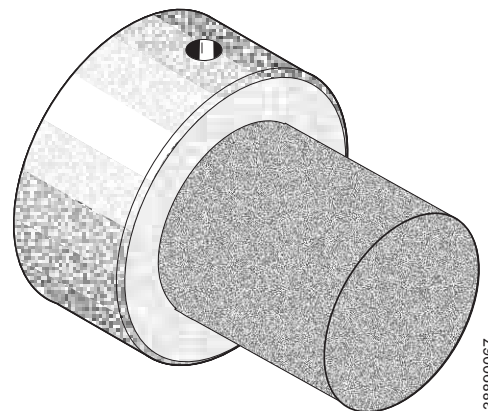

### Abrasive Shield Assembly

The abrasive shield assembly, Figure 1-14, is a stainless steel tube that surrounds the probe assembly. The shield protects against particle abrasion, provides a guide for ease of insertion, and acts as a position support, especially for longer probes. The abrasive shield assembly uses a modified diffuser and vee deflector assembly, fitted with dual dust seal packing.



Figure 1-14. Abrasive Shield Assembly

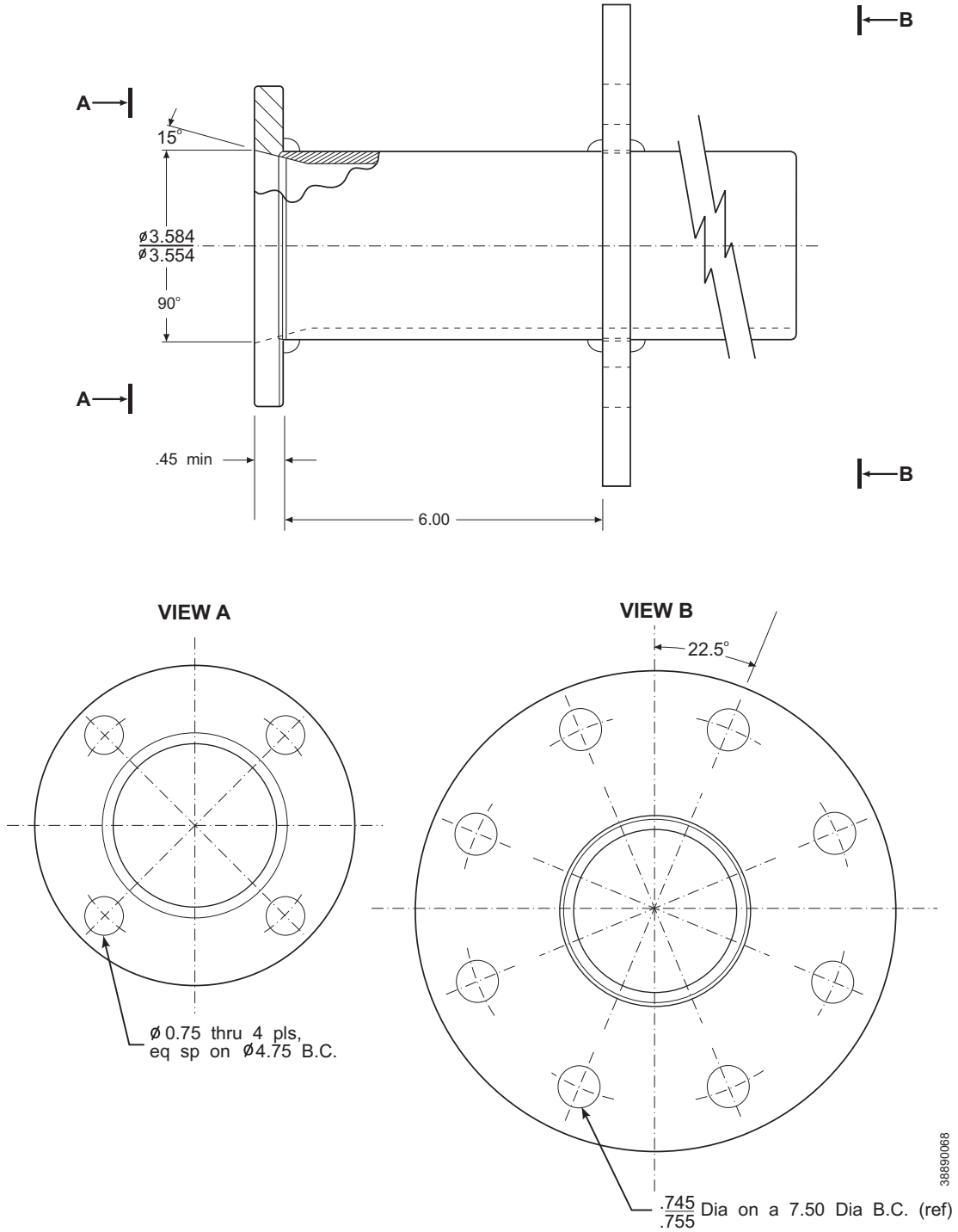

**NOTE**

In highly abrasive applications, rotate the shield 90 degrees at normal service intervals to present a new wear surface to the abrasive flow stream.

### SPECIFICATIONS

<b>Oxymitter Specifications</b>	
<b>O<sub>2</sub> Range</b>	
Standard	0 to 10% O <sub>2</sub> , 0 to 25% O <sub>2</sub> , 0 to 40% O <sub>2</sub> (via HART)
Accuracy	±0.75% of reading or 0.05% O <sub>2</sub> , whichever is greater
System Response to Calibration Gas	Initial – less than 3 seconds, T90 – less than 8 seconds
<b>Temperature Limits</b>	
Process	32° to 1300°F (0° to 704°C) up to 2400°F (1300°C) with optional accessories
Electronics Housing	-40° to 158°F (-40° to 70°C) ambient
Electronics Package	-40° to 185°F (-40° to 85°C) [Operating temperature of electronics inside of instrument housing, as measured by a HART communicator, Rosemount Analytical Asset Management Solutions software.]
Local Operator Interface	-40° to 158°F (-40° to 70° C), [above 158°F (70°C) the infrared keypad will cease to function, but the Oxymitter 4000 will continue to operate properly.]
Probe Lengths	18 in. (457 mm)                      12 ft (3,66 m) 3 ft (0,91 m)                            15 ft (4,57 m) 6 ft (1,83 m)                            18 ft (5,49 m) 9 ft (2,74 m)
Mounting and Mounting Position	Vertical or horizontal; a spool piece, (P/N 3D39761G02), is available to offset transmitter housing from hot ductwork.
<b>Materials</b>	
Probe	Wetted or welded parts - 316L stainless steel (SS) Non-wetted parts - 304 SS, low-copper aluminum
Electronics Enclosure	Low-copper aluminum
Calibration	Manual, semi-automatic, or automatic
Calibration Gas Mixtures Recommended	0.4% O <sub>2</sub> , Balance N <sub>2</sub> 8% O <sub>2</sub> , Balance N <sub>2</sub>
Calibration Gas Flow	2.5 l/min (5 scfh)
Reference Air	1 l/min (2 scfh), clean, dry, instrument-quality air (20.95% O <sub>2</sub> ), regulated to 34 kPa (5 psi)
Electronics	NEMA 4X, IP66 with fitting and pipe on reference exhaust port to clear dry atmosphere
Electric Noise	EN 61326-1, Class A
Certifications	General Purpose
	
Line Voltage	90-250 VAC, 48/62 Hz. No configuration necessary. 3/4 in. -14 NPT conduit port
<b>Table continued on next page</b>	

**Oxymitter Specifications**

## Signals

Analog Output/HART	4-20 mA isolated from power supply, 950 ohms maximum load
--------------------	---

Logic I/O	Two-terminal logic contact configurable as either an alarm output or as a bi-directional calibration handshake signal to IMPS 4000 or SPS 4001B, self-powered (+5 V) in series with 340 ohms Conduit ports — 3/4 in.-14 NPT (for analog output and logic I/O signal lines)
-----------	---

## Power Requirements:

Probe Heater	175 W nominal
--------------	---------------

Electronics	10 W nominal
-------------	--------------

Maximum	500 W
---------	-------

# Oxymitter 4000

Table 1-1. Product Matrix

OXT4A	Oxymitter 4000 In Situ Oxygen Transmitter					
Oxygen Transmitter - Instruction Book						
<b>Code</b>	<b>Sensing Probe Type</b>					
1	ANSI (N. American Std.) Probe with Ceramic Diffuser					
2	ANSI Probe with Flame Arrestor and Ceramic Diffuser					
3	ANSI Probe with Snubber Diffuser					
4	DIN (European Std.) Probe with Ceramic Diffuser					
5	DIN Probe with Flame Arrestor and Snubber Diffuser					
6	DIN Probe with Snubber Diffuser					
<b>Code</b>	<b>Probe Assembly</b>					
0	18 in. (457 mm) Probe					
1	18 in. (457 mm) Probe with Abrasive Shield <sup>(1)</sup>					
2	3 ft (0,91 m) Probe					
3	3 ft (0,91 m) Probe with Abrasive Shield <sup>(1)</sup>					
4	6 ft (1,83 m) Probe					
5	6 ft (1,83 m) Probe with Abrasive Shield <sup>(1)</sup>					
6	9 ft (2,74 m) Probe					
7	9 ft (2,74 m) Probe with Abrasive Shield <sup>(1)</sup>					
8	12 ft (3,66 m) Probe					
9	12 ft (3,66 m) Probe with Abrasive Shield <sup>(1)</sup>					
A	15 ft (4,57 m) Probe with Abrasive Shield <sup>(1)</sup>					
B	18 ft (5,49 m) Probe with Abrasive Shield <sup>(1)</sup>					
<b>Code</b>	<b>Mounting Hardware- Stack Side</b>					
0	No Mounting Hardware ("0" must be chosen under "Mounting Hardware - Probe Side" below)					
1	New Installation - Square weld plate with studs					
2	Mounting to Model 218 Mounting Plate (with Model 218 Shield Removed)					
3	Mounting to Existing Model 218 Support Shield					
4	Mounting to Other Mounting <sup>(2)</sup>					
5	Mounting to Model 132 Adapter Plate					
<b>Code</b>	<b>Mounting Hardware- Probe Side</b>					
0	No Mounting Hardware					
1	Probe Only (ANSI) (N. American Std.)					
2	New Bypass or New Abrasive Shield (ANSI)					
4	Probe Only (DIN)					
5	New Bypass or New Abrasive Shield (DIN)					
<b>Code</b>	<b>Electronic Housing &amp; Filtered Customer Termination - NEMA 4X, IP66</b>					
12	HART Integral Electronics, Transient Protected Filtered Termination, ATEX Certification					
14	Remote Electronics with Transient Protected Filtered Termination (requires cable)					
<b>OXT4C</b>	<b>3</b>	<b>3</b>	<b>1</b>	<b>1</b>	<b>12</b>	<b>Example</b>

# Instruction Manual

IM-106-340, Rev. 4.2

July 2008

# Oxymitter 4000

Cont'd

Code	Operator Interface <sup>(3)</sup>
1	HART with Membrane Keypad - blind cover
2	HART with Membrane Keypad - window cover
3	HART with Local Operation Interface, window cover, English only

Code	Language
1	English
2	German
3	French
4	Spanish
5	Italian

Code	Termination Filtering
00	Specified as part of Electronic Housing

Code	Calibration Accessories
00	No Hardware
01	Calibration Gas Flowmeter and Reference Air Set
02	Intelligent Multiprobe Sequencer (Refer to Table 1-3)

Code	Electronics to Probe Cable
00	No Cable
10	20 ft (6 m) Cable
11	40 ft (12 m) Cable
12	60 ft (18 m) Cable
13	80 ft (24 m) Cable
14	100 ft (30 m) Cable
15	150 ft (45 m) Cable
16	200 ft (61 m) Cable

Cont'd	1	3	00	01	00	Example
--------	---	---	----	----	----	---------

**NOTES:**

<sup>(1)</sup> Recommended uses: High velocity particulates in flue stream, installation within 11.5 ft (3.5 m) of soot blowers or heavy salt cake buildup. Applications: Pulverized coal, recovery boilers, lime kiln.

<sup>(2)</sup> Where possible, specify ANSI or DIN designation; otherwise, provide details of the existing mounting plate as follows:

Plate with studs	Bolt circle diameter, number, and arrangement of studs; stud thread; and stud height above mounting plate.
Plate without studs	Bolt circle diameter, number, and arrangement of holes; thread; and depth of stud mounting plate with accessories.

Table 1-2. Calibration Components

Part Number	Description
1A99119G01	Two disposable calibration gas bottles - 0.4% and 8% O <sub>2</sub> , balance nitrogen - 550 liters each*
1A99119G02	Two flow regulators for calibration gas bottles
1A99119G03	Bottle rack

*Notes:*

\*Calibration gas bottles cannot be shipped via airfreight.

When the bottles are used with CALIBRATION RECOMMENDED features, the bottles should provide 2 to 3 years of calibrations in normal service.

Table 1-3. Intelligent Multiprobe Test Gas Sequencer Versions

Part Number	Description	Number of Oxymitters
3D39695G01	IMPS	1
3D39695G02	IMPS	2
3D39695G03	IMPS	3
3D39695G04	IMPS	4
3D39695G05	IMPS w/115 V Heater	1
3D39695G06	IMPS w/115 V Heater	2
3D39695G07	IMPS w/115 V Heater	3
3D39695G08	IMPS w/115 V Heater	4
3D39695G09	IMPS w/220V Heater	1
3D39695G10	IMPS w/220V Heater	2
3D39695G11	IMPS w/220V Heater	3
3D39695G12	IMPS w/220V Heater	4

## Section 2 Configuration of Oxymitter 4000 with Membrane Keypad

---

Verify Installation .....	page 2-1
Logic I/O .....	page 2-5

---

### VERIFY INSTALLATION

**⚠ WARNING**

Install all protective equipment covers and safety ground leads before equipment startup. Failure to install covers and ground leads could result in serious injury or death.

### Mechanical Installation

Ensure the Oxymitter 4000 is installed correctly. See Section 3: Installation.

### Terminal Block Wiring

1. Remove cover (27) to expose terminal block (25).
2. Check the terminal block wiring (Figure 2-1). Be sure the power, 4-20 mA signal, and the logic outputs are properly connected and secure. To avoid a shock hazard, the power terminal cover must be installed. For units with remote electronics, check the terminal block wiring at the probe and at the remote electronics unit.
3. Install housing cover (27, Figure 9-3 or Figure 9-4) on terminal block (25).

# Oxymitter 4000

Figure 2-1. Electronics Housing  
Terminals and Membrane  
Keypad

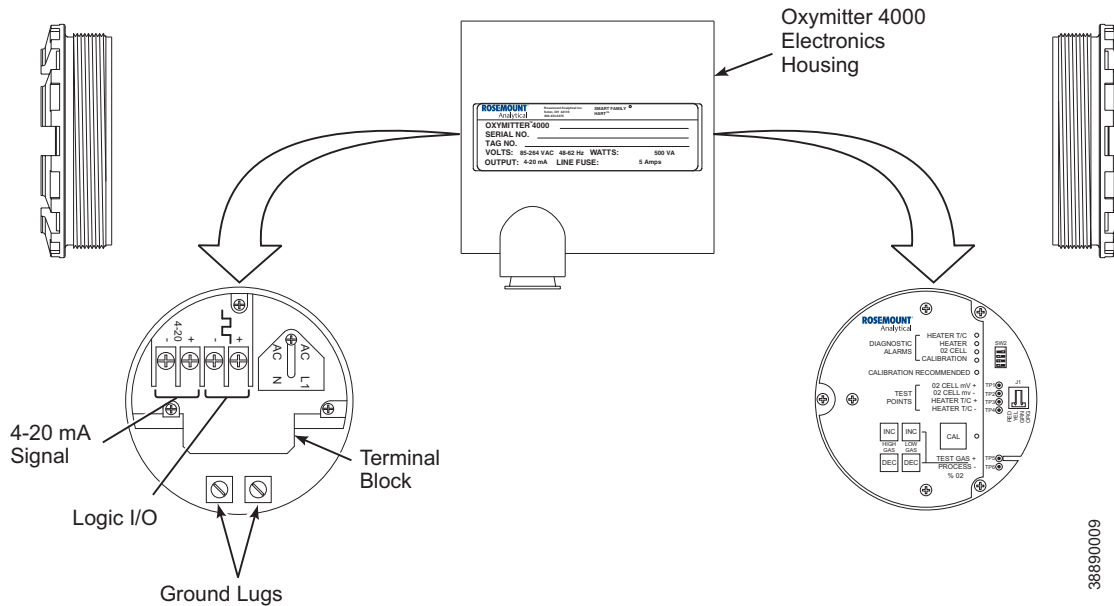

## Oxymitter 4000 Configuration

Located on the microprocessor board, the top board, are two switches that configure outputs for the Oxymitter 4000 (Figure 2-2). SW1 determines if the 4-20 mA signal is internally or externally powered. SW2 determines:

1. Oxymitter 4000 status, HART or LOCAL.
2. Oxygen range, 0 to 10% O<sub>2</sub> or 0 to 25% O<sub>2</sub>. (0 to 40% O<sub>2</sub> is also configurable only through HART/AMS.)
3. The 4-20 mA signal, at fault or power up, 3.5 mA or 21.6 mA.

### ⚠ CAUTION

Remove power from the Oxymitter 4000 before changing defaults. If defaults are changed under power, damage to the electronics package may occur.

### SW1 Setting

The two settings are internally or externally powering the 4-20 mA signal. The factory setting is for the 4-20 mA signal to be internally powered.



**SW2 Setting**

The factory sets this switch as follows:

1. Position 1 is HART/LOCAL. This switch setting controls the configuration of the Oxymitter 4000. The defaults cannot be changed via HART/AMS unless the switch is in the HART position. Placing SW2, position 1 in the LOCAL position forces the O<sub>2</sub> range to the setting of position 2. The position 1 switch must be placed in the LOCAL position or changes in SW2, position 2 will have no effect.
2. Position 2 determines the O<sub>2</sub> range. This can be set to either 0 to 10% O<sub>2</sub> or 0 to 25% O<sub>2</sub>. The factory setting is 0 to 10% O<sub>2</sub>. If necessary, the O<sub>2</sub> range can be configured from 0 to 40% O<sub>2</sub>. To select values within this range, set SW2, position 1 to HART and then enter the range via HART/AMS. Do not change SW2, position 1 to LOCAL unless you want to operate in the range specified by SW2, position 2.

**⚠ WARNING**

Typically, the probe's sensing cell, in direct contact with the process gases, is heated to approximately 1357°F (736°C). The external temperature of the probe body may exceed 842°F (450°C). If operating conditions also contain high oxygen levels and combustible gases, the Oxymitter 4000 may self-ignite.

3. Position 3 determines the output at startup or at an alarm. The settings are 3.5 mA or 21.6 mA. The factory setting is 3.5 mA. At startup, the current at the analog output is 3.5 mA or 21.6 mA.
4. Position 4 can be used to set the heater for 115 or 220 VAC operation. This switch is functional only when the software is set for manual voltage selection (Auto Tune = No). Otherwise, the internal electronics auto detect the input line voltage and sets the heater voltage accordingly (Auto Tune = Yes).

Figure 2-2. Defaults - Oxymitter 4000 with Membrane Keypad

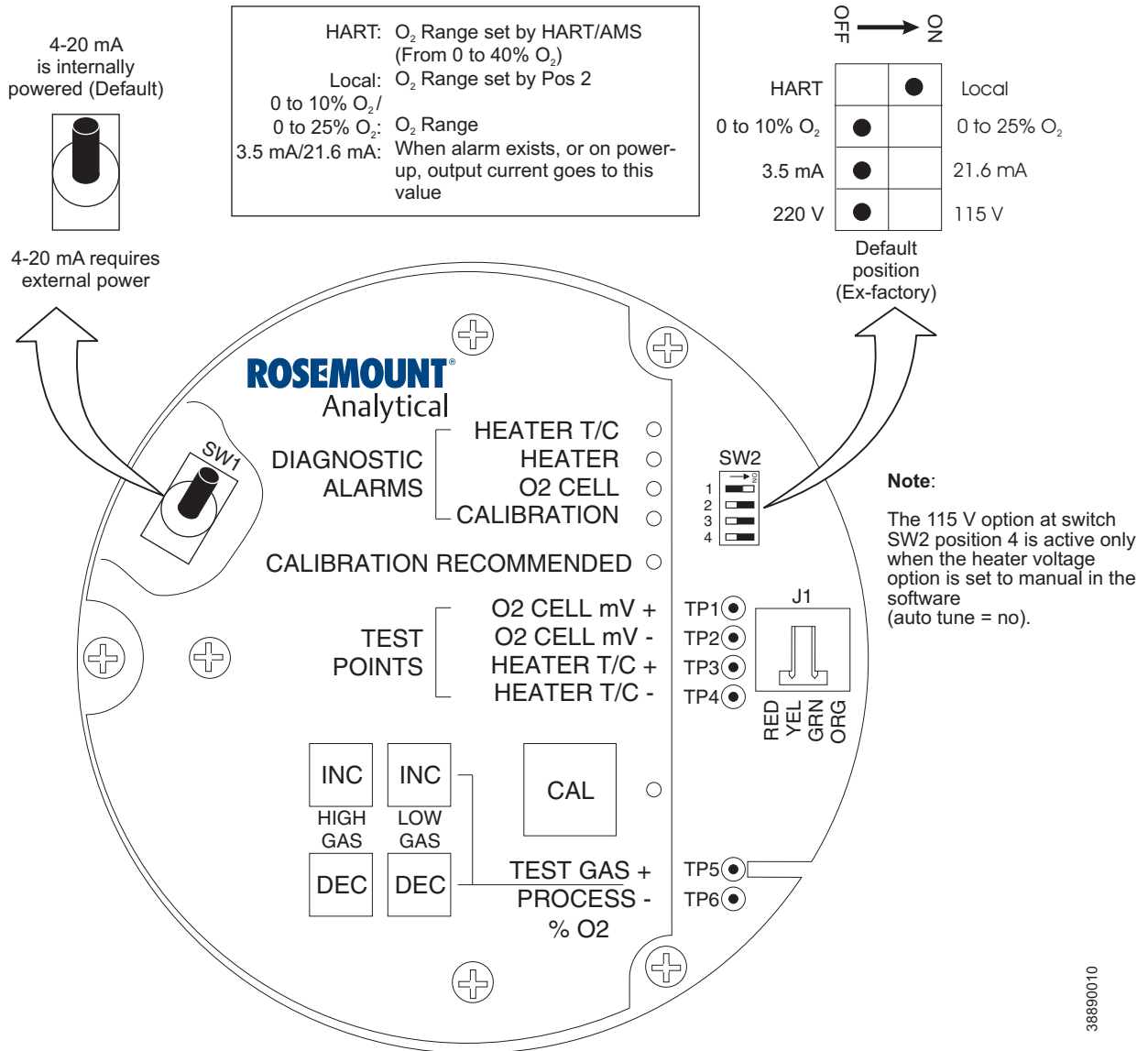

### Read O<sub>2</sub> Concentration

Once the cell is up to operating temperature, the O<sub>2</sub> percentage can be read:

1. Access TP5 and TP6 next to the membrane keypad. Attach a multimeter across TP5 and TP6. The calibration and process gases can now be monitored. Pressing the INC or DEC once will cause the output to switch from the process gas to the calibration gas. Pressing INC or DEC a second time will increase or decrease the calibration gas parameter. If the keys have been inactive for one minute, the output reverts to the process gas. If the keys have been inactive for one minute, the output reverts to the process gas.

When a calibration has been initiated, the value at TP5 and TP6 is the % O<sub>2</sub> seen by the cell.

Oxygen levels, as seen on the multimeter, are:  
 8.0% O<sub>2</sub> = 8.0 VDC  
 0.4% O<sub>2</sub> = 0.4 VDC

2. HART/AMS.
3. Model 751. The loop-driven LCD display.

**LOGIC I/O**

This two-terminal logic contact can be configured either as a solid-state relay-activated alarm or as a bi-directional calibration handshake signal to an IMPS 4000 or SPS 4001B. The configuration of this signal depends on the setting of the LOGIC I/O PIN MODE via HART/AMS or LOI. The ten different modes available are explained in Table 2-1.

Table 2-1. Logic I/O Configuration (as set at HART/AMS or LOI)

Mode	Configuration
0	The unit is not configured for any alarm condition.
1	The unit is configured for a Unit Alarm.
2	The unit is configured for Low O <sub>2</sub> .
3	The unit is configured for both a Unit Alarm and Low O <sub>2</sub> .
4	The unit is configured for a High AC Impedance/CALIBRATION RECOMMENDED.
5*	The unit is configured for both a Unit Alarm and a High AC Impedance/CALIBRATION RECOMMENDED.
6	The unit is configured for both a Low O <sub>2</sub> and High AC Impedance/CALIBRATION RECOMMENDED.
7	The unit is configured for a Unit Alarm, a Low O <sub>2</sub> , and a High AC Impedance/CALIBRATION RECOMMENDED.
8**	The unit is configured for a calibration handshake with IMPS 4000 or SPS 4001B. CALIBRATION RECOMMENDED will initiate the calibration cycle.
9	The unit is configured for a calibration handshake. CALIBRATION RECOMMENDED will not initiate the calibration cycle with the IMPS 4000 or SPS 4001B.

\*The default condition for an Oxymitter 4000 without an IMPS 4000 or SPS 4001B.  
 \*\*The default condition for an Oxymitter 4000 with an IMPS 4000 or SPS 4001B.

**Alarm**

When configured as an alarm, this signal alerts you to an out-of-spec condition. The output is 5 V in series with a 340 ohm resistor. For optimum performance, Emerson Process Management recommends connecting the output to a Potter & Brumfield 3.2 mA DC relay (P/N R10S-E1Y1-J1.0K).

Of the ten modes in Table 2-1, mode 1 through mode 7 are the alarm modes. The factory default is mode 5 for Oxymitter 4000 units without an IMPS 4000 or SPS 4001B. In this mode, the output will signal when a unit alarm or a CALIBRATION RECOMMENDED indication occurs.

## Calibration Handshake Signal

If using an optional IMPS 4000 or SPS 4001B, the logic I/O must be configured for calibration handshaking. Of the ten modes in Table 2-1, only modes 8 and 9 are configured for calibration handshaking. For an Oxymitter 4000 with an IMPS 4000 or an SPS 4001B, the factory sets the default to mode 8. In this mode, the logic I/O will be used to communicate between the Oxymitter 4000 and sequencer and to signal the sequencer when a CALIBRATION RECOMMENDATION indication occurs.

## Recommended Configuration

### 4-20 mA Signal Upon Critical Alarm

Emerson Process Management recommends that the factory default be utilized. The 4-20 mA signal will go to the 3.5 mA level upon any critical alarm which will cause the O<sub>2</sub> reading to be unusable. Customer can also select 21.6 mA as the failure setting if normal operations cause O<sub>2</sub> readings to go below the zero % O<sub>2</sub> (3.5 mA) level.

If the O<sub>2</sub> measurement is being utilized as part of an automatic control loop, the loop should be placed into manual upon this failure event or other appropriate action should be taken.

### Calibration

Emerson Process Management recommends utilizing an autocalibration system, actuated by the "calibration recommended" diagnostic. New O<sub>2</sub> cells may operate for more than a year, but older cells may require recalibration every few weeks as they near the end of their life. This strategy ensures that the O<sub>2</sub> reading is always accurate, and eliminates many unnecessary calibrations based on calendar days or weeks since previous calibration. When utilizing the SPS 4001B or IMPS 4000, consider wiring some or all associated alarm contacts.

1. CALIBRATION INITIATE. Contact from the control room to an SPS 4001B or IMPS 4000 (one per probe) provides the ability to manually initiate a calibration at any time from the control room. Note that calibrations can also be initiated from a HART handheld communicator, from Asset Management Solutions software, or from the keypad on the Oxymitter 4000.
2. IN CALIBRATION. One contact per probe provides notification to the control room that the "calibration recommended" diagnostic has initiated an automatic calibration through the SPS 4001B or IMPS 4000. If the O<sub>2</sub> signal is being utilized in an automatic control loop, this contact should be utilized to place the control loop into manual during calibration.
3. CALIBRATION FAILED. One contact per probe from an SPS 4001B or IMPS 4000 to the control room for notification that the calibration procedure failed. Grouped with this alarm is an output from a pressure switch which indicates when the calibration gas bottles are empty.
4. 4-20 mA SIGNAL DURING CALIBRATION. The 4-20 mA signal can be configured to respond normally during any calibration, or it can be configured to hold the last O<sub>2</sub> value upon the initiation of calibration. The factory default is for the 4-20 mA signal to operate normally throughout calibration. Holding the last O<sub>2</sub> value may be useful if several probes are being averaged for the purpose of automatic control. Unless several probes are being averaged, always place control loops that are using the O<sub>2</sub> signal into the manual mode prior to starting the calibration.

## Section 3 Installation

---

Mechanical Installation .....	page 3-2
Electrical Installation (with Integral Electronics) .....	page 3-10
Electrical Installation (with Remote Electronics) .....	page 3-13
Pneumatic Installation .....	page 3-16
IMPS 4000 Connections .....	page 3-18
SPS 4001B Connections .....	page 3-18

---

### WARNING

Before installing this equipment, read the "Safety instructions for the wiring and installation of this apparatus" at the front of this Instruction Manual. Failure to follow safety instructions could result in serious injury or death.

### WARNING

Install all protective equipment covers and safety ground leads after installation. Failure to install covers and ground leads could result in serious injury or death.

### WARNING

The Oxymitter 4000 (OXT4A) can be installed in general purpose areas only. Do not install the OXT4A in hazardous areas. For hazardous areas use the OXT4C.

# Oxymitter 4000

---

## MECHANICAL INSTALLATION

### Selecting Location

1. The location of the Oxymitter 4000 in the stack or flue is most important for maximum accuracy in the oxygen analyzing process. The Oxymitter 4000 must be positioned so the gas it measures is representative of the process. Best results are normally obtained if the Oxymitter 4000 is positioned near the center of the duct (40-60% insertion). Longer ducts may require several Oxymitter 4000 units since the O<sub>2</sub> can vary due to stratification. A point too near the wall of the duct, or the inside radius of a bend, may not provide a representative sample because of the very low flow conditions. The sensing point should be selected so the process gas temperature falls within a range of 32° to 1300°F (0° to 704°C). Figure 3-1 through Figure 3-8 provide mechanical installation references. The ambient temperature of the integral electronics housing must not exceed 185°F (85°C). For higher ambient temperatures, we recommend the remote mounted electronics option.
2. Check the flue or stack for holes and air leakage. The presence of this condition will substantially affect the accuracy of the oxygen reading. Therefore, either make the necessary repairs or install the Oxymitter 4000 upstream of any leakage.
3. Ensure the area is clear of internal and external obstructions that will interfere with installation and maintenance access to the membrane keypad or LOI. Allow adequate clearance for removal of the Oxymitter 4000.

#### **⚠ CAUTION**

Do not allow the temperature of the Oxymitter 4000 electronics to exceed 185°F (85°C) or damage to the unit may result.

### Probe Installation

1. Ensure all components are available to install the Oxymitter 4000. If equipped with the optional ceramic diffusion element, ensure it is not damaged.
2. The Oxymitter 4000 may be installed intact as it is received.

---

#### **NOTE**

An abrasive shield is recommended for high velocity particulates in the flue stream (such as those in coal-fired boilers, kilns, and recovery boilers). Vertical and horizontal brace clamps are provided for 9 ft and 12 ft (2,75 m and 3,66 m) probes to provide mechanical support for the Oxymitter 4000. Refer to Figure 3-6.

---

3. Weld or bolt adapter plate (Figure 3-5) onto the duct.
4. If using the optional ceramic diffusion element, the vee deflector must be correctly oriented. Before inserting the Oxymitter 4000, check the direction of gas flow in the duct. Orient the vee deflector so the apex points upstream toward the flow (Figure 3-7). This may be done by loosening the setscrews and rotating the vee deflector to the desired position. Retighten the setscrews.

# Instruction Manual

IM-106-340, Rev. 4.2

July 2008

# Oxymitter 4000

Figure 3-1. Oxymitter 4000 Probe Installation

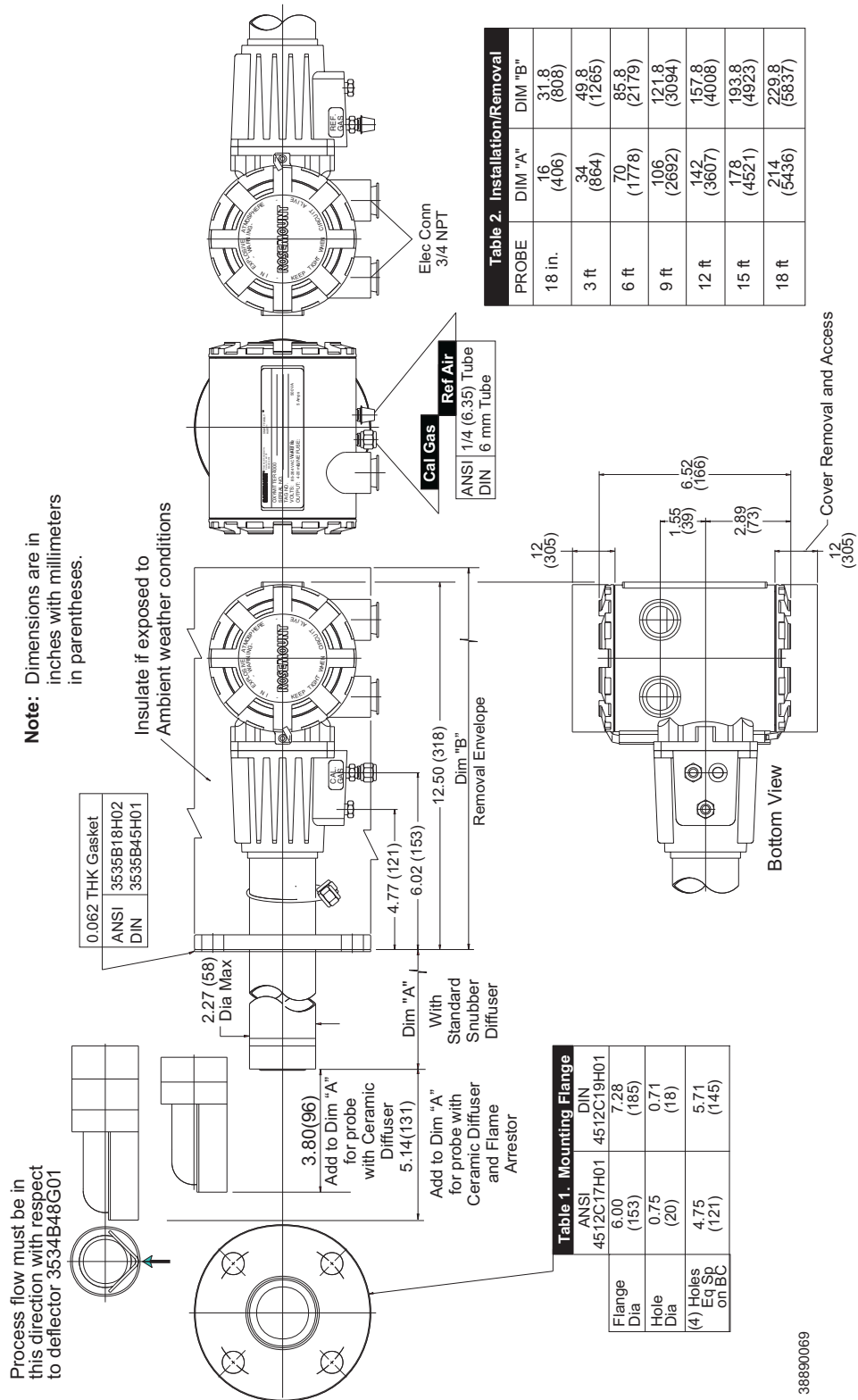

38890069

# Oxymitter 4000

Figure 3-2. Oxymitter 4000  
Remote Electronics Installation

### REMOTE ELECTRONICS WITH MEMBRANE KEYPAD AND BLIND COVER

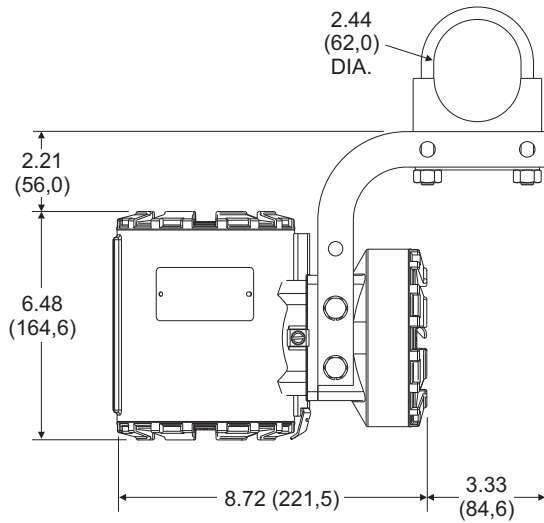

### REMOTE ELECTRONICS WITH LOI AND WINDOW COVER

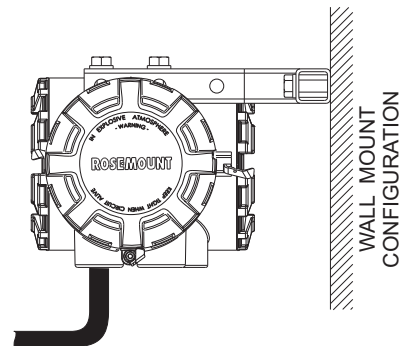
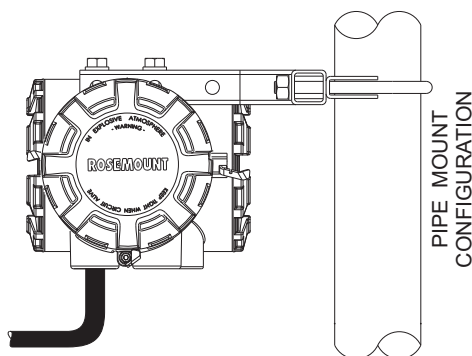
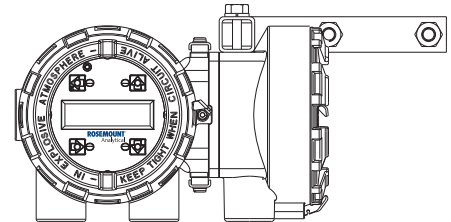
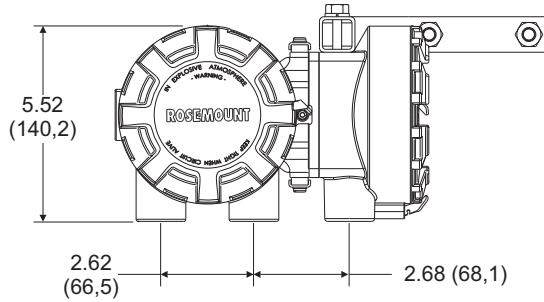
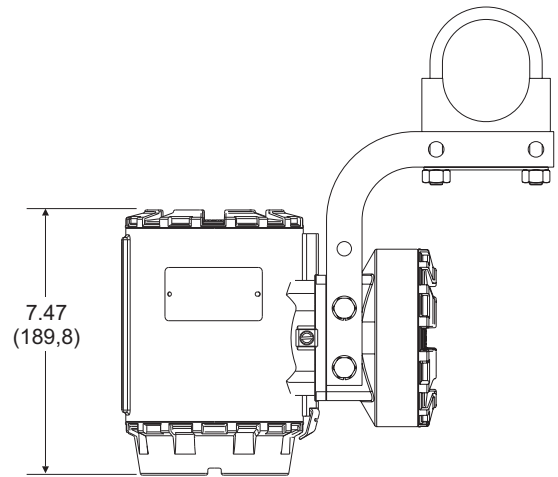

**Note:** Dimensions are in inches with millimeters in parentheses.

38890046



Figure 3-3. Oxymitter 4000 with Abrasive Shield

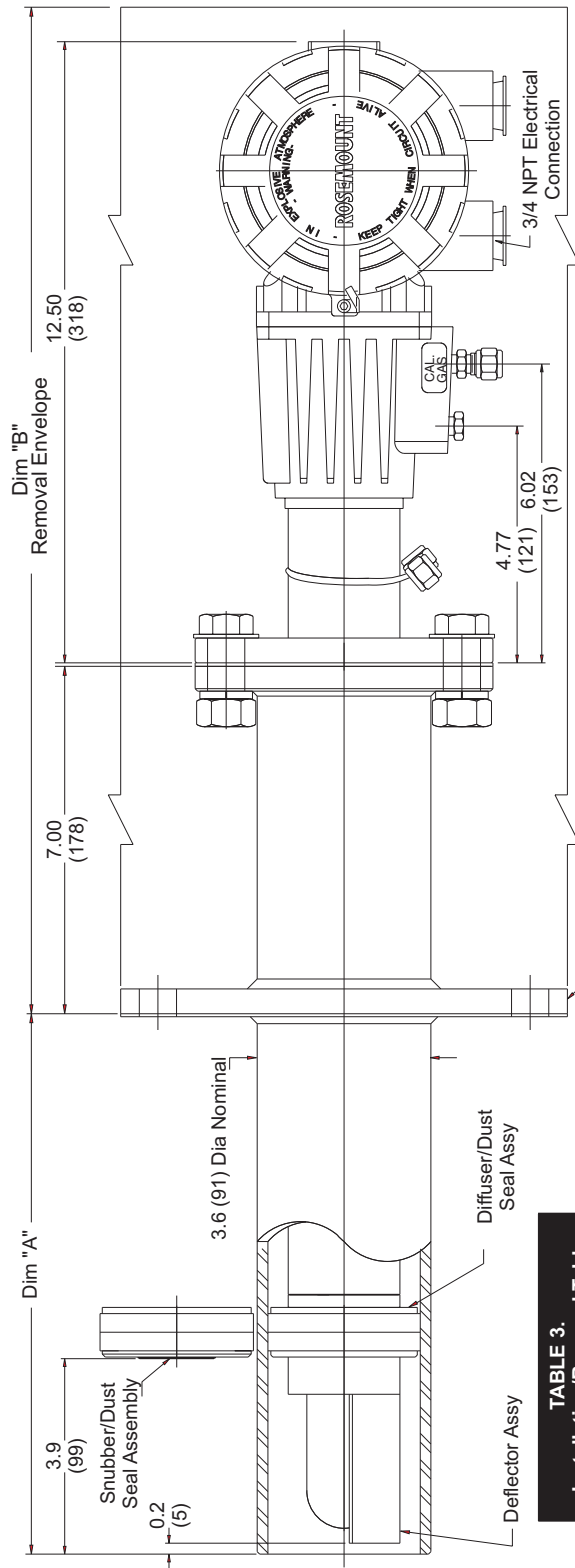

**Notes:**

1. These flat-faced flanges are manufactured to ANSI, and DIN bolt patterns and are not pressure rated.
2. Dimensions are in inches with millimeters in parentheses.

Cal Gas*	
Ref Air	
ANSI	1/4 in. Tube
DIN	6 mm Tube

\*Add check valve in Cal Gas line

Flange	ANSI	DIN
Flange Dia	9.00 (229)	9.25 (235)
Hole Dia	0.75 (19)	0.94 (24)
(8) Holes Eq Sp on BC	7.50 (190)	7.48 (190)

Probe	Dim "A"	Dim "B"
18 in.	13 (330)	32.5 (826)
3 ft	31 (787)	50.5 (1283)
6 ft	67 (1702)	86.5 (2197)
9 ft	103 (2616)	122.5 (3112)
12 ft	139 (3531)	158.5 (4026)
15 ft	175 (4445)	194.5 (4940)
18 ft	211 (5359)	230.5 (5855)

38890070

Figure 3-4. Oxymitter 4000 Adapter Plate Dimensions

### ADAPTOR PLATE OUTLINE

Dimensions in. (mm)	ANSI (P/N 4512C34G01)	DIN (P/N 4512C36G01)
"A"	6.00 (153)	7.5 (191)
"B" Thread	0.625-11	(M-16 x 2)
"C" Dia	4.75 (121)	5.708 (145)

\*Part numbers for adapter plates include attaching hardware.

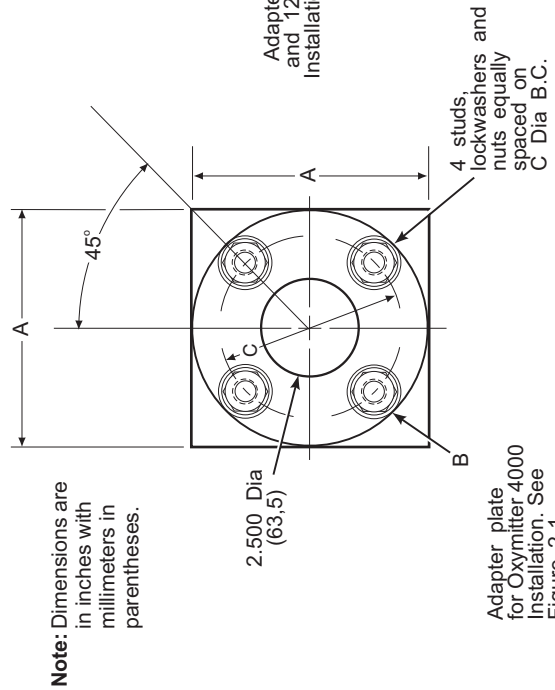

Dimensions in. (mm)	ANSI (P/N 3535B58G02)	DIN (P/N 3535B58G06)
"A"	9.00 (229)	9.25 (235)
"B" Dia	4.75 (121)	3.94 (100)
"C" Thread	0.625-11	(M-16 x 2)
"D" Dia	7.50 (191)	7.48 (190)

\*Part numbers for adapter plates include attaching hardware.

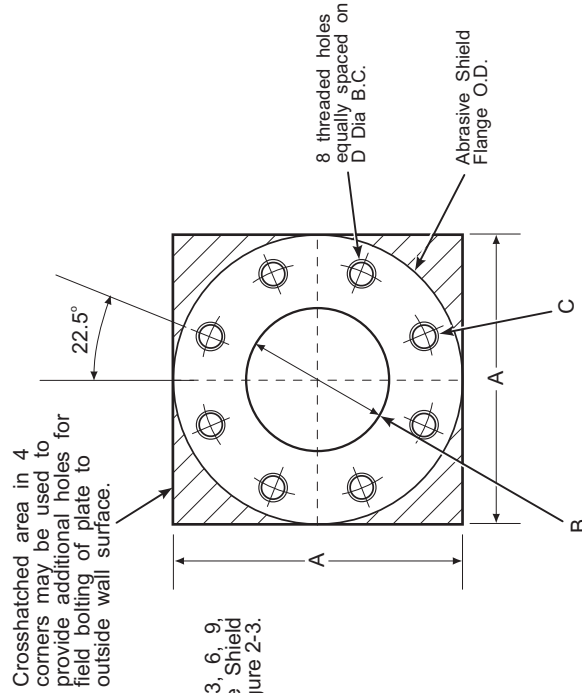
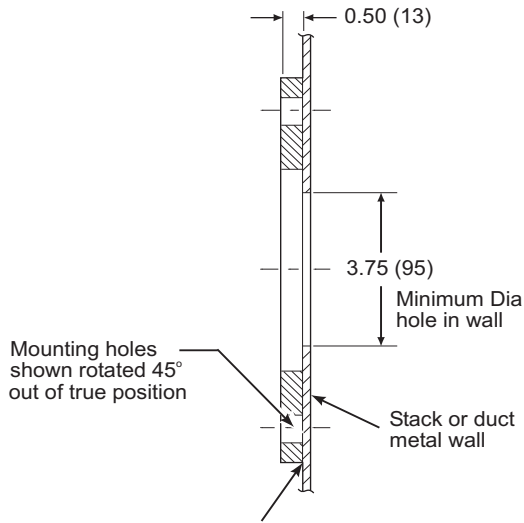
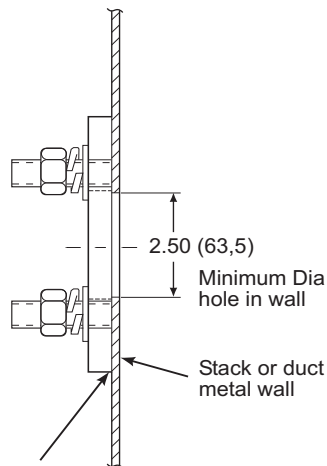

Figure 3-5. Oxymitter 4000  
Adapter Plate Installation

**INSTALLATION FOR METAL WALL  
STACK OR DUCT CONSTRUCTION**



Weld or bolt mounting plate to metal wall of stack or duct; Joint must be air tight.



Weld or bolt adapter plate to metal wall of stack or duct. Joint must be air tight.

**INSTALLATION FOR MASONRY  
WALL STACK CONSTRUCTION**

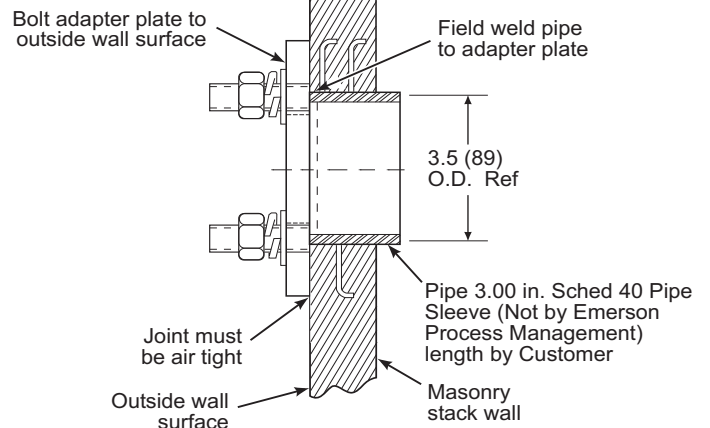
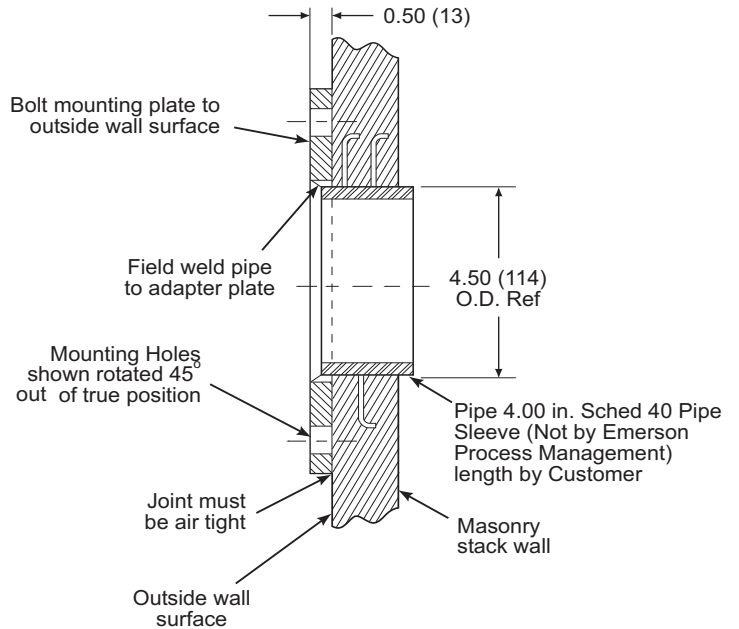

- Notes:**
1. Dimensions are in inches with millimeters in parentheses.
  2. All masonry stack work and joints except adaptor plate are not furnished by Emerson Process Management.

38890072

Figure 3-6. Oxymitter 4000 Abrasive Shield Bracing Installation

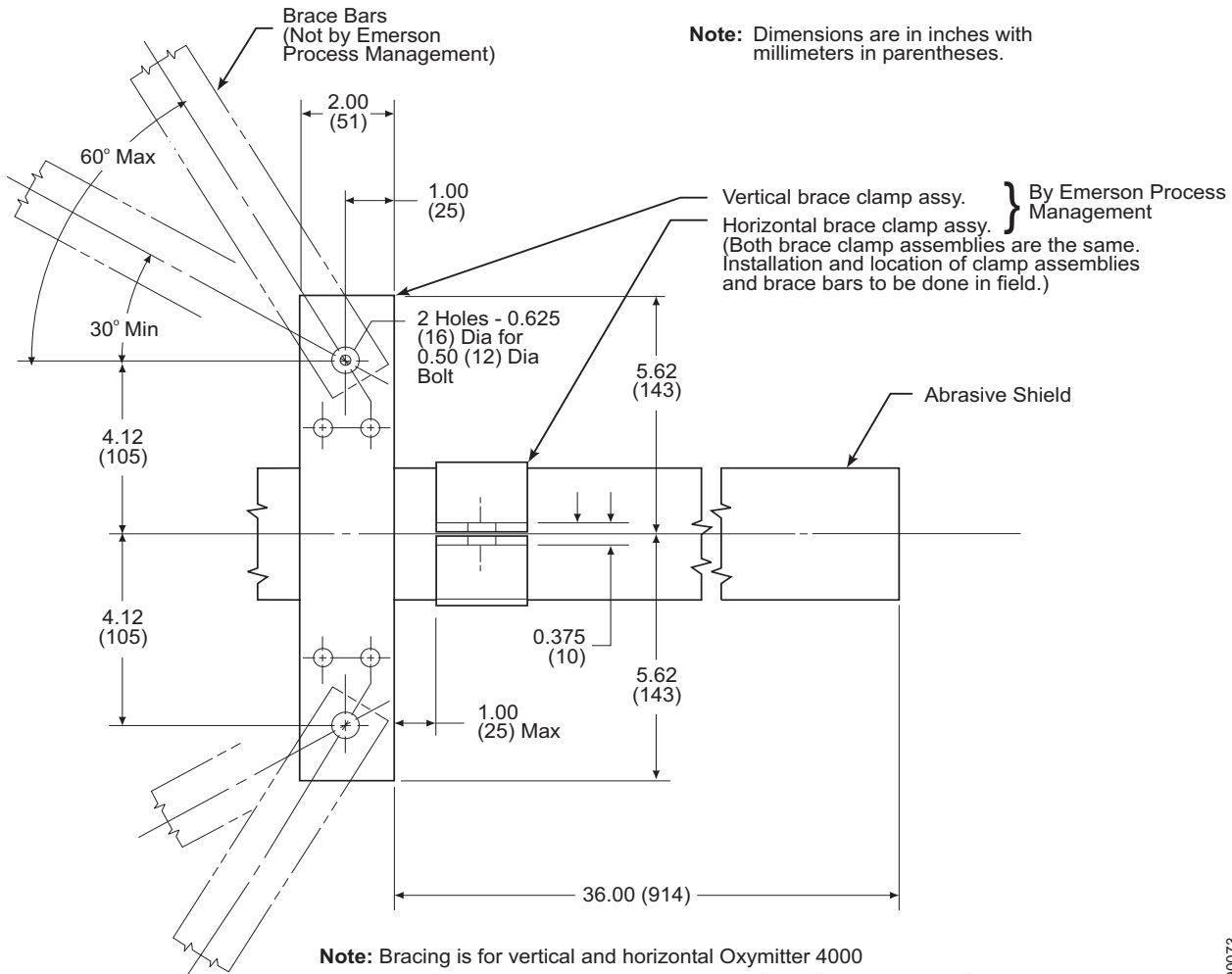

**Note:** Bracing is for vertical and horizontal Oxymitter 4000 Installation. External bracing required for 9 ft. through 18 ft. (2,75 m through 5,49 m) probes as shown above.

38890073

5. In vertical installations, ensure the system cable drops vertically from the Oxymitter 4000 and the conduit is routed below the level of the electronics housing. This drip loop minimizes the possibility that moisture will damage the electronics (Figure 3-8).
6. If the system has an abrasive shield, check the dust seal gaskets. The joints in the two gaskets must be staggered 180°. Also, make sure the gaskets are in the hub grooves as the Oxymitter 4000 slides into the 15° forcing cone in the abrasive shield.
7. Insert probe through the opening in the mounting flange and bolt the unit to the flange. When probe lengths selected are 9 to 18 ft (2.74 to 5.49 m), special brackets are supplied to provide additional support for the probe inside the flue or stack (Figure 3-6).

### NOTE

If process temperatures will exceed 392°F (200°C), use anti-seize compound on stud threads to ease future removal of Oxymitter 4000. For ambient temperatures that will exceed 185°F (85°C), we recommend the remote mounted electronics option.

Figure 3-7. Orienting the Optional Vee Deflector

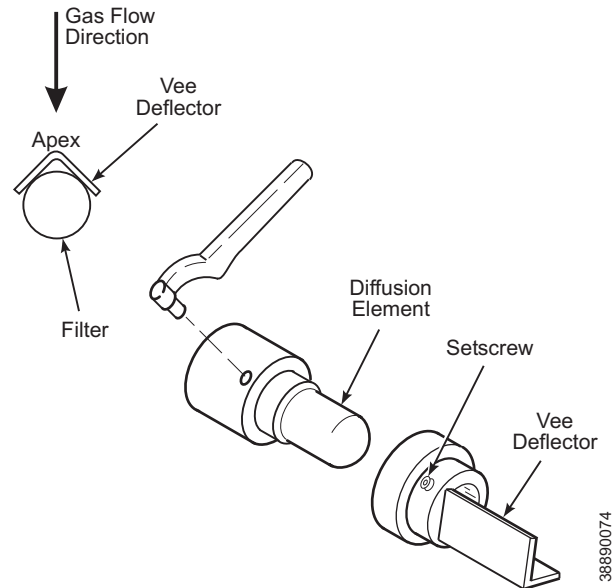

**CAUTION**

Uninsulated stacks or ducts may cause ambient temperatures around the electronics to exceed 185°F (85°C), which may cause overheating damage to the electronics.

8. If insulation is being removed to access the duct work for Oxymitter 4000 mounting, make sure the insulation is replaced afterward (Figure 3-8).

**Remote Electronics Installation**

For an Oxymitter 4000 equipped with remote electronics, install the probe according to the instructions in "Probe Installation". Install the remote electronics unit on a stand pipe or similar structure, Figure 3-2.

Figure 3-8. Installation with Drip Loop and Insulation Removal

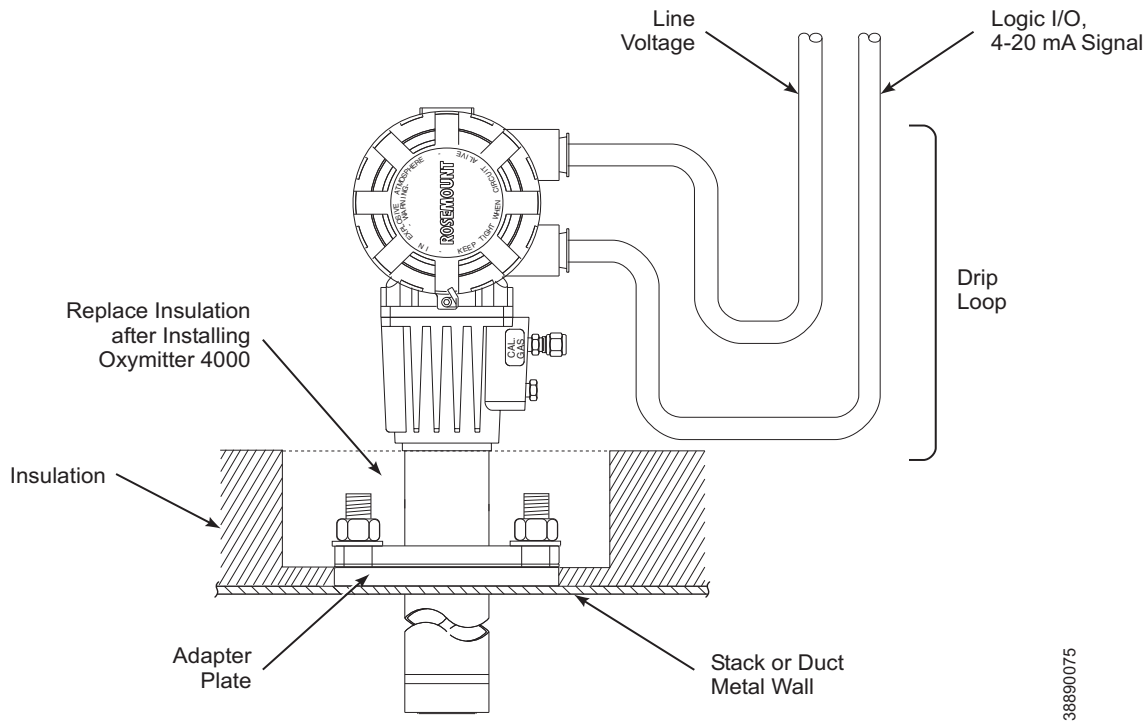

## ELECTRICAL INSTALLATION (WITH INTEGRAL ELECTRONICS)

### For Oxymitter 4000 with Integral Electronics

All wiring must conform to local and national codes.

#### **⚠ WARNING**

Disconnect and lock out power before connecting the power supply.

#### **⚠ WARNING**

Install all protective covers and safety ground leads after installation. Failure to install covers and ground leads could result in serious injury or death.

#### **⚠ WARNING**

To meet the Safety Requirements of IEC 1010 (EC requirement), and ensure safe operation of this equipment, connection to the main electrical power supply must be made through a circuit breaker (min 10 A) which will disconnect all current-carrying conductors during a fault situation. This circuit breaker should also include a mechanically operated isolating switch. If not, then another external means of disconnecting the supply from the equipment should be located close by. Circuit breakers or switches must comply with a recognized standard such as IEC 947.

**NOTE**

To maintain proper earth grounding, ensure a positive connection exists between the sensor housing, the electronics housing, and earth. The connecting ground wire must be 14 AWG minimum. Refer to Figure 3-9.

---

**NOTE**

Line voltage, signal, and relay wiring must be rated for at least 221°F (105°C).

---

1. Remove cover (27).
2. Connect Line Voltage.
  - a. Connect the line, or L1 wire to the L1 terminal and the neutral, or L2 wire, to the N terminal (Figure 3-9). The Oxymitter 4000 automatically will configure itself for 90-250 VAC line voltage and 50/60 Hz. The power supply requires no setup.
3. Connect 4-20 mA Signal and Calibration Handshake/Logic I/O Leads. Use individual shielded twisted wire pairs. Terminate the shield only at the electronics housing.
  - a. 4-20 mA Signal. The 4-20 mA signal represents the O<sub>2</sub> value and can also operate the Model 751 Remote Powered Loop LCD Display or any other loop powered display. Superimposed on the 4-20 mA signal is HART information that is accessible through a Model 275/375 Handheld Communicator or AMS software.
  - b. Calibration Handshake/Logic I/O. The output can either be an alarm or provide the handshaking to interface with an IMPS 4000 or SPS 4001B. For more information, refer to "Logic I/O" in Section 4: Configuration of Oxymitter 4000 with LOI, and either the IMPS 4000 Intelligent Multiprobe Test Gas Sequencer Instruction Manual or the SPS 4001B Single Probe Autocalibration Sequencer Instruction Manual.
  - c. If autocalibration is not utilized, a common bi-directional logic contact is provided for any of the diagnostic alarms listed in Table 8-1. The assignment of alarms which can actuate this contact can be modified to one of seven additional groupings listed in Table 2-1 and Table 4-1.

The logic contact is self-powered, +5 VDC, 340 ohm series resistance. An interposing relay will be required if this contact is to be utilized to annunciate a higher voltage device, such as a light or horn, and may also be required for certain DCS input cards. A Potter & Brumfield R10S-E1Y1-J1.0K 3.2 mA DC or an equal interposing relay will be mounted where the contact wires terminate in the control/relay room.
- d. Install cover (27, Figure 9-3).

Figure 3-9. Electrical Installation - Oxymitter 4000 with Integral Electronics

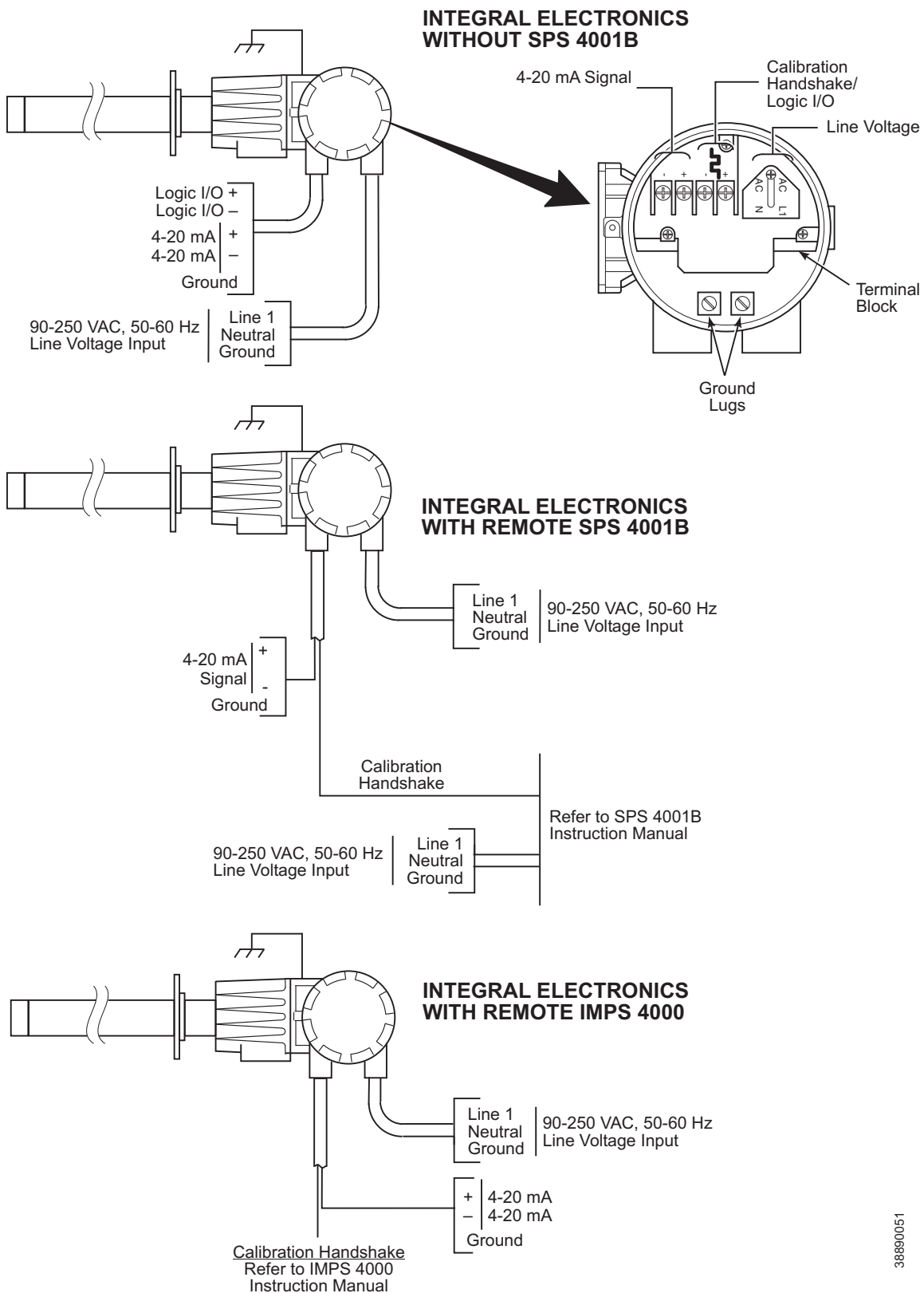

38890051



**ELECTRICAL  
INSTALLATION (WITH  
REMOTE  
ELECTRONICS)**

**For Oxymitter 4000 with Remote Electronics**

All wiring must conform to local and national codes.

**⚠ WARNING**

Disconnect and lock out power before connecting the power supply.

**⚠ WARNING**

Install all protective covers and safety ground leads after installation. Failure to install covers and ground leads could result in serious injury or death.

**⚠ WARNING**

To meet the Safety Requirements of IEC 1010 (EC requirement), and ensure safe operation of this equipment, connection to the main electrical power supply must be made through a circuit breaker (min 10 A) which will disconnect all current-carrying conductors during a fault situation. This circuit breaker should also include a mechanically operated isolating switch. If not, then another external means of disconnecting the supply from the equipment should be located close by. Circuit breakers or switches must comply with a recognized standard such as IEC 947.

**NOTE**

To maintain proper earth grounding, ensure a positive connection exists between the sensor housing, the electronics housing, and earth. The connecting ground wire must be 14 AWG minimum. Refer to Figure 3-10.

**NOTE**

Line voltage, signal, and relay wiring must be rated for at least 221°F (105°C).

1. Remove cover (27) from remote electronics.
2. Connect Line Voltage.
  - a. Connect the line, or L1 wire to the L1 terminal and the neutral, or L2 wire, to the N terminal (Figure 3-10). The Oxymitter 4000 automatically will configure itself for 90-250 VAC line voltage and 50/60 Hz. The power supply requires no setup.
3. Connect 4-20 mA Signal and Calibration Handshake/Logic I/O Leads (Figure 3-10). Use individual shielded twisted wire pairs. Terminate the shield only at the electronics housing.
  - a. 4-20 mA Signal. The 4-20 mA signal represents the O<sub>2</sub> value and can also operate the Model 751 Remote Powered Loop LCD Display or any other loop powered display. Superimposed on the 4-20 mA signal is HART information that is accessible through a Model 275/375 Handheld Communicator or AMS software.

b. Calibration Handshake/Logic I/O. The output can either be an alarm or provide the handshaking to interface with an IMPS 4000 or SPS 4001B. For more information, refer to "Logic I/O" in Section 4: Configuration of Oxymitter 4000 with LOI, and either the IMPS 4000 Intelligent Multiprobe Test Gas Sequencer Instruction Manual or the SPS 4001B Single Probe Autocalibration Sequencer Instruction Manual.

c. If autocalibration is not utilized, a common bi-directional logic contact is provided for any of the diagnostic alarms listed in Table 8-1. The assignment of alarms which can actuate this contact can be modified to one of seven additional groupings listed in Table 4-1.

The logic contact is self-powered, +5 VDC, 340 ohm series resistance. An interposing relay will be required if this contact is to be utilized to annunciate a higher voltage device, such as a light or horn, and may also be required for certain DCS input cards. A Potter & Brumfield R10S-E1Y1-J1.0K 3.2 mA DC or an equal interposing relay will be mounted where the contact wires terminate in the control/relay room.

4. Install cover (27, Figure 9-4).

5. Install Interconnecting Cable.

a. Remove cover (3) from junction box (5). Connect the electronics end of the interconnecting cable to the "FROM PROBE" side of the terminal block (Figure 3-10).

b. Remove housing cover (27).

c. Connect the heater power leads, the thermocouple leads and the oxygen signal leads at the terminal block. The leads are tagged for polarity.

# Instruction Manual

IM-106-340, Rev. 4.2  
July 2008

# Oxymitter 4000

Figure 3-10. Electrical Installation - Oxymitter 4000 with Remote Electronics

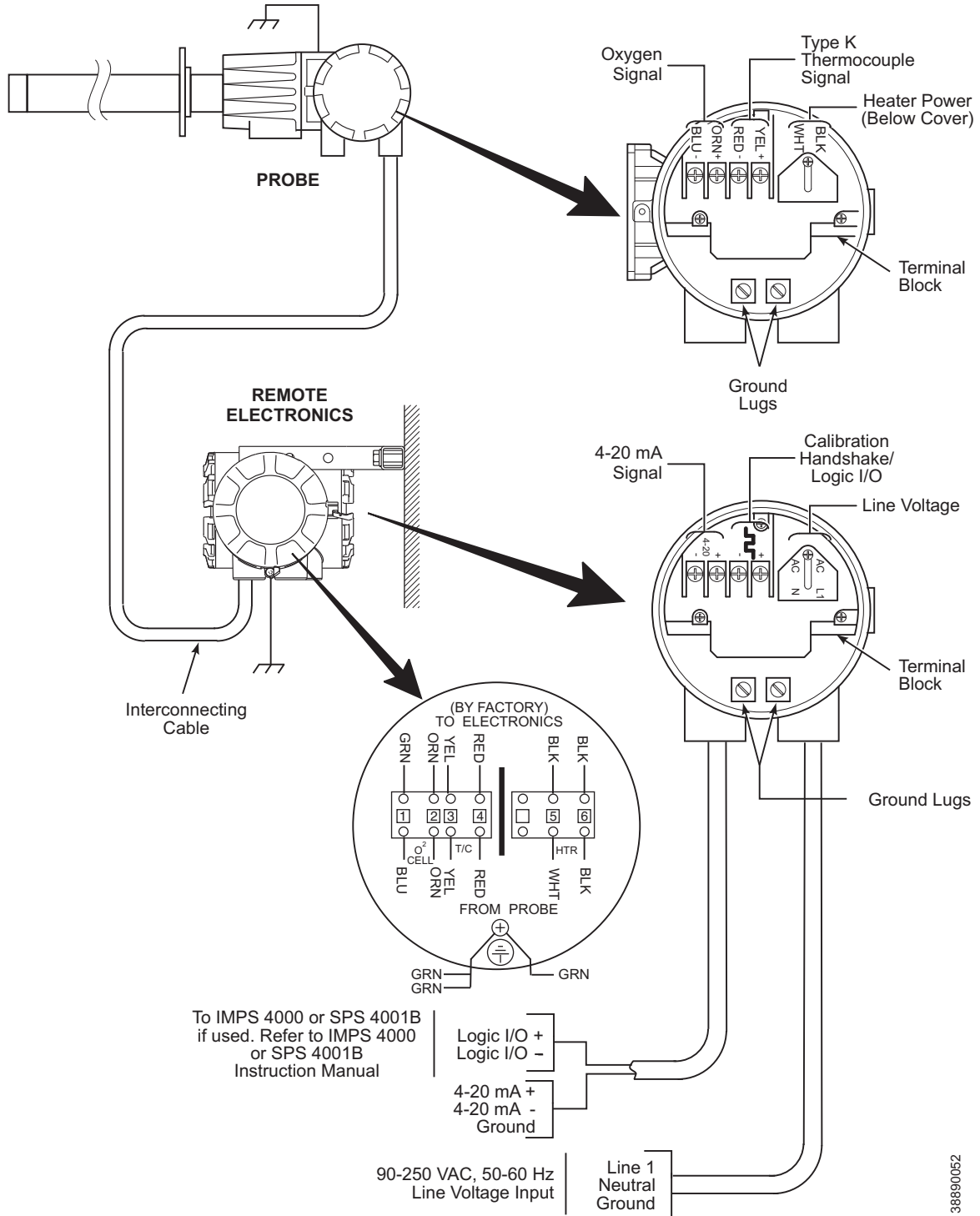

## Install Interconnecting Cable

### NOTE

If interconnect cable was not purchased with the Oxymitter 4000, consult the factory for the proper wire type and gauge.

1. Remove cover (27, Figure 9-4) from junction box (5). Connect the electronics end of the interconnecting cable (9) to the "FROM PROBE" side of terminal block (Figure 3-10).
2. Remove cover (27).
3. See (Figure 3-10). Connect the heater power leads, the thermocouple leads, and the oxygen signal leads of the interconnecting cable to the terminal block. The cable leads are tagged for polarity. To avoid a shock hazard, the heater power terminal cover must be installed.
4. Install covers (27, Figure 9-3 and Figure 9-4).

## PNEUMATIC INSTALLATION

### OXYMITTER 4000

#### Reference Air Package

After the Oxymitter 4000 is installed, connect the reference air set to the Oxymitter 4000. Refer to Figure 3-11.

Instrument Air (Reference Air): 10 psig (68.95 kPag) minimum, 225 psig (1551.38 kPag) maximum at 1 l/min (2 scfh) maximum; less than 40 parts per million total hydrocarbons. Regulator outlet pressure should be set at 5 psi (35 kPa). Reference air can be supplied by the reference air set of the IMPS 4000 or SPS 4001B.

If using an IMPS 4000, refer to the IMPS 4000 Intelligent Multiprobe Test Gas Sequencer Instruction Manual for the proper reference air connections.

If using an SPS 4001B, refer to the SPS 4001B Single Probe Autocalibration Sequencer Instruction Manual for the proper reference air connections.

### CAUTION

Do not use 100% nitrogen as a low gas (zero gas). It is suggested that gas for the low (zero) be between 0.4% and 2.0% O<sub>2</sub>. Do not use gases with hydrocarbon concentrations of more than 40 parts per million. Failure to use proper gases will result in erroneous readings.

#### Calibration Gas

Two calibration gas concentrations are used with the Oxymitter 4000, Low Gas - 0.4% O<sub>2</sub> and High Gas - 8% O<sub>2</sub>. See Figure 3-12 for the Oxymitter 4000 connections.

# Instruction Manual

IM-106-340, Rev. 4.2

July 2008

# Oxymitter 4000

Figure 3-11. Air Set, Plant Air Connection

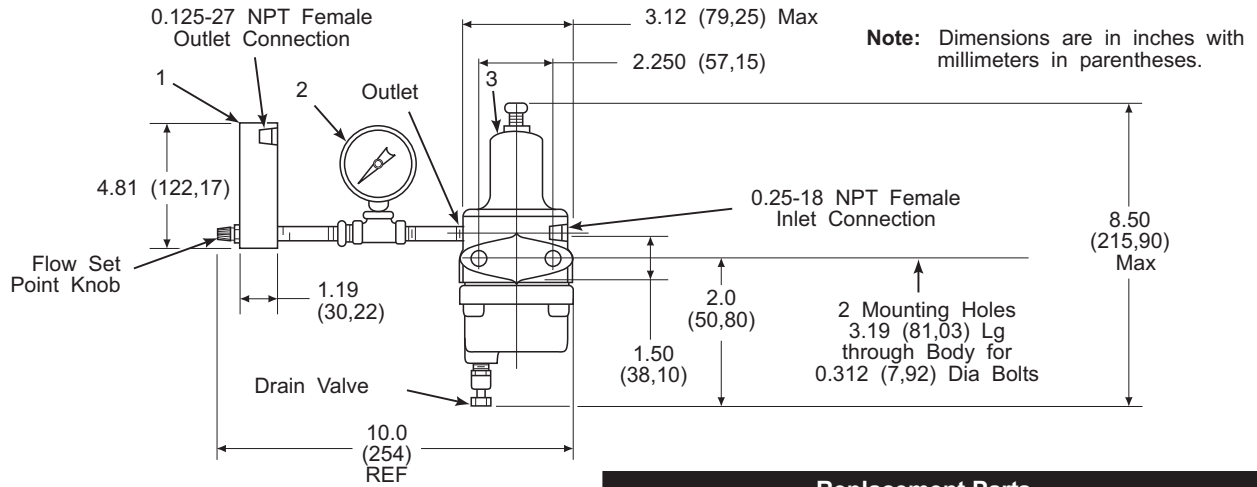

Replacement Parts			
1	Flowmeter	0.2-2.0 scfh	771B635H02
2	2" Pressure Gage	0-15 psig	275431-006
3	Combination Filter-Reg.	0-30 psig	4505C21G01

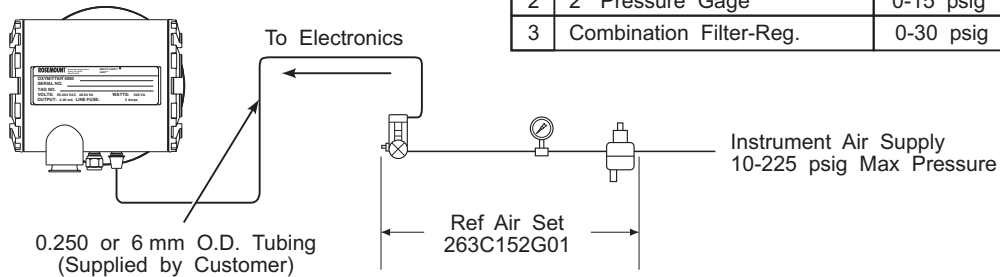

Schematic Hookup for Reference Air Supply on Oxymitter 4000 Probe Head.

38890076

Figure 3-12. Oxymitter 4000 Gas Connections Calibration Gas Connections

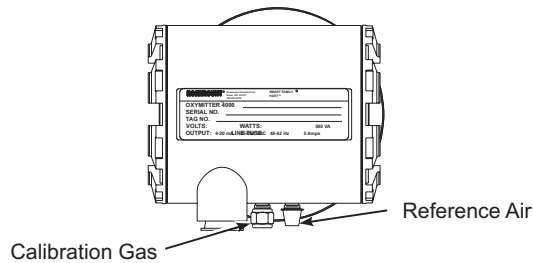

38890077

# Oxymitter 4000

---

## **IMPS 4000 CONNECTIONS**

See the IMPS 4000 Intelligent Multiprobe Sequencer Instruction Manual for wiring and pneumatic connection.

## **SPS 4001B CONNECTIONS**

See the SPS 4001B Single Probe Autocalibration Sequencer Instruction Manual for wiring and pneumatic connection.

---

### **NOTE:**

Upon completing installation, make sure that the Oxymitter 4000 is turned on and operating prior to firing up the combustion process. Damage can result from having a cold Oxymitter 4000 exposed to the process gases.

During outages, and if possible, leave all Oxymitter 4000 units running to prevent condensation and premature aging from thermal cycling.

---

### **⚠ CAUTION**

If the ducts will be washed down during outage, MAKE SURE to power down the Oxymitter 4000 units and remove them from the wash areas.

---

## Section 4 Configuration of Oxymitter 4000 with LOI

---

Verify installation .....	page 4-1
Logic I/O .....	page 4-4

---

### VERIFY INSTALLATION

**⚠ WARNING**

Install all protective equipment covers and safety ground leads before equipment startup. Failure to install covers and ground leads could result in serious injury or death.

### Mechanical Installation

#### Terminal Block Wiring

Ensure the Oxymitter 4000 is installed correctly. See Section 3: Installation.

1. Remove cover (27) to expose terminal block (25).
2. Check the terminal block wiring, Figure 4-1. Be sure the power, 4-20 mA signal, and logic outputs are properly connected and secure.
3. Install housing cover (27, Figure 9-3 or Figure 9-4) on terminal block (25).

Figure 4-1. Electronics Housing  
Terminals with LOI

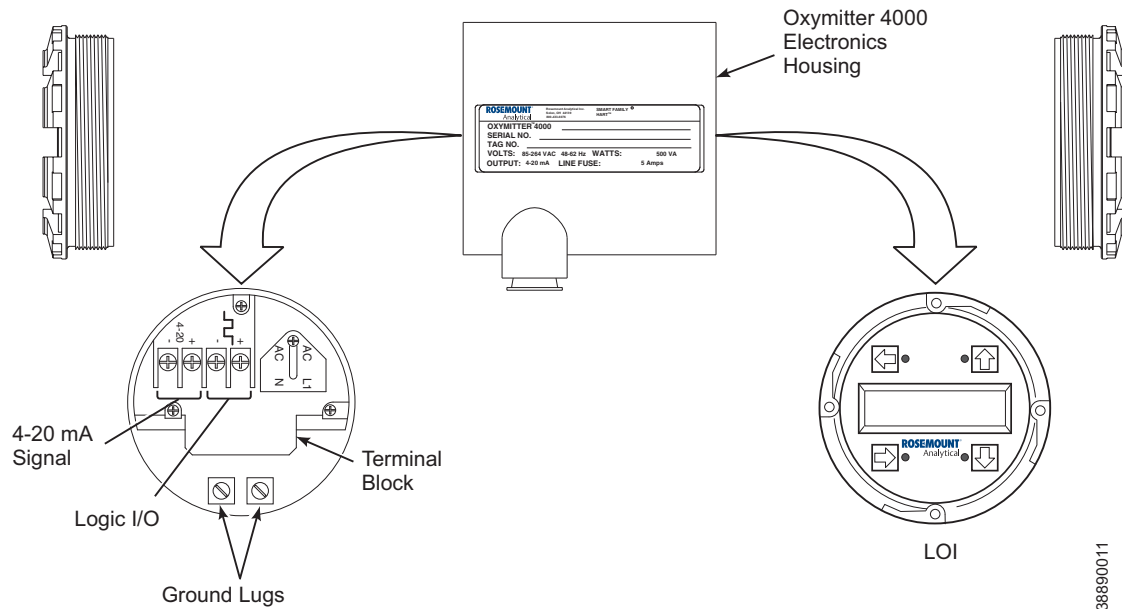

## Oxymitter 4000 Configuration

Located on the microprocessor board are two switches that configure outputs (Figure 4-2). To access these switches, the LOI module must be removed. SW1 determines if the 4-20 mA signal is internally or externally powered. SW2 determines:

1. Range control, HART or LOCAL.
2. Oxygen range, 0 to 10% O<sub>2</sub> or 0 to 25% O<sub>2</sub>. (0 to 40% O<sub>2</sub> is also configurable only through HART/AMS.)
3. The 4-20 mA signal, at fault or power up, 3.5 mA or 21.6 mA.

### **CAUTION**

Remove power before changing defaults. If defaults are changed under power, damage to the electronics package may occur.

### SW1 Setting

The two settings are internally or externally powering the 4-20 mA signal. The factory setting is for the 4-20 mA signal to be internally powered.



**SW2 Setting**

The factory sets this switch as follows:

1. Position 1 is HART/LOCAL. This switch setting controls the configuration of the Oxymitter 4000. The defaults cannot be changed via HART/AMS or the LOI unless the switch is in the HART position. Placing SW2, position 1 in the LOCAL position forces the O<sub>2</sub> range to the setting of position 2. The position 1 switch must be in the LOCAL position or changes in SW2, position 2 will have no effect.
2. Position 2 determines the O<sub>2</sub> range. This can be set to either 0 to 10% O<sub>2</sub> or 0 to 25% O<sub>2</sub>. The factory setting is 0 to 10% O<sub>2</sub>. If necessary, the O<sub>2</sub> range can be configured from 0 to 40% O<sub>2</sub>. To select values within this range, set SW2, position 1 to HART and then enter the range via HART/AMS or the LOI. Do not change SW2, position 1 to LOCAL unless you want to operate in the range specified by SW2, position 2.

**⚠ WARNING**

Typically, the probe's sensing cell, in direct contact with the process gases, is heated to approximately 1357°F (736°C). The external temperature of the probe body may exceed 842°F (450°C). If operating conditions also contain high oxygen levels and combustible gases, the Oxymitter 4000 may self-ignite.

3. Position 3 determines the output at startup or at an alarm. The settings are 3.5 mA or 21.6 mA. The factory setting is 3.5 mA. At startup, the current at the analog output is 3.5 mA or 21.6 mA.
4. Position 4 can be used to set the heater for 115 or 220 VAC operation. This switch is functional only when the software is set for manual voltage selection (Auto Tune = No). Otherwise, the internal electronics auto detect the input line voltage and sets the heater voltage accordingly (Auto Tune = Yes).

**Read O<sub>2</sub> Concentration**

Once the cell is up to operating temperature, the O<sub>2</sub> percentage can be read:

1. To access TP5 and TP6 under the LOI module (Figure 4-2), power down the Oxymitter 4000 and remove the LOI module. Attach alligator leads from a multimeter across TP5 and TP6. Install the LOI module and power up the Oxymitter 4000. Allow time for the cell to reach operating temperature. The calibration and process gases can now be monitored. When a calibration has been initiated, the value at TP5 and TP6 is the % O<sub>2</sub> seen by the cell. Oxygen levels, as seen on the multimeter, are:

$$8.0\% \text{ O}_2 = 8.0 \text{ VDC}$$

$$0.4\% \text{ O}_2 = 0.4 \text{ VDC}$$

2. HART/AMS.
3. Model 751. The loop-driven LCD display.

Figure 4-2. Defaults - Oxymitter 4000 with LOI

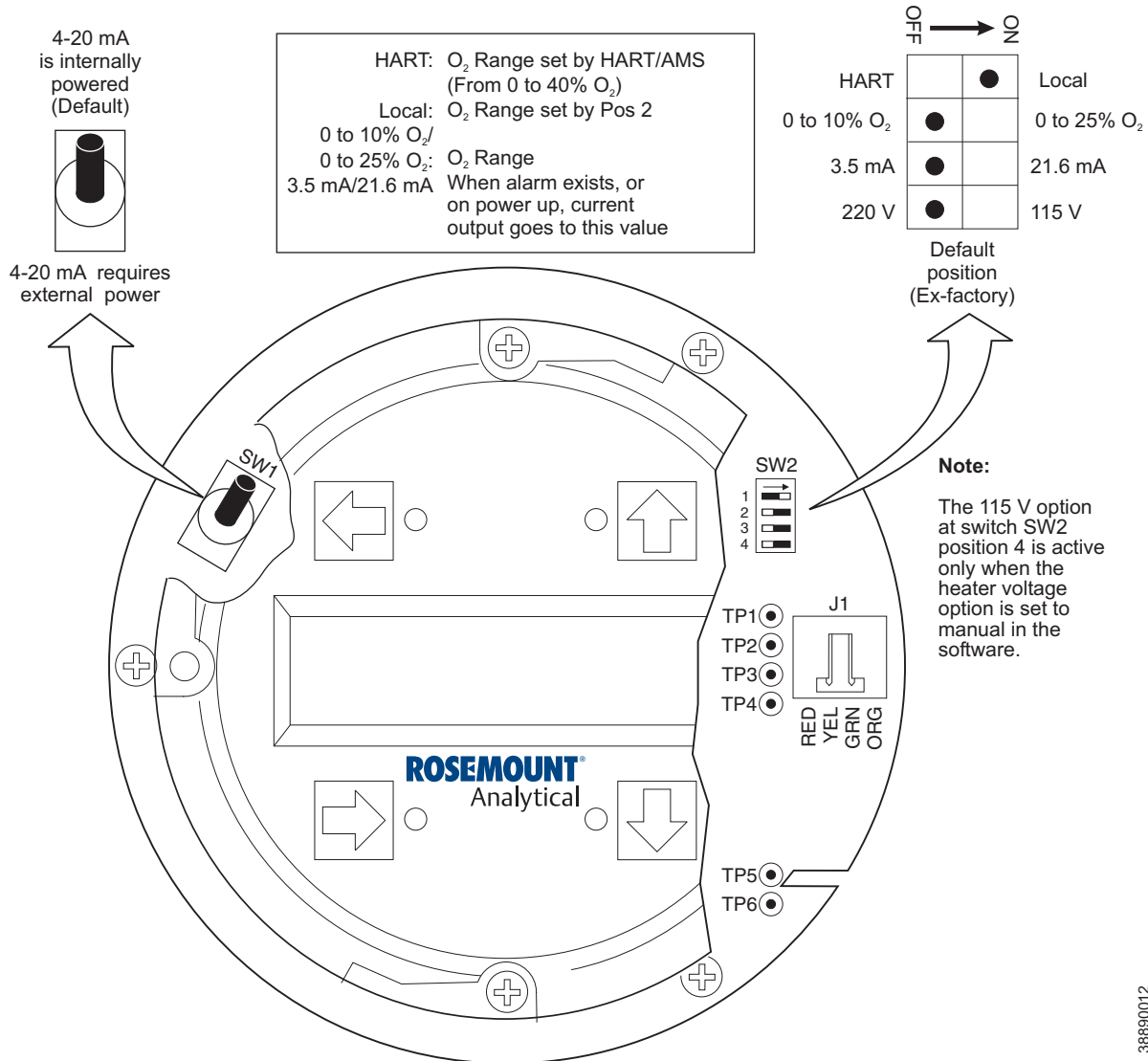

## LOGIC I/O

This two-terminal logic contact can be configured either as a solid-state relay-activated alarm or as a bi-directional calibration handshake signal to an IMPS 4000 or SPS 4001B. The configuration of this signal depends on the setting of the LOGIC I/O PIN MODE via HART/AMS or LOI. The ten different modes available are explained in Table 4-1.

### Alarm

When configured as an alarm, this signal alerts you to an out-of-spec condition. The output is +5 Vdc in series with a 340 ohm resistor.

For optimum performance, Emerson Process Management recommends connecting the output to a Potter & Brumfield 3.2 mA DC relay (P/N R10S-E1Y1-J1.0K).

Of the ten modes in Table 4-1, mode 1 through mode 7 are the alarm modes. The factory default is mode 5 for Oxymitter 4000 units without an IMPS 4000 or SPS 4001B. In this mode, the output will signal when a unit alarm or a CALIBRATION RECOMMENDED indication occurs.

**Calibration Handshake Signal**

If using an optional IMPS 4000 or SPS 4001B, the logic I/O must be configured for calibration handshaking. Of the ten modes in Table 4-1, only modes 8 and 9 are configured for calibration handshaking. For an Oxymitter 4000 with an IMPS 4000 or an SPS 4001B, the factory sets the default to mode 8. In this mode, the logic I/O will be used to communicate between the Oxymitter 4000 and the sequencer and to signal the sequencer when a CALIBRATION RECOMMENDED indication occurs.

Table 4-1. Logic I/O Configuration (as set at HART/AMS or LOI)

Mode	Configuration
0	The unit is not configured for any alarm condition.
1	The unit is configured for a Unit Alarm.
2	The unit is configured for Low O <sub>2</sub> .
3	The unit is configured for both a Unit Alarm and Low O <sub>2</sub> .
4	The unit is configured for a High AC Impedance/CALIBRATION RECOMMENDED.
5*	The unit is configured for both a Unit Alarm and a High AC Impedance/CALIBRATION RECOMMENDED.
6	The unit is configured for both a Low O <sub>2</sub> and High AC Impedance/CALIBRATION RECOMMENDED.
7	The unit is configured for a Unit Alarm, a Low O <sub>2</sub> , and a High AC Impedance/CALIBRATION RECOMMENDED.
8**	The unit is configured for a calibration handshake with IMPS 4000 or SPS 4001B. CALIBRATION RECOMMENDED will initiate the calibration cycle.
9	The unit is configured for a calibration handshake. CALIBRATION RECOMMENDED will not initiate the calibration cycle with the IMPS 4000 or SPS 4001B.

\*The default condition for an Oxymitter 4000 without an IMPS 4000 or SPS 4001B.  
\*\*The default condition for an Oxymitter 4000 with an IMPS 4000 or SPS 4001B.

### Recommended Configuration

#### Recommended Configuration

##### 4-20 mA Signal

The 4-20 mA signal is linear, and can be ranged by the user for O<sub>2</sub> range from 0-40% O<sub>2</sub>. It should be noted that the 4-20 mA signal will go to one of several default values under certain conditions:

Condition	Default	Option
In calibration	4-20 mA signal responds normally to cal gas	4-20 mA signal holds last value during cal. (recommended only if several O <sub>2</sub> probes are being averaged together)
O <sub>2</sub> over preset range	4-20 mA signal defaults to 20.5 mA	none
Critical alarm	4-20 mA signal defaults to 3.5 mA	4-20 mA signal defaults to 21.1 mA
Dead Instrument	4-20 mA signal goes to zero mA	none

It is very important that the control system be configured to recognize these various signal levels, and operators be briefed as to their meaning.

#### Calibration

Emerson Process Management recommends utilizing an autocalibration system, actuated by the "calibration recommended" diagnostic. New O<sub>2</sub> cells may operate for more than a year, but older cells may require recalibration every few weeks as they near the end of their life. This strategy ensures that the O<sub>2</sub> reading is always accurate, and eliminates many unnecessary calibrations based on calendar days or weeks since previous calibration. When utilizing the SPS 4001B or IMPS 4000, consider wiring some or all associated alarm contacts.

1. CALIBRATION INITIATE. Contact from the control room to an SPS 4001B or IMPS 4000 (one per probe) provides the ability to manually initiate a calibration at any time from the control room. Note that calibrations can also be initiated from a HART handheld communicator, from Asset Management Solutions software, or from the keypad on the Oxymitter 4000.
2. IN CALIBRATION. One contact per probe provides notification to the control room that the "calibration recommended" diagnostic has initiated an automatic calibration through the SPS 4001B or IMPS 4000. If the O<sub>2</sub> signal is being utilized in an automatic control loop, this contact should be utilized to place the control loop into manual during calibration.
3. CALIBRATION FAILED. One contact per probe from an SPS 4001B or IMPS 4000 to the control room for notification that the calibration procedure failed. Grouped with this alarm is an output from a pressure switch which indicates when the calibration gas bottles are empty.
4. 4-20 mA SIGNAL DURING CALIBRATION. The 4-20 mA signal can be configured to respond normally during any calibration, or it can be configured to hold the last O<sub>2</sub> value upon the initiation of calibration. The factory default is for the 4-20 mA signal to track (operate normally) throughout calibration. Holding the last O<sub>2</sub> value may be useful if several probes are being averaged for the purpose of automatic control. Unless several probes are being averaged, always place control loops that are using the O<sub>2</sub> signal into the manual mode prior to starting the calibration.

# Section 5 Startup and Operation of Oxymitter 4000 with Membrane Keypad

Power Up ..... page 5-1  
 Operation ..... page 5-2

## POWER UP

### Startup Display

When power is applied to the probe, the cell heater turns on. It takes approximately one half hour for the cell to heat to operating temperature. This condition is indicated by the top four LEDs (DIAGNOSTIC ALARMS) on the membrane keypad (Figure 5-1). Starting with the CALIBRATION LED, the LEDs light in ascending order until all four LEDs are on. At this point, all four turn off and the cycle starts again. This ramp cycle continues until the cell is up to operating temperature.

### Operating Display

The ramp cycle turns into a cycle where the diagnostic LEDs light in sequence from the top to the bottom, one at a time. After the bottom LED turns on, the sequence starts again at the top with the HEATER T/C LED (Figure 5-1).

Figure 5-1. Startup and Normal Operation

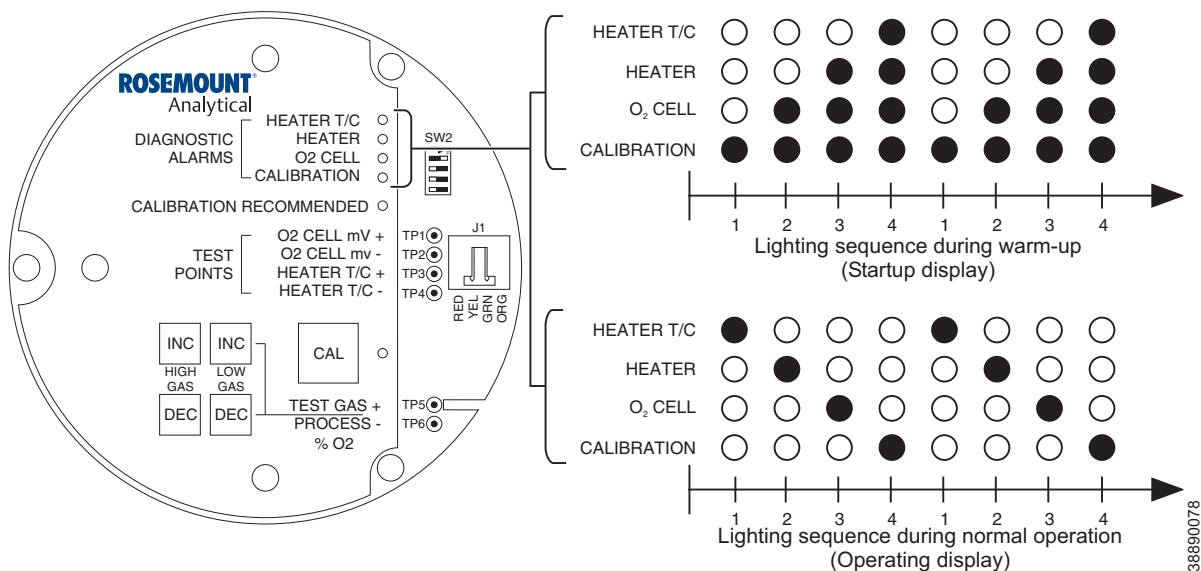

**Error**

If there is an error condition at startup, one of the diagnostics LEDs will be blinking. Refer to Section 8: Troubleshooting, to determine the cause of the error. Clear the error, cycle power, and the operating display should return.

**Keypad**

The five membrane keys on the membrane keypad are only used during calibration to adjust the high and low gas and to initiate the calibration sequence (Figure 5-2).

**Reference Air**

Ensure reference air, if used, is set to 1 l/min (2 scfh)

**OPERATION****Overview**

Ensure the Oxymitter 4000 is at normal operation. The diagnostic LEDs will display the operating cycle. All other LEDs should be off (Figure 5-1).

**DIAGNOSTIC ALARM LEDs**

If there is an error in the system, one of these LEDs will flash various blink codes (Section 8: Troubleshooting). In the case of multiple errors, only one will be displayed based on a priority system. Correct the problem and cycle power. The operating display will return or the next error will be displayed. The alarms are:

HEATER T/C  
HEATER  
O<sub>2</sub> CELL  
CALIBRATION

**CALIBRATION RECOMMENDED LED**

Turns on when the system determines that a calibration is recommended. Further information is available in Section 9: Maintenance and Service.

**TEST POINTS**

Test points 1 through 6 will allow you to monitor with a multimeter: the heater thermocouple, O<sub>2</sub> cell millivolt, and the process O<sub>2</sub>.

1. TP1 and TP2 monitor the oxygen cell millivolt output which equates to the percentage of oxygen present.
2. TP3 and TP4 monitor the heater thermocouple.
3. TP5 and TP6 monitor the process gas or the calibration gas parameter.

**CAL LED**

The CAL LED is on steady or flashing during calibration. Further information is available in Section 9: Maintenance and Service.

Figure 5-2. Calibration Keys

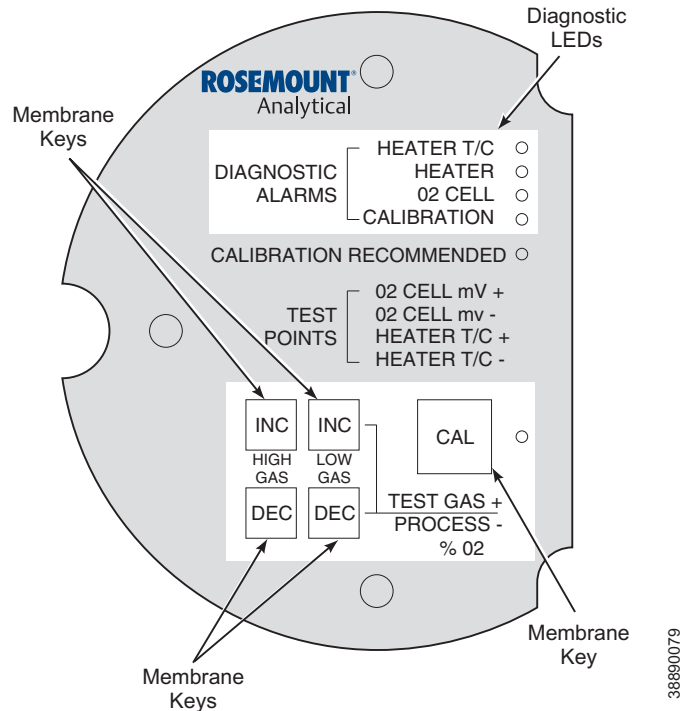

**Keys**

INC and DEC. The INC and DEC keys are used to set the values of the calibration gases. Attach a multimeter across TP5 and TP6. The calibration and process gases can now be monitored. Pressing the INC or DEC once will cause the output to switch from the process gas to the calibration gas. Pressing INC or DEC a second time will increase or decrease the calibration gas parameter. If the keys have been inactive for one minute, the output reverts to the process gas. When a calibration has been initiated, the value at TP5 and TP6 is the % O<sub>2</sub> seen by the cell.

Oxygen levels, as seen on the multimeter, are:

- 8.0% O<sub>2</sub> = 8.0 volts DC
- 0.4% O<sub>2</sub> = 0.4 volts DC

**CAL**

The CAL key can:

- Initiate a calibration.
- Sequence through calibration.
- Abort the calibration.

**NOTE**

Refer Section 9: Maintenance and Service, for calibration instructions.

**Model 751 Remote Powered Loop LCD Display (Optional)**

Refer to Remote Powered Loop LCD manual for calibration and operation.

# Oxymitter 4000

---

**Instruction Manual**

IM-106-340, Rev. 4.2

July 2008



---

## Section 6      Startup and Operation of Oxymitter 4000 with LOI

---

---

Power Up .....	page 6-1
Start Up Oxymitter 4000 Calibration .....	page 6-3
Navigating the Local Operator Interface .....	page 6-3
LOI Key Designations .....	page 6-4
LOI Menu Tree .....	page 6-4
Oxymitter 4000 Setup at the LOI .....	page 6-6
LOI Installation .....	page 6-9
Oxymitter 4000 Test Points .....	page 6-10
Remote Powered Loop LCD Display (Optional) .....	page 6-10

---

### POWER UP

#### Startup Display

When power is applied to the probe, the cell heater turns on. It takes approximately one half hour for the cell to heat to operating temperature. This condition is indicated by a "warm up" display on the LOI (Figure 6-1). This message will continue to display until the cell is up to operating temperature.

#### Operating Display

The normal operating display is the % O<sub>2</sub> concentration. The "normal" display is shown in Figure 6-2.

#### Error

If there is an error condition at startup, an alarm message will be displayed. Refer to Section 8: Troubleshooting, to determine the cause of the error. Clear the error, cycle power, and the % O<sub>2</sub> display should return.

#### LOI

The Local Operator Interface can be used to change the software and alarm settings, to adjust the high and low gas settings, and to initiate the calibration sequence. Refer to the LOI menu (Figure 6-4).

Figure 6-1. Startup Display

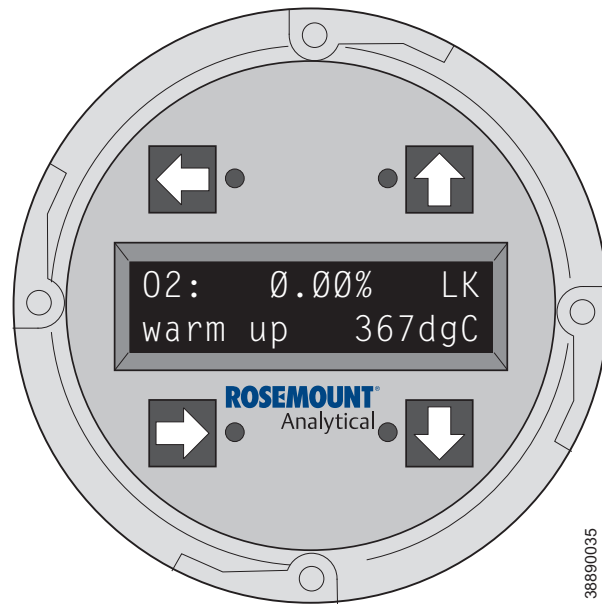

Figure 6-2. O<sub>2</sub> Concentration Display

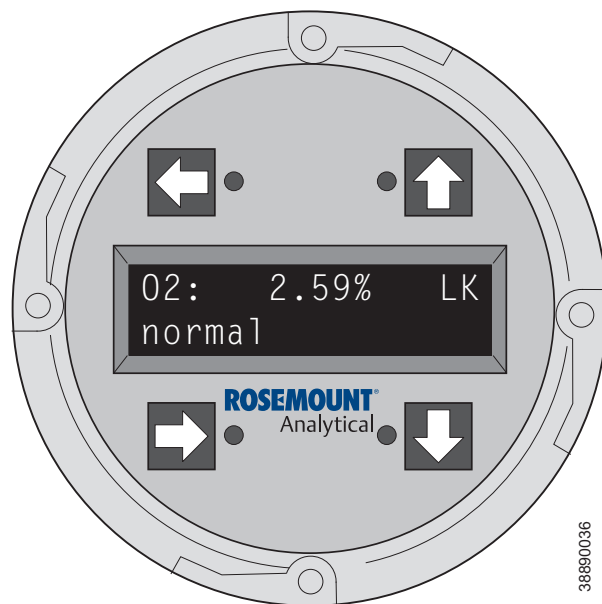
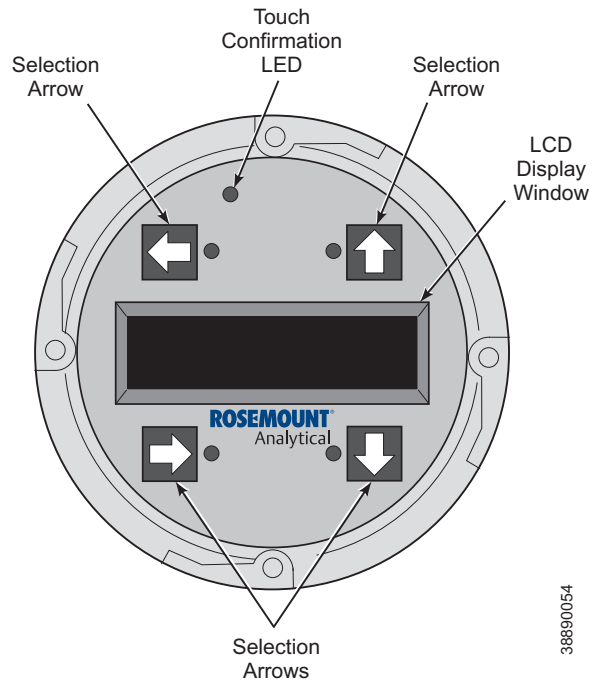

Figure 6-3. LOI Features



**START UP OXYMITTER 4000 CALIBRATION**

Refer to Section 9: Maintenance and Service, for calibration instructions.

**NAVIGATING THE LOCAL OPERATOR INTERFACE**

**Overview**

The Local Operator Interface (LOI), shown in Figure 6-3, utilizes a bright blue gas-fluorescent display. Intensity is adjustable. There is an Infrared LED source and a detector for each key. The detectors can detect a finger placed above the button through the glass window. There is no need to open the instrument in bad weather in order to access the electronics.

It should be noted that the Oxymitter 4000 also utilizes HART communications, permitting access to all instrument functionality anywhere the 4-20 mA signal terminates via a HART model 275/375 handheld communicator.

**Lockout**

The Local Operator Interface (LOI) has a lockout feature that prevents nuisance actuation by someone brushing against the glass window, raindrops, dirt, insects, etc. This lockout mode is automatically established when no buttons are pushed for 30 seconds (default). This countdown to lockout is configurable.

In order to unlock the display, input a "Z" pattern. First, push the top left (gray) arrow, then the top right, followed by the bottom left and finally the bottom right. The "LK" notation in the upper right corner of the display will now disappear. Push the gray arrow at the top left hand corner once more to enter into the menu structure. Once one moves deeper into the menu structure, additional time is provided to the user so that the lockout initiation does not become a nuisance. This additional "revert" time is defaulted at one hour and is also user configurable.

---

**NOTE**

Always clean dust and soil away from the LOI screen each time the LOI is used. Excessive dust can prevent the LOI from entering lockout. This condition can cause uncommanded operations to occur.

---

## **LOI KEY DESIGNATIONS**

The gray key (top left) will move one level higher in the menu structure. When entering numbers, this key will move the cursor to the left. This key also doubles as an "Enter" key, once numbers are entered, and when the cursor is moved to it's left-most position. The new data entry value will appear in the top line of the LOI display once it is accepted.

The blue key (bottom left) acts as a selector when choosing from among a number of menu items. This key also will move the cursor to the right when entering numbers.

Up/Down keys (to the left side of the keypad) are used to increment up and down when selecting from a series of menu picks. They are also used for incrementing values up and down for data input.

## **LOI MENU TREE**

This LOI menu for the Oxymitter 4000 is shown in Figure 6-4. This menu tree is specific to the Oxymitter 4000. The menu tree will assist in navigating the LOI.

Menu items in normal text display information, only. Menu Items in italics permit data entry. Menu items in bold text are procedures.

Figure 6-4. Menu Tree for Local Operator Interface on the Oxymitter 4000 (Sheet 1 of 2)

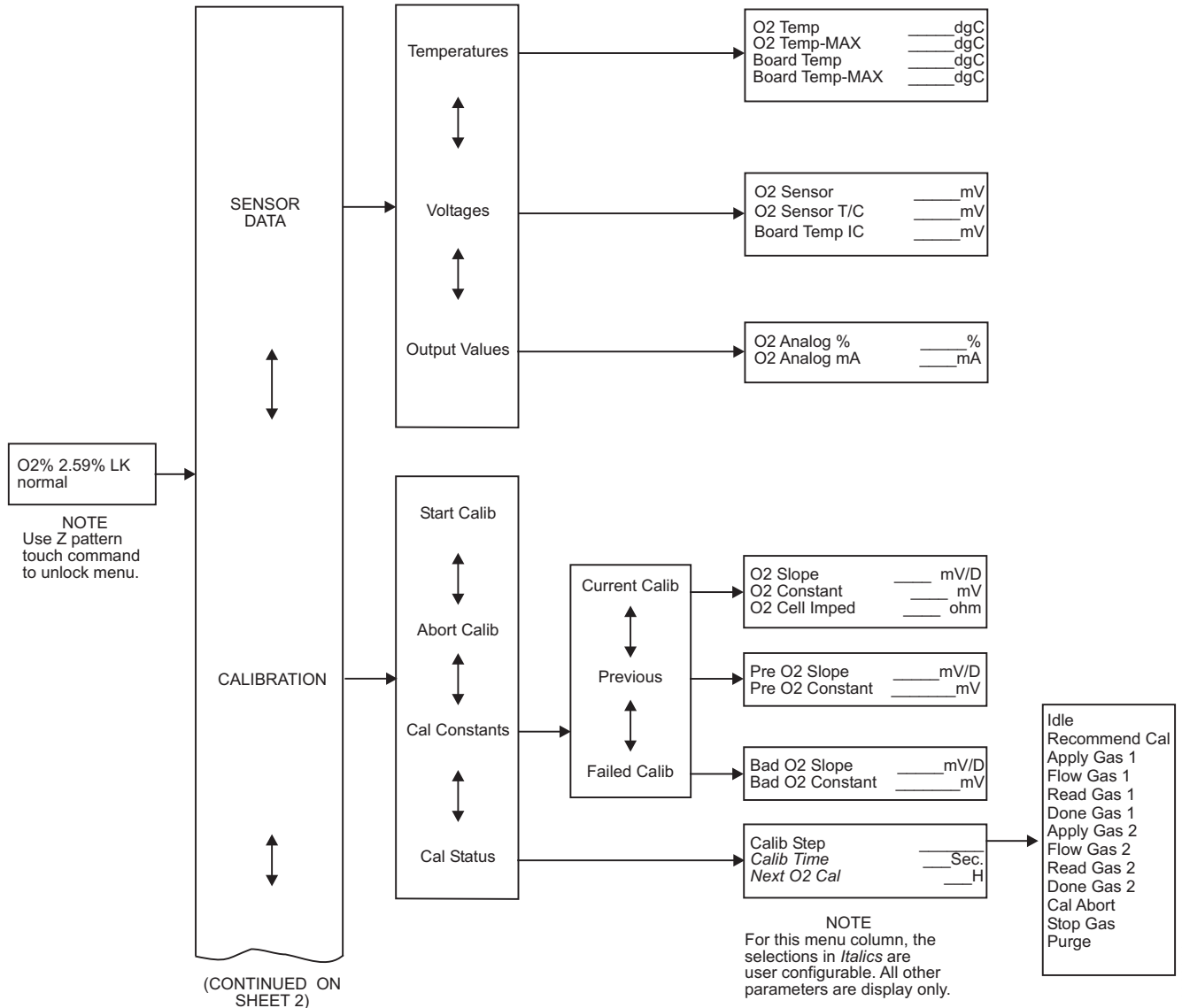
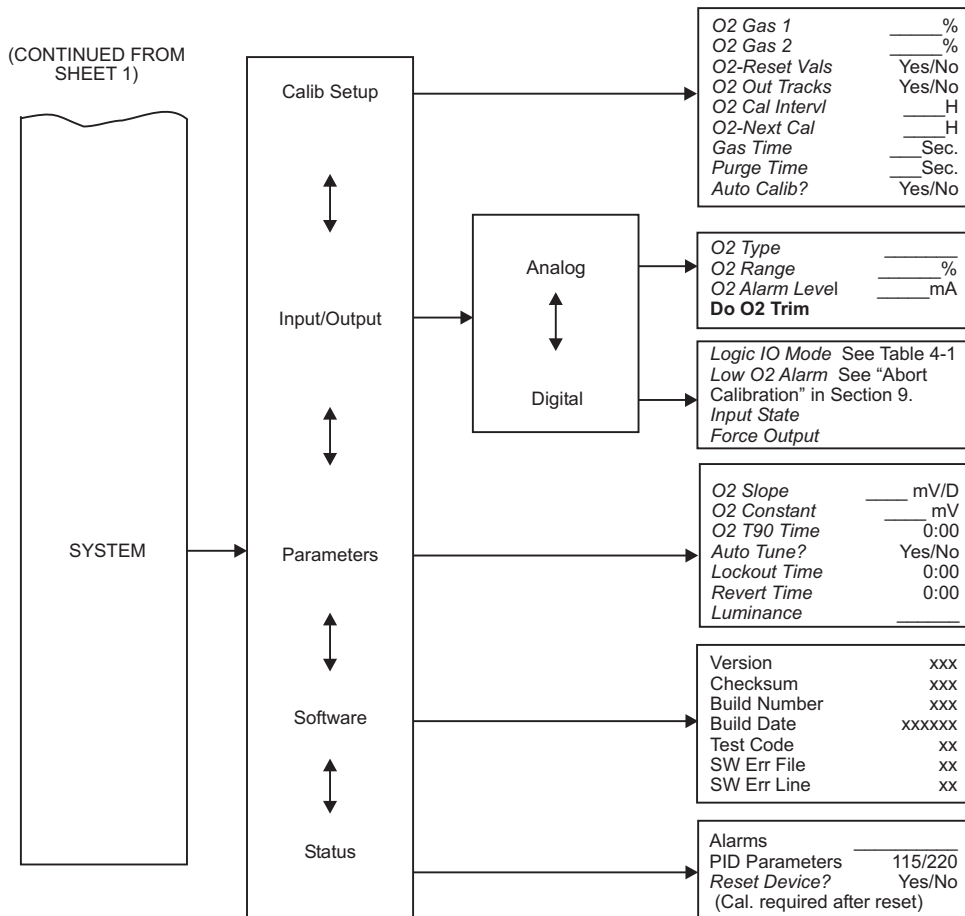

Figure 6-4. Menu Tree for Local Operator Interface (LOI) on the Oxymitter 4000 (Sheet 2 of 2)



NOTE  
In column four of this menu, the selections in *Italics* are user configurable. **Bold** text selections are procedures; related instructions are displayed on the LOI. All other parameters are display only.

38890018

## OXYMITTER 4000 SETUP AT THE LOI

In setting up the Oxymitter 4000 from the LOI, it is best to start at the SYSTEM/Calibration Setup menu, Figure 6-4.

### SYSTEM/Calibration Setup

**O2 Gas #1** - Enter the high or low cal gas value (the order is not important).

**O2 Gas #2** - Enter the second cal gas value.

### NOTE

Refer to Section 9: Maintenance and Service, for calibration instructions.

**NOTE**

Emerson Process Management recommends 0.4% O<sub>2</sub> and 8% O<sub>2</sub> for calibration gases.

---

**O2 Reset Values** - Resets factory default values.

**O2 Output Tracks** - 4 to 20 mA signal can be held at the last value during calibration, or the signal can be left to track the cal gases.

**O2 Cal Interval** - If automatic calibration is selected, this selects the interval between calibrations.

**O2 Next Cal** - If automatic calibration is selected, this selects the time until the first initial calibration takes place.

**Gas Time** - How long should each cal gas flow. Factory default is 300 seconds, but the user may want to vary this depending upon the length of calibration gas tubing runs.

**Purge Time** - Used if the O<sub>2</sub> output is selected to hold the last value during calibration. After the second cal gas is removed, how long until the sensor comes back to the normal process reading, and the 4-20 mA signal can be released.

**Auto Calib?** - Select "Yes" if an SPS or IMPS autocalibration system is part of the system.

**SYSTEM/Input/Output**

**Analog**

Pertaining to the analog 4-20 mA signal representing O<sub>2</sub>.

**O2 Type** - 4-20 mA signal may be configured to increase with increasing O<sub>2</sub> or the reverse.

**O2 Range** - Upper O<sub>2</sub> range is user selectable.

**O2 Alarm Level** - User can configure the digital output to alarm at a given O<sub>2</sub> level.

**Do O2 Trim** - Procedure for calibrating the 4-20 mA signal to a precision mA source. Procedure is intuitive.

**Digital**

A bi-directional logic signal may be configured as an alarm, or as a calibration handshake signal.

**Logic I/O Mode** - One of 9 different sets of conditions can be set for the digital signal. See Table 8-2.

**Low O2 Alarm** - If any of the conditions noted above include a low O<sub>2</sub> process alarm, set the value here.

**Input State** - Notes the current condition of the bi-directional digital signal.

**Force Output** - Forces the output state of the signal to either open or closed. This is used primarily when diagnosing potential problems with this signal.

### SYSTEM/Parameters

**O<sub>2</sub> Slope** - O<sub>2</sub> slope is data regarding the strength of the sensing cell output. This information is automatically calculated after a calibration, and the user does not normally input this data.

**O<sub>2</sub> Constant** - O<sub>2</sub> constant is the amount of voltage a cell generates with ambient air as the calibration gas. Again, this is normally calculated as a result of calibration, and is not normally input by the user.

**O<sub>2</sub> T90 Time** - Some users may feel that the O<sub>2</sub> reading is too active for certain processes. This feature permits the user to dampen the O<sub>2</sub> signal. The default value is zero seconds dampening.

**Auto Tune** - The electronics detects the line voltage powering the instrument automatically, and picks proper algorithms for heater control. User can force a high voltage algorithm, or a low, but Auto Tune is the default, and is recommended.

**Lockout Time** - Keypad lockout time default is 30 sec., but it is user configurable. A "Z" keypad pattern will unlock the keypad.

**Revert Time** - Once a user goes one level deep into the menu structure, an additional "revert time" is provided to prevent nuisance lockouts. One hour is the default, and it is user configurable.

**Luminance** - Gas fluorescence brightness is user adjustable.

### SYSTEM/Status

**Alarms** - Diagnostic alarms. Section 8: Troubleshooting.

**PID Parameter** - Displays the line voltage, powering the Oxymitter, and infers the temperature control algorithm being used to control heater temperature.

**Reset Device** - Device can be reset here as opposed to re-powering. Calibration parameters will be lost.

### SYSTEM/Software

This is data regarding the Oxymitter 4000 software version, and errors that may have occurred.

### SENSOR DATA

Displays information about the O<sub>2</sub> cell and thermocouple.



**Temperatures**

**O<sub>2</sub> Temp** - Indicates the thermocouple temperature at the sensing cell; this should always be 1357°F (736°C).

**O<sub>2</sub> Temp Max** - Maximum temperature the cell has seen. (Some process temperatures can exceed the 1357°F (736°C) setpoint temperature, and this will *indicate this condition.*)

**Board Temp** - The temperature inside the Oxymitter electronics housing 185°F (85°C), is the max.

**Board Temp Max** - This is the maximum temperature that the electronics has experienced over time.

**Voltages**

The raw mV signals feeding the temperature indications listed in the previous paragraph.

**Output Values**

Indication of the current readings for O<sub>2</sub> and mA.

**LOI INSTALLATION**

The LOI module connects to the top of the electronic assembly in the electronics housing. There are four matching connectors (Figure 6-5) on the back of the LOI module that allow the user to orient (rotate) the LOI as desired.

Figure 6-5. LOI Module Connectors

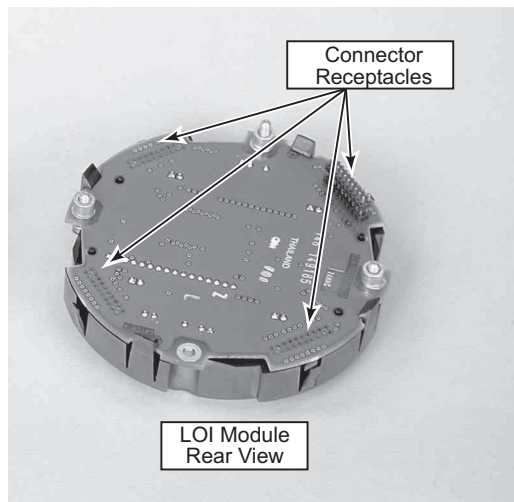

# Oxymitter 4000

## OXYMITTER 4000 TEST POINTS

Refer to Figure 6-6. System test points are located on the board below the LOI module. Test points 1 through 6 allow you to monitor with a multimeter: the heater thermocouple, the O<sub>2</sub> cell millivolt, and the process O<sub>2</sub>.

- TP1 and TP2 monitor the oxygen cell millivolt output which equates to the percentage of oxygen present.
- TP3 and TP4 monitor the heater thermocouple.
- TP5 and TP6 monitor the process gas or the calibration gas parameter.

## REMOTE POWERED LOOP LCD DISPLAY (OPTIONAL)

Refer to Remote Powered Loop LCD manual for calibration and operation.

Figure 6-6. Oxymitter 4000 - Test Points

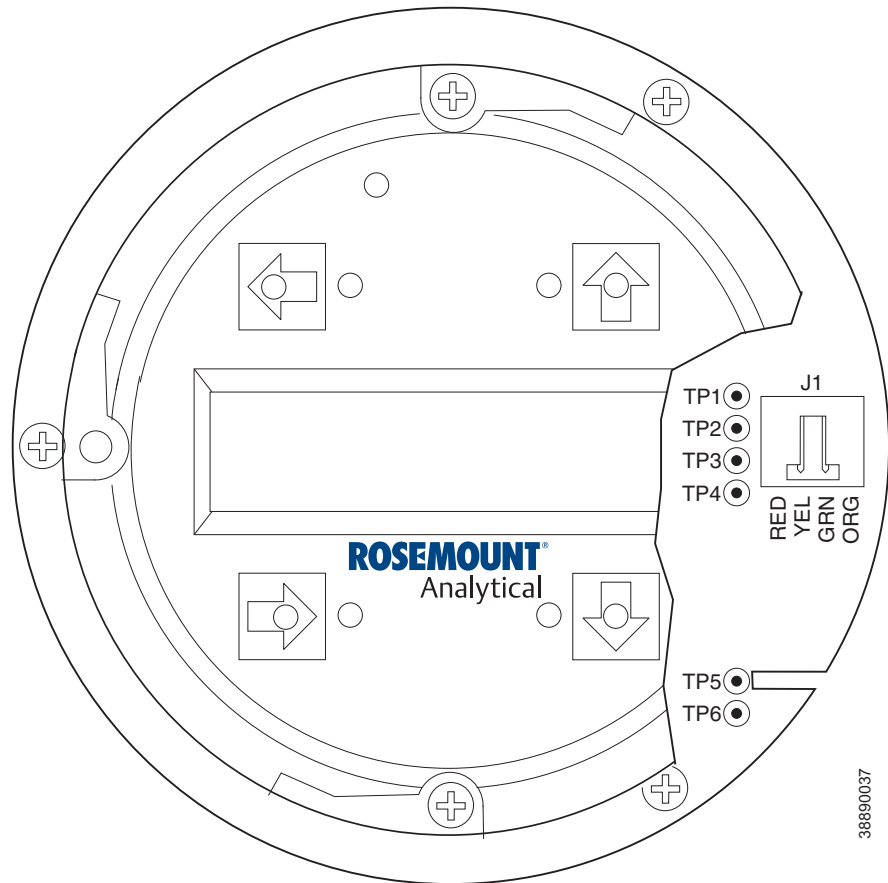

---

## Section 7 HART/AMS

---

Overview .....	page 7-1
HART Communicator Signal Line Connections .....	page 7-2
HART Communicator PC Connections .....	page 7-2
Off-Line and On-Line Operations .....	page 7-4
Logic I/O Configurations .....	page 7-4
HART/AMS Menu Tree .....	page 7-4
HART Communicator O <sub>2</sub> Cal Method .....	page 7-8
Defining a Timed Calibration via HART .....	page 7-9
D/A Trim Procedure .....	page 7-9

---

### OVERVIEW

The HART Communicator is a handheld communications interface device. It provides a common communications link to all microprocessor-based instruments that are HART compatible. The handheld communicator contains an 8 x 21 character liquid crystal display (LCD) and 25 keys. A pocket-sized manual, included with the HART Communicator, details the specific functions of all the keys.

To interface with the Oxymitter 4000, the HART Communicator requires a termination point along the 4-20 mA current loop and a minimum load resistance of 250 ohms between the communicator and the power supply.

The HART Communicator accomplishes its task using a frequency shift keying (FSK) technique. With the use of FSK, high-frequency digital communication signals are superimposed on the Oxymitter 4000's 4-20 mA current loop. The HART communicator does not disturb the 4-20 mA signal, since no net energy is added to the loop.

The HART Communicator may be interfaced with a personal computer (PC), providing that special software has been installed. To connect the HART Communicator to a PC, an interface adapter is required. Refer to the proper HART Communicator documentation in regard to the PC interface option.

## **HART COMMUNICATOR SIGNAL LINE CONNECTIONS**

The HART Communicator can connect to the Oxymitter 4000's analog output signal line at any wiring termination in the 4-20 mA current loop. There are two methods of connecting the HART Communicator to the signal line. For applications in which the signal line has a load resistance of 250 ohms or more, refer to method 1. For applications in which the signal line load resistance is less than 250 ohms, refer to method 2.

### **Method 1, For Load Resistance $\geq$ 250 Ohms**

Refer to Figure 7-1 and the following steps to connect the HART Communicator to a signal line  $<$  250 ohms or more of load resistance.

#### **⚠ WARNING**

Explosions can result in death or serious injury. Do not make connections to the HART Communicator's serial port, 4-20 mV signal line, or NiCad recharger jack in an explosive atmosphere.

Using the supplied lead set, connect the HART Communicator in parallel with to the Oxymitter 4000. Use any wiring termination points in the analog output 4-20 mA signal line.

### **Method 2, For Load Resistance $<$ 250 ohms**

Refer to Figure 7-2 and the following steps to connect the HART Communicator to a signal line with  $<$  250 ohms load resistance.

#### **⚠ WARNING**

Explosions can result in death or serious injury. Do not make connections to the HART Communicator's serial port, 4-20 mA signal line, or NiCad recharger jack in an explosive atmosphere.

1. At a convenient point, break the analog output 4-20 mA signal line and install the optional 250 ohm load resistor.
2. Plug the load resistor into the loop connectors (located on the rear panel of the HART Communicator).

## **HART COMMUNICATOR PC CONNECTIONS**

There is an option to interface the HART Communicator with a personal computer. Load the designated AMS software into the PC. Then link the HART Communicator to the PC using the interface PC adapter that connects to the serial port (on the communicator rear panel).

Refer to the proper HART Communicator documentation in regard to the PC interface option.

Figure 7-1. Signal Line Connections,  $\geq 250 \text{ Ohms}$  Load Resistance

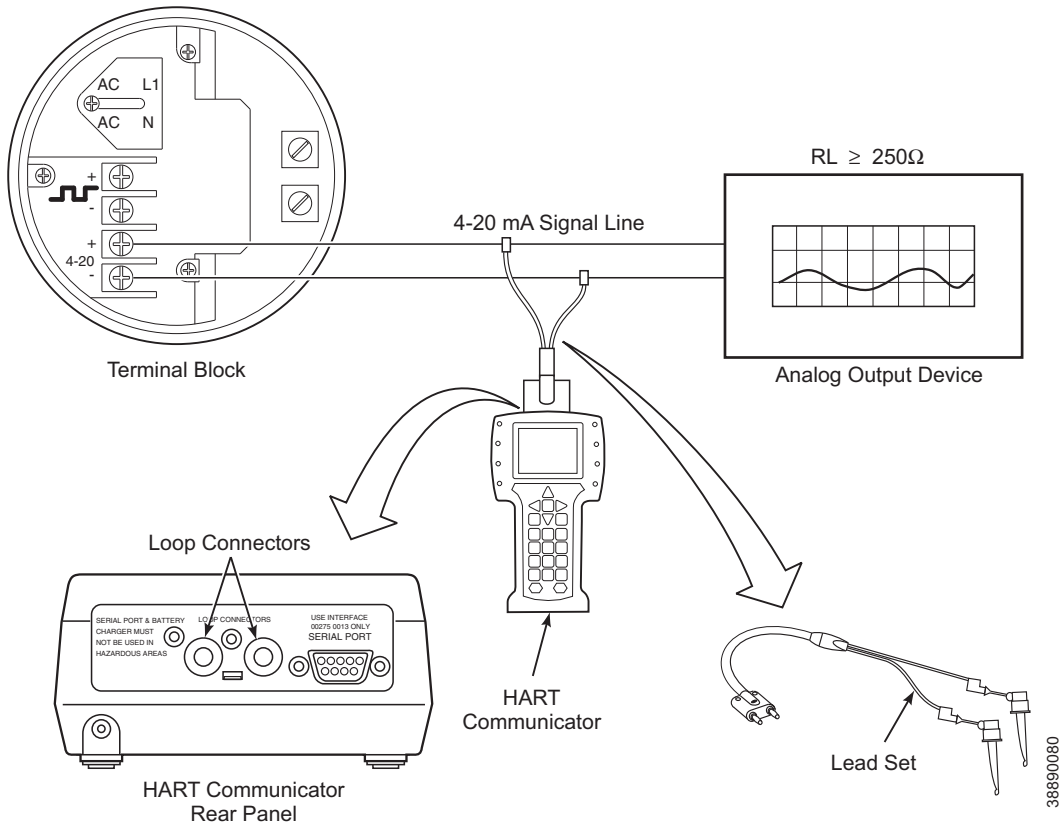
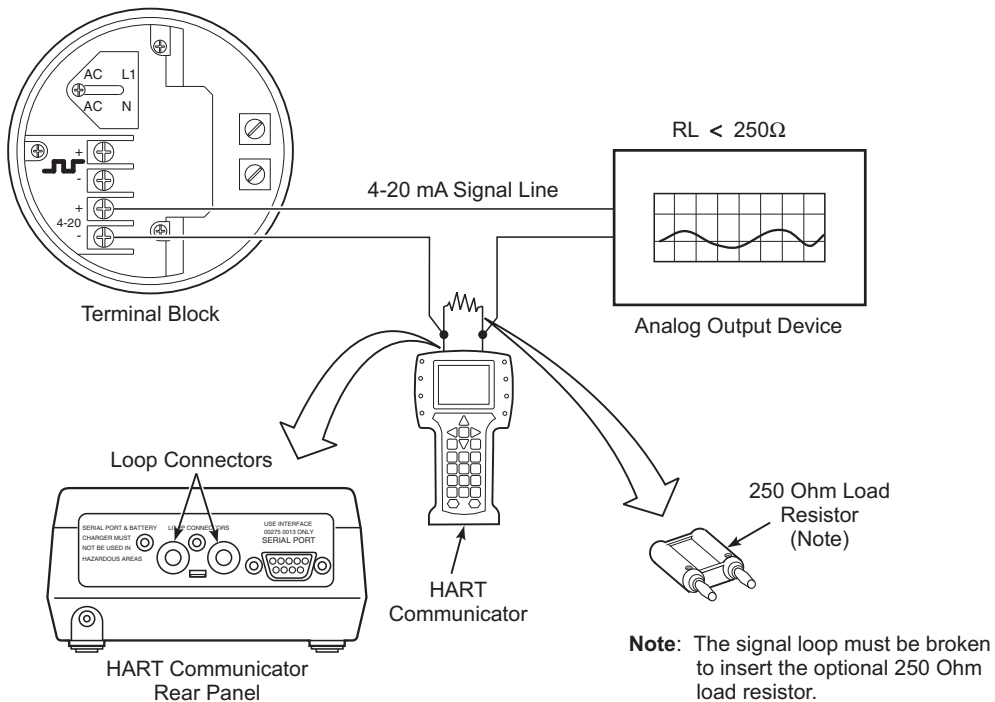

Figure 7-2. Signal Line Connections,  $< 250 \text{ Ohms}$  Load Resistance



# Oxymitter 4000

## OFF-LINE AND ON-LINE OPERATIONS

The HART Communicator can be operated both off-line and on-line.

Off-line operations are those in which the communicator is not connected to the Oxymitter 4000. Off-line operations can include interfacing the HART Communicator with a PC (refer to applicable HART documentation regarding HART/PC applications).

In the on-line mode, the communicator is connected to the 4-20 mA analog output signal line. The communicator is connected in parallel to the Oxymitter 4000 or in parallel to the 250 ohm load resistor.

### NOTE

If the HART Communicator is turned on while connected to the 4-20 mA analog output signal line, an undefined status indication appears while the communicator warms up. Wait until the warm-up period ends to continue.

The opening menu displayed on the LCD is different for on-line and off-line operations. When powering up a disconnected (off-line) communicator, the LCD will display the Main Menu. When powering up a connected (on-line) communicator, the LCD will display the On-line Menu. Refer to the HART Communicator manual for detailed menu information.

## LOGIC I/O CONFIGURATIONS

The Oxymitter 4000 logic I/O output can be configured for ten different modes through HART/AMS. The factory default condition is Mode 5. A list of possible configurations appear in Table 7-1.

The Unit Alarm configuration available for Modes 1, 3, 5, and 7 refers to the diagnostic alarm faults in Table 8-1.

## HART/AMS MENU TREE

This section consists of a menu tree for the HART Communicator. This menu is specific to Oxymitter 4000 applications.

Table 7-1. Logic I/O Configuration (as set at HART/AMS or LOI)

Mode	Configuration
0	The unit is not configured for any alarm condition.
1	The unit is configured for a Unit Alarm.
2	The unit is configured for Low O <sub>2</sub> .
3	The unit is configured for both a Unit Alarm and Low O <sub>2</sub> .
4	The unit is configured for a High AC Impedance/CALIBRATION RECOMMENDED.
5*	The unit is configured for both a Unit Alarm and a High AC Impedance/CALIBRATION RECOMMENDED.
6	The unit is configured for both a Low O <sub>2</sub> and High AC Impedance/CALIBRATION RECOMMENDED.
7	The unit is configured for a Unit Alarm, a Low O <sub>2</sub> , and a High AC Impedance/CALIBRATION RECOMMENDED.
8**	The unit is configured for a calibration handshake with IMPS 4000 or SPS 4001B. CALIBRATION RECOMMENDED will initiate the calibration cycle.
9	The unit is configured for a calibration handshake. CALIBRATION RECOMMENDED will not initiate the calibration cycle with the IMPS 4000 or SPS 4001B.

\*The default condition for an Oxymitter 4000 without an IMPS 4000 or SPS 4001B.

\*\*The default condition for an Oxymitter 4000 with an IMPS 4000 or SPS 4001B.

Figure 7-3. HART/AMS Menu Tree (Sheet 1 of 3)

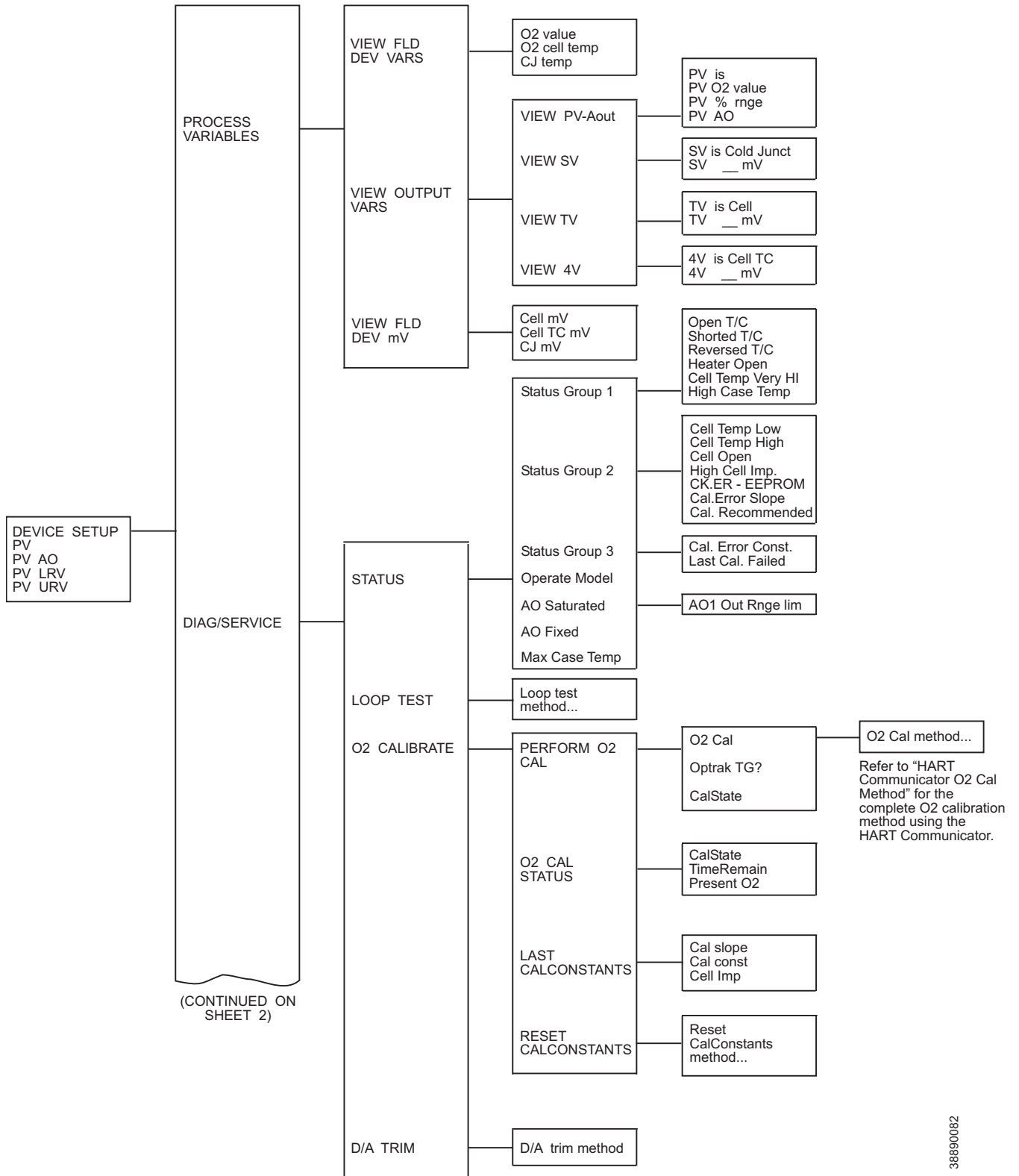

# Oxymitter 4000

Figure 7-3. HART/AMS Menu Tree (Sheet 2 of 3)

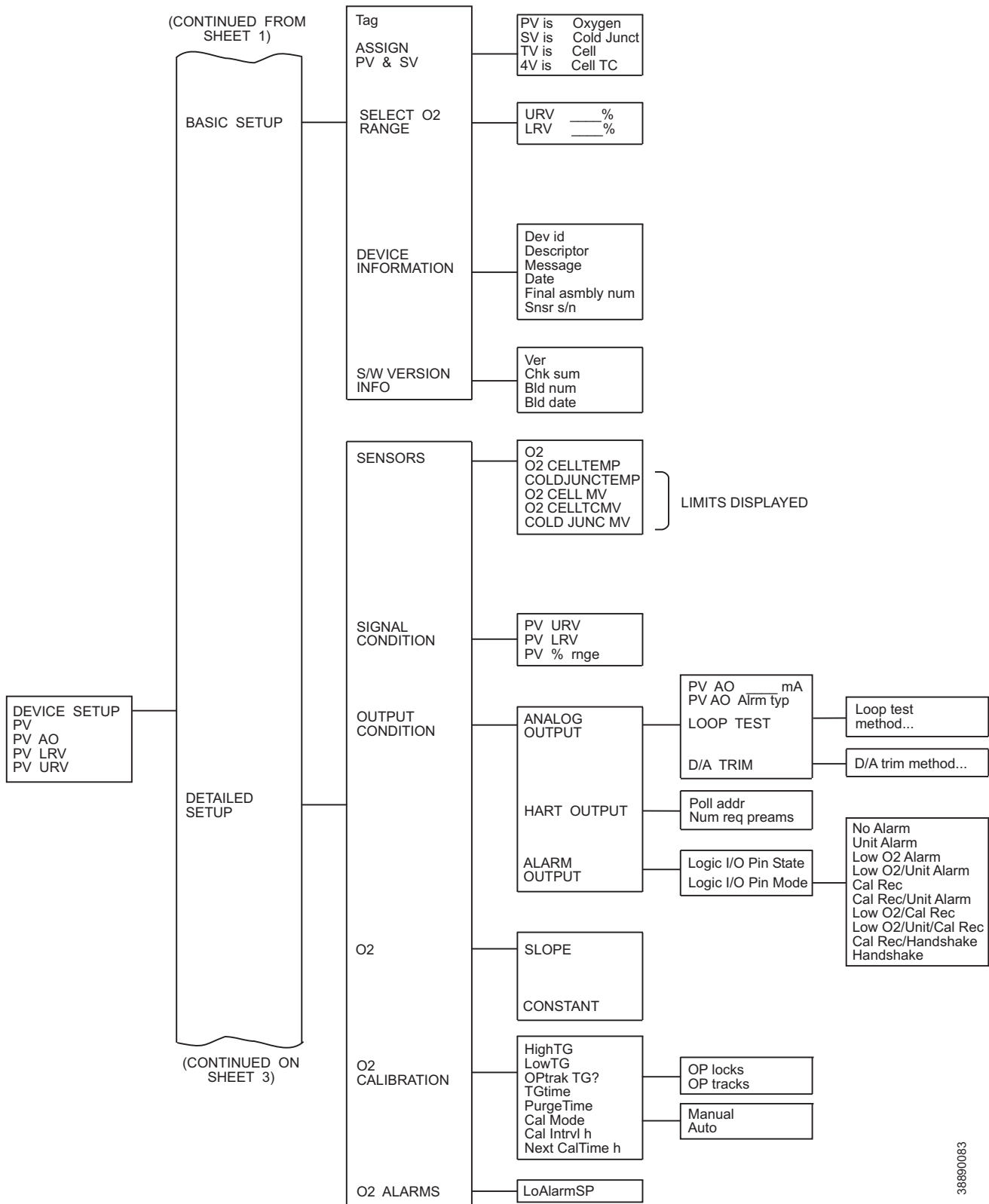

38890083



Figure 7-3. HART/AMS Menu Tree (Sheet 3 of 3)

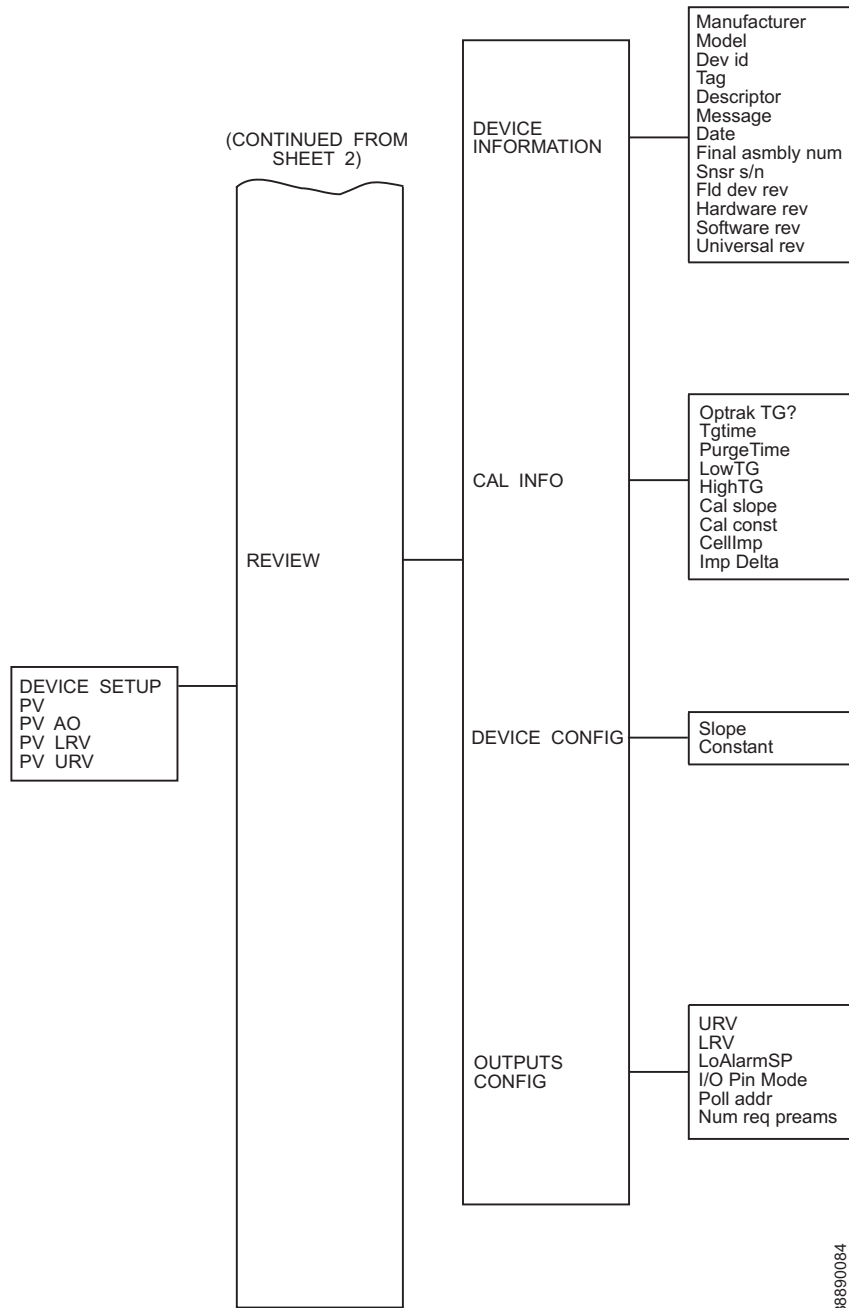

### HART COMMUNICATOR O<sub>2</sub> CAL METHOD

Use the following procedure to perform a calibration using the HART Communicator. If necessary, use the menu tree in Figure 7-3 (sheet 1 of 3) for reference.

#### NOTE

To select a menu item, either use the up and down arrow keys to scroll to the menu item and press the right arrow key or use the number keypad to select the menu item number. To return to a preceding menu, press the left arrow key.

1. From the PERFORM O<sub>2</sub> CAL screen, select menu item 1, O<sub>2</sub> CAL, to access the O<sub>2</sub> calibration procedure.

#### WARNING

Failure to remove the Oxymitter 4000 from automatic control loops prior to performing this procedure may result in a dangerous operating condition.

2. In the first O<sub>2</sub> CAL screen, a "Loop should be removed from automatic control" warning appears. Remove the Oxymitter 4000 from any automatic control loops to avoid a potentially dangerous operating condition and press OK.
3. The next several screens indicate the calibration status. At each of the following status prompts, select menu item 2, NEXT CAL STEP:  
COMPLETE  
CAL RECOMMENDED  
APPLY GAS 1  
GAS 1 FLOW
4. At this point, select menu item 4, EXIT, to leave the O<sub>2</sub> CAL procedure.
5. From the PERFORM O<sub>2</sub> CAL screen, view menu item 3, CALSTATE, to monitor the calibration status as it updates. Or, access the O<sub>2</sub> CALIBRATE screen and select menu item 2, O<sub>2</sub> CAL STATUS, to view menu item 1, CALSTATE; menu item 2, TIMEREMAIN; and menu item 3, PRESENT O<sub>2</sub>, as the calibration status updates.
6. When CALSTATE displays APPLY GAS 2, return to the O<sub>2</sub> CAL procedure.
7. When the "Loop should be removed from automatic control" warning appears, return the Oxymitter 4000 to the automatic control loops previously removed and press OK.
8. At the STOP GAS status prompt, select menu item 2, NEXT CAL STEP. When the status displays PURGING, select menu item 4, EXIT, to leave the O<sub>2</sub> CAL procedure.
9. From the PERFORM O<sub>2</sub> CAL screen, view menu item 3, CALSTATE, to monitor the calibration status as it updates. Or, access the O<sub>2</sub> CALIBRATE screen and select menu item 2, O<sub>2</sub> CAL STATUS, to view menu item 1, CALSTATE; menu item 2, TIMEREMAIN; and menu item 3, PRESENT O<sub>2</sub>, as the calibration status updates.
10. When CALSTATE displays STOP GAS, return to the O<sub>2</sub> CAL procedure.

11. When the "Loop should be returned to automatic control" message appears, return the Hazardous Area Oxymitter 4000 to the automatic control loops previously removed and press OK.
12. At the STOP GAS status prompt, select menu item 2, NEXT CAL STEP. When the status displays PURGING, select menu item 4, EXIT, to leave the O2 CAL procedure.
13. From the PERFORM O2 CAL screen, view menu item 3, CALSTATE, to monitor the calibration status as it updates. Or, access the O2 CALIBRATE screen and select menu item 2, O2 CAL STATUS, to view menu item 1, CAL-STATE; menu item 2, TIMEREMAIN; and menu item 3, PRESENT O2, as the calibration status updates.
14. When CALSTATE displays COMPLETE, the calibration is finished.

**DEFINING A TIMED CALIBRATION VIA HART**

Use the following procedure to specify a time interval (in hours) at which the Oxymitter 4000 will be automatically calibrated. If necessary, use the menu tree in Figure 7-3 (Sheet 2 of 3) for reference.

---

**NOTE**

To select a menu item, either use the up and down arrow keys to scroll to the menu item and press the right arrow key or use the number keypad to select the menu item number. To return to a preceding menu, press the left arrow key.

---

1. From the DEVICE SETUP screen, select DETAILED SETUP.
2. From the DETAILED SETUP screen, select O2 CALIBRATION.
3. From the O2 CALIBRATION screen, select menu item 6, CAL MODE. Set the CAL MODE to AUTO.
4. Return to the O2 CALIBRATION screen and select menu item 7, CAL INTRVL.
5. At the prompt, input a time interval (in hours) at which an automatic calibration will occur; then press ENTER.

**D/A TRIM PROCEDURE**

The D/A trim procedure is used to calibrate the 4-20 mA output signal to a precision mA measurement device (calibrated digital ammeter, etc.). The procedure is interactive and stored in the Oxymitter software.

Use one of the following communication methods to access the D/A trim procedure:

**LOI Menu**

1. Use the "Z" pattern key entry to access the LOI menu.
2. Press the down key two times to access the **SYSTEM** menu.
3. Press the down key once to access the **Input/Output** menu.
4. From the **Analog** selection, press the right-pointing key to display the Analog submenu listing.
5. Press the down key as needed to access **Trim O2 Out**.
6. Press the **Enter** key to start the trim procedure. Follow the LOI display prompts to perform the trim procedure.

# Oxymitter 4000

---

**Instruction Manual**

IM-106-340, Rev. 4.2

July 2008

## Section 8 Troubleshooting

---

Overview .....	page 8-1
General .....	page 8-3
Alarm Indications .....	page 8-3
Alarm Contacts .....	page 8-4
Identifying and Correcting Alarm Indications .....	page 8-5
Heater Not Open, but Unable to Reach 736°C Setpoint ..	page 8-22
Calibration Passes, but Still Reads Incorrectly .....	page 8-22

---

### OVERVIEW

While the Oxymitter 4000 electronics provides a significant number of diagnostic alarms to assist in troubleshooting potential problems, it is good to place these alarms in perspective with respect to the instrument's operating principles:

When the Zirconium Oxide sensing cell is heated to its setpoint [1357°F (736°C)], the cell will generate a voltage that represents the difference between the process O<sub>2</sub>% and the reference O<sub>2</sub>% inside the probe (20.95% O<sub>2</sub> ambient air).

Test points, Figure 8-1, are provided to read the raw millivolt value generated by the thermocouple that controls the cell temperature and also the raw cell signal.

The cell temperature at test points 3 and 4 should always be stable at approximately 29 to 30 millivolts, which represents the [1357°F (736°C)] setpoint temperature.

When flowing calibration gasses, the raw cell millivolt value at test points 1 and 2 should represent the levels on the chart in Figure 8-1. Note that the raw cell millivolt value increases logarithmically as the O<sub>2</sub> concentration decreases.

# Oxymitter 4000

Figure 8-1. O<sub>2</sub> Sensor mV Reading vs. % O<sub>2</sub> at 1357°F (736°C) (Reference Air, 20.9% O<sub>2</sub>)

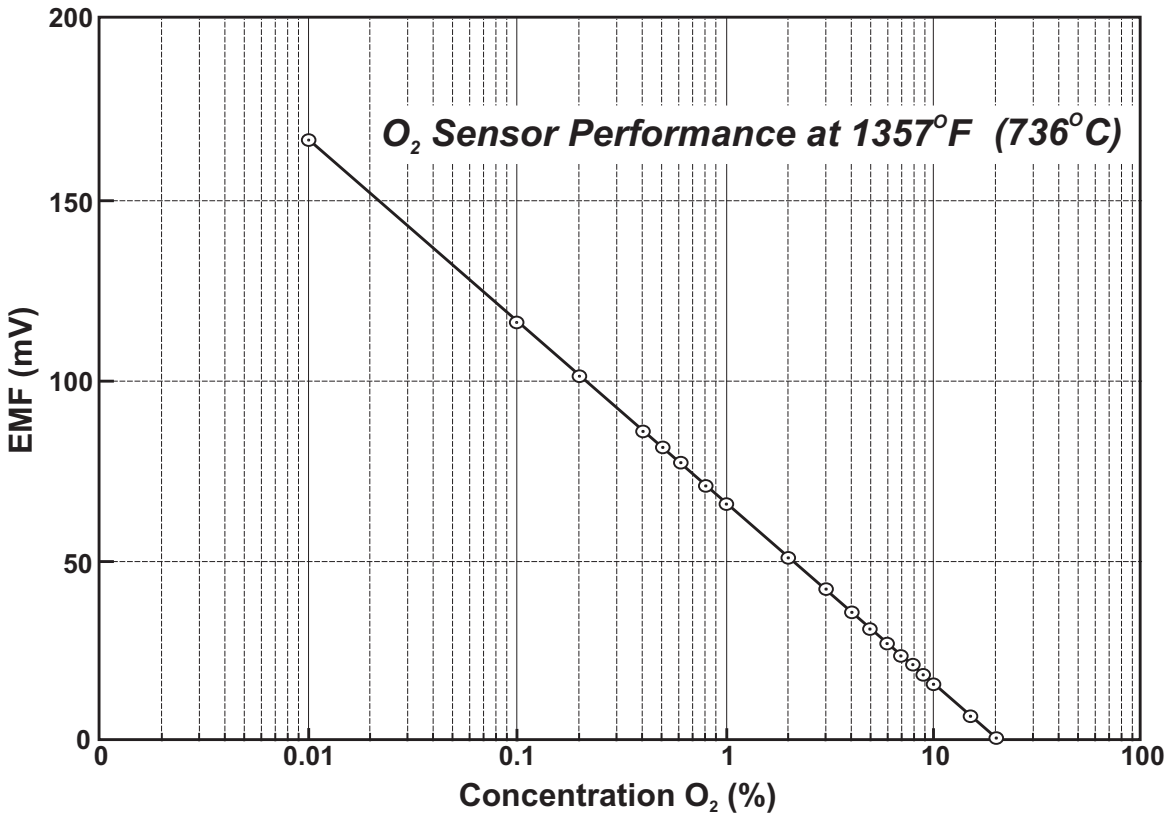

38890043

O <sub>2</sub> %	100	20	15	10	9	8	7	6	5	4
EMF(mV)	-34	1.0	7.25	16.1	18.4	21.1	23.8	27.2	31.2	36.0
O <sub>2</sub> %	3	2	1	0.8	0.6	0.5	0.4	0.2	0.1	0.01
EMF(mV)	42.3	51.1	66.1	71.0	77.5	81.5	86.3	101.4	116.6	166.8

**⚠ WARNING**

Install all protective equipment covers and safety ground leads after troubleshooting. Failure to install covers and ground leads could result in serious injury or death.

**GENERAL**

The troubleshooting section describes how to identify and isolate faults that may develop in the Oxymitter 4000. When troubleshooting, reference the following.

**Grounding**

It is essential that adequate grounding precautions are taken when installing the system. Thoroughly check both the probe and electronics to ensure the grounding quality has not degraded during fault finding. The system provides facilities for 100% effective grounding and the total elimination of ground loops.

**Electrical Noise**

The Oxymitter 4000 has been designed to operate in the type of environment normally found in a boiler room or control room. Noise suppression circuits are employed on all field terminations and main inputs. When fault finding, evaluate the electrical noise being generated in the immediate circuitry of a faulty system. Ensure all cable shields are connected to earth.

**Loose Integrated Circuits**

The Oxymitter 4000 uses a microprocessor and supporting integrated circuits (IC). If the electronics are handled roughly during installation or located where subjected to severe vibration, the ICs could work loose. Before troubleshooting the system, ensure all ICs are fully seated.

**Electrostatic Discharge**

Electrostatic discharge can damage the ICs used in the electronics. Before removing or handling the processor board or the ICs, ensure you are at ground potential.

**ALARM INDICATIONS**

The first indication of a problem at the analyzer usually comes from the Operators running the process. Critical alarms that render the O<sub>2</sub> measurement unusable will force the 4-20 mA analog output signal representing O<sub>2</sub> to go to a default condition, as follows:

<b>4-20 mA Signal Alarm Levels</b>	
<b>4-20 mA signal</b>	<b>Analyzer Condition</b>
0 mA	Analyzer unpowered, or completely failed
3.5 mA	Critical Alarm - analyzer reading unusable (factory default)
3.8 mA	Reading Under Range (Example - user sets range to 2-10%. Current reading is 1.9%)
4 to 20 mA	Normal Operation
20.5 mA	Reading Over Range (Example - range is 0-10%. Current reading is 12%)
>21 mA	Critical Alarm - analyzer reading is unusable (user can choose this alarm level instead of the factory default level of 3.5 to 3.6 mA)

**NOTE**

Make sure that the Control System is configured to interpret these signal levels correctly!

Once an alarm condition is identified, the Oxymitter 4000 electronics offers a number of diagnostics to interpret the specific alarm.

If the Oxymitter 4000 has the simple keypad operator interface, the majority of fault conditions will be indicated by one of the four LEDs referred to as diagnostic, or unit alarms on the operator's keypad (Figure 8-2). An LED will flash a code that will correspond to an error message. Only one LED will blink at a time. An alarm code guide is provided inside the screw-on cover for the electronics.

Alarm indications will also be available via the optional LOI or the HART Model 275/375 hand-held communicator and Rosemount Analytical's Asset Management software. When the error is corrected and/or power is cycled, the diagnostic alarms will clear or the next error on the priority list will appear.

Figure 8-2. Diagnostic LEDs

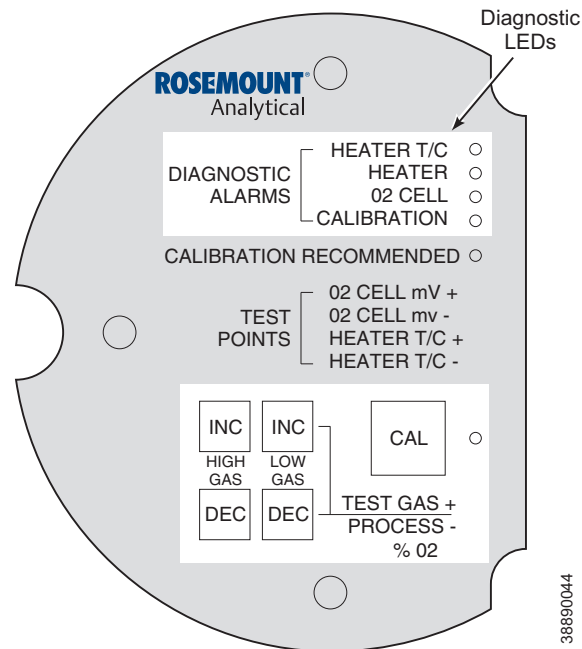

### ALARM CONTACTS

If autocalibration is not utilized, a common bidirectional logic contact is provided for any of the diagnostic alarms listed in Table 8-1. The assignment of alarms which can actuate this contact can be modified to one of seven additional groupings (mode 0 through mode 7) listed in Table 7-1.

The logic contact is self-powered, +5 VDC, with a 340 ohm series resistance. An interposing relay will be required if this contact is to be utilized to annunciate a higher voltage device, such as a light or horn. An interposing relay may also be required for certain DCS input cards.



A Potter & Brumfield R10S-E1Y1-J1.0K 3.2 mA DC or an equal interposing relay will be mounted where the contact wires terminate in the control/relay room.

If autocalibration systems are utilized, the bidirectional logic contact is utilized as a "hand-shake" signal between the autocalibration system (SPS 4001B or IMPS 4000) and is unavailable for alarming purposes. Additional contacts are provided through the autocalibration systems, noted below.

**SPS 4001B and IMPS 4000, 1-4 probes**

- One contact closure per probe from the control room to the SPS 4001B or IMPS 4000 for "calibration initiate".
- One contact output per probe from the SPS 4001B or IMPS 4000 to the control room for "in calibration" notification.
- One contact output per probe from the SPS 4001B or IMPS 4000 to the control room for "calibration failed" notification. (Includes output from pressure switch indicating "cal gas bottles empty").

**Additional IMPS 4000 Alarm Contacts**

- One contact per IMPS 4000 for "low calibration gas flowing".
- One contact per IMPS 4000 for "high calibration gas flowing".

---

**NOTE**

The 4-20 mA signal can be configured to respond normally during any calibration, or can be configured to hold the last O<sub>2</sub> value upon the initiation of calibration. Factory default is for the 4-20 mA signal to operate normally throughout calibration.

---

---

**NOTE**

Holding the last O<sub>2</sub> value may be useful if several probes are being averaged for the purpose of automatic control. Unless several probes are being averaged, always place any control loops using the O<sub>2</sub> signal into manual prior to calibrating.

---

**IDENTIFYING AND  
CORRECTING ALARM  
INDICATIONS**

For an Oxymitter 4000 with a membrane keypad, faults are indicated by four diagnostic, or unit, alarm LEDs. A pattern of repeating blinks define the problem. A condensed table of the errors and the corresponding blink codes can be found on the inside right cover of the electronics housing. Table 8-1 also identifies the blink code and fault status of each LED as well as the output of the 4-20 mA signal line and a fault number that corresponds to the troubleshooting instructions provided in this section.

For an Oxymitter 4000 with the optional LOI, alarm messages are displayed on the LOI display window when the alarm status display is accessed via the LOI menu. A listing of the alarm/fault messages and the related fault status descriptions and fault numbers are shown in Table 8-2.

# Oxymitter 4000

Table 8-1. Diagnostic/Unit Alarm Fault Definitions - Membrane Keypad Only

LED	Flashes	Status	4-20 mA Line	Fault	Recoverable
HEATER T/C	1	Open	3.5 mA (factory default)*	1	No
	2	Shorted	3.5 mA (factory default)*	2	No
	3	Reversed	3.5 mA (factory default)*	3	No
	4	A/D Comm Error	3.5 mA (factory default)*	4	No
HEATER	1	Open	3.5 mA (factory default)*	5	No
	2	High High Temp	3.5 mA (factory default)*	6	No
	3	High Case Temp	3.5 mA (factory default)*	7	Yes
	4	Low Temp	3.5 mA (factory default)*	8	Yes
	5	High Temp	3.5 mA (factory default)*	9	Yes
O <sub>2</sub> CELL	1	High mV	3.5 mA (factory default)*	10	Yes
	3	Bad	Track O <sub>2</sub>	11	Yes
	4	EEprom Corrupt	3.5 mA (factory default)*	12	No
CALIBRATION	1	Invalid Slope	Track O <sub>2</sub>	13	Yes
	2	Invalid Constant	Track O <sub>2</sub>	14	Yes
	3	Last Calibration Failed	Track O <sub>2</sub>	15	Yes
	**	Calibration Recommended	Track O <sub>2</sub>		Yes

\*Critical alarm conditions will render the O<sub>2</sub> measurement as unusable, and any of these events will cause the 4-20 mA signal to go to a user-selectable limit of 3.5 mA or 21.6 mA (position 3 of SW2). Factory default value is 3.5 mA. Alarms which are not self-clearing (Self-Clearing = NO) will require a reset. Perform the Reset Procedure in Section 2: Configuration of Oxymitter 4000 with Membrane Keypad to continue operation.

\*\*The CALIBRATION RECOMMENDED alarm flashes the Calibration Recommended LED on the operator's keypad.

Table 8-2. Diagnostic/Unit Alarm Fault Definitions - LOI

Message	Status	Fault Number	Self Clearing
O <sub>2</sub> T/C OPEN	Heater T/C Open	1	No
O <sub>2</sub> T/C SHORTED	Heater T/CShorted	2	No
O <sub>2</sub> T/C REVERSED	Heater T/C Polarity Reversed	3	No
ADC ERROR	A/D Comm Error	4	No
O <sub>2</sub> HEATER OPEN	O <sub>2</sub> Heater Open	5	No
VERY HI O <sub>2</sub> TEMP	Very High Process Temperature	6	No
BOARD TEMP HI	Electronics Overheated	7	Yes
O <sub>2</sub> TEMP LOW	Low Process Temperature	8	Yes
O <sub>2</sub> TEMP HI	High Process Temperature	9	Yes
O <sub>2</sub> CELL OPEN	O <sub>2</sub> Cell Open	10	Yes
O <sub>2</sub> CELL BAD	O <sub>2</sub> Cell Failed	11, 13, 14	Yes
EEPROM CORRUPT	EEprom Failed	12	No
CALIB FAILED	Last Calibration Failed	15	Yes
LINE FREQ ERROR	Incorrect Input Line Frequency Detected on Power Up		No

Figure 8-3. Fault 1, Open Thermocouple

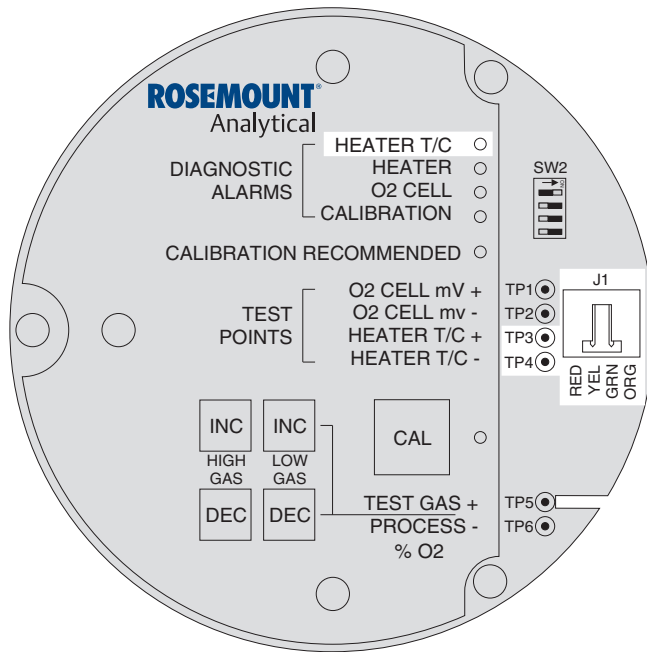

KEYPAD

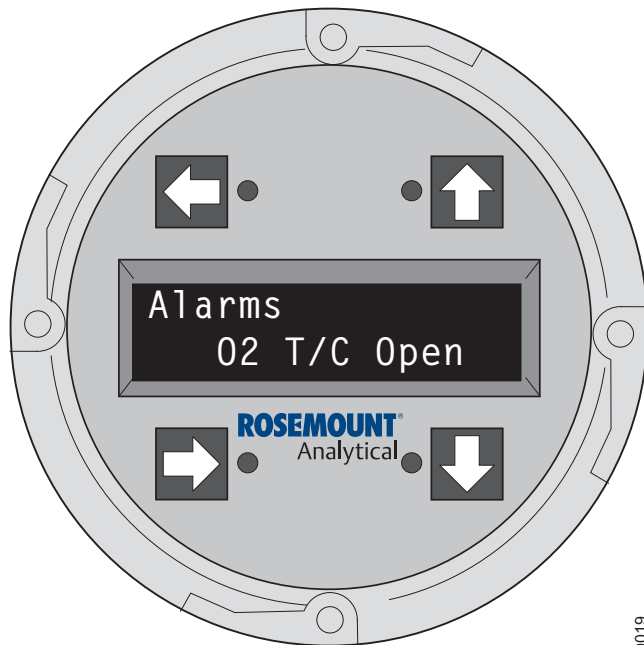

LOI

38890019

**Fault 1, Open Thermocouple**

Figure 8-3 shows the electronic assembly for an Oxymitter 4000 with a membrane keypad (upper view) and a Oxymitter 4000 with an LOI (lower view). The upper view also shows J1 and test points TP1 through TP6, located on the microprocessor board, below the membrane keypad or the LOI module.

**Membrane Keypad**

When Fault 1 is detected, the HEATER T/C LED flashes once, pauses for three seconds, and repeats.

1. Check connector J1. Ensure the connector is properly seated.
2. Using a multimeter, measure the voltage from TP3+ to TP4-. If the reading is 1.2 VDC  $\pm$ 0.1 VDC, the thermocouple is open.
3. Remove power. Disconnect J1. Measure the resistance across the red and yellow thermocouple leads. The resistance should be approximately 1 ohm.
4. If the thermocouple is open, see "Heater Strut Replacement" in Section 9: Maintenance and Service.

**LOI**

When Fault 1 is detected, the LOI displays the "O2 T/C Open" message.

1. Remove power. Unscrew and remove the LOI module from the electronic assembly.
2. Reconnect power to the Oxymitter 4000.
3. Perform the diagnostic steps 1 through 4 shown for the membrane keypad.

# Oxymitter 4000

Figure 8-4. Fault 2, Shorted Thermocouple

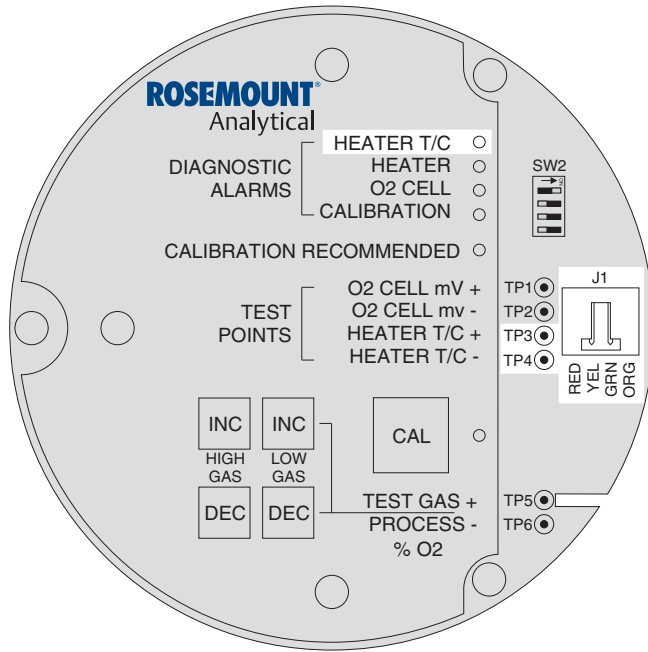

KEYPAD

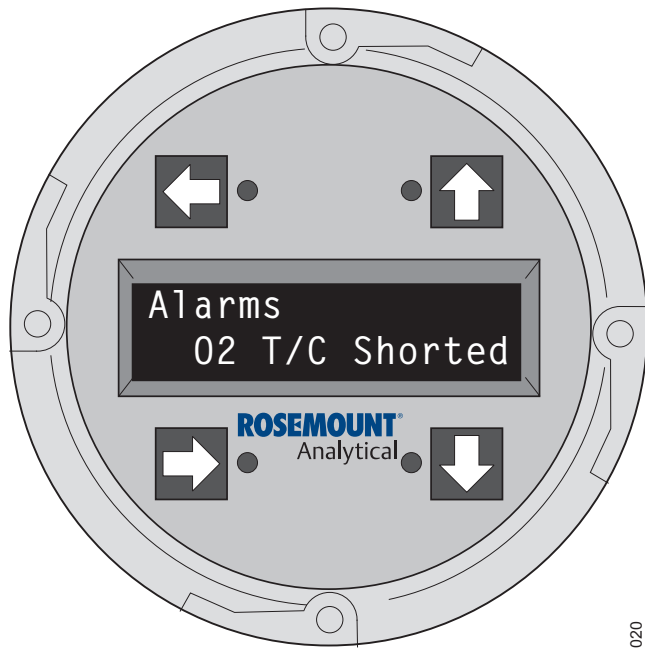

LOI

38890020

## Fault 2, Shorted Thermocouple

Figure 8-4 shows the electronic assembly for an Oxymitter 4000 with a membrane keypad (upper view) and an Oxymitter 4000 with an LOI (lower view). The upper view also shows J1 and test points TP1 through TP6, located on the microprocessor board, below the membrane keypad or the LOI module.

### Membrane Keypad

When Fault 2 is detected, the HEATER T/C LED flashes twice, pauses for three seconds, and repeats.

1. Using a multimeter, measure the voltage from TP3+ to TP4-. If the reading is  $0 \pm 0.5$  mV, then a shorted thermocouple is likely.
2. Remove power and disconnect J1.
3. Measure the resistance from TP3+ to TP4-. The reading should be approximately 20K ohms.
4. If so, the short is not on the PC board. The thermocouple wiring or the thermocouple is shorted. See "Heater Strut Replacement" in Section 9: Maintenance and Service.

### LOI

When Fault 2 is detected, the LOI displays the "O2 T/C Shorted" message.

1. Remove power. Unscrew and remove the LOI module from the electronic assembly.
2. Reconnect power to the Oxymitter 4000.
3. Perform the diagnostic steps 1 through 4 shown for the membrane keypad.

Figure 8-5. Fault 3, Reversed Thermocouple

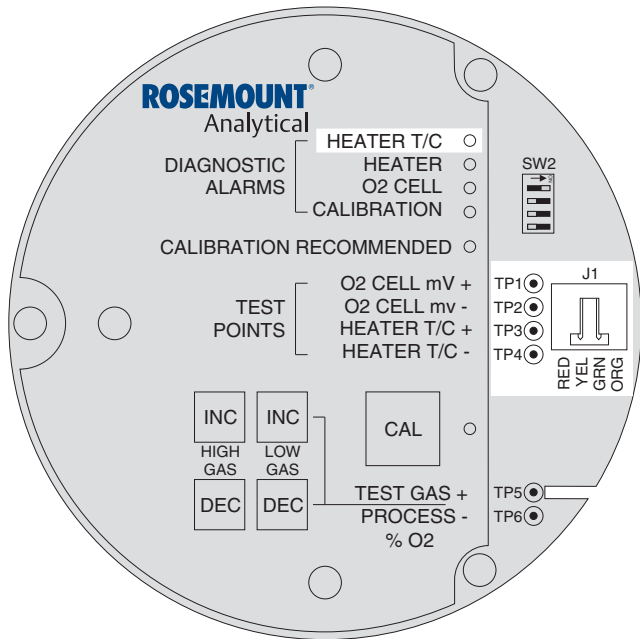

**KEYPAD**

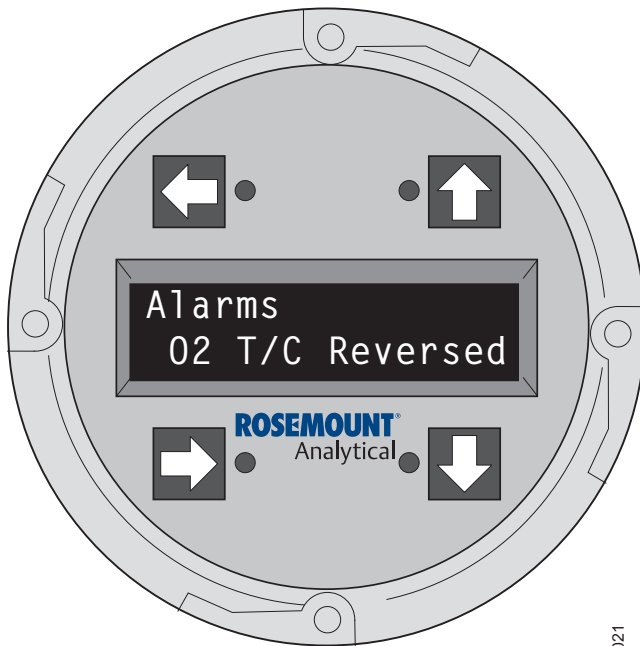

**LOI**

38890021

**Fault 3, Reversed Thermocouple Wiring or Faulty PC Board**

Figure 8-5 shows the electronic assembly for an Oxymitter 4000 with a membrane keypad (upper view) and an Oxymitter 4000 with an LOI (lower view). The upper view also shows J1 and test points TP1 through TP6, located on the microprocessor board, below the membrane keypad or the LOI module.

**Membrane Keypad**

When Fault 3 is detected, the HEATER T/C LED flashes three times, pauses for three seconds, and repeats.

1. Using a multimeter, measure the voltage from TP3+ to TP4-. If the reading is negative, the thermocouple wiring is reversed.
2. Check red and yellow wires in the J1 connector for the proper placement.
3. If the wiring is correct, the fault is in the PC board. See "Electronic Assembly Replacement" in Section 9: Maintenance and Service.

**LOI**

When Fault 3 is detected, the LOI displays the "O2 T/C Reversed" message.

1. Remove power. Unscrew and remove the LOI module from the electronic assembly.
2. Reconnect power to the Oxymitter 4000.
3. Perform the diagnostic steps 1 through 3 shown for the membrane keypad.

# Oxymitter 4000

Figure 8-6. Fault 4, A/D Comm Error

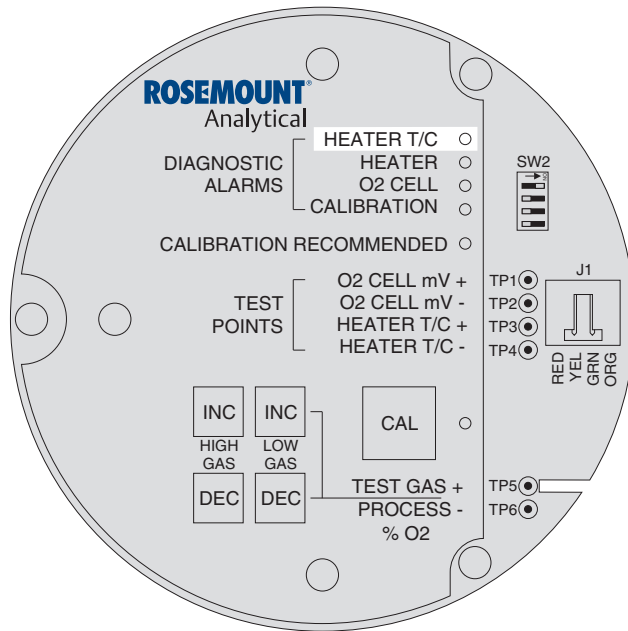

KEYPAD

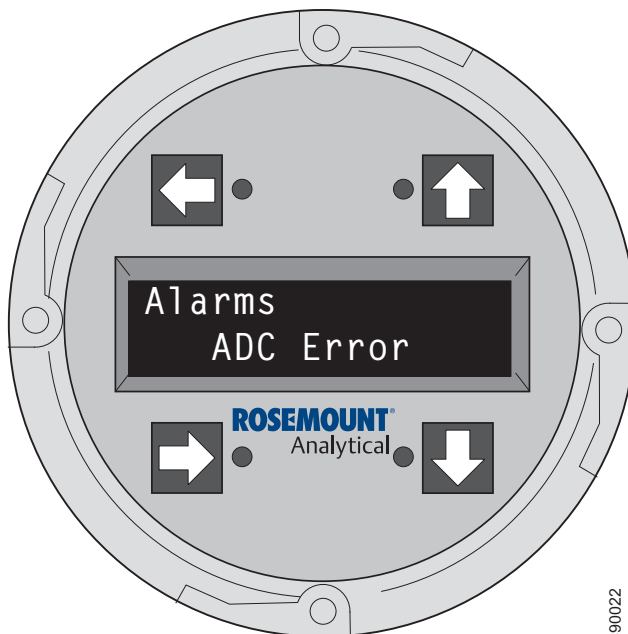

LOI

38890022

## Fault 4, A/D Comm Error

### Membrane Keypad

When Fault 4 is detected, the HEATER T/C LED flashes four times, pauses for three seconds, and repeats (Figure 8-6).

1. Call the factory for assistance.

### LOI

When Fault 4 is detected, the LOI displays the "ADC Error" message.

1. Call the factory for assistance.

Figure 8-7. Fault 5, Open Heater

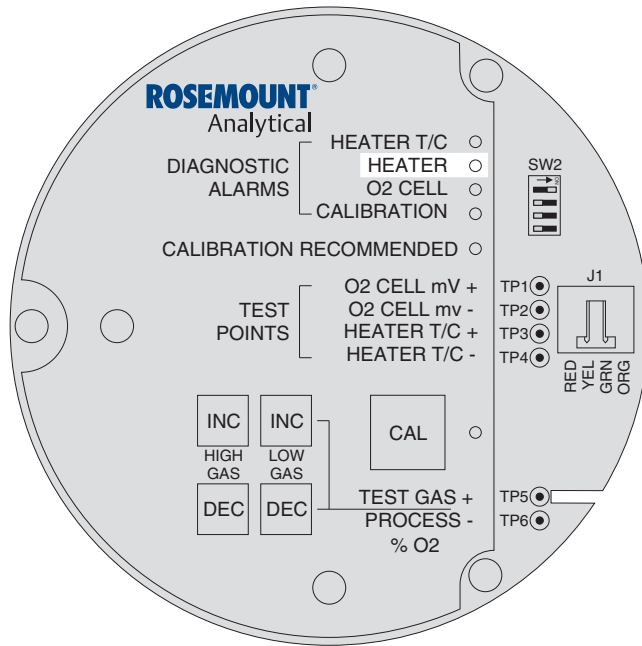

**KEYPAD**

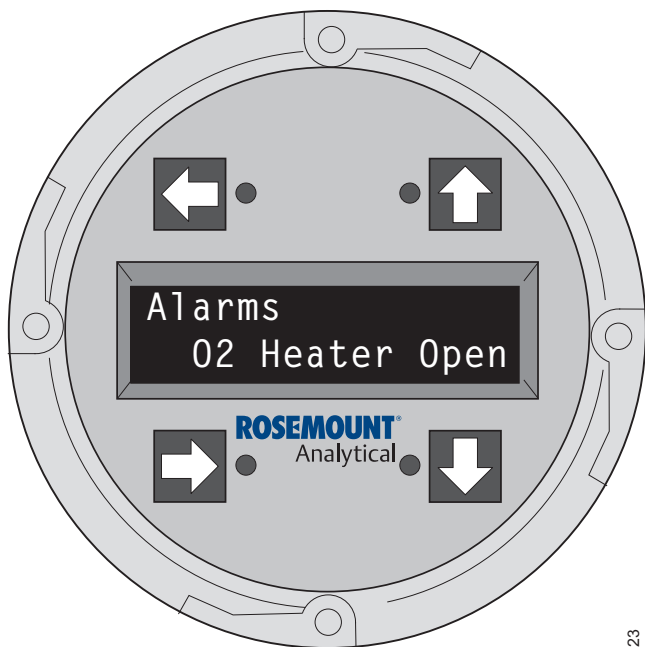

**LOI**

368890023

**Fault 5, Open Heater**

Figure 8-7 shows the electronic assembly for an Oxymitter 4000 with a membrane keypad (upper view) and a Oxymitter 4000 with an LOI (lower view).

**Membrane Keypad**

When Fault 5 is detected, the HEATER LED flashes once, pauses for three seconds, and repeats.

1. Remove power.
2. Remove the electronic assembly per "Electronic Assembly Replacement" in Section 9: Maintenance and Service.
3. Using a multimeter, measure the resistance across the terminals of heater connector, J8.
4. The measurement should be approximately 72 ohms. If the heater is open, see "Heater Strut Replacement" in Section 9: Maintenance and Service.

**LOI**

When Fault 5 is detected, the LOI displays the "O2 Heater Open" message.

1. Remove power. Unscrew and remove the LOI module from the electronic assembly.
2. Perform the diagnostic steps 2 through 4 shown for the membrane keypad.

# Oxymitter 4000

Figure 8-8. Fault 6, High High Heater Temp

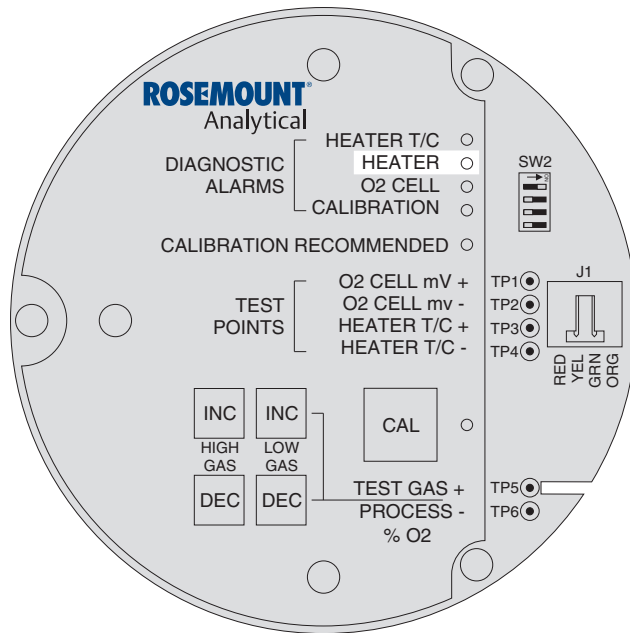

KEYPAD

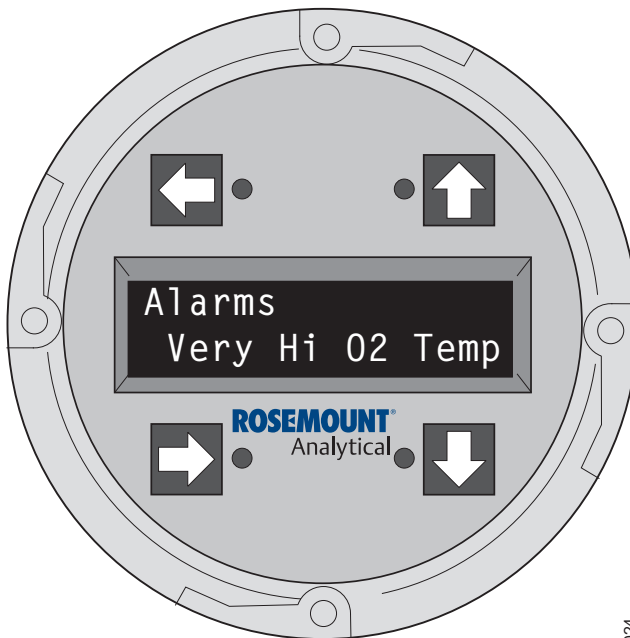

LOI

38890024

## Fault 6, High High Heater Temp

Figure 8-8 shows the electronic assembly for an Oxymitter 4000 with a membrane keypad (upper view) and an Oxymitter 4000 with an LOI (lower view).

### Membrane Keypad

When Fault 6 is detected, the HEATER LED flashes twice, pauses for three seconds, and repeats.

1. The High High Heater Temp alarm will activate when the thermocouple produces a voltage of 37.1 mV [1652°F (900°C)].
2. The triac and the temperature control may be at fault.
3. Remove power. Allow Oxymitter 4000 to cool for five minutes. Restore power.
4. If the condition repeats, replace the electronic assembly per "Electronic Assembly Replacement" in Section 9: Maintenance and Service.

### LOI

When Fault 6 is detected, the LOI displays the "Very Hi O2 Temp" message.

1. The very high O2 temperature alarm will activate when the thermocouple produces a voltage of 37.1 mV [1652°F (900°C)].
2. The triac and the temperature control may be at fault.
3. Remove power. Allow the Oxymitter 4000 to cool for five minutes. Restore power.
4. If the condition repeats, replace the electronic assembly per "Electronic Assembly Replacement" in Section 9: Maintenance and Service.



Figure 8-9. Fault 7, High Case Temp

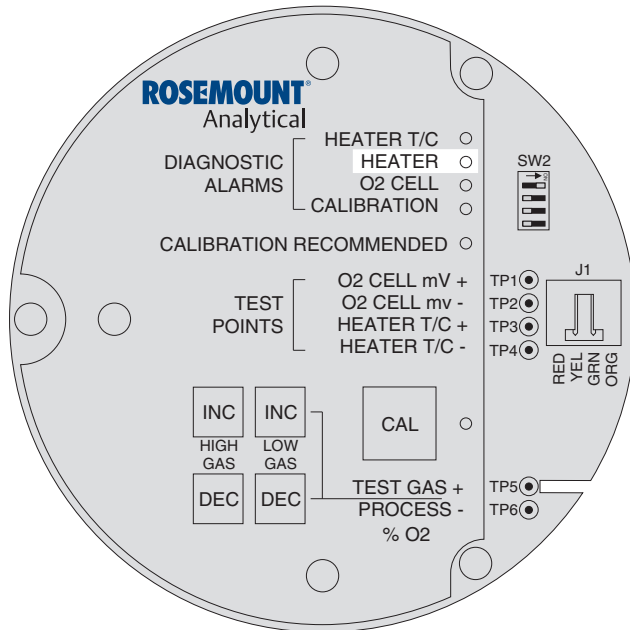

**KEYPAD**

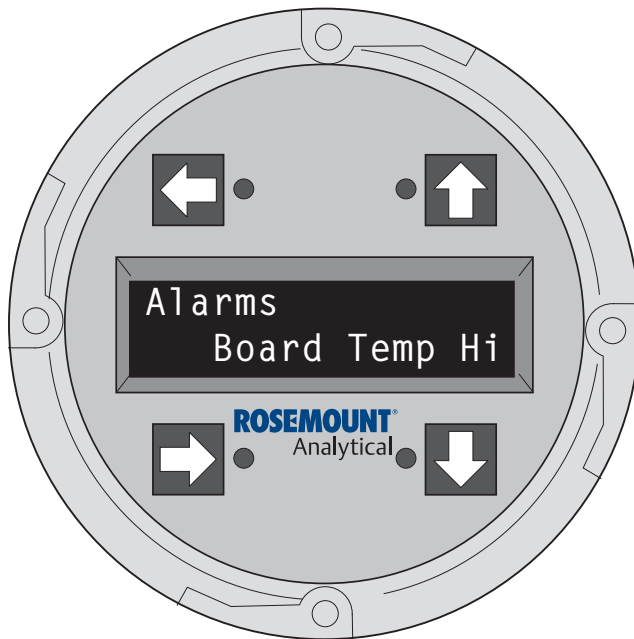

**LOI**

38890025

**Fault 7, High Case Temp**

Figure 8-9 shows the electronic assembly for an Oxymitter 4000 with a membrane keypad (upper view) and an Oxymitter 4000 with an LOI (lower view).

**Membrane Keypad**

When Fault 7 is detected, The HEATER LED flashes three times, pauses for three seconds, and repeats.

1. If the case temperature exceeds [185°F (85°C)], the temperature control will shut off and the 4-20 mA signal output will go to the default value.
2. This signifies that the environment where the Oxymitter 4000 is installed exceeds the ambient temperature requirements or that heat due to convection is causing case temperature to rise above the limit.
3. Placing a spool piece between the stack flange and the Oxymitter 4000 flange may eliminate this problem.
4. If a spool piece does not solve the problem, relocation is the only solution.

**LOI**

When Fault 7 is detected, the LOI displays the "Board Temp Hi" message. Refer to the comments in paragraphs 1 through 4 above.

# Oxymitter 4000

Figure 8-10. Fault 8, Low Heater Temp

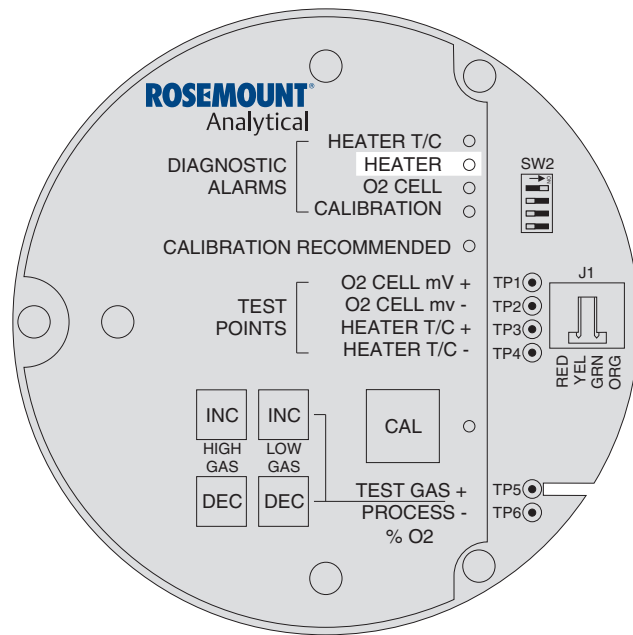

KEYPAD

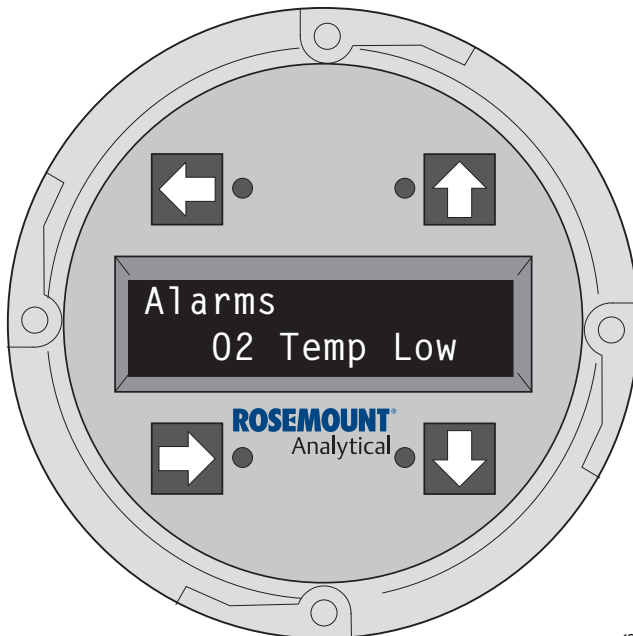

LOI

38890026

## Fault 8, Low Heater Temp

Figure 8-10 shows the electronic assembly for an Oxymitter 4000 with a membrane keypad (upper view) and an Oxymitter 4000 with an LOI (lower view).

### Membrane Keypad

When Fault 8 is detected, the HEATER LED flashes four times, pauses for three seconds, and repeats.

1. The low heater temperature alarm is active when the thermocouple reading has dropped below 28.6 mV.
2. If the thermocouple reading continues to ramp downward for one minute and does not return to the temperature set point of approximately 29.3 mV, then an Open Heater fault will be displayed.
3. Power down the electronics. Remove the electronic assembly per "Electronic Assembly Replacement" in Section 9: Maintenance and Service. Using a multimeter, measure the resistance across the terminals of heater connector, J8.
4. If the heater is good, the reading will be approximately 70 ohms. If the heater is open, see "Heater Strut Replacement" in Section 9: Maintenance and Service.

### LOI

When Fault 8 is detected, the LOI displays the "O2 Temp Low" message. Refer to the comments and procedures in paragraphs 1 through 4 above.

Figure 8-11. Fault 9, High Heater Temp

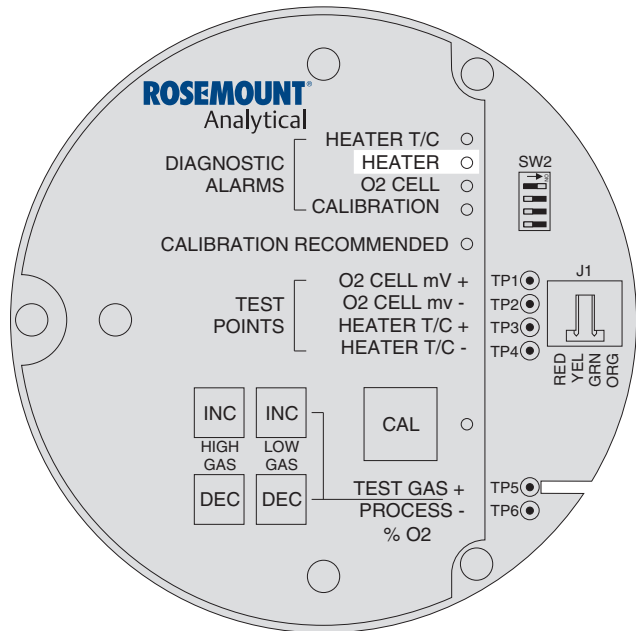

**KEYPAD**

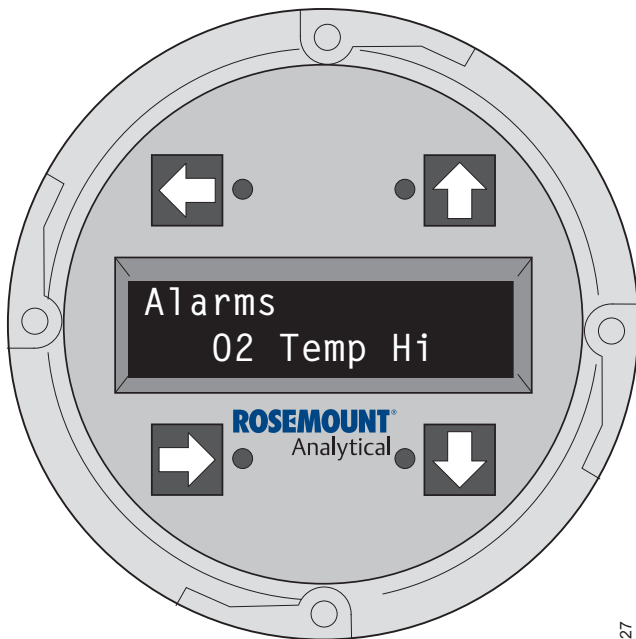

**LOI**

38890027

**Fault 9, High Heater Temp**

Figure 8-11 shows the electronic assembly for an Oxymitter 4000 with a membrane keypad (upper view) and an Oxymitter 4000 with an LOI (lower view).

**Membrane Keypad**

When Fault 9 is detected, the HEATER LED flashes five times, pauses for three seconds, and repeats.

1. If the thermocouple produces a voltage in excess of approximately 30.7 mV, the high heater temp alarm activates.
2. The 4-20 mA signal returns to the default value (4 or 20 mA).
3. This alarm is self-clearing. When temperature control is restored and the thermocouple voltage returns to the normal range, the alarm clears.
4. If the temperature continues to rise, the next alarm will be the High High Heater Temp alarm.

**LOI**

When Fault 9 is detected, the LOI displays the "O2 Temp Hi" message. Refer to the comments and procedures in paragraphs 1 through 4 above.

Figure 8-12. Fault 10, High Cell mV

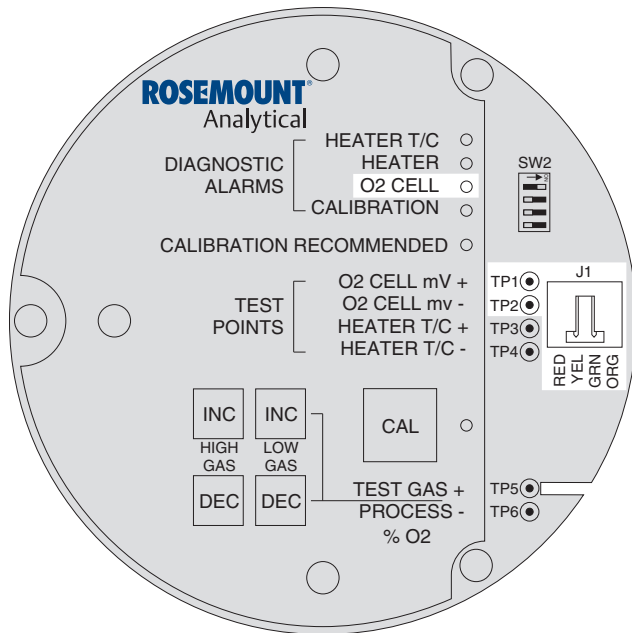

KEYPAD

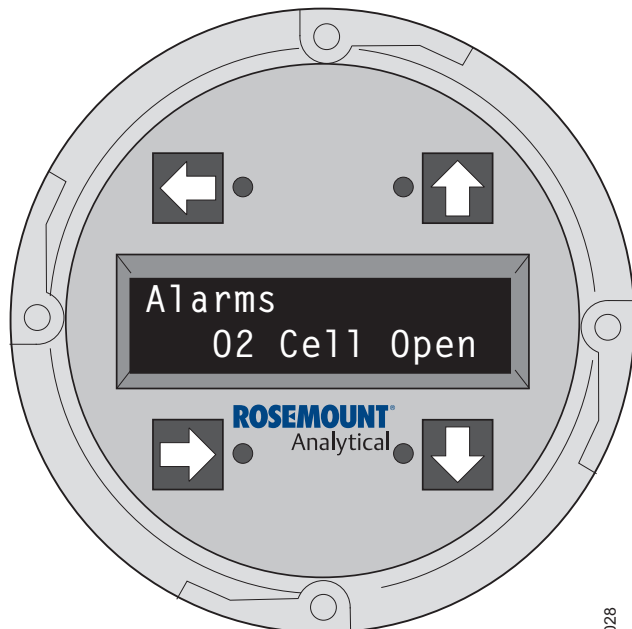

LOI

38890028

### Fault 10, High Cell mV

Figure 8-12 shows the electronic assembly for an Oxymitter 4000 with a membrane keypad (upper view) and an Oxymitter 4000 with an LOI (lower view). The upper view also shows J1 and test points TP1 through TP6, located on the microprocessor board, below the membrane keypad or the LOI module.

### Membrane Keypad

When Fault 10 is detected, the O2 CELL flashes once, pauses for three seconds, and repeats.

1. Using a multimeter, measure across TP1+ to TP2-. If you measure 204 mV to 1 volt DC, the cell reading is due to high combustibles. This is a self-clearing alarm, once the combustible conditions go away. If you measure 1.2 VDC, the cell wires, either orange or green, have become detached from the input.
2. One possible cause is connector J1. The orange or green wire has come loose from the crimped connection.
3. The platinum pad could also be at fault. The pad could have broken free from the back of the cell.
4. Replace heater strut per "Heater Strut Replacement" in Section 9: Maintenance and Service. If necessary, replace the cell and flange assembly per "Cell Replacement" in Section 9: Maintenance and Service.

### LOI

When Fault 10 is detected, the LOI displays the "O2 Cell Open" message.

1. Remove power. Unscrew and remove the LOI module from the electronic assembly.
2. Reconnect power to the Oxymitter 4000.
3. Perform the diagnostic steps 1 through 4 shown for the membrane keypad.

Figure 8-13. Fault 11, Bad Cell

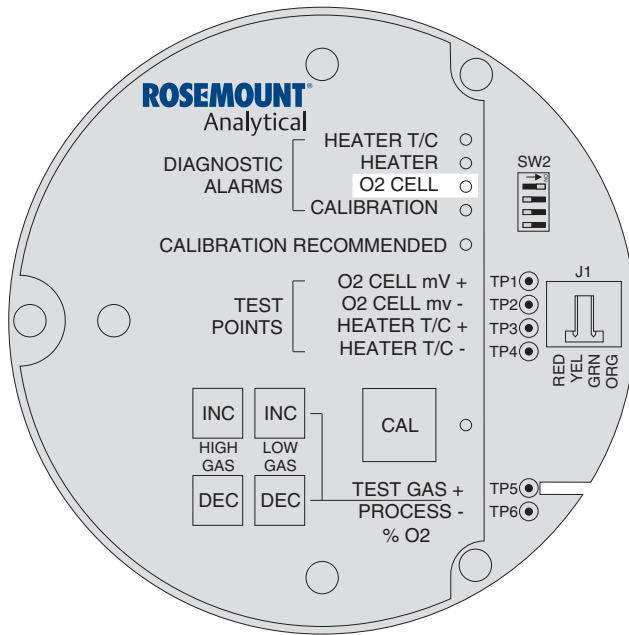

**KEYPAD**

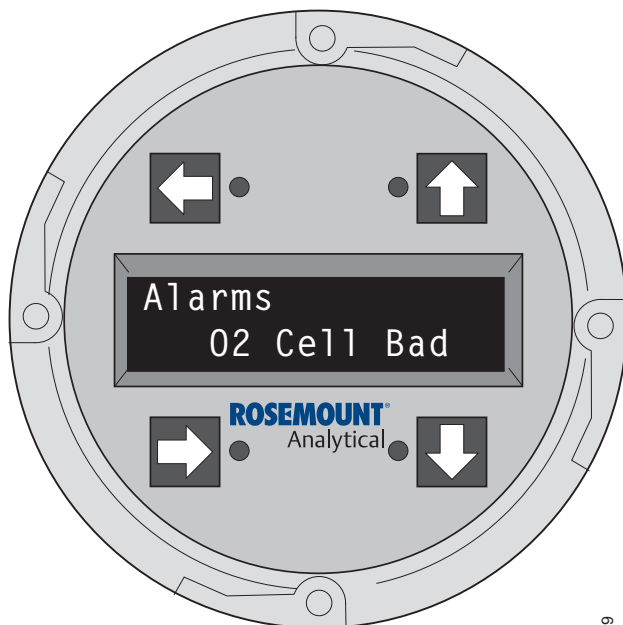

**LOI**

38890029

**Fault 11, Bad Cell**

Figure 8-13 shows the electronic assembly for an Oxymitter 4000 with a membrane keypad (upper view) and an Oxymitter 4000 with an LOI (lower view).

**Membrane Keypad**

When Fault 11 is detected, the O2 CELL flashes three times, pauses for three seconds, and repeats.

1. The bad cell alarm activates when the cell exceeds the maximum resistance value.
2. The cell should be replaced. See "Cell Replacement" in Section 9: Maintenance and Service, for cell replacement instructions.

**LOI**

When Fault 11 is detected, the LOI displays the "O2 Cell Bad" message. Refer to the comments and procedures in paragraphs 1 and 2 above.

# Oxymitter 4000

Figure 8-14. Fault 12, EEprom Corrupt

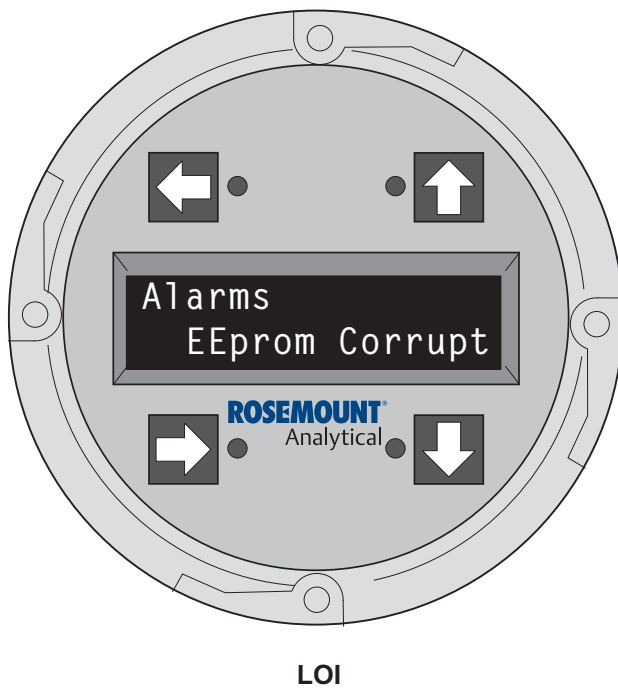
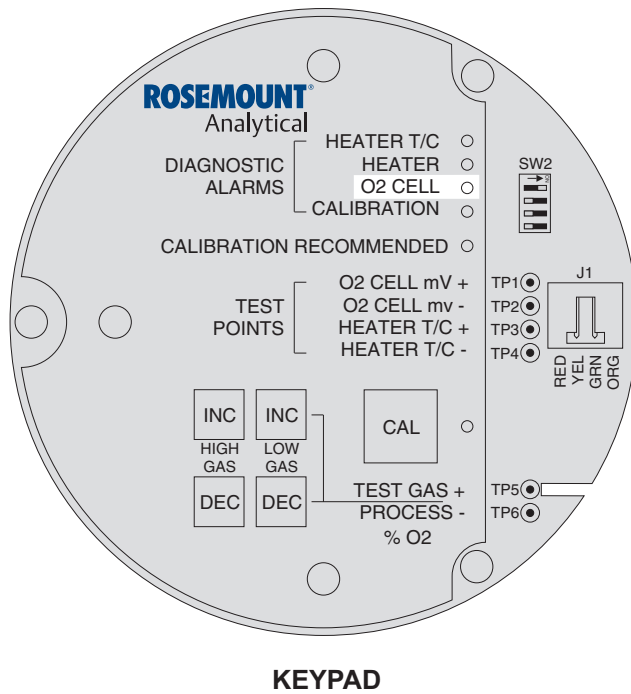

38890030

## Fault 12, EEprom Corrupt

Figure 8-14 shows the electronic assembly for an Oxymitter 4000 with a membrane keypad (upper view) and an Oxymitter 4000 with an LOI (lower view).

### Membrane Keypad

When Fault 12 is detected, the O2 CELL LED flashes four times, pauses for three seconds, and repeats.

1. This alarm can occur if the EEprom is changed for a later version. At power up, the EEprom is not updated.
2. To correct this problem, power down and then restore power. The alarm should clear.
3. If the alarm occurs while the unit is running, there is a hardware problem on the microprocessor board.
4. If cycling the power does not clear the alarm, see "Electronic Assembly Replacement" in Section 9: Maintenance and Service.

### LOI

When Fault 12 is detected, the LOI displays the "EEprom Corrupt" message. Refer to the comments and procedures in paragraphs 1 through 4 above.

Figure 8-15. Fault 13, Invalid Slope

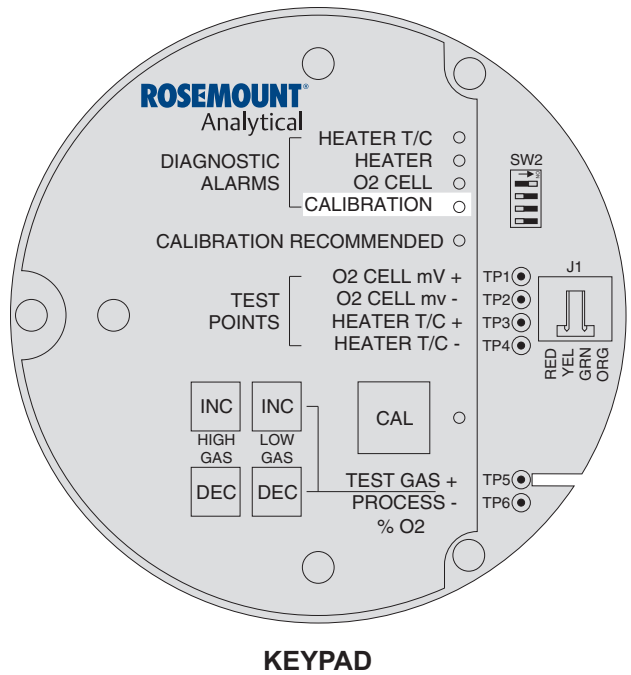

KEYPAD

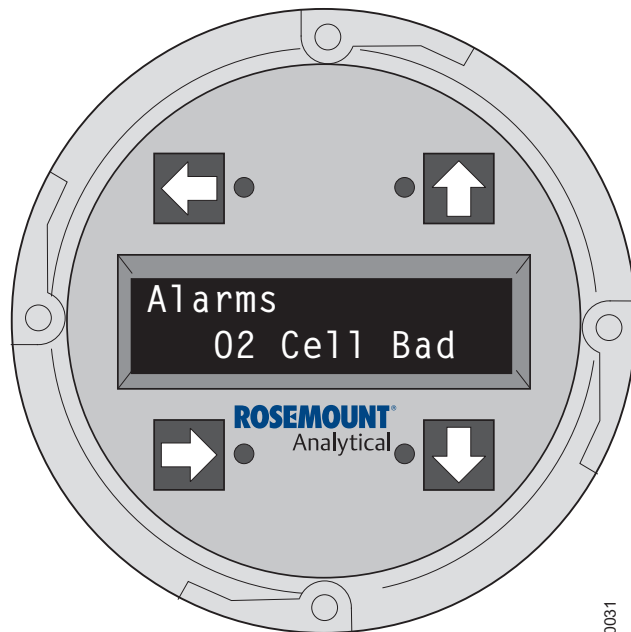

LOI

38890031

**Fault 13, Invalid Slope**

Figure 8-15 shows the electronic assembly for an Oxymitter 4000 with a membrane keypad (upper view) and an Oxymitter 4000 with an LOI (lower view).

**Membrane Keypad**

When Fault 13 is detected, the CALIBRATION LED flashes once, pauses for three seconds, and repeats.

1. During a calibration, the electronics calculates a slope value. If the value of the slope is less than 35 mV/dec or more than 52 mV/dec, the slope alarm will be active until the end of the purge cycle.
2. See "Calibration with Keypad" in Section 9: Maintenance and Service. Verify the calibration by carefully repeating it. Ensure the calibration gases match the calibration gas parameters. If you attach a multimeter to TP1+ and TP2-, sample gas measurements are:
  - 8% O<sub>2</sub> ≈ 23 mV
  - 0.4% O<sub>2</sub> ≈ 85 mV
3. Power down the Oxymitter 4000 and remove it from the stack.
4. Replace the cell per "Cell Replacement" in Section 9: Maintenance and Service.

**LOI**

When Fault 13 is detected, the LOI displays the "O2 Cell Bad" message. Refer to the comments and procedures in paragraphs 1 through 4 above.

# Oxymitter 4000

Figure 8-16. Fault 14, Invalid Constant

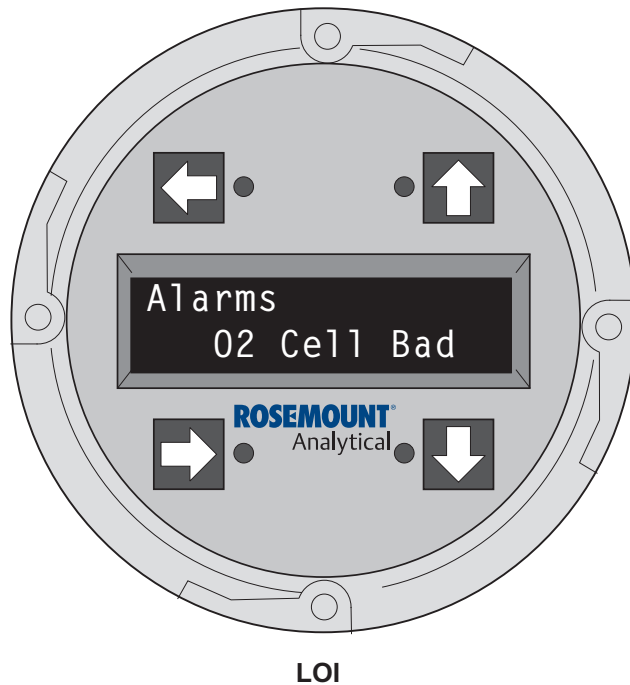
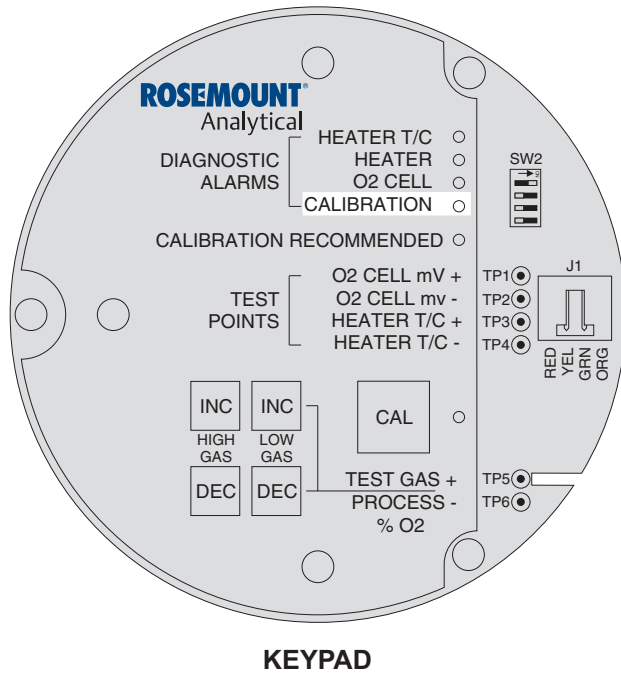

38890032

## Fault 14, Invalid Constant

Figure 8-16 shows the electronic assembly for an Oxymitter 4000 with a membrane keypad (upper view) and an Oxymitter 4000 with an LOI (lower view).

### Membrane Keypad

When Fault 14 is detected, the CALIBRATION LED flashes twice, pauses for three seconds, and repeats.

1. After a calibration has been performed, the electronics calculates a cell constant value.
2. If the cell constant value is outside of the range, -4 mV to 10 mV, the alarm will activate. See "Calibration with Keypad" in Section 9: Maintenance and Service, and verify the last calibration was performed correctly.
3. Power down the Oxymitter 4000 and remove it from the stack.
4. Replace the cell per "Cell Replacement" in Section 9: Maintenance and Service.

### LOI

When Fault 14 is detected, the LOI displays the "O2 Cell Bad" message. Refer to the comments and procedures in paragraphs 1 through 4 above.



Figure 8-17. Fault 15, Last Calibration Failed

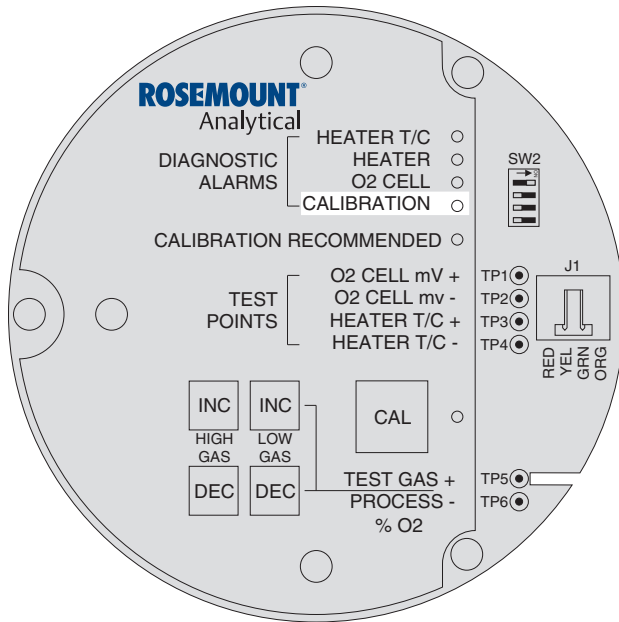

**KEYPAD**

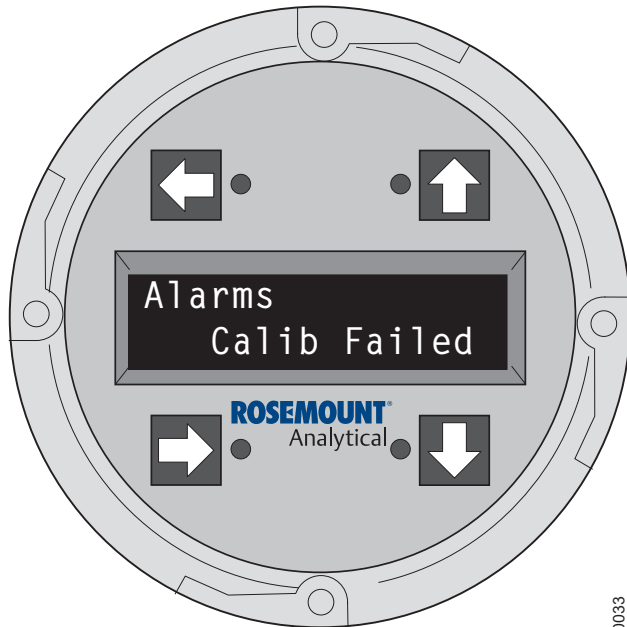

**LOI**

38890033

**Fault 15, Last Calibration Failed**

Figure 8-17 shows the electronic assembly for an Oxymitter 4000 with a membrane keypad (upper view) and an Oxymitter 4000 with an LOI (lower view).

**Membrane Keypad**

When Fault 15 is detected, the CALIBRATION LED flashes three times, pauses for three seconds, and repeats.

1. The last calibration failed alarm activates when the slope and constant values calculated are out of range and the unit reverts to using the previous calibration values.
2. The cell should be replaced. See "Cell Replacement" in Section 9: Maintenance and Service, for cell replacement instructions.

**LOI**

When Fault 15 is detected, the LOI displays the "Calib Failed" message. Refer to the comments in paragraphs 1 and 2 above.

# Oxymitter 4000

## HEATER NOT OPEN, BUT UNABLE TO REACH 736°C SETPOINT

The temperature setpoint of 736°C can not be reached because the Oxymitter 5000 has an "autotune" function for establishing heater control parameters. Probes mounted into processes that operate at above 600°C may have a hard time controlling the temperature with the "autotune" function enabled. To disable the autotune function, conduct the following procedure with the LOI.

1. Select System.
2. Select Parameters.
3. Select Auto Tune?
4. Select No to disable the Auto Tune function.

## CALIBRATION PASSES, BUT STILL READS INCORRECTLY

There are a few fault conditions where no alarm indication is present and the probe passes calibration but the O<sub>2</sub> reading may still be incorrect:

### Probe passes calibration, but still appears to read high

There may be a leak that is permitting ambient air to mix with the process gases. Since many combustion processes are slightly negative in pressure, ambient air can be sucked into the cell area, biasing the O<sub>2</sub> reading upward.

1. Make sure that the calibration gas line is capped tightly between calibrations. If autocal is used make sure the check valve is seating properly.
2. If an abrasive shield is installed to protect the entire probe from particulate erosion, a leak in the probe flange gasket can allow ambient air to migrate down the annular space between the probe and shield, and then into the cell. Always install a new probe flange gasket when reinstalling a probe.

There may be a leak inside the probe itself, permitting the reference air (20.95% O<sub>2</sub>) to mix with the process gases at the cell. To confirm this leak condition instrument air will need to be connected for reference. Pressurize the inside (reference side) of the probe by plugging the reference air exhaust port with your finger for 1 minute. The O<sub>2</sub> reading should decrease slightly. If the O<sub>2</sub> reading increases during this test there is a leak inside the probe.

1. Acid condensation inside the probe can degrade the red silicon tube (28, Figure 9-3) that carries the cal gas to the cell. Remove housing (21) to inspect this hose. (See Section 9: Maintenance and Service). Black vitan material is optionally available with greater chemical resistance.

Figure 8-18. Probe Leakage Paths

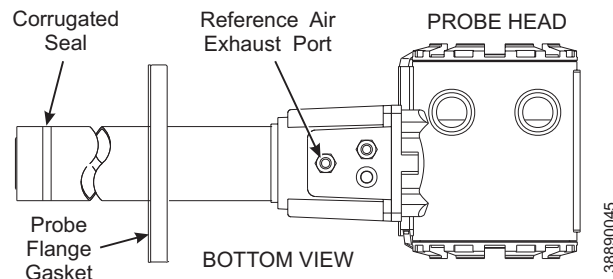

2. The sensing cell is bolted to the end of the probe and uses a corrugated metallic seal (5, Figure 9-3) to separate the process gases from the ambient reference air. This seal can be used only one time so always replace this seal when a cell is removed or replaced. Always apply anti-seize compound on both sides of the corrugations.

#### **Probe passes calibration, but still appears to read low**

The diffusion element at the end of the probe is a passive filter. It plugs very slowly since there is no active flow being drawn across it. In applications that have a heavy particulate loading (coal or wood fired boilers, cement and lime kilns, catalyst regeneration, recovery boilers, etc.), this diffusion element will eventually plug.

It is important not to pressurize the sensing cell during calibrations by flowing excessive cal gas against a plugged diffuser. Calibration flow rates should be set only when a new diffuser is installed. As the diffuser plugs do not adjust the flow rates upward.

#### **How do I detect a plugged diffuser?**

The O<sub>2</sub> signal's speed of response will degrade. The O<sub>2</sub> trend in the control room will become smoother.

When calibrating, the calibration gas flow rate will be noted to be lower. Never readjust this flow upwards. Adjust this flow only when a new diffuser is installed.

Always note the time it takes for the cell to recover to the normal process value after the cal gas is removed. As the diffuser plugs this recovery time will get longer and longer. Use the Calibration Record form provided in this manual.

#### **Can I calibrate a badly plugged diffuser?**

It may not be possible to immediately replace a plugged diffuser while the process is on line.

One can calibrate the probe without pressurizing the cell by adjusting the calibration gas flow rate downward before calibration. For instance, say the process is at 3% and the first calibration gas is 8%. Adjust the flow of cal gas downward until the reading begins to migrate from 8% to lower values indicating that process gases are now mixing in with the calibration gases.

Adjust the flow rate back up until this mixing is just eliminated. Calibrate at this flow rate. Replace the diffuser at the first opportunity.

#### **WARNING**

Install all protective equipment covers and safety ground leads after troubleshooting. Failure to install covers and ground leads could result in serious injury or death.

**Calibration Record**  
**For**  
**Rosemount Analytical In Situ O<sub>2</sub> Probe**

Probe Serial Number: \_\_\_\_\_

Probe Tag Number: \_\_\_\_\_

Probe Location: \_\_\_\_\_

Date Placed Into Service: \_\_\_\_\_

Date	Slope	Constant	Impedance	Response <sub>initial</sub>	Response <sub>final</sub>

**Notes:** Response<sub>initial</sub> When the second calibration gas is turned off, note the number of seconds required for the O<sub>2</sub> value to begin migrating back to the process value.  
Response<sub>final</sub> When the second calibration gas is turned off, note the number of seconds required for the O<sub>2</sub> value to settle out at the process value.

# Section 9 Maintenance and Service

---

Overview .....	page 9-1
Calibration with Keypad .....	page 9-1
Calibration with LOI .....	page 9-5
Oxymitter 4000 Repair .....	page 9-7

---

## OVERVIEW

This section identifies the calibration methods available and provides the procedures to maintain and service the Oxymitter 4000.

**⚠ WARNING**

Install all protective equipment covers and safety ground leads after equipment repair or service. Failure to install covers and ground leads could result in serious injury or death.

## CALIBRATION WITH KEYPAD

During a calibration, two calibration gases with known O<sub>2</sub> concentrations are applied to the Oxymitter 4000. Slope and constant values calculated from the two calibration gases determine if the Oxymitter 4000 is correctly measuring the net concentration of O<sub>2</sub> in the industrial process. A calibration record sheet has been provided on the opposite page to track performance.

Before calibrating, verify that the calibration gas parameters are correct by setting the gas concentrations used when calibrating the unit (see "Overview" in Section 5: Startup and Operation of Oxymitter 4000 with Membrane Keypad, or Section 6: Startup and Operation of Oxymitter 4000 with LOI) and by setting the calibration gas flowmeter. The calibration gas flowmeter regulates the calibration gas flow and must be set to 5 scfh. Only adjust the flowmeter to 5 scfh after placing a new diffusion element on the end of the Oxymitter 4000. Adjusting the flowmeter at any other time can pressurize the cell and bias the calibration.

In applications with a heavy dust loading, the O<sub>2</sub> probe diffusion element may become plugged over time, causing a slower speed of response. The best way to detect a plugged diffusion element is to note the time it takes the Oxymitter 4000 to return to the normal process reading after the last calibration gas is removed and the calibration gas line is blocked off. A plugged diffusion element also can be indicated by a slightly lower reading on the flowmeter.

Change the diffusion element when the calibration gas flowmeter reads slightly lower during calibration or when response to the process flue gases becomes very slow. Each time the diffusion element is changed, reset the

Figure 9-1. Membrane Keypad

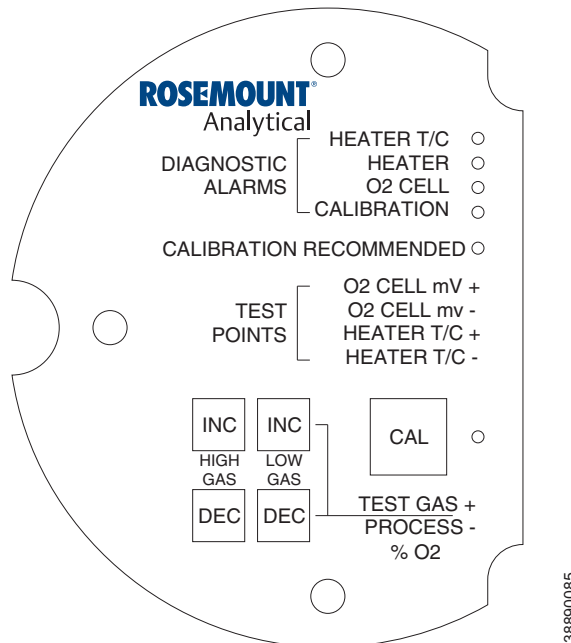

calibration gas flowmeter to 5 scfh and calibrate the Oxymitter 4000. To change the diffusion element, refer to "Ceramic Diffusion Element Replacement".

Three types of calibration methods are available: automatic, semi-automatic, and manual.

### NOTE

A calibration can be aborted any time during the process. Press the CAL key (Figure 9-1) on the Oxymitter 4000 keypad three times within three seconds, or abort via the LOI, HART/AMS, or an IMPS 4000. An aborted calibration will retain the values of the previous good calibration.

## Automatic Calibration

Automatic calibrations require no operator action. However, the calibration gases must be permanently piped to the Oxymitter 4000, an SPS 4001B or IMPS 4000 must be installed to sequence the gases, and the logic I/O must be set to mode 8 via HART/AMS so the sequencer and Oxymitter 4000 can communicate.

Depending on your system setup, an automatic calibration can be initiated by the following methods:

1. The Oxymitter 4000's CALIBRATION RECOMMENDED alarm signals that a calibration is required.
2. Enter a "time since last cal" parameter (CAL INTRVL) via HART/AMS or the LOI that will initiate an automatic calibration at a scheduled time interval (in hours). To configure the CAL INTRVL parameter, refer to "Defining a Timed Calibration via HART" in Section 7: HART/AMS, or "Navigating the Local Operator Interface" in Section 6: Startup and Operation of Oxymitter 4000 with LOI.

3. If using an IMPS 4000, enter a time interval via the IMPS 4000 keypad that will initiate an automatic calibration at a scheduled time interval (in hours). To set the CallIntvX parameter of the CHANGE PRESETS display mode, refer to the IMPS 4000 Intelligent Multiprobe Test Gas Sequencer Instruction Manual for more information.

Once an automatic calibration is initiated, by any of the methods previously described, the Oxymitter 4000's CALIBRATION RECOMMENDED alarm signals an IMPS 4000 or SPS 4001B to initiate a calibration. The sequencer sends an "in cal" signal to the control room so that any automatic control loops can be placed in manual. Then, the sequencer begins to sequence the calibration gases.

### **Semi-Automatic Calibration**

Semi-automatic calibrations only require operator initiation. However, the calibration gases must be permanently piped to the Oxymitter 4000, an SPS 4001B or IMPS 4000 must be installed to sequence the gases, and the logic I/O must be set to mode 8 or 9 via HART/AMS to allow the sequencer and the Oxymitter 4000 to communicate.

Depending on your system setup, a semi-automatic calibration can be initiated by the following methods:

1. Oxymitter 4000 with membrane keypad. Press the CAL key on the Oxymitter 4000 keypad.
2. Oxymitter 4000 with LOI. Select "Start Calib" from the CALIBRATION menu.
3. IMPS 4000. Use the IMPS 4000 keypad to change the InitCalX parameter of the CHANGE PRESETS display mode from 0000 to 0001. Refer to the IMPS 4000 Intelligent Multiprobe Test Gas Sequencer Instruction Manual for more information.
4. HART. Use the HART Communicator to access the O<sub>2</sub> CALIBRATE menu and perform the O<sub>2</sub> CAL method. Refer to "HART Communicator O<sub>2</sub> Cal Method" in Section 7: HART/AMS for the complete calibration procedure.
5. AMS. Refer to AMS documentation for more information.
6. Remote Contact. Initiate a calibration from a remote location via the remote contact input connection provided by an IMPS 4000 or SPS 4001B. Refer to the documentation available for the control system in use for more information.

Once a semi-automatic calibration is initiated by any of the methods previously described, the Oxymitter 4000's CALIBRATION RECOMMENDED alarm signals an IMPS 4000 or SPS 4001B to initiate a calibration. The sequencer sends an "in cal" signal to the control room so that any automatic control loops can be placed in manual. Then, the sequencer begins to sequence the calibration gases.

### **Manual Calibration with Membrane Keypad**

Manual calibrations must be performed at the Oxymitter 4000 site and will require operator intervention throughout the process. Manual calibration instructions, in condensed form, can also be found on the inside of the right electronics housing cover. See Figure 9-2.

Use the following procedure to perform a manual calibration:

1. Place control loop in manual.

Figure 9-2. Inside Right Cover

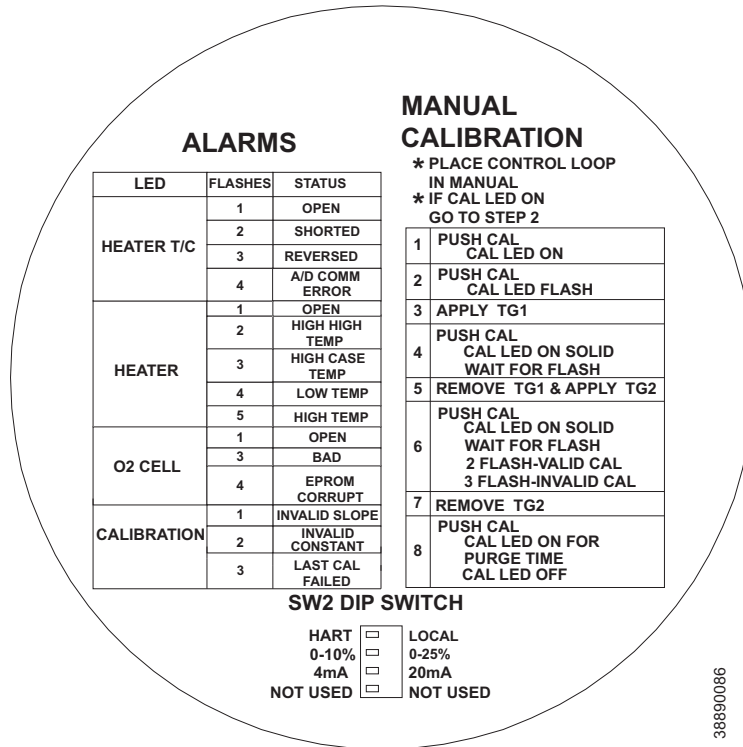

2. Verify the calibration gas parameters are correct per "Calibration with Keypad".
3. If performing a manual calibration with the CALIBRATION RECOMMENDED LED off and the CAL LED off, start at step a.
4. If performing a manual calibration with the CALIBRATION RECOMMENDED LED on and the CAL LED on, start at step b.
  - a. Push the CAL key. The CALIBRATION RECOMMENDED LED will come on and the CAL LED will be on solid. If a multimeter is attached across TP5 and TP6, the reading will display the percentage of oxygen seen by the cell.
  - b. Push the CAL key. The CALIBRATION RECOMMENDED LED will turn off and the CAL LED will flash continuously. The Oxymitter 4000 can be configured so that the 4-20 mA signal will hold the last value. The default condition is for the output to track. A flashing LED indicates that the Oxymitter 4000 is ready to accept the first calibration gas.
  - c. Apply the first calibration gas. (Electronics will abort the calibration if step 4 is not done within 30 minutes).
  - d. Push the CAL key; the CAL LED will be on solid. A timer is activated to allow the calibration gas adequate time to flow (default time of five minutes). When the timer times out, the Oxymitter 4000 has taken the readings using the first calibration gas and the CAL LED will flash continuously. The flashing indicates the Oxymitter 4000 is ready to take readings using the second calibration gas.



- e. Remove the first calibration gas and apply the second calibration gas. (Electronics will abort the calibration if step f is not done within 30 minutes).
- f. Push the CAL key; the CAL LED will be on solid. The timer is activated for the second calibration gas flow. When the timer times out, the CAL LED will flash a 2 pattern flash or a 3 pattern flash (2 pattern flash equals a valid calibration, 3 pattern flash equals an invalid calibration). If the slope or the constant is out of specification, a diagnostic alarm LED will be flashing. The diagnostic alarm will remain active until the purge cycle is over. If the three pattern flash occurs without a diagnostic alarm, the calibration gases could be the same or the calibration gas was not turned on.

A flashing CAL LED indicates the calibration is done. (See Section 8: Troubleshooting, for an explanation of the 2 pattern and 3 pattern flashes).

- g. Remove the second calibration gas and cap off the calibration gas port.
- h. Push the CAL key; the CAL LED will be on solid as the unit purges. (Default purge time is three minutes). When the purge is complete, the CAL LED will turn off and the Oxymitter 4000 output unlocks from its held value and begins to read the process O<sub>2</sub>.

If the calibration was valid, the DIAGNOSTIC ALARMS LEDs will indicate normal operation. If either new calibration value (slope or constant) is not within parameters, the DIAGNOSTIC ALARMS LED will indicate an alarm. (See Section 8: Troubleshooting, for alarm codes). If the calibration was invalid, the Oxymitter 4000 will return to normal operation, as it was before a calibration was initiated, and the parameters will not be updated.

- 5. Place control loop in automatic.

**CALIBRATION WITH LOI**

Refer to Figure 6-4 for a view of the LOI menu tree. To calibrate the Oxymitter 4000 from the LOI, access the CALIBRATION/ Start Calibration menu.

**CALIBRATION/Start Calibration**

This is the starting point for calibrations. The LOI will instruct the user through this entire procedure. Select "Abort Calib" at any time to abort the calibration.

- 1. The LOI displays the following:

**Apply Gas 1**  
**Hit E when ready**

The Oxymitter 4000 is ready to accept the first calibration gas. Apply the first calibration gas. (Electronics will abort the calibration if this step is not done within 30 minutes).

- 2. Touch the Enter key to start the Gas 1 flow. A timer is activated to allow the calibration gas adequate time to flow (default time of five minutes). The LOI displays:

**Flow Gas 1 xxxxs**  
**Read Gas 1 xxxxs**  
**Done Gas 1**

The display counts down the seconds remaining to flow Gas 1, then the time remaining for sensing the O<sub>2</sub> concentration of Gas 1. Done Gas 1 indicates completion.

3. Remove the first calibration gas and apply the second calibration gas. (Electronics will abort the calibration if this step is not done within 30 minutes). The LOI displays the following:

**Apply Gas 2**  
**Hit E when ready**

4. Touch the Enter arrow to start the Gas 2 flow. The timer is activated and the LOI displays:

**Flow Gas 2 xxxxs**  
**Read Gas 2 xxxxs**  
**Done Gas 2**  
**Stop Gas**  
**Hit E when ready**

5. Remove the second calibration gas and cap off the calibration gas port. Then, touch the Enter arrow to indicate completion. The timer is activated and the LOI displays:

**Purge xxxxs**

The default purge time is three minutes. When the gas purge timer times out, the Oxymitter 4000 begins to read the process O<sub>2</sub>.

### **Abort Calibration**

Exits the calibration. After calibration gases are removed, and the purge times out, the instrument goes back to normal operational mode.

### **Cal Constants - Results of the Calibration**

#### **Current calibration**

If the calibration passed these values will be updated. Log these values onto the calibration log sheet supplied. If the process has high levels of particulate, the response back to the process after cal gas is also removed.

#### **Previous Calibration**

Values from the prior good calibration.

#### **Failed Calibration**

Bad calibration values are not loaded into the electronics.

### **Calibration Status**

#### **Calibration Step**

The current step in an active calibration procedure.

#### **Calibration Time**

Time until the next scheduled calibration.

#### **Next O<sub>2</sub> Cal**

Time until the next O<sub>2</sub> calibration, if different than the next scheduled calibration.

**OXYMITTER 4000  
REPAIR**

Each of the following procedures details how to remove and replace a specific component of the Oxymitter 4000.

**⚠ WARNING**

It is recommended that the Oxymitter 4000 be removed from the stack for all service activities. The unit should be allowed to cool and be taken to a clean work area. Failure to comply may cause severe burns.

**⚠ WARNING**

Disconnect and lock out power before working on any electrical components. There is voltage up to 115 VAC.

**Removal and  
Replacement of Probe**

1. Remove.
  - a. Turn off power to the system.
  - b. Shut off the calibration gases at the cylinders and the instrument air.
  - c. Disconnect the calibration gas and instrument air lines from the Oxymitter 4000.
  - d. Remove left housing cover (27, Figure 9-3 or Figure 9-4).
  - e. Remove all signal and power wiring to the probe.
  - f. Remove insulation to access the mounting bolts.
  - g. Unbolt the Oxymitter 4000 from the stack and take it to a clean work area.
  - h. Allow the unit to cool to a comfortable working temperature.
2. Replace.
  - a. Bolt the Oxymitter 4000 to the stack and install the insulation.
  - b. Connect all signal and power leads at the probe. Refer to Section 3: Installation, for detailed wiring instructions.
  - c. Connect the calibration gas and instrument air lines to probe.
  - d. Instal left housing cover (27, Figure 9-3 or Figure 9-4).
  - e. Turn on instrument air.
  - f. Restore power to the system; refer to "Power Up" in Section 5: Startup and Operation of Oxymitter 4000 with Membrane Keypad or "Power Up" in Section 6: Startup and Operation of Oxymitter 4000 with LOI. When the probe is at operating temperature, calibrate the probe per "Calibration with Keypad".

**NOTE**

Recalibration is required whenever electronic cards or sensing cell is replaced.

# Oxymitter 4000

Figure 9-3. Oxymitter 4000 with Integral Electronics - Exploded View

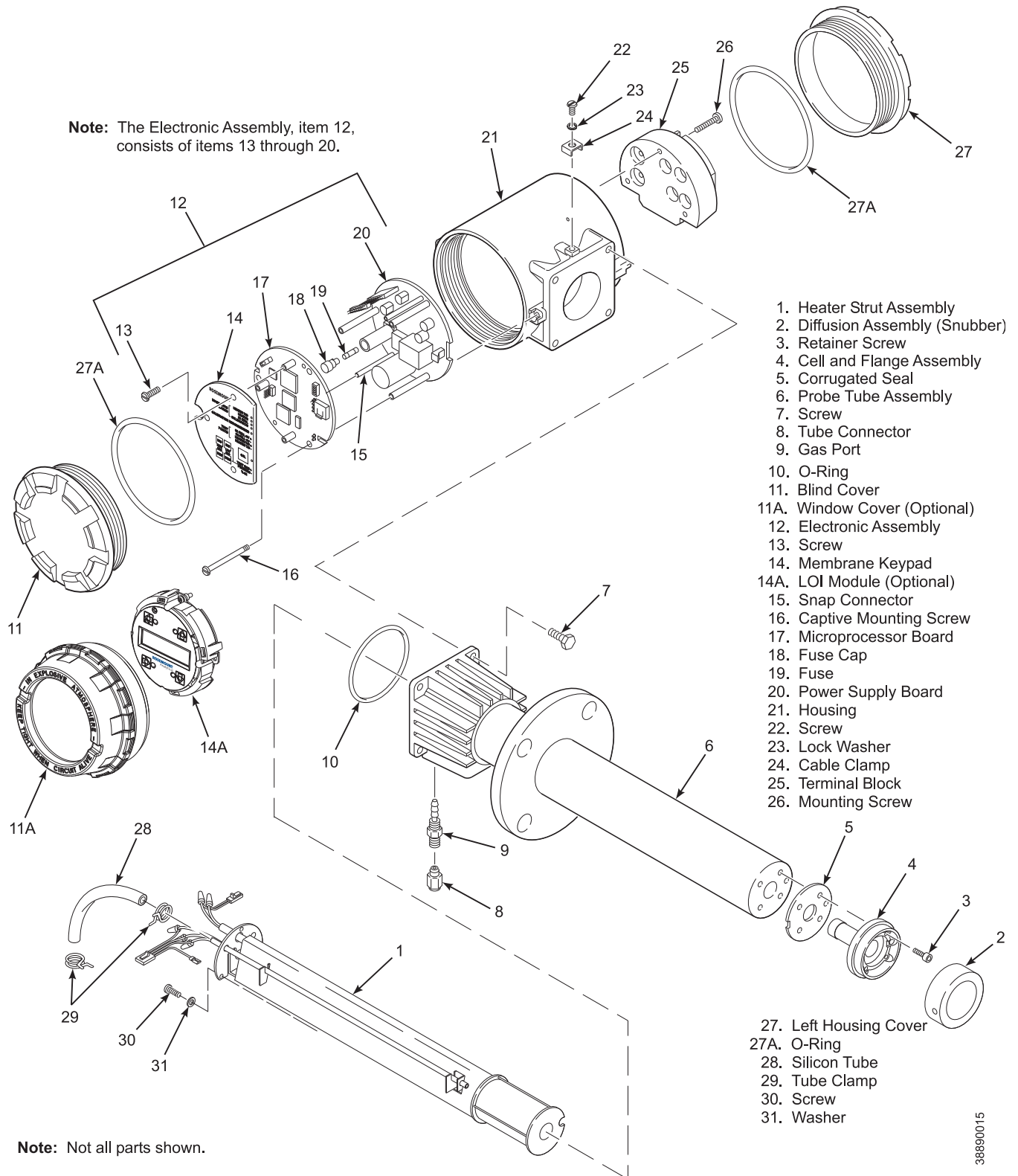

38890015

# Instruction Manual

IM-106-340, Rev. 4.2

July 2008

# Oxymitter 4000

Figure 9-4. Oxymitter 4000 with Remote Electronics - Exploded View

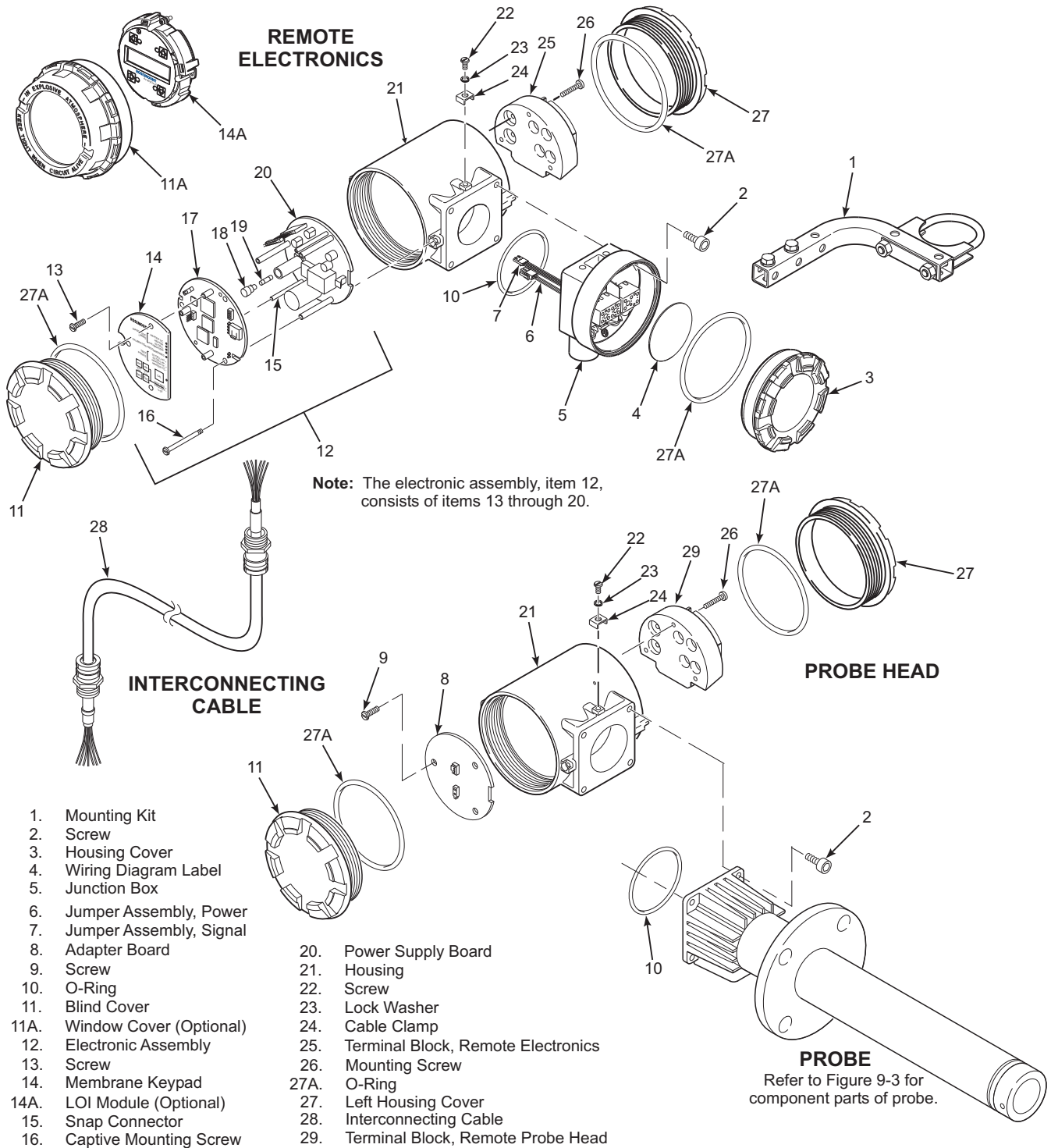

38890034

---

## Replace Entire Integral Electronics (with Housing)

---

**NOTE**

Only perform this procedure on units with integral electronics.

---

**NOTE**

Recalibration is required whenever electronic cards or sensing cell is replaced.

---

1. Follow the instructions in "Removal and Replacement of Probe", to remove the Oxymitter 4000 from the stack or duct.
2. Remove the right housing cover uncovering the electronic assembly (Figure 9-5).
3. Depress and remove the J1 (cell and T/C) connector from the J1 socket. Loosen the three captive mounting screws (16, Figure 9-3 or Figure 9-4) on the microprocessor board (top board).
4. The J8 connector (heater leads) (Figure 9-6) can be accessed by moving the J1 connector leads out of the slot on the microprocessor board (17) and sliding the electronic assembly (12) partially out of the housing (Figure 9-3 or Figure 9-4).
5. Squeeze the J8 connector on the sides and carefully remove. The electronic assembly can now be completely removed from the housing.
6. Remove four screws (7, Figure 9-3) from the probe finned housing. The probe and the electronic housing can now be separated.
7. When reinstalling or replacing the electronic housing, make sure that O-ring (10) is in good condition. Place the J1 and J8 connectors in the hole on the flat side of the electronic housing.
8. Hold the J1 and J8 connectors out and to the probe side of the electronic housing. Make sure that the conduit port of the electronic housing is on the same side as the CAL and REF gas ports. Replace the four screws and tighten.
9. Reconnect the J8 connector to the power supply board. Make sure the connector is secure.
10. Holding the J1 connector leads, slide the electronic assembly the rest of the way into the housing. Align the electronic assembly so that it fits flush on the pins. To ensure that it is flush, gently try to rotate the electronics. If the electronics rotates, repeat the alignment.
11. Reconnect the J1 connector to the microprocessor board. Ensure the connector is secure and tighten the three captive screws on the microprocessor board (top board).
12. Replace the housing cover and ensure it is tight.
13. Follow the instructions in "Removal and Replacement of Probe" to install the Oxymitter 4000 into the stack or duct.

# Instruction Manual

IM-106-340, Rev. 4.2

July 2008

# Oxymitter 4000

Figure 9-5. Electronic Assembly

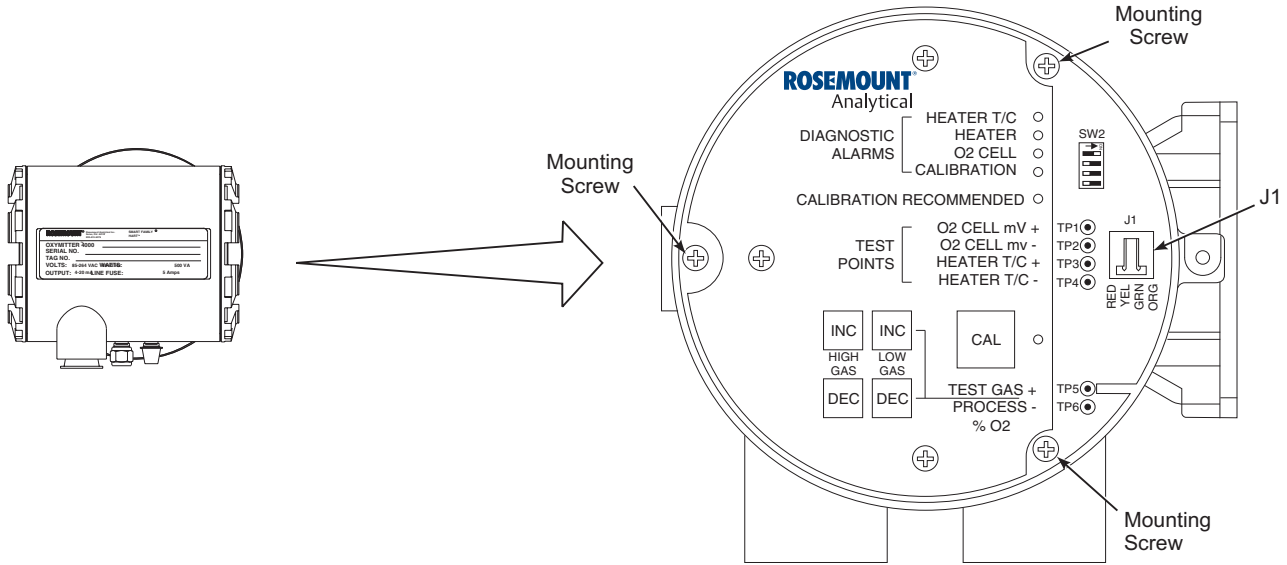
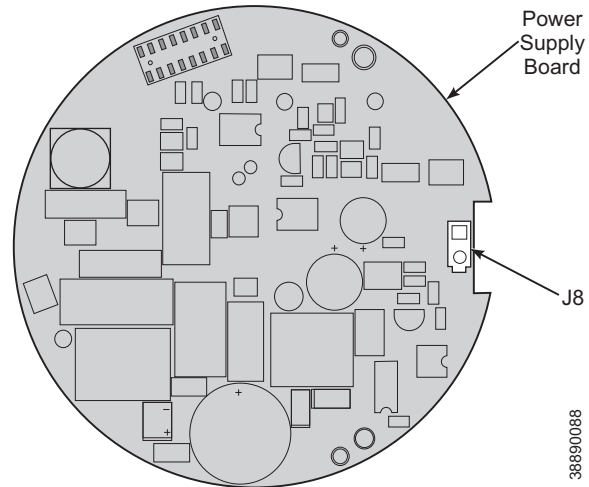

Figure 9-6. J8 Connector



## **Electronic Assembly Replacement**

(Figure 9-5)

1. Remove the right housing cover uncovering the electronic assembly.
2. Depress and remove the J1 (cell and T/C) connector from the J1 socket. Loosen the three captive mounting screws (16, Figure 9-3 or Figure 9-4) on the microprocessor board (top board).
3. The J8 connector (heater leads) can be accessed by moving the J1 connector leads out of the slot on microprocessor board (17) and sliding the electronic assembly (12) partially out of the housing (Figure 9-6).
4. Squeeze the J8 connector on the sides and carefully remove. The electronic assembly can now be completely removed from the housing.
5. Reconnect the J8 connector to the power supply board. Make sure the connector is secure.
6. Holding the J1 connector leads, slide the electronic assembly the rest of the way into the housing. Align the electronic assembly so that it fits flush on the pins. To ensure that it is flush, gently try to rotate the electronics. If the electronics rotates, repeat the alignment.
7. Reconnect the J1 connector to the microprocessor board. Ensure the connector is secure and tighten the three captive mounting screws on the microprocessor board (top board).
8. Replace the housing cover and ensure it is tight.

## **Terminal Block Replacement**

1. Unscrew left housing cover (27, Figure 9-3).
2. Loosen mounting screws (26) on terminal block (25) and carefully lift the block out of the housing.
3. Carefully align the new terminal block on the pins so that it sits flat in the housing. The round end of the terminal block should be on the opposite side of the housing conduit ports and should not be able to rotate.
4. Tighten the three mounting screws and ensure the terminal block is secure in the housing.

## **Fuse Replacement**

(Figure 9-7)

1. Remove the right housing cover uncovering the electronic assembly.
2. Depress and remove the J1 (cell and T/C) connector from the J1 socket. Loosen the three captive mounting screws (16, Figure 9-3 or Figure 9-4) on the microprocessor board (top board).
3. The J8 connector (heater leads) (Figure 9-6) can be accessed by moving the J1 connector leads out of the slot on the microprocessor board (17, Figure 9-3 or Figure 9-4) and sliding the electronic assembly (12) partially out of the housing.
4. Squeeze the J8 connector on the sides and carefully remove. The electronic assembly can now be completely removed from the housing.
5. Completely remove the three mounting screws (16) on the microprocessor board (17).



Figure 9-7. Fuse Location

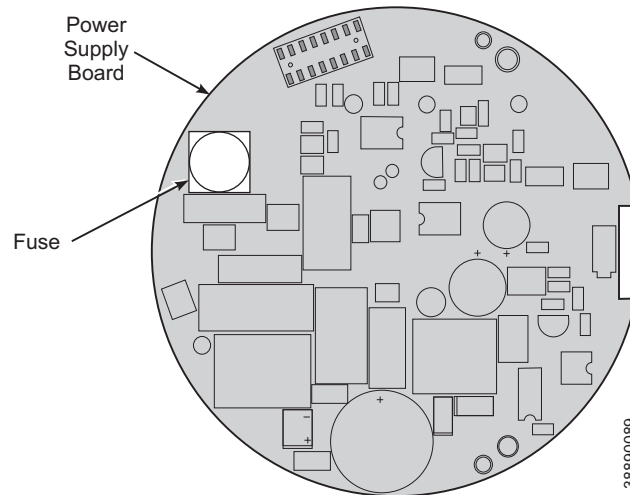

6. Turn the electronic assembly over so that you are looking at the bottom of the power supply printed circuit board. Gently depress the two white posts one at a time. Carefully separate the power supply board (20) from the microprocessor board (17).
7. Remove fuse (19) and replace it with a new one (Figure 9-7).
8. Align the white posts with the post holes on the power supply board and the pin connector on the power supply board with the connector port on the back of the microprocessor board. Gently push the boards together until the white posts snap in place. Ensure the assembly is secure by gently trying to separate the boards.
9. Reconnect connector J8 to the power supply board. Make sure the connector is secure.
10. Holding the J1 connector leads, slide the electronic assembly the rest of the way into the housing. Align the electronic assembly so that it fits flush on the pins. To ensure that it is flush, gently try to rotate the electronics. If the electronics rotates, repeat the alignment.
11. Reconnect the J1 connector to the microprocessor board. Ensure the connector is secure and tighten the three captive screws on the microprocessor board (top board).
12. Replace the housing cover and ensure that it is tight.

**Entire Probe Replacement (Excluding Probe Head)**

1. Do not attempt to replace the probe until all other possibilities for poor performance have been considered. If probe replacement is needed, see Table 10-1 for part numbers.
2. Follow the instructions in "Removal and Replacement of Probe" to remove the Oxymitter 4000 from the stack or duct.
3. Separate the probe and the probe head per "Replace Entire Integral Electronics (with Housing)", steps 2 through 6.
4. Reinstall the probe head on the new probe per "Replace Entire Integral Electronics (with Housing)", steps 7 through 13.

### Heater Strut Replacement

This paragraph covers heater strut replacement. Do not attempt to replace the heater strut until all other possibilities for poor performance have been considered. If heater strut replacement is needed, order a replacement heater strut (Table 10-1). Refer to Figure 9-3 or Figure 9-4 to view the component parts of the Oxymitter 4000.

#### **WARNING**

Use heat resistant gloves and clothing when removing probe. Do not attempt to work on the probe until it has cooled to room temperature. The probe can be as hot as 800°F (427°C). This can cause severe burns.

1. Follow the instructions in "Removal and Replacement of Probe" to remove the Oxymitter 4000 from the stack or duct.
2. For a unit with integral electronics, disconnect electronics per "Replace Entire Integral Electronics (with Housing)", steps 2 through 5.
3. For a unit with remote electronics, remove cover (11, Figure 9-4) from housing (21) along with adapter board (8) and screw (9) from heater strut assembly (1, Figure 9-3).
4. Remove four screws (2, Figure 9-4). Remove the probe from housing (21).
5. Remove tube clamps (29, Figure 9-3) and silicon tubes (28, Figure 9-3) from the CAL and REF gas ports and the CAL and REF gas lines.
6. Loosen, but do not remove, three screws (30, Figure 9-3). The spring tension will release and the heater strut assembly should move up.
7. When the spring tension is released, remove three screws (30). Grasp the wire loop and carefully slide the heater strut assembly (Figure 9-8) out of the probe tube.
8. When replacing the strut, orient the probe so the small calibration gas tube is at the 6 o'clock position of the probe tube. Align the slot on the heater plate with the calibration gas line in the probe tube. Slide the strut into the probe tube. It will turn to align the hole on the back plate of the strut with the calibration gas line. When the hole and the calibration gas line are aligned correctly, the strut will slide in the rest of the way.
9. As the strut installation nears completion, install the guide rod into the calibration gas tube to assist in guiding the calibration gas tube through the hole in the end of the strut.
10. Push down on the back plate of the strut to make sure you have spring tension and then tighten the three screws on the back plate.
11. Replace the CAL and REF gas silicon tubes.
12. For units with integral electronics, install the entire electronics per "Replace Entire Integral Electronics (with Housing)", steps 7 through 13.

Figure 9-8. Heater Strut Assembly

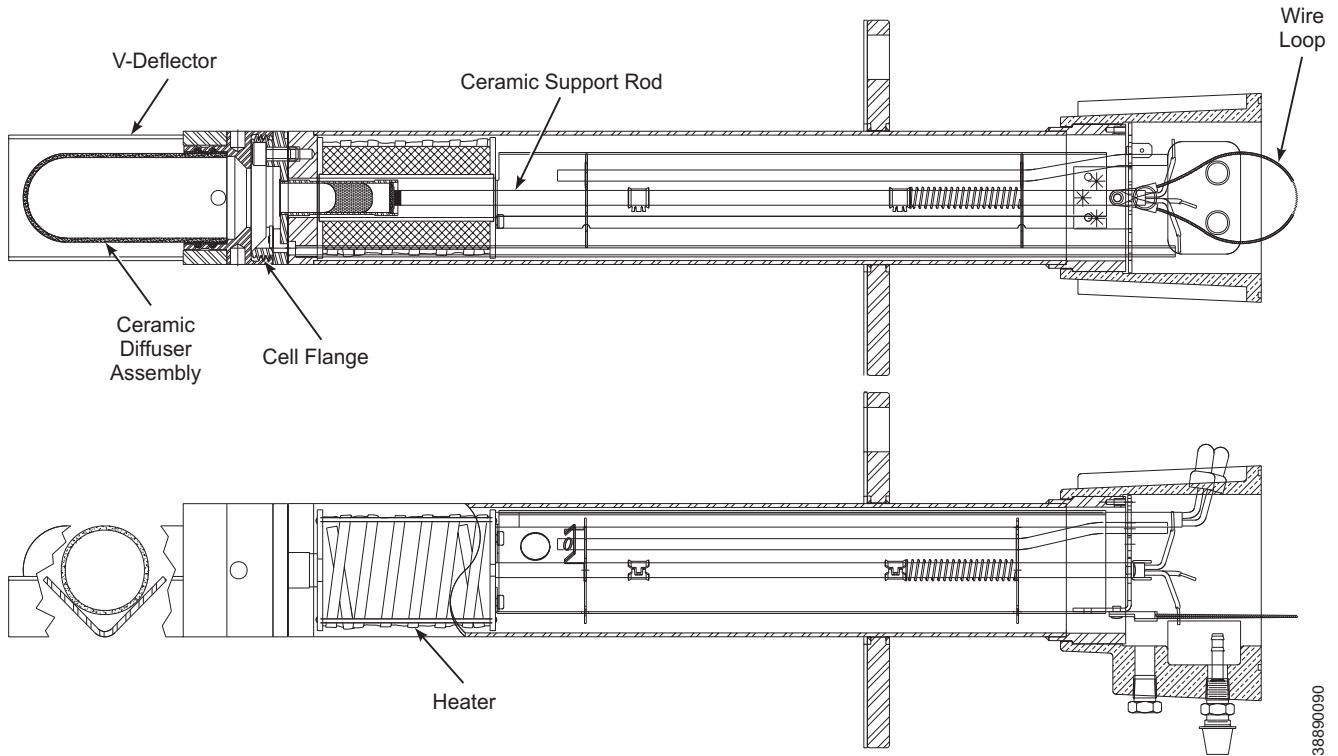

13. For units with remote electronics, install the probe head as follows:
  - a. See Figure 9-9. Make sure that the O-ring is in good condition. Seat the O-ring in the mating groove of the probe.
  - b. Insert the probe signal cables into the housing.
  - c. Turn the conduit ports of the housing to the CAL and REF gas ports side of the probe and position the housing on the probe.
  - d. Install and tighten four screws (2, Figure 9-4).
  - e. Reconnect the probe signal cables to the probe signal and heater wire connectors, Figure 9-9. Make sure the connectors are secure.
  - f. Install and tighten cover.
14. Follow the instructions in "Removal and Replacement of Probe" to install the Oxymitter 4000 into the stack or duct.

Figure 9-9. Probe to Probe Head Assembly - Remote Electronics Only

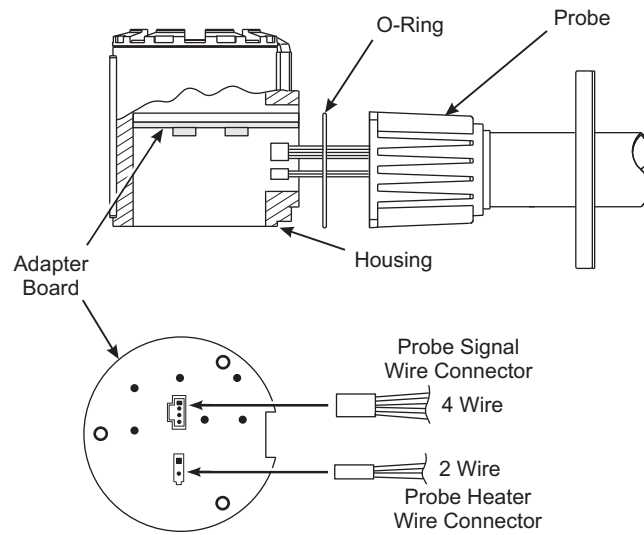

38890058

### Cell Replacement

This paragraph covers oxygen sensing cell replacement. Do not attempt to replace the cell until all other possibilities for poor performance have been considered. If cell replacement is needed, order the cell replacement kit (Table 10-1). Refer to Figure 9-3 or Figure 9-4 to view the component parts of the Oxymitter 4000.

The cell replacement kit (Figure 9-10) contains a cell and flange assembly, corrugated seal, setscrews, socket head cap screws, and anti-seize compound. The items are carefully packaged to preserve precise surface finishes. Do not remove items from the packaging until they are ready to be used. Spanner wrenches and hex wrenches needed for this procedure are part of an available special tools kit (Table 10-1 and Figure 10-2).

Figure 9-10. Cell Replacement Kit

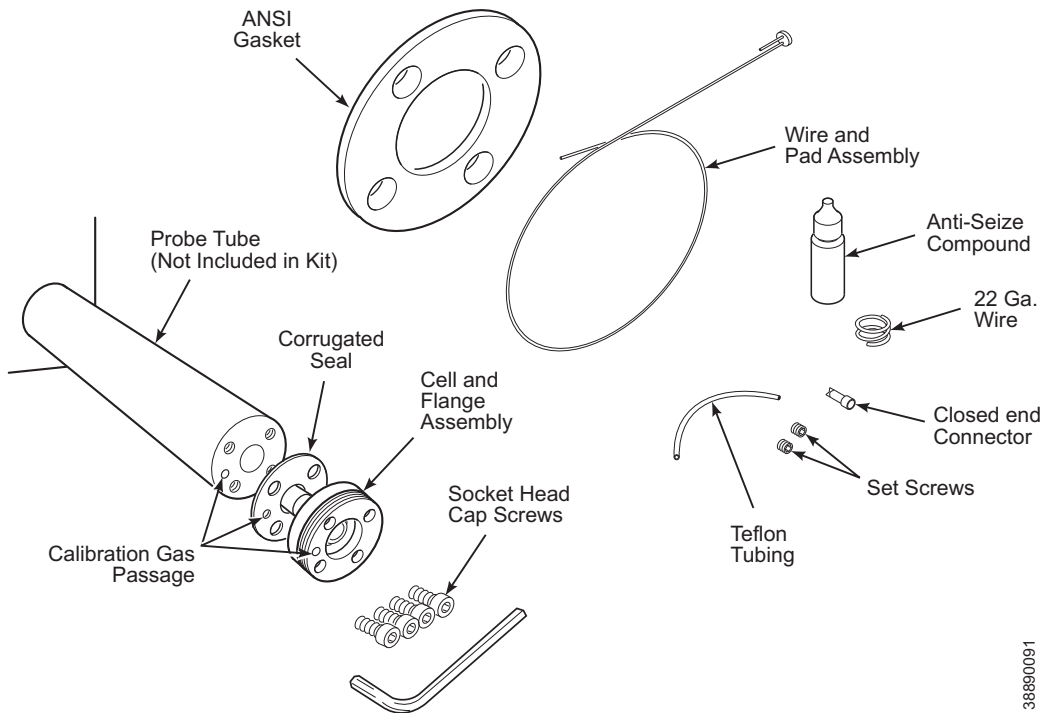

38890091

**⚠ WARNING**

Use heat-resistant gloves and clothing when removing the probe. Do not attempt to work on these components until they have cooled to room temperature. Probe components can be as hot as 572°F (300°C). This can cause severe burns.

Disconnect and lock out power before working on any electrical components. There is voltage of up to 115 VAC.

**⚠ CAUTION**

Do not remove the cell unless certain it needs to be replaced. Removal may damage the cell and platinum pad. Go through the complete troubleshooting procedure to make sure the cell needs to be replaced before removing it.

1. Follow the instructions in "Removal and Replacement of Probe" to remove the Oxymitter 4000 from the stack or duct.

**NOTE**

To determine if the diffuser needs to be replaced, refer to "Calibration with Keypad".

2. If the probe uses the standard diffusion element, use a spanner wrench to remove the diffuser assembly.

3. If equipped with the optional ceramic diffusion assembly, remove and discard the setscrews and remove the vee deflector (Figure 9-11). Use spanner wrenches from the probe disassembly kit (Table 10-1 and Figure 10-2), to turn the hub free from the retainer. Inspect the diffusion element. If damaged, replace the element.
4. Loosen the four socket head cap screws from the cell and flange assembly and remove the assembly and the corrugated seal. The cell flange has a notch that may be used to gently pry the flange away from the probe. Note that the contact pad inside of the probe will sometimes fuse to the oxygen sensing cell. If the cell is fused to the contact pad, push the cell assembly back into the probe (against spring pressure) and quickly twist the cell assembly. The cell and contact pad should separate. If the contact pad stays fused to the cell, a new contact/thermocouple assembly must be installed. Disconnect the cell and the thermocouple wires at the crimp connections and withdraw the cell with the wires still attached.
5. For units with integral electronics, disconnect the entire electronics per "Replace Entire Integral Electronics (with Housing)", steps 2 through 5.
6. Remove four screws (7, Figure 9-3) from the probe finned housing. The probe and the probe head can now be separated.
7. If the contact assembly is damaged, replace the strut or the contact pad. Instructions for replacing the contact pad are in the cell replacement kit.
8. Remove and discard the corrugated seal. Clean the mating faces of the probe tube and retainer. Remove burrs and raised surfaces with a block of wood and crocus cloth. Clean the threads on the retainer and hub.
9. Rub a small amount of anti-seize compound on both sides of the new corrugated seal.
10. Assemble the cell and flange assembly, corrugated seal, and probe tube. Make sure the calibration tube lines up with the calibration gas passage in each component. Apply a small amount of anti-seize compound to the screw threads and use the screws to secure assembly. Torque to 35 in-lbs (4 N·m).
11. Install the entire electronics per "Replace Entire Integral Electronics (with Housing)", steps 7 through 13.
12. Apply anti-seize compound to the threads of the cell assembly, hub, and setscrews. Reinstall the hub on the cell assembly. Using pin spanner wrenches, torque to 10 ft-lbs (14 N·m). If applicable, reinstall the vee deflector, orienting apex toward gas flow. Secure with the setscrews and anti-seize compound. Torque to 25 in-lbs (2.8 N·m).
13. On systems equipped with an abrasive shield, install the dust seal gaskets, with joints 180° apart.
14. Reinstall the probe and gasket on the stack flange.
15. Follow the instructions in "Removal and Replacement of Probe" to install the Oxymitter 4000 into the stack or duct. If there is an abrasive shield in the stack, make sure the dust seal gaskets are in place as they enter the 15° reducing cone.
16. Turn on power and monitor thermocouple output. It should stabilize at 29.3±0.2 mV. Set reference air flow at 1 l/min (2 scfh). After the Oxymitter 4000 stabilizes, calibrate the unit. If new components have been installed, repeat calibration after 24 hours of operation.

**Ceramic Diffusion Element Replacement**

**NOTE**

This refers to the ceramic diffusion element only.

**General**

The diffusion element protects the cell from particles in process gases. Normally, it does not need to be replaced because the vee deflector protects it from particulate erosion.

In severe environments, the filter may be broken or subject to excessive erosion. Examine the ceramic diffusion element whenever removing the probe for any purpose. Replace if damaged.

Damage to the ceramic diffusion element may become apparent during calibration. Compare probe response with previous response. A broken diffusion element will cause a slower response to calibration gas. Hex wrenches needed to remove setscrews and socket head screws in the following procedure are available as part of a Probe Disassembly Kit, Table 10-1.

**Replacement Procedure**

- a. Follow the instructions in "Removal and Replacement of Probe" to remove the Oxymitter 4000 from the stack or duct.
- b. Loosen setscrews, Figure 9-11, using hex wrench from Probe Disassembly Kit, Table 10-1, and remove vee deflector. Inspect setscrews. If damaged, replace with stainless setscrews coated with anti-seize compound.

Figure 9-11. Ceramic Diffuser Element Replacement

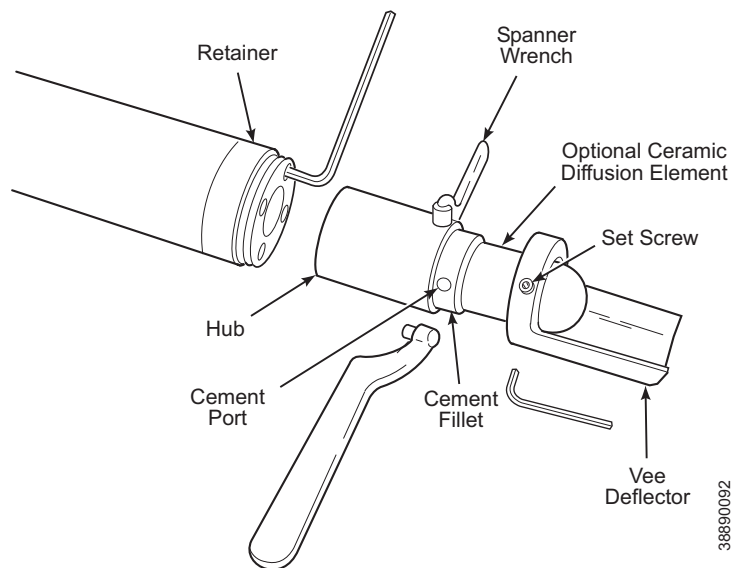
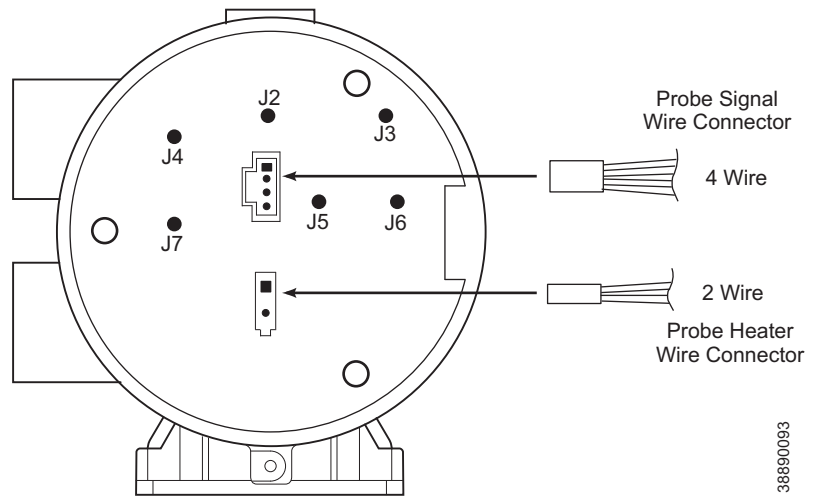

Figure 9-12. Contact and Thermocouple Assembly Replacement



### Termination Housing Wiring (Remote Electronics Probe Head Only)

Under normal circumstances, the right termination housing cover should not need to be removed. This side of the housing contains the probe signal wire connector and the probe heater wire connector that plug into the adapter board. If these wires should become disconnected or need to be replaced, use the diagram in Figure 9-12 to reconnect the wires.



# Section 10 Replacement Parts

---

Probe Replacement Parts .....	page 10-1
Electronics Replacement Parts .....	page 10-6

---

## PROBE REPLACEMENT PARTS

Table 10-1. Replacement Parts for Probe

Figure and Index Number	Part Number		Description
	No Dust Seal	With Dust Seal	
9-3, 1 thru 6, 8,9,28 thru 31	3D39648G01	3D39649G01	18" ANSI Probe with Ceramic Diffuser
9-3, 1 thru 6, 8,9,28 thru 31	3D39648G02	3D39649G02	3' ANSI Probe with Ceramic Diffuser
9-3, 1 thru 6, 8,9,28 thru 31	3D39648G03	3D39649G03	6' ANSI Probe with Ceramic Diffuser
9-3, 1 thru 6, 8,9,28 thru 31	3D39648G04	3D39649G04	9' ANSI Probe with Ceramic Diffuser
9-3, 1 thru 6, 8,9,28 thru 31	3D39648G05	3D39649G05	12' ANSI Probe with Ceramic Diffuser
9-3, 1 thru 6, 8,9,28 thru 31	--	3D39649G53	15' ANSI Probe with Ceramic Diffuser
9-3, 1 thru 6, 8,9,28 thru 31	--	3D39649G54	18' ANSI Probe with Ceramic Diffuser
9-3, 1 thru 6, 8,9,28 thru 31	3D39648G11	3D39649G11	18" DIN Probe with Ceramic Diffuser
9-3, 1 thru 6, 8,9,28 thru 31	3D39648G12	3D39649G12	3' DIN Probe with Ceramic Diffuser
9-3, 1 thru 6, 8,9,28 thru 31	3D39648G13	3D39649G13	6' DIN Probe with Ceramic Diffuser
9-3, 1 thru 6, 8,9,28 thru 31	3D39648G14	3D39649G14	9' DIN Probe with Ceramic Diffuser
9-3, 1 thru 6, 8,9,28 thru 31	3D39648G15	3D39649G15	12' DIN Probe with Ceramic Diffuser
9-3, 1 thru 6, 8,9,28 thru 31	3D39648G17	3D39648G17	18" ANSI Probe with Flame Arrestor and Ceramic Diffuser
9-3, 1 thru 6, 8,9,28 thru 31	3D39648G18	3D39648G18	3' ANSI Probe with Flame Arrestor and Ceramic Diffuser
9-3, 1 thru 6, 8,9,28 thru 31	3D39648G19	3D39648G19	6' ANSI Probe with Flame Arrestor and Ceramic Diffuser
9-3, 1 thru 6, 8,9,28 thru 31	3D39648G20	3D39648G20	9' ANSI Probe with Flame Arrestor and Ceramic Diffuser
9-3, 1 thru 6, 8,9,28 thru 31	3D39648G21	3D39648G21	12' ANSI Probe with Flame Arrestor and Ceramic Diffuser
9-3, 1 thru 6, 8,9,28 thru 31	--	3D39649G55	15' ANSI Probe with Flame Arrestor and Ceramic Diffuser
9-3, 1 thru 6, 8,9,28 thru 31	--	3D39649G56	18' ANSI Probe with Flame Arrestor and Ceramic Diffuser

# Oxymitter 4000

Table 10-1. Replacement Parts for Probe (Continued)

Figure and Index Number	Part Number		Description
9-3, 1 thru 6, 8,9,28 thru 31	3D39648G27	3D39649G27	18" DIN Probe with Flame Arrestor and Snubber Diffuser
9-3, 1 thru 6, 8,9,28 thru 31	3D39648G28	3D39649G28	3' DIN Probe with Flame Arrestor and Snubber Diffuser
9-3, 1 thru 6, 8,9,28 thru 31	3D39648G29	3D39649G29	6' DIN Probe with Flame Arrestor and Snubber Diffuser
9-3, 1 thru 6, 8,9,28 thru 31	3D39648G30	3D39649G30	9' DIN Probe with Flame Arrestor and Snubber Diffuser
9-3, 1 thru 6, 8,9,28 thru 31	3D39648G31	3D39649G31	12' DIN Probe with Flame Arrestor and Snubber Diffuser
9-3, 1 thru 6, 8,9,28 thru 31	3D39648G33	3D39649G33	18" ANSI Probe with Snubber Diffuser
9-3, 1 thru 6, 8,9,28 thru 31	3D39648G34	3D39649G34	3' ANSI Probe with Snubber Diffuser
9-3, 1 thru 6, 8,9,28 thru 31	3D39648G35	3D39649G35	6' ANSI Probe with Snubber Diffuser
9-3, 1 thru 6, 8,9,28 thru 31	3D39648G36	3D39649G36	9' ANSI Probe with Snubber Diffuser
9-3, 1 thru 6, 8,9,28 thru 31	3D39648G37	3D39649G37	12' ANSI Probe with Snubber Diffuser
9-3, 1 thru 6, 8,9,28 thru 31	--	3D39649G49	15' ANSI Probe with Snubber Diffuser
9-3, 1 thru 6, 8,9,28 thru 31	--	3D39649G50	18' ANSI Probe with Snubber Diffuser
9-3, 1 thru 6, 8,9,28 thru 31	3D39648G43	3D39649G43	18" DIN Probe with Snubber Diffuser
9-3, 1 thru 6, 8,9,28 thru 31	3D39648G44	3D39649G44	3' DIN Probe with Snubber Diffuser
9-3, 1 thru 6, 8,9,28 thru 31	3D39648G45	3D39649G45	6' DIN Probe with Snubber Diffuser
9-3, 1 thru 6, 8,9,28 thru 31	3D39648G46	3D39649G46	9' DIN Probe with Snubber Diffuser
9-3, 1 thru 6, 8,9,28 thru 31	3D39648G47	3D39649G47	12' DIN Probe with Snubber Diffuser
9-3, 6	3D39644G01		18" ANSI Probe Tube Assy.
9-3, 6	3D39644G02		3' ANSI Probe Tube Assy.
9-3, 6	3D39644G03		6' ANSI Probe Tube Assy.
9-3, 6	3D39644G04		9' ANSI Probe Tube Assy.
9-3, 6	3D39644G05		12' ANSI Probe Tube Assy.
9-3, 6	3D39644G17		15' ANSI Probe Tube Assy.
9-3, 6	3D39644G18		18' ANSI Probe Tube Assy.
9-3, 6	3D39644G11		18" DIN Probe Tube Assy.
9-3, 6	3D39644G12		3' DIN Probe Tube Assy.
9-3, 6	3D39644G13		6' DIN Probe Tube Assy.
9-3, 6	3D39644G14		9' DIN Probe Tube Assy.
9-3, 6	3D39644G15		12' DIN Probe Tube Assy.
9-3, 6	3D39645G01		18" Heater Strut Assy.
9-3, 1	3D39645G02		3' Heater Strut Assy.
9-3, 1	3D39645G03		6' Heater Strut Assy.
9-3, 1	3D39645G04		9' Heater Strut Assy.
9-3, 1	3D39645G05		12' Heater Strut Assy.
9-3, 1	3D39645G07		15' Heater Strut Assy.
9-3, 1	3D39645G08		18' Heater Strut Assy.

Figure 10-1. Cell Replacement Kit

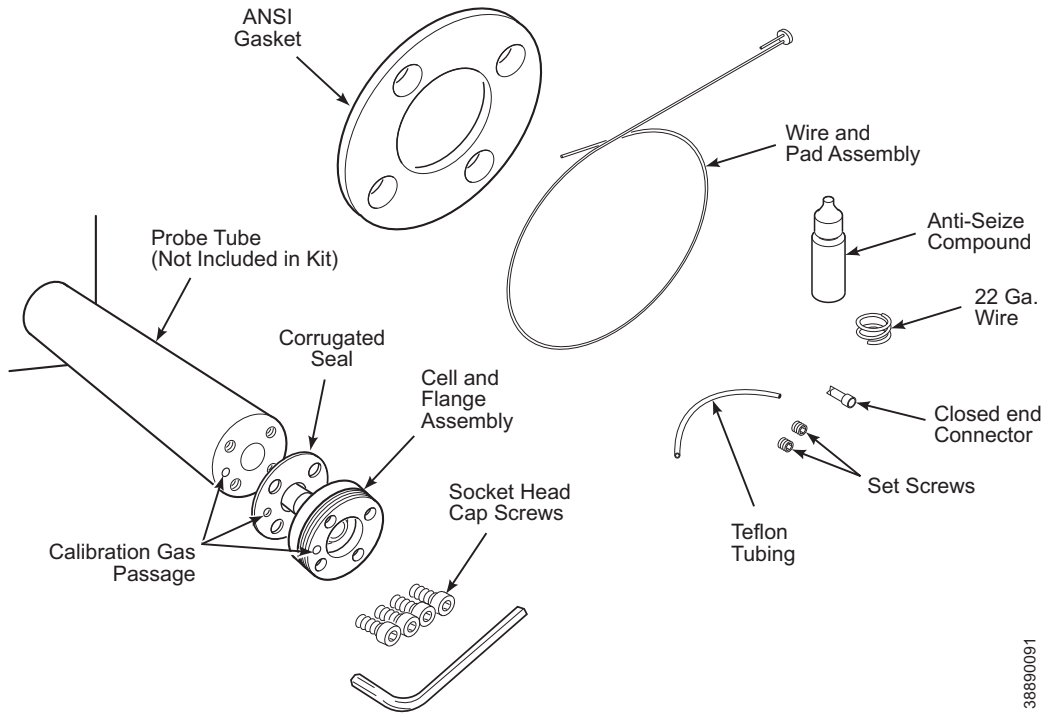

38890091

Table 10-1. Replacement Parts for Probe (Continued)

Figure and Index Number	Part Number	Description
10-1	4847B61G02	ANSI 18" Cell Replacement Kit*
10-1	4847B61G03	ANSI 3' Cell Replacement Kit*
10-1	4847B61G04	ANSI 6' Cell Replacement Kit*
10-1	4847B61G05	ANSI 9' Cell Replacement Kit*
10-1	4847B61G06	ANSI 12' Cell Replacement Kit*
10-1	4847B61G34	ANSI 15' Cell Replacement Kit*
10-1	4847B61G35	ANSI 18' Cell Replacement Kit*
10-1	4847B61G14	DIN 18" Cell Replacement Kit*
10-1	4847B61G15	DIN 3' Cell Replacement Kit*
10-1	4847B61G16	DIN 6' Cell Replacement Kit*
10-1	4847B61G17	DIN 9' Cell Replacement Kit*
10-1	4847B61G18	DIN 12' Cell Replacement Kit*

\*Includes pad and wire

# Oxymitter 4000

Table 10-1. Replacement Parts for Probe (Continued)

Figure and Index Number	Part Number	Description
	4849B94G01	ANSI High Sulfur/HI Resistant Cell Only
10-1	4849B94G02	ANSI 18" Cell Replacement Kit, High Sulfur/HCl Resistant*
10-1	4849B94G03	ANSI 3' Cell Replacement Kit, High Sulfur/HCl Resistant*
10-1	4849B94G04	ANSI 6' Cell Replacement Kit, High Sulfur/HCl Resistant*
10-1	4849B94G05	ANSI 9' Cell Replacement Kit, High Sulfur/HCl Resistant*
10-1	4849B94G06	ANSI 12' Cell Replacement Kit, High Sulfur/HCl Resistant*
10-1	4849B94G26	ANSI 15' Cell Replacement Kit, High Sulfur/HCl Resistant*
10-1	4849B94G27	ANSI 18' Cell Replacement Kit, High Sulfur/HCl Resistant*
	4849B94G13	DIN High Sulfur/HCl Resistant Cell Only
10-1	4849B94G14	DIN 18" Cell Replacement Kit, High Sulfur/HCl Resistant*
10-1	4849B94G15	DIN 3' Cell Replacement Kit, High Sulfur/HCl Resistant*
10-1	4849B94G16	DIN 6' Cell Replacement Kit, High Sulfur/HCl Resistant*
10-1	4849B94G17	DIN 9' Cell Replacement Kit, High Sulfur/HCl Resistant*
10-1	4849B94G18	DIN 12' Cell Replacement Kit, High Sulfur/HCl Resistant*
2-4	3D39003G11	DIN 9' Abrasive Shield Assy.
2-4	3D39003G12	DIN 12' Abrasive Shield Assy.
2-4	3D39003G13	ANSI 18" Abrasive Shield Assy
2-4	3D39003G15	DIN 18" Abrasive Shield Assy.
2-4	3D39003G25	ANSI 15' Abrasive Shield Assy.
2-4	3D39003G28	ANSI 18' Abrasive Shield Assy.
9-12	4513C61G03	18" Contact and Thermocouple Replacement Assembly
9-12	4513C61G04	3' Contact and Thermocouple Replacement Assembly
9-12	4513C61G05	6' Contact and Thermocouple Replacement Assembly
9-12	4513C61G06	9' Contact and Thermocouple Replacement Assembly
9-12	4513C61G07	12' Contact and Thermocouple Replacement Assembly
9-12	4513C61G13	15' Contact and Thermocouple Replacement Assembly
9-12	4513C61G14	18' Contact and Thermocouple Replacement Assembly

\*Includes pad and wire

Table 10-1. Replacement Parts for Probe (Continued)

Figure and Index Number	Part Number	Description
1-11, 9-11	3534B18G01	Ceramic Diffuser
1-11	3535B60G01	Ceramic Diffuser with Dust Seal
1-11	3535B62G01	Flame Arrestor Ceramic Diffuser
1-11	3535B63G01	Flame Arrestor Ceramic Diffuser with Dust Seal
1-12	4843B37G01	Snubber Diffuser
1-12	4843B38G02	Snubber Diffuser with Dust Seal
1-12	4846B70G01	Flame Arrestor Snubber Diffuser
1-12	4846B71G01	Flame Arrestor Snubber Diffuser with Dust Seal
9-11	3534B48G01	Vee Deflector Assy.
1-13	4851B89G04	Cup Type Diffusion Assembly, 10 microns
1-13	4851B89G05	Cup Type Diffusion Assembly, 40 microns
1-13	4851B90G04	Cup Type Diffusion Assembly/Dust Seal, 10 microns
1-13	4851B90G05	Cup Type Diffusion Assembly/Dust Seal, 40 microns
10-2	3535B42G02	Probe Disassembly Kit

Figure 10-2. Probe Disassembly Kit

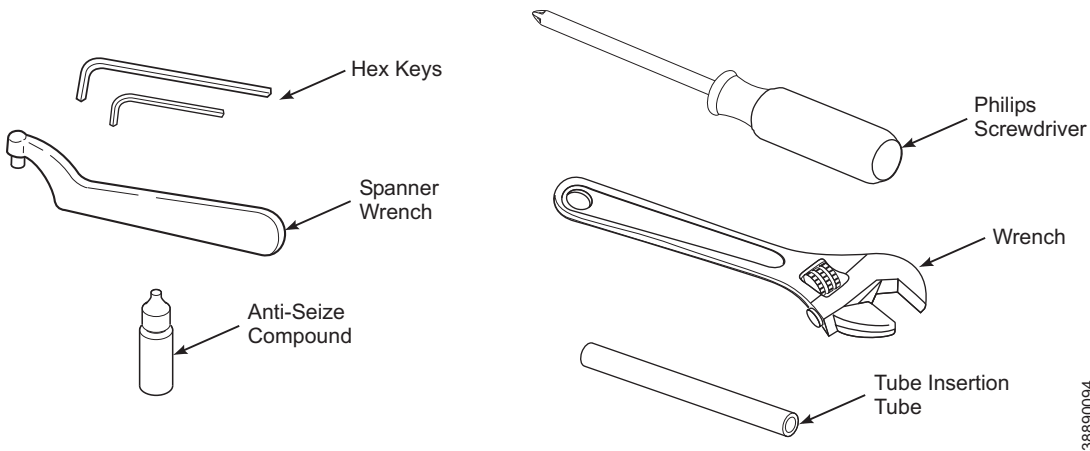

38890094

### ELECTRONICS REPLACEMENT PARTS

Table 10-2. Replacement Parts  
for Electronics

Figure and Index Number	Part Number	Description
9-3, 10	120039076	O-Ring
9-3, 11	5R10145G01	Cover
9-3, 11A	6A00170G01	Cover, with Window
9-3, 12	3D39861G01	Electronic Assembly
9-3, 14	4849B72H01	Membrane Keypad English
9-3, 14	4849B72H02	Membrane Keypad German
9-3, 14	4849B72H03	Membrane Keypad French
9-3, 14	4849B72H04	Membrane Keypad Spanish
9-3, 14	4849B72H05	Membrane Keypad Italian
9-3, 14A	6A00115G01	LOI Module (Local Operator Interface)
9-3, 21	5R10146G01	Housing (No Covers)
9-3, 25	08732-0002-0002	Termination Block Transient Protected
9-3, 27A	120039078	O-Ring
9-4, 5	6A00091G01	Junction Box
9-4, 8	6A00143G01	Adapter Board
9-4, 10	120039076	O-Ring
9-4, 11	5R10145G01	Cover
9-4, 11A	6A00170G01	Cover, with Window
9-4, 12	3D39861G01	Electronic Assembly
9-4, 14A	6A00115G01	LOI Module (Local Operator Interface)
9-4, 21	5R10146G01	Housing
9-4, 25	08732-0002-0002	Termination Block, Transient Protected
9-4, 27A	120039078	O-Ring
9-4, 35	6A00201G01	Cable Assembly, 20 ft. (6 m)
9-4, 35	6A00201G02	Cable Assembly, 40 ft. (12 m)
9-4, 35	6A00201G03	Cable Assembly, 60 ft. (18 m)
9-4, 35	6A00201G04	Cable Assembly, 80 ft. (24 m)
9-4, 35	6A00201G05	Cable Assembly, 100 ft. (30 m)
9-4, 35	6A00201G06	Cable Assembly, 150 ft. (46 m)
9-4, 35	6A00201G07	Cable Assembly, 200 ft. (61 m)
9-4, 36	3D39866G02	Termination Block, Transient Protected, Remote Probe Head

Table 10-3. Replacement Parts  
for Calibration Components

Figure and Index Number	Part Number	Description
11-5	1A99119G01	Calibration Gas Bottles - 0.4% and 8% O <sub>2</sub> , balance nitrogen - 550 liters each*
11-5	1A99119G02	Two Flow Regulators (for calibration gas bottles)
11-5	1A99119G03	Bottle rack

\*Calibration gas bottles cannot be shipped via airfreight.

## Section 11      Optional Accessories

---

HART Handheld 375 Communicator .....	page 11-1
Asset Management Solutions (AMS) .....	page 11-2
By-Pass Packages .....	page 11-2
IMPS 4000 Intelligent Multiprobe Test Gas Sequencer ..	page 11-3
SPS 4001B Single Probe Autocalibration Sequencer ...	page 11-4
O <sub>2</sub> Calibration Gas .....	page 11-5
Catalyst Regeneration .....	page 11-6

---

### HART HANDHELD 375 COMMUNICATOR

Figure 11-1. HART Model 375  
Handheld Communicator

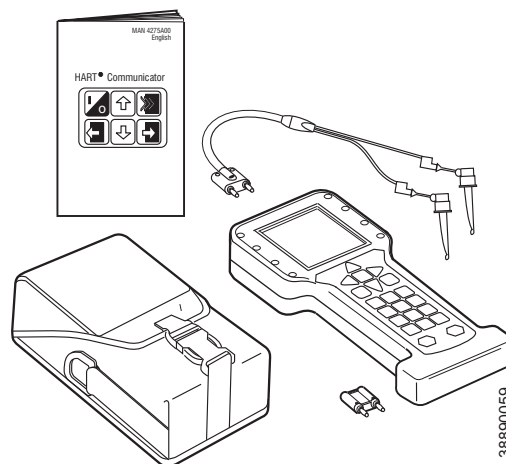

The HART Handheld 275/375 Communicator is an interface device that provides a common communication link to HART-compatible instruments, such as the Oxymitter 4000. HART Communications Protocol permits all the information available from the Oxymitter 4000's electronics to be transmitted over standard 4-20 mA signal wires. By attaching the HART handheld communicator at a termination point along the 4-20 mA signal line, a technician can diagnose problems and configure and calibrate the Oxymitter 4000 as if he or she were standing in front of the instrument.

For more information, call Emerson Process Management at 1-800-433-6076.

# Oxymitter 4000

## **ASSET MANAGEMENT SOLUTIONS (AMS)**

Asset Management Solutions (AMS) software works in conjunction with the HART Communication Protocol and offers the capability to communicate with all HART plant devices from a single computer terminal.

For more information, call Emerson Process Management at 1-800-433-6076.

## **BY-PASS PACKAGES**

Figure 11-2. By-Pass Mounting

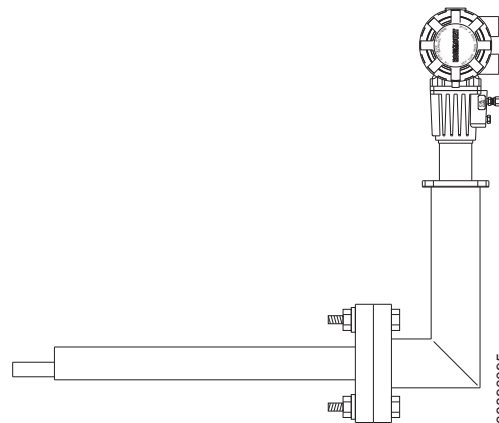

The specially designed Rosemount Analytical By-Pass Package for oxygen analyzers has proven to withstand the high temperatures in process heaters while providing the same advantages offered by the in situ sensor. Inconel or Kanthal steel tubes provide effective resistance to corrosion, and the package uses no moving parts, air pumps, or other components common to other sampling systems.

For more information, call Emerson Process Management at 1-800-433-6076.



**IMPS 4000 INTELLIGENT  
MULTIPROBE TEST GAS  
SEQUENCER**

Figure 11-3. IMPS 4000

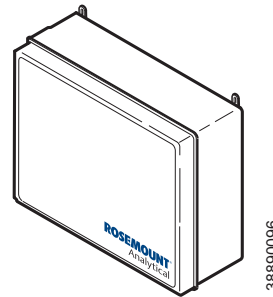

The IMPS 4000 Intelligent Multiprobe Test Gas Sequencer is housed within an IP56 (NEMA 4X) enclosure and has the intelligence to provide calibration gas sequencing of up to four Oxymitter 4000 units to accommodate automatic and semi-automatic calibration routines.

This sequencer works in conjunction with the Oxymitter 4000 CALIBRATION RECOMMENDED feature, eliminating out-of-calibration occurrences and the need to send a technician to the installation site. In addition, the SPS 4001B provides a remote contact input to initiate a calibration from a remote location and relay outputs to alert when a calibration is in progress, an Oxymitter 4000 is out of calibration, calibration gases are on, and calibration gas pressure is low.

For more information, call Emerson Process Management at 1-800-433-6076.

# Oxymitter 4000

## SPS 4001B SINGLE PROBE AUTOCALIBRATION SEQUENCER

Figure 11-4. SPS 4001B

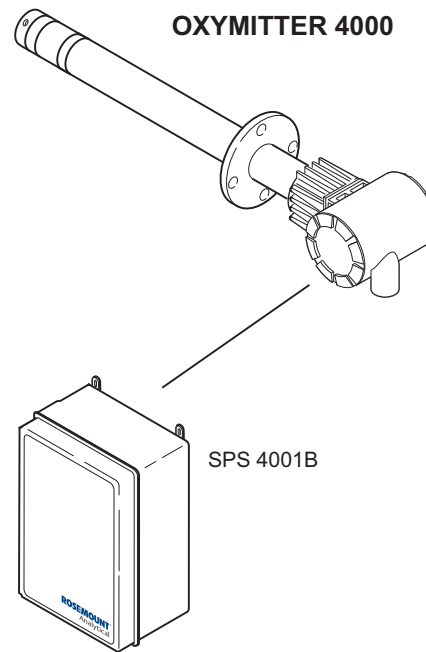

38890097

Emerson Process Management specifically designed the SPS 4001B Single Probe Autocalibration Sequencer to provide the capability to perform automatic or on-demand Oxymitter 4000 calibrations. The SPS 4001B is fully enclosed in a NEMA cabinet suited for wall-mounting. This cabinet provides added protection against dust and minor impacts.

The SPS 4001B works in conjunction with the Oxymitter 4000's CALIBRATION RECOMMENDED feature, eliminating out-of-calibration occurrences and the need to send a technician to the installation site. In addition, the SPS 4001B provides a remote contact input to initiate a calibration from a remote location and relay outputs to indicate when a calibration is in progress or the Oxymitter 4000 is out of calibration.

For more information, call Emerson Process Management at 1-800-433-6076.

**O<sub>2</sub> CALIBRATION GAS**

Figure 11-5. Calibration Gas Bottles

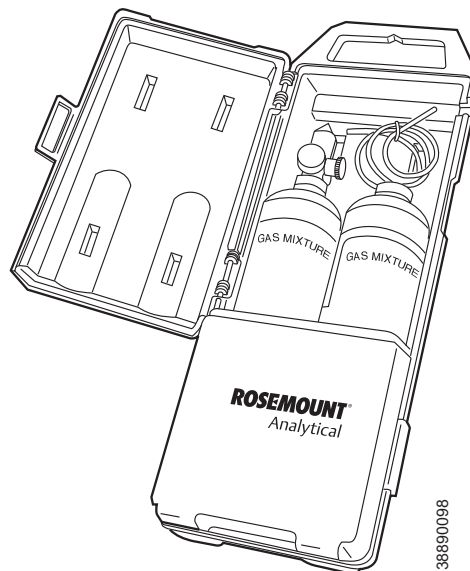

Rosemount Analytical's O<sub>2</sub> Calibration Gas and Service Kits have been carefully designed to provide a more convenient and fully portable means of testing, calibrating, and servicing.

Rosemount Analytical's oxygen analyzers. These lightweight, disposable gas cylinders eliminate the need to rent gas bottles.

For more information, call Emerson Process Management at 1-800-433-6076.

# Oxymitter 4000

## CATALYST REGENERATION

Figure 11-6. Catalyst Regeneration

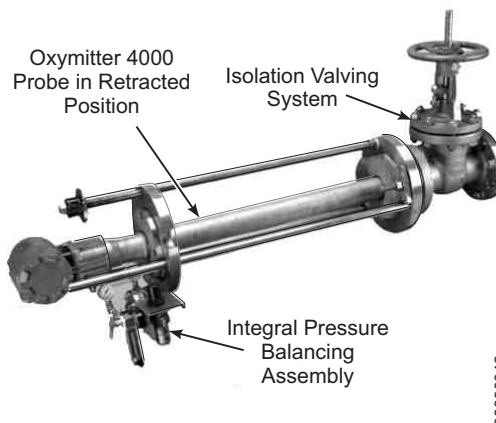

Measure O<sub>2</sub> in catalyst regenerators at pressures up to 50 psi. In-situ design resists plugging due to catalyst fines Class I, Div. I, Group B, C, and D.

Optional pressure balancing arrangement. Optional isolation valving system permits installation and withdrawal while the process is running. Specified by UOP.

See Application Data Sheet ADS 106-300F.A01, Isolation Valving System.

## OXYBALANCE DISPLAY AND AVERAGING SYSTEM

Figure 11-7. OxyBalance

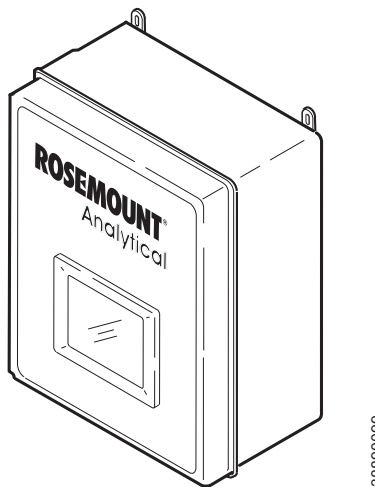

Optional OxyBalance Display and Averaging System. Reviews up to eight 4-20 mA signals from individual probes. Trends individual outputs, calculates four programmable averages as additional 4-20 mA outputs.

---

# Appendix A      Safety Data

---



Safety Instructions .....	page A-2
Safety Data Sheet for Ceramic Fiber Products .....	page A-24

---

## SAFETY INSTRUCTIONS

**IMPORTANT****SAFETY INSTRUCTIONS FOR THE WIRING  
AND INSTALLATION OF THIS APPARATUS**



The following safety instructions apply specifically to all EU member states. They should be strictly adhered to in order to assure compliance with the Low Voltage Directive. Non-EU states should also comply with the following unless superseded by local or National Standards.

1. Adequate earth connections should be made to all earthing points, internal and external, where provided.
2. After installation or troubleshooting, all safety covers and safety grounds must be replaced. The integrity of all earth terminals must be maintained at all times.
3. Mains supply cords should comply with the requirements of IEC227 or IEC245.
4. All wiring shall be suitable for use in an ambient temperature of greater than 75°C.
5. All cable glands used should be of such internal dimensions as to provide adequate cable anchorage.
6. To ensure safe operation of this equipment, connection to the mains supply should only be made through a circuit breaker which will disconnect all circuits carrying conductors during a fault situation. The circuit breaker may also include a mechanically operated isolating switch. If not, then another means of disconnecting the equipment from the supply must be provided and clearly marked as such. Circuit breakers or switches must comply with a recognized standard such as IEC947. All wiring must conform with any local standards.
7. Where equipment or covers are marked with the symbol to the right, hazardous voltages are likely to be present beneath. These covers should only be removed when power is removed from the equipment - and then only by trained service personnel. 
8. Where equipment or covers are marked with the symbol to the right, there is a danger from hot surfaces beneath. These covers should only be removed by trained service personnel when power is removed from the equipment. Certain surfaces may remain hot to the touch. 
9. Where equipment or covers are marked with the symbol to the right, refer to the Operator Manual for instructions. 
10. All graphical symbols used in this product are from one or more of the following standards: EN61010-1, IEC417, and ISO3864.
11. Where equipment or labels are marked "Do Not Open While Energized" or similar, there is a danger of ignition in areas where an explosive atmosphere is present. This equipment should only be opened when power is removed and adequate time as specified on the label or in the instruction manual has been allowed for the equipment to cool down - and then only by trained service personnel.

## **DŮLEŽITÉ**

### **Bezpečnostní pokyny pro zapojení a instalaci zařízení**



**Následující bezpečnostní pokyny se speciálně vztahují na všechny členské státy EU. Pokyny by měly být přísně dodržovány, aby se zajistilo splnění Směrnice o nízkém napětí. Pokud nejsou pokyny nahrazeny místními či národními normami, měly by je dodržovat i nečlenské státy EU.**

1. U všech zemnicích bodů, interních a externích, by mělo být vytvořeno odpovídající uzemnění.
2. Po instalaci nebo odstranění problémů musí být vyměněny všechny bezpečnostní kryty a uzemnění. Vždy musí být zajištěna integrita všech zemnicích svorek.
3. Síťové kabely by měly odpovídat požadavkům normy IEC227 nebo IEC245.
4. Všechna zapojení by měla být vhodná pro použití při vnějších teplotách nad 75 °C.
5. Všechna použitá kabelová hrdla by měla mít takové vnitřní rozměry, aby zajistila odpovídající zakotvení kabelu.
6. Správnou činnost zařízení zajistíte, vytvoříte-li připojení k napájecímu zdroji pouze přes jistič, který v případě poruchy odpojí všechny obvody s konduktory. Jistič může také obsahovat mechanický odpojovač. Pokud ho neobsahuje, musí být zajištěn a jasně označen jiný způsob odpojení zařízení od zdroje. Jističe nebo přepínače musí odpovídat uznávaným normám, např. IEC947. Všechna zapojení musí odpovídat místním normám.
7. Je-li zařízení nebo kryt označen symbolem na pravé straně, pravděpodobně se uvnitř nachází nebezpečné napětí. Tyto kryty by měly být sejmuty pouze po odpojení zařízení od zdroje - a to pouze kvalifikovaným zaměstnancem. 
8. Je-li zařízení nebo kryt označen symbolem na pravé straně, povrch zařízení může být velmi horký. Tyto kryty by měly být sejmuty pouze kvalifikovaným zaměstnancem po odpojení zařízení od zdroje. Některé povrchy mohou být stále horké. 
9. Je-li zařízení nebo kryt označen symbolem na pravé straně, přečtěte si nejprve instrukce v návodu k obsluze. 
10. Všechny grafické symboly používané u výrobku pocházejí z následujících norem: EN61010-1, IEC417 a ISO3864.
11. Pokud je zařízení nebo štítky označeno varováním „Je-li zařízení pod napětím, neotvírejte jej“ či podobným, může dojít ve výbušném prostředí ke vznícení. Zařízení lze otevřít pouze po jeho odpojení od zdroje a ponechání dostatečného času na vychladnutí, jak je uvedeno na štítku nebo v návodu k obsluze - a to pouze kvalifikovaným zaměstnancem.

## **VIGTIGT**

### **Sikkerhedsinstruktion for tilslutning og installation af dette udstyr.**

**Følgende sikkerhedsinstruktioner gælder specifikt i alle EU-medlemslande. Instruktionerne skal nøje følges for overholdelse af Lavspændingsdirektivet og bør også følges i ikke EU-lande medmindre andet er specificeret af lokale eller nationale standarder.**



1. Passende jordforbindelser skal tilsluttes alle jordklemmer, interne og eksterne, hvor disse forefindes.
2. Efter installation eller fejlfinding skal alle sikkerhedsdæksler og jordforbindelser reetableres.
3. Forsyningskabler skal opfylde krav specificeret i IEC227 eller IEC245.
4. Alle ledningstilslutninger skal være konstrueret til omgivelsestemperatur højere end 75°C.
5. Alle benyttede kabelforskrutninger skal have en intern dimension, så passende kabelafastning kan etableres.
6. For opnåelse af sikker drift og betjening skal der skabes beskyttelse mod indirekte berøring gennem afbryder (min. 10A), som vil afbryde alle kredsløb med elektriske ledere i fejlsituation. Afbryderen skal indholde en mekanisk betjent kontakt. Hvis ikke skal anden form for afbryder mellem forsyning og udstyr benyttes og mærkes som sådan. Afbrydere eller kontakter skal overholde en kendt standard som IEC947.
7. Hvor udstyr eller dæksler er mærket med dette symbol, er farlige spændinger normalt forekommende bagved. Disse dæksler bør kun afmonteres, når forsyningsspændingen er frakoblet - og da kun af instrueret servicepersonale. 
8. Hvor udstyr eller dæksler er mærket med dette symbol, forefindes meget varme overflader bagved. Disse dæksler bør kun afmonteres af instrueret servicepersonale, når forsyningsspænding er frakoblet. Visse overflader vil stadig være for varme at berøre i op til 45 minutter efter frakobling. 
9. Hvor udstyr eller dæksler er mærket med dette symbol, se da i betjeningsmanual for instruktion. 
10. Alle benyttede grafiske symboler i dette udstyr findes i én eller flere af følgende standarder:- EN61010-1, IEC417 & ISO3864.
11. Når udstyr eller etiketter er mærket "Må ikke åbnes, mens udstyret tilføres strøm" eller lignende, er der fare for antændelse i områder, hvor der er en eksplosiv atmosfære. Dette udstyr må kun åbnes, når strømkilden er fjernet, og der er gået tilstrækkelig tid til, at udstyret er kølet ned. Den nødvendige tid hertil er angivet på etiketten eller i brugervejledningen. Udstyret må kun åbnes af en faglært person.



## **BELANGRIJK**

**Veiligheidsvoorschriften voor de aansluiting en installatie van dit toestel.**

**De hierna volgende veiligheidsvoorschriften zijn vooral bedoeld voor de EU lidstaten. Hier moet aan gehouden worden om de onderworpenheid aan de Laag Spannings Richtlijn (Low Voltage Directive) te verzekeren. Niet EU staten zouden deze richtlijnen moeten volgen tenzij zij reeds achterhaald zouden zijn door plaatselijke of nationale voorschriften.**

1. Degelijke aardingsaansluitingen moeten gemaakt worden naar alle voorziene aardpunten, intern en extern.
2. Na installatie of controle moeten alle veiligheidsdeksels en -aarding terug geplaatst worden. Ten alle tijde moet de betrouwbaarheid van de aarding behouden blijven.
3. Voedingskabels moeten onderworpen zijn aan de IEC227 of de IEC245 voorschriften.
4. Alle bekabeling moet geschikt zijn voor het gebruik in omgevingstemperaturen, hoger dan 75°C.
5. Alle wartels moeten zo gedimensioneerd zijn dat een degelijke kabel bevestiging verzekerd is.
6. Om de veilige werking van dit toestel te verzekeren, moet de voeding door een stroomonderbreker gevoerd worden (min 10A) welke alle draden van de voeding moet onderbreken. De stroomonderbreker mag een mechanische schakelaar bevatten. Zoniet moet een andere mogelijkheid bestaan om de voedingsspanning van het toestel te halen en ook duidelijk zo zijn aangegeven. Stroomonderbrekers of schakelaars moeten onderworpen zijn aan een erkende standaard zoals IEC947.
7. Waar toestellen of deksels aangegeven staan met het symbool is er meestal hoogspanning aanwezig. Deze deksels mogen enkel verwijderd worden nadat de voedingsspanning werd afgelegd en enkel door getraind onderhoudspersoneel. 
8. Waar toestellen of deksels aangegeven staan met het symbool is er gevaar voor hete oppervlakken. Deze deksels mogen enkel verwijderd worden door getraind onderhoudspersoneel nadat de voedingsspanning verwijderd werd. Sommige oppervlakken kunnen 45 minuten later nog steeds heet aanvoelen. 
9. Waar toestellen of deksels aangegeven staan met het symbool gelieve het handboek te raadplegen. 
10. Alle grafische symbolen gebruikt in dit produkt, zijn afkomstig uit een of meer van devolgende standaards: EN61010-1, IEC417 en ISO3864.
11. Op plaatsen waar uitrusting of etiketten zijn voorzien van een melding als "Niet openen bij aanwezigheid van spanning" bestaat er brandgevaar in omgevingen waar een explosieve atmosfeer aanwezig is. Deze uitrusting mag uitsluitend worden geopend wanneer het niet meer onder spanning staat en de uitrusting gedurende de voorgeschreven tijd op het etiket of in de handleiding is afgekoeld - en dan uitsluitend door voldoende opgeleid onderhoudspersoneel.

## **BELANGRIJK**

**Veiligheidsinstructies voor de bedrading en installatie van dit apparaat.**

**Voor alle EU lidstaten zijn de volgende veiligheidsinstructies van toepassing. Om aan de geldende richtlijnen voor laagspanning te voldoen dient men zich hieraan strikt te houden. Ook niet EU lidstaten dienen zich aan het volgende te houden, tenzij de lokale wetgeving anders voorschrijft.**

1. Alle voorziene interne- en externe aardaansluitingen dienen op adequate wijze aangesloten te worden.
2. Na installatie, onderhouds- of reparatie werkzaamheden dienen alle beschermdeksels /kappen en aarding en om reden van veiligheid weer aangebracht te worden.
3. Voedingskabels dienen te voldoen aan de vereisten van de normen IEC 227 of IEC 245.
4. Alle bedrading dient geschikt te zijn voor gebruik bij een omgevings temperatuur boven 75°C.
5. Alle gebruikte kabelwartels dienen dusdanige inwendige afmetingen te hebben dat een adequate verankering van de kabel wordt verkregen.
6. Om een veilige werking van de apparatuur te waarborgen dient de voeding uitsluitend plaats te vinden via een meerpole automatische zekering (min.10A) die alle spanningvoerende geleiders verbreekt indien een foutconditie optreedt. Deze automatische zekering mag ook voorzien zijn van een mechanisch bediende schakelaar. Bij het ontbreken van deze voorziening dient een andere als zodanig duidelijk aangegeven mogelijkheid aanwezig te zijn om de spanning van de apparatuur af te schakelen. Zekeringen en schakelaars dienen te voldoen aan een erkende standaard zoals IEC 947.
7. Waar de apparatuur of de beschermdeksels/kappen gemarkeerd zijn met het volgende symbool, kunnen zich hieronder spanning voerende delen bevinden die gevaar op kunnen leveren. Deze beschermdeksels/kappen mogen uitsluitend verwijderd worden door getraind personeel als de spanning is afgeschakeld. 
8. Waar de apparatuur of de beschermdeksels/kappen gemarkeerd zijn met het volgende symbool, kunnen zich hieronder hete oppervlakken of onderdelen bevinden. Bepaalde delen kunnen mogelijk na 45 min. nog te heet zijn om aan te raken. 
9. Waar de apparatuur of de beschermdeksels/kappen gemarkeerd zijn met het volgende symbool, dient men de bedieningshandleiding te raadplegen. 
10. Alle grafische symbolen gebruikt bij dit produkt zijn volgens een of meer van de volgende standaarden: EN 61010-1, IEC 417 & ISO 3864.
11. Op plaatsen waar uitrusting of etiketten zijn voorzien van een melding als "Niet openen bij aanwezigheid van spanning" bestaat er brandgevaar in omgevingen waar een explosieve atmosfeer aanwezig is. Deze uitrusting mag uitsluitend worden geopend wanneer het niet meer onder spanning staat en de uitrusting gedurende de voorgeschreven tijd op het etiket of in de handleiding is afgekoeld - en dan uitsluitend door voldoende opgeleid onderhoudspersoneel.

## **WICHTIG**

**Sicherheitshinweise für den Anschluß und die Installation dieser Geräte.**

**Die folgenden Sicherheitshinweise sind in allen Mitgliederstaaten der europäischen Gemeinschaft gültig. Sie müssen strikt eingehalten werden, um der Niederspannungsrichtlinie zu genügen.**

**Nichtmitgliedsstaaten der europäischen Gemeinschaft sollten die national gültigen Normen und Richtlinien einhalten.**



1. Alle intern und extern vorgesehenen Erdungen der Geräte müssen ausgeführt werden.
2. Nach Installation, Reparatur oder sonstigen Eingriffen in das Gerät müssen alle Sicherheitsabdeckungen und Erdungen wieder installiert werden. Die Funktion aller Erdverbindungen darf zu keinem Zeitpunkt gestört sein.
3. Die Netzspannungsversorgung muß den Anforderungen der IEC227 oder IEC245 genügen.
4. Alle Verdrahtungen sollten mindestens bis 75°C ihre Funktion dauerhaft erfüllen.
5. Alle Kabeldurchführungen und Kabelverschraubungen sollten in Ihrer Dimensionierung so gewählt werden, daß diese eine sichere Verkabelung des Gerätes ermöglichen.
6. Um eine sichere Funktion des Gerätes zu gewährleisten, muß die Spannungsversorgung über mindestens 10 A abgesichert sein. Im Fehlerfall muß dadurch gewährleistet sein, daß die Spannungsversorgung zum Gerät bzw. zu den Geräten unterbrochen wird. Ein mechanischer Schutzschalter kann in dieses System integriert werden. Falls eine derartige Vorrichtung nicht vorhanden ist, muß eine andere Möglichkeit zur Unterbrechung der Spannungszufuhr gewährleistet werden mit Hinweisen deutlich gekennzeichnet werden. Ein solcher Mechanismus zur Spannungsunterbrechung muß mit den Normen und Richtlinien für die allgemeine Installation von Elektrogeräten, wie zum Beispiel der IEC947, übereinstimmen.
7. Mit dem Symbol sind Geräte oder Abdeckungen gekennzeichnet, die eine gefährliche (Netzspannung) Spannung führen. Die Abdeckungen dürfen nur entfernt werden, wenn die Versorgungsspannung unterbrochen wurde. Nur geschultes Personal darf an diesen Geräten Arbeiten ausführen.
8. Mit dem Symbol sind Geräte oder Abdeckungen gekennzeichnet, in bzw. unter denen heiße Teile vorhanden sind. Die Abdeckungen dürfen nur entfernt werden, wenn die Versorgungsspannung unterbrochen wurde. Nur geschultes Personal darf an diesen Geräten Arbeiten ausführen. Bis 45 Minuten nach dem Unterbrechen der Netzzufuhr können derartig Teile noch über eine erhöhte Temperatur verfügen.
9. Mit dem Symbol sind Geräte oder Abdeckungen gekennzeichnet, bei denen vor dem Eingriff die entsprechenden Kapitel im Handbuch sorgfältig durchgelesen werden müssen.
10. Alle in diesem Gerät verwendeten graphischen Symbole entspringen einem oder mehreren der nachfolgend aufgeführten Standards: EN61010-1, IEC417 & ISO3864.
11. Wenn Geräte oder Etiketten mit dem Hinweis "Nicht unter Spannung öffnen" oder ähnlichen Hinweisen versehen sind, besteht in explosionsgefährdeten Umgebungen Entzündungsgefahr. Das Gerät darf nur geöffnet werden, wenn es nicht ans Stromnetz angeschlossen und entsprechend der Zeitangaben auf dem Etikett bzw. in der Betriebsanleitung ausreichend abgekühlt ist. Das Gerät darf nur von geschultem Service-Personal geöffnet werden.



## ΣΗΜΑΝΤΙΚΟ

**Οδηγισ ασφαλειασ για την καλωδιωση και εγκατασταση της συσκευησ**



**Οι ακόλουθες οδηγίες ασφαλείας εφαρμόζονται ειδικά για όλες τις χώρες μέλη της Ευρωπαϊκής Κοινότητας. Θα πρέπει να ακολουθούνται αυστηρά ώστε να εξασφαλιστεί η συμβατότητα με τις οδηγίες για τη Χαμηλή Τάση. Χώρες που δεν είναι μέλη της Ευρωπαϊκής Κοινότητας θα πρέπει επίσης να ακολουθούν τις οδηγίες, εκτός εάν αυτές αντικαθίστανται από τα Τοπικά ή Εθνικά πρότυπα.**

1. Επαρκείς συνδέσεις γείωσης θα πρέπει να γίνονται σε όλα τα σημεία γείωσης, εσωτερικά και εξωτερικά, όπου υπάρχουν.
2. Μετά την εγκατάσταση ή την αντιμετώπιση σφαλμάτων, όλα τα καλύμματα ασφαλείας και οι γειώσεις ασφαλείας πρέπει να επανεγκαθίστανται. Η καλή κατάσταση όλων των ακροδεκτών γείωσης πρέπει να συντηρείται διαρκώς.
3. Τα καλώδια τροφοδοσίας πρέπει να πληρούν τις απαιτήσεις των IEC227 ή IEC245.
4. Όλες οι καλωδιώσεις θα πρέπει να είναι κατάλληλες για χρήση σε θερμοκρασία χώρου υψηλότερη από 75°C.
5. Όλοι οι στυπιοθλίπτες θα πρέπει να είναι τέτοιων εσωτερικών διαστάσεων, ώστε να παρέχουν επαρκή στερέωση των καλωδίων.
6. Για τη διασφάλιση ασφαλούς λειτουργίας αυτής της συσκευής, η σύνδεση τροφοδοσίας θα πρέπει να γίνεται μόνο μέσω ασφαλειοδιακόπτη, ο οποίος θα αποσυνδέει όλους τους ηλεκτροφόρους αγωγούς των κυκλωμάτων, στη διάρκεια κατάστασης σφάλματος. Ο ασφαλειοδιακόπτης μπορεί επίσης να περιλαμβάνει μηχανικό διακόπτη απομόνωσης. Εάν δεν περιλαμβάνει, τότε άλλα μέσα αποσύνδεσης της συσκευής από την τροφοδοσία πρέπει να παροχηθούν και να σημανθούν σαφώς ως τέτοια. Οι ασφαλειοδιακόπτες ή διακόπτες πρέπει να συμμορφώνονται με αναγνωρισμένα πρότυπα όπως το IEC947. Όλες οι καλωδιώσεις πρέπει να συμμορφώνονται με τα τοπικά πρότυπα.
7. Όπου συσκευές ή καλύμματα είναι σημασμένα με το σύμβολο που εικονίζεται δεξιά, επικίνδυνες τάσεις ενυπάρχουν κάτω από αυτά. Αυτά τα καλύμματα θα πρέπει να αφαιρούνται μόνο όταν έχει αφαιρεθεί η τροφοδοσία από τη συσκευή - και στην περίπτωση αυτή, μόνο από ειδικευμένο τεχνικό προσωπικό. 
8. Όπου συσκευές ή καλύμματα είναι σημασμένα με το σύμβολο που εικονίζεται δεξιά, υπάρχει κίνδυνος από καυτές επιφάνειες κάτω από αυτά. Τέτοια καλύμματα θα πρέπει να αφαιρούνται μόνο από ειδικευμένο τεχνικό προσωπικό, όταν έχει αφαιρεθεί η τροφοδοσία από τη συσκευή. Κάποιες επιφάνειες μπορούν να παραμένουν ζεστές στην αφή. 
9. Όπου συσκευές ή καλύμματα είναι σημασμένα με το σύμβολο που εικονίζεται δεξιά, ανατρέξτε στις οδηγίες χρήσης της συσκευής. 
10. Όλα τα γραφικά σύμβολα που χρησιμοποιούνται σε αυτό το προϊόν είναι από ένα ή περισσότερα από τα εξής πρότυπα: EN61010-1, IEC417 και ISO3864.
11. Όπου συσκευή ή ετικέτα είναι σημασμένη με την ένδειξη "Μην ανοίγετε ενώ βρίσκεται σε λειτουργία" ή άλλη παρόμοια, υπάρχει κίνδυνος ανάφλεξης σε περιοχές με εκρηκτική ατμόσφαιρα. Ο παρών εξοπλισμός πρέπει να ανοίγεται μόνο όταν είναι εκτός ρεύματος και αφού παρέλθει ο κατάλληλος χρόνος που αναγράφεται στην ετικέτα ή στο εγχειρίδιο οδηγιών ώστε να ψυχθεί και μόνο από εκπαιδευμένο προσωπικό συντήρησης.

## OLULINE TEAVE

### Juhtmestiku ja seadme paigaldamisega seotud ohutusjuhised



Alljärgnevad ohutusjuhised rakenduvad eriti kõigi Euroopa Liidu liikmesriikide suhtes. Antud juhiseid tuleb täpselt järgida, et kindlustada vastavus madalpinge direktiiviga. Euroopa Liitu mittekuuluvad riigid peavad samuti alljärgnevaid juhiseid järgima, va juhul, kui on olemas vastavad kohalikud riiklikud standardid.

1. Ettenähtud maanduspunktide, nii sisemiste kui väliste jaoks tuleb tagada nõuetekohased maaühendused.
2. Pärast paigaldamist või rikketuvastust tuleb kõik turvaümbrised ja turvamaandused uuesti oma kohale seada. Kõigis olukordades tuleb säilitada kõigi maandusklemmide terviklikkus.
3. Toitejuhtmed peavad vastama IEC227 või IEC245 nõuetele.
4. Kogu juhtmestik peab sobima kasutamiseks üle 75°C õhutemperatuuri juures.
5. Kõik juhtmetihendid peavad sisemõõtmete poolest tagama nõuetekohased kaabliühendused.
6. Seadme ohutu töötamise tagamiseks peab ühendus toiteallikaga toimuma vaid läbi automaatkorgi, mis veaolukorras lülitab välja kõik voolukandjad. Automaatkorgil võib olla ka mehhaaniliselt reguleeritav lahkliüliti. Vastasel juhul peab seadme toiteallikast lahtiühendamiseks olema teine ja selgelt osutatud moodus. Automaatkorgid või -lülitid peavad vastama tunnustatud standarditele nagu nt IEC947. Kogu juhtmestik peab vastama kohalikele standarditele.
7. Seadmel või ümbristel asuv paremale osutav sümbol tähistab selle all leiduvat ohtlikku pinget. Selliste sümbolitega ümbriseid võib eemaldada vaid juhul, kui seade on toiteallikast lahti ühendatud ning ka siis ainult vastavate oskustega spetsialisti poolt. 
8. Seadmele või ümbristele märgitud paremale osutava sümboli all valitseb kuumadest pindadest tulenev oht. Nimetatud sümbolitega ümbriseid võib eemaldada vaid vastavate oskustega spetsialist, kui seade on toiteallikast lahti ühendatud. Teatud pinnad võivad puudutamise jaoks liiga kuumad olla. 
9. Seadmel või ümbristel leiduva paremale osutava sümboli korral vt juhiste jaoks Toimimisjuhendit.
10. Kõik selle toote juures kasutatavad graafilised sümbolid lähtuvad ühest või enamast järgmistest standarditest: EN61010-1, IEC417 ja ISO3864. 
11. Kui seadmele või siltidele on kirjutatud "Ärge avage voolutarbimine korral" vms, valitseb plahvatusohtlikus keskkonnas süttimise oht. Seadet võib avada ainult siis, kui toide on lahti ühendatud ning seadmel on võimaldatud sildil või kasutusjuhendis osutatud aja jooksul maha jahtuda -- ning ka sellisel juhul ainult vastavate oskustega spetsialisti poolt.

## **TÄRKEÄÄ**

**Turvallisuusohje, jota on noudatettava tämän laitteen asentamisessa ja kaapeloinnissa.**

**Seuraavat ohjeet pätevät erityisesti EU:n jäsenvaltioissa. Niitä täytyy ehdottomasti noudattaa jotta täytettäisiin EU:n matalajännittdirektiivin (Low Voltage Directive) yhteensopivuus. Myös EU:hun kuulumattomien valtioiden tulee noudattaa tätä ohjetta, elleivät kansalliset standardit estä sitä.**

1. Riittävät maadoituskytkennät on tehtävä kaikkiin maadoituspisteisiin, sisäisiin ja ulkoisiin.
2. Asennuksen ja vianetsinnän jälkeen on kaikki suojat ja suojamaat asennettava takaisin paikoilleen. Maadoitusliittimen kunnollinen toiminta täytyy aina ylläpitää.
3. Jännitesyöttöjohtimien täytyy täyttää IEC227 ja IEC245 vaatimukset.
4. Kaikkien johdotuksien tulee toimia >75°C lämpötiloissa.
5. Kaikkien läpivientiholkkien sisähalkaisijan täytyy olla sellainen että kaapeli lukkiutuu kun nolla kiinni.
6. Turvallisen toiminnan varmistamiseksi täytyy jännitesyöttö varustaa turvakytkimellä (min 10A), joka kytkee irti kaikki jännitesyöttöjohtimet vikatilanteessa. Suojaan täytyy myös sisältyä mekaaninen erotuskytkin. Jos ei, niin jännitesyöttö on pystyttävä katkaisemaan muilla keinoilla ja merkittävä siten että se tunnistetaan sellaiseksi. Turvakytkimien tai katkaisimien täytyy täyttää IEC947 standardin vaatimukset näkyvyydestä.
7. Mikäli laite tai kosketussuoja on merkitty tällä merkillä  on merkinnän takana tai alla hengenvaarallisen suuruinen jännite. Suojaa ei saa poistaa jänniteen ollessa kytkettynä laitteeseen ja poistamisen saa suorittaa vain alan asiantuntija.
8. Mikäli laite tai kosketussuoja on merkitty tällä merkillä  on merkinnän takana tai alla kuuma pinta. Suojaa saa poistaa vain alan asiantuntija kun jännitesyöttö on katkaistu. Tällainen pinta voi säilyä kosketuskuumana jopa 45 minuuttia.
9. Mikäli laite tai kosketussuoja on merkitty tällä merkillä  katso lisäohjeita käyttöohjekirjasta.
10. Kaikki tässä tuotteessa käytetyt graafiset symbolit ovat yhdestä tai useammasta seuraavista standardeista: EN61010-1, IEC417 & ISO3864.
11. Jos laitteessa tai tarrassa on merkintä "Älä avaa, kun virta on kytketty" tai vastaava, räjähdysvaarallisissa tiloissa on syttymisen vaara. Nämä laitteet voidaan avata vain silloin, kun virta ei ole kytkettynä ja laitteen on annettu jäähtyä tarrassa tai oppaassa määritetyn ajan. Tällöinkin laitteet saa avata vain koulutettu huoltohenkilökunta.

## **IMPORTANT**

**Consignes de sécurité concernant le raccordement et l'installation de cet appareil.**

**Les consignes de sécurité ci-dessous s'adressent particulièrement à tous les états membres de la communauté européenne. Elles doivent être strictement appliquées afin de satisfaire aux directives concernant la basse tension. Les états non membres de la communauté européenne doivent également appliquer ces consignes sauf si elles sont en contradiction avec les standards locaux ou nationaux.**



1. Un raccordement adéquat à la terre doit être effectuée à chaque borne de mise à la terre, interne et externe.
2. Après installation ou dépannage, tous les capots de protection et toutes les prises de terre doivent être remis en place, toutes les prises de terre doivent être respectées en permanence.
3. Les câbles d'alimentation électrique doivent être conformes aux normes IEC227 ou IEC245.
4. Tous les raccordements doivent pouvoir supporter une température ambiante supérieure à 75°C.
5. Tous les presse-étoupes utilisés doivent avoir un diamètre interne en rapport avec les câbles afin d'assurer un serrage correct sur ces derniers.
6. Afin de garantir la sécurité du fonctionnement de cet appareil, le raccordement à l'alimentation électrique doit être réalisé exclusivement au travers d'un disjoncteur (minimum 10A.) isolant tous les conducteurs en cas d'anomalie. Ce disjoncteur doit également pouvoir être actionné manuellement, de façon mécanique. Dans le cas contraire, un autre système doit être mis en place afin de pouvoir isoler l'appareil et doit être signalisé comme tel. Disjoncteurs et interrupteurs doivent être conformes à une norme reconnue telle IEC947.
7. Lorsque les équipements ou les capots affichent le symbole suivant, cela signifie que des tensions dangereuses sont présentes. Ces capots ne doivent être démontés que lorsque l'alimentation est coupée, et uniquement par un personnel compétent.
8. Lorsque les équipements ou les capots affichent le symbole suivant, cela signifie que des surfaces dangereusement chaudes sont présentes. Ces capots ne doivent être démontés que lorsque l'alimentation est coupée, et uniquement par un personnel compétent. Certaines surfaces peuvent rester chaudes jusqu'à 45 mn.
9. Lorsque les équipements ou les capots affichent le symbole suivant, se reporter au manuel d'instructions.
10. Tous les symboles graphiques utilisés dans ce produit sont conformes à un ou plusieurs des standards suivants: EN61010-1, IEC417 & ISO3864.
11. Les équipements comportant une étiquette avec la mention " Ne pas ouvrir sous tension " ou toute autre mention similaire peuvent créer un risque d'incendie dans les environnements explosifs. Ces équipements ne doivent être ouverts que lorsqu'ils sont hors tension et que la durée de refroidissement requise indiquée sur l'étiquette ou dans le manuel d'instructions s'est écoulée. En outre ils ne doivent être ouverts que par un personnel qualifié.



## FONTOS

### Biztonsági előírások a készülék vezetékéhez és üzembeállításához

**A következő biztonsági előírások kifejezetten vonatkoznak az összes EU-tagállamra. Ezeket szigorúan be kell tartani a Kisfeszültségű irányelvnek való megfelelés biztosításához. A nem EU-tagállamok szintén tartásuk be a következőket, kivéve ha a helyi és nemzeti szabványok azt másként nem írják elő.**



1. A megfelelő földelést biztosítani kell az összes rendelkezésre álló földelési ponton, legyen az belső vagy külső.
2. Az üzembeállítás vagy hibaelhárítás után az összes biztonsági burkolatot és biztonsági földvezetékét ki kell cserélni. A földelőkapcsok sértetlenségét mindig biztosítani kell.
3. A tápvezetékeknek eleget kell tenniük az IEC227 vagy IEC245 szabványokban megfogalmazott követelményeknek.
4. Az összes vezetéknek alkalmasnak kell lennie a 75 °C-nál magasabb környezeti hőmérséklet melletti használatra.
5. Az összes használt kábelvezető tömszelencének olyan belső méretűnek kell lennie, hogy biztosítsák a kábelek megfelelő lekötését.
6. A berendezés biztonságos működésének biztosításához az elektromos hálózathoz való csatlakozást csak megszakítón keresztül szabad megvalósítani, amely az összes áramot szállító vezeték bontja hibahelyzet esetén. A megszakító magában foglalhat egy mechanikusan működtethető áramtalanító kapcsolót is. Ellenkező esetben biztosítani kell a berendezés elektromos hálózatról történő lekapcsolásának más módját, és ezt világosan jelezni kell. A megszakítóknak vagy kapcsolóknak meg kell felelniük egy elismert szabványnak, például az IEC947 szabványnak. Az összes vezetéknek meg kell felelnie az összes helyi szabványnak.
7. Ha a berendezés vagy a burkolata a jobb oldalon látható szimbólummal jelzett, alatta valószínűleg veszélyes feszültség van jelen. Az ilyen burkolat csak a berendezés áramtalanítása után távolítható el - és csak képzett szervizszakember végezheti el. 
8. Ha a berendezés vagy a burkolata a jobb oldalon látható szimbólummal jelzett, fenn áll a veszélye, hogy alatta forró felületek találhatók. Az ilyen burkolatot csak képzett szervizszakember távolíthatja el a berendezés áramtalanítása után. Bizonyos felületek érintésre forróak maradhatnak. 
9. Ha a berendezés vagy a burkolata a jobb oldalon látható szimbólummal jelzett, tekintse meg az Üzemeltetési útmutató arra vonatkozó utasításait. 
10. A terméken használt grafikus szimbólumok a következő szabványok legalább egyikéből származnak: EN61010-1, IEC417 és ISO3864.
11. Ha a berendezésen vagy a címkéken a „Ne nyissa ki bekapcsolt állapotban” vagy hasonló felhívás szerepel, robbanásveszélyes környezetben fennáll a gyulladás veszélye. Ez a berendezés csak áramtalanítás után nyitható ki, a címkén vagy a kezelési útmutatóban szereplő, a berendezés lehűlését biztosító megfelelő idői ráhagyás után - és csak képzett szervizszakember végezheti el.



## **IMPORTANTE**

**Norme di sicurezza per il cablaggio e l'installazione dello strumento.**



**Le seguenti norme di sicurezza si applicano specificatamente agli stati membri dell'Unione Europea, la cui stretta osservanza è richiesta per garantire conformità alla Direttiva del Basso Voltaggio. Esse si applicano anche agli stati non appartenenti all'Unione Europea, salvo quanto disposto dalle vigenti normative locali o nazionali.**

1. Collegamenti di terra idonei devono essere eseguiti per tutti i punti di messa a terra interni ed esterni, dove previsti.
2. Dopo l'installazione o la localizzazione dei guasti, assicurarsi che tutti i coperchi di protezione siano stati collocati e le messa a terra siano collegate. L'integrità di ciascun morsetto di terra deve essere costantemente garantita.
3. I cavi di alimentazione della rete devono essere secondo disposizioni IEC227 o IEC245.
4. L'intero impianto elettrico deve essere adatto per uso in ambiente con temperature superiore a 75°C.
5. Le dimensioni di tutti i connettori dei cavi utilizzati devono essere tali da consentire un adeguato ancoraggio al cavo.
6. Per garantire un sicuro funzionamento dello strumento il collegamento alla rete di alimentazione principale dovrà essere eseguita tramite interruttore automatico (min.10A), in grado di disattivare tutti i conduttori di circuito in caso di guasto. Tale interruttore dovrà inoltre prevedere un sezionatore manuale o altro dispositivo di interruzione dell'alimentazione, chiaramente identificabile. Gli interruttori dovranno essere conformi agli standard riconosciuti, quali IEC947.
7. Il simbolo riportato sullo strumento o sui coperchi di protezione indica probabile presenza di elevati voltaggi. Tali coperchi di protezione devono essere rimossi esclusivamente da personale qualificato, dopo aver tolto alimentazione allo strumento. 
8. Il simbolo riportato sullo strumento o sui coperchi di protezione indica rischio di contatto con superfici ad alta temperatura. Tali coperchi di protezione devono essere rimossi esclusivamente da personale qualificato, dopo aver tolto alimentazione allo strumento. Alcune superfici possono mantenere temperature elevate per oltre 45 minuti. 
9. Se lo strumento o il coperchio di protezione riportano il simbolo, fare riferimento alle istruzioni del manuale Operatore. 
10. Tutti i simboli grafici utilizzati in questo prodotto sono previsti da uno o più dei seguenti standard: EN61010-1, IEC417 e ISO3864.
11. L'indicazione "Non aprire sotto tensione" o simili sull'apparecchiatura o sulle etichette segnala il pericolo di accensione nelle aree in cui è presente un'atmosfera esplosiva. L'apparecchiatura può essere aperta solo quando l'alimentazione è scollegata ed è trascorso il tempo indicato sull'etichetta o nel manuale delle istruzioni per consentirne il raffreddamento. L'operazione può essere effettuata esclusivamente da personale dell'assistenza qualificato.

## **SVARBU**

**Šio prietaiso laidų prijungimo ir instaliacijos saugos instrukcijos**



**Toliau išvardinti saugumo reikalavimai taikomi konkrečiai visoms ES šalims narėms. Jų turi būti griežtai paisoma, kad būtų užtikrintai laikomasi Žemos įtampos direktyvos. Ne ES narės taip pat turi laikytis toliau pateikiamų reikalavimų nebent juos pakeičia vietiniai ar Nacionaliniai standartai.**

1. Turi būti atliktas tinkamas įžeminimas visuose įžeminimo taškuose, vidiniuose ir išoriniuose, kur numatyta.
2. Visos apsauginės dangos ir įžemikliai po instaliacijos ar remonto turi būti pakeisti. Visų įžeminimo terminalų vientisumo priežiūra turi būti atliekama nuolat.
3. Maitinimo tinklo laidai turi atitikti IEC227 ar IEC245 reikalavimus.
4. Visi laidai turi būti tinkami naudojimui aplinkos temperatūroje, aukštesnėje nei 75°C.
5. Visi naudojamų kabelių riebokšliai turi būti tokių vidinių matmenų, kad būtų galimas tinkamas kabelio pritvirtinimas.
6. Saugaus šio prietaiso veikimo užtikrinimui, prijungimas prie maitinimo tinklo turi būti atliekamas tik per automatinį pertraukiklį, kuris atjungs visas grandines nešančius konduktorius linijos gedimo metu. Automatinis pertraukiklis taip pat gali turėti mechanškai veikiančią izoliavimo jungiklį. Jeigu ne, tuomet turi būti nurodytos kitos įrenginio atjungimo priemonės, ir aiškiai pažymėtos, kad jos tokios yra. Automatiniai perjungikliai ar jungikliai turi atitikti pripažintus standartus, tokius kaip IEC947. Visi laidai turi atitikti visus vietinius standartus.
7. Kur įrenginys ar dangos yra pažymėti simboliu dešinėje, žemiau turi būti pavojinga įtampa. Šios dangos turi būti nuimamos tik tada, kai srovė yra pašalinta iš įrenginio - ir tik tuomet tai turi atlikti apmokytas personalas. 
8. Ten kur įrenginys ar dangos yra pažymėti simboliu dešinėje, ten yra pavojus nuo karštų paviršių apačioje. Šios dangos gali būti nuimamos tik apmokyto personalo, kai srovė yra pašalinta iš įrenginio. Tam tikri paviršiai gali išlikti karšti liečiant. 
9. Ten kur įrenginys ar dangos yra pažymėti simboliu dešinėje, žr. nurodymus Valdymo instrukcijose.
10. Visi grafiniai simboliai naudojami šiam produktui yra iš vieno ar daugiau toliau išvardintų standartų: EN61010-1, IEC417, ir ISO3864. 
11. Ten, kur įrenginys ar etiketės yra pažymėti "Neatidaryti esant srovei tiekimui" ar panašiai, yra užsidegimo pavojus tose vietose, kur yra sprogstamoji atmosfera. Šis įrenginys gali būti atidarytas tuomet, kai yra pašalinta srovė, ir praėjęs atitinkamas laikas, nurodytas etiketėje ar valdymo instrukcijoje, pakankamas įrenginio ataušimui - ir tai tik apmokyto personalo.

## **SVARĪGI**



**Drošības norādījumi šīs iekārtas pievienošanai un uzstādīšanai**

**Turpmākie drošības norādījumi attiecas uz visām ES dalībvalstīm. Tie ir stingri jāievēro, lai nodrošinātu atbilstību Zemsprieguma direktīvai. Turpmāk norādītais jāievēro arī valstīs, kas nav ES dalībvalstis, ja vien šos norādījumus neaizstāj vietējie vai valsts standarti.**

1. Visi pieejamie iekšējie un ārējie zemējuma punkti ir atbilstoši jāiezemē.
2. Pēc uzstādīšanas vai problēmu risināšanas visi drošības pārsegi un drošības zemējuma savienojumi ir jāpievieno atpakaļ. Visiem zemējuma savienojumiem vienmēr jābūt iezemētiem.
3. Elektropadeves vadiem jāatbilst IEC227 vai IEC245 prasībām.
4. Visai elektroinstalācijai jābūt piemērotai lietošanai apkārtējā temperatūrā, kas pārsniedz 75°C.
5. Visu izmantoto kabeļu blīvju iekšējiem izmēriem jābūt tādiem, lai atbilstoši nostiprinātu kabeli.
6. Lai nodrošinātu šīs iekārtas drošu darbību, savienojums ar elektropadeves tīklu jāizveido, izmantojot slēdzi, kas kļūmes gadījumā atvienos visas ķēdes, kurās ir vadītāji. Slēdzī var būt iestrādāts arī mehānisks pārtraucējslēdzis. Ja tāda nav, tad ir jāuzstāda cita veida ierīce iekārtas atvienošanai no strāvas padeves un tā atbilstoši un skaidri jāmarķē. Slēdžiem jāatbilst kādam vispārāztītam standartam, piemēram, IEC947. Visai elektroinstalācijai jāatbilst vietējiem standartiem.
7. Vietās, kur iekārta vai tās pārsegi ir marķēti ar labajā pusē norādīto simbolu, visticamāk, zem tiem ir bīstams spriegums. Šos pārsegus drīkst noņemt tikai tad, ja iekārta ir atvienota no strāvas padeves, – un šos darbus drīkst veikt tikai atbilstoši apmācīti remontdarbu darbinieki. 
8. Vietās, kur iekārta vai tās pārsegi ir marķēti ar labajā pusē norādīto simbolu, apdraudējumu izraisa zem tiem esošās karstās virsmas. Šos pārsegus drīkst noņemt tikai atbilstoši apmācīti remontdarbu darbinieki, kad iekārta ir atvienota no strāvas padeves. Iespējams, dažas virsmas arī pēc iekārtas atvienošanas paliks karstas. 
9. Ja iekārta vai pārsegi ir marķēti ar labajā pusē esošo simbolu, skatiet operatora rokasgrāmatā ietvertos norādījumus. 
10. Visi šajā izstrādājumā izmantotie grafiskie simboli atbilst vienam vai vairākiem no šiem standartiem: EN61010-1, IEC417 un ISO3864.
11. Ja iekārtai vai uzlīmēm ir marķējums "Neatvērt, kamēr pieslēgta strāvai" vai tamlīdzīga norāde, tas nozīmē, ka sprādzienbīstamā vidē ir uzliesmošanas bīstamība. Šo iekārtu drīkst atvērt tikai tad, ja ir atvienota strāva un ir nogaidīts iekārtas atdzišanai nepieciešamais laiks, kas norādīts uzlīmē vai ekspluatācijas rokasgrāmatā, – un šos darbus drīkst veikt tikai atbilstoši apmācīti remontdarbu darbinieki.

**IMPORTANTI****STRUZZJONIJIET TAS-SIGURTÀ GĦALL-WIRING U L-INSTALLAZZJONI TAT-TAGĦMIR**



L-istruzzjonijiet tas-sigurtà japplikaw speċifikament għall-Istati Membri ta' l-UE. Dawn għandhom jiġu osservati b'mod strett biex tkun żgurata l-konformità mad-Direttiva dwar il-Vultaġġ Baxx. Stati li mhumiex membri ta' l-UE għandhom ukoll ikunu konformi ma' dan li ġej flief jekk dawn ikunu sostituti mill-Istandards lokali jew Nazzjonali.

1. Konnessjonijiet adegwati ta' l-ert għandhom isiru għall-punti kollha ta' l-ert, interni u esterni, fejn ikun ipprovdut.
2. Wara l-installazzjoni jew meta tipprova ssolvi xi problema, l-għatjien kollha tas-sigurtà u l-erts tas-sigurtà għandhom jitpoġġew lura f'posthom. L-integrità tat-terminali kollha ta' l-ert għandha tinżamm f'kull ħin.
3. Il-wajers tal-provvista tad-dawl għandhom ikunu konformi ml-ħtiġijiet ta' IEC227 jew IEC245.
4. Il-*wiring* kollu għandu jkun adattat għall-użu f'temperatura ta' l-ambjent ta' iktar minn 75°C.
5. Il-*glands* tal-kejbils kollha li jintużw iridu jkunu ta' daqs intern tali li jipprovdut ankoraġġ adegwat lill-kejbil.
6. Biex tiżgura t-ħaddim sigur ta' dan it-tagħmir, il-konnessjoni mal-provvista tad-dawl għandha ssir biss permezz ta' *circuit breaker* li jiskonnetta l-kondukturi kollha li jkunu jgħorru ċ-ċirkuwiti f'sitwazzjoni meta jkun hemm il-ħsara. Is-*circuit breaker* jista' wkoll jinkludi swiċċ li jiżola li jaħdem b'mod mekkaniku. Jekk dan ma jkunx il-każ, mezz ieħor ta' kif it-tagħmir jiġi skonnettjat minn mal-provvista tad-dawl għandu jkun ipprovdut, u jkun immrkat b'mod ċar li hu hekk. Is-*circuit breakers* jew swiċċijiet iridu jkunu konformi ma' standard rikonnoxxut bħal IEC947. Il-*wiring* kollu jrid ikun konformi ma' l-standards lokali, jekk ikun hemm.
7. Meta t-tagħmir jew l-għatjien ikunu mmarkati bis-simbolu fuq il-lemin, x'aktarx li jkun hemm vultaġġi perikolużi taħthom. Dawn l-għatjien għandhom jitneħħew biss meta titneħħa l-provvista tad-dawl mit-tagħmir - u minn ħaddiema tal-manutenzjoni mħarrġa biss. 
8. Meta t-tagħmir jew l-għatjien ikunu mmarkati bis-simbolu fuq il-lemin, ikun hemm periklu mill-uċuħ jaħarqu li jkun hemm taħthom. Dawn l-għatjien għandhom jitneħħew biss minn ħaddiema tal-manutenzjoni mħarrġa meta titneħħa l-provvista tad-dawl mit-tagħmir. Ċerti wċuħ jistgħu jibqgħu jaħarqu meta tmisshom. 
9. Meta t-tagħmir jew l-għatjien ikunu mmarkati bis-simbolu fuq il-lemin, irreferi għall-Manwal ta' l-Operatur għall-istruzzjonijiet.
10. Is-simboli grafici kollha użati f'dan il-prodott huma minn wieħed jew iktar mill-standards li ġejjin: EN61010-1, IEC417, u ISO3864. 
11. Fejn it-tagħmir u t-tikketti huma mmarkati bil-kliem "Tiftaħ Meta Jkun Energizzat" jew kliem simili, hemm periklu ta' nar f'żoni fejn atmosfera esplosiva hi preżenti. It-tagħmir għandu jinfetaħ biss meta l-provvista tad-dawl tkun mitfija u jkun għadda ħin biżżejjed, kif speċifikat fuq it-tikketta jew fil-manwal ta' l-istruzzjonijiet, biex it-tagħmir ikun kesaħ – u t-tagħmir għandu jinfetaħ biss minn staff li jkun imħarreg.

## **VIKTIG**

### **Sikkerhetsinstruks for tilkobling og installasjon av dette utstyret.**



**Følgende sikkerhetsinstruksjoner gjelder spesifikt alle EU medlemsland og land med i EØS-avtalen. Instruksjonene skal følges nøye slik at installasjonen blir i henhold til lavspenningsdirektivet. Den bør også følges i andre land, med mindre annet er spesifisert av lokale- eller nasjonale standarder.**

1. Passende jordforbindelser må tilkobles alle jordingspunkter, interne og eksterne hvor disse forefinnes.
2. Etter installasjon eller feilsøking skal alle sikkerhetsdeksler og jordforbindelser reetableres. Jordingsforbindelsene må alltid holdes i god stand.
3. Kabler fra spenningsforsyning skal oppfylle kravene spesifisert i IEC227 eller IEC245.
4. Alle ledningsforbindelser skal være konstruert for en omgivelsestemperatur høyere en 750°C.
5. Alle kabelforskruvninger som benyttes skal ha en indre dimensjon slik at tilstrekkelig avlastning oppnåes.
6. For å oppnå sikker drift og betjening skal forbindelsen til spenningsforsyningen bare skje gjennom en strømbryter (minimum 10A) som vil bryte spenningsforsyningen til alle elektriske kretser ved en feilsituasjon. Strømbryteren kan også inneholde en mekanisk operert bryter for å isolere instrumentet fra spenningsforsyningen. Dersom det ikke er en mekanisk operert bryter installert, må det være en annen måte å isolere utstyret fra spenningsforsyningen, og denne måten må være tydelig merket. Kretsbytere eller kontakter skal oppfylle kravene i en annerkjent standard av typen IEC947 eller tilsvarende.
7. Der hvor utstyr eller deksler er merket med symbol for farlig spenning, er det sannsynlig at disse er tilstede bak dekslet. Disse dekslene må bare fjernes når spenningsforsyning er frakoblet utstyret, og da bare av trent servicepersonell. 
8. Der hvor utstyr eller deksler er merket med symbol for meget varm overflate, er det sannsynlig at disse er tilstede bak dekslet. Disse dekslene må bare fjernes når spenningsforsyning er frakoblet utstyret, og da bare av trent servicepersonell. Noen overflater kan være for varme til å berøres i opp til 45 minutter etter spenningsforsyning frakoblet. 
9. Der hvor utstyret eller deksler er merket med symbol, vennligst referer til instruksjonsmanualen for instruksjer. 
10. Alle grafiske symboler brukt i dette produktet er fra en eller flere av følgende standarder: EN61010-1, IEC417 & ISO3864.
11. Når utstyr eller merkelapper bærer advarselen "Må ikke åpnes under spenning" eller lignende, innebærer det fare for eksplosjon i områder med en eksplosiv atmosfære. Utstyret skal bare åpnes når det ikke er noen strømtilførsel, og etter at det har hatt tilstrekkelig tid til å kjøle ned, som spesifisert på merkelappen eller i håndboken. Selv da skal utstyret bare åpnes av erfarne serviceteknikere.

## **WAŻNE!**

### **Zalecenia dotyczące bezpieczeństwa w zakresie podłączania i instalacji tego urządzenia**



**Następujące zalecenia dotyczą zwłaszcza stosowania urządzenia we wszystkich krajach Unii Europejskiej. Należy się ściśle do nich stosować w celu zapewnienia zgodności z dyrektywą niskonapięciową. W przypadku instalacji urządzenia w krajach nienależących do Unii Europejskiej należy również przestrzegać poniższych zaleceń, chyba że są one zastąpione lokalnymi lub ogólnokrajowymi standardami.**

1. Urządzenie należy podłączyć kablem uziemiającym do wszystkich punktów uziemienia (wewnętrznych i zewnętrznych).
2. Po instalacji lub czynnościach serwisowych należy zamknąć wszystkie pokrywy zabezpieczające i ponownie podłączyć uziemienie. Należy pilnować, by nie doszło do przerwania uziemienia.
3. Przewody zasilające powinny być zgodne z wymaganiami normy IEC227 lub IEC245.
4. Wszystkie przewody powinny być odpowiednie do użytku w środowisku o temperaturze wyższej niż 75°C.
5. Wszystkie dławnice powinny mieć wymiary wewnętrzne zapewniające pewne umocowanie przewodów.
6. W celu zapewnienia bezpiecznej pracy urządzenie należy podłączyć do sieci tylko za pośrednictwem wyłącznika automatycznego, który w razie awarii odłączy wszystkie obwody, w których przepływa prąd. Wyłącznik automatyczny może być również wyposażony w mechaniczny odłącznik napięcia. W przeciwnym razie należy zapewnić i jasno oznaczyć inną możliwość odłączenia urządzenia od zasilania. Wyłączniki automatyczne oraz odłączniki powinny być zgodne z uznawanymi standardami, takimi jak norma IEC947. Wszystkie przewody muszą być zgodne z lokalnymi przepisami.
7. Pod pokrywami lub elementami urządzenia oznaczonymi symbolem pokazanym na rysunku po prawej stronie może występować niebezpieczne napięcie elektryczne. Te pokrywy mogą być zdejmowane tylko po odłączeniu zasilania, wyłącznie przez odpowiednio przeszkolonych pracowników serwisu. 
8. Pod pokrywami lub elementami urządzenia oznaczonymi symbolem pokazanym na rysunku po prawej stronie znajdują się gorące powierzchnie. Te pokrywy mogą być zdejmowane tylko po odłączeniu zasilania, wyłącznie przez odpowiednio przeszkolonych pracowników serwisu. Niektóre powierzchnie mogą pozostać nagrzane przez pewien czas po odłączeniu zasilania. 
9. W przypadku sprzętu oraz pokryw oznaczonych symbolem pokazanym na rysunku po prawej stronie należy zapoznać się ze wskazówkami w Instrukcji operatora i stosować się do nich. 
10. Wszystkie symbole graficzne zastosowane do oznaczenia produktu pochodzą z następujących norm: EN61010-1, IEC417 lub ISO3864.
11. Oznaczenie „Nie otwierać, gdy urządzenie jest pod napięciem” lub podobne oznaczenia informują o ryzyku zapłonu w miejscach, gdzie występuje zagrożenie wybuchem. Urządzenie należy otwierać tylko po odłączeniu zasilania i po upływie czasu na ostygnięcie urządzenia oznaczonego na etykiecie lub w instrukcji obsługi. Urządzenie mogą otwierać wyłącznie odpowiednio przeszkoleni pracownicy serwisu.

## **IMPORTANTE**

### **Instruções de segurança para ligação e instalação deste aparelho.**



**As seguintes instruções de segurança aplicam-se especificamente a todos os estados membros da UE. Devem ser observadas rigidamente por forma a garantir o cumprimento da Directiva sobre Baixa Tensão. Relativamente aos estados que não pertençam à UE, deverão cumprir igualmente a referida directiva, exceptuando os casos em que a legislação local a tiver substituído.**

1. Devem ser feitas ligações de terra apropriadas a todos os pontos de terra, internos ou externos.
2. Após a instalação ou eventual reparação, devem ser recolocadas todas as tampas de segurança e terras de protecção. Deve manter-se sempre a integridade de todos os terminais de terra.
3. Os cabos de alimentação eléctrica devem obedecer às exigências das normas IEC227 ou IEC245.
4. Os cabos e fios utilizados nas ligações eléctricas devem ser adequados para utilização a uma temperatura ambiente até 75°C.
5. As dimensões internas dos buçins dos cabos devem ser adequadas a uma boa fixação dos cabos.
6. Para assegurar um funcionamento seguro deste equipamento, a ligação ao cabo de alimentação eléctrica deve ser feita através de um disjuntor (min. 10A) que desligará todos os condutores de circuitos durante uma avaria. O disjuntor poderá também conter um interruptor de isolamento accionado manualmente. Caso contrário, deverá ser instalado qualquer outro meio para desligar o equipamento da energia eléctrica, devendo ser assinalado convenientemente. Os disjuntores ou interruptores devem obedecer a uma norma reconhecida, tipo IEC947.
7. Sempre que o equipamento ou as tampas contiverem o símbolo, é provável a existência de tensões perigosas. Estas tampas só devem ser retiradas quando a energia eléctrica tiver sido desligada e por Pessoal da Assistência devidamente treinado. 
8. Sempre que o equipamento ou as tampas contiverem o símbolo, há perigo de existência de superfícies quentes. Estas tampas só devem ser retiradas por Pessoal da Assistência devidamente treinado e depois de a energia eléctrica ter sido desligada. Algumas superfícies permanecem quentes até 45 minutos depois. 
9. Sempre que o equipamento ou as tampas contiverem o símbolo, o Manual de Funcionamento deve ser consultado para obtenção das necessárias instruções. 
10. Todos os símbolos gráficos utilizados neste produto baseiam-se em uma ou mais das seguintes normas: EN61010-1, IEC417 e ISO3864.
11. Sempre que o equipamento ou as etiquetas apresentarem o aviso "Não abrir quando ligado à corrente" ou semelhante, existe um risco de ignição em atmosferas explosivas. Este equipamento só deve ser aberto depois de desligado da corrente eléctrica e o tempo de arrefecimento adequado especificado na etiqueta ou no manual de instruções ter decorrido. O equipamento só pode ser aberto por técnicos qualificados.

## DÔLEŽITÉ

### Bezpečnostné pokyny pre zapojenie káblov a inštaláciu tohto prístroja

Nasledovné bezpečnostné pokyny sa vzťahujú konkrétne na všetky členské štáty EÚ. Musia byť striktné dodržané, aby sa zaistila zhoda so Smernicou o nízkom napätí. Štáty, ktoré nie sú členskými štátmi EÚ by mali nasledovné pokyny taktiež dodržiavať, pokiaľ nie sú nahradené miestnymi alebo národnými normami.



1. Adekvátne uzemnenia musia byť vykonané na všetkých bodoch uzemnenia, interných aj externých, tam, kde sú poskytnuté.
2. Po inštalácii alebo riešení problémov musia byť všetky bezpečnostné kryty a bezpečnostné uzemnenia vymenené. Integrita všetkých uzemňovacích terminálov musí byť vždy zachovaná.
3. Káble sieťového napájania musia byť v zhode s požiadavkami IEC227 alebo IEC245.
4. Všetky káblové pripojenia by mali byť vhodné pre používanie v teplote okolia vyššej, ako 75°C.
5. Všetky použité káblové priechodky musia mať také vnútorné rozmery, aby poskytovali adekvátne uchopenie kábla.
6. Pre zaistenie bezpečnej prevádzky tohto zariadenia musí byť pripojenie k sieťovému napájaniu zapojené len cez prerušovač obvodu, ktorý počas poruchovej situácie odpojí všetky obvody elektrických vodičov. Prerušovač obvodu by mal obsahovať aj mechanicky ovládaný úsekový vypínač. Ak nie, musí byť poskytnutý iný spôsob odpojenia zariadenia od sieťového napájania a tento spôsob musí byť zreteľne označený. Prerušovače obvodu alebo spínače musia byť v zhode s uznanou normou, ako napr. IEC947. Všetky káblové pripojenia musia vyhovovať akýmkoľvek miestnym normám.
7. Tam, kde je zariadenie alebo kryty označené symbolom na pravej strane, sa pravdepodobne nachádza nebezpečné napätie. Tieto kryty by sa mali odoberať len vtedy, keď je zariadenie odpojené od elektrickej energie a len vyškoleným servisným personálom. 
8. Tam, kde je zariadenie alebo kryty označené symbolom na pravej strane, existuje nebezpečenstvo horúcich povrchov. Tieto kryty by mali byť odstraňované len vyškoleným servisným personálom, pričom je zariadenie odpojené od elektrickej energie. Určité povrchy môžu zostať horúce na dotyk. 
9. V miestach, kde je zariadenie alebo kryty označené symbolom na pravej strane, si kvôli pokynom pozrite Operátorskú príručku. 
10. Všetky obrázkové symboly použité pri tomto produkte zodpovedajú jednej alebo viacerým nasledujúcim normám: EN61010-1, IEC417 a ISO3864.
11. V miestach, kde je zariadenie alebo značky označené nápisom "Neotvárať pod elektrickým prúdom" alebo podobné, existuje nebezpečenstvo vznietenia v oblastiach s prítomnosťou výbušného ovzdušia. Toto zariadenie sa smie otvárať len v prípade odpojenia od elektrického napájania a ponechania zariadenia vychladnúť po dobu uplynutia dostatočného času tak, ako je to uvedené na štítku alebo v návode na použitie - a len vyškoleným servisným personálom.



## **POMEMBNO**

### **Varnostna navodila za povezavo in vgradnjo naprave**



**Naslednja varnostna navodila veljajo za vse države članice EU. Zaradi zagotovitve skladnosti z nizkonapetostno direktivo morate navodila strogo upoštevati. V državah, ki niso članice EU, je treba upoštevati tudi naslednje smernice, razen če jih ne zamenjujejo lokalni ali nacionalnimi standardi.**

1. Do vseh ozemljitvenih točk, notranjih in zunanjih, ki so na voljo, morajo biti speljane ustrezne ozemljitvene povezave.
2. Po vgradnji ali odpravljanju težav je treba namestiti vse varnostne pokrove in zaščitne ozemljitve. Brezhibnost vseh ozemljitvenih priključkov je treba nenehno preverjati.
3. Omrežni napajalni kabli morajo biti skladni z zahtevami standarda IEC227 ali IEC245.
4. Vsa napeljava mora biti primerna za uporabi pri temperaturi okolja, višji od 75 °C.
5. Notranje dimenzije kablskih tesnilk morajo zagotavljati ustrezno pritrditev kablov.
6. Za zagotovitev varnega delovanja opreme mora biti povezava z omrežnim napajanjem vzpostavljena prek odklopnega stikala, ki v primeru napake izklopi vse tokokroge s prevodniki. Odklopno stikalo lahko vključuje tudi mehansko izolacijsko stikalo. V nasprotnem primeru morajo biti zagotovljeni in jasno označeni drugi načini za izklop opreme iz napajanja. Odklopna in druga stikala morajo biti skladna z uveljavljenimi standardi, kot je IEC947. Vsa napeljava mora biti skladna z lokalnimi standardi.
7. V opremi ali pod pokrovi, ki so označeni s simbolom na desni, je prisotna nevarna napetost. Te pokrove je dovoljeno odstraniti samo, če je napajanje opreme izklopljeno. To lahko izvaja samo usposobljeno servisno osebje. 
8. Pri opremi ali pod pokrovi, ki so označeni s simbolom na desni, so prisotne nevarne vroče površine. Te pokrove lahko odstranjuje samo usposobljeno servisno osebje. Napajanje opreme mora biti izklopljeno. Določene površine so lahko vroče. 
9. Pri opremi ali pokrovih, ki so označeni s simbolom na desni, si za navodila oglejte priročnik za upravljanje. 
10. Vsi uporabljeni grafični simboli so iz enega ali več naslednjih standardov: EN61010-1, IEC417 in ISO3864.
11. Če je na opremi ali oznakah navedeno "Ne odpirajte, če je pod napetostjo" ali podobno opozorilo, je na območjih z eksplozivnim ozračjem prisotna nevarnost vžiga. To opremo je dovoljeno odpirati samo, če je napajanje izklopljeno in je poteklo dovolj časa, da se oprema ohladi, kot je navedeno na oznaki ali v priročniku z navodili. Opremo lahko odpira samo usposobljeno servisno osebje.

## **IMPORTANTE**

### **Instrucciones de seguridad para el montaje y cableado de este aparato.**



**Las siguientes instrucciones de seguridad, son de aplicacion especifica a todos los miembros de la UE y se adjuntaran para cumplir la normativa europea de baja tension.**

1. Se deben preveer conexiones a tierra del equipo, tanto externa como internamente, en aquellos terminales previstos al efecto.
2. Una vez finalizada las operaciones de mantenimiento del equipo, se deben volver a colocar las cubiertas de seguridad aasi como los terminales de tierra. Se debe comprobar la integridad de cada terminal.
3. Los cables de alimentacion electrica cumplan con las normas IEC 227 o IEC 245.
4. Todo el cableado sera adecuado para una temperatura ambiental de 75°C.
5. Todos los prensaestopas seran adecuados para una fijacion adecuada de los cables.
6. Para un manejo seguro del equipo, la alimentacion electrica se realizara a traves de un interruptor magnetotermico ( min 10 A ), el cual desconectara la alimentacion electrica al equipo en todas sus fases durante un fallo. Los interruptores estaran de acuerdo a la norma IEC 947 u otra de reconocido prestigio.
7. Cuando las tapas o el equipo lleve impreso el simbolo de tension electrica peligrosa, dicho alojamiento solamente se abra una vez que se haya interrumpido la alimentacion electrica al equipo asimismo la intervencion sera llevada a cabo por personal entrenado para estas labores. 
8. Cuando las tapas o el equipo lleve impreso el simbolo, hay superficies con alta temperatura, por tanto se abra una vez que se haya interrumpido la alimentacion electrica al equipo por personal entrenado para estas labores, y al menos se esperara unos 45 minutos para enfriar las superficies calientes. 
9. Cuando el equipo o la tapa lleve impreso el simbolo, se consultara el manual de instrucciones. 
10. Todos los simbolos graficos usados en esta hoja, estan de acuerdo a las siguientes normas EN61010-1, IEC417 & ISO 3864.
11. Cuando el equipo o las etiquetas tienen la indicación " No abrir mientras reciba energía" u otra similar, existe el peligro de ignición en zonas donde haya un ambiente explosivo. Este equipo sólo debe ser abierto por personal de servicio cualificado después de apagarlo y dejar pasar el intervalo de tiempo correspondiente indicado en la etiqueta o el manual de instrucciones para que el equipo se enfríe.

## **VIKTIGT**

**Säkerhetsföreskrifter för kablage och installation av denna apparat.**

**Följande säkerhetsföreskrifter är tillämpliga för samtliga EU-medlemsländer. De skall följas i varje avseende för att överensstämja med Lågspännings direktivet. Icke EU medlemsländer skall också följa nedanstående punkter, såvida de inte övergrips av lokala eller nationella föreskrifter.**

1. Tillämplig jordkontakt skall utföras till alla jordade punkter, såväl internt som externt där så erfordras.
2. Efter installation eller felsökning skall samtliga säkerhetshöljen och säkerhetsjord återplaceras. Samtliga jordterminaler måste hållas obrutna hela tiden.
3. Matningsspänningens kabel måste överensstämja med föreskrifterna i IEC227 eller IEC245.
4. Allt kablage skall vara lämpligt för användning i en omgivningstemperatur högre än 75°C.
5. Alla kabelförskruvningar som används skall ha inre dimensioner som motsvarar adekvat kabelförankring.
6. För att säkerställa säker drift av denna utrustning skall anslutning till huvudströmmen endast göras genom en säkring (min 10A) som skall frångöras alla strömförande kretsar när något fel uppstår. Säkningen kan även ha en mekanisk frånskiljare. Om så inte är fallet, måste ett annat förfarande för att frånskilja utrustningen från strömförsörjning tillhandahållas och klart framgå genom markering. Säkring eller omkopplare måste överensstämja med en gällande standard såsom t ex IEC947.
7. Där utrustning eller hölje är markerad med vidstående symbol föreligger risk för livsfarlig spänning i närheten. Dessa höljen får endast avlägsnas när strömmen ej är ansluten till utrustningen - och då endast av utbildad servicepersonal. 
8. När utrustning eller hölje är markerad med vidstående symbol föreligger risk för brännskada vid kontakt med uppvärmd yta. Dessa höljen får endast avlägsnas av utbildad servicepersonal, när strömmen kopplats från utrustningen. Vissa ytor kan vara mycket varma att vidröra även upp till 45 minuter efter avstängning av strömmen. 
9. När utrustning eller hölje markerats med vidstående symbol bör instruktionsmanualen studeras för information. 
10. Samtliga grafiska symboler som förekommer i denna produkt finns angivna i en eller flera av följande föreskrifter:- EN61010-1, IEC417 & ISO3864.
11. För utrustning som markerats med föreskrifter som "Öppna inte när strömmen är på", eller liknande, råder explosionsrisk när det förekommer explosiva ångor. Utrustningen får endast öppnas efter att strömmen stängts av och efter att utrustningen fått svalna under så lång tid som anges i instruktionsboken. Öppnandet får endast utföras av utbildad servicepersonal.

**SAFETY DATA SHEET  
FOR CERAMIC FIBER  
PRODUCTS****JULY 1, 1996****SECTION I. IDENTIFICATION****PRODUCT NAME**

Ceramic Fiber Heaters, Molded Insulation Modules and Ceramic Fiber Radiant Heater Panels.

**CHEMICAL FAMILY**

Vitreous Aluminosilicate Fibers with Silicon Dioxide.

**CHEMICAL NAME**

N.A.

**CHEMICAL FORMULA**

N.A.

**MANUFACTURER'S NAME AND ADDRESS**

Watlow Columbia  
2101 Pennsylvania Drive  
Columbia, MO 65202  
573-814-1300, ext. 5170  
573-474-9402

**HEALTH HAZARD SUMMARY WARNING**

- Possible cancer hazard based on tests with laboratory animals.
- May be irritating to skin, eyes and respiratory tract.
- May be harmful if inhaled.
- Cristobalite (crystalline silica) formed at high temperatures (above 1800°F) can cause severe respiratory disease.

**SECTION II. PHYSICAL DATA****APPEARANCE AND ODOR**

Cream to white colored fiber shapes. With or without optional white to gray granular surface coating and/or optional black surface coating.

**SPECIFIC WEIGHT: 12-25 LB./CUBIC FOOT**

**BOILING POINT: N.A.**

**VOLATILES (% BY WT.): N.A.**

**WATER SOLUBILITY: N.A.**

**SECTION III. HAZARDOUS INGREDIENTS**

**MATERIAL, QUANTITY, AND THRESHOLD/EXPOSURE LIMIT VALUES**

Aluminosilicate (vitreous) 99+ % 1 fiber/cc TWA

CAS. No. 142844-00-0610 fibers/cc CL

Zirconium Silicate 0-10% 5 mg/cubic meter (TLV)

Black Surface Coating\*\* 0 - 1% 5 mg/cubic meter (TLV)

Amorphous Silica/Silicon Dioxide 0-10% 20 mppcf (6 mg/cubic meter)

PEL (OSHA 1978) 3 gm cubic meter

(Respirable dust): 10 mg/cubic meter,

Intended TLV (ACGIH 1984-85)

\*\*Composition is a trade secret.

**SECTION IV. FIRE AND EXPLOSION DATA**

**FLASH POINT:** None

**FLAMMABILITY LIMITS:** N.A.

**EXTINGUISHING MEDIA**

Use extinguishing agent suitable for type of surrounding fire.

**UNUSUAL FIRE AND EXPLOSION HAZARDS / SPECIAL FIRE FIGHTING PROCEDURES**

N.A.

**SECTION V. HEALTH HAZARD DATA**

**THRESHOLD LIMIT VALUE**

(See Section III)

**EFFECTS OF OVER EXPOSURE**

- **EYE** - Avoid contact with eyes. Slightly to moderately irritating. Abrasive action may cause damage to outer surface of eye.
- **INHALATION** - May cause respiratory tract irritation. Repeated or prolonged breathing of particles of respirable size may cause inflammation of the lung leading to chest pain, difficult breathing, coughing and possible fibrotic change in the lung (Pneumoconiosis). Pre-existing medical conditions may be aggravated by exposure: specifically, bronchial hyper-reactivity and chronic bronchial or lung disease.
- **INGESTION** - May cause gastrointestinal disturbances. Symptoms may include irritation and nausea, vomiting and diarrhea.
- **SKIN** - Slightly to moderate irritating. May cause irritation and inflammation due to mechanical reaction to sharp, broken ends of fibers.

## **EXPOSURE TO USED CERAMIC FIBER PRODUCT**

Product which has been in service at elevated temperatures (greater than 1800°F/982°C) may undergo partial conversion to cristobalite, a form of crystalline silica which can cause severe respiratory disease (Pneumoconiosis). The amount of cristobalite present will depend on the temperature and length of time in service. (See Section IX for permissible exposure levels).

## **SPECIAL TOXIC EFFECTS**

The existing toxicology and epidemiology data bases for RCF's are still preliminary. Information will be updated as studies are completed and reviewed. The following is a review of the results to date:

## **EPIDEMIOLOGY**

At this time there are no known published reports demonstrating negative health outcomes of workers exposed to refractory ceramic fiber (RCF). Epidemiologic investigations of RCF production workers are ongoing.

1. There is no evidence of any fibrotic lung disease (interstitial fibrosis) whatsoever on x-ray.
2. There is no evidence of any lung disease among those employees exposed to RCF that had never smoked.
3. A statistical "trend" was observed in the exposed population between the duration of exposure to RCF and a decrease in some measures of pulmonary function. These observations are clinically insignificant. In other words, if these observations were made on an individual employee, the results would be interpreted as being within the normal range.
4. Pleural plaques (thickening along the chest wall) have been observed in a small number of employees who had a long duration of employment. There are several occupational and non-occupational causes for pleural plaque. It should be noted that plaques are not "pre-cancer" nor are they associated with any measurable effect on lung function.

## **TOXICOLOGY**

A number of studies on the health effects of inhalation exposure of rats and hamsters are available. Rats were exposed to RCF in a series of life-time nose-only inhalation studies. The animals were exposed to 30, 16, 9, and 3 mg/m<sup>3</sup>, which corresponds with approximately 200, 150, 75, and 25 fibers/cc.

Animals exposed to 30 and 16 mg/m<sup>3</sup> were observed to have developed a pleural and parenchymal fibroses; animals exposed to 9 mg/m<sup>3</sup> had developed a mild parenchymal fibrosis; animals exposed to the lowest dose were found to have the response typically observed any time a material is inhaled into the deep lung. While a statistically significant increase in lung tumors was observed following exposure to the highest dose, there was no excess lung cancers at the other doses. Two rats exposed to 30 mg/m<sup>3</sup> and one rat exposed to 9 mg/m<sup>3</sup> developed mesotheliomas.

The International Agency for Research on Cancer (IARC) reviewed the carcinogenicity data on man-made vitreous fibers (including ceramic fiber, glasswool, rockwool, and slagwool) in 1987. IARC classified ceramic fiber, fibrous glasswool and mineral wool (rockwool and slagwool) as possible human carcinogens (Group 2B).

**EMERGENCY FIRST AID PROCEDURES**

- **EYE CONTACT** - Flush eyes immediately with large amounts of water for approximately 15 minutes. Eye lids should be held away from the eyeball to insure thorough rinsing. Do not rub eyes. Get medical attention if irritation persists.
- **INHALATION** - Remove person from source of exposure and move to fresh air. Some people may be sensitive to fiber induced irritation of the respiratory tract. If symptoms such as shortness of breath, coughing, wheezing or chest pain develop, seek medical attention. If person experiences continued breathing difficulties, administer oxygen until medical assistance can be rendered.
- **INGESTION** - Do not induce vomiting. Get medical attention if irritation persists.
- **SKIN CONTACT** - Do not rub or scratch exposed skin. Wash area of contact thoroughly with soap and water. Using a skin cream or lotion after washing may be helpful. Get medical attention if irritation persists.

**SECTION VI. REACTIVITY DATA****STABILITY/CONDITIONS TO AVOID**

Stable under normal conditions of use.

**HAZARDOUS POLYMERIZATION/CONDITIONS TO AVOID**

N.A.

**INCOMPATIBILITY/MATERIALS TO AVOID**

Incompatible with hydrofluoric acid and concentrated alkali.

**HAZARDOUS DECOMPOSITION PRODUCTS**

N.A.

**SECTION VII. SPILL OR LEAK PROCEDURES****STEPS TO BE TAKEN IF MATERIAL IS RELEASED OR SPILLED**

Where possible, use vacuum suction with HEPA filters to clean up spilled material. Use dust suppressant where sweeping if necessary. Avoid clean up procedure which may result in water pollution. (Observe Special Protection Information Section VIII.)

**WASTE DISPOSAL METHODS**

The transportation, treatment, and disposal of this waste material must be conducted in compliance with all applicable Federal, State, and Local regulations.

## SECTION VIII. SPECIAL PROTECTION INFORMATION

### RESPIRATORY PROTECTION

Use NIOSH or MSHA approved equipment when airborne exposure limits may be exceeded. NIOSH/MSHA approved breathing equipment may be required for non-routine and emergency use. (See Section IX for suitable equipment).

Pending the results of long term health effects studies, engineering control of airborne fibers to the lowest levels attainable is advised.

### VENTILATION

Ventilation should be used whenever possible to control or reduce airborne concentrations of fiber and dust. Carbon monoxide, carbon dioxide, oxides of nitrogen, reactive hydrocarbons and a small amount of formaldehyde may accompany binder burn off during first heat. Use adequate ventilation or other precautions to eliminate vapors resulting from binder burn off. Exposure to burn off fumes may cause respiratory tract irritation, bronchial hyper-reactivity and asthmatic response.

### SKIN PROTECTION

Wear gloves, hats and full body clothing to prevent skin contact. Use separate lockers for work clothes to prevent fiber transfer to street clothes. Wash work clothes separately from other clothing and rinse washing machine thoroughly after use.

### EYE PROTECTION

Wear safety glasses or chemical worker's goggles to prevent eye contact. Do not wear contact lenses when working with this substance. Have eye baths readily available where eye contact can occur.

## SECTION IX. SPECIAL PRECAUTIONS

### PRECAUTIONS TO BE TAKEN IN HANDLING AND STORING

General cleanliness should be followed.

The Toxicology data indicate that ceramic fiber should be handled with caution. The handling practices described in this MSDS must be strictly followed. In particular, when handling refractory ceramic fiber in any application, special caution should be taken to avoid unnecessary cutting and tearing of the material to minimize generation of airborne dust.

It is recommended that full body clothing be worn to reduce the potential for skin irritation. Washable or disposable clothing may be used. Do not take unwashed work clothing home. Work clothes should be washed separately from other clothing. Rinse washing machine thoroughly after use. If clothing is to be laundered by someone else, inform launderer of proper procedure. Work clothes and street clothes should be kept separate to prevent contamination.

Product which has been in service at elevated temperatures (greater than 1800°F/982°C) may undergo partial conversion to cristobalite, a form of crystalline silica. This reaction occurs at the furnace lining hot face. As a consequence, this material becomes more friable; special caution must be taken to minimize generation of air-borne dust. The amount of cristobalite present will depend on the temperature and length in service.



IARC has recently reviewed the animal, human, and other relevant experimental data on silica in order to critically evaluate and classify the cancer causing potential. Based on its review, IARC classified crystalline silica as a group 2A carcinogen (probable human carcinogen).

The OSHA permissible exposure limit (PEL for cristobalite is 0.05 mg/m<sup>3</sup> (respirable dust). The ACGIH threshold limit value (TLV) for cristobalite is 0.05 mg/m<sup>3</sup> (respirable dust) (ACGIH 1991-92). Use NIOSH or MSHA approved equipment when airborne exposure limits may be exceeded. The minimum respiratory protection recommended for given airborne fiber or cristobalite concentrations are:

**CONCENTRATION**

Concentration	Personal Protective Equipment
0-1 fiber/cc or 0-0.05 mg/m <sup>3</sup> cristobalite (the OSHA PEL)	Optional disposable dust respirator (e.g. 3M 9970 or equivalent).
Up to 5 fibers/cc or up to 10 times the OSHA PEL for cristobalite	Half face, air purifying respirator equipped with high efficiency particulate air (HEPA) filter cartridges (e.g. 3M 6000 series with 2040 filter or equivalent).
Up to 25 fibers/cc or 50 times the OSHA PEL for cristobalite (2.5 mg/m <sup>3</sup> )	Full face, air purifying respirator with high efficiency particulate air (HEPA) filter cartridges (e.g. 3M 7800S with 7255 filters or equivalent) or powered air purifying respirator (PARR) equipped with HEPA filter cartridges (e.g. 3M W3265S with W3267 filters or equivalent).
Greater than 25 fibers/cc or 50 times the OSHA PEL for cristobalite (2.5 mg/m <sup>3</sup> )	Full face, positive pressure supplied air respirator (e.g. 3M 7800S with W9435 hose & W3196 low pressure regulator kit connected to clean air supply or equivalent).

If airborne fiber or cristobalite concentrations are not known, as minimum protection, use NIOSH/MSHA approved half face, air purifying respirator with HEPA filter cartridges.

Insulation surface should be lightly sprayed with water before removal to suppress airborne dust. As water evaporates during removal, additional water should be sprayed on surfaces as needed. Only enough water should be sprayed to suppress dust so that water does not run onto the floor of the work area. To aid the wetting process, a surfactant can be used.

After RCF removal is completed, dust suppressing cleaning methods, such as wet sweeping or vacuuming, should be used to clean the work area. If dry vacuuming is used, the vacuum must be equipped with HEPA filter. Air blowing or dry sweeping should not be used. Dust suppressing components can be used to clean up light dust.

Product packaging may contain product residue. Do not reuse except to reship or return Ceramic Fiber products to the factory.

# Oxymitter 4000

---

**Instruction Manual**

IM-106-340, Rev. 4.2

July 2008

## Appendix B Return of Material

### RETURNING MATERIAL

If factory repair of defective equipment is required, proceed as follows:

1. Secure a return authorization number from an Emerson Process Management Sales Office or representative before returning the equipment. Equipment must be returned with complete identification in accordance with Emerson Process Management instructions or it will not be accepted.

In no event will Emerson Process Management be responsible for equipment returned without proper authorization and identification.

2. Carefully pack defective unit in a sturdy box with sufficient shock absorbing material to ensure that no additional damage will occur during shipping.
3. In a cover letter, describe completely:
  - a. The symptoms from which it was determined that the equipment is faulty.
  - b. The environment in which the equipment has been operating (housing, weather, vibration, dust, etc.).
  - c. Site from which equipment was removed.
  - d. Whether warranty or nonwarranty service is requested.
  - e. Complete shipping instructions for return of equipment.
  - f. Reference the return authorization number.
4. Enclose a cover letter and purchase order and ship the defective equipment according to instructions provided in Emerson Process Management Return Authorization, prepaid, to:

Emerson Process Management  
RMR Department  
Daniel Headquarters  
11100 Britmore Park Drive  
Houston, TX 77041

If warranty service is requested, the defective unit will be carefully inspected and tested at the factory. If failure was due to conditions listed in the standard Rosemount Analytical warranty, the defective unit will be repaired or replaced at Emerson Process Management's option, and an operating unit will be returned to the customer in accordance with shipping instructions furnished in the cover letter.

For equipment no longer under warranty, the equipment will be repaired at the factory and returned as directed by the purchase order and shipping instructions.

# Oxymitter 4000

---

**Instruction Manual**

IM-106-340, Rev. 4.2

July 2008

# Index

## A

Alarm Contacts . . . . . 8-4  
Alarm Indications . . . . . 8-4  
Alarms, Corrective Actions . . . 8-5

## B

By-Pass Packages . . . . . 11-2

## C

Calibration . . . . . 2-6, 4-6, 6-3  
Calibration Gas Bottles 1-20, 11-5,  
11-6  
Calibration Handshake . . . . . 4-5  
Cell Replacement Kit . . . . . 9-17  
Configuration . . . . . 2-2  
    HART . . . . . 2-2, 4-2  
    Recommended . . . . . 2-6, 4-6

## D

Display, Error . . . . . 5-2, 6-1  
Display, Operating . . . . . 5-1, 6-1  
Display, Startup . . . . . 5-1, 6-1

## E

Electrical Noise . . . . . 8-3  
Electrostatic Discharge . . . . . 8-3  
Essential Instructions . . . . . i-i

## H

HART Communications . . . . . 7-1  
HART Handheld Communicator 11-1

## I

IMPS 4000 . . . . . 11-3  
Installation  
    Mechanical . . . . . 3-2

## K

Kit  
    Cell Replacement . . . . . 9-17  
    Probe Disassembly . . . . . 10-5

## L

Local Operator Interface . . . . . 6-1  
Logic I/O Mode . . . . . 4-5  
LOI Menu Tree . . . . . 6-4  
LOI, Lockout . . . . . 6-3

## M

Maintenance . . . . . 9-1  
Material Safety Data Sheet . . . A-24  
Membrane Keypad . . . . . 5-2  
Menu Tree  
    HART . . . . . 7-5  
    LOI . . . . . 6-4  
Menu Tree, LOI . . . . . 6-4

## P

Parts, Replacement . . . . . 10-1  
Power Up . . . . . 5-1  
Product Matrix . . . . . 1-18

## R

Reference Air . . . . . 5-2  
Replacement Parts . . . . . 10-1  
Returning Material . . . . . B-1

## S

Service . . . . . 9-1  
Specifications . . . . . 1-16  
SPS 4001B . . . . . 11-4  
System Configuration . . . . . 1-4  
System Description . . . . . 1-3  
System Features . . . . . 1-6

## T

Troubleshooting . . . . . 8-1

# Oxymitter 4000

**Instruction Manual**

IM-106-340, Rev 4.2

July 2008

---

## WARRANTY

Rosemount Analytical warrants that the equipment manufactured and sold by it will, upon shipment, be free of defects in workmanship or material. Should any failure to conform to this warranty become apparent during a period of one year after the date of shipment, Rosemount Analytical shall, upon prompt written notice from the purchaser, correct such nonconformity by repair or replacement, F.O.B. factory of the defective part or parts. Correction in the manner provided above shall constitute a fulfillment of all liabilities of Rosemount Analytical with respect to the quality of the equipment.

**THE FOREGOING WARRANTY IS EXCLUSIVE AND IN LIEU OF ALL OTHER WARRANTIES OF QUALITY WHETHER WRITTEN, ORAL, OR IMPLIED (INCLUDING ANY WARRANTY OF MERCHANTABILITY OF FITNESS FOR PURPOSE).**

The remedy(ies) provided above shall be purchaser's sole remedy(ies) for any failure of Rosemount Analytical to comply with the warranty provisions, whether claims by the purchaser are based in contract or in tort (including negligence).

Rosemount Analytical does not warrant equipment against normal deterioration due to environment. Factors such as corrosive gases and solid particulates can be detrimental and can create the need for repair or replacement as part of normal wear and tear during the warranty period.

Equipment supplied by Rosemount Analytical Inc. but not manufactured by it will be subject to the same warranty as is extended to Rosemount Analytical by the original manufacturer.

At the time of installation it is important that the required services are supplied to the system and that the electronic controller is set up at least to the point where it is controlling the sensor heater. This will ensure, that should there be a delay between installation and full commissioning that the sensor being supplied with ac power and reference air will not be subjected to component deterioration.

# Oxymitter 4000

Oxymitter 4000
Part no. _____
Serial no. _____
Order no. _____

*Rosemount Analytical and the Rosemount Analytical logotype are registered trademarks of Rosemount Analytical Inc.  
HART is a registered trademark of the HART Communications Foundation.  
All other marks are the property of their respective owners.*

## WORLD HEADQUARTERS

**Emerson Process Management  
Rosemount Analytical Inc.**  
6565P Davis Industrial Parkway  
Solon, OH 44139  
T 440 914 1261  
T 800 433 6076  
F 440 914 1262  
E gas.csc@emersonprocess.com

## ROSEMOUNT ANALYTICAL EUROPE

**Emerson Process Management**  
GmbH & co. OHG  
Industriestrasse 1  
63594 Hasselroth  
Germany  
T 49 6055 884 0  
F 49 6055 884 209

## EUROPE, MIDDLE EAST, AFRICA

**Emerson Process Management**  
Shared Services Limited  
Heath Place  
Bognor Regis  
West Sussex PO22 9SH  
England  
T 44 1243 863121  
F 44 1243 845354

## GAS CHROMATOGRAPHY CENTER AND LATIN AMERICA

**Emerson Process Management  
Rosemount Analytical Inc.**  
11100 Brittmoore Park Drive  
Houston, TX 77041  
T 713 467 6000  
F 713 827 3329

## ASIA-PACIFIC

**Emerson Process Management**  
Asia Pacific Private Limited  
1 Pandan Crescent  
Singapore 128461  
Republic of Singapore  
T 65 6 777 8211  
F 65 6 777 0947  
E analytical@  
ap.emersonprocess.com

<http://www.raihome.com>