

Oxymitter 4000

In Situ Oxygen Transmitter

- Outstanding accuracy
- Electronics mounted to probe or separate
- Optional Xi advanced electronics
 - large backlit LCD display
 - advanced software features
 - Wireless - via THUM Adaptor
- Adaptable to any existing O2 probe installation
- Advanced sensor diagnostics
 - alarm indicates when calibration is recommended
- Optional explosion-proof ratings
- Digital HART® or FOUNDATION™ fieldbus communications
 - AMS/PlantWeb® compatible
- Fully field-repairable
- Variable probe insertion option



THE LATEST BREAKTHROUGH FOR COMBUSTION FLUE GAS ANALYSIS

The Oxymitter In Situ Oxygen Transmitter was the world's first in situ, zirconium oxide-based oxygen transmitter for flue gas measurement. These oxygen measurements can be used in a control system or by a boiler operator to fine tune burner fuel/air ratios for maximum efficiency. Ideal for:

- boilers
- kilns
- process heaters
- reheat furnaces

Emerson is the leader in oxygen flue gas analyzer technology. Our in situ, zirconium oxide oxygen analyzers have long been established as industry standards. We've combined our expertise with the latest Rosemount transmitter technology to create a truly revolutionary package – the Oxymitter.

The Oxymitter integrates an oxygen probe and field electronics into a single, compact package. The probe inserts directly into a flue gas duct to measure oxygen in combustion processes. No sampling system is required.

A NEMA 4X, IP 66 Rosemount transmitter housing mounts directly to the probe and contains the transmitter's electronics, replacing common stand-alone field electronics. This integrated design minimizes the costs of installing separate probe cable, conduit and electronics.

The Oxymitter electronics also require 95% less power to operate. So, its components last longer. Traditional architecture with remote-mounted electronics is also offered.

The HART® protocol provides a link into Emerson's PlantWeb® field-based architecture. Instrument technicians can interface with the Oxymitter from the control room or any location where the transmitter's signal wires terminate. Service diagnostics and calibrations can be performed remotely with a HART hand-held communicator or a personal computer equipped with AMS.

The Oxymitter is fully field-repairable. The probe's design provides convenient access to internal probe components so technicians can service the unit in house. The cell and heater/thermocouple are fully field-replaceable. The Oxymitter contains no potentiometer adjustments or jumpers.

The Oxymitter In Situ Oxygen Transmitter operates at process temperatures up to 1300°F (700°C), providing a fast response with high accuracy and reliability. Available lengths from 18 inches to 18 feet.

Optional accessories for the Oxymitter include:

- auto calibration gas sequencer
- remote, loop-powered Vacuum Fluorescent display of oxygen reading
- high temperature accessories for temperatures up to 1832°F (1000°C)
- flame arrestor
- abrasive shield

VARIABLE INSERTION OPTION

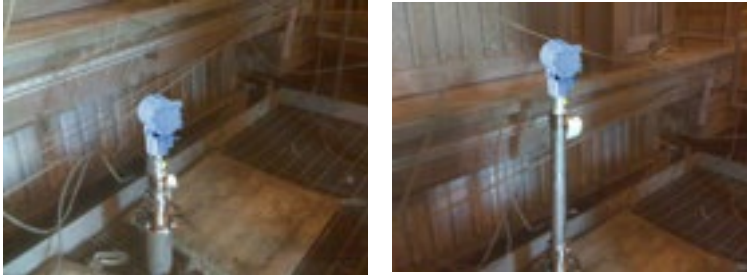

The new variable insertion option permits ideal placement of the probe into the flue gas duct. Probe can be adjusted at any time on-line to characterize stratification across large ducts.

THE OXYMITTER OXYGEN TRANSMITTER IS COMPLETELY FIELD-REPAIRABLE



Diffusion Filter and Sensor Cell Assembly

- Outstanding accuracy– + or - .75% of reading or .05% O₂
- Special cells for tough service in SO₂ and HCL
- Rugged steel cell holder – cells will not crack

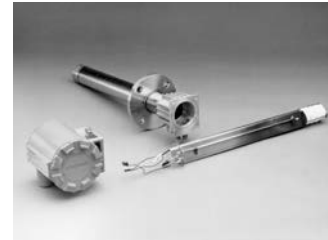

Heater/Thermocouple Assembly

General Purpose – OXT4A



- Lengths from 18" (.9m) to 18' (5.5m)
- ANSI, DIN and special flanges (1.8m) (5.5m)
- Flat-faced (snubber), Hastelloy and Ceramic Diffusers

Electronics

- -40°F to 185°F(-40°C to 70°C) ambient temperature limit
- HART or FOUNDATION™ Fieldbus communications
- "Calibration Recommended" diagnostic

Integral to Probe or Remote Mounted



- Lowest cost of installation
- Bright gas fluorescent local operator interface (LOI)
- Thru-glass infrared pushbuttons are suitable for hazardous areas

Xi Enhanced Interface



- Easy-to-read backlit display
- Easy-to-use keypad
- IP66 (NEMA 4X) enclosure
- Advanced software features
- Loss of flame relay option turns heater off upon flame loss

Advanced Features

Automatic Calibration - available with Oxymitter or Xi electronics

Plant personnel often ask how frequently an oxygen analyzer requires calibration. The answer is very application-dependent based upon the fuels being burned, normal levels of oxygen and the sulfur content in the flue gases. The X-STREAM Xi addresses this concern by providing an on-line diagnostic that determines when a calibration should be conducted, eliminating many unneeded calibrations and the technician and gas resources they consume. The X-STREAM electronics has an on-line impedance measurement for the sensing cell.

This feature can trigger a fully automatic calibration by sequencing solenoids to introduce calibration gases to the sensing cell. The Single Probe Sequencer (SPS) switches CAL gases to a single probe, while a Multi-Probe Sequencer (IMPS) can handle 1 to 4 probes. Many needless calibrations based on "time in service" are eliminated. A contact closure notifies the control room when a calibration is taking place. The oxygen output signal can be held at its last value, or released during calibration. The X-STREAM can also initiate calibrations by traditional methods:

- Contact closure from the user's control room
- Time since last calibration feature – established by the autocalibration system
- Xi enhanced interface
- HART/AMS

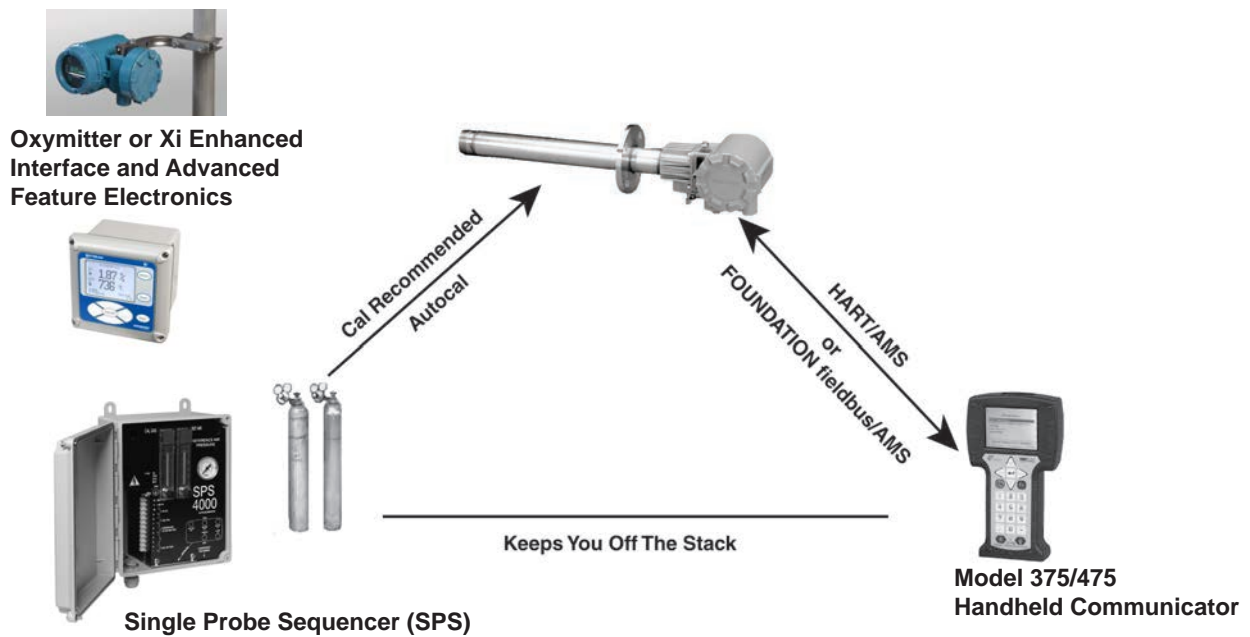

Optional Wireless THUM Adaptor
Transmit the O₂ signal, along with all HART information.



Advanced Software features (available only with the Xi electronics)

Extended Process Temperature Range to 800°C (1562°F)

The X-STREAM oxygen analyzer employs a heater and thermocouple to maintain a temperature setpoint at 736°C (1357°F). Temperature control is maintained within $\pm 1^\circ\text{C}$ to process temperatures of about 705°C (1300°F). This is satisfactory for most applications, but excursions to higher temperatures can occur in many processes. In these instances, the heater is turned off and the process temperature is utilized to heat the sensing cell.

Stoichiometer

Process upsets can sometimes cause a combustion process to go into substoichiometric or reducing conditions. The oxygen readings from one or more probes may decline all the way to zero. The stoichiometer cell will measure the amount of oxygen deficiency during these reducing conditions. The trends in your DCS can be set up for a lower range limit of -1 or -2% oxygen to depict the level of oxygen deficiency.

The operator can see if his control actions to recover are having the desired effect. These types of events do not occur frequently, but knowing the parameters of the situation prevents overcorrecting while coming out of the reducing condition.

The oxygen reading is adjusted immediately to compensate for the varying process temperatures. It should be noted that cell life will be reduced by continuous operation at temperatures above 705°C (1300°F). If process temperatures are expected to continuously be above 705°C, we recommend the use of a bypass or probe mounting jacket accessory (see page 10).



Acid-Resistant Stoichiometer Cell

Typical DCS Trend During a Reducing Process Event

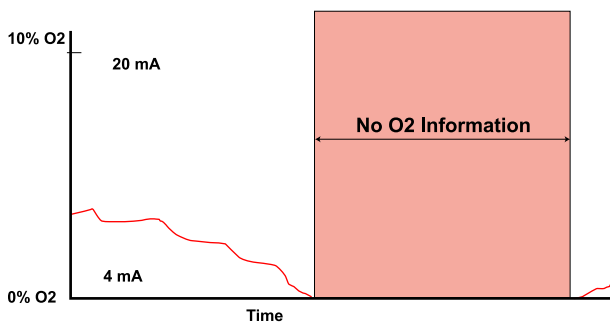

DCS Trend With X-STREAM Stoichiometer Feature

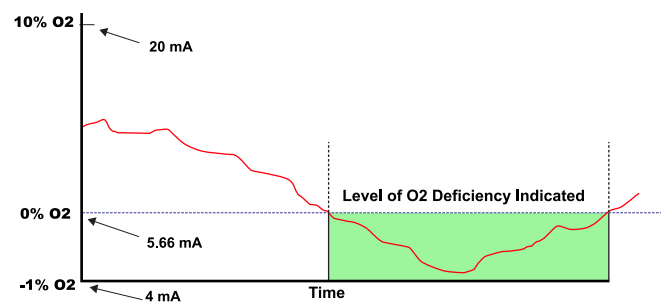

Programmable Reference

The zirconium oxide sensing technology has historically measured process oxygen by using ambient or instrument air as a reference (20.95% oxygen). The sensor develops most of its signal at the low oxygen levels typically found in combustion flue gases (2-4% oxygen) and is most accurate at these levels. When measuring at levels near ambient, however, the sensor develops only a few millivolts of signal and accuracy degrades.

The programmable reference feature permits the user to use a bottled reference gas of low oxygen value (.4% oxygen recommended). When measuring at or near 21% oxygen, a strong negative oxygen signal results with much improved accuracy. A bottle of reference gas typically lasts about a month at the low flows required.

Typical applications include:

Flue Gas Recirculation – controlling the mixing of flue gases into the burner windbox prior to the burner to reduce NOx emissions.

Moisture Monitoring – measuring the amount of moisture coming off of industrial dryers by noting the dilution effect water vapor has on the normal 20.95% ambient drying air.

Enriched Oxygen Combustion – Pure oxygen is sometimes mixed in with the combustion air to increase heat at the flame. This is used in steel and other metals reduction processes and also in some catalyst regenerators.

SPECIFICATIONS ¹

Measurement Specifications

Net O₂ Range: variable 0-10% to 0-40%
(Xi electronics offer 0-50% O₂ range)

Accuracy in Oxidizing conditions: ±0.75% of reading or 0.05% O₂, whichever is greater

Lowest detectable limit— .02% O₂

Process Temperature Effect— less than .05% O₂ from 100-700°C

System Speed of Response to Calibration Gas:

Initial response in less than 3 seconds, T90 in less than 8 seconds. Response to process gas changes will vary, depending on process gas velocity and particulate loading of the diffuser

Calibration Validity: Presentation of calibration gases matches the normal process to within ±.02% O₂

Accuracy in reducing conditions: ±.10% of reading, or .1% O₂, whichever is greater

System Response in Reducing Conditions: going from oxidizing to reducing -T90 in 120 sec.
going from reducing to oxidizing -T90 in 30 sec.

Environmental Specifications

Transmitter Probe: Process-wetted materials are 316L or 304 stainless steel

Process Temperature Limits: 0 to 705°C (32-1300°F) with Oxymitter electronics
0 to 800°C (32-1472°F) with Xi electronics
*reduced cell life can be expected if operated continuously at temperatures above 705°C (1300°F) optional bypass and jacket accessories permit operation to 1050°C (1922°F)

Oxymitter Transmitter Electronics Housing (integral to probe, or remote mounted): Low copper aluminum IP 66 (NEMA 4X), with reference air exhaust port piped to clean area

General Purpose Certifications: 

Oxymitter electronics ambient temp. Limits: -40° to 80°C (-40° to 176°F)

Temperature limit as measured inside Oxymitter electronics: -40° to 85°C (-40° to 185°F)

Temperature limit of see-thru IR pushbuttons: -40° to 70°C (-40° to 158°F)

Optional Xi Electronics: NEMA 4X, Polycarbonate Material

General Purpose Certifications:



Xi Ambient Temp. Limits: -20° to 55°C (-4° to 131°F)

Xi Temp. Limits as measured inside the housing: -20° to 55°C (-4° to 113°F)

Xi LCD display Temp. Limits: -20° to 55°C (-4° to 131°F)

Installation Specifications

Probe Mounting

Flange: vertical or horizontal — 2" 150# (4.75" (121mm) bolt circle)
DIN (145mm (5.71") bolt circle)

Note: flanges are flat-faced, and for mounting only. Flanges are not pressure-rated.

Spool piece P/N 3D39761G02 is available, to offset electronics housing from hot ductwork.

Many adaptor flanges are available to mate to existing flanges.

Probe Lengths and Approximate Shipping weights:

18 in. (457 mm) package:	16 pounds (7.3 kg)
3 foot (0.91 m) package:	21 pounds (9.5 kg)
6 foot (1.83 m) package:	27 pounds (12.2 kg)
9 foot (2.74 m) package:	33 pounds (15.0 kg)
12 foot (3.66 m) package:	39 pounds (17.7 kg)
15 foot (4.6 m) package:	45 pounds (20.5 kg)
18 foot (5.5 m) package:	51 pounds (23 kg)

Reference Air (optional): 2 scfh (1l/m), clean, dry, instrument quality air (20.95% O₂), regulated to 2.5 psi (34kPa)

Calibration: Semi-automatic or automatic

Cal Gases: .4% O₂ and 8%, balance N₂ recommended

Cal Gas Flow: 5 scfh (2.5 l/m)

Heater Electrical Power: 100 - 240V, ±10% 50/60 Hz 1/2" — 14" NPT conduit ports

Traditional Architecture Cable: 200 foot (61m) maximum length

Power Consumption of Probe Heater: 776VA maximum during warm-up

Electrical Power of Oxymitter or optional Xi electronics: 120 to 240V, ±10% 50/60 Hz

Power Consumption of Xi: 10 watts maximum

Xi Alarms Relays: 2 provided - 2 amps, 30 VDC

Xi Optional Loss of Flame Contact: Removes heater power

Electrical Noise:

Meets EN 61326, Class A

Traditional Architecture

Cable: 200ft (61m) maximum length

Power Consumption of Probe Heater: 776VA maximum during warm-up

Transmitter Electrical Power: 12 – 42VDC, (loop-powered from the control room or from the Xi box)

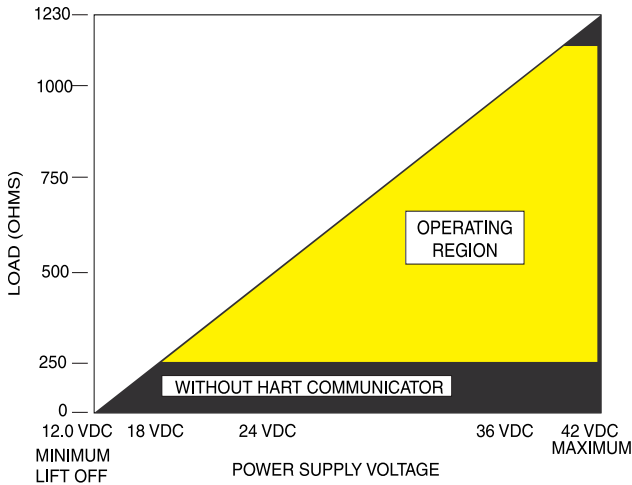

Power Supply and Load Requirements

Electrical Power for Xi:

100-240V ±10%, 50-60Hz

Power Consumption of Xi:

12VA maximum or
776VA maximum with Traditional Architecture, 120V, Probes.
450VA maximum with Traditional Architecture, 44V Probes

Alarm Relay Outputs: Two provided - 2 Amperes, 30 VDO, Form-C

Optional Loss of Flame Input: internally powered input to remove heater power, actuated via dry contact output from prove of flame device.

Emerson has satisfied all obligations coming from the European legislation to harmonize the product requirements in Europe.

¹ All static performance characteristics are with operating variables constant. Specifications subject to change without notice.



General Purpose

HART communications - OXT4A	pg. 11
FOUNDATION	
Fieldbus Communications - OXT5A	pg. 13
Direct Replacement Probe (for use with existing electronics) - OXT4ADR	pg. 15
Automatic calibration systems - XSO ₂ Cal	pg. 16
Optional Xi advanced electronics - Xi	pg. 17

OUTLINE DIMENSIONS FOR OXYMITTER OXYGEN TRANSMITTER FOR GENERAL PURPOSE APPLICATIONS (OXT4A, OXT5A, OXT4ADR)

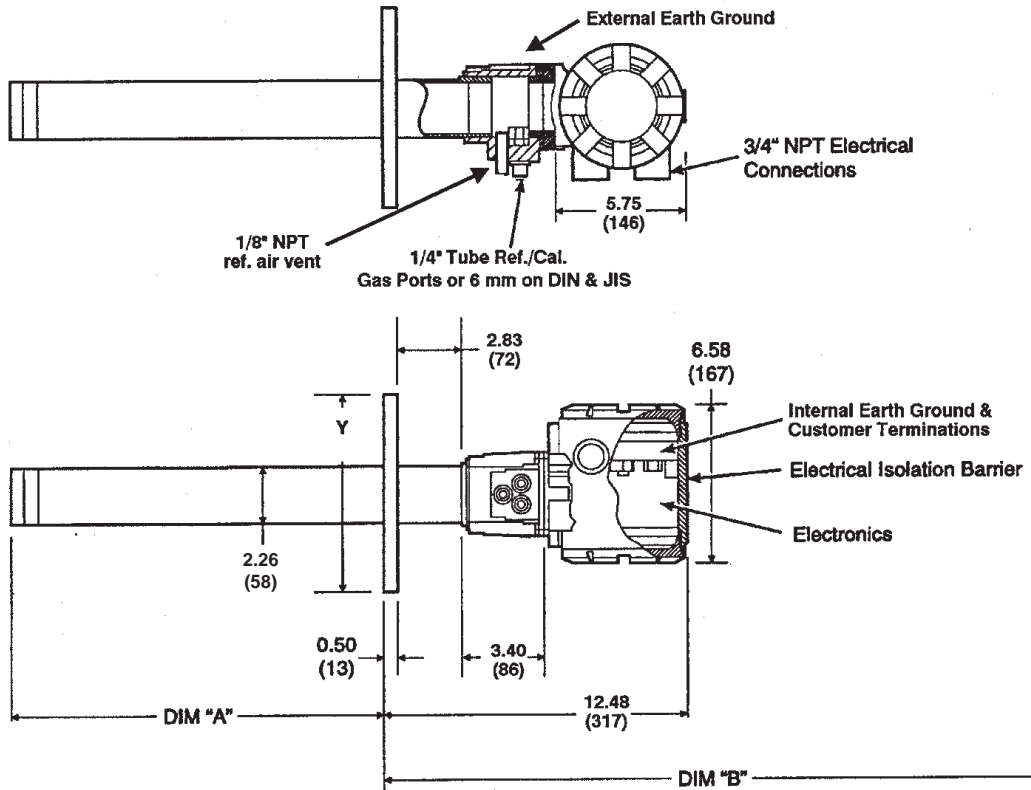

Note: All dimensions are in inches with millimeters in parentheses.

Adapter Plate Outline

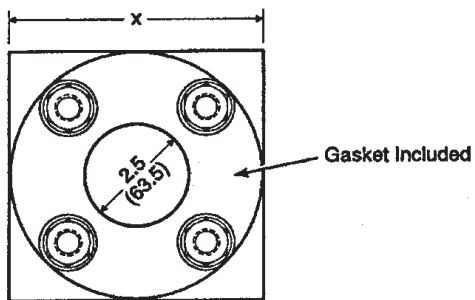

Refer to Table 1 for dimensions.

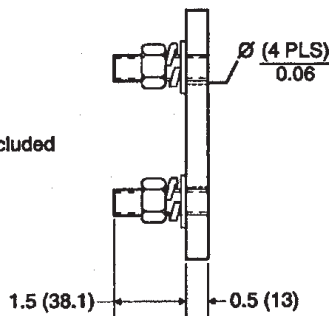

Table I. Mounting Plate

	Dimensions Dia. in. (mm)		
	ANSI	DIN	JIS
Mtg. Plate (x)	6.0 (153)	7.5 (190)	6.5 (165)
Stud Size	5/8" – 11	M16 x 2	M12 x 1.75
4 Studs Eq. Sp. on BC	4.75 BC (121) BC	5.71 BC (145) BC	5.12 BC (130) BC
Flange (Y)	6.0 (153)	7.3 (185)	6.1 (155)

Table II. Removal/Installation

Probe Length	Dim "A" Insertion Depth	Dim. "B" Removal Envelope
18 in. (457 mm) Probes	16.00 (407)	28.6 (725)
3 ft. (0.91 m) Probes	34.00 (864)	46.6 (1182)
6 ft. (1.83 m) Probes	70.00 (1778)	82.6 (2097)
9 ft. (0.91 m) Probes	106.00 (2692)	118.6 (3011)
12 ft. (3.66 m) Probes	142.00 (3607)	154.6 (3926)

OXYMITTER 4000 WITH ABRASIVE SHIELD

- Notes:**
1. These flat-faced flanges are manufactured to ANSI, and DIN bolt patterns and are not pressure rated.
 2. Dimensions are in inches with millimeters in parentheses.

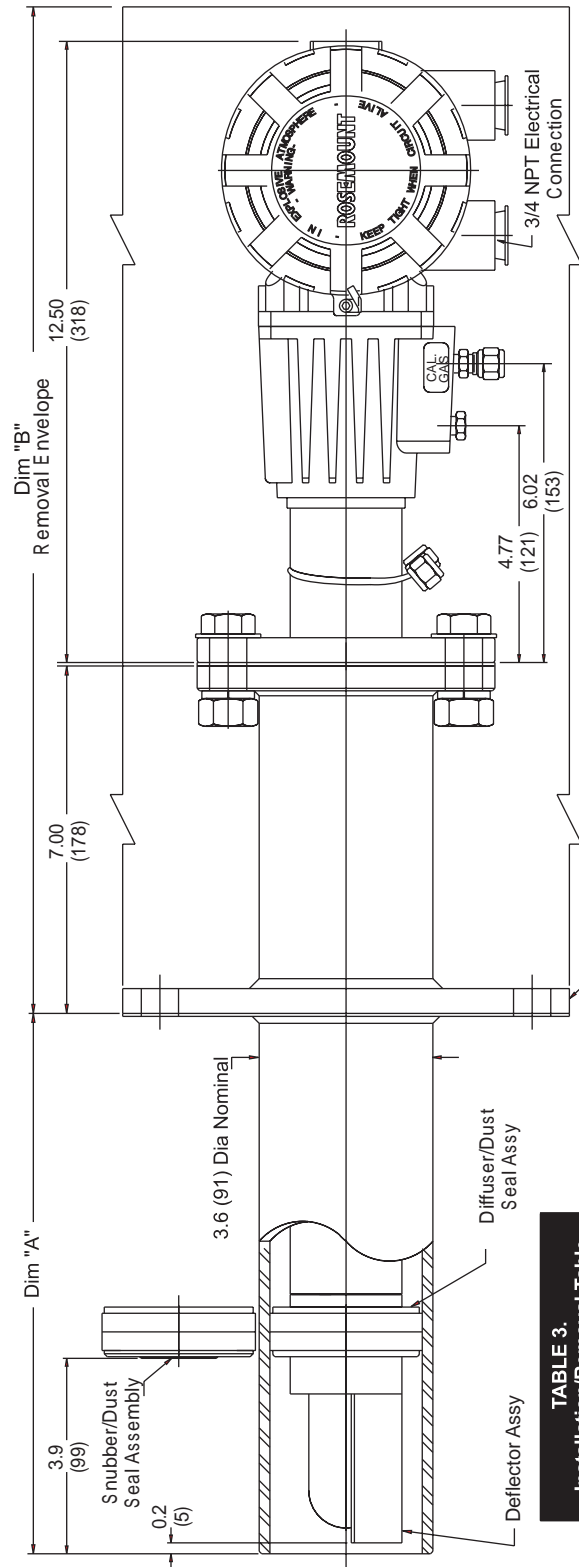

Cal Gas*	
Ref Air	
ANSI	1/4 in. Tube
DIN	6 mm Tube

*Add check valve in Cal Gas line

TABLE 4. Abrasive Shield -3D39003		
Flange	ANSI	DIN
Flange Dia	9.00 (229)	9.25 (235)
Hole Dia	0.75 (19)	0.94 (24)
(8) Holes Eq Sp on BC	7.50 (190)	7.48 (190)

TABLE 3. Installation/Removal Table		
Probe	Dim "A"	Dim "B"
18 in.	13 (330)	32.5 (826)
3 ft	31 (787)	50.5 (1283)
6 ft	67 (1702)	86.5 (2197)
9 ft	103 (2616)	122.5 (3112)
12 ft	139 (3531)	158.5 (4026)
15 ft	175 (4445)	194.5 (4940)
18 ft	211 (5359)	230.5 (5855)

Note: For probes 9 ft. or longer, bracing for cell end of probe is required inside the flue gas ductwork. (Brackets provided with abrasive shield)

OXYMITTER 4000 ADAPTOR PLATE WITH ABRASIVE SHIELD

TABLE 6. ADAPTER PLATE* DIMENSIONS FOR OXYMITTER 4000 WITH ABRASIVE SHIELD		
Dimensions in. (mm)	ANSI (P/N 3535B58G02)	DIN (P/N 3535B58G06)
"A"	9.00 (229)	9.25 (235)
"B" Dia	4.75 (121)	3.94 (100)
"C" Thread	0.625-11	(M-16 x 2)
"D" Dia	7.50 (191)	7.48 (190)

*Part numbers for adapter plates include attaching hardware.

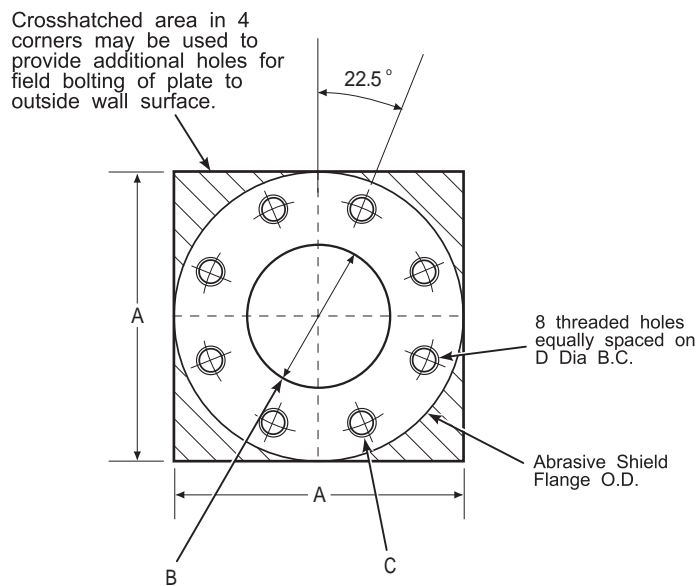

OPTIONAL VARIABLE INSERTION MOUNTING* (OXT4A, OXT5A, OXT4ADR)

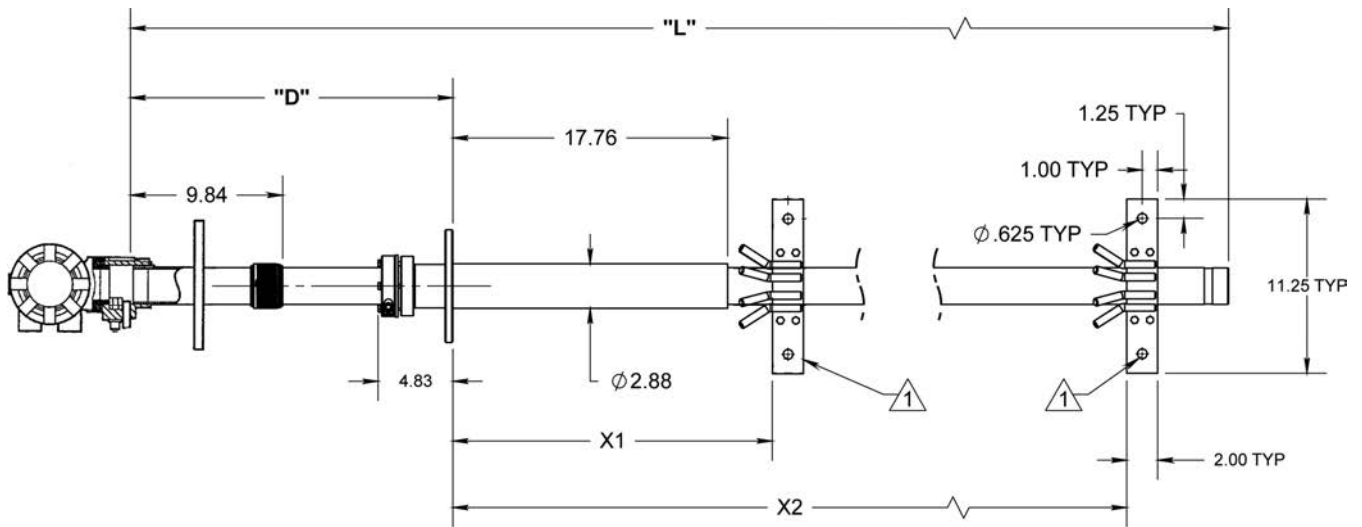

PROBE SIZE	L	D	X1 ±2 (51)	X2 ±2 (51)
9 ft. (2.73)	118 (2997)	18 (457) < D < 103 (2616)	72 (1829)	—
12 ft. (3.64)	154 (3912)	18 (457) < D < 139 (3531)	60 (1524)	120 (3948)
15 ft. (4.55)	190 (4826)	18 (457) < D < 175 (4445)	70 (1778)	150 (3810)
18 ft. (5.45)	226 (5740)	18 (457) < D < 211 (5359)	80 (2032)	160 (4064)

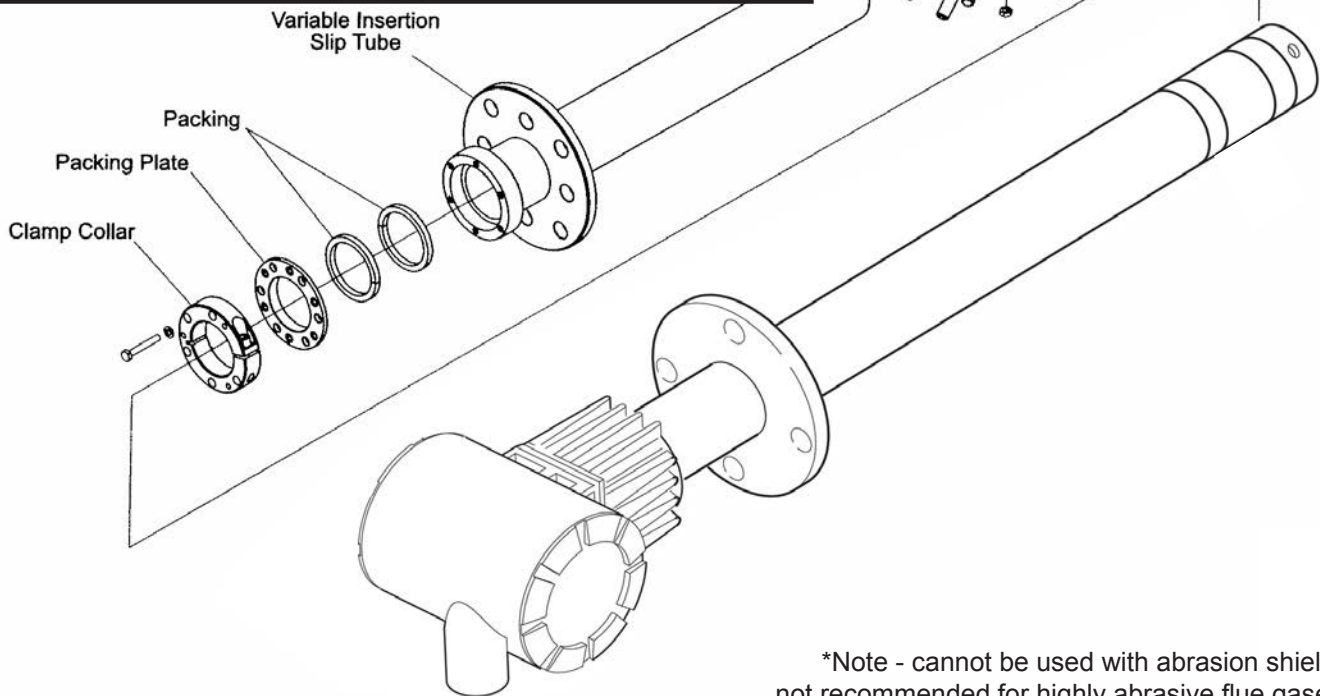
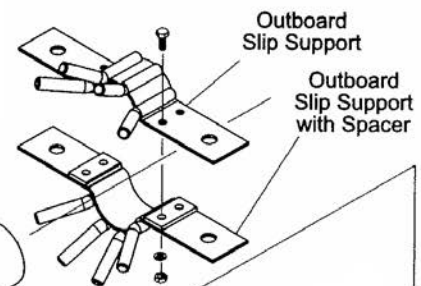

*Note - cannot be used with abrasion shield, not recommended for highly abrasive flue gases order by part #6A00319G03

ORDERING INFORMATION – General Purpose Oxymitter with 4-20 mA Output Signal, and HART® Communications. Optional Xi electronics not applicable.

Model	Description
OXT4A	In Situ Oxygen Transmitter – HART® Smart (Oxymitter 4000)

Level	1	Sensing Probe Type
	1	Ceramic diffusion element probe (ANSI)
	3	Snubber diffusion element (ANSI)
	4	Ceramic diffusion element probe (DIN)
	6	Snubber diffusion element (DIN)
	7	Ceramic diffusion element probe (JIS)
	9	Snubber diffusion element (JIS)

Level	2	Probe Assembly
	0	18" (457mm) probe
	1	18" (457mm) probe with abrasive shield
	2	3' (0.91m) probe
	3	3' (0.91m) probe with abrasive shield
	4	6' (1.83m) probe
	5	6' (1.83m) probe with abrasive shield
	6	9' (2.74m) probe
	7	9' (2.74m) probe with abrasive shield
	8	12' (3.66m) probe
	9	12' (3.66m) probe with abrasive shield
	A	15' (4.57m) probe with abrasive shield
	B	18' (5.49m) probe with abrasive shield

Level	3	Mounting Hardware (stack side)
	0	No mounting hardware
	1	New Installation – square weld plate with studs
	2	Mounting to Model 218 mounting plate (with Model 218 shield removed)
	3	Mounting to existing Model 218 support shield
	4	Mounting to other mounting
	5	Mounting to Model 132 adapter plate

Level	4	Mounting Hardware (probe side)
	0	No mounting hardware
	1	Probe only (ANSI)
	2	New bypass or new abrasive shield (ANSI)
	4	Probe only (DIN)
	5	New bypass or new abrasive shield (DIN)
	7	Probe only (JIS)
	8	New bypass or new abrasive shield (JIS)

Level	5	Electronic Housing and Filtered Customer Termination – NEMA 4X, IP 66
	12	For HART® electronics integrally mounted to probe with transient protected filtered termination – no cable required
	14	For HART® electronics mounted remotely with transient protected filtered termination – must select cable below

Level	6	Communications
	1	Membrane keypad – HART capable, blind cover
	2	Membrane keypad – HART capable, glass cover
	3	Gas fluorescent LOI HART capable, glass cover, English only

ORDERING INFORMATION (continued)

Level 7 Language	
1	English
2	German
3	French
4	Spanish
5	Italian

Level 8 Termination Filtering	
00	Specified as part of electronic housing

Level 9 Calibration Accessories	
00	No hardware
01	Cal./ref. flowmeter and ref. pressure regulator
02	Autocalibration Systems – order by separate part number (for safe areas only)

Level 10 Electronics to Probe Cable	
00	No cable – integral electronics
10	20' (6m) cable – remote electronics
11	40' (12m) cable – remote electronics
12	60' (18m) cable – remote electronics
13	80' (24m) cable – remote electronics
14	100' (30m) cable – remote electronics
15	150' (45m) cable – remote electronics
16	200' (61m) cable – remote electronics

ORDERING INFORMATION – Direct Replacement Oxymitter Probe replaces all older Westinghouse and Rosemount probes, as well as most competitive probes.

Operates on most existing electronics, and also on the Xi enhanced interface electronics.

Model	Description
OXT4ADR	In Situ Oxygen Transmitter – for use with existing electronics or Xi electronics

Level 1 Sensing Probe Type	
1	Ceramic diffusion element probe (ANSI)
3	Snubber diffusion element (ANSI)
4	Ceramic diffusion element probe (DIN)
6	Snubber diffusion element (DIN)
7	Ceramic diffusion element probe (JIS)
9	Snubber diffusion element (JIS)

Level 2 Probe Assembly	
0	18" (457mm) Probe
1	18" (457mm) Probe with abrasive shield
2	3' (0.91m) Probe
3	3' (0.91m) Probe with abrasive shield ⁴
4	6' (1.83m) Probe
5	6' (1.83m) Probe with abrasive shield ⁴
6	9' (2.74m) Probe
7	9' (2.74m) Probe with abrasive shield ⁴
8	12' (3.66m) Probe ¹
9	12' (3.66m) Probe with abrasive shield ⁴
A	15' (4.57m) Probe with abrasive shield
B	18' (5.49m) Probe with abrasive shield

Level 3 Mounting Adapter – Stack Side ²	
0	No adapter plate
1	Mounting to stack (new installation)
2	Mounting to model 218/225/240 mounting plate (with probe support tube removed)
3	Mounting into existing model 218/225/240 probe support tube or bypass
4	Mounting into competitor's mounting ³
5	Model 132 / World Class 3000 adapter plate

Level 4 Mounting Adapter – Probe Side	
0	No mounting hardware
1	Mounting probe only (ANSI)
2	Mounting probe with abrasive shield (ANSI)
4	Mounting probe only (DIN)
5	Mounting probe with abrasive shield (DIN)
7	Mounting probe only (JIS)
8	Mounting probe with abrasive shield (JIS)

Level 5 Termination Unit	
11	Standard filtered termination
12	Transient protected filtered termination

Level 6 Arrangement-Existing Electronics	
03	No hardware. For use with 218 analog electronics, world-class IFT electronics or Oxymitter electronics, Xi electronics
04	Westinghouse/Rosemount digital (218A) or universal electronics
05	VeriTrim electronics
07	Model 132 digital electronics
08	For use with Yokogawa electronics (cold junction comp. in probe junction box)
09	For use with other competitive oxygen analyzer systems

Note:

Order manual calibration accessories separately

263C152G01 Reference air regulator set

771B635H01 (2 required) flowmeters for calibration and reference air

Option Notes for Oxt4A, Oxt5A and Oxt4ADR

Notes:	In-Situ Oxygen Transmitter – HART® Smart High Sulfur Service: High sulfur cell can be selected for any probe; add a line item note to your purchase order requesting the high sulfur ZrO ₂ cell in place of the standard ZrO ₂ cell. Add 4232 UOM to the system matrix UOM total. Example: Note: Delete – standard cell P/N 4847B63G01 Add – high sulfur cell P/N 4847B63G02 Cell replacement kits for high sulfur service are also available. Consult P/N 4849B94XX in the Combustion Solutions Center Spare Parts list.
Level 2:	Option: 0 25/55 kgs/lbs shipping weight
Level 2:	Option: 2 27/60 kgs/lbs shipping weight
Level 2:	Option: 4 30/66 kgs/lbs shipping weight
Level 2:	Option: 6 33/72 kgs/lbs shipping weight
Level 2:	Option: 8 35/78 kgs/lbs shipping weight
Level 2:	Option: 3 45/100 kgs/lbs shipping weight
Level 2:	Option: 5 50/110 kgs/lbs shipping weight
Level 2:	Option: 1, 7 54/120 kgs/lbs shipping weight
Level 2:	Option: 9 60/130 kgs/lbs shipping weight
Level 2:	Option: A 66/145 kgs/lbs shipping weight
Level 2:	Option: B 72/158 kgs/lbs shipping weight
Level 2:	Option: 1, 3, 5, 7, 9, A, B Recommended usages: high velocity particulates in flue stream, installation within 10' (3.5 m) of soot blowers or heavy salt cake build up. Applications: pulverized coal, recovery boilers, lime kiln. Regardless of application, abrasive shields with support brackets are recommended for 9' (2.74 m) and 12' (3.66 m) , 16' (4.57 m) and 18' (5.49 M) probe installations, particularly horizontal installations.
Level 3:	Option: 4 Where possible, specify SPS number, otherwise provide details of the existing mounting plate as follows: Plate with studs: Bolt circle diameter, number and arrangements of studs, stud thread, stud height above mounting plate. Plate without studs: Bolt circle diameter, number and arrangement of holes, thread, depth of stud mounting plate with accessories.
Level 6:	Option: 1 Startup, calibration and operation can be implemented using the standard membrane keypad. Remote access and additional functionality available via HART®/FOUNDATION Field Communications (Model 375 Hand-held Communicator or AMS) with Oxymitter device descriptor (DD) required.

ORDERING INFORMATION – AUTOCALIBRATION ACCESSORIES

Model	Description
XSO2CAL	O ₂ Autocalibration Accessories - apply to Oxymitter or Xi electronics. General purpose only.

Level 1	Single Probe Sequencers Autocalibration options	
	00	None
	01	SPS 4001 Single Probe Sequencer, general purpose NEMA 4X, includes check valve for probe

Level 2	Intelligent Multiprobe Sequencers (IMPS)	
	00	None
	01	IMPS Intelligent Probe Sequencer, single-probe, general purpose NEMX 4X, includes valve for probe
	02	IMPS Intelligent Probe Sequencer, two-probe, general purpose NEMX 4X, includes valve for probe
	03	IMPS Intelligent Probe Sequencer, three-probe, general purpose NEMX 4X, includes valve for probe
	04	IMPS Intelligent Probe Sequencer, four-probe, general purpose NEMX 4X, includes valve for probe
	05	IMPS Intelligent Probe Sequencer, single-probe, 115V heated general purpose NEMX 4X, includes valve for probe
	06	IMPS Intelligent Probe Sequencer, two-probe, 115V heated general purpose NEMX 4X, includes valve for probe
	07	IMPS Intelligent Probe Sequencer, three-probe, 115V heated general purpose NEMX 4X, includes valve for probe
	08	IMPS Intelligent Probe Sequencer, four-probe, 115V heated general purpose NEMX 4X, includes valve for probe
	09	IMPS Intelligent Probe Sequencer, single-probe, 220V heated general purpose NEMX 4X, includes valve for probe
	010	IMPS Intelligent Probe Sequencer, two-probe, 220V heated general purpose NEMX 4X, includes valve for probe
	011	IMPS Intelligent Probe Sequencer, three-probe, 220V heated general purpose NEMX 4X, includes valve for probe
	012	IMPS Intelligent Probe Sequencer, four-probe, 220V heated general purpose NEMX 4X, includes valve for probe

ORDERING INFORMATION – OPTIONAL Xi ADVANCED ELECTRONICS

Model	Description
Xi	O ₂ Advanced electronics

Level 1	Xi Type
01	Future
02	Future
03	Future
04	Traditional Architecture Xi - all signal conditioning and operator interface via the Xi. Cable required, single channel only.
05	Traditional Architecture Xi - all signal conditioning and operator interface via the Xi. Cable required, single channel only, set up to run 44V world class probe

Level 2	Mounting
00	None
01	Panel Mount Kit with Gasket
02	2" Pipe/Wall Mount Kit

Level 3	Cable (For Traditional Architecture Xi Only)
00	None
10	20' (6m) Cable
11	40' (12m) Cable
12	60' (18m) Cable
13	80' (24m) Cable
14	100' (30m) Cable
15	150' (45m) Cable
16	200' (60m) Cable

Level 4	Stoichiometer Function
00	No
01	Single Channel
02	Dual Channel, (second channel not available for traditional architecture Xi)

Level 5	Programmable Reference Function
00	No
01	Single Channel
02	Dual Channel, (second channel not available for traditional architecture Xi)

Level 6	825 Deg C Process Function
00	No
01	Single Channel
02	Dual Channel, (second channel not available for traditional architecture Xi)

NOTES: Order Direct Replacement Oxymitter probe separately - Oxt4ADR

Xi Enhanced Interface - Panel Mounting Details

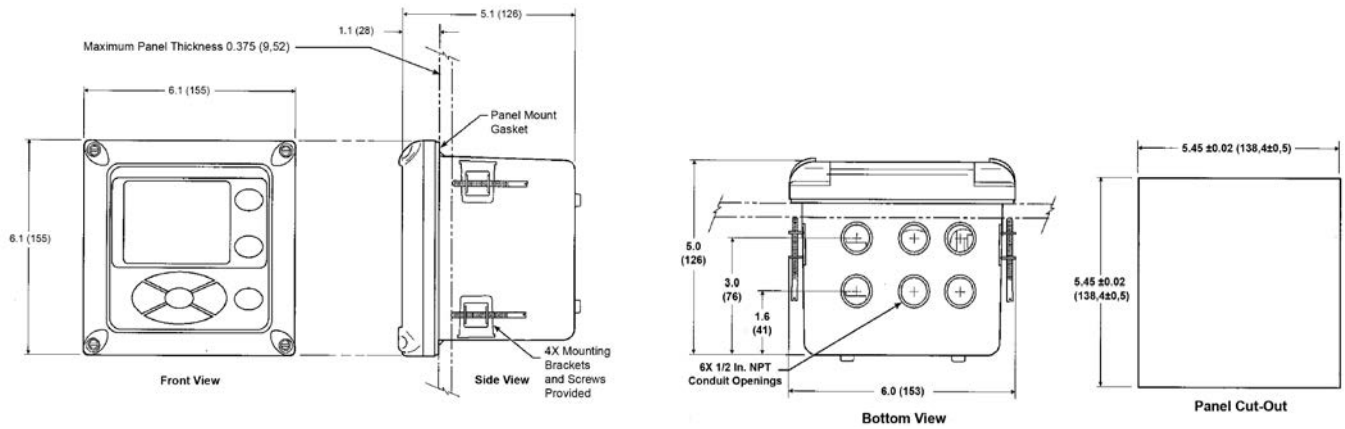

Xi Enhanced Interface - Wall/Surface and Pipe Mounting Details

WALL/SURFACE MOUNT

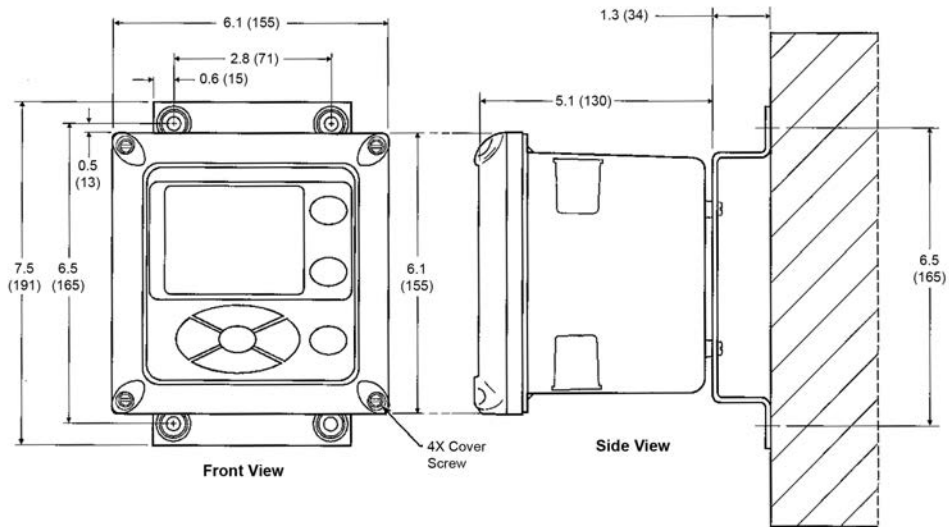

PIPE MOUNT

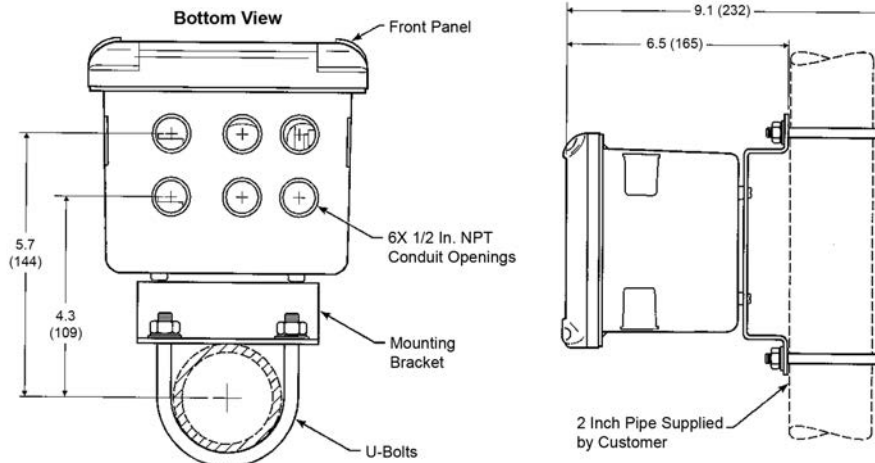

OXYMITTER ACCESSORIES

HART® Hand-held 475 Communicator

The FOUNDATION™ Fieldbus 475 Communicator is an interface device that provides a common communication link to HART®/FOUNDATION fieldbus compatible instruments, such as the Sulfur-Resistant Oxymitter. HART® Communications Protocol permits all the information available from the Sulfur-Resistant Oxymitter electronics to be transmitted over standard 4-20 mA signal wires or FOUNDATION fieldbus wires. By attaching the hand-held communicator at a termination point along the signal line, a technician can diagnose problems and configure and calibrate the Sulfur-Resistant Oxymitter as if he or she were standing in front of the instrument.



Bypass Packages

The specially designed Rosemount Bypass Package for oxygen analyzers has proven to withstand the high temperatures in process heaters while providing the same advantages offered by the in situ sensor. Inconel tubes provide effective resistance to corrosion, and the other components common to other sampling systems.

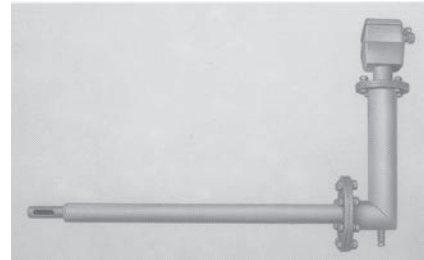

O₂ Calibration Gas Kits - pn. 6296A27G01

Rosemount's O₂ Calibration Gas and Service Kits have been carefully designed to provide a more convenient and fully portable means of testing, calibrating, and servicing Rosemount's oxygen analyzers. These lightweight, disposable gas cylinders eliminate the need to rent gas bottles.



Wireless THUM™ Adaptor

The Smart Wireless THUM Adaptor converts the standard 4-20mA signal from the Xi electronics to a wireless signal. All HART information is transmitted in addition to the process O₂ value.



SPECIAL ARRANGEMENTS

Special Cells for High Acid Service

Many combustion processes use fuels that contain sulfur or HCl. Special cells provide extended life in these difficult applications.



Catalyst Regeneration

Measure O₂ in regenerators at pressures up to 50 psi. In situ design resists plugging due to catalyst fines Class I, Div. I, Group B, C and D. Optional pressure balancing arrangement. Optional isolation valving system permits installation and withdrawal while the process is running. Specified by UOP. See Application Data Sheet ADS 106-300F.A01.

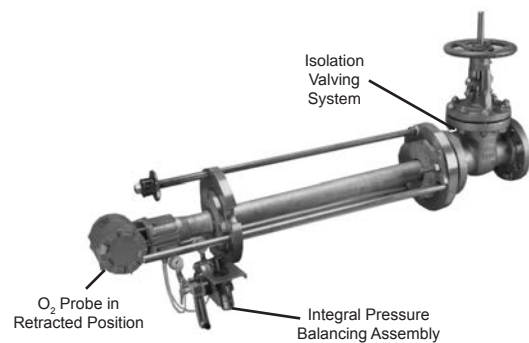

Pressure balanced in situ O₂ probe with optional isolation valving system (probe withdrawn)

Notes

Global Headquarters

Emerson Automation Solutions

6021 Innovation Blvd.
Shakopee, MN 55379, USA
+1 800 999 9307 or +1 952 906 8888
+1 952 949 7001
Gas.CSC@Emerson.com

North America Regional Office

Emerson Automation Solutions

8200 Market Blvd.
Chanhassen, MN 55317, USA
+1 800 999 9307 or +1 952 906 8888
+1 952 949 7001
RFQ-NA.RCCRFQ@Emerson.com

Latin America Regional Office

Emerson Automation Solutions

1300 Concord Terrace, Suite 400
Sunrise, FL 33323, USA
+1 954 846 5030
+1 952846 5121
RFQ.RMD-RCC@Emerson.com

Europe Regional Office

Emerson Automation Solutions Europe GmbH

Neuhofstrasse 19a P.O. Box 1046
CH 6340 Baar
Switzerland
+1 954 846 5030
+1 952846 5121
RFQ.RMD-RCC@Emerson.com

Asia Pacific Regional Office

Emerson Automation Solutions Asia Pacific Pte LTD

1 Pandan Crescent
Singapore 128461
+65 6777 8211
+65 6777 0947
Enquiries@AP.Emerson.com

Middle East and Africa Regional Office

Emerson Automation Solutions

Emerson FZE P.O. Box 17033
Jebel Ali Free Zone - South 2
+971 4 8118100
+971 4 88665465
RFQ.RMTMEA@Emerson.com



Analyticexpert.com



linkedin.com/company/Emerson-Automation-Solutions



Twitter.com/Rosemount_News



Facebook.com/Rosemount



Youtube.com/user/RosemountMeasurement



Google.com/+RosemountMeasurement

The Emerson logo is a trademark and service mark of Emerson Electric Co.
Rosemount and Rosemount logotype are trademarks of Emerson.
All other marks are the property of their respective owners.
© 2017 Emerson. All rights reserved.