

Rosemount™ 222

Toroidal Flow-Through Conductivity Sensor



SPECIFICATIONS

Wetted Materials: Teflon-lined carbon steel pipe, with carbon steel outer flanges. Option-21 has 316 SS outer flanges.

Temperature and Pressure:

Flange	Option	Temperature	Pressure
150 lb	-01 and -02	41°F(5°C) - 360°F (182°C)	125 psig (963 kPa abs)
300 lb	-05 and -06	41°F(5°C) - 360°F (182°C)	250 psig (1825 kPa abs)

Pressure (for CRN registration only):

Flange	Option	Pressure (max)
150 lb	-01 and -02, and -01-21	125 psig (963 kPa abs)
300 lb	-05 (1 inch)	200 psig (1480 kPa)
300 lb	-06 (2 inch)	250 psig (1825 kPa abs)

Outside flanges: ANSI B16.5 raised face, threaded.

INSTALLATION

First, decide whether the initial calibration will be done in the shop before installing the sensor or in the process piping after installing the sensor. Refer to the Calibration section for information about in-shop and in-process calibrations.

NOTE

Install the sensor in a location where it will be completely filled with process liquid.
A vertical pipe run with the flow from bottom to top is best.

1. Remove the grounding strap from the outer flanges. See Figure 1. **Save the strap and all the hardware for reassembly.**
2. Carefully remove the nuts, bolts, insulating bushings, and washers from the flanges. **Save the parts. They will be needed later and must be in good condition.** Separate the flange sets.
3. Remove **and save** the flange gaskets.
4. Install the outer flanges on the process piping, observing the dimensions noted in Figures 2 and 3. Use pipe joint compound or pipe tape to ensure the connections do not leak.
5. Install a ½ inch FNPT thermowell in the process piping within 6 ft. (1.8m) of the sensor. For best results place the thermowell as close as possible to the sensor.
6. Position the sensor between the process mating flanges with the flange gaskets inserted between each set of flanges. If the process piping is lined with a non-conductive material, a metal orifice plate (contact ring) must be installed between the flanges. Consult the factory for more information.
7. Align the bolt holes.
8. Insert an insulating sleeve in each bolt hole. See Figure 1.
9. Place a metal washer on each bolt, followed by an insulating washer. Insert the bolt through the insulating sleeve.
10. Place an insulating washer followed a metal washer on each bolt.

NOTE

Before tightening the bolts (step 11), be sure the flange gaskets are installed between the system piping and the sensor and that the insulating sleeves and washers are in place. For the sensor to operate properly there must no metal to metal contact between the sensor and the process piping.

11. Screw a nut onto each bolt and tighten according to the table. Follow the torquing sequence shown in Figure 1.

Flange	Torque
1 inch flange bolts	10 ft-lb (7.37 N-m)
2 inch flange bolts	25 ft-lb (18.43 N-m)

Do not over tighten the bolts.

12. Connect the grounding strap between the two outer flanges using the screws and washers removed in step 1. If an orifice plate contact ring is being used, connect the shorting strap to the two contact rings.
13. Install the temperature sensor in the thermowell. Use Teflon tape on the pipe threads. The insertion length is adjustable from 1.4 to 4.0 inches (36 to 102 mm). The temperature sensing zone, which extends 1.3 inches (33 mm) from tip of the sensor, must be inside the thermowell

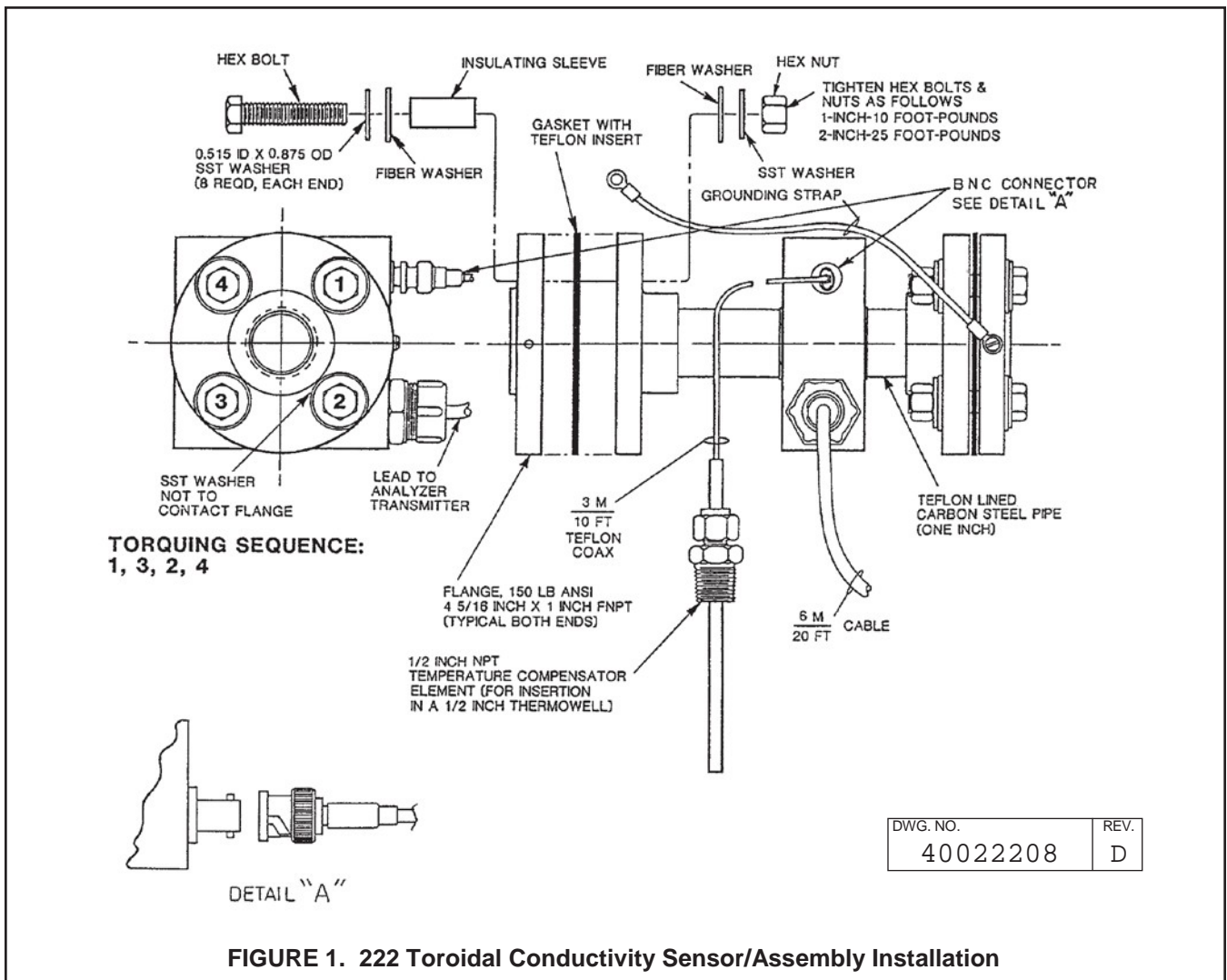

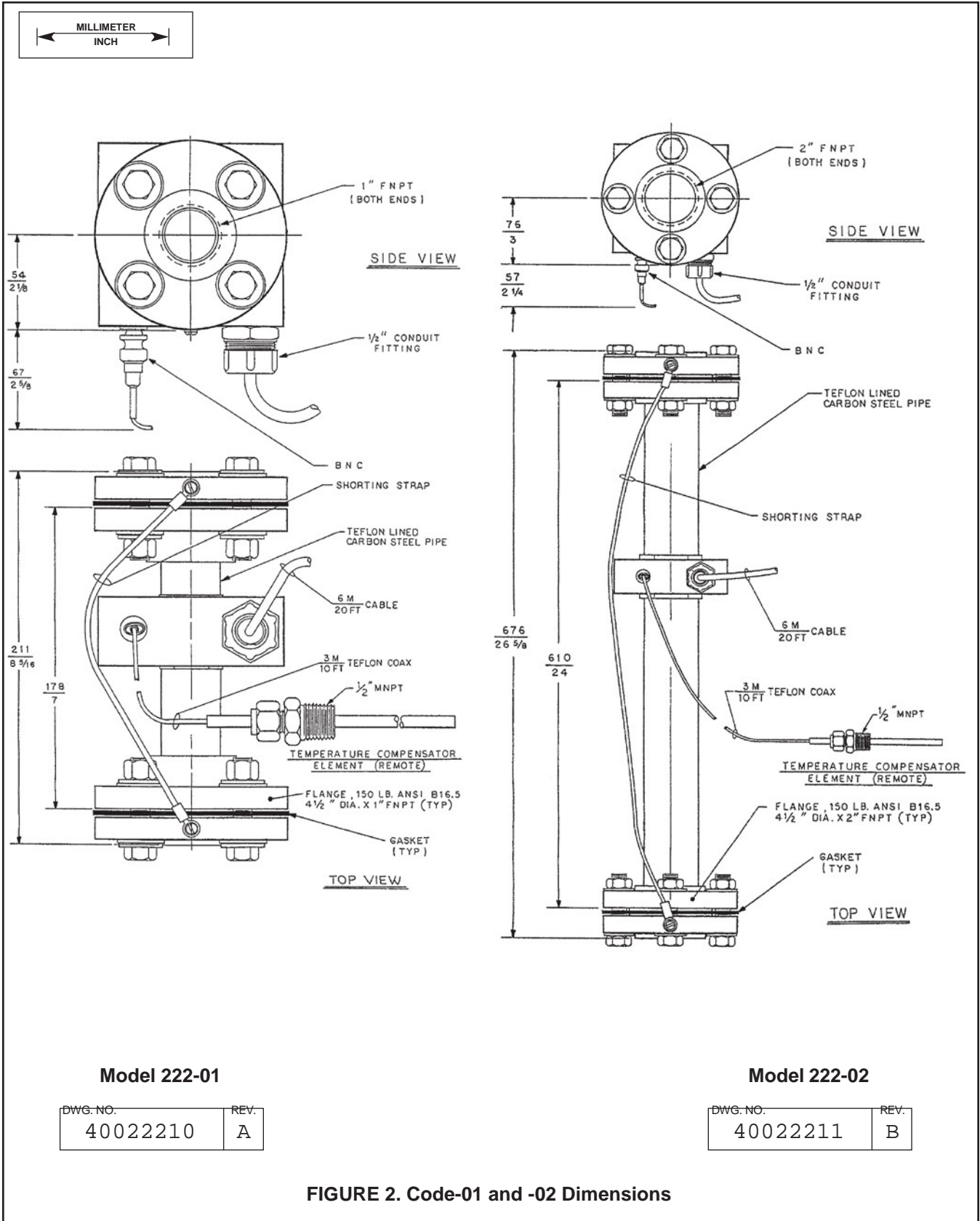

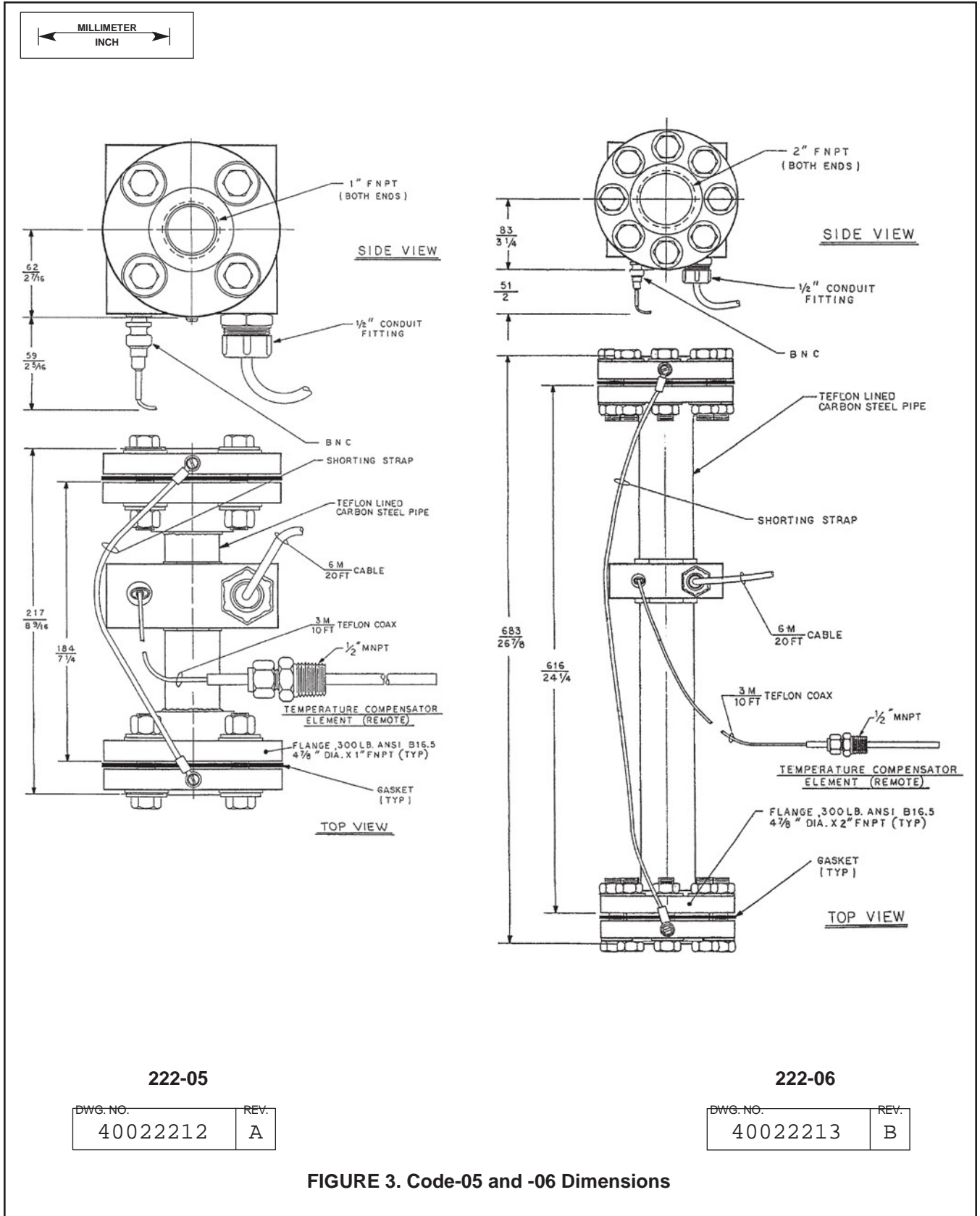

WIRING

Keep sensor wiring away from ac conductors and high current demanding equipment. **Do not cut cable.**
Cutting the cable may void the warranty.

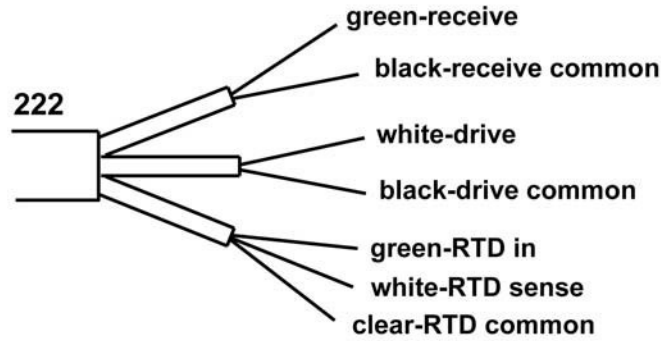

FIGURE 4. Wire Functions

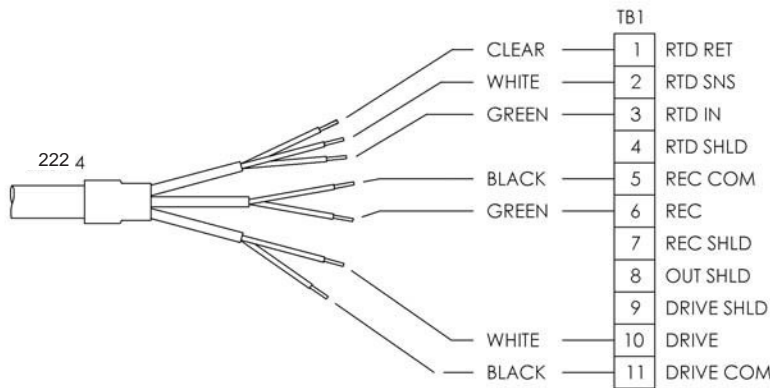

FIGURE 5. Wiring 222 sensor to 1056 and 56 analyzers

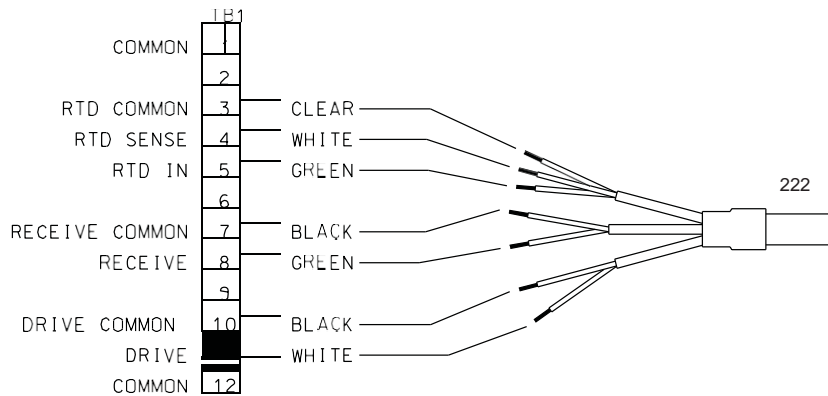

FIGURE 6. Wiring 222 sensor to 54eC analyzer

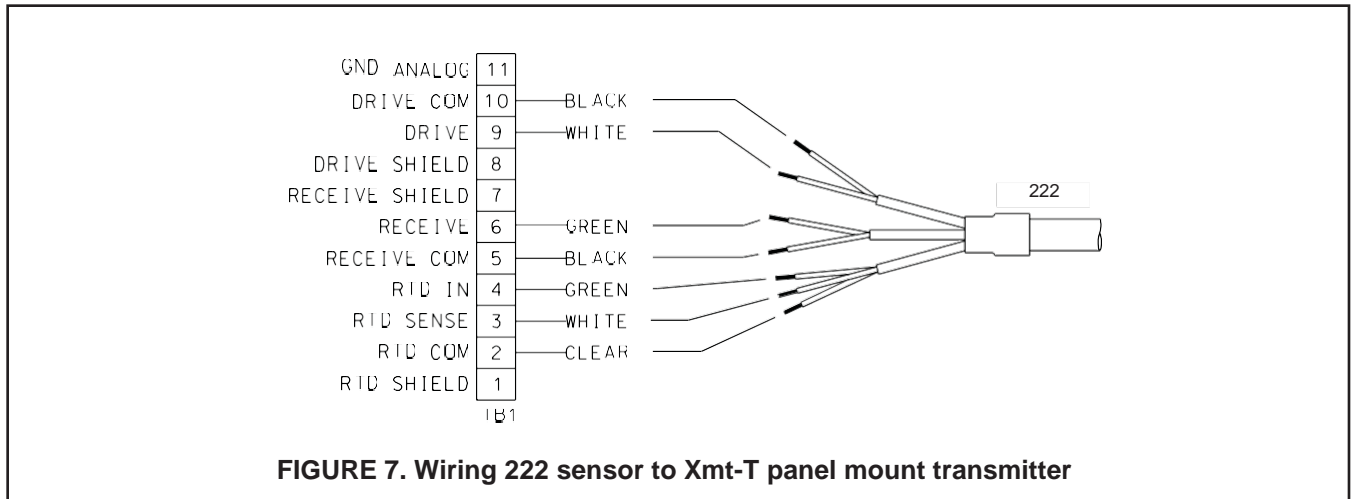

FIGURE 7. Wiring 222 sensor to Xmt-T panel mount transmitter

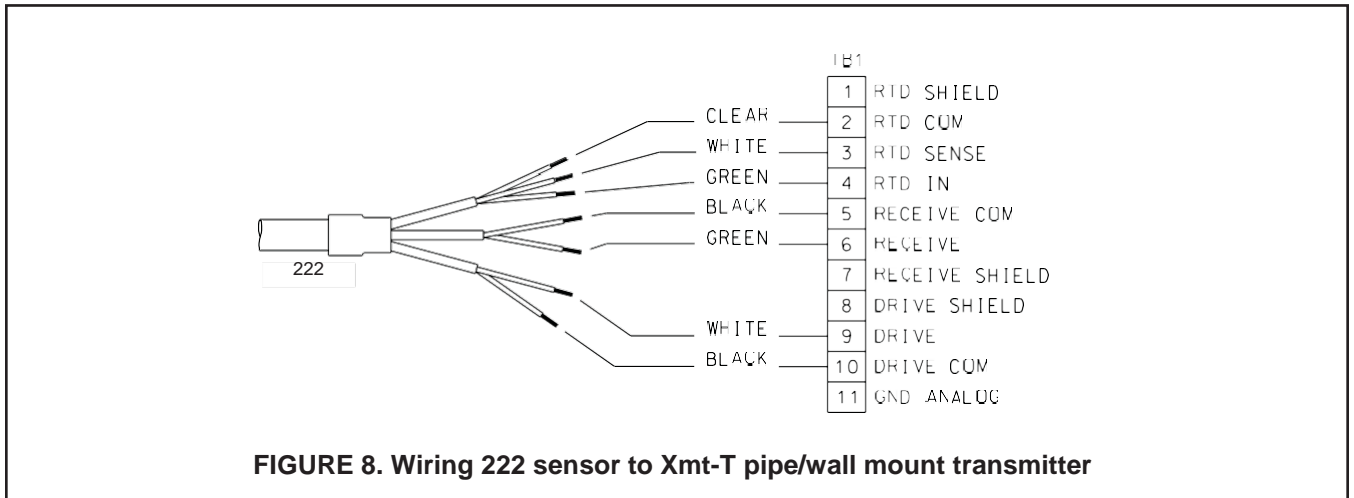

FIGURE 8. Wiring 222 sensor to Xmt-T pipe/wall mount transmitter

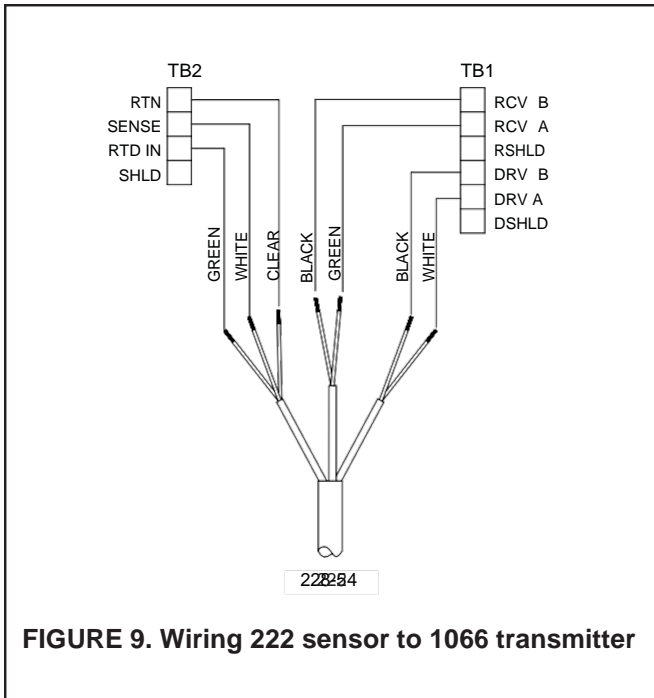

FIGURE 9. Wiring 222 sensor to 1066 transmitter

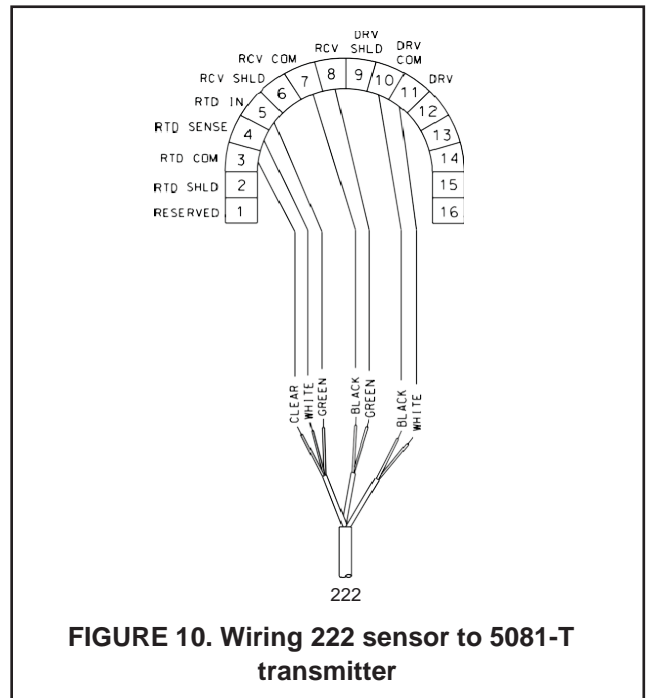

FIGURE 10. Wiring 222 sensor to 5081-T transmitter

WIRING THROUGH A REMOTE JUNCTION BOX

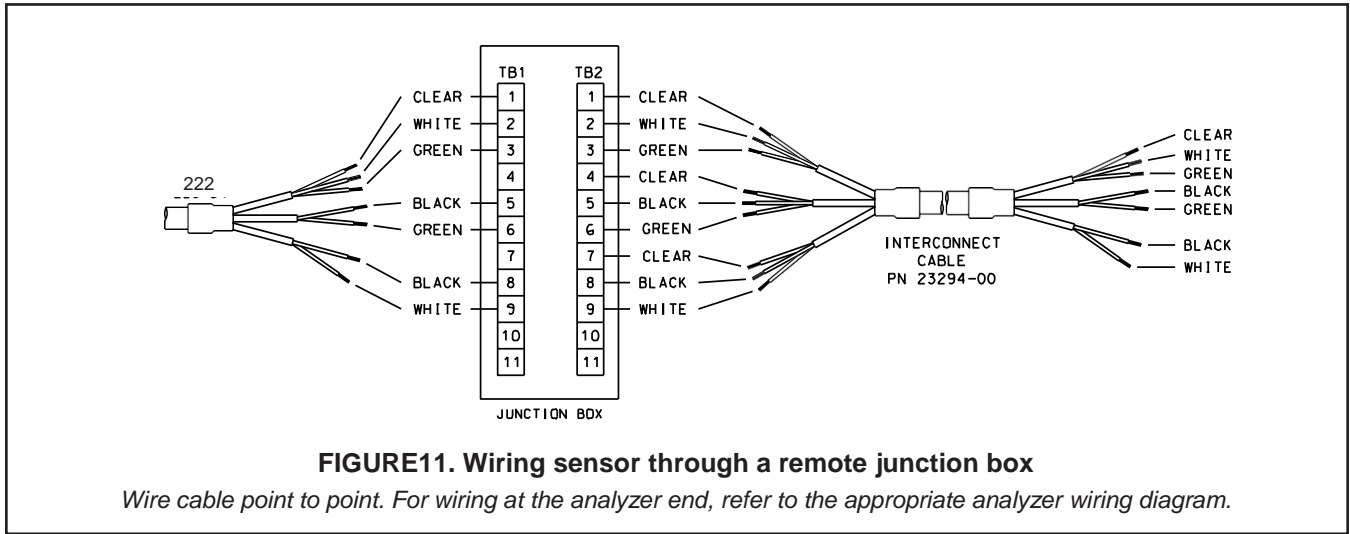

FIGURE 11. Wiring sensor through a remote junction box

Wire cable point to point. For wiring at the analyzer end, refer to the appropriate analyzer wiring diagram.

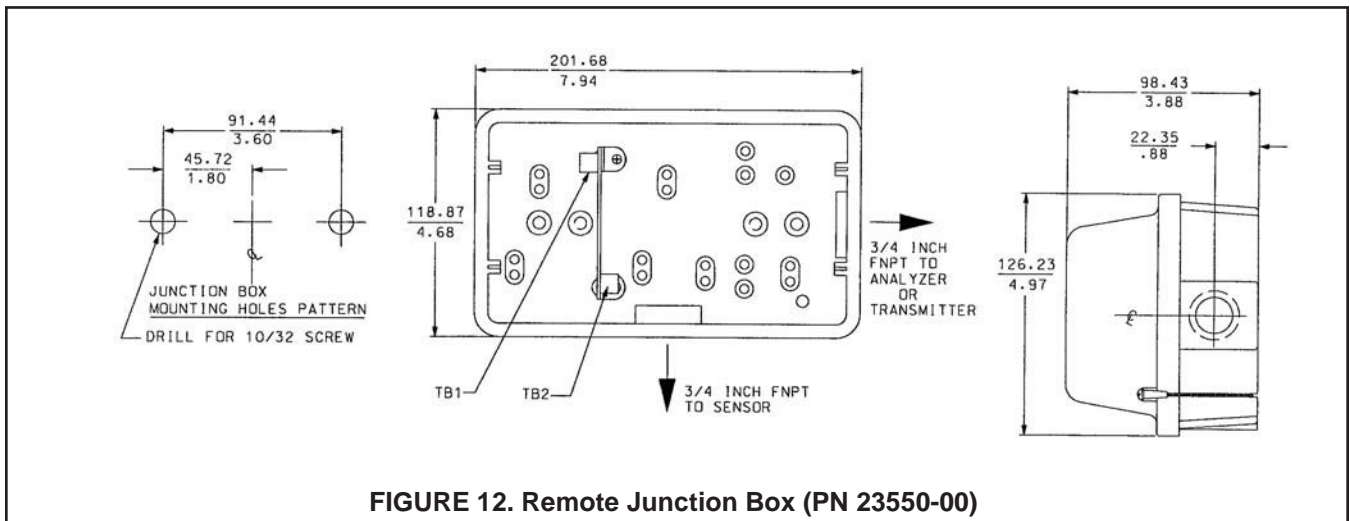

FIGURE 12. Remote Junction Box (PN 23550-00)

CALIBRATION

The nominal cell constant of the 1-inch diameter sensor is 6/cm and the nominal cell constant of the 2-inch diameter sensor is 4/cm. The error in the cell constant is about $\pm 10\%$, so conductivity readings made using the nominal cell constant will have an error of at least $\pm 10\%$. For higher accuracy the sensor must be calibrated.

The sensor can be calibrated using a standard solution or a previously calibrated sensor and analyzer. Calibration against a standard solution requires that the sensor and outer flanges be removed from the process piping. Generally it is a useful method only when the sensor is first installed. Otherwise, the sensor should be calibrated in place against a referee sensor and analyzer.

To calibrate against a standard solution, screw a short length of metal pipe into one of the outer flanges and cap the open end of the pipe. Stand the sensor on the capped end and fill it with standard to the level of the upper surface of the second outer flange. Be sure the shorting strap is connected to both flanges. Adjust the analyzer reading to match the known conductivity of the standard. Do not place a temperature sensor or any object inside the conductivity sensor during calibration. Doing so will alter the measured conductivity and introduce an error in the measurement.

Once the sensor has been installed in the process piping, removing it for calibration is impractical. In this case, calibrate the sensor against a referee sensor and analyzer, ideally while both sensors are simultaneously measuring the same process liquid. If this is not practical, calibrate the sensor against the results of a measurement made on a grab sample.

For more information about calibrating toroidal conductivity sensors, particularly precautions to take during in-process calibrations, refer to application sheet ADS 43-025, available on the Rosemount Analytical website.

TROUBLESHOOTING

PROBLEM	PROBABLE CAUSE	SOLUTION
Off-scale reading	Wiring is wrong.	Verify and correct wiring.
	RTD is open or shorted.	Check RTD for open or shorts. See Figure 13.
	Sensor is damaged.	Perform isolation checks. See Figure 13. Perform toroid check.
Noisy reading	Fluctuating process liquid level in the sensor.	Confirm that the sensor is installed in the process piping so that it is always filled with liquid. Installation in a vertical pipe run with flow from the bottom is best.
	Sensor cable is run near high voltage conductors.	Move the cable away from high voltage conductors.
	Sensor cable is moving.	Keep the sensor cable stationary.
Reading seems wrong (lower or higher than expected)	Bubbles are trapped in the sensor	Increase the flow if possible.
	Sensor is not filled with process liquid.	Confirm that the sensor is installed in the process piping so that it is always filled with liquid. Installation in a vertical pipe run with flow from the bottom is best.
	Cell constant is wrong.	Calibrate the sensor.
	Wrong temperature correction algorithm is being used.	Check that the temperature correction is appropriate for the sample. See analyzer manual for more information.
	Temperature reading is inaccurate.	Disconnect the RTD leads (Figure 13) and measure the resistance between the in and common leads. The resistance should be close to the value in Table 1.
	Measured temperature does not match temperature at the sensor.	Move the thermowell and RTD closer to the sensor.
	Toroids are damaged.	Perform toroid check.

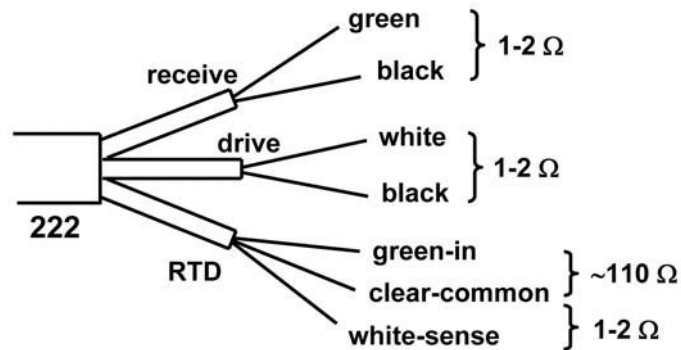

FIGURE 13. Disconnect wires from analyzer before measuring resistance.

TABLE 1.

Temperature	Resistance
10°C	103.9 Ω
20°C	107.8 Ω
25°C	109.7 Ω
30°C	111.7 Ω
40°C	115.5 Ω
50°C	119.4 Ω

Checking toroid operation

Use the following procedure to check the operation of the toroids.

1. Disconnect the shorting strap from one of the outer flanges. The conductivity reading will drop to zero.
2. Pass a short piece of heavy gauge wire through the space between the toroid assembly and the pipe.
3. Connect the ends of the wire to a resistance decade box.
4. Turn off temperature correction in the analyzer. If raw conductivity is available as a temperature compensation selection, choose raw. If raw is not available, choose manual temperature correction and set the temperature to 25°C (77°F).
5. Adjust the resistance to the values shown in the table below. The conductivity reading displayed by the analyzer should be **close** to the values shown.

Resistance	1-inch sensor K = 6/cm	2-inch sensor K = 4/cm
100 Ω	60 mS/cm	40 mS/cm
200 Ω	30 mS/cm	20 mS/cm

The toroids are working properly if increasing the resistance by a factor of two causes the displayed conductivity to decrease by a factor of two.

REPLACEMENT PARTS

PN	Description
2002557	Insulation kit, 1 inch, 150 lb flange, 2 sets (See Note)
2002558	Insulation kit, 1 inch, 300 lb flange, 2 sets (See Note)
2002559	Insulation kit, 2 inch, 150 lb flange, 2 sets (See Note)
2002560	Insulation kit, 2 inch, 300 lb flange, 2 sets (See Note)
8950101	Pt 100 RTD assembly
23294-00	Interconnecting cable, specify length (maximum 100 ft (30.5m))

Note: Each insulation kit contains two flange gaskets and sufficient insulating sleeves, insulating washers, and stainless steel washers to replace both flange seals of one sensor. The kit does not contain flange bolts or nuts.

www.Emerson.com/RosemountLiquidAnalysis



[Youtube.com/user/Rosemount](https://www.youtube.com/user/Rosemount)



Analyticexpert.com



[Twitter.com/Rosemount_News](https://twitter.com/Rosemount_News)



facebook.com/Rosemount

Emerson Automation Solutions

8200 Market Blvd.
Chanhassen, MN 55317,
USA
Tel +1 800 999 9307
Fax +1 952 949 7001

Liquid.CSC@Emerson.com

©2017 Emerson Automation Solutions. All rights reserved.

The Emerson logo is a trademark and service mark of Emerson Electric Co. Rosemount is a mark of one of the Emerson family of companies. All other marks are the property of their respective owners.

The contents of this publication are presented for information purposes only, and while effort has been made to ensure their accuracy, they are not to be construed as warranties or guarantees, express or implied, regarding the products or services described herein or their use or applicability. All sales are governed by our terms and conditions, which are available on request. We reserve the right to modify or improve the designs or specifications of our products at any time without notice.