

TUpH[™] pH/ORP Sensors

TUpH REFERENCE TECHNOLOGY ENSURES LONG LIFE in processes that coat, foul, and poison most other electrodes.

- Large Surface Area reference junction
- Helical Reference Pathway
- SILCORE^{™1} Contaminant Barrier

SUPERIOR CHEMICAL RESISTANCE to tackle the most aggressive applications, even CHLORINE DIOXIDE in pulp bleaching towers.

- TITANIUM and TEFZEL^{®2} sensor construction
- PEEK internal construction
- Choice of KALREZ^{®2} or VITON^{®2} seals

RESISTS ATTACK BY MOST ORGANIC SOLVENTS

FEATURES AND APPLICATIONS

The TUpH large area reference junction for minimal maintenance requirements: The reference junction provides an electrical connection between the reference electrode and the sample, and helps maintain a stable reference potential, regardless of the change in sample pH. The TUpH reference electrode junction, the entire plastic tip surrounding the glass pH electrode, maintains a steady reference signal even in the dirtiest of applications because it resists plugging (a common cause of pH signal drift). This large reference junction area is made of micron sized reference pathways used for ionic exchange so it resists plugging by large particles and will continue to send a steady pH signal, even in the dirtiest of applications. The TUpH reference junction technology has been field-proven for minimum maintenance requirements.

The TUpH helical reference pathway stops reference poisoning. Ions diffuse through the reference pathways and a charge is passed to the reference element. The reference element must be protected



MODEL 398R

RETRACTABLE DESIGN allows sensor to be removed for calibration and maintenance without process shutdown



MODEL 398

INSERTION/SUBMERSION DESIGN allows for variable insertion depths and simple sensor removal without cable twisting

from contamination by poisoning ions such as sulfide, mercury, cyanide, and ammonia or else the pH signal will drift. The TUpH sensor's long internal helical reference pathway hinders and slows down the rate of contaminants migrating to the reference element thereby providing a longer sensor life. This essential component is constructed of PEEK thermoplastic, one of the most durable materials available.

The entire line of TUpH model sensors now incorporate the new SILCORE technology contaminant barrier. This triple-seal barrier prevents moisture and material impurities from migrating to the reference electrode's lead wire. By preventing these contaminants from compromising the integrity of the pH measurement, sensor life is increased, especially at higher temperatures. In addition, the SILCORE technology provides added protection against sensor failure due to vibrations and shock by transferring damaging energy away from the glass-to-metal seal.

¹ TUpH, AccuGLASS, and SILCORE are trademarks of Rosemount Analytical.

² Tefzel, Kalrez, and Viton are registered trademarks of DuPont Performance Elastomers.

The AccuGLASS¹ pH bulb means the Models 398 and 398R resist cracking and have near theoretical response even at extreme pH values. A slotted tip surrounding the glass bulb provides additional protection against breakage. The sensor can be oriented with the bulb directly in the stream, or it can be turned ninety degrees, permitting the shroud to protect the glass bulb from particles.

The TUpHTM reference junction and helical pathway combined with the AccuGLASS pH glass performs exceptionally well in dirty, high solid applications and requires only minimum maintenance. This is the toughest pH sensor on the market and is still unmatched by all other pH sensors.

The chemical-resistant construction of Tefzel^{®2}, titanium, and the TUpH reference junction makes Models 398 and 398R the ideal sensors for measuring pH in harsh process liquids. Use Models 398 and 398R to measure pH in sour water strippers, in pulp bleaching towers that use chlorine dioxide, and in process streams containing a variety of organic solvents.

All TUpH sensor models have been specifically designed for improved life in harsh, dirty, and abrasive applications such as lime slurry, waste treatment, paper machine headbox, and pigment/dye applications, where large quantities of suspended solids are present. Various sensor materials, depending on the sensor model, is available for a variety of different application needs.

Models 398 and 398R are housed in a titanium tube. The molded Tefzel^{®2} TUpH construction is offered with a choice of seals (Viton^{®2} or Kalrez^{®2}). Combining high quality materials with the TUpH reference technology and AccuGLASS pH bulb allows for ultimate chemical resistance and makes Models 398 and 398R the perfect choice for measuring pH in harsh, demanding processes.

Models 398 and 398R are available with 15 ft. of cable for wiring directly to an analyzer/transmitter or a remote junction box. The Model 398R retractable sensor is also available with 9.5 in. of cable for use with a sensor head junction box which attaches to the sensor tube via a compression fitting.

A preamplifier converts the high impedance pH signal into a stable, noise-free signal and must be used with all pH sensors. The preamplifier can be in a remote junction box or integral to the analyzer/transmitter. All TUpH Sensors are compatible with all Rosemount Analytical and other manufacturers' instruments.

¹ TUpH, AccuGLASS, and SILCORE are trademarks of Rosemount Analytical.

² Tefzel, Kalrez, and Viton are registered trademarks of DuPont Performance Elastomers.

PERFORMANCE AND PHYSICAL SPECIFICATIONS FOR MODELS 398 AND 398R*

Measured Range:

ORP: -1500 to 1500mV
pH: GPHT hemi bulb or GPLR flat bulb -
AccuGLASS, 0 - 14 pH

Percent Linearity Over pH Ranges:

pH range	Hemi Bulb	Flat Bulb
0-2 pH	94%	93%
2-12 pH	99%	98%
12-13 pH	97%	95%
13-14 pH	92%	—

Reference: Permeable Tefzel with secondary helical pathway

Wetted Materials: Titanium, Tefzel, glass, platinum (ORP only), and choice of Viton or Kalrez

Process Connections: NONE

Must use 1 inch compression process connector (PN 23166-00 or 23166-01).

Also, Model 398R can be inserted through a ball valve

Cable: Standard integral 15 ft , optional 9.5 in. (for Model 398R only);
Recommended Interconnect: PN 9200273

Maximum Process Pressure and Temperature:
250 psig (1825 kPa [abs]) at 212°F (100°C)

Maximum Pressure at Retraction or Insertion (Model 398R only):

64 psig (524 kPa [abs]) Code 21
35 psig (343 kPa [abs]) Code 25

Minimum Conductivity: 75 µS/cm, nominal 100 µS/cm

Weight/Shipping Weight:

Model 398 sensor: 1.0 lb/2.0 lb (0.45 kg/0.9 kg)

Model 398R sensor:
Code 21; 2.0 lb/3.0 lb (0.9 kg/1.40kg)
Code 25; 3.0 lb/4.0 lb (1.40 kg/1.80kg)

**unless otherwise specified*

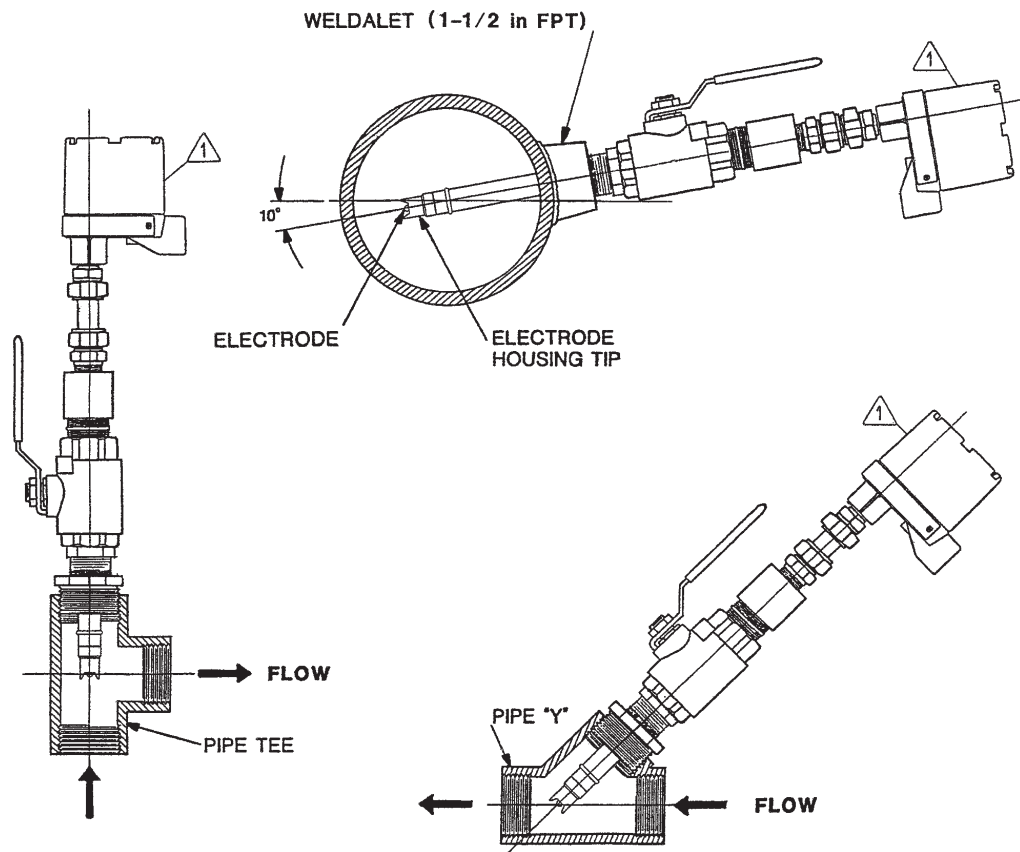

1 JUNCTION BOX IS OPTIONAL

Typical Mounting Details - Model 398R Retraction Version

*Note: Sensor must be mounted at an angle between 10° and 90° above the horizontal.
Pipe tees and weldalets provided by customer.*

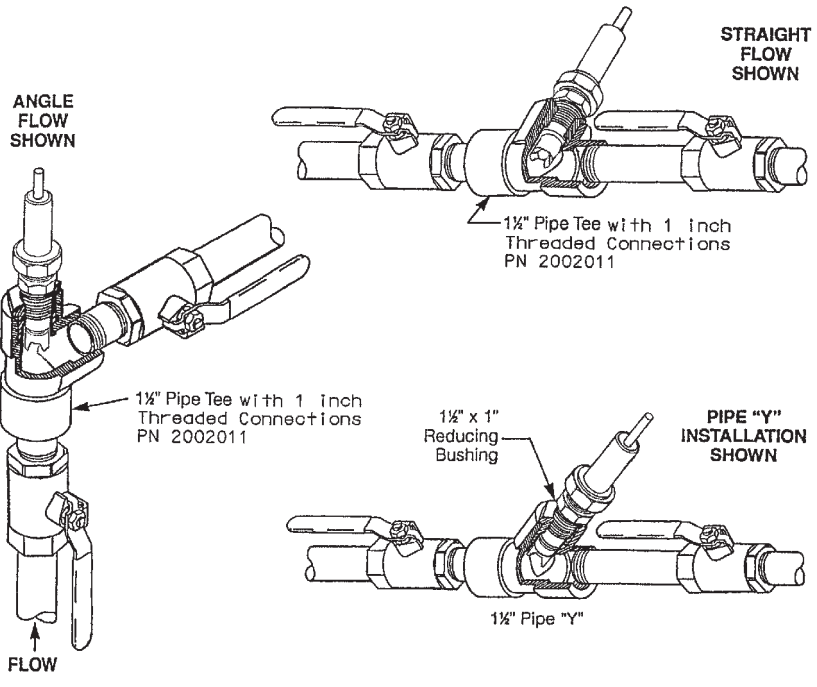

Recommended Flow-Through and Insertion Installation for Model 398
 1-1/2 inch Pipe Tee (PN 2002011) with 1 inch threaded connections

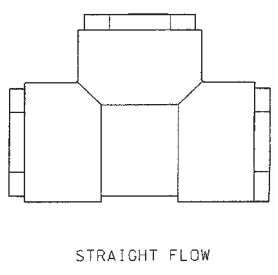
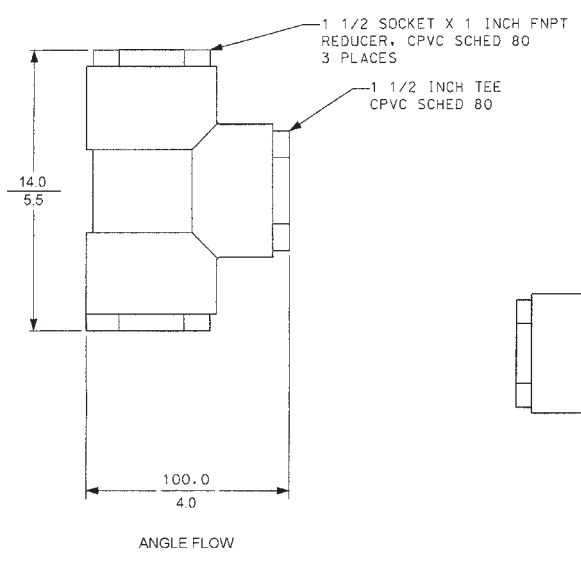

PN 2002011

Insertion Installations for Model 398

Model 398 can be inserted into a tee, such as the one shown here (PN 2002011, 1-1/2 in. tee with 1 in. threaded process connection), for angle or straight process flow. Other tees are available; see page 9 for part numbers.

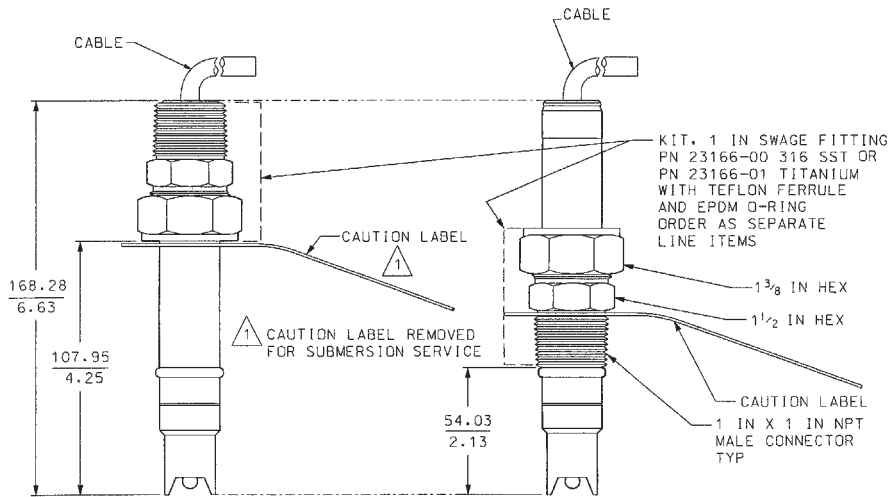

NOTE: FOR SUBMERSION APPLICATIONS
NOTE LIMITS AND REMOVE LABEL

NOTE: INSTALL CAUTION LABEL AS SHOWN
ON INSERTION FITTING FOR ALL
INSERTION APPLICATIONS
LABEL MUST BE VISIBLE AT ALL TIMES

Dimensional Drawing - Model 398 Insertion/Submersion Sensor

The process connector can be placed onto Model 398 with the threads facing down for insertion mounting into a tee or the threads facing up for a submersion pipe mount connection. See page 9 for photos of sensor with the process connector.

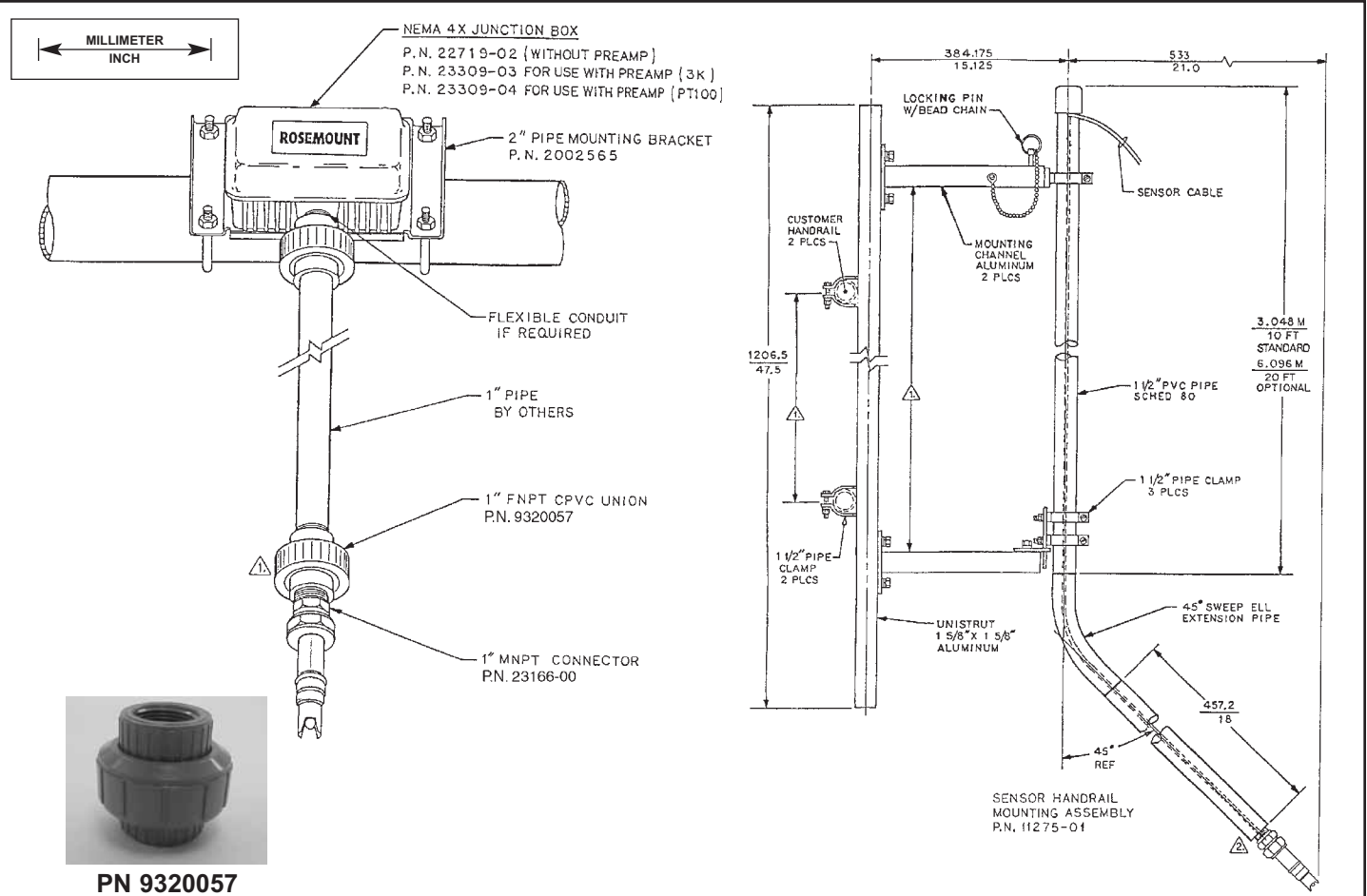

PN 9320057

Submersion Installations for Model 398

Model 398 can be submersed in ponds or tanks in various ways, including a customer-supplied pipe mount set-up using PN 9330022 pipe mount union. Also the Handrail Mounting Assembly PN 11275-01 can be used and includes all necessary parts to mount the sensor at the end of a pipe using a process connector (PN23166-00 or 23166-01).

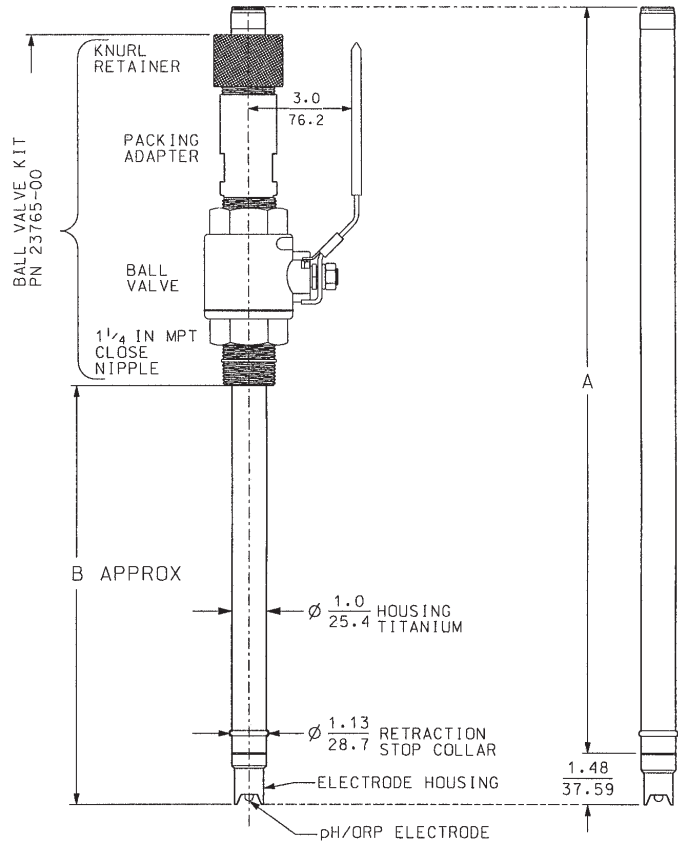

A		B		OPTION
IN	/ MM	IN	/ MM	
21.60	/ 548.64	12.12	/ 307.85	21
36.10	/ 916.94	26.62	/ 676.15	25



Dimensional Drawing — Model 398R with and without Optional Ball Valve PN 23765-00

Note: Add five (5) inches to dimension A if mounting a sensor head junction box onto the sensor.

MILLIMETER
INCH



Ball Valve Kit (PN 23240-00) used with Model 398R retractable sensor



A process connector (PN 23166-00 or -01) must be used to connect the sensor to Ball Valve Kit 23240-00. Process connector can be purchased separately.

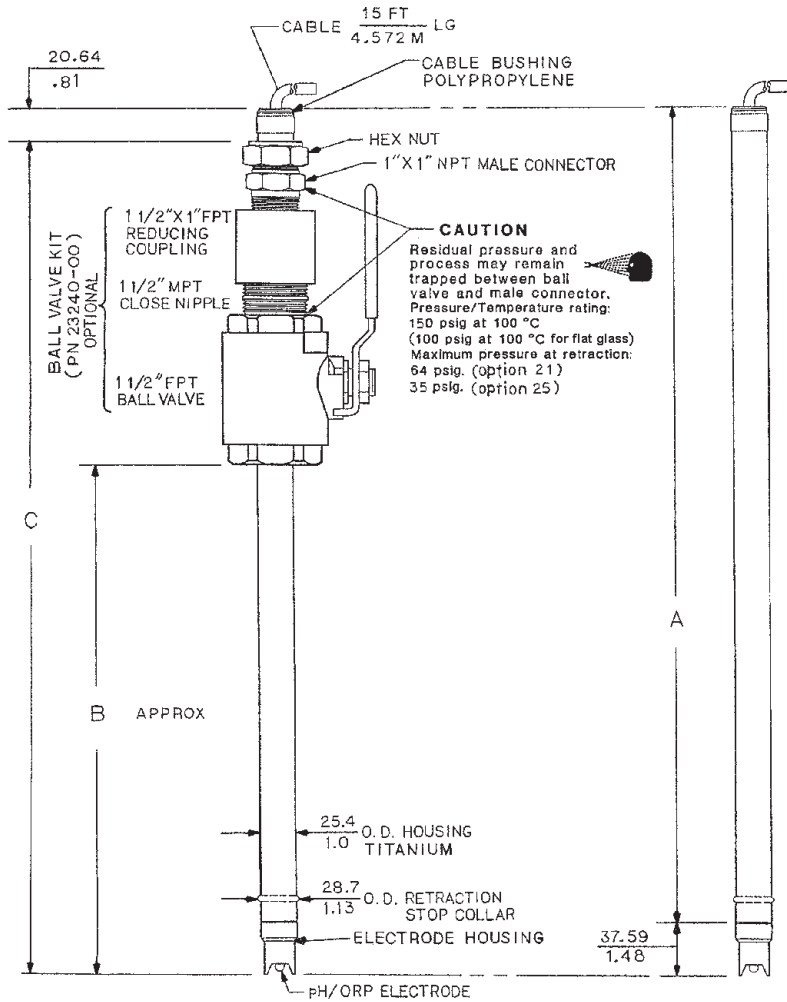

A	B	C	OPTION
MM / IN	MM / IN	MM / IN	
548.64 / 21.60	327.66 / 12.90	565.66 / 22.27	21
916.94 / 36.10	659.96 / 27.40	933.96 / 36.77	25

DWG. NO. 40396R05 REV. A

Dimensional Drawings of Model 398R shown with and without 1-1/2 in. Ball Valve PN 23240-00

For the ball valve installation shown, the ball valve kit (PN 23240-00) and 1 in. x 1 in. process connector (PN 23166-00 or 23166-01) must be purchased separately.

Note: Add five (5) inches to dimension A if mounting a sensor-head junction box onto the sensor.

The **Model 398 Sensor**, housed in a titanium tube and made with a patented Tefzel reference junction, can be used with a 1 inch MNPT process connector (purchased separately). The sensor is available with a hemi bulb glass pH electrode or a platinum and glass ORP electrode and with Pt100 or 3K temperature compensation. The 398 is provided with a standard 15 ft cable. A preamplifier must be used if the sensor is more than 15 ft from the analyzer/transmitter. Junction box kits with preamplifiers must be ordered separately. Process connector must also be ordered separately.



MODEL 398 TU _p H INSERTION/SUBMERSION TITANIUM pH SENSOR	
CODE	MEASURING ELECTRODE TYPE (Required Selection)
10	GPHT hemi glass, General Purpose High Temperature (0-14 pH)
12	ORP
CODE	O-RING MATERIAL (Required Selection)
30	EPDM
31	Viton
32	Kalrez (recommended for applications with Chlorine Dioxide)
CODE	ANALYZER/TC COMPATIBILITY (Required Selection)
50	For Models 1181 (3K TC)
54	For Models 1054A/B, 1055, 2081,54/54e, 81, 3081, 4081, 5081, Xmt, SCL-(P/Q) (PT 100 RTD)
CODE	OPTIONAL SELECTIONS (see drawings below)
62	15 ft Cable, no BNC (Not valid w/Option 50) for wiring directly to 1055, 54/54e, 81, 3081, 4081, 5081, Xmt Transmitter/Analyzers
398 - 10 - 32 - 54 EXAMPLE	

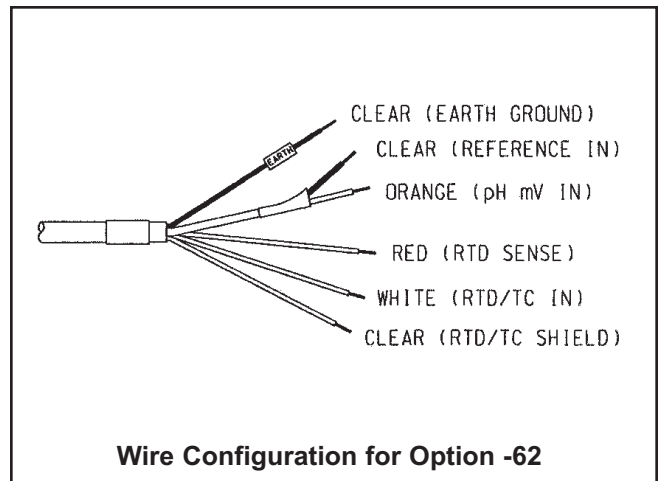
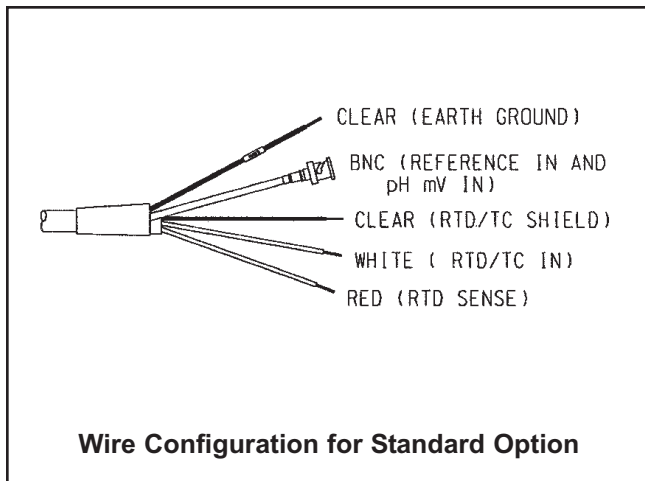

FOR FIRST TIME MODEL 398 INSERTION OR SUBMERSION INSTALLATIONS, ROSEMOUNT ANALYTICAL RECOMMENDS USING THE FOLLOWING GUIDE:

1. Process Connector Accessories (required for all first time installations with 1-inch process connection threads)	Weight/Shipping Weight
Choose one: PN 23166-00, 316 SST, 1 in. x 1 in. NPT process connector, with EPDM o-ring	0.5 lb (0.3 kg)/1.0 lb (0.5 kg)
PN 23166-01, Titanium, 1 in. x 1 in. NPT process connector, with EPDM o-ring	0.5 lb (0.3 kg)/1.0 lb (0.5 kg)
PN 9510066, Nylon, 1 in. x 1 in. NPT process connector (submersion only)	0.5 lb (0.3 kg)/1.0 lb (0.5 kg)
Choose one (optional process connector o-rings)	
PN 9550220, Kalrez o-ring, 2-214	0.1 lb (0.05 kg)/1.0 lb (0.5 kg)
PN 9550099, Viton o-ring, 2-214	0.1 lb (0.05 kg)/1.0 lb (0.5 kg)
2. Mounting Accessories (optional)	
Choose one: PN 915240-03 PVC flow through tee, 3/4 in. NPT process connection	1.0 lb (0.5 kg)/1.5 lb (0.7 kg)
PN 915240-04 PVC flow through tee, 1 in. NPT process connection	1.0 lb (0.5 kg)/1.5 lb (0.7 kg)
PN 915240-05 PVC flow through tee, 1 1/2 in. NPT process connection	1.0 lb (0.5 kg)/1.5 lb (0.7 kg)
PN 11275-01 Sensor handrail mounting assembly	15 lb (6.8 kg)/17 lb (7.7 kg)
PN 2002011 1-1/2 in. CPVC Tee with 1 in. FNPT connection	1.0 lb (0.5 kg)/1.5 lb (0.7 kg)
PN 23728-00 Low Flow Cell, acrylic	1.0 lb (0.5 kg)/1.5 lb (0.7 kg)
3. Remote Junction Boxes (optional, recommended for sensor to analyzer distances of more than 15 ft)	
Choose one: PN 23555-00 includes preamplifier for Models 54, 81, 3081, 4081	1.3 lb (0.6 kg)/2.0 lb (1.0 kg)
PN 23309-03, uses PN 22698-02 plug-in preamplifier (purchased separately) for Model 1181 Analyzer	1.3 lb (0.6 kg)/2.0 lb (1.0 kg)
PN 23309-04, uses PN 22698-03 plug-in preamplifier (purchased separately) for Models 1054 series, 2054, 2081 Analyzers	1.3 lb (0.6 kg)/2.0 lb (1.0 kg)
PN 23054-03 includes preamplifier for Solu Cube Model 2700	3.1 lb (1.4 kg)/4.0 lb (2.0 kg)
4. Extension cables (used with remote junction boxes)	
Choose one: PN 23646-01, 11 conductor, shielded, prepped	0.5 lb/ft (0.3 kg/ft)/ 1.0 lb/ft (0.5 kg/ft)
PN 9200273, 11 conductor, shielded, unprepped	0.5 lb/ft (0.3 kg/ft)/ 1.0 lb/ft (0.5 kg/ft)
5. Wiring Aids	
Choose one: PN 9120531 BNC splitter, used in place of option -62 or BNC coax prepping for connections to junction box (PN 23555-00); Models 1181, 1054, 2081, 54, 81, 3081, 4081; SoluComp (SCL-P-014); and Model 2700 Preamplifier (PN 23054-03) NONE: No wiring aids required for connections to preamplifier PN 22698-02, preamplifier PN 22698-03, or Models 1054A, 1054B, and 2054	



Metal Process Connector PN 23166-xx (xx = 00 for 316 SST and xx = 01 for titanium) can be used for insertion or submersion Model 398 sensor connection to 1-inch tee fittings. It also must be used to connect Model 398R to ball valve PN 23240-00 or directly to the process.



The metal process connector gives the sensor various insertion depths, depending on where the user locates the compression fitting. Also the threads can be switched to face the cable end of the sensor for connection to submersion pipes.

ORDERING INFORMATION

The **Model 398R Sensor**, housed in a titanium tube and made with a patented Tefzel reference junction, can be used with a ball valve (order separately) for hot tap applications. The sensor is available with a hemi bulb glass pH electrode or a platinum and glass ORP electrode and with Pt100 or 3K temperature compensation. The 398R is provided with a standard 15 ft cable and is offered with an optional 9.5 in. cable for easy wiring to sensor head junction boxes. A preamplifier must be used if the sensor is more than 15 ft from the analyzer/transmitter. Junction box kits with preamplifiers must be ordered separately. Process connector and ball valve assemblies must also be ordered separately.

MODEL 398R TUpH RETRACTABLE pH SENSOR	
CODE	MEASURING ELECTRODE TYPE (Required Selection)
10	GPHT hemi glass, General Purpose High Temperature (0-14 pH)
12	ORP
CODE	SENSOR LENGTH (Required Selection)
21	21 in. Titanium Tube
25	36 in. Titanium Tube
CODE	O-RING MATERIAL (Required Selection)
30	EPDM
31	Viton
32	Kalrez (recommended for applications with Chlorine Dioxide)
CODE	ANALYZER/TC COMPATIBILITY (Required Selection)
50	For Models 1181 (3K TC)
54	For Models 1054A/B, 1055, 2081,54/54e, 81, 3081, 4081, 5081, Xmt, SCL-(P/Q) (PT 100 RTD)
CODE	OPTIONAL SELECTIONS (see drawings below)
60	9.5 in. Cable with BNC (for use with Model 1181, 1054 series, 2054, 2081 Sensor head junction boxes)
61	9.5 in. Cable no BNC (Not valid w/option -50) (for use with Model 54, 81, 3081 Sensor head junction boxes)
62	15 ft Cable, no BNC (Not valid w/Option 50) for wiring directly to 1055, 54/54e, 81, 3081, 4081, 5081, Xmt Transmitter/Analyzers
398R - 10 - 21 - 32 - 54 EXAMPLE	

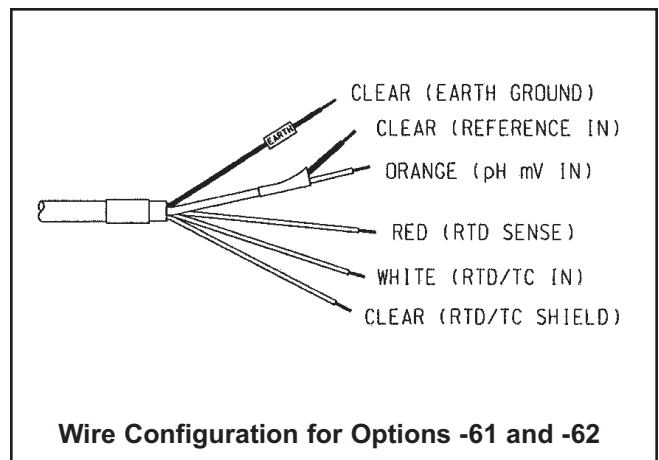
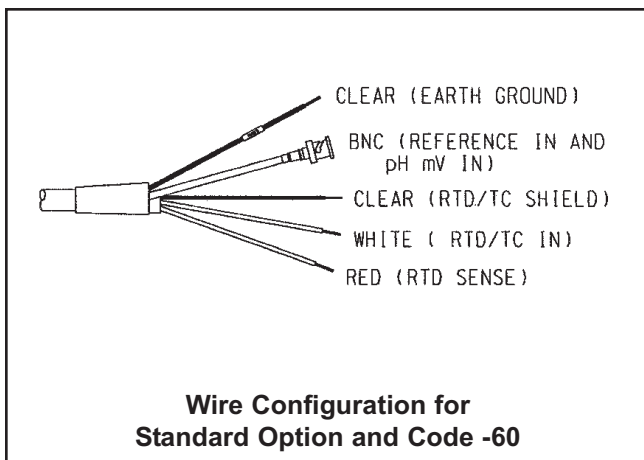

FOR FIRST TIME INSTALLATIONS OF MODEL 398R RETRACTABLE SENSOR, ROSEMOUNT ANALYTICAL RECOMMENDS USING THE FOLLOWING GUIDE

ACCESSORIES	WEIGHT/SHIPPING WEIGHT
1. Retractable Mounting	
<p>A. Choose one (required for all first time installations without ball valves or with 1-1/2 in. ball valve):</p> <p>PN 23166-00, 1 in. MNPT process connector, Stainless Steel with EPDM O-ring</p> <p>PN 23166-01, 1 in. NPT process connector, Titanium with EPDM O-ring</p> <p>B. Choose one (Optional; Process Connector O-rings):</p> <p>PN 9550220, O-ring, Kalrez, 2-214</p> <p>PN 9550099, O-ring, Viton, 2-214</p> <p>C. Choose one:</p> <p>PN 23240-00, 1-1/2 in. ball valve assembly, 316 SST (process connector required)</p> <p>PN 23765-00, 1-1/4 in. ball valve assembly, 316 SST</p>	<p>0.5 lb (0.3 kg)/1.0 lb (0.5 kg)</p> <p>0.5 lb (0.3 kg)/1.0 lb (0.5 kg)</p> <p>0.1 lb (0.05 kg)/1.0 lb (0.5 kg)</p> <p>0.1 lb (0.05 kg)/1.0 lb (0.5 kg)</p> <p>6.0 lb (3.0 kg)/7.0 lb (3.5 kg)</p> <p>6.0 lb (3.0 kg)/7.0 lb (3.5 kg)</p>
2. Junction Boxes (Optional; Choose either Sensor Head or Remote)	
<p>A. Sensor Head Junction Boxes (used with 9.5 in. cable length sensor) Choose one:</p> <p>PN 23709-00; includes preamplifier for Models 54, 81, 3081</p> <p>PN 23708-01; includes preamplifier for Models 1054 series, 2054, 2081</p> <p>PN 23707-00; includes preamplifier for Model 1181</p> <p>B. Remote Junction Boxes (used with 15 ft cable length sensor) Choose one:</p> <p>PN 23555-00; includes preamplifier for Models 54, 81, 3081</p> <p>PN 23309-03; uses preamplifier for Model 1181</p> <p>PN 23309-04; uses preamplifier for Models 1054 series, 2054, 2081</p> <p>PN 23054-03; includes preamplifier for SoluCube Model 2700</p>	<p>3.3 lb (1.5 kg)/4.0 lb (2.0 kg)</p> <p>3.3 lb (1.5 kg)/4.0 lb (2.0 kg)</p> <p>3.3 lb (1.5 kg)/4.0 lb (2.0 kg)</p> <p>1.3 lb (0.6 kg)/2.0 lb (1.0 kg)</p> <p>1.3 lb (0.6 kg)/2.0 lb (1.0 kg)</p> <p>1.3 lb (0.6 kg)/2.0 lb (1.0 kg)</p> <p>3.1 lb (1.4 kg)/4.0 lb (2.0 kg)</p>
3. Wiring Configuration (no option needed with remote junction boxes - PN 23309-03, 23309-04, and 23555-00):	
<p>Choose one:</p> <p>Order option -60 (standard with BNC connector) for PN 23707-00 or 23708-01 sensor head junction boxes (see diagram on page 6)</p> <p>Order option -61 (no BNC) for PN 23709-00 sensor head junction box (see diagram on page 6)</p> <p>Order option -62 (no BNC) for PN 23550-00 and 23054-03 remote junction boxes (see diagram on page 6)</p>	
4. Extension Cables - Choose one:	
<p>PN 23646-01, 11 conductor, shielded, prepped</p> <p>PN 9200273, 11 conductor, shielded, unprepped</p>	<p>0.1 lb/ft (0.05 kg/ft)/1.0 lb/ft (0.5 kg/ft)</p> <p>0.1 lb/ft (0.05 kg/ft)/1.0 lb/ft (0.5 kg/ft)</p>

OTHER ACCESSORIES

PART	DESCRIPTION	WEIGHT/SHIPPING WEIGHT
22698-00	Preamplifier plug-in for remote junction box (PN 23309-03), for Model 1003	0.1 lb (0.05 kg)/1.0 lb (0.5 kg)
22698-02	Preamplifier plug-in for remote junction box (PN 23309-03), for Models 1181/1050	0.1 lb (0.05 kg)/1.0 lb (0.5 kg)
22698-03	Preamplifier plug-in for remote junction box (PN 23309-04), for Models 1054A/B, 2054, 2081	0.1 lb (0.05 kg)/1.0 lb (0.5 kg)
22743-01	Pt100 Preamplifier for Model 1181	0.1 lb (0.05 kg)/1.0 lb (0.5 kg)
22744-01	3K Preamplifier for Model 1181	0.1 lb (0.05 kg)/1.0 lb (0.5 kg)
23557-00	Preamplifier for remote junction box (PN 23555-00), for Models 54/3081/81	0.2 lb (0.1 kg)/1.0 lb (0.5 kg)
23550-00	Remote Junction box with extension board	3.3 lb (1.5 kg)/4.0 lb (2.0 kg)
9550167	O-ring, 2-214, EPDM for process connector	0.1 lb (0.05 kg)/1.0 lb (0.5 kg)
9550099	O-ring, Viton, for process connector	0.1 lb (0.05 kg)/1.0 lb (0.5 kg)
9550220	O-ring, Kalrez, for process connector	0.1 lb (0.05 kg)/1.0 lb (0.5 kg)
9210012	Buffer solution, 4.01 pH, 16 oz	1.2 lb (0.5 kg)/2.0 lb (1.0 kg)
9210013	Buffer solution, 6.86 pH, 16 oz	1.2 lb (0.5 kg)/2.0 lb (1.0 kg)
9210014	Buffer solution, 9.18 pH, 16 oz	1.2 lb (0.5 kg)/2.0 lb (1.0 kg)
2001492	Stainless Steel Tag, specify marking	0.1 lb (0.05 kg)/1.0 lb (0.5 kg)



*The right people,
the right answers,
right now.*

**ROSEMOUNT ANALYTICAL
CUSTOMER SUPPORT CENTER
1-800-854-8257**



ON-LINE ORDERING NOW AVAILABLE ON OUR WEB SITE
<http://www.raihome.com>

Specifications subject to change without notice.



Credit Cards for U.S. Purchases Only.



Emerson Process Management

2400 Barranca Parkway
Irvine, CA 92606 USA
Tel: (949) 757-8500
Fax: (949) 474-7250

<http://www.raihome.com>

© Rosemount Analytical Inc. 2010

