

**Instruction Manual**

PN 51-381+/rev.G

March 2012

Model 381+

# pH/ORP Sensor



## ESSENTIAL INSTRUCTIONS

### READ THIS PAGE BEFORE PROCEEDING!

Rosemount Analytical designs, manufactures, and tests its products to meet many national and international standards. Because these instruments are sophisticated technical products, you must properly install, use, and maintain them to ensure they continue to operate within their normal specifications. The following instructions must be adhered to and integrated into your safety program when installing, using, and maintaining Rosemount Analytical products. Failure to follow the proper instructions may cause any one of the following situations to occur: Loss of life; personal injury; property damage; damage to this instrument; and warranty invalidation.

- Read all instructions prior to installing, operating, and servicing the product. If this Instruction Manual is not the correct manual, telephone 1-800-654-7768 and the requested manual will be provided. Save this Instruction Manual for future reference.
- If you do not understand any of the instructions, contact your Rosemount representative for clarification.
- Follow all warnings, cautions, and instructions marked on and supplied with the product.
- Inform and educate your personnel in the proper installation, operation, and maintenance of the product.
- Install your equipment as specified in the Installation Instructions of the appropriate Instruction Manual and per applicable local and national codes. Connect all products to the proper electrical and pressure sources.
- To ensure proper performance, use qualified personnel to install, operate, update, program, and maintain the product.
- When replacement parts are required, ensure that qualified people use replacement parts specified by Rosemount. Unauthorized parts and procedures can affect the product's performance and place the safe operation of your process at risk. Look alike substitutions may result in fire, electrical hazards, or improper operation.
- Ensure that all equipment doors are closed and protective covers are in place, except when maintenance is being performed by qualified persons, to prevent electrical shock and personal injury.

## DANGER

### HAZARDOUS AREA INSTALLATION

Installations near flammable liquids or in hazardous area locations must be carefully evaluated by qualified on site safety personnel. This sensor is not Intrinsically Safe or Explosion Proof.

To secure and maintain an intrinsically safe installation, the certified safety barrier, transmitter, and sensor combination must be used. The installation system must comply with the governing approval agency (FM, CSA or BASEEFA/CENELEC) hazardous area classification requirements. Consult your analyzer/transmitter instruction manual for details.

Proper installation, operation and servicing of this sensor in a Hazardous Area Installation is entirely the responsibility of the user.

## CAUTION

### SENSOR/PROCESS APPLICATION COMPATIBILITY

**The wetted sensor materials may not be compatible with process composition and operating conditions. Application compatibility is entirely the responsibility of the user.**

## About This Document

This manual contains instructions for installation and operation of the Model 381+ High pH/ORP Sensor. The following list provides notes concerning all revisions of this document.

<u>Rev. Level</u>	<u>Date</u>	<u>Notes</u>
0	5/01	This is the initial release of the product manual. The manual has been reformatted to reflect the Emerson documentation style and updated to reflect any changes in the product offering.
A	6/02	Updated multiple drawings throughout.
B	7/02	Added 1055 wiring drawing and updated kPa references.
C	9/02	Revised drawing captions on page 9.
D	9/04	Add Xmt wiring drawings and delete Ultrasonic cleaner.
E	11/07	Added M certs on back page.
G	3/12	Update addresses - mail and web

### Emerson Process Management

2400 Barranca Parkway  
Irvine, CA 92606 USA  
Tel: (949) 757-8500  
Fax: (949) 474-7250

<http://www.rosemountanalytical.com>

© Rosemount Analytical Inc. 2012



**EMERSON**<sup>™</sup>  
Process Management

# MODEL 381+ pH/ORP SENSOR

## TABLE OF CONTENTS

<b>Section</b>	<b>Title</b>	<b>Page</b>
1.0	DESCRIPTION AND SPECIFICATIONS.....	1
1.1	Features and Applications.....	1
1.2	Specifications .....	2
1.3	Ordering Information .....	3
2.0	INSTALLATION .....	4
2.1	Installation .....	4
2.2	Submersion Installation .....	4
2.3	Insertion Installation .....	4
2.4	Flow Through Installation .....	7
2.5	Flow Powered Cleaner Installation .....	7
2.6	Wiring .....	7
3.0	START-UP .....	14
3.1	Start-Up .....	14
3.2	pH Calibration .....	14
3.3	ORP Standardization.....	14
4.0	MAINTENANCE .....	16
4.1	General .....	16
4.2	Sensor Removal.....	16
4.3	Monthly Maintenance .....	16
4.4	Annual Maintenance .....	16
4.5	Electrode Checking and Standardization .....	17
5.0	TROUBLESHOOTING .....	18
5.1	Sensor Troubleshooting .....	18
5.2	T.C. Element Evaluation.....	19
5.3	Ultrasonic Cleaner/Generator Troubleshooting.....	19
6.0	RETURN OF MATERIAL.....	20

# MODEL 381+ pH/ORP SENSOR

## LIST OF FIGURES

Figure No.	Title	Page
2-1	Sensor Component Locator Diagram.....	5
2-2	Submersion Installation Diagram .....	6
2-3	Insertion Installation Diagram.....	6
2-4	Flow Through Installation Diagram.....	7
2-5	Installation Details Low Flow Conditions (Code -03 and -04).....	8
2-6	Flow Powered Cleaner Component Locator (Code -04).....	8
2-7	Wiring Model 381+ to Models 54, 3081, and 81.....	9
2-8	Wiring through J-Box with Extension Board to Models 54, 3081, and 81 .....	9
2-9	Wiring Model 381+-52 through J-Box with Preamp to Models 54, 3081, & 81 .	10
2-10	Wiring to Solu Cube Junction Box (PN 23054-03).....	11
2-11	Wiring Model 381+-31-41/43-55 to Model 1055-10-22-32 .....	11
2-12	Wiring Model 381+-31-42-55 to Model 1055-22-32 .....	12
2-13	Wiring Model 381+-52-62 to Model 1055-22-32 through Remote J-Box .....	12
2-14	Wiring Model 381+-41-52 to Model Xmt-P .....	13
2-15	Wiring Model 381+-55 to Model Xmt-P .....	13

## LIST OF TABLES

Table No.	Title	Page
1-1	Recommended Accessories and Spare Parts.....	2
3-1	ORP of Saturated Quinhydrone Solutions .....	14
5-1	Troubleshooting.....	18
5-2	T.C. Element Resistance .....	19

## SECTION 1.0 DESCRIPTION AND SPECIFICATIONS

- **ADVANCED ON-LINE SENSOR DIAGNOSTICS\*** of the Model 381+ when used with the Models 54e pH/ORP and 1055 Analyzers, or 81, 3081, 4081, 5081-P, and Xmt-P pH/ORP Transmitters.
- **MOLDED POLYETHERSULFONE (PES) BODY** provides compatibility with a variety of processes.
- **MODULAR DESIGN** facilitates maintenance by eliminating mounting brackets and extraneous hardware.
- **INTEGRAL PREAMPLIFIER** provides reliable signal transmission.
- **DOUBLE JUNCTION, GEL-FILLED, REFERENCE CELL** provides high temperature performance, extended service life, and resists the effects of pumping, dilution and contamination.

### 1.1 FEATURES AND APPLICATIONS

The Rosemount Analytical Model 381+ Sensor measures the pH or the Oxidation Reduction Potential (ORP) of aqueous solutions in pipelines, open tanks or ponds. The sensor is used in most industrial applications including water and waste treatment plants.

The Model 381+pH Sensor features continuous on-line advanced diagnostics that allow the user to identify sensor failures such as coated reference junction or broken glass. Sensor diagnostics result in time and money savings by reducing the guesswork in sensor maintenance and replacement requirements. On-line sensor diagnostics are made possible by calculation of the temperature corrected glass electrode impedance and by characterizing failure modes.

The sensor is housed in a molded PES body and has two O-ring seals with breach lock threads which secure the PES cover. This provides a waterproof union for long operating life and easy removal for routine maintenance.

The modular body design eliminates the need for internal mounting brackets, terminal brackets and screws. All components are screw-type or plug-in-place, allowing for fast simple service.

The integral preamplifier conditions the high impedance glass electrode signal at the sensor, providing a transmission capability of up to 1000 feet (304.8 meters). The Rosemount Analytical method of preamplification has become the industry standard for reliable pH measurement. In submersion applications

at temperatures greater than 80°C, the preamplifier must be located in a remote junction box or in the instrument.

A double junction, gel-filled reference cell, a standard feature of the Model 381+, improves sensor life when unknown reference cell contaminants, such as sulfides, may exist. The gel solution maintains its viscosity at high temperatures, and resists the effect of pumping and dilution, resulting in an extended service life. A choice of wood or ceramic liquid junction allows the user to optimize performance by emphasizing reference lifetime (wood) or chemical resistance (ceramic).

In flow applications where crystalline or viscous coatings, such as calcium carbonate or petroleum oils, may coat the electrode surfaces and impede the sensor's performance, the flow-powered cleaning option may be used. A specially designed flow chamber directs the process fluid in a circular path carrying four Teflon<sup>1</sup> balls which clean the electrode surface, physically preventing accumulation of coating materials. Flow-powered cleaning is suitable for all hazardous area applications.

The Model 381+ comes with Pt100 temperature compensation and is compatible with the Models 54e pH/ORP and 1055 Analyzers, and 81, 3081, 4081, 5081-P, and Xmt-P pH/ORP Transmitters.

\* Patent pending

<sup>1</sup> Teflon is a registered trademark of E.I. du Pont de Nemours & Co.

**1.2 SPECIFICATIONS****Materials of Construction:**

Body, Cover and Flow Cell: Polyethersulfone (PES)  
 O-Rings: Viton<sup>1</sup>.  
 Measuring Electrode: Glass (platinum for ORP)  
 Liquid Junction: PVDF/wood (Code 20) or  
 PVDF/ceramic (Code 21)  
 Solution Ground/Temperature Compensator: 316  
 Stainless steel/EPDM

**Process Connections:** Submersion: 3/4-inch MNPT  
 Insertion: 2 " MNPT, Flow Through: 3/4 " MNPT

**Measuring Range:** pH: 0-14

ORP: -1400 to +1400 mV

**Temperature Compensation:** Automatic, 0 to 100°C  
 (32 to 212°F)

**Maximum Pressure/Temperature Rating:**  
 790 kPa abs at 100°C (100 psig at 212°F)

**Cable:** Prepped (P/N 23646-01)/unprepped  
 (P/N 9200273)

**Weight/Shipping Weight:** 1.0 kg/1.7 kg (2.2 lbs/3.7lbs)

<sup>1</sup>Viton is a registered trademark of E.I. duPont de Nemours & Co.

**TABLE 1-1 Recommended Accessories and Spare Parts**

P/N	DESCRIPTION	QUANTITY
2000734	Liquid Junction, Kynar/Wood	2
2000735	Liquid Junction, Kynar/Ceramic	2
22694-00	Electrode, pH, GP	2
22694-01	Electrode, High pH	2
22694-02	Electrode, pH, Ruggedized	2
22694-03	Electrode, pH, HF Resistant	4
22697-00	Electrode, pH Combination	
22697-01	Electrode, High pH, Combination	4
22723-00	Flow Powered Cleaner Balls (Qty 9)	1
22731-00	ORP Electrode, Platinum	2
22751-00	O-Ring Kit (Qty 5), Upper Body	1
22751-01	O-Ring Kit (Qty 5), Lower Body	1
22811-01	Flow Powered Cleaner Retrofit Kit for Code -00,-02	
22892-00	Flow Powered Cleaner Retrofit Kit for Code -03	
23018-00	Reference Electrode, Microjunction	2
23561-00	Preamplifier, Integral to 381+	1
23550-00	Junction Box, remote, with Extension Board, 54, 54e, 1055, 81, 3081, 4081, 5081, Xmt Compatible	
23551-00	Sensor Body complete, Pt 100 TC,	1
23552-00	Sensor Cover with 15 ft. Cable	1
23552-01	Sensor Cover with 15 ft. Coax Cable, without BNC	1
23552-02	Sensor Cover with 50 ft. Cable	1
23646-01	Cable extension, 11 conductor, Shielded, Prepped,	Price/Foot
23555-00	Junction Box, with Models 54, 54e, 1055, 81, 3081, 4081, 5081, Xmt Preamplifier	
23557-00	Preamplifier for Remote Junction Box, 54, 54e, 1055, 81, 3081, 4081, 5081, Xmt Compatible	1
32602-00	Flow Cell, PES	1
32605-00	Electrode Shroud, PES	
32606-00	Flow Cell Coupling Nut, PES	
32793-00	Flow Powered Cleaner, Ring	
32794-00	Flow Powered Cleaner Chamber	
9200273	Cable extension, 11 conductor, Shielded, Unprepped	Price/Foot
9210012	Buffer Solution, 4.01pH, 16 oz	4
9210013	Buffer Solution, 6.86pH, 16 oz	4
9210014	Buffer Solution, 9.18pH, 16 oz	4
R508-160Z	ORP Standard 500ml (460 mV± 10 at 20°C)	2
9210342	Reference Cell Recharge, KCl Gel, 250 ml	2
9550146	O-Ring, 2-229, Viton, Shroud	2
9550147	O-ring, 2-232, Viton, Flow Cell	2
11275-00	Handrail Mounting Bracket for Submersion Service	
1000857	Handrail Mounting Bracket for Submersion Service, for use with Remote Junction Box	

**1.3 ORDERING INFORMATION**

**Model 381+ pH/ORP Sensor** is housed in a PES body suitable for insertion, submersion or flow through installation. The sensor includes an integral preamplifier, measuring electrode, double junction gel filled reference cell, automatic temperature compensation, and a choice of two cable lengths, 15 ft. or 50 ft. (4.5 or 15.2 m). The Model 381+ sensor provides on line advanced diagnostic capabilities and is compatible with the Modeld 54e pH/ORP and 1055 Analyzers and Models 81, 3081, 4081, 5081, and Xmt pH/ORP Two-Wire Transmitters.

<b>MODEL 381+ INSERTION, SUBMERSION, FLOW THROUGH SENSOR</b>	
<b>CODE</b>	<b>INSTALLATION</b>
00	Insertion
02	Submersion
03	Flow Through
04	Flow Through with Flow Powered Cleaner (not available with ORP).
<b>CODE</b>	<b>MEASURING ELECTRODE</b>
10	General purpose pH
11	High pH Electrode, requires Code 21. For sodium concentrations greater than 1% or continuous measurement above 11 pH.
12	Ruggedized pH Electrode. For abrasive solutions.
13	Platinum ORP Electrode
14	Gold ORP Electrode
15	HF pH Electrode. For HF concentrations less than 100 ppm.
<b>CODE</b>	<b>LIQUID JUNCTION</b>
20	Wood/PVDF Liquid Junction
21	Ceramic/PVDF Liquid Junction
<b>CODE</b>	<b>TEMPERATURE COMPENSATION</b>
31	Automatic T.C., 100 ohm RTD.
<b>CODE</b>	<b>CABLE</b>
40	15 ft. (4.5 m) cable for integral sensor preamp
41	15 ft. (4.5 m) coax cable for remote preamp (requires Code 52)
43	50 ft. (15.2 m) cable for integral sensor preamp
<b>CODE</b>	<b>INTEGRAL PREAMPLIFIER</b>
52	Preamp NOT REQUIRED
55	Preamp for Model 54, 54e, 1055, 81, 3081, 4081, 5081-P, and Xmt-P
<b>381+</b>	<b>- 00 - 10 - 20 - 31 - 40 - 55</b>
	<b>EXAMPLE</b>

## SECTION 2.0 INSTALLATION

**2.1 INSTALLATION.** Prepare the sensor for installation as follows (see Figure 2-1):

1. Remove the cover from the body by grasping the body and rotating the cover 1/4-turn counter clockwise.
2. When the cover breaks loose from the body, pull the cover straight out.
3. Lubricate the seals of the glass electrode with O-ring lubricant, Rosemount Analytical P/N 2001928, and install the glass electrode in the body. Tighten the electrode nut by hand. DO NOT use tools.

### CAUTION

Do not get lubricant on tip of glass or metal electrode. It will disrupt the electrical circuit path.

4. Make sure the double junction electrode is threaded tightly.
5. Plug the preamplifier (or remote connector) onto the T.C. solution ground and microjunction reference electrode pins.
6. Connect the BNC connector from the glass electrode to the preamplifier (or remote connector).
7. Install the body O-rings. Make sure they are clean, and not twisted. Make sure the covers mating surfaces are clean.
8. Lubricate the body O-rings with O-ring lubricant, P/N 2001928.
9. Plug the cable connector to the preamplifier, making sure the cable is toward the center of the body.
10. Install the cover on the body so that the threads will engage.
11. Rotate the cover until the triangle on the body aligns with (or falls within) the adjacent mark on the cover.
12. While holding the sensor in an upright position (see Figure 2-1), remove the 1/4-inch shipping plug from the electrode tip end of the sensor.
13. Install the liquid junction in place of the 1/4-inch plug, using TEFLON tape on the liquid junction threads.

### CAUTION

DO NOT use pipe joint compound or pipe dope on the threads of the liquid junction. The electrical circuit will be disrupted if the liquid junction is contaminated.

**2.2 SUBMERSION INSTALLATION (Code 02).** To install the sensor in process proceed as follows (see Figure 2-2):

1. Wrap TEFLON tape on 3/4-inch MNPT threads of cover and on standpipe threads.

### CAUTION

Do not use a pipe wrench on the plastic parts. Severe damage could result.

2. Attach a 3/4-inch coupling to the sensor.
3. Attach electrode shroud to 2 inch MNPT.
4. Feed cable through the rigid standpipe.
5. Attach the rigid standpipe to the coupling.

### CAUTION

Rigid standpipe should be water-tight.

6. Tighten all fittings and secure the standpipe to minimize sensor movement. Use flexible conduit at the top of the rigid standpipe to permit removal of the sensor for periodic maintenance.
7. Refer to Section 2.6 and wire the sensor to the transmitter as described.

**2.3 INSERTION INSTALLATION (Code 00).** To install the sensor in the side of a tank, in a pipeline, or in a pipe "tee", proceed as follows (see Figure 2-3):

### CAUTION

Sensor must be installed within 80° of the vertical plane.

1. Use TEFLON tape on pipe joint, and install sensor as shown in Figure 2-3.

### CAUTION

Do not use a pipe wrench on the plastic sensor parts. Severe damage could result.

2. Tighten all fittings and sensor.
3. Refer to Section 2.6 for wiring instructions.
4. If desired, the cable may be installed in a conduit. Flexible conduit MUST be used at the sensor for a short distance to permit removal for periodic maintenance. Use the 3/4-inch MNPT threads on the cover to attach the conduit to the sensor.



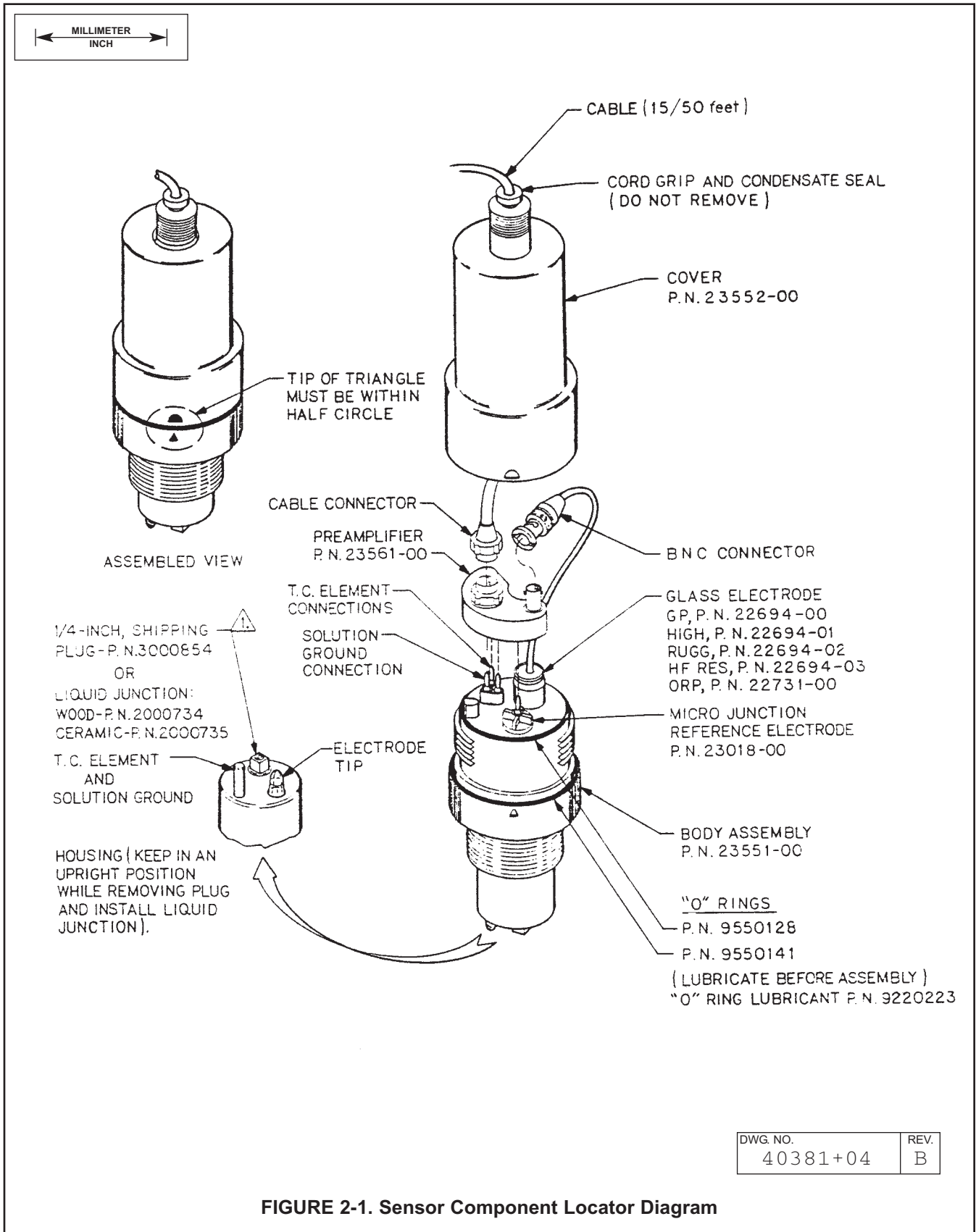

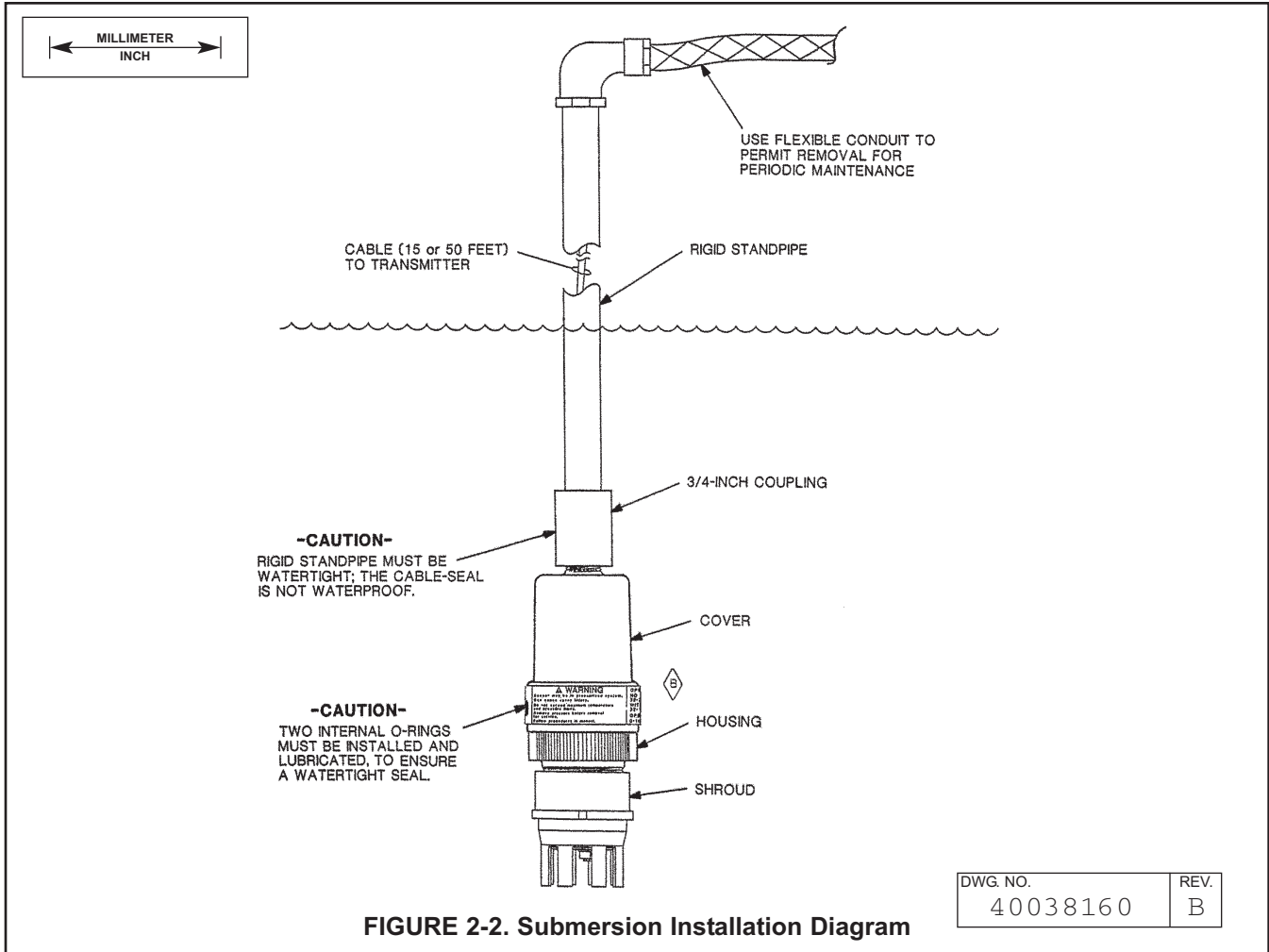

FIGURE 2-2. Submersion Installation Diagram

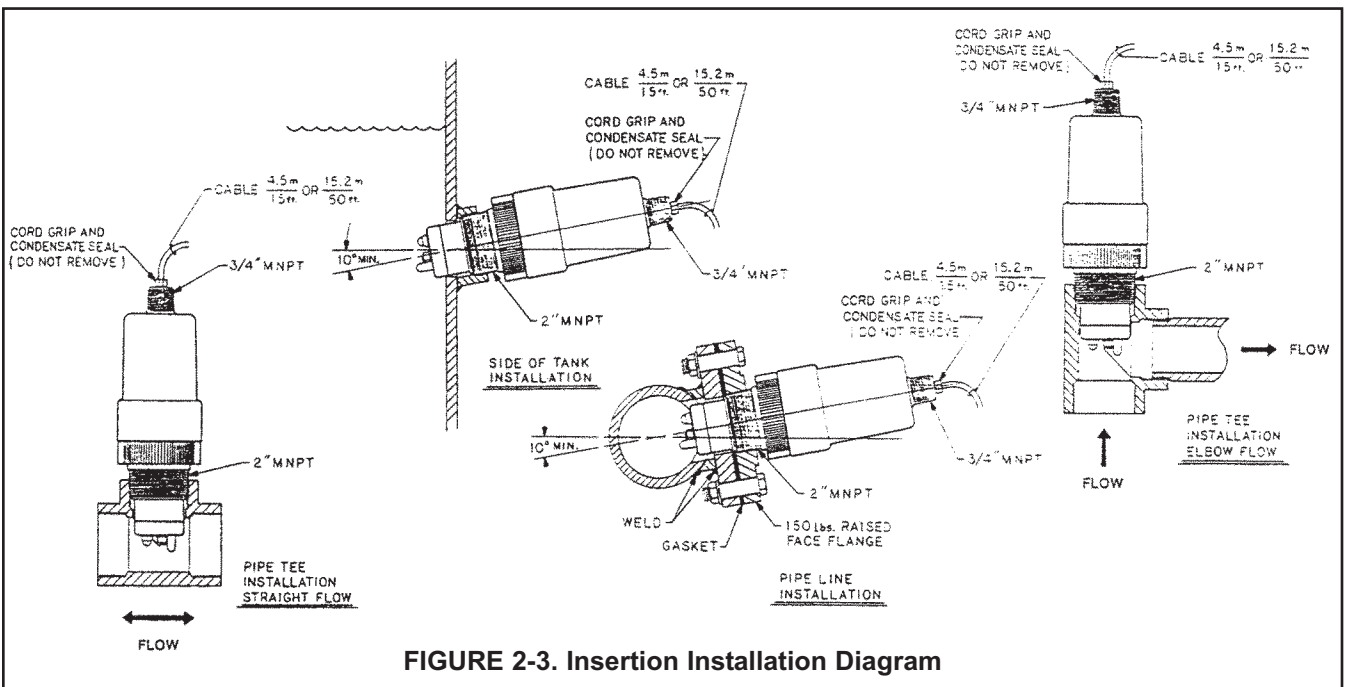

FIGURE 2-3. Insertion Installation Diagram

**2.4 FLOW THROUGH INSTALLATION (Code 03).** To install the sensor in the flow cell proceed as follows (see Figure 2-4):

1. Attach the flow cell's 1/2-inch MNPT to the sample or process line. (Note flow direction on side of flow cell.)
2. Holding the sensor with the electrode pointing up, seat the upper O-ring (PN 9550146) flush with the sensor body above the 2-inch MNPT. Lubricate with O-ring lubricant (PN 2001928).
3. With the coupling nut thread in place, thread the electrode shroud onto the sensor body (see Figure 2-4), insuring that the O-ring is properly seated and does not become pinched or twisted.

**NOTE**

The coupling nut must be inserted between the lower body assembly of the sensor and electrode shroud (see Figure 2-4).

4. Next, place the lower O-ring (PN 9550147) in the flow cell and lubricate with O-ring lubricant (PN 2001928).
5. Place sensor, coupling nut and electrode shroud in the flow cell. Insure that the O-ring is seated properly.
6. Rotate sensor until the key on electrode shroud drops into either the "open-flow" or "guarded" flow\* position.
7. Tighten the coupling nut and the flow cell fittings.

**NOTE**

Electrode shroud and coupling nut should be hand tightened only. Do not use a wrench. When tightening process or sample line connectors to the flow cell do not use a pipe wrench on the flow cell. Severe damage may result.

\* In "guarded" flow position, solid particles in the flow stream are diverted from electrode.

**2.4.1 Installation Procedures For Low Flow Conditions.** It is extremely important that the measuring electrode and liquid junction of any pH/ORP sensor remain in contact with the process fluid at all times.

Under low flow conditions or where flow fluctuations are common, sensor contact with the process fluid may be interrupted unless piping procedures are followed to prevent it.

A customer supplied valve should be installed to eliminate head pressure when the sensor is being removed from the process. This valve may also serve as a grab sample take-off point.

The installation drawing (Figure 2-5) shows the recommended piping procedures for the Model 381+ pH/ORP sensor in low flow conditions.

**2.5 FLOW POWERED CLEANER INSTALLATION (Code 04).** To install the sensor in a flow cell with flow powered cleaner, proceed as follows (see Figure 2-6);

1. Attach the flow cell's 1/2-inch MNPT to sample or process line. Note flow direction shown on the side of the flow cell.
2. Insert the ring as shown in Figure 2-6. It should snap in place.
3. Place the chamber into the flow cell. Notch must be aligned for the chamber to go in place. Place the TEFLON balls (4 each) in the chamber.
4. Follow Steps 2 through 7 in Section 2.4 for sensor installation into flow assembly (see Figure 2-4).

**2.6 WIRING.** Connect the sensor wire to the transmitter terminals as shown in Figures 2-7 through 2-13.

**NOTE**

For maximum EMI/RFI protection when wiring from the sensor to the junction box, the outer braid of the sensor should be connected to the outer braided shield of the extension cable. The outer braid of the extension cable to the instrument must be terminated at earth ground or by using an appropriate metal cable gland fitting that provides a secure connection to the instrument case.

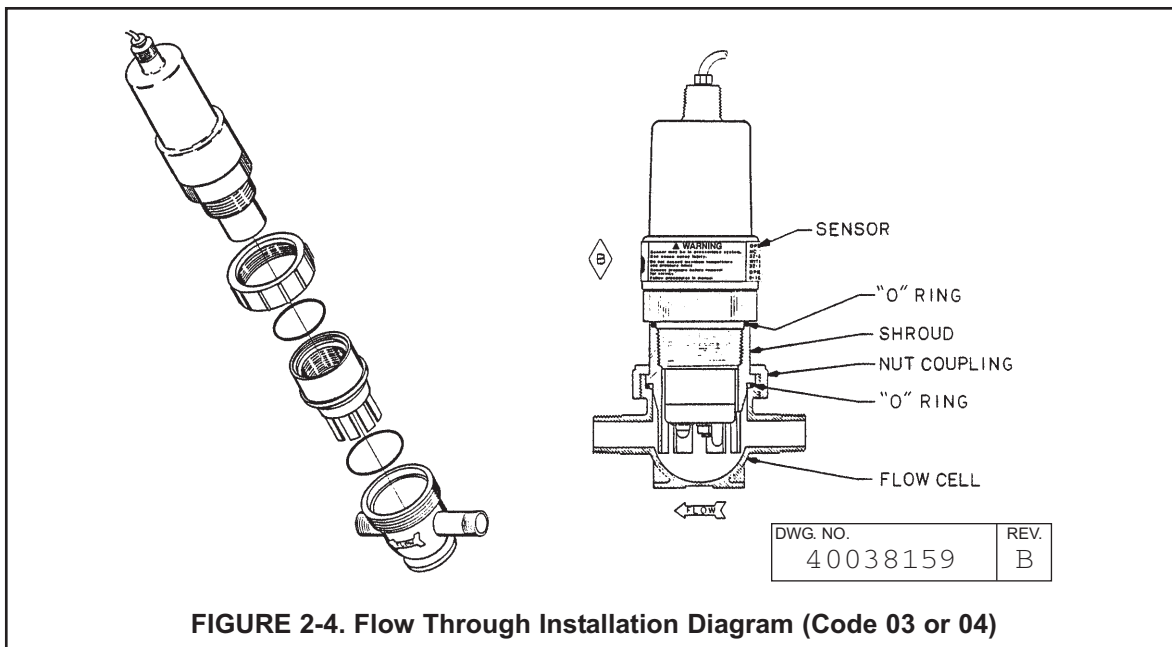

**FIGURE 2-4. Flow Through Installation Diagram (Code 03 or 04)**

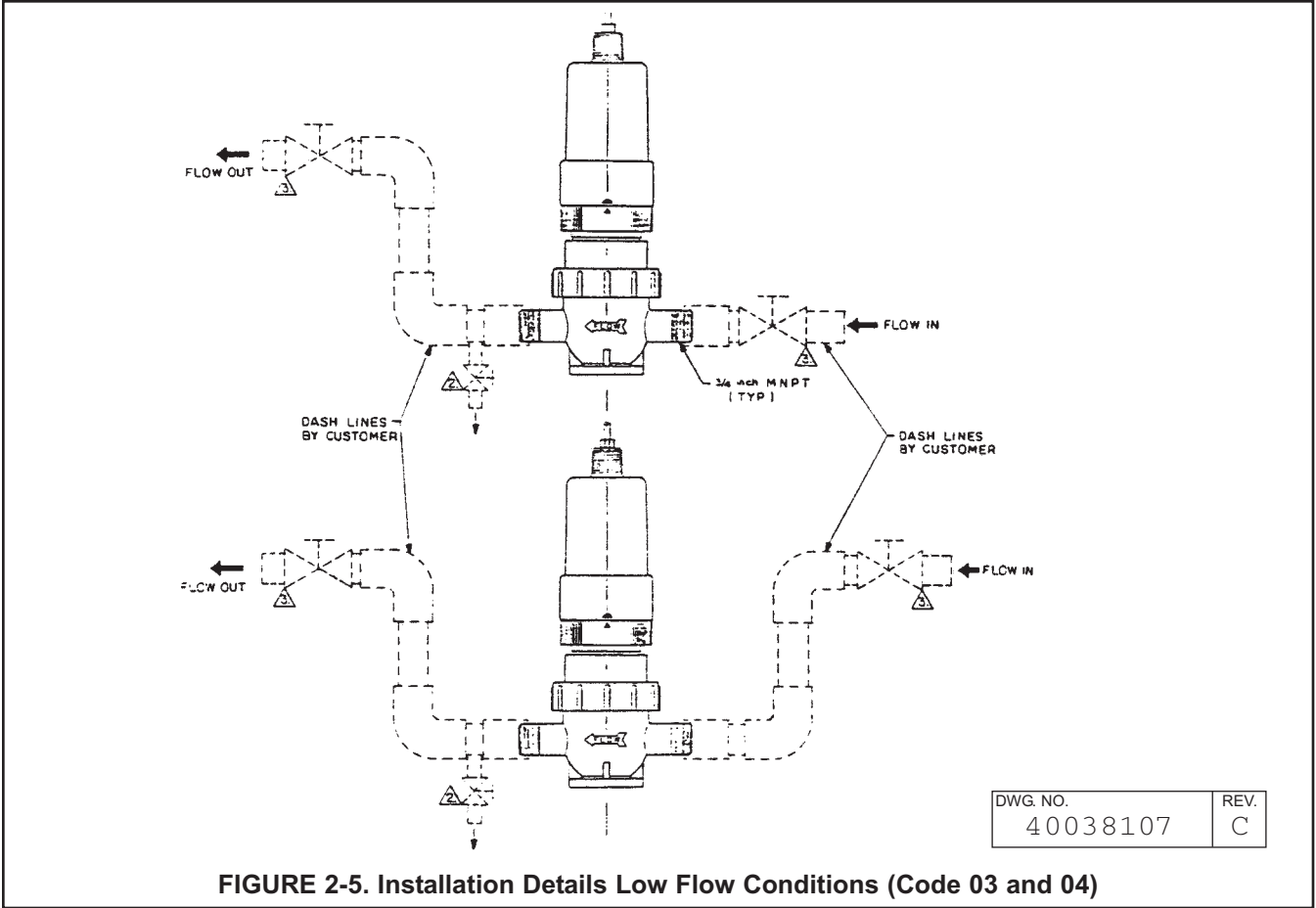

FIGURE 2-5. Installation Details Low Flow Conditions (Code 03 and 04)

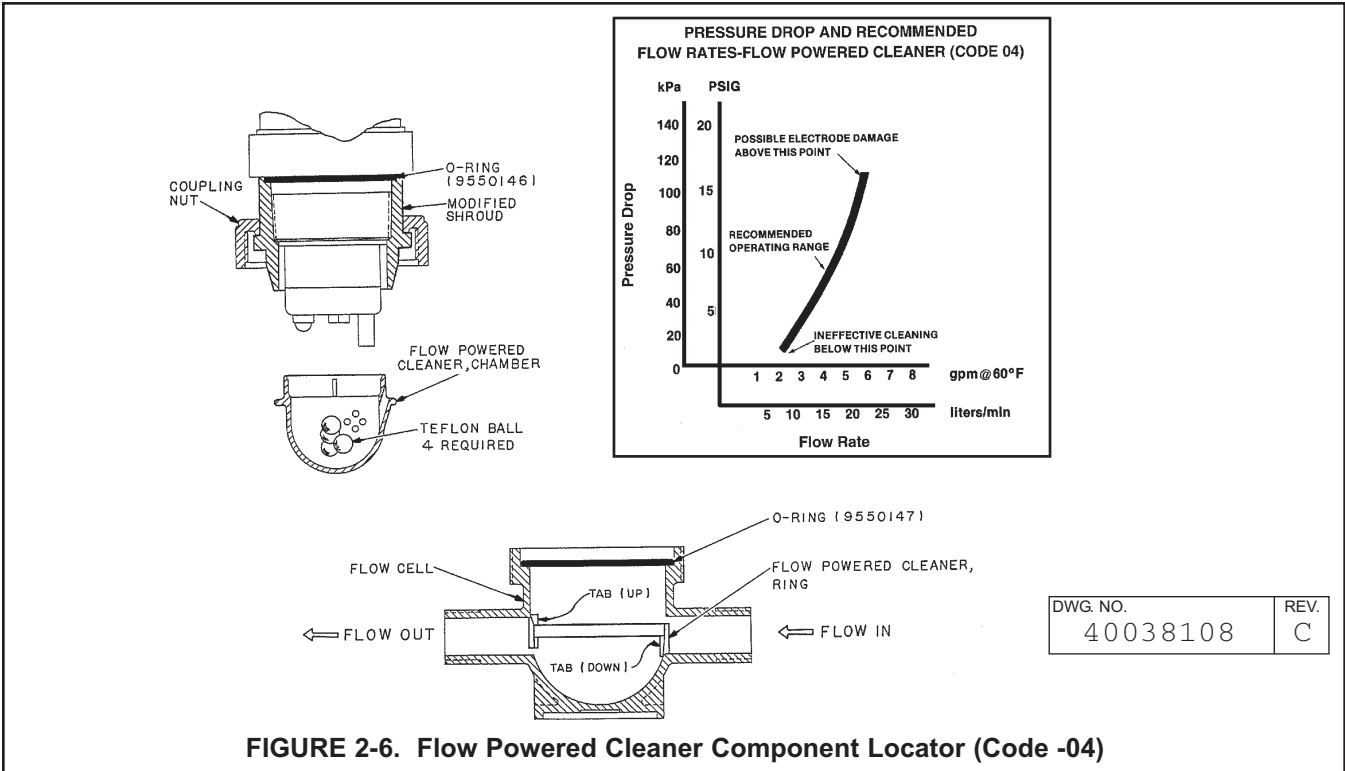

FIGURE 2-6. Flow Powered Cleaner Component Locator (Code -04)

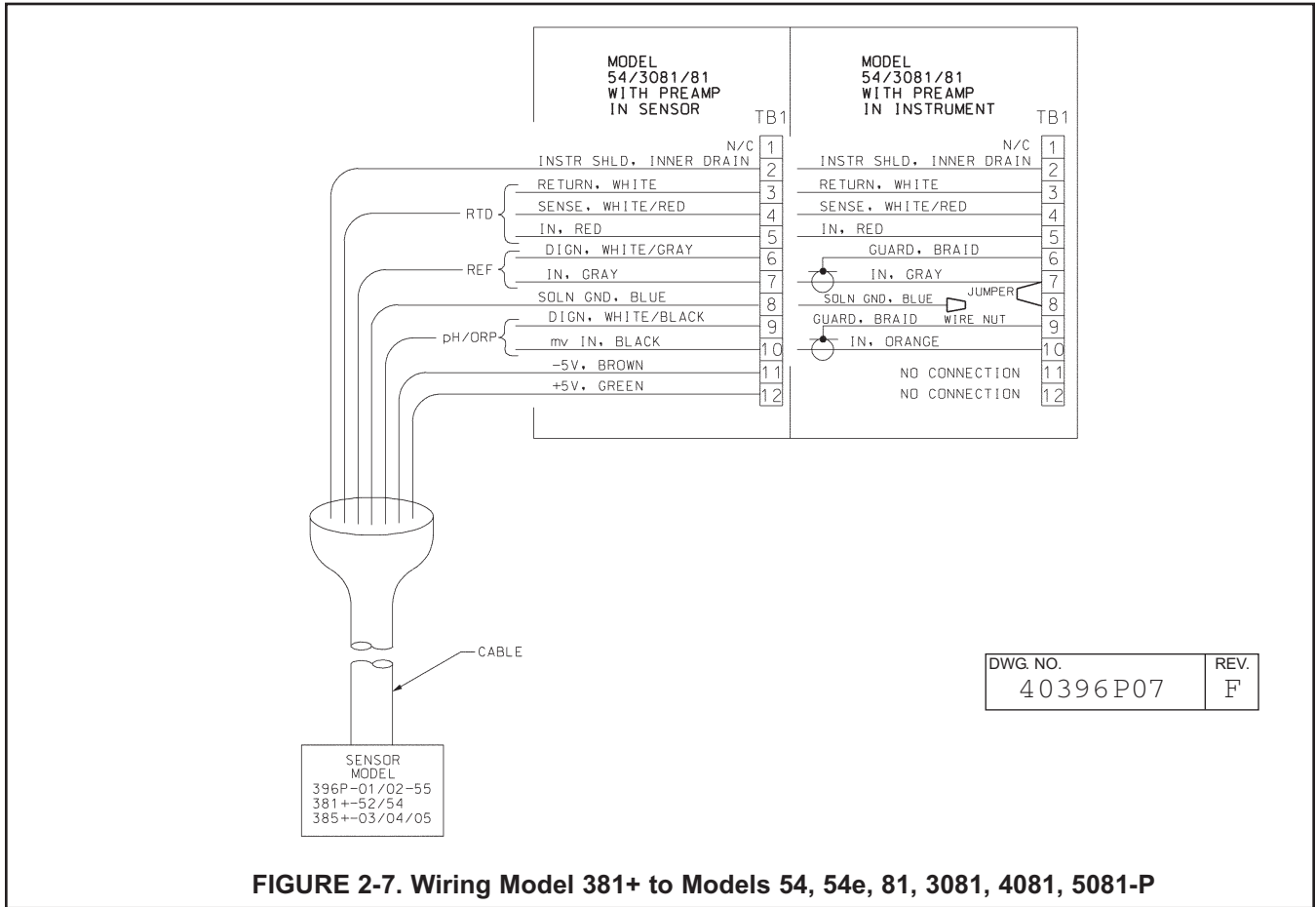

FIGURE 2-7. Wiring Model 381+ to Models 54, 54e, 81, 3081, 4081, 5081-P

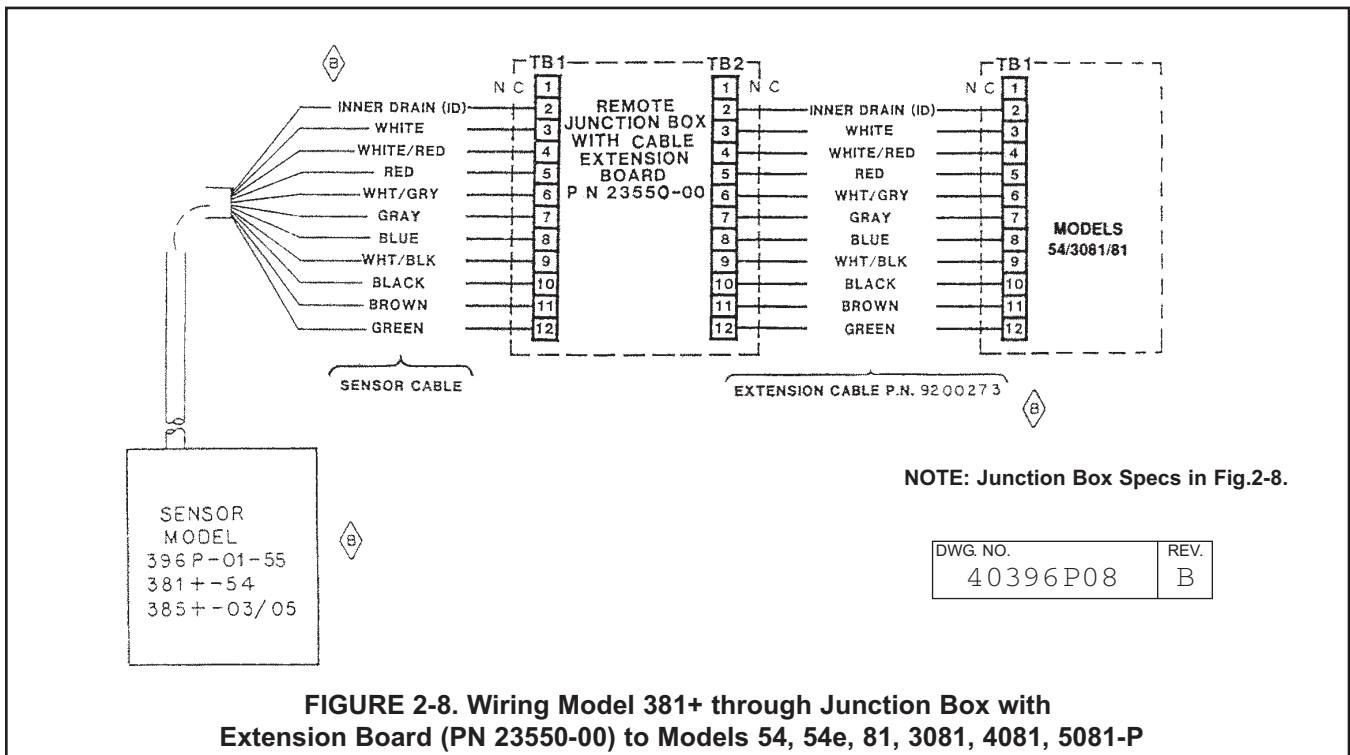

FIGURE 2-8. Wiring Model 381+ through Junction Box with Extension Board (PN 23550-00) to Models 54, 54e, 81, 3081, 4081, 5081-P



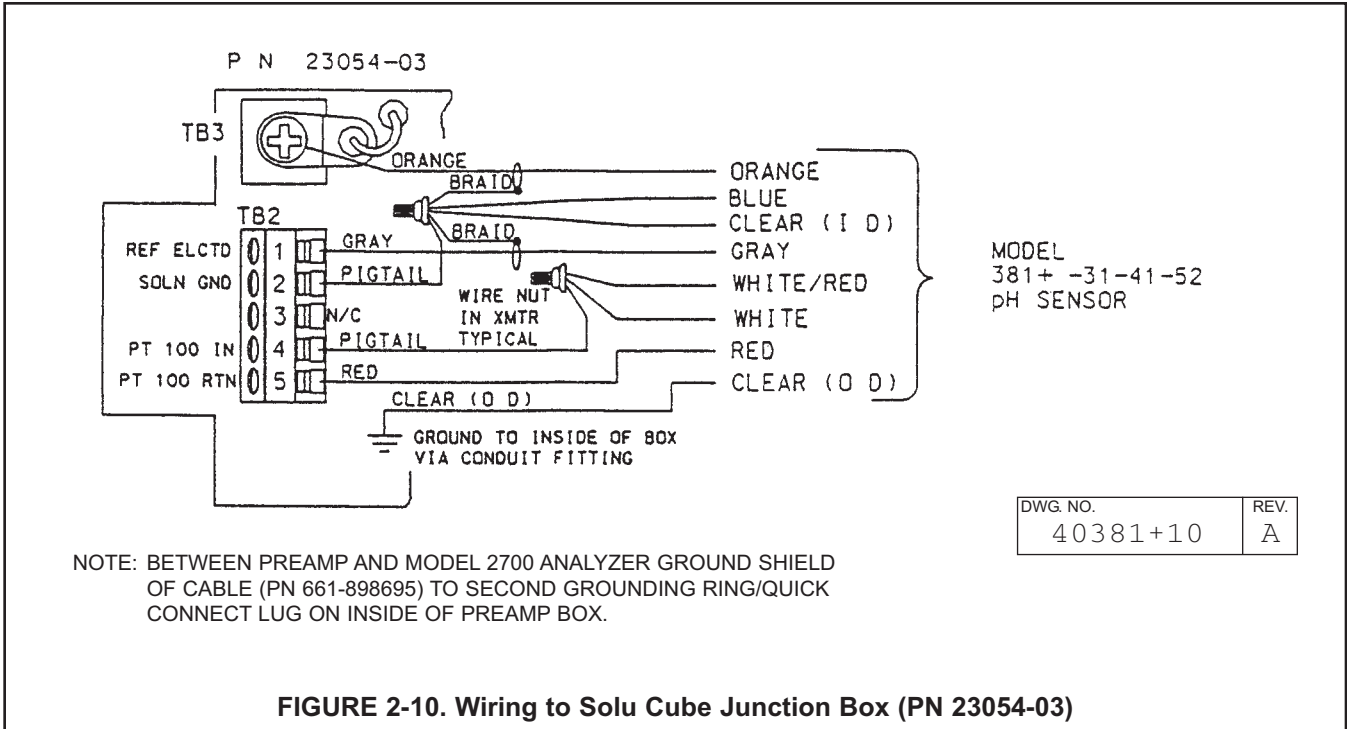

FIGURE 2-10. Wiring to Solu Cube Junction Box (PN 23054-03)

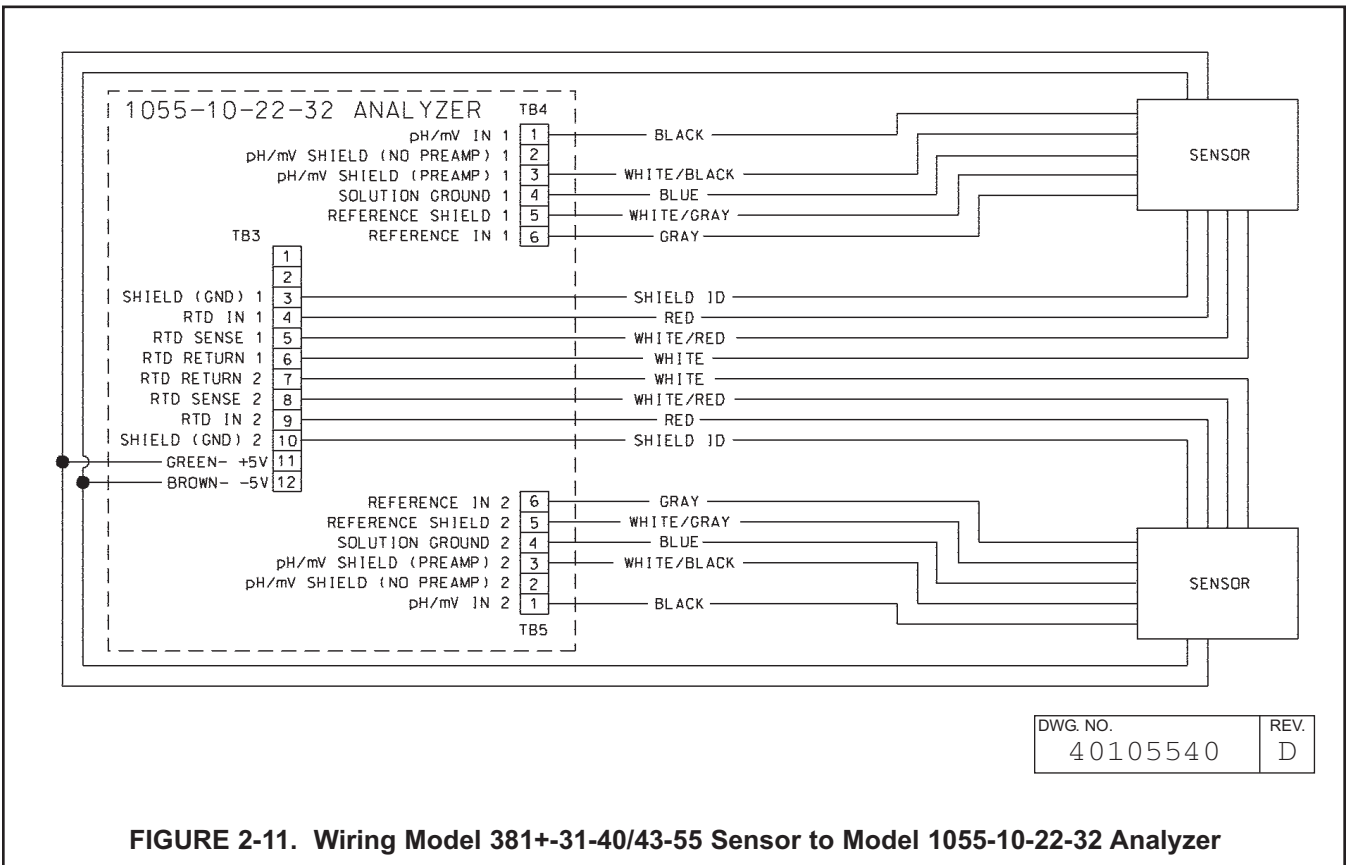
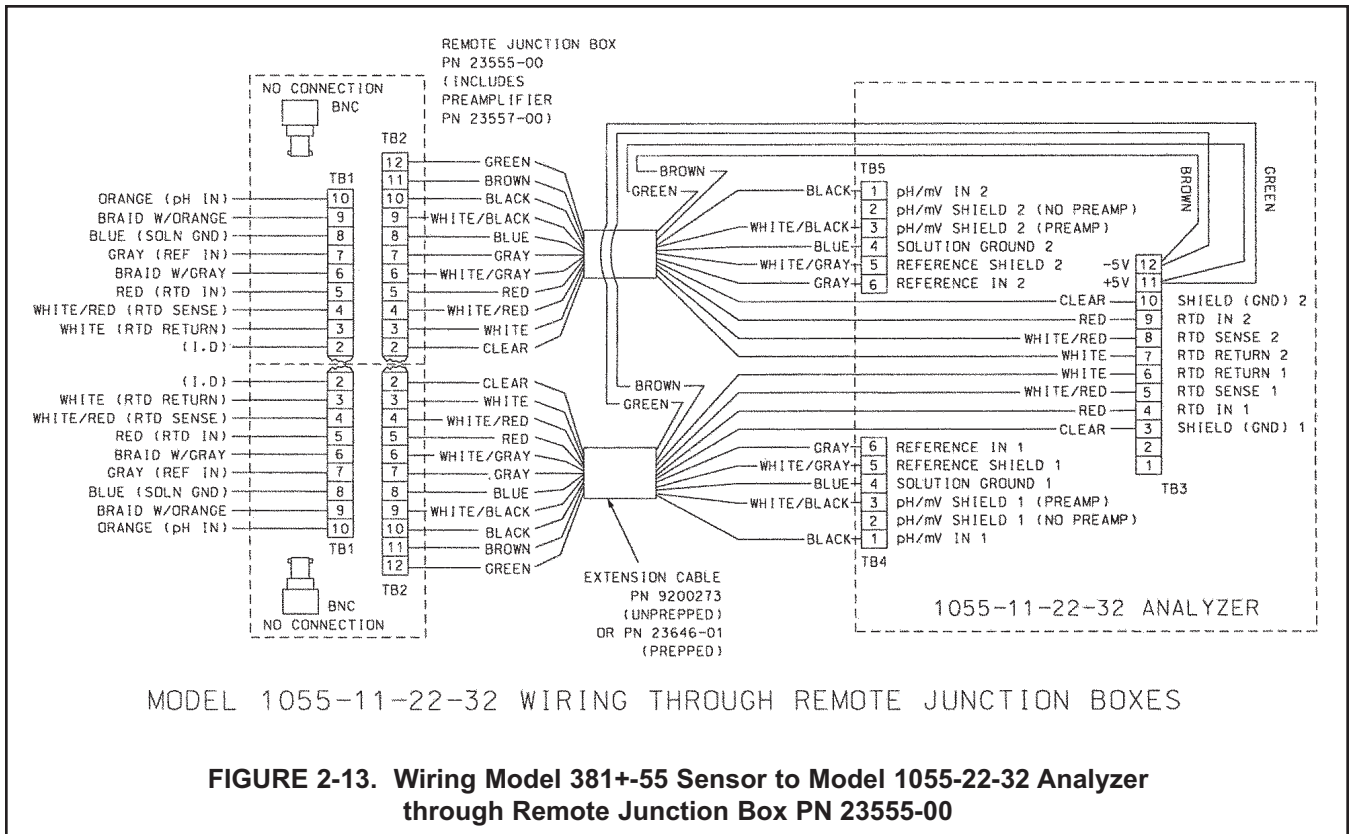
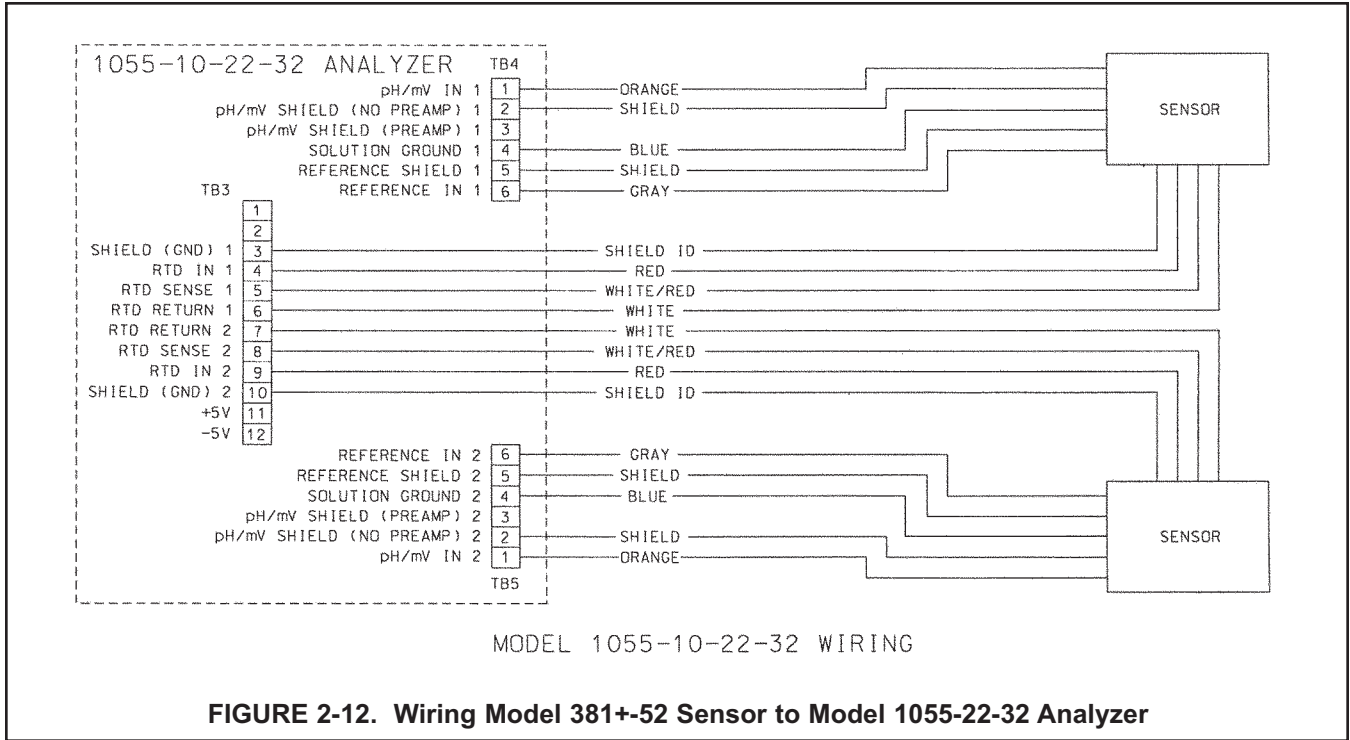
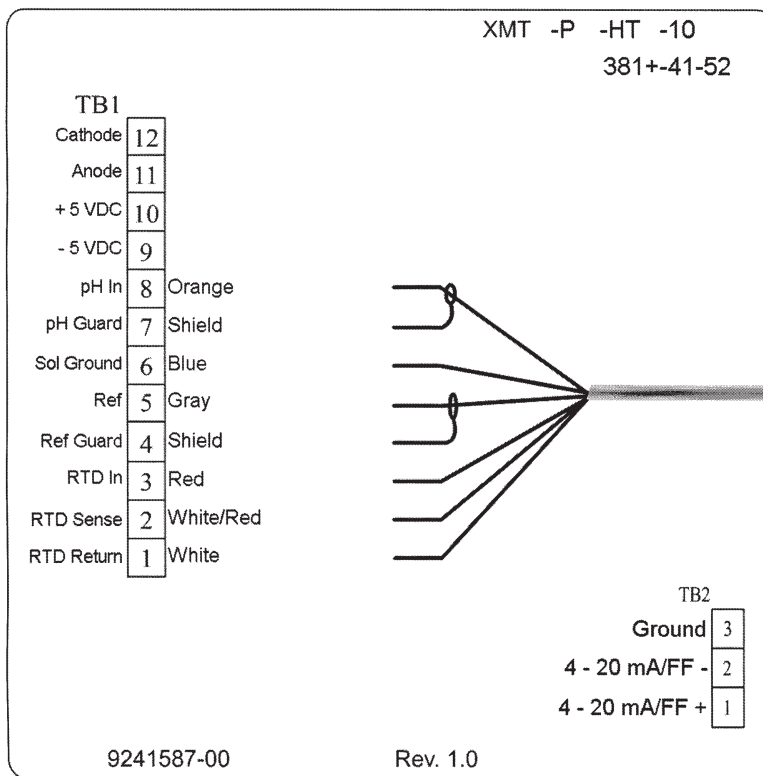

FIGURE 2-11. Wiring Model 381+-31-40/43-55 Sensor to Model 1055-10-22-32 Analyzer







**FIGURE 2-14. Wiring Model 381+-41-52 Sensor to Model Xmt-P Transmitter**

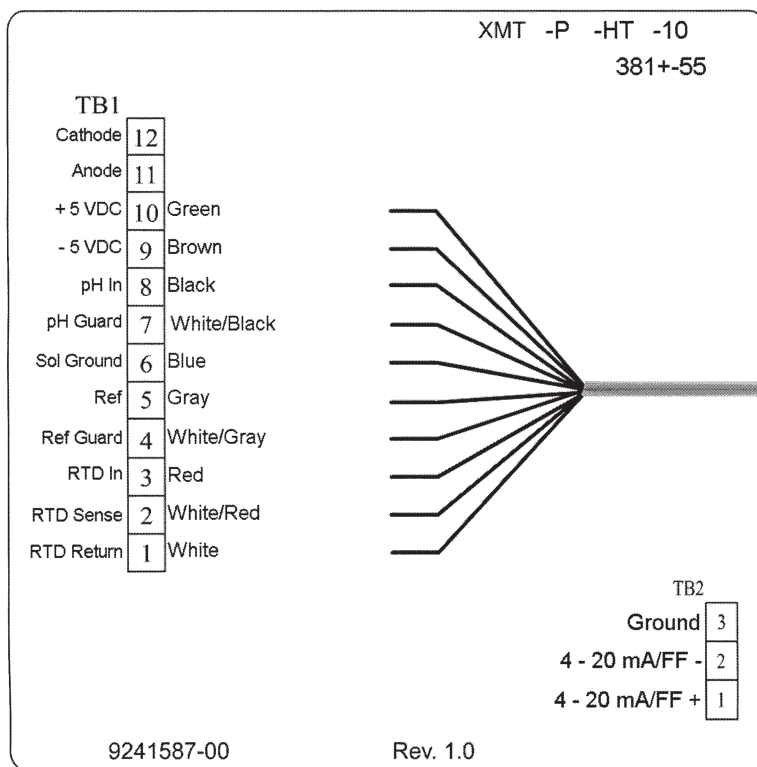

**FIGURE 2-15. Wiring Model 381+-55 Sensor to Model Xmt-P Transmitter**

## SECTION 3.0 START-UP

**3.1 START-UP.** Greater measurement accuracy may be obtained by calibrating the Model 381+ sensor and instrument as a loop. Please refer to the applicable analyzer/transmitter instruction manual for calibration procedures.

### 3.2 pH CALIBRATION

**3.2.1 Buffer Solution Method.** The Model 381+ pH sensor and analyzer/transmitter may be calibrated by immersing the sensor's measuring tip into two pH buffer solutions of different pH values (two point calibration). This is the preferred method because the analyzer can calculate the slope (efficiency) of the pH sensor.

**NOTE**

Thin film coatings on the glass electrode may cause a slight shift in calibration. Since some coating will be encountered under normal operating conditions, permit the electrode to condition itself, and perform the procedure described in Section 3.2.2, grab sample method.

**3.2.2 Grab Sample Method.** This method does not require the sensor to be removed from the process. The grab sample method is recommended immediately after and in between scheduled two point calibration procedures.

1. Take a sample of the process as close to the sensor as possible.

2. Check the sample with a calibrated portable or laboratory analyzer. This analyzer should be automatically or manually temperature compensated to the temperature of the sample being measured.
3. Refer to the analyzer/transmitter instruction manual for process standardization after buffer calibration.

**3.3 ORP STANDARDIZATION.** An ORP loop is best calibrated using an ORP standard solution method.

#### 3.3.1 Quinhydrone Solution.

**CAUTION**

The solution used during the following check is an acid and should be handled with care. Follow the directions of the acid manufacturer. Wear the proper equipment. Do not let the solution come in contact with skin or clothing. If contact with skin is made, immediately rinse with clean water.

A commonly used ORP standard solution is a saturated quinhydrone solution (PN R508-160Z). This can be made by simply adding a few quinhydrone crystals to either a 4 pH or a 7 pH buffer. Quinhydrone is only slightly soluble so only a few crystals will be required. The solution will have a yellow color. The resulting potentials should be within  $\pm 20$  millivolts of the value shown in Table 3-1. The ORP value of saturated quinhydrone solution is not stable over long periods of time and therefore new solutions should be made each time they are used.

**TABLE 3-1. ORP of Saturated Quinhydrone Solutions (in Millivolts)**

	pH 4			pH 7		
Temp. °C	20	25	30	20	25	30
Millivolt Potential	268	264	260	94	87	80

**3.3.2 Ferric-Ferrous Ammonium Sulfate Solution.** This solution offers a much more stable solution which will maintain its millivolt value for approximately one year when stored in a glass container. Rosemount Analytical offers this ORP standard as spare part number R508 for your convenience. Otherwise you can prepare the solution with the formula below.

**CAUTION**

The solution used during the following check is an acid and should be handled with care. Follow the directions of the acid manufacturer. Wear the proper equipment. Do not let the solution come in contact with skin or clothing. If contact with skin is made, immediately rinse with clean water.

To prepare solution, dissolve 39.2 grams of reagent grade ferrous ammonium sulfate [ $\text{Fe}(\text{SO}_4) \cdot (\text{NH})_2\text{SO}_4 \cdot 6\text{H}_2\text{O}$ ] and 48.2 grams of reagent grade ferric ammonium sulfate [ $\text{FeNH}_4(\text{SO})_2 \cdot 12\text{H}_2\text{O}$ ] in approximately 700 milliliters of water (distilled water is preferred, but tap water is acceptable). Slowly and carefully add 56.2 milliliters of concentrated sulfuric acid. Add sufficient water to bring the total solution volume up to 1,000 milliliters. This solution (ferric-ferrous ammonium sulfate) will produce a nominal ORP of  $476 \pm 20$  mV at 25 C. Some tolerance in mV values is to be expected due to the rather large liquid reference junction potentials which can arise when measuring this strongly acidic and concentrated solution. However, if the measuring electrodes are kept clean and in good operating condition, consistent repeatable calibrations can be achieved.

**NOTE**

Most industrial applications have a number of ORP reactions occurring in sequence or simultaneously. There can be several components that are oxidized or reduced by the reagents that are used. Theoretically, the ORP potential is absolute because it is the result of the oxidation-reduction equilibrium. However, the actual measured potential is dependent on many factors, including the condition of the surface of the ORP platinum electrode. Therefore, the sensor should be allowed 1-2 hours to become "conditioned" to the stream to be measured when first setting up or after being cleaned.

## SECTION 4.0 MAINTENANCE

**4.1 GENERAL.** The Model 381+ sensor requires periodic cleaning and calibration. Since this sensor is rebuildable, components may be replaced as required.

### 4.2 SENSOR REMOVAL.

**! WARNING !**  
BEFORE REMOVING THE SENSOR, be absolutely certain that the process pressure is reduced to 0 psig and the process temperature is lowered to a safe level!

Remove the sensor from the process for cleaning, calibration or component replacement.

### 4.3 MONTHLY MAINTENANCE.

**4.3.1 pH Electrode Cleaning.** If the electrode is coated or dirty, it may be cleaned as follows:

1. Remove the sensor from process as instructed in Section 4.2.
2. Wipe the glass bulb with a soft, clean, lint free cloth or tissue. If this does not remove the dirt or coating, proceed to step 3. If the sensor appears to be clean, go to step 5.
3. Wash the glass bulb in a strong detergent solution and thoroughly rinse with tap water. If the bulb still appears to have a coating, proceed to step 4.

#### CAUTION

The solution used in the following step is an acid and should be handled with care. Follow the directions of the acid manufacturer. Wear the proper protective equipment. Do not let the solution come in contact with skin or clothing. If contact with the skin is made, immediately rinse with clean water.

4. If step 3 does not clean the electrode tip, remove the glass electrode from the sensor body. Following the caution above, wash the glass electrode bulb in dilute 5% hydrochloric acid solution and then rinse it thoroughly in tap water. Replace the glass electrode if it cannot be cleaned. Install the clean or new glass electrode into the Model 381+ sensor body and proceed to step 5.

5. Buffer calibrate the sensor (Refer to Section 3.0). If the sensor appears to respond sluggishly to pH change, soaking it overnight in a weak acid solution (5% hydrochloric acid) may improve its response. Be sure to follow the CAUTION above and to rinse the sensor's tip thoroughly with tap water. If the sensor will not calibrate, it must be replaced.

**4.3.2 Cleaning Platinum Electrode.** The electrode can be restored to normal operation by simply cleaning the platinum electrode with baking soda. Polish it by rubbing it with a damp paper towel and baking soda until a bright, shiny appearance is attained.

### 4.4 ANNUAL MAINTENANCE.

1. Remove the sensor from the process.
2. While holding the sensor in an upright position, remove and discard the liquid junction.
3. Drain the solution from the sensor body and rinse the inside of the body with clean, warm water.
4. Remove the cover from the body by grasping the body and rotating the cover  $\pi$ -turn in the counter-clockwise direction.
5. When the cover breaks loose from the body, pull straight out on the cover and disconnect the cable connector from the preamplifier.
6. Disconnect the electrode BNC connector from the preamplifier or remote connector and then unplug the preamplifier or remote connector from the sensor body.
7. Remove and discard the microjunction reference electrode.

8. Remove and discard the O-rings on the body.
9. Install a new microjunction reference electrode in the body.
10. Make sure the upper and lower body O-ring sealing surfaces are clean, and lubricate the new O-rings with O-ring lubricant (PN 2001928). Install the O-rings making sure they are not twisted.
11. Install the preamplifier or remote connector on the sensor body and make sure all connections are secure and that both O-rings are in place.
12. Install the cover on the sensor body so the threads will engage.
13. Rotate the cover until the triangle on the sensor body aligns with (or falls within) the adjacent mark on the cover.

**CAUTION**

DO NOT use a pipe wrench on the body or cover. Severe damage could result.

14. While holding the sensor in an upside down position, fill the reference chamber in the body (through the liquid junction opening) with gel solution (PN 9210342). Care must be taken to remove as much air as possible from the reference cell.

**CAUTION**

DO NOT use pipe joint compound or pipe dope on the threads of the liquid junction. The electrical circuit will be disrupted if the liquid junction is contaminated

15. Wrap TEFLON tape on a new liquid junction and install the liquid junction in the body.
16. Calibrate the sensor per Section 3.0. Install the sensor as described in Section 2.0.

**NOTE**

Flow-through sensor (Codes 03 & 04). Upper and lower flow cell O-rings should be replaced at this time. Lubricate new O-rings with O-ring lubricant (PN 2001928) and reinstall sensor as described in Section 2.4 and Section 2.5.

**4.5 ELECTRODE CHECKING AND STANDARDIZATION.** Refer to Section 3.2 or Section 3.3 for pH or ORP electrode checking, start-up and standardization.

## SECTION 5.0 TROUBLESHOOTING

**5.1 SENSOR TROUBLESHOOTING.** In the event of a malfunction, refer to Table 5-1 below. This table lists the Models 54, 54e, 81, 3081, 4081, 5081, and Xmt diagnostic messages, description of the problem and remedy for the Model 381+ pH/ORP sensor. Refer to instrument's instruction manual for screen displays.

**TABLE 5-1. Troubleshooting**

DIAGNOSTIC MESSAGE	DESCRIPTION OF PROBLEM	REMEDY
"Calibration Warning"	1. Aged glass 2. Sensor not immersed	1. Perform buffer calibration 2. Be sure electrode measuring tip is in process
"Cracked glass failure"	Broken or cracked glass	Replace Sensor
"High reference impede"	1. Liquid junction coated 2. Reference Cell gel depleted 3. Sensor not immersed	1. Clean sensor; replace if necessary 2. Replace sensor 3. Be sure electrode measuring tip is in process
"Input voltage high" "Input voltage low"	pH input shorted or sensor miswired	Check wiring. Replace sensor if necessary
"Old glass warning"	1. Glass electrode worn out 2. Sensor not immersed	1. Replace sensor 2. Be sure electrode measuring tip is in process
"Reference offset err" (offline only)	Reference electrode poisoned	Replace sensor
"Ref voltage high" "Ref voltage low"	Reference shorted or sensor miswired	Check wiring. Replace sensor if necessary
"Sensor line open"	1. Open wire between sensor and analyzer 2. Interconnecting cable greater than 1000 ft.	1. Check sensor wiring 2. Relocate analyzer
"Sensor miswired"	1. Open wire between sensor and analyzer 2. Bad preamplifier	1. Check wiring 2. Replace preamplifier
"Temp error high"	1. Open or shorted RTD	1. Replace sensor

**5.2 T.C. ELEMENT EVALUATION.** Table 5-2, below, is a ready reference of RTD resistance values at various temperatures. These values may be used for test and evaluation of the sensor.

<b>TABLE 5-2. T.C. Element Resistance</b>	
<b>Temp °C</b>	<b>Resistance (±1%)</b>
	100 ohm
0	100.00 ohms
10	103.90 ohms
20	107.79 ohms
25	109.73 ohms
30	111.67 ohms
40	115.54 ohms
50	119.40 ohms
60	123.24 ohms
70	127.07 ohms
80	130.89 ohms
90	134.70 ohms
100	138.50 ohms

To check the 100 ohm T.C. element, proceed as follows:

1. Using an ohmmeter, check the resistance at the body or between the red and white wires of the sensor cable with the transmitter disconnected.
2. The resistance shall agree with the resistance shown in Table 5-2.
3. The T.C. element resistance for other temperatures may be calculated as follows: Each degree difference equals 0.385 ohm.

**NOTE**

Ohmic values are read across the RTD element and are based on the manufacturers stated value of ±1%. Allow enough time for the RTD element to stabilize to the surrounding temperature.

## SECTION 6.0 RETURN OF MATERIAL

**6.1 GENERAL.** To expedite the repair and return of instruments, proper communication between the customer and the factory is important. A return material authorization number is required. Call 1-800-654-7768 or (949) 757-8500. The "Return of Materials Request" form is provided for you to copy and use in case the situation arises. The accuracy and completeness of this form will affect the processing time of your materials.

**6.2 WARRANTY REPAIR.** The following is the procedure for returning products still under warranty.

1. Contact the factory for authorization.
2. Complete a copy of the "Return of Materials Request" form as completely and accurately as possible.
3. To verify warranty, supply the factory sales order number or the original purchase order number. In the case of individual parts or sub-assemblies, the serial number on the unit must be supplied.
4. Carefully package the materials and enclose your "Letter of Transmittal" and the completed copy of the "Return of Materials Request" form. If possible, pack the materials in the same manner as it was received.

### IMPORTANT

Please see second section of "Return of Materials Request Form". Compliance to the OSHA requirements is mandatory for the safety of all personnel. MSDS forms and a certification that the instruments have been disinfected or detoxified are required.

5. Send the package prepaid to:

Rosemount Analytical Inc.  
2400 Barranca Parkway  
Irvine, CA 92606

Attn: Factory Repair

Mark the package: Returned for

Repair RMA No. \_\_\_\_\_

Model No. \_\_\_\_\_

### 6.3 NON-WARRANTY REPAIR.

1. Contact the factory for authorization.
2. Fill out a copy of the "Return of Materials Request" form as completely and accurately as possible.
3. Include a purchase order number and make sure to include the name and telephone number of the right individual to be contacted should additional information be needed.
4. Do Steps 4 and 5 of Section 6.2.

### NOTE

Consult the factory for additional information regarding service or repair.



# RETURN OF MATERIALS REQUEST

**•IMPORTANT!**

This form must be completed to ensure expedient factory service.

<b>C U S T O M E R</b>	<b>FROM: RETURN</b>	<b>BILL TO:</b>	
	_____	_____	_____
	_____	_____	_____

**NOTICE TO SENDERS:** **CUSTOMER/USER MUST SUBMIT MATERIAL SAFETY SHEET (MSDS)** OR COMPLETE STREAM COMPOSITION, AND/OR LETTER CERTIFYING THE MATERIALS HAVE BEEN DISINFECTED AND/OR DETOXIFIED WHEN RETURNING ANY PRODUCT, SAMPLE OR MATERIAL THAT HAVE BEEN EXPOSED TO OR USED IN AN ENVIRONMENT OR PROCESS THAT CONTAINS A HAZARDOUS MATERIAL **ANY OF THE ABOVE THAT IS SUBMITTED TO ROSEMOUNT ANALYTICAL WITHOUT THE MSDS WILL BE RETURNED TO SENDER C.O.D.** FOR THE SAFETY AND HEALTH OF OUR EMPLOYEES. WE THANK YOU IN ADVANCE FOR COMPLIANCE TO THIS SUBJECT.

**SENSOR OR CIRCUIT BOARD ONLY:**  
(Please reference where from in MODEL / SER. NO. Column)

1. PART NO. _____	1. MODEL _____	1. SER. NO. _____
2. PART NO. _____	2. MODEL _____	2. SER. NO. _____
3. PART NO. _____	3. MODEL _____	3. SER. NO. _____
4. PART NO. _____	4. MODEL _____	4. SER. NO. _____

**REASON FOR RETURN:** **PLEASE CHECK ONE:**

REPAIR AND CALIBRATE
  DEMO EQUIPMENT NO. \_\_\_\_\_  
 EVALUATION
  OTHER (EXPLAIN) \_\_\_\_\_  
 REPLACEMENT REQUIRED?  YES  NO

DESCRIPTION OF MALFUNCTION:

\_\_\_\_\_

\_\_\_\_\_

\_\_\_\_\_

**REPAIR STATUS:** **WARRANTY REPAIR REQUESTED:**

YES-REFERENCE ORIGINAL ROSEMOUNT ANALYTICAL ORDER NO. \_\_\_\_\_  
 CUSTOMER PURCHASE ORDER NO. \_\_\_\_\_  
 NO-PROCEED WITH REPAIRS-INVOICE AGAINST P.O. NO. \_\_\_\_\_  
 NO-CONTACT WITH ESTIMATE OF REPAIR CHARGES: LETTER  \_\_\_\_\_  
 PHONE  \_\_\_\_\_

NAME \_\_\_\_\_ PHONE \_\_\_\_\_

ADDRESS \_\_\_\_\_

\_\_\_\_\_ ZIP \_\_\_\_\_

**RETURN AUTHORITY FOR CREDIT ADJUSTMENT [Please check appropriate box(s)]**

WRONG PART RECEIVED
  REPLACEMENT RECEIVED  
 DUPLICATE SHIPMENT
 REFERENCE ROSEMOUNT ANALYTICAL SALES ORDER NO. \_\_\_\_\_  
 RETURN FOR CREDIT
 **RETURN AUTHORIZED BY:** \_\_\_\_\_  
 WARRANTY DEFECT \_\_\_\_\_  
 \_\_\_\_\_

24-6047

**Emerson Process Management**  
**Liquid Division**  
 2400 Barranca Parkway  
 Irvine, CA 92606 USA  
 Tel: (949) 757-8500  
 Fax: (949) 474-7250  
<http://www.raihome.com>



**The right people, the right answers, right now.**

## **Immediate, Reliable Analytical Support**

Now there's a way to quickly get the right answers for your liquid analytical instrumentation questions: the Analytical Customer Support Center.

Our staff of trained professionals is ready to provide the information you need. If you are placing an order, verifying delivery, requesting application information, or just want to contact an Emerson Process Management representative, a call to the Customer Support Center will provide you with the right people, the right answers, right now.

### **THE AMERICAS - HEADQUARTERS**

Emerson Process Management  
Rosemount Analytical Inc.  
Liquid Center of Excellence  
2400 Barranca Parkway  
Irvine, CA 92606  
Phone: +1.949.757.8500  
Toll Free: +1.800.854.8257  
Fax: +1.949.474.7250

### **GERMANY**

Emerson Process Management  
Process Gas Analyzer Center of  
Excellence  
GmbH & Co. OHG  
Industriestrasse 1  
63594 Hasselroth  
Germany  
T 49.6055.884.0  
F 49.6055.884.20

### **ASIA-PACIFIC**

Emerson Process Management  
Asia Pacific Private Ltd.  
1 Pandan Crescent  
Singapore 0512  
Republic of Singapore  
Phone: 65.777.8211  
Fax: 65.777.0947

### **LATIN AMERICA**

Emerson Process Management  
Rosemount Analytical  
10241 West Little York, Suite  
#200 Houston, TX 77040 USA  
T 713.467.6000  
F 713.827.3328

### **EUROPE**

Emerson Process Management  
Heath Place  
Bognor Regis  
West Sussex PO22 9SH  
England  
Phone: 44.1243.863121  
Fax: 44.1243.845354

### **MIDDLE EAST AND AFRICA**

Emerson Process Management  
EPM Building  
P. O. Box 17033  
Jebe Ali Free Zone  
Dubai, United Arab Emirates  
T 971.4.8835235  
F 971.4.8835312

**VISIT OUR WEBSITE AT**  
***[www.rosemountanalytical.com](http://www.rosemountanalytical.com)***

## WARRANTY

Seller warrants that the firmware will execute the programming instructions provided by Seller, and that the Goods manufactured or Services provided by Seller will be free from defects in materials or workmanship under normal use and care until the expiration of the applicable warranty period. Goods are warranted for twelve (12) months from the date of initial installation or eighteen (18) months from the date of shipment by Seller, whichever period expires first. **Consumables, such as glass electrodes, membranes, liquid junctions, electrolyte, o-rings, catalytic beads, etc., and Services are warranted for a period of 90 days from the date of shipment or provision.**

Products purchased by Seller from a third party for resale to Buyer ("Resale Products") shall carry only the warranty extended by the original manufacturer. Buyer agrees that Seller has no liability for Resale Products beyond making a reasonable commercial effort to arrange for procurement and shipping of the Resale Products.

If Buyer discovers any warranty defects and notifies Seller thereof in writing during the applicable warranty period, Seller shall, at its option, promptly correct any errors that are found by Seller in the firmware or Services, or repair or replace F.O.B. point of manufacture that portion of the Goods or firmware found by Seller to be defective, or refund the purchase price of the defective portion of the Goods/Services.

All replacements or repairs necessitated by inadequate maintenance, normal wear and usage, unsuitable power sources, unsuitable environmental conditions, accident, misuse, improper installation, modification, repair, storage or handling, or any other cause not the fault of Seller are not covered by this limited warranty, and shall be at Buyer's expense. Seller shall not be obligated to pay any costs or charges incurred by Buyer or any other party except as may be agreed upon in writing in advance by an authorized Seller representative. All costs of dismantling, reinstallation and freight and the time and expenses of Seller's personnel for site travel and diagnosis under this warranty clause shall be borne by Buyer unless accepted in writing by Seller.

Goods repaired and parts replaced during the warranty period shall be in warranty for the remainder of the original warranty period or ninety (90) days, whichever is longer. This limited warranty is the only warranty made by Seller and can be amended only in a writing signed by an authorized representative of Seller. Except as otherwise expressly provided in the Agreement, THERE ARE NO REPRESENTATIONS OR WARRANTIES OF ANY KIND, EXPRESS OR IMPLIED, AS TO MERCHANTABILITY, FITNESS FOR PARTICULAR PURPOSE, OR ANY OTHER MATTER WITH RESPECT TO ANY OF THE GOODS OR SERVICES.

## RETURN OF MATERIAL

Material returned for repair, whether in or out of warranty, should be shipped prepaid to:

**Emerson Process Management  
2400 Barranca Parkway  
Irvine, CA 92606**

The shipping container should be marked:

Return for Repair

Model \_\_\_\_\_

The returned material should be accompanied by a letter of transmittal which should include the following information (make a copy of the "Return of Materials Request" found on the last page of the Manual and provide the following thereon):

1. Location type of service, and length of time of service of the device.
2. Description of the faulty operation of the device and the circumstances of the failure.
3. Name and telephone number of the person to contact if there are questions about the returned material.
4. Statement as to whether warranty or non-warranty service is requested.
5. Complete shipping instructions for return of the material.

Adherence to these procedures will expedite handling of the returned material and will prevent unnecessary additional charges for inspection and testing to determine the problem with the device.

If the material is returned for out-of-warranty repairs, a purchase order for repairs should be enclosed.



*The right people,  
the right answers,  
right now.*

ROSEMOUNT ANALYTICAL  
CUSTOMER SUPPORT CENTER  
1-800-854-8257

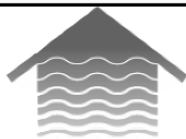

### Emerson Process Management

2400 Barranca Parkway  
Irvine, CA 92606 USA  
Tel: (949) 757-8500  
Fax: (949) 474-7250

<http://www.rosemountanalytical.com>

© Rosemount Analytical Inc. 2012

ON-LINE ORDERING NOW AVAILABLE ON OUR WEB SITE  
<http://www.rosemountanalytical.com>

*Specifications subject to change without notice.*



Credit Cards for U.S. Purchases Only.

