

Instruction Manual

IB-102-202N Rev. 1.2

January 2003

Hagan 2-1/2 x 5

Thrust Type, Swivel Mounted
Pneumatic Power Positioner



ROSEMOUNT[®]
Analytical

<http://www.processanalytic.com>

EMERSON[™]
Process Management

ESSENTIAL INSTRUCTIONS

READ THIS PAGE BEFORE PROCEEDING!

Rosemount Analytical designs, manufactures and tests its products to meet many national and international standards. Because these instruments are sophisticated technical products, you **MUST properly install, use, and maintain them** to ensure they continue to operate within their normal specifications. The following instructions **MUST be adhered to** and integrated into your safety program when installing, using, and maintaining Rosemount Analytical products. Failure to follow the proper instructions may cause any one of the following situations to occur: Loss of life; personal injury; property damage; damage to this instrument; and warranty invalidation.

- **Read all instructions** prior to installing, operating, and servicing the product.
- If you do not understand any of the instructions, **contact your Rosemount Analytical representative** for clarification.
- **Follow all warnings, cautions, and instructions** marked on and supplied with the product.
- **Inform and educate your personnel in the proper installation, operation, and maintenance of the product.**
- **Install your equipment as specified in the Installation Instructions of the appropriate Instruction Manual and per applicable local and national codes.** Connect all products to the proper electrical and pressure sources.
- To ensure proper performance, **use qualified personnel** to install, operate, update, program, and maintain the product.
- When replacement parts are required, ensure that qualified people use replacement parts specified by Rosemount. Unauthorized parts and procedures can affect the product's performance, place the safe operation of your process at risk, **and VOID YOUR WARRANTY.** Look-alike substitutions may result in fire, electrical hazards, or improper operation.
- **Ensure that all equipment doors are closed and protective covers are in place, except when maintenance is being performed by qualified persons, to prevent electrical shock and personal injury.**

The information contained in this document is subject to change without notice.

Emerson Process Management

Rosemount Analytical Inc.

Process Analytic Division

1201 N. Main St.

Orrville, OH 44667-0901

T (330) 682-9010

F (330) 684-4434

e-mail: gas.csc@EmersonProcess.com

<http://www.processanalytic.com>



HIGHLIGHTS OF CHANGES

Effective May, 1995 Rev. 1

Page	Summary
Page 2-2	Figure 2-1. Added a callout regarding placement of positioner arm in relation to pilot valve.
Page 2-1	Added paragraph 2-2. Mounting regarding the correct positional relationship of the arm, calibration spring, and pilot valve.
Page 7-1	Tables 7-1 and 7-2, Added "Maintenance Tool Kit" to both lists of recommended spare parts.

Effective April, 2001 Rev. 1.1

Page	Summary
Page 4-2	Added NOTE 4 to Figure 4-1.

Effective January, 2003 Rev. 1.2

Page	Summary
Page 7-1	Corrected figure and index numbers for top and bottom diaphragms.
Page 7-3	Added part number for Limit Switch Field Retrofit Kit. Removed part numbers for individual kit part.

TABLE OF CONTENTS

PREFACE.....	P-1
Definitions.....	P-1
Safety Instructions.....	P-2
1-0 DESCRIPTION.....	1-1
1-1 Scope.....	1-1
1-2 Package Contents.....	1-1
1-3 Equipment Description.....	1-1
2-0 INSTALLATION AND ADJUSTMENTS.....	2-1
2-1 Location.....	2-1
2-2 Mounting.....	2-1
2-3 Air Connections.....	2-1
2-4 Wiring.....	2-4
2-5 Adjustment of Standard Units.....	2-4
2-6 Adjustment of On/Off Units.....	2-6
2-7 Adjustment of Optional Limit Switches.....	2-6
3-0 THEORY OF OPERATION.....	3-1
3-1 Standard Unit.....	3-1
3-2 On/Off Standard Option.....	3-3
4-0 MAINTENANCE AND SERVICE.....	4-1
4-1 Scheduled Maintenance of Standard Units.....	4-1
4-2 Scheduled Maintenance of On/Off Units.....	4-3
4-3 Repairs to Control System.....	4-5
4-4 Repairs to Cylinder Assembly (Standard and On/Off).....	4-5
4-5 Installation of Limit Switches.....	4-7
5-0 TROUBLESHOOTING.....	5-1
5-1 Troubleshooting Standard Units.....	5-1
5-2 Troubleshooting On/Off Units.....	5-3
6-0 RETURN OF MATERIAL.....	6-1
6-1 Return Procedure.....	6-1
6-2 Repair Terms.....	6-1
7-0 REPLACEMENT PARTS.....	7-1
8-0 INDEX.....	8-1

LIST OF ILLUSTRATIONS

Figure 1-1.	Standard 2-1/2 Inch x 5 Inch Power Positioner (Variable Position Pilot Valve Type)	1-1
Figure 1-2.	On/Off 2-1/2 Inch x 5 Inch Power Positioner (On/Off Standard Option, Solenoid Valve Type)	1-2
Figure 2-1.	Installation Dimensions	2-2
Figure 2-2.	Mounting Pivot Base Assembly (Part No. 371763)	2-3
Figure 2-3.	Standard Unit Adjustment.....	2-4
Figure 2-4.	Limit Switch Option	2-6
Figure 3-1.	Standard Power Positioner - Main Components	3-2
Figure 3-2.	On/Off Power Positioner	3-4
Figure 4-1.	Pilot Valve Assembly — Exploded View.....	4-2
Figure 4-2.	Solenoid Valve Assembly — Exploded View.....	4-4
Figure 4-3.	Limit Switch Installation	4-8
Figure 5-1.	Standard Unit, Exploded View	5-4

LIST OF TABLES

Table 5-1.	Standard Unit Troubleshooting	5-2
Table 5-2.	On/Off Unit Troubleshooting	5-3
Table 7-1.	Recommended Spare Parts for the Standard Power Positioner	7-1
Table 7-2.	Recommended Spare Parts for the On/Off Power Positioner	7-1
Table 7-3.	Recommended Spare Parts for the Standard Pilot Valve Assembly.....	7-1
Table 7-4.	Bill of Materials for the 2-1/2 x 5 Power Positioner.....	7-2

PREFACE

The purpose of this manual is to provide information concerning the components, functions, installation and maintenance of the Hagan 2-1/2 x 5 Power Positioner.

Some sections may describe equipment not used in your configuration. The user should become thoroughly familiar with the operation of this module before operating it. Read this instruction manual completely.

DEFINITIONS

The following definitions apply to WARNINGS, CAUTIONS, and NOTES found throughout this publication.

WARNING

Highlights an operation or maintenance procedure, practice, condition, statement, etc. If not strictly observed, could result in injury, death, or long-term health hazards of personnel.

CAUTION

Highlights an operation or maintenance procedure, practice, condition, statement, etc. If not strictly observed, could result in damage to or destruction of equipment, or loss of effectiveness.

NOTE

Highlights an essential operating procedure, condition, or statement.

⊕ : EARTH (GROUND) TERMINAL

⊕ : PROTECTIVE CONDUCTOR TERMINAL

⚠ : RISK OF ELECTRICAL SHOCK

⚠ : WARNING: REFER TO INSTRUCTION BULLETIN

NOTE TO USERS

The number in the lower right corner of each illustration in this publication is a manual illustration number. It is not a part number, and is not related to the illustration in any technical manner.

IMPORTANT

**SAFETY INSTRUCTIONS
FOR THE WIRING AND INSTALLATION
OF THIS APPARATUS**

The following safety instructions apply specifically to all EU member states. They should be strictly adhered to in order to assure compliance with the Low Voltage Directive. Non-EU states should also comply with the following unless superseded by local or National Standards.

1. Adequate earth connections should be made to all earthing points, internal and external, where provided.
2. After installation or troubleshooting, all safety covers and safety grounds must be replaced. The integrity of all earth terminals must be maintained at all times.
3. Mains supply cords should comply with the requirements of IEC227 or IEC245.
4. All wiring shall be suitable for use in an ambient temperature of greater than 75°C.
5. All cable glands used should be of such internal dimensions as to provide adequate cable anchorage.
6. To ensure safe operation of this equipment, connection to the mains supply should only be made through a circuit breaker which will disconnect all circuits carrying conductors during a fault situation. The circuit breaker may also include a mechanically operated isolating switch. If not, then another means of disconnecting the equipment from the supply must be provided and clearly marked as such. Circuit breakers or switches must comply with a recognized standard such as IEC947. All wiring must conform with any local standards.
7. Where equipment or covers are marked with the symbol to the right, hazardous voltages are likely to be present beneath. These covers should only be removed when power is removed from the equipment — and then only by trained service personnel.
8. Where equipment or covers are marked with the symbol to the right, there is a danger from hot surfaces beneath. These covers should only be removed by trained service personnel when power is removed from the equipment. Certain surfaces may remain hot to the touch.
9. Where equipment or covers are marked with the symbol to the right, refer to the Operator Manual for instructions.
10. All graphical symbols used in this product are from one or more of the following standards: EN61010-1, IEC417, and ISO3864.

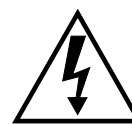

SECTION 1 DESCRIPTION

1-1 SCOPE

This manual gives information needed to install, operate, maintain and service all models of the Hagan 2-1/2 Inch x 5 Inch Thrust Type, Swivel Mounted Power Positioner.

1-2 PACKAGE CONTENTS

The power positioner comes completely assembled and carefully packaged to prevent damage in shipping. Inspect the packaging before removing the unit, and report any damage to the shipping agent.

Carefully pull the unit lengthwise out of the box. Find the packing list that is included in each shipment. Check the items received against the packing list to verify that the shipment is complete and correct. Make sure that the signal range stamped on the pilot valve is the one the packing list calls for. If a pivot base has been ordered, make sure it is attached to the unit. Check all items for damage.

1-3 EQUIPMENT DESCRIPTION

a. Purpose

The Hagan Power Positioner is typically used to position the damper of a large volume boiler. To do this, the power positioner connects to a lever on the damper jackshaft. The jackshaft connects to the damper. When the power positioner moves, the lever moves the jackshaft, which moves the damper.

b. Operation

There are two types of power positioners available: the standard variable position pilot valve type, and the on/off standard option with a solenoid valve. Both use the same power components. In both types, power air pressure moves a piston in a cylinder. When air flow goes to the top of the cylinder the piston moves upward.

When air flow goes to the top of the cylinder, the piston moves downward. As the piston travels, a clevis (attached to the piston rod) moves the damper lever.

The difference between the two positioner types is in the control power air system.

1. The Standard Power Positioner, Figure 1-1, uses a variable, low pressure control air circuit and a pilot valve assembly to control the single pressure power air. The higher the control air pressure, the farther the piston extends. With this type of equipment, boiler controls can move the power positioner to any point along its five inch stroke.

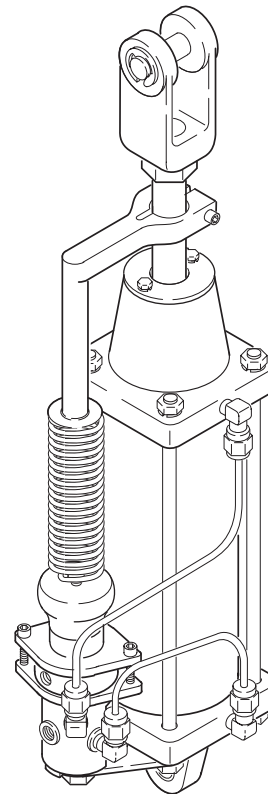

685001

Figure 1-1. Standard 2-1/2 Inch x 5 Inch Power Positioner (Variable Position Pilot Valve Type)

2. The On/Off Standard Option, Figure 1-2, uses electrical signals and a solenoid valve to control power air. The piston stops travel only at fully extended or fully retracted positions. The power positioner stays in position until the solenoid valve is electrically shifted. This makes the on/off type the best choice in applications where the damper must stay in position during an electrical power failure.

See Section 3, Theory of Operation, for detailed explanations of the operation of both power positioner models.

c. Limit Switch Option

Both the standard and on/off power positioners are available with limit switches. These limit switches signal the boiler control system when the power positioner is at the fully extended or fully retracted position. This option is available direct from the factory, or as a kit for field installation.

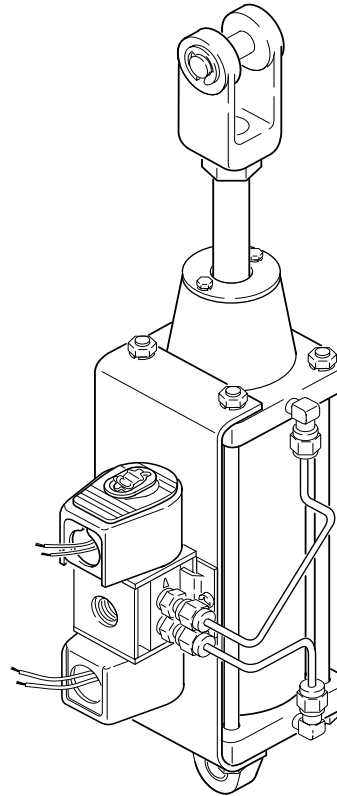

685002

Figure 1-2. On/Off 2-1/2 Inch x 5 Inch Power Positioner (On/Off Standard Option, Solenoid Valve Type)

SECTION 2 INSTALLATION AND ADJUSTMENTS

2-1 LOCATION

The positioner should be located in a clean, dry area free of excessive shock and vibration, with a continuous ambient temperature between 0° and 170°F (-18° and 77°C). It should be easily accessible for servicing.

2-2 MOUNTING

Before installation, carefully note the clearance dimensions and other mounting information shown in Figure 2-1. As shown in this figure, the positioner may be either clevis or pin mounted.

The positioner may be installed in any direction: vertical, horizontal, or inverted, whichever is most convenient. The mounting pivot base assembly (P/N 371763) is shown in Figure 2-2.

The power take-off clevis (Figure 2-1) should be properly aligned in relation to the axis of the mounting pivot. The center lines of the mounting pivot pin, linkage clevis pin, and linkage shaft must be parallel within two degrees.

Ensure that the arm anchoring the top of the large calibration spring is placed directly above the pilot valve, and that the spring is not twisted in such a way that will allow the pilot valve stem to rub on the sides of the casting.

2-3 AIR CONNECTIONS

a. Standard Units

Connect air to the pilot valve assembly. Control signal and power air connections, located in the pilot valve assembly, are

1/8 in. NPT taps. Refer to Figure 2-1. On the pilot valve the upper tap is for the input signal and the lower one is for the air supply. Copper tubing with 1/4 in. (6.35 mm) OD and 0.035 in. (0.89 mm) wall thickness is best. Note that the entire power positioner assembly moves when the piston extends. To keep this movement from stressing the copper air lines, coil each air line three turns near the unit.

A shutoff valve and air filter should be provided in the air supply line. The shutoff valve is necessary to isolate the positioner when servicing it. Recommended air supply pressure is 100 psi (689 kPa). Maximum air supply pressure is 125 psi (862 kPa). Minimum air supply pressure is 45 psi (310 kPa).

b. On/Off Units

Connect power air to the 0.25 in. NPT air tap on the valve body as shown in Figure 3-2. Copper tubing with a 1/4 in. OD and 0.035 in. wall thickness is best. Note that the entire power positioner assembly moves when the piston extends. To keep this movement from stressing the copper air line, coil three turns of the line near the unit.

A shutoff valve and air filter should be provided in the air supply line. The shutoff valve is necessary to isolate the positioner when servicing it. Recommended air supply pressure is 100 psi (689 kPa). Maximum air supply pressure is 125 psi (862 kPa).

Instruction Manual

IB-102-202N Rev. 1.2

January 2003

Hagan 2-1/2 x 5 Power Positioner

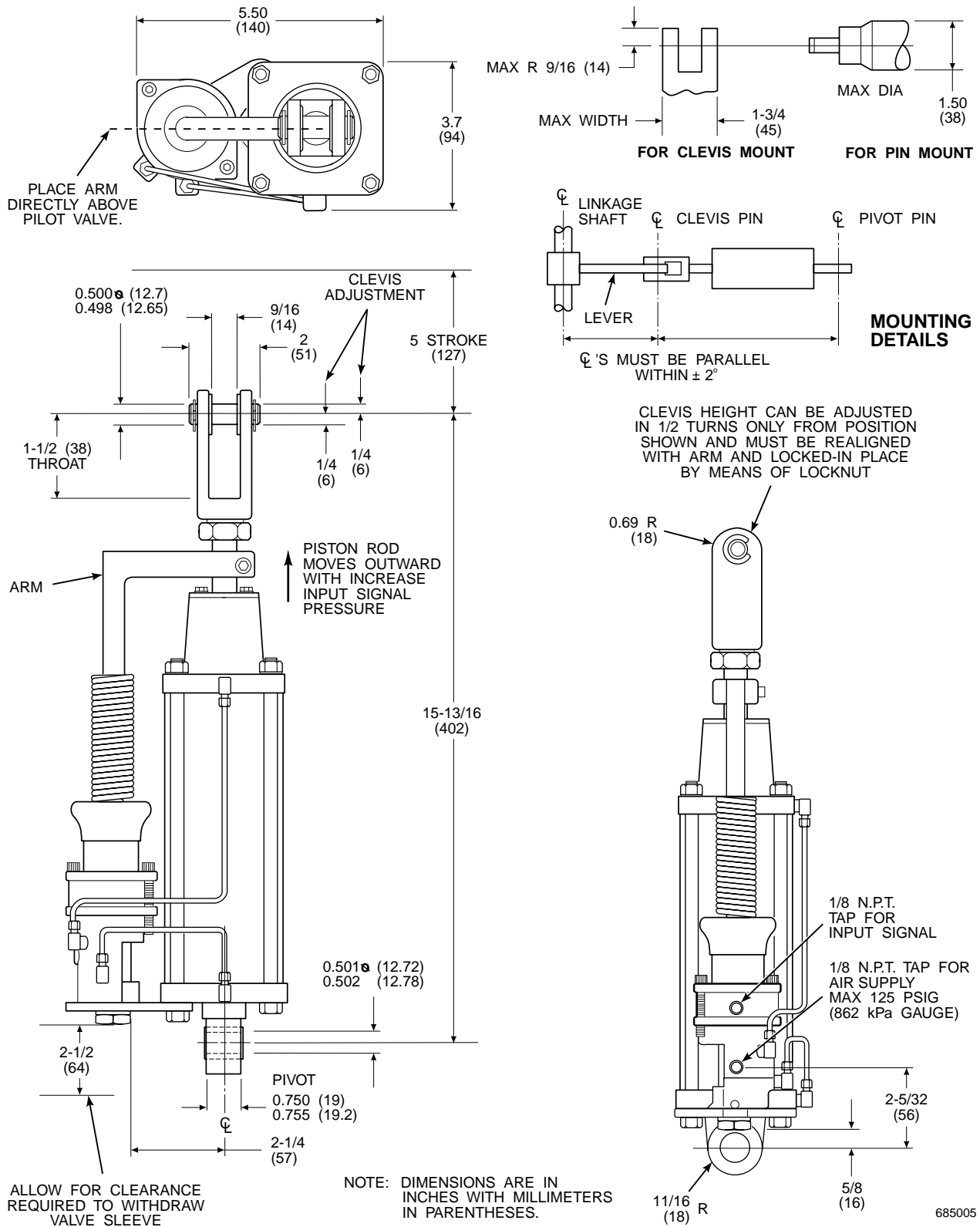

Figure 2-1. Installation Dimensions

Hagan 2-1/2 x 5 Power Positioner

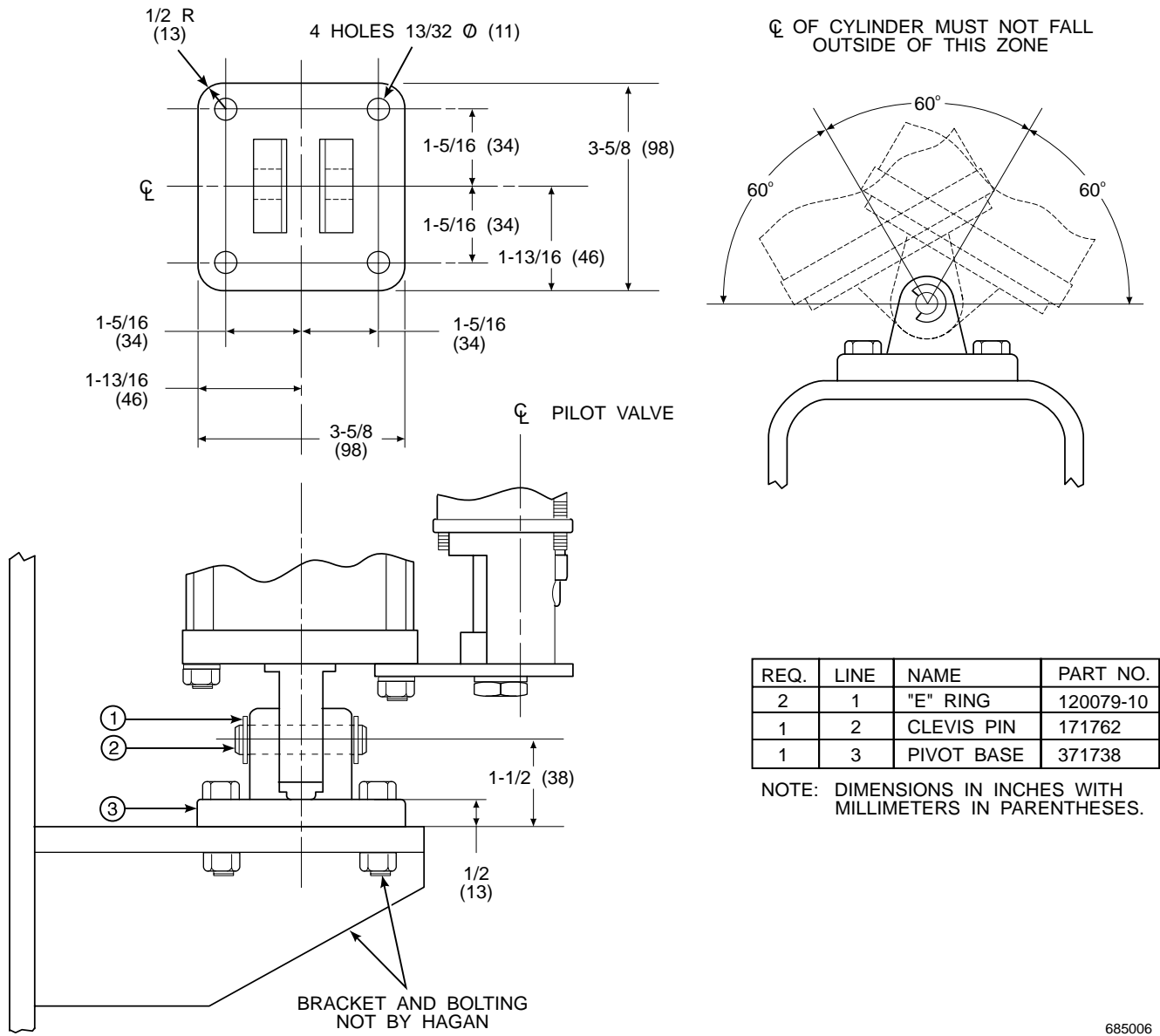

Figure 2-2. Mounting Pivot Base Assembly (Part No. 371763)

685006

2-4 WIRING

All wiring must comply with local and national electrical codes. Connections are designed for 0.50 in. conduit. Since the entire power positioner moves when the piston extends, use flexible conduit for all wiring. If the unit is likely to get wet, use liquid tight flexible conduit.

a. Standard Units

Wiring is not necessary on a standard unit with no limit switches.

WARNING

Be careful when removing the retaining clip to wire the solenoid valve. The retaining clip will spring upward when it disengages. This could cause injury.

CAUTION

Make sure that the solenoids and the electrical source are the same type. AC and DC solenoids are different internally and will be damaged by the wrong electrical current.

b. On/Off Units

Remove metal retaining clip (1, Figure 4-2) and rotate solenoid backplate (8) to the necessary position. Make the wiring connections necessary for the control system. Then replace the housing and nameplate and reinstall the retaining clip.

c. Limit Switches

To wire limit switches on either type of unit, remove the cover plate that is held by two screws, and wire the limit switches to the system controls as necessary.

2-5 ADJUSTMENT OF STANDARD UNITS

The standard power positioner must be adjusted so the piston is at the lower limit when the control signal is at minimum pressure, and moves to the upper limit when the signal is increased to maximum pressure. Refer to Figure 2-3 and use the following procedure to make the adjustment:

- a. Disconnect the mechanical linkage from the clevis.
- b. With the control (input) signal and power air supply lines disconnected from the pilot valve, clean the lines with high pressure air.

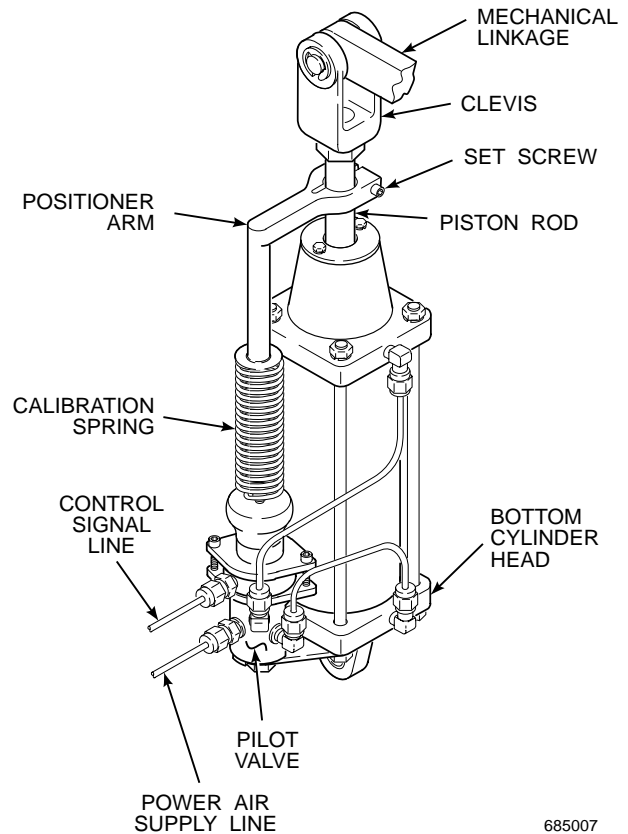

685007

Figure 2-3. Standard Unit Adjustment

Hagan 2-1/2 x 5 Power Positioner

- c. Open the air supply filter drain and blow out accumulated moisture and foreign particles.
- d. Reconnect the control signal and power air supply lines. Adjust power air supply pressure to desired value.

- e. Apply minimum control signal to the pilot valve. The piston should move to the lowest position, against bottom cylinder head. Check this in the following manner:

1. Maintain minimum control signal on the pilot valve.
2. Loosen the set screw on the positioner arm.
3. Move the positioner arm up until the piston moves to the bottom of the cylinder.
4. Move the positioner arm down until the piston begins to move upward.
5. Move the positioner arm down until the piston just returns to lowest position.
6. Lock this setting by tightening the set screw until the positioner arm binds to the piston rod.

- f. With the piston at the bottom of the cylinder, place a mark on either the clevis or the 1/2-in. diameter chrome plated piston rod. The mark is for use in measuring the piston stroke. If the stroke is not correct, increase or decrease the number of active coils in the calibration spring. Active coils are those which are free of the positioner arm and which flex when under load.

Determine stroke by increasing control signal pressure slowly and observing travel of the mark (discussed in preceding paragraph).

1. If the piston moves to upper limit before the control signal reaches maximum pressure, the number of active coils must be decreased as described in step g.

2. If piston travel is less than desired when maximum signal is applied, the number of active coils must be increased as described in step h. Maximum travel is approximately 5 in. (127 mm).
3. If piston stroke is satisfactory, perform steps i, j and k.

- g. To decrease the number of active coils, use the following procedure:

1. Reduce control signal to zero.
2. Count the active coils of calibration spring. Active coils are those which are free of the positioner arm and which flex when under load.
3. Determine the exact control signal pressure at which the piston reaches upper limit.
4. Determine the number of active coils required by using the following equation:

$$\frac{P_a}{P_m} \times C_a = \text{Number of active coils required}$$

Where:

P_a = Signal pressure at which piston reaches upper limit

P_m = Maximum control signal pressure to be used

C_a = Actual number of active coils

5. Reduce active coils to the number required by turning the calibration spring further onto the positioner arm.
6. Repeat step f to check the stroke again.

- h. To increase the number of active coils, use the following procedure:

1. Reduce control signal to zero.
2. Count active coils of calibration spring. Active coils are those which are free of

the positioner arm and which flex when under load.

3. Determine exact piston stroke by measuring amount of travel of the mark (on piston rod or clevis) when control signal is increased from zero to maximum pressure.
4. Determine the number of active coils required by using the following equation:

$$\frac{S_r}{S_a} \times C_a = \text{Number of active coils required}$$

Where:

S_a = Actual stroke
S_r = Required stroke
C_a = Actual number of active coils

5. Increase the number of active coils by turning spring off of the positioner arm.
 6. Repeat step f to see if desired stroke is obtained.
- i. Repeat step e to check minimum setting again.
 - j. Check mechanical linkage between the positioner and the damper or valve that the positioner positions. All links must be properly aligned.
 - k. Reconnect mechanical linkage to clevis.

2-6 ADJUSTMENT OF ON/OFF UNITS

There is no adjustments for on/off units.

2-7 ADJUSTMENT OF OPTIONAL LIMIT SWITCHES

Refer to Figure 2-4. Adjust the upper limit switch so the switch striker activates the switch when the piston reaches its fully extended limit. Adjust the lower limit switch so the striker activates the

switch when the piston reaches its fully retracted limit. Adjust the switches as follows:

- a. Observe the limit switches while running the power positioner. Each switch should activate just as the piston reaches its mechanical limit, and switch off as the piston begins to move in the other direction.
- b. To adjust a limit switch, loosen the switch mounting screws to allow the switch assembly to slide on its bracket. Slide switch assembly as necessary, then retighten the screws. Watch the switch again while running the positioner. Readjust as necessary.

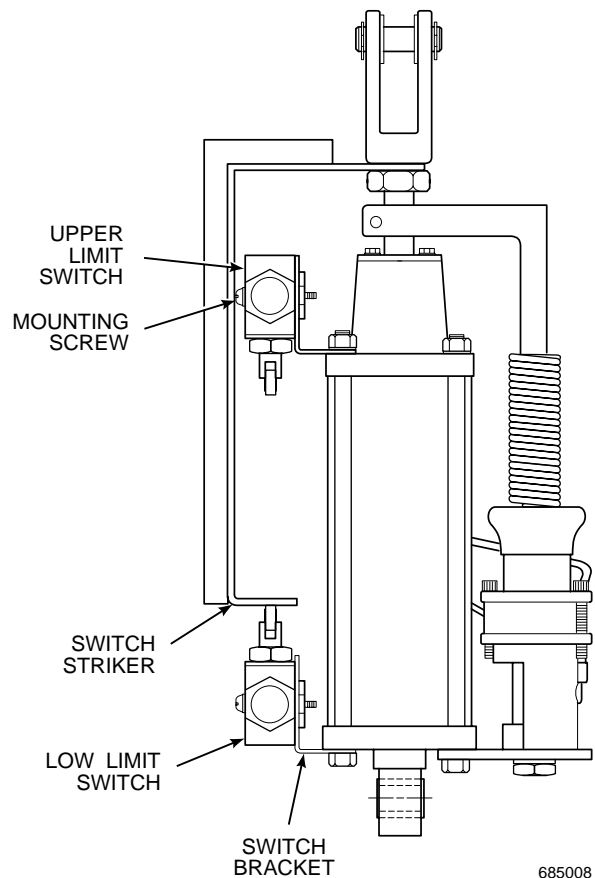

685008

Figure 2-4. Limit Switch Option

SECTION 3 THEORY OF OPERATION

3-1 STANDARD UNIT

a. General

Refer to Figure 3-1, Standard Power Positioner - Main Components. The piston assembly and power take-off clevis of the standard power positioner move away from the mounting pivot with an increase in control signal pressure. Movement of the piston, which is equipped with graphite impregnated teflon piston cups, begins when the increasing control signal at the pilot valve assembly causes the stainless steel stem to move downward from the neutral setting. The pilot valve assembly then directs power air through the bottom tubing assembly to the bottom of the aluminum cylinder and exhausts air at the other end of the cylinder to atmosphere. The resulting pressure difference across the piston moves it upward.

As the piston moves upward, it raises the upper end of the calibration spring. Tension in the spring is the feedback force in the pilot valve assembly. Piston movement continues until the spring force equals the force from the control signal, restoring the pilot valve stem to the neutral position. This blocks the flow of power air to cylinder and prevents further piston movement until signal pressure changes again.

For each control signal pressure, the piston is at a particular distance from the bottom of the cylinder. At the minimum signal it is at the lowest point in the cylinder. At the maximum signal it is at the upper limit, a distance of 5 in. (127 mm) from the lowest point. At any other signal, the distance from the bottom of the cylinder is proportional to the signal pressure. Full stroke time is two seconds or less. Toggling of the piston rod at or near full stroke is prevented by the large area guide bearings which are set

relatively far apart in the top head assembly. The guide bearings are made of sintered teflon.

b. Pilot Valve

The pilot valve is a force/balance device. The pilot valve makes use of an external calibration spring (connected to the positioner arm), an internal dual-diaphragm assembly, and a sleeve and stem assembly.

Pilot valve operation is determined by the interaction of two primary forces:

1. A downward force developed by the control signal as it acts upon the diaphragm assembly.
2. An upward force created by the tension of the calibration spring.

In operation, the pilot valve diaphragm assembly moves up or down and repositions the stem when the force of the calibration spring and the force due to the signal pressure are not in balance. Starting with the stem in the neutral position, an increase of the control signal pressure causes a downward movement of the pilot valve diaphragm assembly. This forces the stem downward, uncovering ports in a stainless sleeve which permit power air to flow into the lower end of the cylinder and the air in the upper end to exhaust to atmosphere. The piston moves upward, pulling on the calibration spring. Tension in this spring increases until it balances the force due to the control signal acting in the diaphragm assembly. The stem then returns to the neutral position and blocks the ports in the sleeve, preventing further movement of the piston.

Instruction Manual

IB-102-202N Rev. 1.2

January 2003

Hagan 2-1/2 x 5 Power Positioner

NOTE: AN ASTERISK (*) INDICATES ITEMS ARE INCLUDED IN THE PILOT VALVE ASSEMBLY.

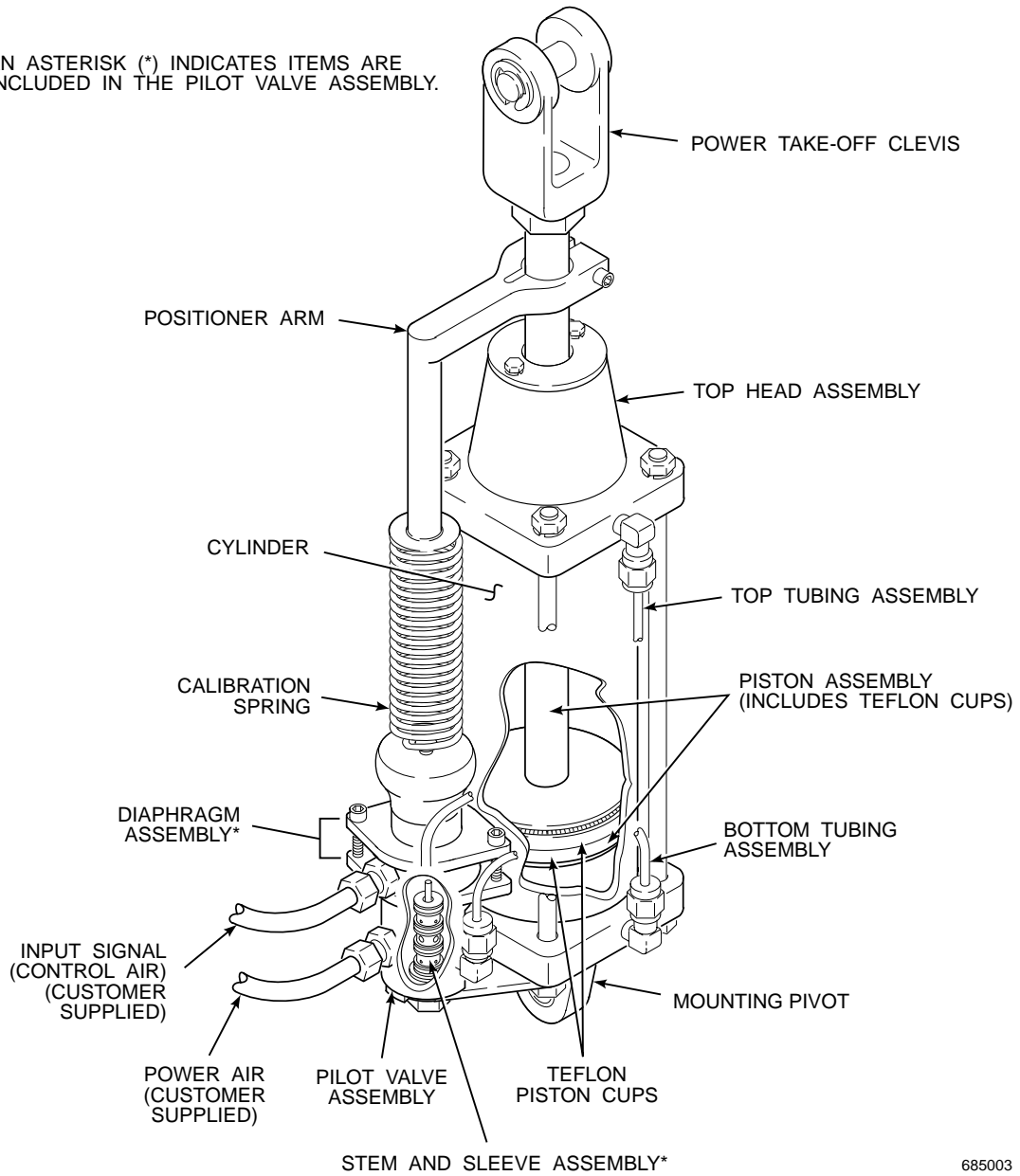

Figure 3-1. Standard Power Positioner - Main Components

685003

Hagan 2-1/2 x 5 Power Positioner

With a decrease in control signal pressure, the opposite actions occur. In this case, the force due to the control signal becomes less than the force of the calibration spring. The spring then pulls the spring post and stem seat upward. The stem is pushed upward by the spring in the pilot valve assembly and uncovers ports which transmit power air from the pilot valve to the top of the cylinder and exhaust the bottom of the cylinder. The piston then moves downward, reducing the tension in the calibration spring until it balances the force due to the lower control signal. The pilot valve assembly stem will then be in the neutral position again and prevent further movement of the piston.

3-2 ON/OFF STANDARD OPTION

a. General

On/off type power positioners, Figure 3-2, use the same cylinder and piston assembly as the standard type positioner. The on/off type, however, uses an electric solenoid assembly in place of a pneumatic pilot valve.

The solenoid assembly allows pressurized air to enter one end of the cylinder, while exhausting air from the opposite end to atmosphere. During operation, air pressure builds on one side of the piston, forcing the piston to move toward the low pressure side. Air from the low pressure side simultaneously exhausts through a fitting on the solenoid valve body.

b. On/Off Solenoid Valve

A solenoid operated, on/off valve controls air flow in the on/off standard option to the Rosemount power positioner. This system uses electrical impulses instead of pilot air pressure to control main air flow. There are only two positions for this type of equipment: piston fully out, and piston fully in. Once in a position, the piston stays in that position until the opposite solenoid is actuated. This means that if power fails, the piston stays in the same position. This feature makes the on/off type of valve the best choice in a system in which the damper must stay in place if power fails.

Instruction Manual

IB-102-202N Rev. 1.2

January 2003

Hagan 2-1/2 x 5 Power Positioner

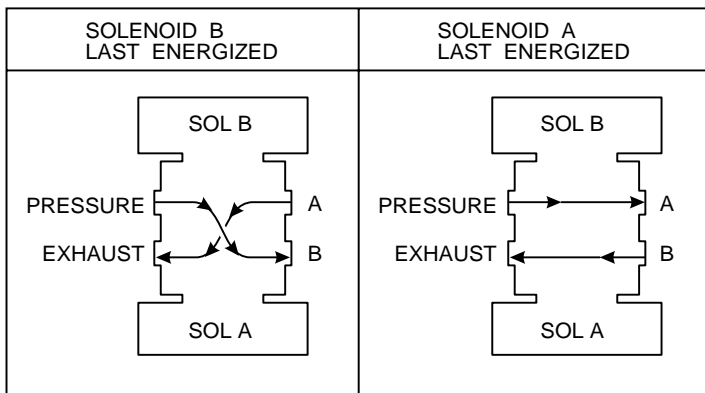

NOTE: IF SOLENOID B WAS LAST ENERGIZED, THE PISTON WILL BE FULLY EXTENDED. IF SOLENOID A WAS LAST ENERGIZED, THE PISTON WILL BE FULLY RETRACTED.

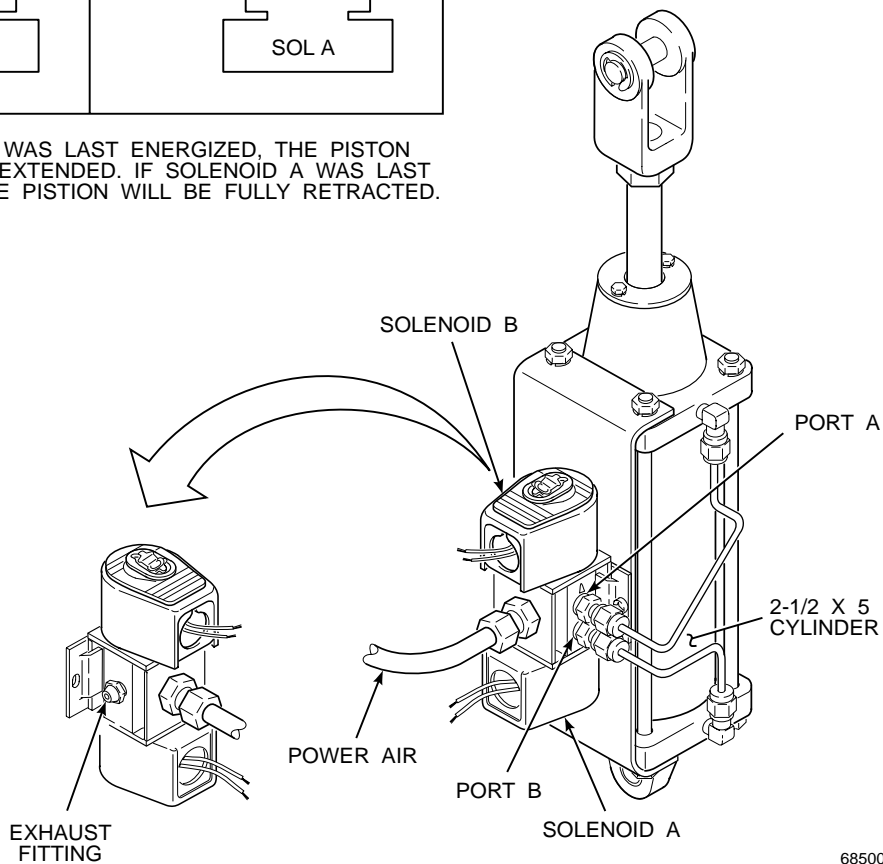

685004

Figure 3-2. On/Off Power Positioner

SECTION 4 MAINTENANCE AND SERVICE

4-1 SCHEDULED MAINTENANCE OF STANDARD UNITS

Design and construction of the standard power positioner greatly reduces routine maintenance. Only the following components need routine maintenance:

a. Air Supply

Drain the air line moisture trap daily. Clean or replace the air filter as necessary, depending on humidity, dust, and filter manufacturer's specifications.

b. Linkage Components

Lubricate clevis pin (2, Figure 5-1), customer-supplied mount pin, and linkage between the positioner and the component it controls every six months. Use a few drops of light oil.

c. Sleeve and Stem

For normal operating conditions in which a clean and dry supply of compressed air is used, the pilot valve sleeve and stem require inspection and cleaning every six months.

The same procedure is necessary if the stem is sticking. A sticking stem is indicated when the piston fails to move quickly to the required position during control signal changes. A worn stem must also be replaced. It is indicated by power air continuously blowing through the exhaust ports in the pilot valve body. Refer to Figure 4-1.

To clean and inspect the pilot valve, use the following procedure:

1. Shut off power air supply to pilot valve assembly.
2. Reduce control signal to zero.

NOTE

Many parts are small and may be easily lost or misplaced.

3. Unscrew sleeve retainer (18, Figure 4-1). Remove bottom loading spring (17) and bottom stem seat (16). Be careful not to lose stem, bottom stem seat and bottom loading spring.
4. Allow the stem to fall from pilot valve assembly on its own. Be careful that it does not fall on a hard surface. If stem will not fall out on its own, remove sleeve and stem as an assembly. The two can be separated on a bench without much danger of bending the stem.
5. Wash stem and sleeve with clean solvent. Do not use any abrasive or sharp edged tools. Dry sleeve with compressed air and wipe off stem with a clean lint free cloth.
6. Check stem for straightness by rolling it on a flat surface. If not perfectly straight, replace the stem and the sleeve.
7. Insert stem into bore of sleeve. (Since stem is symmetrical, it may be installed with either end up.)
8. Check stem in bore of sleeve. Stem must fall freely through sleeve by its own weight (when both stem and sleeve are dry, clean, and free of oil).

NOTE

Stem and sleeve must be replaced as a complete assembly if stem is bent or if either is worn.

9. Check that O-rings (13) on sleeve (14) are in good condition. Install new ones if necessary.

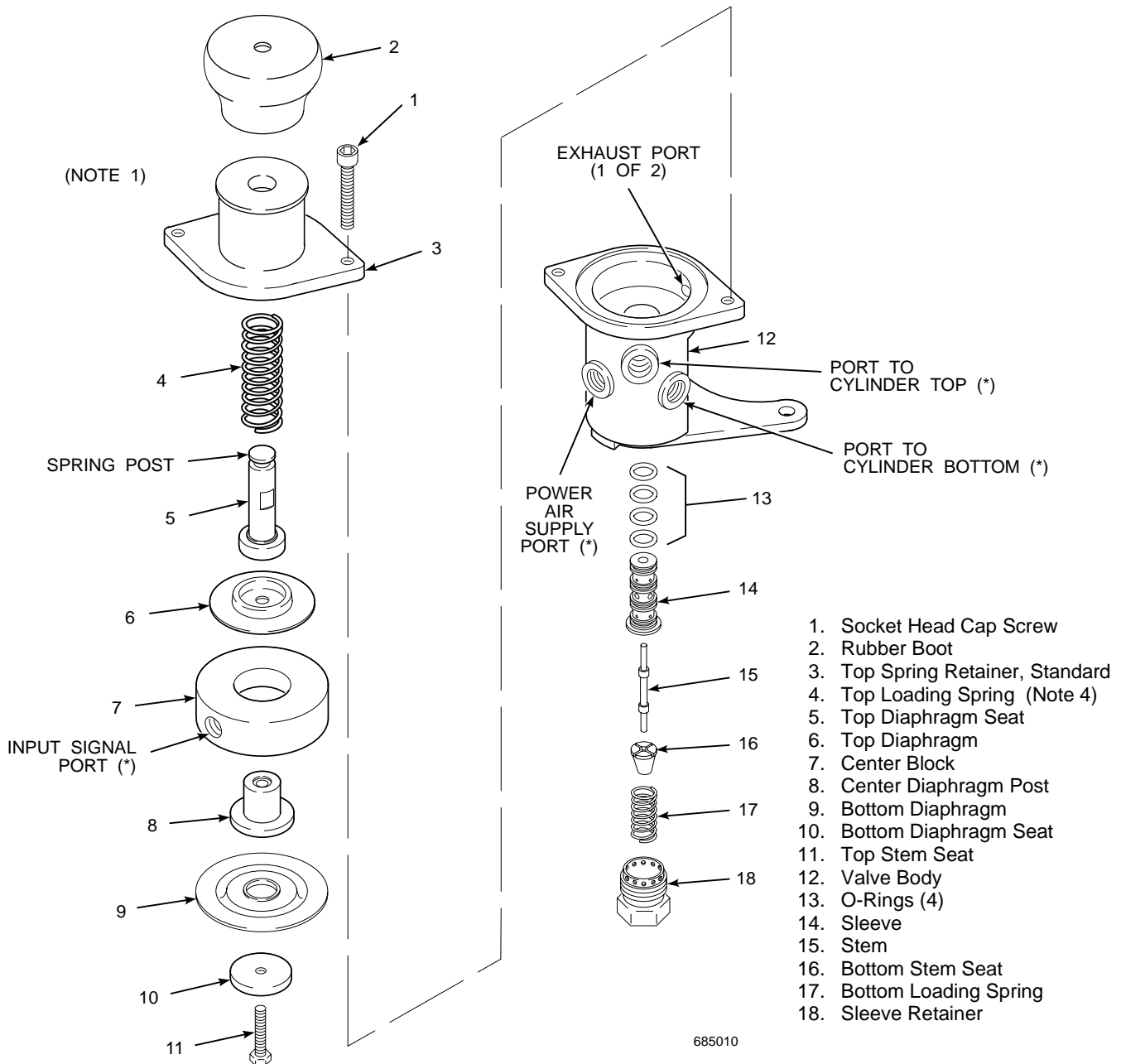

NOTE 1: 2-1/2 x 5 POWER POSITIONERS USING AN EPT REQUIRE A MODIFIED TOP SPRING RETAINER AND A TOP DIAPHRAGM COVER IN PLACE OF ITEM (3). IN THE STANDARD PILOT VALVE ASSEMBLY A TOP DIAPHRAGM COVER IS NOT USED.

NOTE 2: AN ASTERISK (*) INDICATES A 1/8 NPT TAPPED PORT.

NOTE 3: NOT ALL ITEMS IDENTIFIED ARE AVAILABLE FOR INDIVIDUAL SALE. SEE SECTION 7, REPLACEMENT PARTS, FOR A LIST OF AVAILABLE PARTS.

NOTE 4: ITEM 4 (TOP LOADING SPRING) IS USED FOR 0-30 PSI SIGNAL ONLY.

Figure 4-1. Pilot Valve Assembly — Exploded View

Hagan 2-1/2 x 5 Power Positioner

10. Install sleeve in pilot valve assembly.
11. Insert stem in sleeve and replace pilot valve bottom stem seat (16), bottom loading spring (17), and sleeve retainer (18). Turn sleeve retainer in until it hits bottom of sleeve and holds it firmly in place.
12. Turn on air supply pressure and reapply control signal. Power positioner is then ready for operation.

4-2 SCHEDULED MAINTENANCE OF ON/OFF UNITS

The on/off type power positioner requires very little maintenance. Only the following three components need scheduled maintenance:

a. Air Supply

Drain air line moisture trap daily. Clean or replace the air filter as necessary, depending on humidity, dust, and filter manufacturer's specifications.

b. Linkage Components

Lubricate clevis pin (2, Figure 5-1), mount pin and linkage between the positioner and the component it controls every six months. Use a few drops of light oil.

c. Solenoid Valve

If the air supply is clean and dry, inspect and clean solenoid valve (18, Figure 4-2) every six months, or if leaky, noisy or sluggish. To do this, follow this procedure:

1. Depressurize valve (18) and turn off electrical supply. Disconnect piping if that makes access to the valve easier.

WARNING

Be careful when removing retaining clip. It is spring loaded and will spring upward when released. This could injure personnel.

2. Prevent retaining clip (1) from springing away. Remove the retaining clip from each side of the valve. Then remove each entire assembled solenoid enclosure (items 3 through 8) from the solenoid base subassembly.

3. Disassemble each solenoid by removing bonnet screws (22), bonnet plates (9 and 23), solenoid base subassembly (11), and body gasket (17).
4. Slide core subassembly (12) toward cylinder port B side of valve body. Remove detent (19) and detent washer (20) from core subassembly. Remove core subassembly through cylinder port A side of valve body.
5. Remove discs (13), sleeve (14), and quad ring gasket (15) from core subassembly.
6. Inspect all parts. Replace solenoid valve assembly if worn or damaged.
7. Clean metallic parts with solvent and a stiff non-metallic brush. Do not scratch parts or remove any material.
8. Reinstall discs (13), sleeve (14), and quad ring gasket (15) in core subassembly (12).
9. Lubricate inside walls of valve body and solenoid base subassemblies with high grade silicone grease. Carefully observing notes on Figure 4-2, slide core subassembly into cylinder port A side of valve body.
10. Push core subassembly far enough toward cylinder port B side to install detent (19) and detent washer (20). Then install each body gasket (17), solenoid base subassembly (11), upper bonnet plate (9), lower bonnet plate (23) and bonnet screws (22).
11. Reinstall both assembled solenoid enclosures (items 3 through 8). Put on nameplates (2) and secure each assembly with a retaining ring (1).
12. Operate the valve a few times to make sure it is working properly before returning power positioner to service.

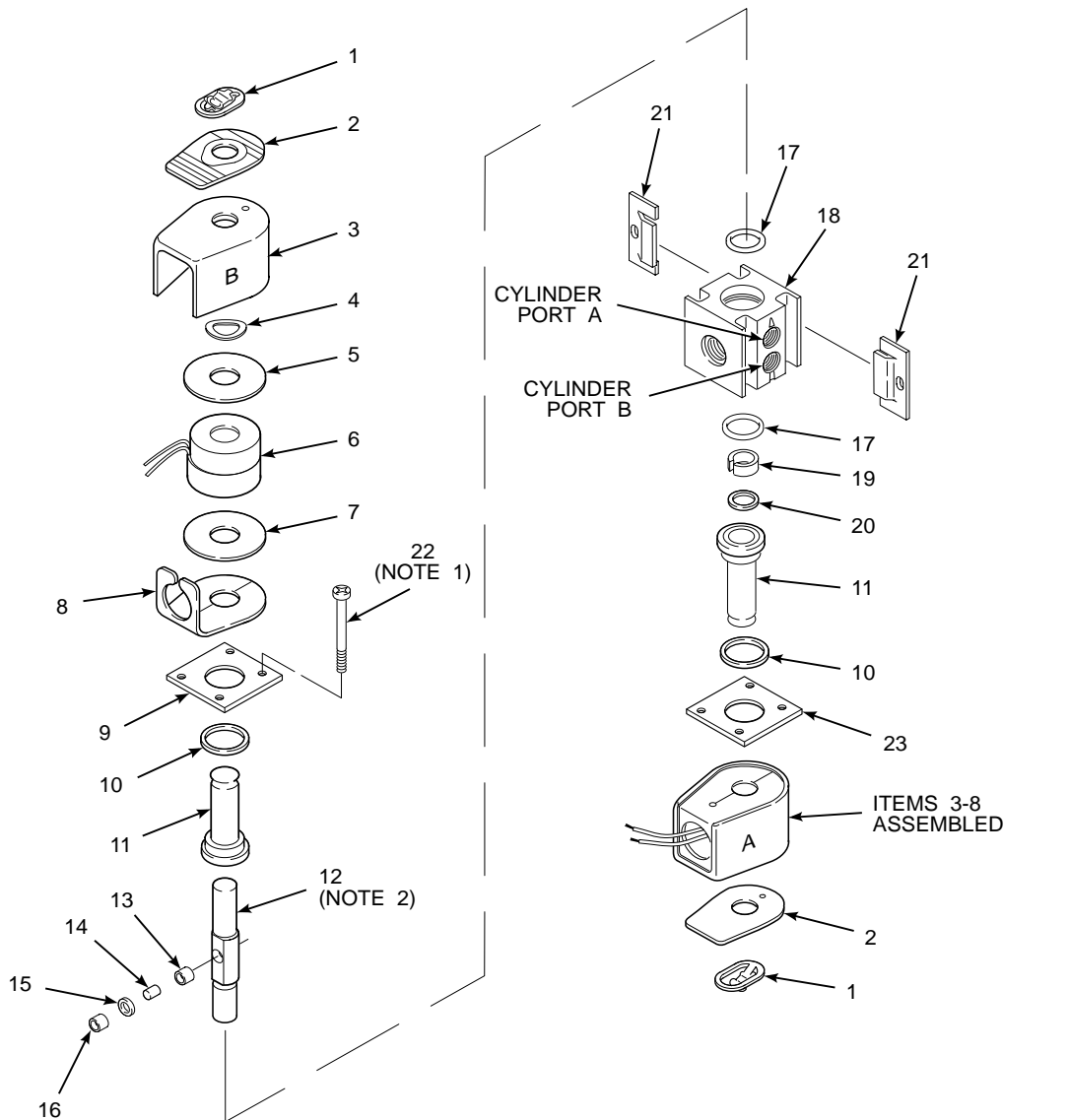

NOTE 1: TORQUE TO 20 TO 25 IN-LBS (2 TO 3 N•M).

NOTE 2: GROOVED END OF ITEM (12) MUST FACE SOLENOID "A" WITH DETENT. ITEM (12) MUST BE INSERTED FROM PORT A-SIDE OF ITEM (18). THE PASSAGEWAY IN ITEM (12) MUST BE ORIENTED WITH THE PORTS OF ITEM (18).

685011

- | | | |
|---|-------------------------------|------------------------|
| 1. Retaining Clip | 9. Upper Bonnet Plate | 17. Body Gasket |
| 2. Nameplate | 10. Washer | 18. Valve Body |
| 3. Housing | 11. Solenoid Base Subassembly | 19. Detent |
| 4. Spring Washer | 12. Core Subassembly | 20. Detent Washer |
| 5. Insulating Washer (Not on all units) | 13. Disc | 21. Mounting Bracket |
| 6. Coil | 14. Sleeve | 22. Bonnet Screw |
| 7. Insulating Washer (Not on all units) | 15. Quad Ring Gasket | 23. Lower Bonnet Plate |
| 8. Baseplate | 16. Disc | |

Figure 4-2. Solenoid Valve Assembly — Exploded View

Hagan 2-1/2 x 5 Power Positioner

4-3 REPAIRS TO CONTROL SYSTEM

a. Replacement of Pilot Valve Diaphragms

Refer to Figure 4-1. Diaphragms (6 and 9) in the pilot valve assembly must be replaced if they are soft and spongy, hard and brittle, or broken. A broken diaphragm shows up as erratic operation of the power positioner with the piston not moving to the upper limit when the maximum signal is applied to the pilot valve. If the break is large, considerable signal air will be noticed continuously leaking from the pilot valve assembly.

Use the following procedure when inspecting and replacing diaphragms.

1. Shut off air supply.
2. Reduce control (input) signal to positioner to zero and disconnect input signal line at pilot valve assembly.
3. Disconnect calibration spring from top diaphragm seat spring post (5, Figure 4-1).
4. Remove socket head cap screws (1). Remove items (2) through (11) as an assembled unit.

NOTE

Top stem seat (11) unthreads from top diaphragm seat (5), allowing both diaphragms (6 and 9) to be removed.

5. Remove top stem seat (11).

CAUTION

Excessive clamping pressure produced by exceeding torque valve will damage diaphragms. Do not exceed specified torque valves.

6. Replace diaphragms if broken, hard and brittle, or soft and spongy. Reassemble diaphragm assembly with Loctite™ sealant on threads of top stem seat (11). Torque assembly to 1 to 1-1/2 ft-lbs (1 to 2 N·m).

7. Reassemble items (1) through (11) to valve body (12). Only tighten screws (1) by hand at this time.
8. Apply and maintain 10 psi (69 kPa) air pressure between diaphragms through signal input port.
9. Turn screws (1) alternately and in steps to a torque of 2 ft-lbs (3 N·m).
10. Remove input signal air pressure.
11. Turn screws (1) alternately and in steps to a torque of 4 ft-lbs (5 N·m).
12. Connect the calibration spring to spring post.
13. Remove the 10 psi (69 kPa) line and reconnect the control signal line to pilot valve assembly. Turn on air supply pressure. Power positioner is then ready for operation.

b. Repairs To On/Off Control System

There are no repairs authorized on the on/off control system other than cleaning the solenoid valve (paragraph 4-2c).

4-4 REPAIRS TO CYLINDER ASSEMBLY (Standard and On/Off)

a. Replacement of Piston Rod Seal

Refer to Figure 5-1. Excessive air leakage from the top head assembly (15, Figure 5-1) past the piston rod (5) indicates that the silicone seal (12) is worn and must be replaced. The instructions below apply to both standard and on/off type units. Where there is a difference between the units, be sure to follow instructions for the specific unit used. To replace piston rod seal proceed as follows:

1. Move piston to bottom of cylinder by either reducing control signal to zero (standard units) or actuating solenoid A. Then shut off air supply.
2. Disconnect linkage at clevis (3, Figure 5-1).
3. On standard units only, mark the location of positioner arm (6) on piston rod

- (5). Disconnect lower end of calibration spring (8) from pilot valve spring post.
4. On standard units, loosen clamping screw (7) in arm (6).
 5. Hold clevis and loosen locknut (4) with a wrench. Unscrew clevis and locknut, and remove the arm from the piston rod.
 6. Unscrew cap screws (9), and remove lockwasher (17), and seal retainer (11) to expose seal (12).
 7. In order to ease removal of seal, place one layer of plastic electrical-type tape over piston rod threads. Start tape at outer end of piston rod and overlap it with raised edges facing the same direction the seal is to be removed. The tape should also be lubricated with a coating of McLube™ MOS₂-200 grease.
 8. Slip seal off piston rod.
 9. Before installing new seal, remove tape installed in step 7. Retape threads in opposite direction. Tape should be overlapped, with raised, sharp edges facing downward so that they will not scratch seal as it is pulled down piston rod. Tape should also be lubricated with a light coating of McLube™ MOS₂-200 grease.
 10. Install a new seal after lubricating it with McLube™ MOS₂-200 grease.
 11. Reassemble power positioner, using preceding steps in reverse order. Clevis and arm must be properly aligned and located. Use the mark made in step 3 when reassembling arm (6) on standard units.
 12. After reassembling unit, perform steps in paragraph 2-5, Adjustment of Standard Units. The positioner will then be ready for operation.

b. Replacement of Piston Cups

If the piston moves in a jerky manner, it is usually an indication of an accumulation of sticky material on the inside walls of the cylinder (19, Figure 5-1). For the positioner to operate properly, the cylinder walls must be clean.

If graphite impregnated teflon piston cups (22) wear to the extent that air leaks past the piston, they should be replaced. This is indicated by power air blowing continuously through the exhaust openings of the pilot valve.

Before cleaning the cylinder walls or replacing the piston cups, make sure there is no problem in the control system. Both standard and on/off units can operate like there is a piston cup problem when their control system is dirty. Before replacing piston cups, follow cleaning procedures in paragraph 4-1c or 4-2c. If this does not solve the problem, proceed as follows:

NOTE

Unless otherwise indicated, item numbers refer to Figure 5-1.

1. Shut off all air supply. Disconnect electrical power to on/off units.
2. Disconnect power and control air supply lines to pilot valve assembly (27, Figure 5-1) or solenoid valve assembly (Figure 4-2). Disconnect mechanical linkage at clevis (3, Figure 5-1).
3. Remove pivot pin through bottom cylinder head (26) and place positioner on a work bench.
4. On standard units, disconnect calibration spring (8) from pilot valve.
5. Disconnect tubing connections from bottom cylinder head (26).
6. Remove hex nuts (13), lockwashers (14), and four steel tie-rods (28).

7. For on/off units, remove bottom cylinder head (26).
8. On standard units, remove pilot valve assembly (27) and bottom cylinder head (26).
9. Invert the remaining positioner assembly and support it vertically by clamping clevis (3) in a vise.
10. Remove cylinder (19) from piston assembly by slowly turning the cylinder clockwise while pulling it upward, away from top head assembly (15).
11. Clean out bore of cylinder with a cloth soaked in a solvent. Do not scrape with sharp tools or use abrasive materials such as emery cloth.
12. Inspect piston cups (22). If worn, creased, or scratched, they must both be replaced.
13. If piston cups require replacement, remove locknut (25) and washer (24) from rod (5). Two piston cup followers (21) and piston cups may then be slipped off the end of the piston rod.

CAUTION

Be careful that piston cups are not creased or scratched during assembly. Damaged piston cups will impair positioner performance.

14. Reassemble piston assembly and insert it into cylinder in the following manner:
 - (a) Assemble parts of piston on end of piston rod, except outer garter spring (20) and outer piston cup.
 - (b) Turn locknut (25) until only finger tight.
 - (c) Check that gasket (17) is in place at top head assembly and then slip cylinder down over the piston assembly until washer (24) is about 1/4 in. (6 mm) from end of cylinder.
 - (d) Remove locknut (25), washer (24), and outer piston cup follower (21).

Install outer piston cup (22), outer piston cup follower (21) and garter spring (20); reassemble entire piston. Tighten locknut (25).

- (e) Hold top head assembly and pull cylinder back over piston assembly until piston is approximately half way into cylinder.
15. Remove positioner from vise. Pull top head assembly along piston rod until it hits the end of the cylinder. Reassemble positioner by installing control system assembly and bottom cylinder head at lower end of cylinder and installing studs, lockwashers and nuts.
16. Connect tubing assemblies to bottom cylinder head.
17. On standard units, connect calibration spring to pilot valve assembly.
18. Mount positioner and connect linkage to clevis. Connect power air supply and either control air signal lines or electrical lines to control system. Open control signal air or close electrical power switch.
19. Turn on power air supply pressure. The positioner is now ready for operation.

4-5 INSTALLATION OF LIMIT SWITCHES

The following instructions cover the installation of a limit switch kit onto either a standard or on/off type power positioner.

- a. Check parts kit items against those of Figure 4-3.

WARNING

Shut off all air pressure and electricity to power positioner, and remove and block mechanical load before beginning this procedure. Failure to do this could allow the power positioner to move. This could injure personnel or damage equipment.

- b. Orient power positioner as shown in Figure 4-3. Clevis must be up, and pilot valve or solenoid valve to the right.

- c. Assemble limit switches (1, Figure 4-3) and brackets (3), using nut plate (7), flat washers (5), lockwashers (6) and screws (4). Orient limit switches as shown. Slide limit switches to outermost point in slots. This is to prevent damage from switch striker (2) before adjustment.
- d. Remove two tie-rods (A) from left side of cylinder.
- e. Install bottom bracket (3) on tie-rods (A) and insert tie-rods through cylinder heads. Install top bracket, lockwashers (D) and nuts (E) on top of tie-rods (A) and torque to 8 to 12 ft-lbs (11 to 16 N·m).
- f. Loosen nut (B) under clevis (C); remove clevis. Install switch striker (2); reinstall clevis. Retighten nut under clevis, making sure switch striker lines up with switch actuator rollers.
- g. Connect wiring to limit switches as the boiler controls require. Remove cover to get to terminal screws. Because the entire power positioner moves while in service, use Greenfield™ flexible conduit. If the unit is likely to get wet, use liquid-tight flexible conduit.
- h. Adjust limit switches so that they switch as the piston reaches the fully extended and fully retracted positions.

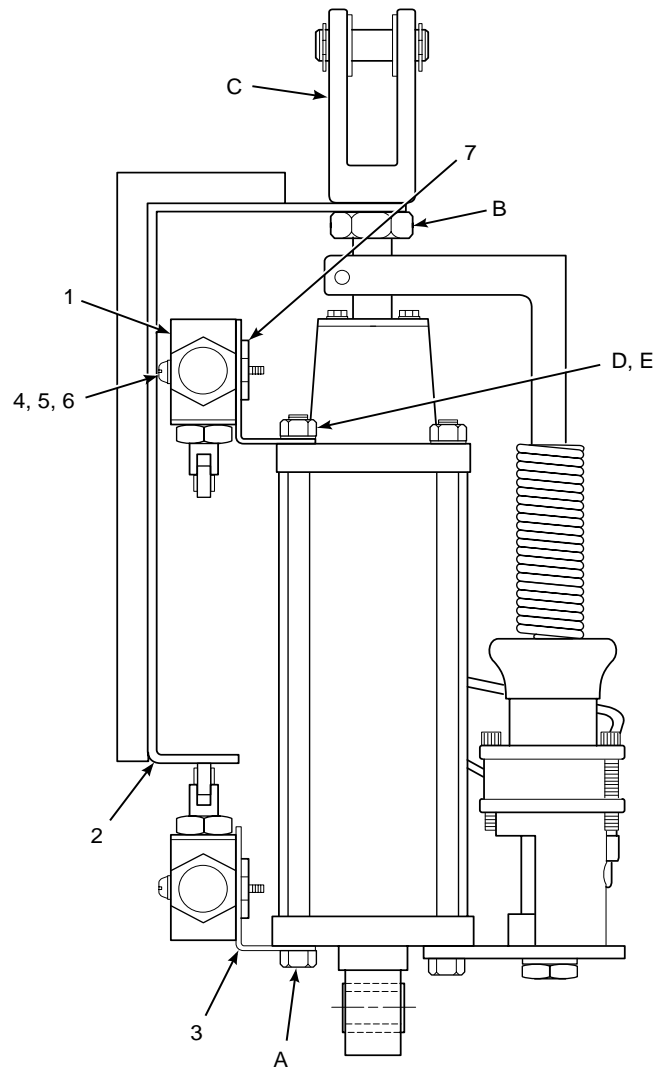

NOTE: LETTER DESIGNATIONS REFER TO NON-KIT ITEMS MENTIONED IN INSTALLATION TEXT, PARAGRAPH 5-5.

685012

1. Observe limit switches while running power positioner to both limits. Each switch should switch on just as the piston reaches its mechanical limit, and switch off as the piston begins to go in the other direction.
2. To adjust switch, loosen screws (4, Figure 4-3) until switch assembly will slide. Slide switch assembly as necessary, then retighten screws. Watch switch again while running piston. Re-adjust as necessary.

LIMIT SWITCH KIT ITEMS		
ITEM	DESCRIPTION	QTY
1	LIMIT SWITCH	2
2	SWITCH STRIKER	1
3	SWITCH BRACKET	2
4	PAN HEAD SCREW	4
5	FLAT WASHER	4
6	LOCKWASHER	4
7	NUT PLAT	2

Figure 4-3. Limit Switch Installation

SECTION 5 TROUBLESHOOTING

5-1 TROUBLESHOOTING STANDARD UNITS

The four most common causes of poor operation of the standard power positioner are listed below. Check if any of these conditions exist and make corrections, if necessary, before starting any repairs. If none of these conditions apply, Refer to Table 5-1, Standard Unit Troubleshooting.

- a.** Air supply pressure is below normal. Check for the following conditions:
 1. Complete loss of air supply or less than normal air supply pressure.
 2. Air supply to the positioner shut off at a valve or cut off due to a change or break in the piping.
 3. Pressure reducing valves in the system incorrectly adjusted.
 4. Air filters restricting flow due to dirty elements. Blow down all filters.
- b.** Plugged signal or air supply line. Check that all lines are clean. Clear out any foreign material which may be blocking them.
- c.** Leaks in signal lines, air supply lines and tubing assemblies. Go over each joint and connection in these lines with soap suds to check for air leaks. Stop any leaks found.
- d.** Excessive friction at mounting pivot, clevis and associated mechanical linkage. Check that these points are well oiled, not binding, or otherwise inhibited.

Table 5-1. Standard Unit Troubleshooting

NOTE

Unless otherwise indicated, item numbers are in reference to Figure 5-1.

Symptom	Cause	Solution
<p>1. Erratic operation along with one of the following:</p> <ul style="list-style-type: none"> a. Piston moves in a jerky manner. b. Piston fails to move to desired position quickly when signal changes. c. Power air [100 psi (689 kPa)] continuously blowing through exhaust ports of pilot valve assembly. 	<ul style="list-style-type: none"> a. Sticky material on inside of cylinder wall. b. Stem (15, Figure 4-1) sticking due to gummy deposits. c. Stem (15, Figure 4-1) excessively worn. 	<ul style="list-style-type: none"> a. Clean cylinder walls. b. Clean stem and sleeve. c. Replace stem and sleeve.
<p>2. Piston does not move full stroke when maximum signal is applied and one of the following symptoms is present:</p> <ul style="list-style-type: none"> a. No other symptoms. b. Signal air [15, 30, or 60 psi (103, 207, or 414 kPa)] continuously leaking from exhaust ports of pilot valve assembly (27). c. Power air [100 psi (689 kPa)] blowing continuously through exhaust ports of pilot valve assembly (27). 	<ul style="list-style-type: none"> a. Too few active coils in calibration spring (8). b. Broken diaphragm in pilot valve assembly. c. Piston cups (22) worn. 	<ul style="list-style-type: none"> a. Increase number of active coils in spring (8). Refer to paragraph 2-5h. b. Replace broken diaphragm. c. Replace both piston cups.
<p>3. Piston does not return to bottom of cylinder when signal is zero and one of the following symptoms is present:</p> <ul style="list-style-type: none"> a. No other symptoms. b. Power air leaking past piston rod (5) at seal retainer (11). c. Power air continuously blowing out of exhaust ports of pilot valve assembly (27). 	<ul style="list-style-type: none"> a. Positioner requires adjustment. b. Piston rod seal (12) worn. c. Piston cups (22) worn. 	<ul style="list-style-type: none"> a. Perform Adjustments of Standard Units, paragraph 2-5. b. Replace piston rod seal. c. Replace both piston cups.

Hagan 2-1/2 x 5 Power Positioner

5-2 TROUBLESHOOTING ON/OFF UNITS

Refer to Table 5-2, On/Off Unit Troubleshooting, for a listing of possible symptoms, causes and

solutions for problems with an on/off type power positioner. Cylinder and piston assembly parts are identical to those of the standard unit (Figure 5-1).

Table 5-2. On/Off Unit Troubleshooting

NOTE

Unless otherwise indicated, item numbers are in reference to Figure 4-2.

Symptom	Cause	Solution
1. Erratic operation along with one of the following: a. Piston moves in a jerky manner. b. Piston fails to move to desired position quickly when signal changes. c. Power air [100 psi (689 kPa)] continuously blowing through exhaust ports of pilot valve assembly.	a. Sticky material on inside of cylinder wall. b. Core subassembly (12) sticking due to gummy deposits. c. Valve (18) or piston cups (22, Figure 5-1) excessively worn.	a. Clean cylinder walls. b. Clean core subassembly. c. Replace worn components.
2. Piston does not move full stroke when maximum signal is applied and one of the following symptoms is present: a. No other symptoms. b. Excessive leakage at solenoid valve.	a. Open or burned out coil (6) in solenoid. Faulty control circuit. b. Worn or damaged parts in solenoid valve assembly.	a. Check continuity of coil. Replace if necessary. Energize solenoid; listen for metallic click. No click means no voltage. b. Replace solenoid valve assembly.
3. Piston does not return to bottom of cylinder when opposite solenoid is energized.	a. Open or burned out coil (6) in solenoid. Faulty control circuit.	a. Check continuity of coil. Replace if necessary. Energize solenoid; listen for metallic click. No click means no voltage.

NOTE

Replacement parts for the solenoid valve assembly are available from ASCO Valves at the following address:

**ASCO Valves
Automatic Switch Co.
Florham Park, NJ 07932**

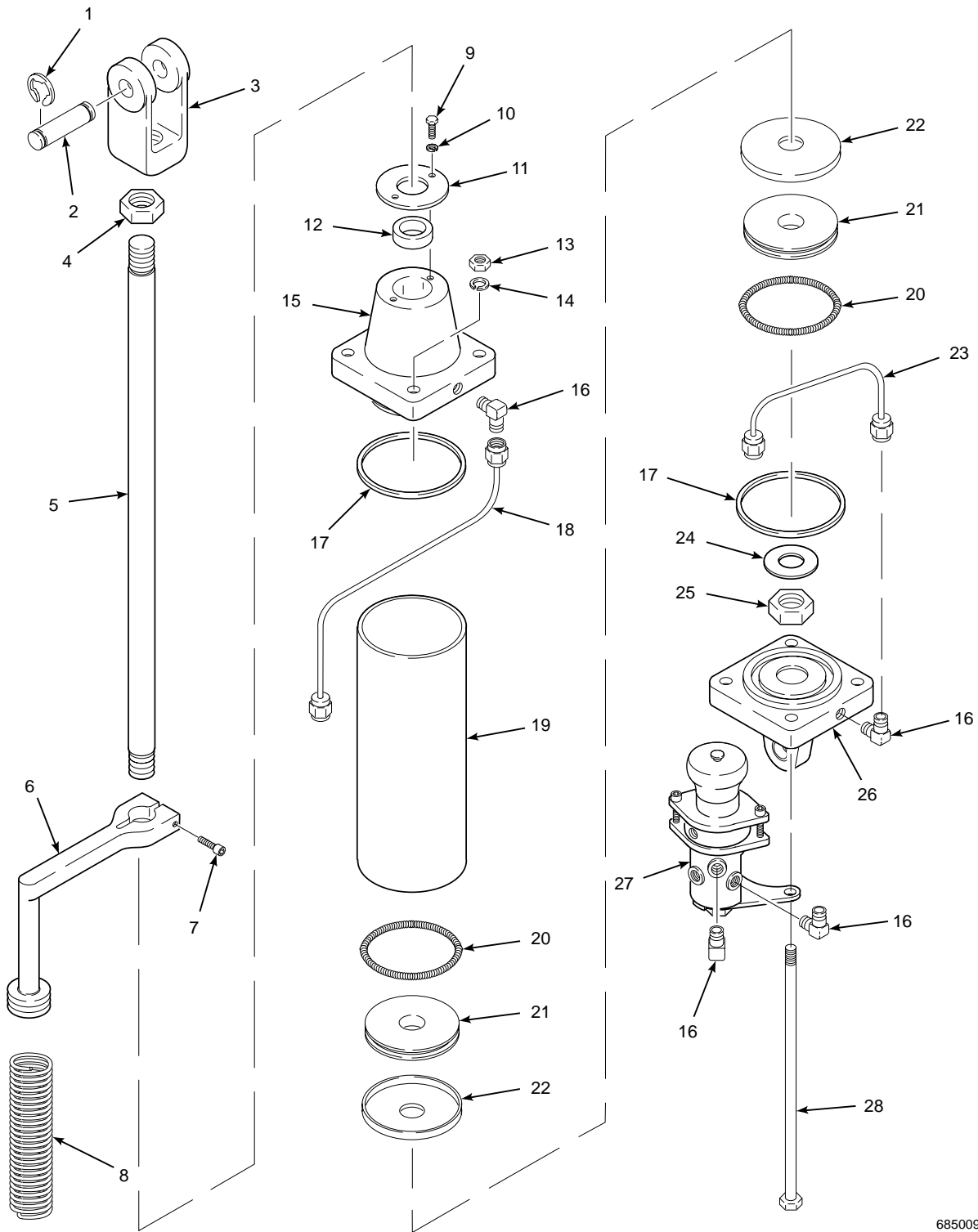

685009

Figure 5-1. Standard Unit, Exploded View

LEGEND FOR FIGURE 5-1

- | | |
|--------------------------|--------------------------|
| 1. Retaining Ring | 15. Top Head Assembly |
| 2. Clevis Pin | 16. Elbow Fitting |
| 3. Clevis | 17. Cylinder Head Gasket |
| 4. Hex Nut | 18. Top Tubing |
| 5. Piston Rod | 19. Cylinder |
| 6. Positioner Arm | 20. Gaster Spring |
| 7. Socket Head Cap Screw | 21. Piston Cup Follower |
| 8. Calibration Spring | 22. Piston Cup |
| 9. Cap Screw | 23. Bottom Tubing |
| 10. Lock Washer | 24. Washer |
| 11. Seal Retainer | 25. Elastic Stop Nut |
| 12. Seal | 26. Bottom Cylinder Head |
| 13. Hex Nut | 27. Pilot Valve Assembly |
| 14. Lock Washer | 28. Tie-Rod |

Instruction Manual

IB-102-202N Rev. 1.2

January 2003

Hagan 2-1/2 x 5 Power Positioner

SECTION 6 RETURN OF MATERIAL

6-1 RETURN PROCEDURE

If factory repair of defective equipment is required, proceed as follows.

- a. Secure a return authorization from a Rosemount Analytical Sales Office or Representative before returning the equipment. Equipment must be returned with complete identification in accordance with Rosemount instructions or it will not be accepted.

In no event will Rosemount be responsible for equipment returned without proper authorization and identification.

- b. Carefully pack defective unit in a sturdy box with sufficient shock absorbing material to insure that no additional damage will occur during shipment.
- c. In a cover letter, describe completely:
 1. The symptoms which indicate that the equipment is faulty.
 2. The environment in which the equipment has been operating (housing, weather, vibration, dust, etc.).
 3. Site from which equipment was removed.

4. Whether warranty or nonwarranty service is requested.

5. Complete shipping instructions for return of equipment.

- d. Enclose a cover letter and purchase order, and ship the defective equipment according to instructions provided in Rosemount Return Authorization, prepaid to:

Rosemount Analytical Inc.
R.M.R. Department
1201 N. Main Street
Orrville, Ohio 44667

6-2 REPAIR TERMS

- a. If warranty service is requested, the defective unit will be carefully tested and inspected at the factory. If failure was due to conditions listed in the standard Rosemount warranty, the defective unit will be repaired or replaced at Rosemount's option, and an operating unit will be returned to the customer in accordance with shipping instructions furnished in the cover letter.
- b. For equipment no longer under warranty, the equipment will be repaired at the factory and returned as directed by the purchase order and shipping instructions.

Instruction Manual

IB-102-202N Rev. 1.2

January 2003

Hagan 2-1/2 x 5 Power Positioner

SECTION 7 REPLACEMENT PARTS

The following tables give listings of replacement parts for standard and on/off 2-1/2 inch x 5 inch power positioners, and for the standard pilot valve assembly.

Table 7-1. Recommended Spare Parts for the Standard Power Positioner

Figure and Index No.	Part Number	Description	Quantity
Figure 5-1, 12	152507-001	Seal	1
Figure 5-1, 17	4847B17H01	Cylinder Head Gasket	2
Figure 5-1, 22	170857	Piston Cup	2
Figure 4-1, 14 and 15	173283	Stem and Sleeve Assembly (Matched Set)	1
(Not shown)	3D39395G07	Maintenance Tool Kit	1

Table 7-2. Recommended Spare Parts for the On/Off Power Positioner

Figure and Index No.	Part Number	Description	Quantity
Figure 5-1, 12	152507-001	Seal	1
Figure 5-1, 17	4847B17H01	Cylinder Head Gasket	2
Figure 5-1, 22	170857	Piston Cup	2
Figure 4-2	ASCO #8340A2	Solenoid Valve Assembly	1
(Not shown)	3D39395G07	Maintenance Tool Kit	1

NOTE

Order replacement parts for the solenoid valve assembly directly from ASCO at the following address:

**ASCO Valves
Automatic Switch Co.
Florham Park, NJ 07932**

Table 7-3. Recommended Spare Parts for the Standard Pilot Valve Assembly

Figure and Index No.	Part Number	Description	Quantity
Figure 4-1, 9	171323	Bottom Diaphragm	1
Figure 4-1, 6	170960	Top Diaphragm	1

NOTE

Table 7-4, Bill of Material for the 2-1/2 x 5 Power Positioner, includes part numbers and descriptions that are keyed to figure and index number references. The table covers all basic positioner parts. Refer to Table 7-1, Table 7-2, and Table 7-3 for recommended spare parts.

Table 7-4. Bill of Materials for the 2-1/2 x 5 Power Positioner

Figure and Index No.	Part Number	Description	Quantity	
Figure 5-1,	1	120079-010	Retaining Ring	2
	2	170924	Clevis Pin	1
	3	170925-002	Clevis	1
	4	120036-014	Hex Nut, 0.625-18	1
	5	4847B25H01	Piston Rod	1
	6	4513C25H02	Positioner Arm	1
	7	120090-250125	Socket Head Cap Screw, 0.250-20 x 1.25 long	1
	8		Calibration Spring (1 of 3 Tensions)	1
		170952	0 - 30 lb Spring	—
		171267	3 - 15 lb Spring	—
		171266	3 - 27 lb Spring	—
	9	163792-1932038	Cap Screw	2
	10	120114-017	Lockwasher, #10	2
	11	170949	Seal Retainer	1
	12	152507-001	Seal	1
	13	120026-019	Hex Nut, 0.312-24	4
	14	120114-029	Lockwasher	4
	15	4847B35G01	Top Head Assembly	1
	16	771B867H01	Elbow Fitting	4
	17	4847B17H01	Cylinder Head Gasket	2
	18	3D39399H05	Top Tubing, 18" long, 1/8" 304 S.S.	1
	19	4847B29H01	Cylinder	1
	20	170941	Garner Spring	2
	21	170942	Piston Cup Follower	2
	22	170857	Piston Cup	2
	23	3D39399H02	Bottom Tubing, 9" long, 1/8" 304 S.S.	1
24	120110-005	Washer, 0.500 Plain	1	
25	120171-002	Elastic Stop Nut	1	
26		Bottom Cylinder Head (1 of 2 Designs)	1	
	4846B57G02	Bottom Cylinder Head, G05 Group	—	
	4847B34G01	Bottom Cylinder Head, G06/G08 Groups	—	
27	3D39398	Pilot Valve Assembly	1	
Figure 4-1,	1		Socket Head Cap Screw	2
	2	4847B19H01	Rubber Boot	1
	3	4847B55H02	Top Spring Retainer, Standard	1
		4844B16H01	Top Spring Retainer, EPT Option	1
		173217-001	Top Diaphragm Cover, EPT Option	1
	4	170964	Top Loading Spring	1
	5	4847B82H01	Top Diaphragm Seat	1
	6	170960	Top Diaphragm	1
	7	4847B20H01	Center Block	1
8	4847B22H01	Center Diaphragm Post	1	
9	171323	Bottom Diaphragm	1	

Hagan 2-1/2 x 5 Power Positioner

Table 7-4. Bill of Materials for the 2-1/2 x 5 Power Positioner (Continued)

Figure and Index No.	Part Number	Description	Quantity
Figure 4-1, 10	170959	Bottom Diaphragm Seat	1
11	4847B21	Top Stem Seat	1
12	3D39396H02	Valve Body	1
13		O-Rings	4
	173283	Stem and Sleeve Assembly	1
14		Sleeve	1
15		Stem	1
16	170955	Bottom Stem Seat	1
17	170958	Bottom Loading Spring	1
18	170968	Sleeve Retainer	1
Figure 5-1, 28	174080-003	Tie Rod, 0.312-24 x 9.38 long	4
Figure 4-3	3534B98G01	Limit Switch Field Retrofit Kit, includes parts 1 through 7:	1
1		Limit Switch	2
2		Switch Striker	1
3		Switch Bracket	2
4		Pan Head Screw, 0.138-32 Thread	4
5		Washer, #6 Flat	4
6		Lockwasher, #6 Split	4
7		Nut Plate, 0.138-32 Thread	2
	3534B98	Instructions, Limit Switch Kit	1
Figure 4-2	ASCO #8340A2	Solenoid Valve Assembly (On/Off Units only)	1

Instruction Manual

IB-102-202N Rev. 1.2

January 2003

Hagan 2-1/2 x 5 Power Positioner

Hagan 2-1/2 x 5 Power Positioner

SECTION 8 INDEX

This index is an alphabetized listing of parts, terms, and procedures having to do with the Hagan 2-1/2 x 5 Power Positioner. Every item listed in this index refers to a location in the manual by one or more page numbers.

A

Active Coils, 2-5
Adjustment of Standard Units, 2-4
Air Filter, 2-1, 4-1, 4-3
Ambient Temperature, 2-1

C

Calibration Spring, 3-3
Clevis, 1-1, 2-1
Clevis Pin, 2-1
Control Signal, 2-4, 3-1, 3-3
Control System, 4-5
Cylinder, 1-1, 4-3, 4-5, 4-7, 5-1

D

Damper, 1-1
Diaphragm, 3-1, 4-5, 5-2
Diaphragm Assembly, 3-1

E

Equation, 2-5, 2-6

G

Guide Bearings, 3-1

I

Installation, 2-1

L

Limit Switch, 1-2, 2-4, 2-6, 4-7, 4-8
Lower Limit, 2-4

M

Maintenance, 4-1, 4-3
Mounting Pivot, 2-1, 5-1
Mounting Pivot Pin, 2-1

O

On/Off Standard Option, 3-3

P

Pilot Valve, 1-1, 3-1, 5-1
Piston, 1-1, 3-1, 3-3
Piston Cups, 3-1, 4-6, 5-2
Piston Rod Seal, 4-5, 5-2
Power Air, 1-1, 3-1, 5-1, 5-2, 5-3

R

Replacement Parts, 7-1

S

Shutoff Valve, 2-1
Sleeve, 4-1, 5-1
Sleeve and Stem, 3-1, 4-1
Solenoid Operated Valve, 3-3
Solenoid Valve, 1-2, 4-3, 5-3
Stem, 3-1, 4-1, 5-1

U

Upper Limit, 2-4

W

Wiring, 2-4

Instruction Manual

IB-102-202N Rev. 1.2

January 2003

Hagan 2-1/2 x 5 Power Positioner

WARRANTY

Rosemount warrants that the equipment manufactured and sold by it will, upon shipment, be free of defects in workmanship or material. Should any failure to conform to this warranty become apparent during a period of one year after the date of shipment, Rosemount shall, upon prompt written notice from the purchaser, correct such nonconformity by repair or replacement, F.O.B. factory of the defective part or parts. Correction in the manner provided above shall constitute a fulfillment of all liabilities of Rosemount with respect to the quality of the equipment.

THE FOREGOING WARRANTY IS EXCLUSIVE AND IN LIEU OF ALL OTHER WARRANTIES OF QUALITY WHETHER WRITTEN, ORAL, OR IMPLIED (INCLUDING ANY WARRANTY OF MERCHANTABILITY OF FITNESS FOR PURPOSE).

The remedy(ies) provided above shall be purchaser's sole remedy(ies) for any failure of Rosemount to comply with the warranty provisions, whether claims by the purchaser are based in contract or in tort (including negligence).

Rosemount does not warrant equipment against normal deterioration due to environment. Factors such as corrosive gases and solid particulates can be detrimental and can create the need for repair or replacement as part of normal wear and tear during the warranty period.

Equipment supplied by Rosemount Analytical Inc. but not manufactured by it will be subject to the same warranty as is extended to Rosemount by the original manufacturer.

At the time of installation it is important that the required services are supplied to the system and that the electronic controller is set up at least to the point where it is controlling the sensor heater. This will ensure, that should there be a delay between installation and full commissioning that the sensor being supplied with ac power and reference air will not be subjected to component deterioration.

Instruction Manual

IB-102-202N Rev. 1.2

January 2003

Hagan 2-1/2 x 5 Power Positioner

Emerson Process Management

Rosemount Analytical Inc. Process Analytic Division

1201 N. Main St.
Orrville, OH 44667-0901
T (330) 682-9010
F (330) 684-4434
E gas.csc@emersonprocess.com

Fisher-Rosemount GmbH & Co.

Industriestrasse 1
63594 Hasselroth
Germany
T 49-6055-884 0
F 49-6055-884209

ASIA - PACIFIC

Fisher-Rosemount Singapore Private Ltd.

1 Pandan Crescent
Singapore 128461
Republic of Singapore
T 65-777-8211
F 65-777-0947

<http://www.processanalytic.com>

EUROPE, MIDDLE EAST, AFRICA

Fisher-Rosemount Ltd.

Heath Place
Bognor Regis
West Sussex PO22 9SH
England
T 44-1243-863121
F 44-1243-845354

LATIN AMERICA

Fisher - Rosemount

Av. das Americas
3333 sala 1004
Rio de Janeiro, RJ
Brazil 22631-003
T 55-21-2431-1882



EMERSON[™]
Process Management