

Rosemount 8732

Integral Mount or Remote Mount Magnetic Flowmeter System



ROSEMOUNT[®]

www.rosemount.com

EMERSON[™]
Process Management

Integral Mount or Remote Mount Magnetic Flowmeter System

NOTICE

Read this manual before working with the product. For personal and system safety, and for optimum product performance, make sure you thoroughly understand the contents before installing, using, or maintaining this product.

Rosemount Inc. has two toll-free assistance numbers:

Customer Central

Technical support, quoting, and order-related questions.

United States - 1-800-522-6277 (7:00 am to 7:00 pm CST)

Asia Pacific- 65 777 8211

Europe/ Middle East/ Africa - 49 (8153) 9390

North American Response Center

Equipment service needs.

1-800-654-7768 (24 hours—includes Canada)

Outside of these areas, contact your local Rosemount representative.

⚠ CAUTION

The products described in this document are NOT designed for nuclear-qualified applications. Using non-nuclear qualified products in applications that require nuclear-qualified hardware or products may cause inaccurate readings.

For information on Rosemount nuclear-qualified products, contact your local Rosemount Sales Representative.

Table of Contents

| | | |
|--|---|------|
| SECTION 1 Introduction | System Description | 1-1 |
| | Safety Messages | 1-2 |
| | Service Support | 1-2 |
| SECTION 2 Installation | Safety Messages | 2-1 |
| | Transmitter Symbols | 2-2 |
| | Pre-Installation | 2-2 |
| | Mechanical Considerations | 2-2 |
| | Environmental Considerations | 2-4 |
| | Installation Procedures | 2-4 |
| | Mount the Transmitter | 2-4 |
| | Identify Options and Configurations | 2-4 |
| | Installing a Local Operator Interface (LOI) | 2-5 |
| | Hardware Switches | 2-5 |
| | Conduit Ports and Connections | 2-7 |
| | Conduit Cables | 2-8 |
| | Electrical Considerations | 2-8 |
| | Installation Category | 2-10 |
| | Overcurrent Protection | 2-10 |
| | Options, Considerations, and Procedures | 2-10 |
| | Connect Transmitter Power | 2-10 |
| | Connect 4–20 mA Loop External Power Source | 2-11 |
| | Connect Pulse Output Power Source | 2-12 |
| | Connect Digital or Discrete Output | 2-15 |
| | Connect Digital Input | 2-16 |
| | Sensor Connections | 2-18 |
| | Rosemount Sensors | 2-18 |
| Transmitter to Sensor Wiring | 2-18 | |
| Conduit Cables | 2-19 | |
| Sensor to Remote Mount Transmitter Connections | 2-20 | |
| SECTION 3 Configuration | Introduction | 3-1 |
| | Local Operator Interface | 3-1 |
| | Basic Features | 3-1 |
| | Data Entry | 3-2 |
| | LOI Examples | 3-2 |
| | Table Value Example | 3-3 |
| | Select Value Example | 3-3 |
| | Display Lock | 3-3 |
| | Start Totalizer | 3-3 |
| | Stop Totalizer | 3-3 |
| | Reset Totalizer | 3-3 |
| | Diagnostic Messages | 3-4 |
| | Review | 3-4 |
| | Process Variables | 3-5 |
| | PV - Primary Variable | 3-5 |
| | PV -% Range | 3-5 |
| | PV - Analog Output | 3-5 |
| Totalizer Setup | 3-5 | |
| Pulse Output | 3-6 | |

| | | |
|----------------------------|--|------|
| | Basic Setup | 3-6 |
| | Tag | 3-6 |
| | Flow Units | 3-6 |
| | Line Size | 3-9 |
| | PV URV (Upper Range Value) | 3-9 |
| | PV LRV (Lower Range Value) | 3-9 |
| SECTION 4 | | |
| Operation | | |
| | Introduction | 4-1 |
| | Diagnostics | 4-1 |
| | Diagnostic Controls | 4-1 |
| | Basic Diagnostics | 4-3 |
| | Advanced Diagnostics | 4-5 |
| | Diagnostic Variable Values | 4-5 |
| | Trims | 4-9 |
| | Status | 4-11 |
| | Advanced Configuration | 4-11 |
| | Detailed Setup | 4-12 |
| | Additional Parameters | 4-12 |
| | Configure Outputs | 4-13 |
| | LOI Configuration | 4-29 |
| | Signal Processing | 4-30 |
| | Universal Trim | 4-32 |
| | Device Info | 4-33 |
| SECTION 5 | | |
| Sensor Installation | | |
| | Safety Messages | 5-1 |
| | Sensor Handling | 5-3 |
| | Sensor Mounting | 5-4 |
| | Upstream/Downstream | |
| | Piping | 5-4 |
| | Sensor Orientation | 5-4 |
| | Flow Direction | 5-6 |
| | Installation (Flanged Sensor) | 5-7 |
| | Gaskets | 5-7 |
| | Flange Bolts | 5-7 |
| | Installation | |
| | (Wafer Sensor) | 5-10 |
| | Gaskets | 5-10 |
| | Flange Bolts | 5-11 |
| | Installation | |
| | (Sanitary Sensor) | 5-12 |
| | Gaskets | 5-12 |
| | Alignment and Bolting | 5-12 |
| | Grounding | 5-12 |
| | Process Leak Protection (Optional) | 5-15 |
| | Standard Housing Configuration | 5-15 |
| | Relief Valves | 5-16 |
| | Process Leak Containment | 5-17 |

SECTION 6
Maintenance and
Troubleshooting

Safety Information 6-1
Installation Check and Guide 6-2
Diagnostic Messages 6-3
Transmitter Troubleshooting 6-7
Quick Troubleshooting 6-9
 Step 1: Wiring Errors 6-9
 Step 2: Process Noise 6-9
 Step 3: Installed Sensor Tests 6-9
 Step 4: Uninstalled Sensor Tests 6-11

APPENDIX A
Reference Data

Rosemount 8732 Transmitter Specifications A-1
Functional Specifications A-1
Performance Specifications A-7
Physical Specifications A-9

APPENDIX B
Approval
Information

Product Certifications B-1
 Approved Manufacturing Locations B-1
European Directive Information B-1
 ATEX Directive B-1
 European Pressure Equipment Directive (PED) (97/23/EC) B-2
 Electro Magnetic Compatibility (EMC) (2004/108/EC) B-2
 Low Voltage Directive (2006/95/EC) B-3
 Other important guidelines B-3
 IECEX Certificates B-3
Hazardous Locations Product Approvals Offering B-4
Hazardous Location Certifications B-8
 International Certifications B-10
 Sensor Approval Information B-13

APPENDIX C
Diagnostics

Diagnostic Availability C-1
Licensing and Enabling C-2
 Licensing the 8732 Diagnostics C-2
Tunable Empty Pipe Detection C-3
 Tunable Empty Pipe Parameters C-3
 Optimizing Tunable Empty Pipe C-4
 Troubleshooting Empty Pipe C-4
Ground/Wiring Fault Detection C-4
 Ground/Wiring Fault Parameters C-5
 Troubleshooting Ground/Wiring Fault C-5
 Ground/Wiring Fault Functionality C-5
High Process Noise Detection C-6
 High Process Noise Parameters C-6
 Troubleshooting High Process Noise C-6
 High Process Noise Functionality C-7
Coated Electrode Detection C-8
Coated Electrode Parameters C-8
Troubleshooting Coated Electrode Detection C-9
4-20 mA Loop Verification C-9
 4-20 mA Loop Verification Parameters C-10
 Troubleshooting 4-20 mA Loop Verification C-10
 4-20 mA Loop Verification Functionality C-10

Rosemount 8732

| | | |
|---|---|------|
| | Smart Meter Verification (8714i) | C-10 |
| | Sensor Signature Parameters | C-11 |
| | Smart Meter Verification (8714i) Test Parameters | C-11 |
| | Smart Meter Verification (8714i) Test Results Parameters | C-14 |
| | Optimizing the Smart Meter Verification (8714i). | C-18 |
| | Optimizing Continuous Smart Meter Verification | C-19 |
| | Troubleshooting the Smart Meter Verification (8714i) Test | C-19 |
| | Smart Meter Verification (8714i) Functionality | C-20 |
| | Calibration Verification Report. | C-22 |
| APPENDIX D | | |
| Digital Signal Processing | Safety Messages | D-1 |
| | Warnings | D-1 |
| | Procedures | D-2 |
| | Auto Zero | D-2 |
| | Signal Processing. | D-2 |
| APPENDIX E | | |
| Universal Sensor Wiring Diagrams | Rosemount Sensors | E-3 |
| | Rosemount 8705/8707/8711/8721 Sensors to Rosemount 8732 Transmitter. | E-3 |
| | Rosemount 8701 Sensor to Rosemount 8732 Transmitter | E-4 |
| | Connecting Sensors of Other Manufacturers | E-4 |
| | Brooks Sensors | E-6 |
| | Endress And Hauser Sensors | E-8 |
| | Fischer And Porter Sensors. | E-9 |
| | Foxboro Sensors | E-15 |
| | Kent Veriflux VTC Sensor | E-19 |
| | Kent Sensors | E-20 |
| | Krohne Sensors. | E-21 |
| | Taylor Sensors. | E-22 |
| | Yamatake Honeywell Sensors. | E-24 |
| | Yokogawa Sensors | E-25 |
| | Generic Manufacturer Sensors | E-26 |
| | Generic Manufacturer Sensor to Rosemount 8732 Transmitter. | E-26 |
| | Identify the Terminals | E-26 |
| | Wiring Connections | E-26 |

Section 1 Introduction

| | |
|--------------------------|----------|
| System Description | page 1-1 |
| Safety Messages | page 1-2 |
| Service Support | page 1-2 |

SYSTEM DESCRIPTION

The Rosemount® 8700 Series Magnetic Flowmeter System consists of a sensor and transmitter, and measures volumetric flow rate by detecting the velocity of a conductive liquid that passes through a magnetic field.

There are four Rosemount magnetic flowmeter sensors:

- Flanged Rosemount 8705
- Flanged High-Signal Rosemount 8707
- Wafer-Style Rosemount 8711
- Sanitary Rosemount 8721

There are two Rosemount magnetic flowmeter transmitters:

- Rosemount 8712
- Rosemount 8732

The sensor is installed in-line with process piping — either vertically or horizontally. Coils located on opposite sides of the sensor create a magnetic field. Electrodes located perpendicular to the coils make contact with the process fluid. A conductive liquid moving through the magnetic field generates a voltage at the two electrodes that is proportional to the flow velocity.

The transmitter drives the coils to generate a magnetic field and electronically conditions the voltage detected by the electrodes to provide a flow signal. The transmitter can be integrally or remotely mounted from the sensor.

This manual is designed to assist in the installation and operation of the Rosemount 8732 Magnetic Flowmeter Transmitter and the Rosemount 8700 Series Magnetic Flowmeter Sensors.

Rosemount 8732

SAFETY MESSAGES

Procedures and instructions in this manual may require special precautions to ensure the safety of the personnel performing the operations. Refer to the safety messages listed at the beginning of each section before performing any operations.

WARNING

Attempting to install and operate the Rosemount 8705, Rosemount 8707 High-Signal, Rosemount 8721, or Rosemount 8711 Magnetic Sensors with the Rosemount 8712 or Rosemount 8732 Magnetic Flowmeter Transmitters without reviewing the instructions contained in this manual could result in personal injury or equipment damage.

SERVICE SUPPORT

To expedite the return process outside the United States, contact the nearest Rosemount representative.

Within the United States and Canada, call the North American Response Center using the 800-654-RSMT (7768) toll-free number. The Response Center, available 24 hours a day, will assist you with any needed information or materials.

The center will ask for product, model, and serial numbers and will provide a Return Material Authorization (RMA) number. The center will also ask for the name of the process material to which the product was last exposed.



Mishandling products exposed to a hazardous substance may result in death or serious injury. If the product being returned was exposed to a hazardous substance as defined by OSHA, a copy of the required Material Safety Data Sheet (MSDS) for each hazardous substance identified must be included with the returned goods.

The North American Response Center will detail the additional information and procedures necessary to return goods exposed to hazardous substances.



See "Safety Messages" on page D-1 for complete warning information.

Section 2 Installation

| | |
|---|-----------|
| Safety Messages | page 2-1 |
| Transmitter Symbols | page 2-2 |
| Pre-Installation | page 2-2 |
| Installation Procedures | page 2-4 |
| Options, Considerations, and Procedures | page 2-10 |
| Sensor Connections | page 2-18 |

This section covers the steps required to physically install the magnetic flowmeter. Instructions and procedures in this section may require special precautions to ensure the safety of the personnel performing the operations. Please refer to the following safety messages before performing any operation in this section.

SAFETY MESSAGES

 This symbol is used throughout this manual to indicate that special attention to warning information is required.

 WARNING

Failure to follow these installation guidelines could result in death or serious injury:

Installation and servicing instructions are for use by qualified personnel only. Do not perform any servicing other than that contained in the operating instructions, unless qualified. Verify that the operating environment of the sensor and transmitter is consistent with the appropriate hazardous area approval.

Do not connect a Rosemount 8732 to a non-Rosemount sensor that is located in an explosive atmosphere.

 WARNING

Explosions could result in death or serious injury:

Installation of this transmitter in an explosive environment must be in accordance with the appropriate local, national, and international standards, codes, and practices. Please review the approvals section of the 8732 reference manual for any restrictions associated with a safe installation.

Before connecting a handheld communicator in an explosive atmosphere, make sure the instruments in the loop are installed in accordance with intrinsically safe or non-incendive field wiring practices.

Electrical shock can result in death or serious injury.

Avoid contact with the leads and terminals. High voltage that may be present on leads can cause electrical shock.

⚠ WARNING

The sensor liner is vulnerable to handling damage. Never place anything through the sensor for the purpose of lifting or gaining leverage. Liner damage can render the sensor useless.

To avoid possible damage to the sensor liner ends, do not use metallic or spiral-wound gaskets. If frequent removal is anticipated, take precautions to protect the liner ends. Short spool pieces attached to the sensor ends are often used for protection.

Correct flange bolt tightening is crucial for proper sensor operation and life. All bolts must be tightened in the proper sequence to the specified torque limits. Failure to observe these instructions could result in severe damage to the sensor lining and possible sensor replacement.

Emerson Process Management can supply lining protectors to prevent liner damage during removal, installation, and excessive bolt torquing.

TRANSMITTER SYMBOLS

Caution symbol — check product documentation for details 

Protective conductor (grounding) terminal 

PRE-INSTALLATION

Before installing the Rosemount 8732 Magnetic Flowmeter Transmitter, there are several pre-installation steps that should be completed to make the installation process easier:

- Identify the options and configurations that apply to your application
- Set the hardware switches if necessary
- Consider mechanical, electrical, and environmental requirements

Mechanical Considerations

The mounting site for the 8732 transmitter should provide enough room for secure mounting, easy access to conduit ports, full opening of the transmitter covers, and easy readability of the local operator interface (LOI) screen (see Figure 2-1). The transmitter should be mounted in a manner that prevents moisture in conduit from collecting in the transmitter.

If the 8732 is mounted remotely from the sensor, it is not subject to limitations that might apply to the sensor.

Figure 2-1. Rosemount 8732 Dimensional Drawing

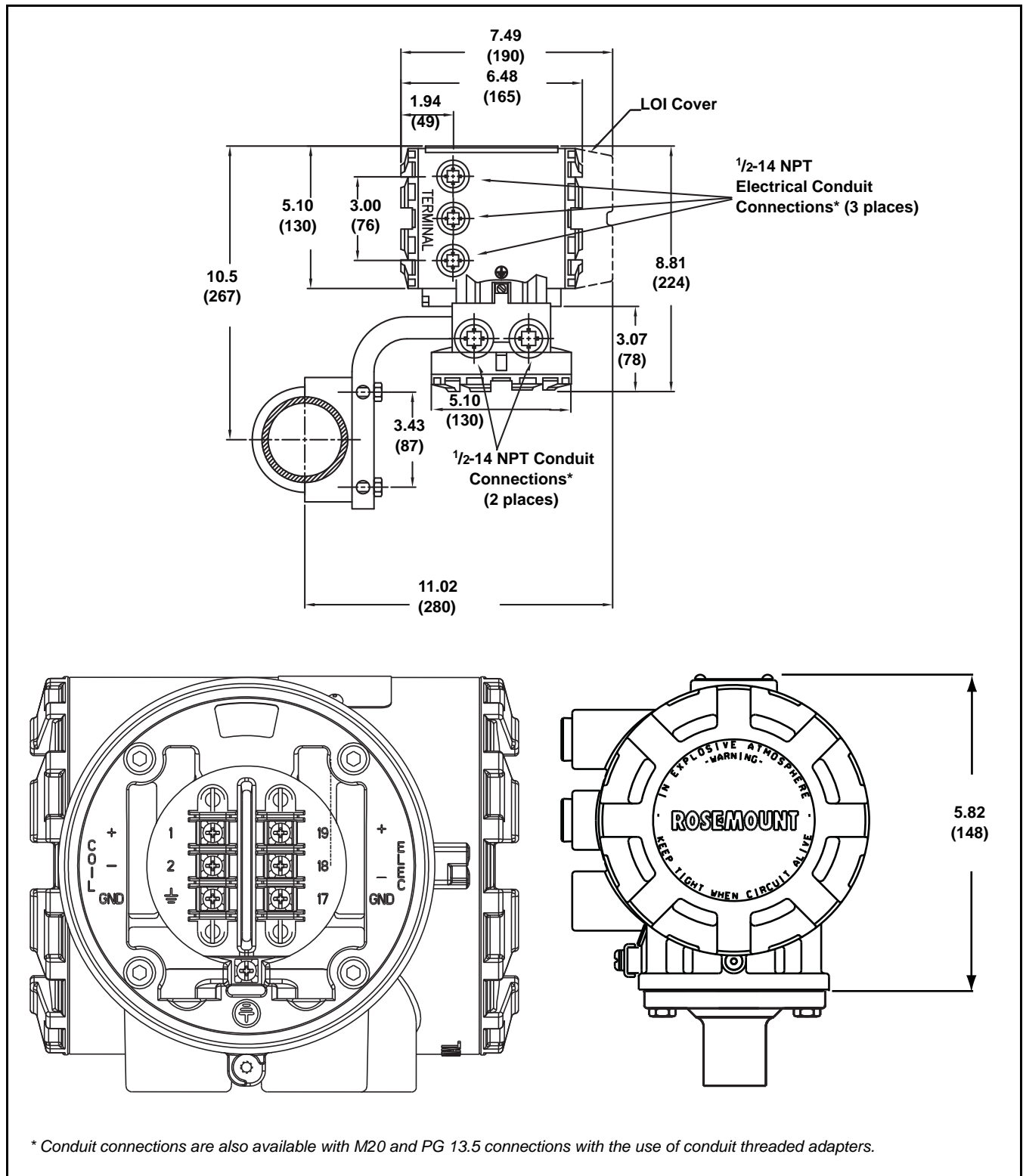

Rosemount 8732

Environmental Considerations

To ensure maximum transmitter life, avoid temperature extremes and vibration. Typical problem areas include:

- high-vibration lines with integrally mounted transmitters
- warm-climate installations in direct sunlight
- outdoor installations in cold climates

Remote-mounted transmitters may be installed in the control room to protect the electronics from a harsh environment and provide easy access for configuration or service.

Rosemount 8732 transmitters require external power so there must be access to a suitable power source.

INSTALLATION PROCEDURES

Rosemount 8732 installation includes both detailed mechanical and electrical installation procedures.

Mount the Transmitter

Remote-mounted transmitters may be mounted on a pipe up to two inches in diameter or against a flat surface.

Pipe Mounting

To mount the transmitter on a pipe:

1. Attach the mounting bracket to the pipe using the mounting hardware.
2. Attach the 8732 to the mounting bracket using the mounting screws.

Surface Mounting

To surface mount the transmitter:

1. Attach the 8732 to the mounting location using the mounting screws. To convert from integral mount to remote mount transmitter, consult Manual Supplement: Integral Mount to Remote Mount Conversion (00809-0300-4727).

Identify Options and Configurations

The standard application of the 8732 includes a 4-20 mA output and control of the sensor coils. Other applications may require one or more of the following configurations or options:

- Multidrop Communication (locks the 4-20 mA output to 4 mA)
- HART Communication
- Pulse Output
- Digital Output
- Digital Input

Additional options may apply. Be sure to identify those options and configurations that apply to your situation, and keep a list of them nearby for consideration during the installation and configuration procedures.

Installing a Local Operator Interface (LOI)

When adding or rotating an LOI, complete the steps below:

1. If the transmitter is installed in a loop, secure the loop and remove power from the transmitter.
2. Remove the flowmeter cover on the electronics side.

NOTE

The circuit board is electrostatically sensitive. Be sure to observe handling precautions for static-sensitive components.

3. On the circuit board stack locate the connector to insert the 20 pin connector that attaches the LOI to the circuit board.
4. Next examine the back of the LOI noting that there are four different places where the 20 pin connector can be inserted. The four pin positions allow the display to be rotated in 90 degree increments providing the best viewing position. Insert the 20 pin connector into one of the four positions on the back of the LOI being careful to not to bend or distort the pin stack.
5. Once the pin connector is installed on the LOI insert the pin connector into the 20 pin socket on the electronics board and tighten the screws into place.
6. Attach the extended cover with the glass viewing pane and tighten at least one-third turn past o-ring contact.

Hardware Switches

The 8732 electronics board is equipped with four user-selectable hardware switches. These switches set the Failure Alarm Mode, Internal/External Analog Power, Transmitter Security, and Internal/External Pulse Power. The standard configuration for these switches when shipped from the factory are as follows:

| | |
|---------------------------------|----------|
| Failure Alarm Mode: | HIGH |
| Internal/External Analog Power: | INTERNAL |
| Transmitter Security: | OFF |
| Internal/External Pulse Power: | EXTERNAL |

NOTE

For electronics with intrinsically safe (I.S. Output) approvals, analog and pulse power must be provided externally. The electronics do not include these hardware switches.

Definitions of these switches and their functions are provided below. If you determine that the settings must be changed, see below.

Failure Alarm Mode

If the 8732 experiences a catastrophic failure in the electronics, the current output can be driven high or low. The switch is set in the *HIGH* position when it is shipped from the factory. Refer to Table 4-1 and Table 4-2.

Internal/External Analog Power

The 8732 4–20 mA loop may be powered internally or by an external power supply. The internal/external power supply switch determines the source of the 4–20 mA loop power.

Transmitters are shipped from the factory with the switch set in the *INTERNAL* position.

The external power option is required for multidrop configurations. A 10–30 Vdc external supply is required and the 4-20 mA power switch must be set to the *EXTERNAL* position. For further information on 4–20 mA external power, see “Connect 4–20 mA Loop External Power Source” on page 2-11.

Transmitter Security

The security switch on the 8732 allows the user to lock out any configuration changes attempted on the transmitter. No changes to the configuration are allowed when the switch is in the *ON* position. The flow rate indication and totalizer functions remain active at all times.

With the switch in the *ON* position, you may still access and review any of the operating parameters and scroll through the available choices, but no actual data changes are allowed.

Transmitter security is set in the *OFF* position when shipped from the factory.

Internal/External Pulse Power

The 8732 pulse loop may be powered internally or by an external power supply. The internal/external power supply switch determines the source of the pulse loop power.

Transmitters are shipped from the factory with the switch set in the *EXTERNAL* position.

A 5-28 Vdc external supply is required when the pulse power switch is set to the *EXTERNAL* position. For further information on the pulse external power, see “Connect Pulse Output Power Source” on page 2-12.

Changing Hardware Switch Settings

In most cases, it is not necessary to change the setting of the hardware switches. If you need to change the switch settings, complete the steps below:

NOTE

The hardware switches are located on the top side of the electronics board and changing their settings requires opening the electronics housing. If possible, carry out these procedures away from the plant environment in order to protect the electronics.

1. Disconnect power to the transmitter.
2. Remove electronics cover.
3. Remove LOI, if applicable.
4. Identify the location of each switch (see Figure 2-2).
5. Change the setting of the desired switches with a small screwdriver.
6. Replace the LOI, if applicable, and the electronics cover.

Figure 2-2. Rosemount 8732
Electronics Board and Hardware
Switches



Conduit Ports and Connections

Both the sensor and transmitter junction boxes have ports for 1/2-inch NPT conduit. Optional CM20 and PG 13.5 connections are available with the use of adapters to convert from 1/2-inch NPT to the desired connection type. These connections should be made in accordance with national, local, or plant electrical codes. Unused ports should be sealed with metal plugs and PTFE tape or other thread sealant. Connections should also be made in accordance with area approval requirements, see examples below for details. Proper electrical installation is necessary to prevent errors due to electrical noise and interference. Separate conduits are not necessary for the coil drive and signal cables connecting the transmitter to the sensor, but a dedicated conduit line between each transmitter and sensor is required. A shielded cable must be used.

Example 1: Installing flanged sensors into an IP68 area. Sensors must be installed with IP68 cable glands and cable to maintain IP68 rating. Unused conduit connections must be properly sealed to prevent water ingress. For added protection, dielectric gel can be used to pot the sensor terminal block. The Rosemount 8732 transmitter is not IP68 rated and should not be mounted in an area that requires IP68 rating, including integral assembly to an IP68 sensor.

Example 2: Installing flowmeters into explosion proof/flameproof areas. Conduit connections and conduit must be rated for use in the hazardous area to maintain flowmeter approval rating.

Rosemount 8732

Conduit Cables

Run the appropriate size cable through the conduit connections in your magnetic flowmeter system. Run the power cable from the power source to the transmitter. Do not run power cables and output signal cables in the same conduit. For remote mount installations, run the coil drive and electrode cables between the flowmeter and transmitter. Refer to Electrical Considerations for wire type. Prepare the ends of the coil drive and electrode cables as shown in Figure 2-3. Limit the unshielded wire length to 1-inch on both the electrode and coil drive cables. Excessive lead length or failure to connect cable shields can create electrical noise resulting in unstable meter readings.

Figure 2-3. Cable Preparation Detail

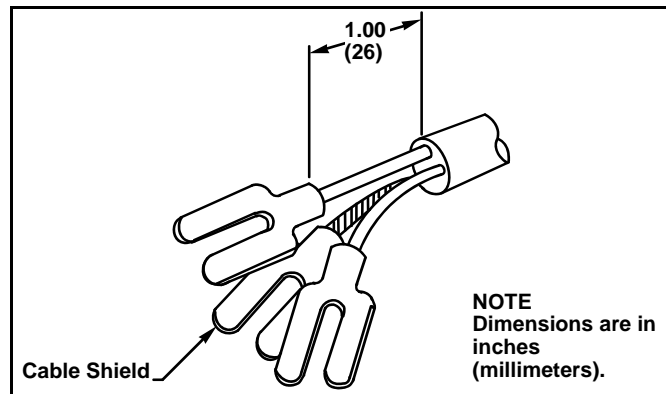

Electrical Considerations

Before making any electrical connections to the Rosemount 8732, consider the following standards and be sure to have the proper power supply, conduit, and other accessories. When preparing all wire connections, remove only the insulation required to fit the wire completely under the terminal connection. Removal of excessive insulation may result in an unwanted electrical short to the transmitter housing or other wire connections.

Transmitter Input Power

The 8732 transmitter is designed to be powered by 90-250 Vac, 50-60 Hz or 12-42 Vdc. The eighth digit in the transmitter model number designates the appropriate power supply requirement.

| Model Number | Power Supply Requirement |
|--------------|--------------------------|
| 1 | 90-250 Vac |
| 2 | 12-42 Vdc |

Supply Wire Temperature Rating

Use 12 to 18 AWG wire. For connections in ambient temperatures exceeding 140 °F (60 °C), use wire rated to at least 194 °F (90 °C).

Disconnects

Connect the device through an external disconnect or circuit breaker. Clearly label the disconnect or circuit breaker and locate it near the transmitter.

Requirements for 90-250 Vac Power Supply

Wire the transmitter according to national, local, and plant electrical requirements for the supply voltage. In addition, follow the supply wire and disconnect requirements on page 2-10.

Requirements for 12-42 Vdc Power Supply

Units powered with 12-42 Vdc may draw up to 1 amp of current. As a result, the input power wire must meet certain gauge requirements.

Figure 2-4 shows the supply current for each corresponding supply voltage. For combinations not shown, you can calculate the maximum distance given the supply current, the voltage of the source, and the minimum start-up voltage of the transmitter, 12 Vdc, using the following equation:

$$\text{MaximumResistance} = \frac{\text{SupplyVoltage} - 12\text{Vdc}}{1\text{amp}}$$

Use Table 2-1 and Table 2-2 to determine the maximum wire length allowable for your power supply and maximum resistance.

Table 2-1. Length of Annealed Copper (Cu) Wires

| Types of Power Supply Wires | | Maximum Length of the Wire for Each Corresponding Power Supply Source | | | |
|-----------------------------|--|---|----------------------|----------------------|------------------------|
| Wire Gauge | Annealed Cu milliohms/ft (milliohms/m) | 42 Vdc Supply ft (m) | 30 Vdc Supply ft (m) | 20 Vdc Supply ft (m) | 12.5 Vdc Supply ft (m) |
| 20 | 0.01015 (0.033292) | 1478 (451) | 887 (270) | 394 (120) | 25 (8) |
| 18 | 0.006385 (0.020943) | 2349 (716) | 1410 (430) | 626 (191) | 39 (12) |
| 16 | 0.004016 (0.013172) | 3735 (1139) | 2241 (683) | 996 (304) | 62 (19) |
| 14 | 0.002525 (0.008282) | 5941 (1811) | 3564 (1087) | 1584 (483) | 99 (30) |
| 12 | 0.001588 (0.005209) | 9446 (2880) | 5668 (1728) | 2519 (768) | 157 (48) |
| 10 | 0.000999 (0.003277) | 15015 (4578) | 9009 (2747) | 4004 (1221) | 250 (76) |

Table 2-2. Length of Hand-drawn Copper (Cu) Wires

| Types of Power Supply Wires | | Maximum Length of the Wire for Each Corresponding Power Supply Source | | | |
|-----------------------------|--|---|----------------------|----------------------|------------------------|
| Wire Gauge | Annealed Cu milliohms/ft (milliohms/m) | 42 Vdc Supply ft (m) | 30 Vdc Supply ft (m) | 20 Vdc Supply ft (m) | 12.5 Vdc Supply ft (m) |
| 18 | 0.00664 (0.021779) | 2259 (689) | 1355 (413) | 602 (184) | 38 (11) |
| 16 | 0.004176 (0.013697) | 3592 (1095) | 2155 (657) | 958 (292) | 60 (18) |
| 14 | 0.002626 (0.008613) | 5712 (1741) | 3427 (1045) | 1523 (464) | 95 (29) |
| 12 | 0.001652 (0.005419) | 9080 (2768) | 5448 (1661) | 2421 (738) | 151 (46) |
| 10 | 0.01039 (0.003408) | 14437 (4402) | 8662 (2641) | 3850 (1174) | 241 (73) |

Rosemount 8732

Figure 2-4. Supply Current versus Input Voltage

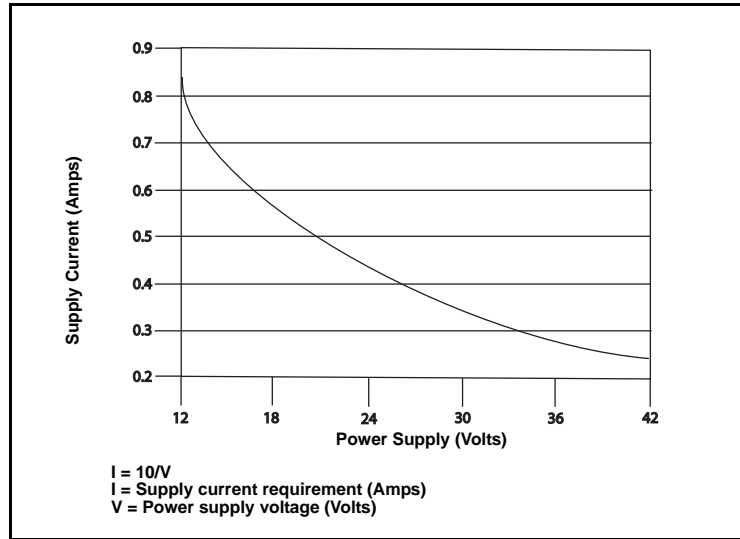

Installation Category

The installation category for the Rosemount 8732 is (overvoltage) Category II.

Overcurrent Protection

The Rosemount 8732 Flowmeter Transmitter requires overcurrent protection of the supply lines. Maximum ratings of overcurrent devices are as follows:

| Power System | Fuse Rating | Manufacturer |
|--------------|----------------------------|----------------------------|
| 110 Vac | 250 V; 1 Amp, Quick Acting | Bussman AGCI or Equivalent |
| 220 Vac | 250 V; 2 Amp, Quick Acting | Bussman AGCI or Equivalent |
| 42 Vdc | 50 V, 3 Amp, Quick Acting | Bussman AGCI or Equivalent |

OPTIONS, CONSIDERATIONS, AND PROCEDURES

If your application of the 8732 includes the use of options such as multidrop communications, DI/DO, or pulse output, certain requirements may apply in addition to those previously listed. Be prepared to meet these requirements before attempting to install and operate the Rosemount 8732.

Connect Transmitter Power

To connect power to the transmitter, complete the following steps.

1. Ensure that the power source and connecting cable meet the requirements outlined on page 2-9.
2. Turn off the power source.
3. Open the power terminal cover.
4. Run the power cable through the conduit to the transmitter.
5. Connect the power cable leads as shown in Figure 2-5.
 - a. Connect AC Neutral or DC- to terminal 9.
 - b. Connect AC Line or DC+ to terminal 10.
 - c. Connect AC Ground or DC Ground to the ground screw mounted inside the transmitter enclosure.

Figure 2-5. AC Transmitter Power Connections

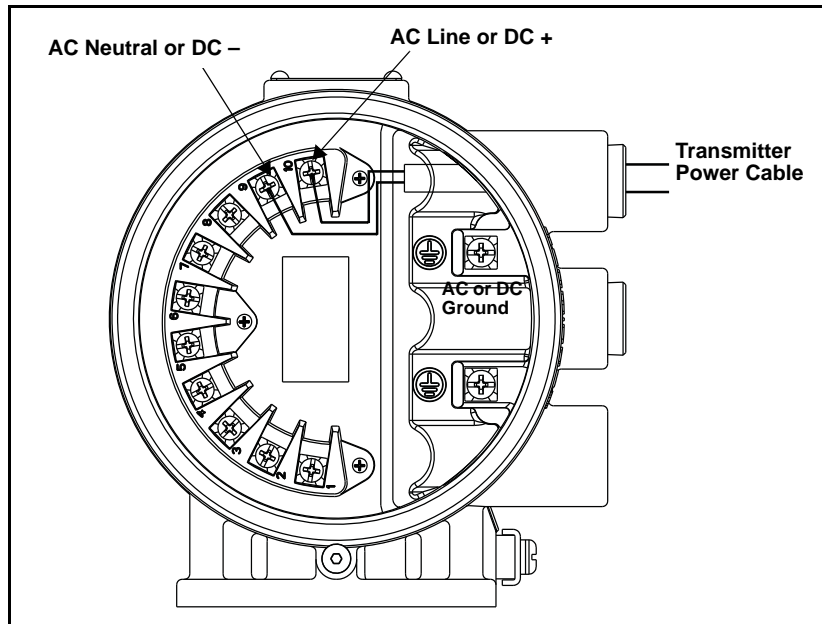

Connect 4–20 mA Loop External Power Source

The 4–20 mA output loop provides the primary process variable output from the transmitter. For transmitters with non-I.S. Output, the signal may be powered internally or externally. The default position of the internal/external analog power switch is in the *INTERNAL* position. The user-selectable power switch is located on the electronics board. The analog output is galvanically isolated from ground.

Figure 2-6. DC Load Limitations (Analog Output)

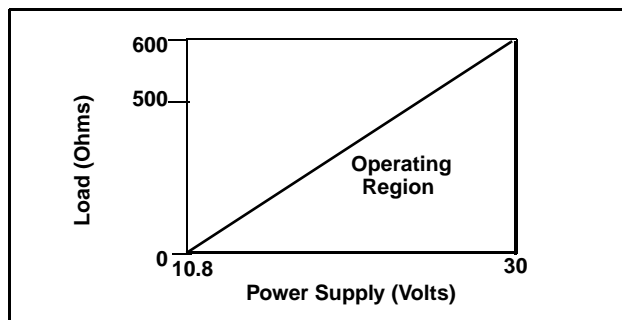

| | |
|-------------|--------------------------------|
| $R_{max} =$ | $31.25 (V_{ps} - 10.8)$ |
| $V_{ps} =$ | Power Supply Voltage (Volts) |
| $R_{max} =$ | Maximum Loop Resistance (Ohms) |

Internal

The 4–20 mA analog power loop may be powered from the transmitter itself. Resistance in the loop must be 600 ohms or less. If a HART communication device or control system will be used, it must be connected across a minimum of 250 ohms resistance in the loop.

External

HART multidrop installations require a 10–30 Vdc external power source. Resistance in the loop must be 1000 ohms or less. If a HART communication device or control system is to be used, it must be connected across a minimum of 250 ohms resistance in the loop.

To connect external power to the 4–20 mA loop, complete the following steps.

1. Ensure that the power source and connecting cable meet the requirements outlined above and in “Electrical Considerations” on page 2-8.
2. Turn off the transmitter and analog power sources.
3. Run the power cable into the transmitter.
4. Connect -4-20 mA power to Terminal 1.
5. Connect +4-20 mA power to Terminal 2.

Refer to Figure 2-7 on page 2-12.

Figure 2-7. 4–20 mA Loop Power Connections

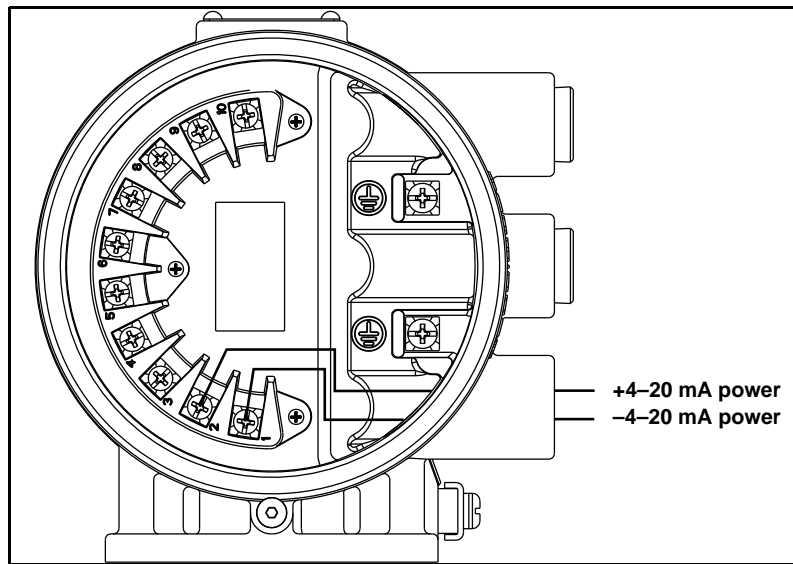

Connect Pulse Output Power Source

The pulse output function provides a galvanically isolated switch-closure frequency signal that is proportional to the flow through the sensor. The signal is typically used in conjunction with an external totalizer or control system. The default position of the internal/external pulse power switch is in the *EXTERNAL* position. The user-selectable power switch is located on the electronics board.

External

For transmitters with the internal/external pulse power switch set in the *EXTERNAL* position, the following requirements apply.

Supply Voltage: 5 to 24 Vdc

Load Resistance: 1,000 to 100 k ohms (typical ≈ 5 k)

Pulse Duration: 1.5 to 500 msec (adjustable), 50% duty cycle below 1.5 msec

Maximum Power: 2.0 watts up to 4,000 Hz and 0.1 watts at 10,000 Hz

Switch Closure: solid state switch

Complete the following steps to connect an external power supply.

1. Ensure that the power source and connecting cable meet the requirements outlined previously.
2. Turn off the transmitter and pulse output power sources.
3. Run the power cable to the transmitter.
4. Connect – DC to terminal 3.
5. Connect + DC to terminal 4.

Refer to Figure 2-8 and Figure 2-9.

Figure 2-8. Connecting to a
Electromechanical
Totalizer/Counter with External
Power Supply

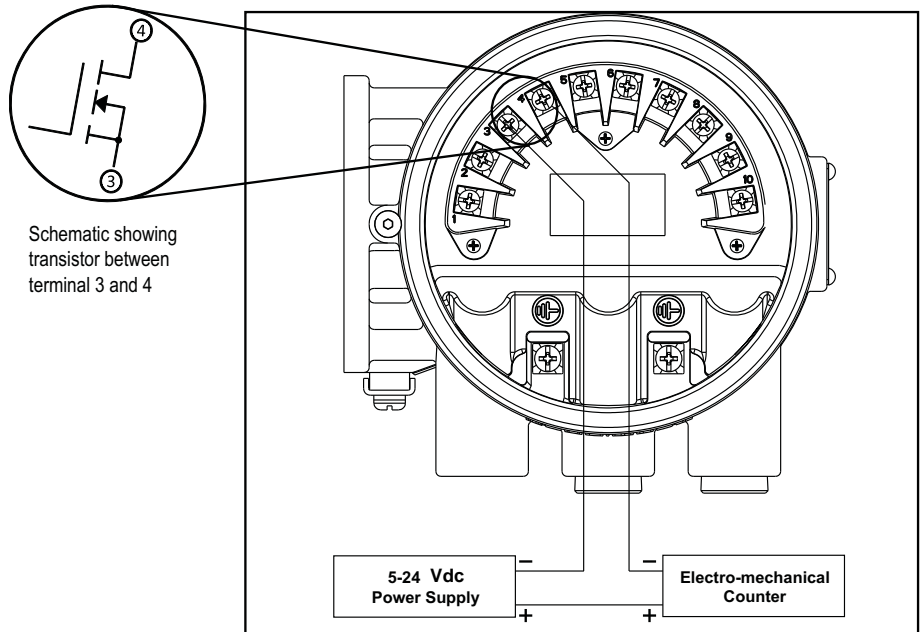

NOTE
Impedance (Z_{in}) of electro-mechanical counter must be a minimum of 60 ohms.

Figure 2-9. Connecting to a Electronic Totalizer/Counter with External Power Supply

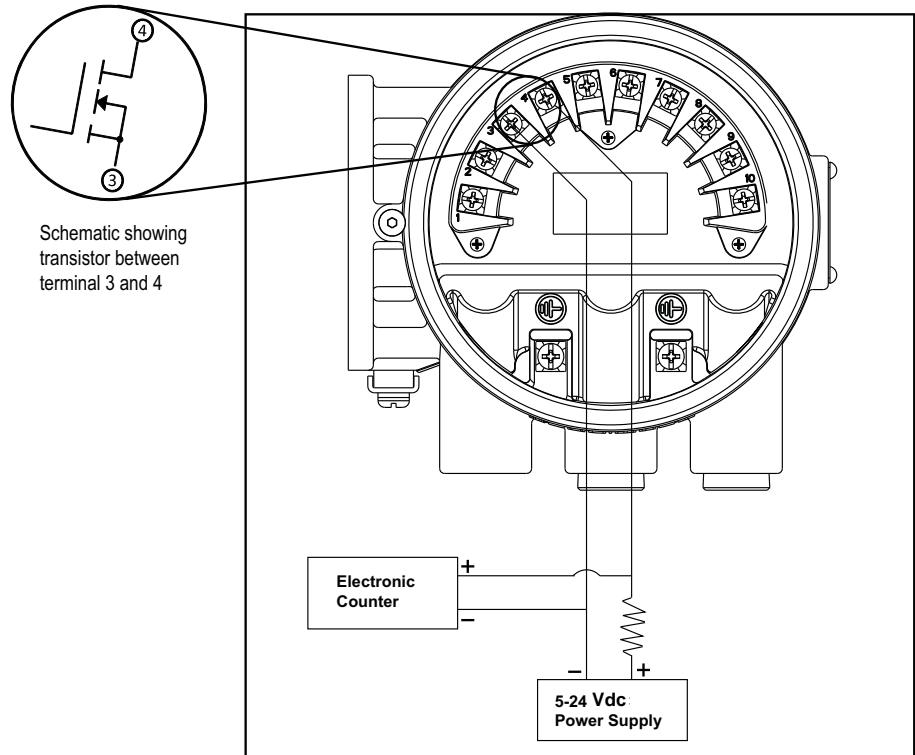

NOTE
Resistor must be in the range of 1,000 to 100k ohms (typically 5k).

Internal

The pulse power loop may be powered from the transmitter itself. Supply voltage from the transmitter is 10 Vdc. Refer to Figure 2-10 and connect the transmitter directly to the counter. Internal pulse power can only be used with an electronic totalizer/counter and cannot be used with an electromechanical counter.

1. Turn off the transmitter.
2. Connect – DC to terminal 3.
3. Connect + DC to terminal 4.

Figure 2-10. Connecting to a
Electronic Totalizer/Counter with
Internal Power Supply

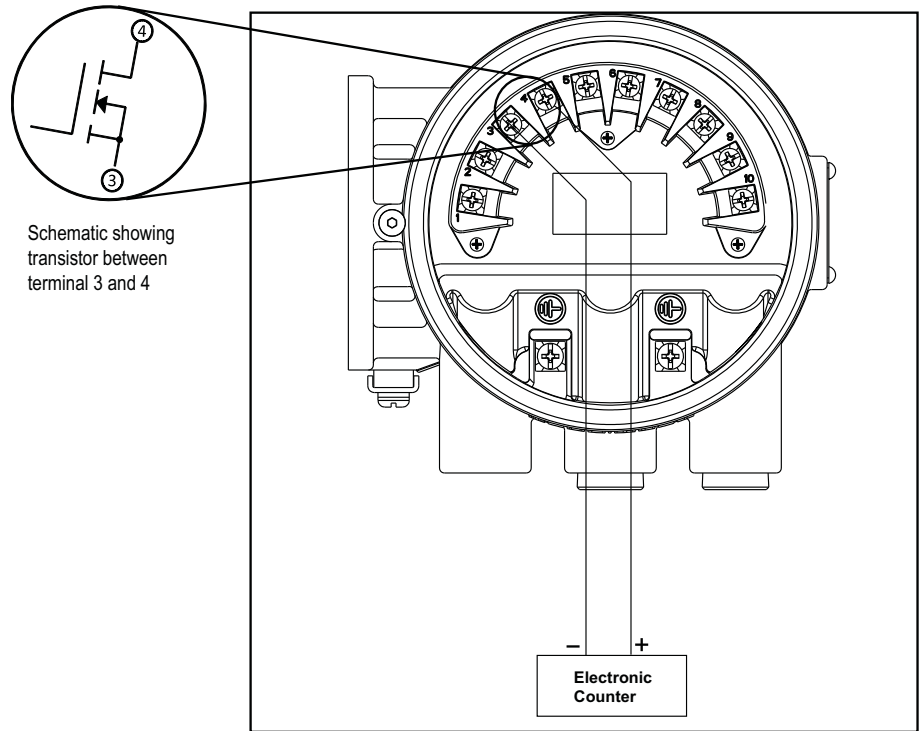

Connect Digital or Discrete Output

The digital output control function allows you to externally signal a zero flow, reverse flow, empty pipe, diagnostic status, flow limit, or transmitter fault condition. The following requirements apply:

- Supply Voltage: 5 to 28 Vdc
Maximum Power: 2 watts
Switch Closure: optically isolated solid state switch

If you are using digital output control, you need to connect the power source and control relay to the transmitter. To connect external power for digital output control, complete the steps:

1. Ensure that the power source and connecting cable meet the requirements outlined previously.
2. Turn off the transmitter and digital power sources.
3. Run the power cable to the transmitter.
4. Connect -DC to terminal 7.
5. Connect +DC to terminal 8.

Refer to Figure 2-11.

Figure 2-11. Connect Digital Output to Relay or Input to Control System

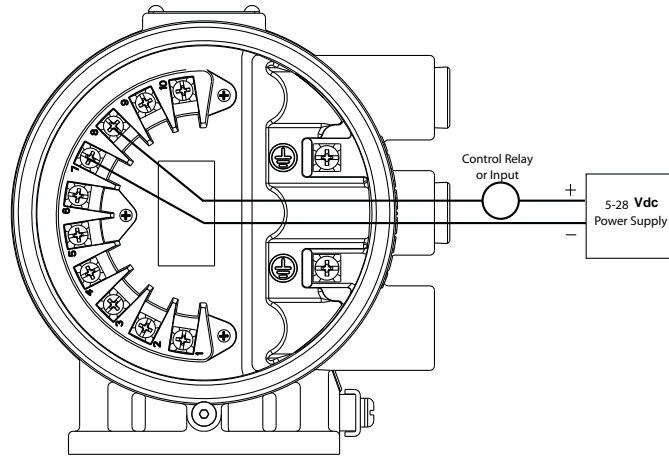
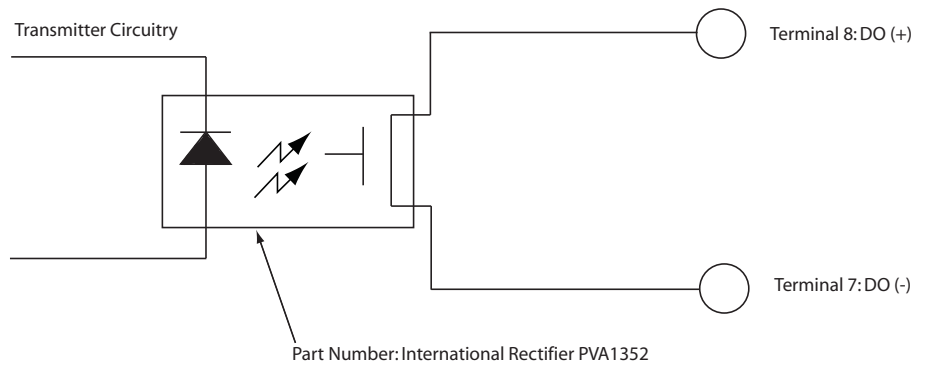

Figure 2-12. Digital Output Schematic



Connect Digital Input

The Digital Input can provide positive zero return (PZR), net totalizer reset, or transmitter reset. The following requirements apply:

- Supply Voltage: 5 to 28 Vdc
- Maximum Power: 2 watts
- Switch Closure: optically isolated solid state switch
- Input Impedance: 2.5 kΩ

To connect the Digital Input, complete the following steps.

1. Ensure that the power source and connecting cable meet the requirements outlined previously.
2. Turn off the transmitter and digital power sources.
3. Run the power cable to the transmitter.
4. Run the 5-28 Vdc signal cable to the transmitter.
5. Connect -DC to terminal 5.
6. Connect +DC to terminal 6.

Refer to Figure 2-13.

NOTE

For installations where Digital Input (DI) is required and the analog output is not required, the DI circuit can be powered by the internal analog source. To wire this connection, connect terminal 1 (-mA) to terminal 5 (-DI), and connect terminal 2 (+mA) to terminal 6 (+DI) with the relay contact in series.

Figure 2-13. Connecting Digital Input

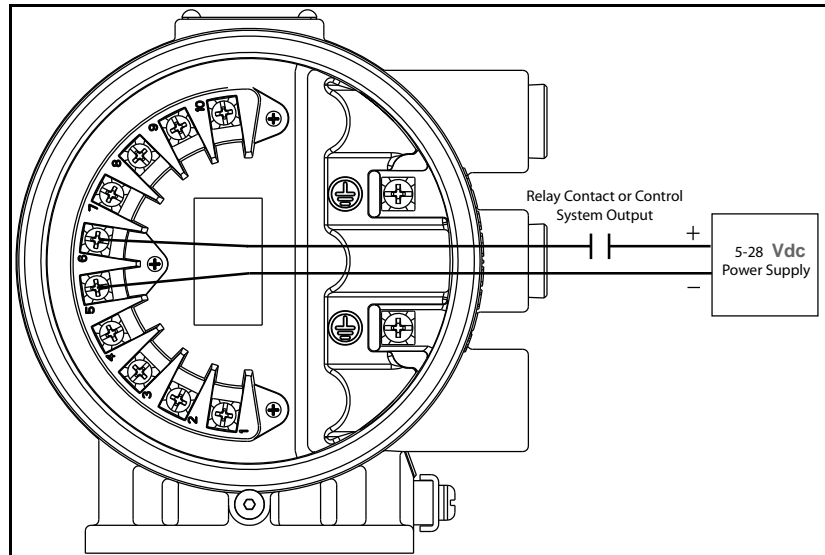

Figure 2-14. Digital Input Schematic

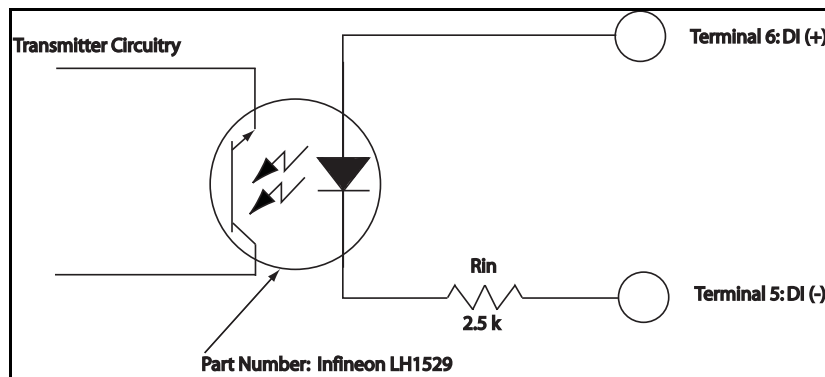
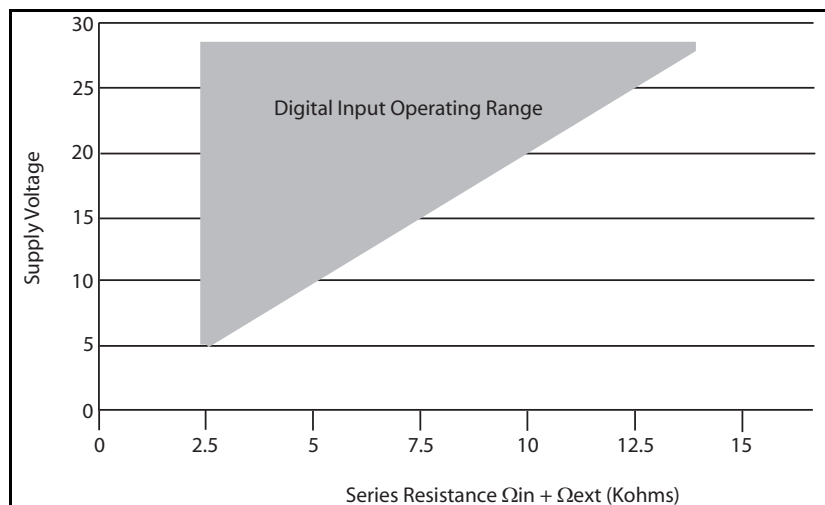

Figure 2-15. Digital Input Operating Range



Rosemount 8732

SENSOR CONNECTIONS

This section covers the steps required to physically install the transmitter including wiring and calibration.

Rosemount Sensors

To connect the transmitter to a non-Rosemount sensor, refer to the appropriate wiring diagram in "Universal Sensor Wiring Diagrams" on page E-1. The calibration procedure listed is not required when used with Rosemount sensors.

Transmitter to Sensor Wiring

Flanged and wafer sensors have two conduit ports as shown in Figure 2-16. Either one may be used for both the coil drive and electrode cables. Use the stainless steel plug that is provided to seal the unused conduit port. Use PTFE tape or thread sealant appropriate for the installation when sealing the conduit.

A single dedicated conduit run for the coil drive and electrode cables is needed between a sensor and a remote transmitter. Bundled cables from multiple magnetic flowmeters in a single conduit are likely to create interference and noise problems in your system. Use one set of cables per conduit run. See Figure 2-16 for the proper conduit installation diagram and Table 2-3 for recommended cable. For integral and remote wiring diagrams refer to Figure 2-19.

Figure 2-16. Conduit Preparation

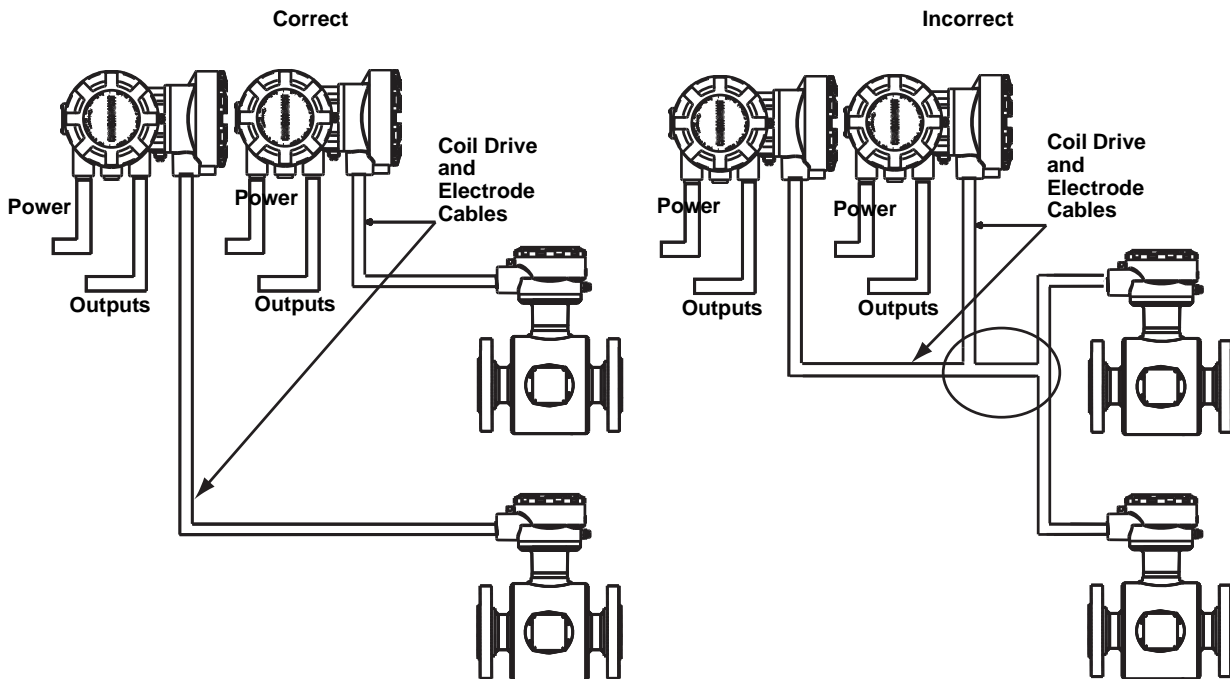

Table 2-3. Cable Requirements

| Description | Units | Part Number |
|--|---------|------------------------------------|
| Signal Cable (20 AWG) Belden 8762, Alpha 2411 equivalent | ft m | 08712-0061-0001 08712-0061-0003 |
| Coil Drive Cable (14 AWG) Belden 8720, Alpha 2442 equivalent | ft m | 08712-0060-0001 08712-0060-0003 |
| Combination Signal and Coil Drive Cable (18 and 20 AWG) ⁽¹⁾ | ft m | 08712-0752-0001 08712-0752-0003 |

(1) Combination signal and coil drive cable is not recommended for high-signal magmeter system. For remote mount installations, combination signal and coil drive cable should be limited to less than 330 ft. (100 m).

Rosemount recommends using the combination signal and coil drive for N5 and E5 approved sensors for optimum performance.

Remote transmitter installations require equal lengths of signal and coil drive cables. Integrally mounted transmitters are factory wired and do not require interconnecting cables.

Lengths from 5 to 1,000 feet (1.5 to 300 meters) may be specified and will be shipped with the sensor.

The specifications table in Table 2-4 identifies the leads and cables in the combination cable shown in Table 2-17. It defines the sensor and transmitter terminals to land the cable. For example, the lead F should be attached to transmitter terminal 1 and lead G should be attached to transmitter terminal 2.

Table 2-4. Specifications Table

| Specifications Table | | | | | | | | | | | |
|----------------------|--------|-----------------|----|------------------------------------|---|------------------------|-----|-------|-------|-------|-------|
| Stranded Conductor | | Drain | | Shield | | Insulator color | | | | | |
| A | B | C | L | D | E | F | G | H | I | J | |
| 18 AWG | 20 AWG | 18 AWG Stranded | | 36 AWG Spiral Strand, 90% Coverage | | A1 FOIL, 100% Coverage | Red | Green | Black | Black | White |
| - | - | ⏏ | 17 | 17 | - | 1 | 2 | 18 | - | 19 | |

Figure 2-17. Combo Cable

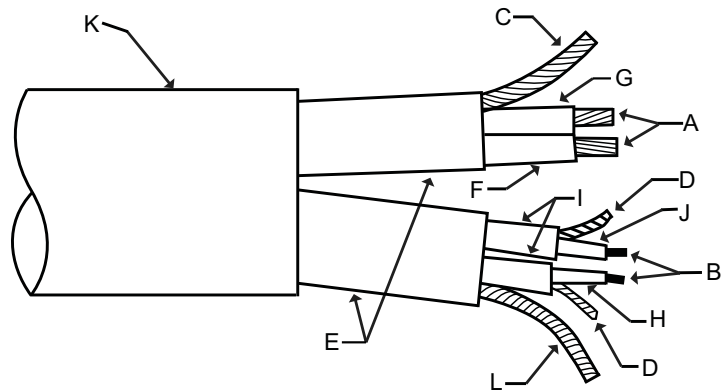

Conduit Cables

Run the appropriate size cable through the conduit connections in your magnetic flowmeter system. Run the power cable from the power source to the transmitter. Run the coil drive and electrode cables between the sensor and transmitter.

Prepare the ends of the coil drive and electrode cables as shown in Figure 2-18. Limit the unshielded wire length to 1-inch on both the electrode and coil drive cables.

NOTE

Excessive lead length or failure to connect cable shields can create electrical noise resulting in unstable meter readings.

Figure 2-18. Cable Preparation Detail

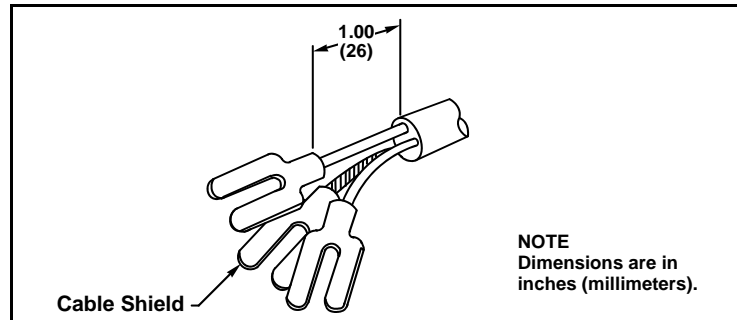

Sensor to Remote Mount Transmitter Connections

Connect coil drive and electrode cables as shown in Figure 2-19.
Do not connect AC power to the sensor or to terminals 1 and 2 of the transmitter, or replacement of the electronics board will be necessary.

Figure 2-19. Wiring Diagram

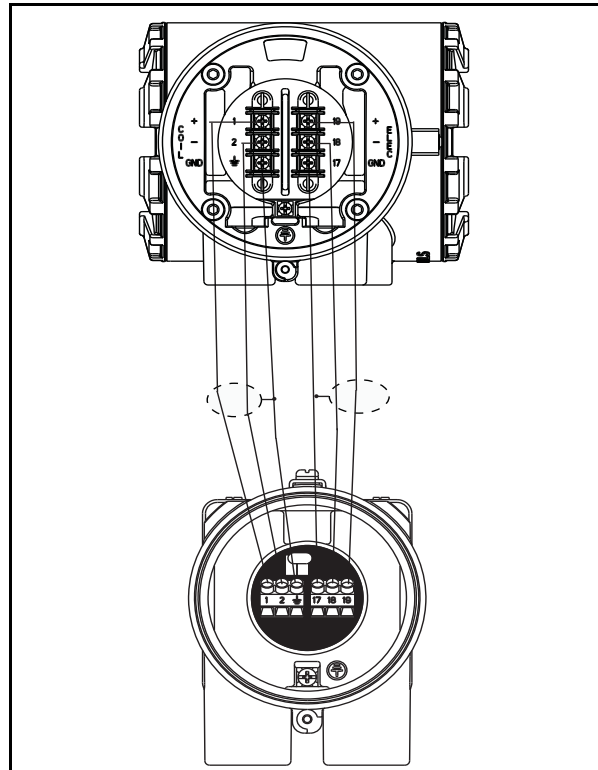

| Rosemount 8732 Transmitter | Rosemount 8705/8707/8711/8721 Sensors |
|----------------------------|---------------------------------------|
| 1 | 1 |
| 2 | 2 |
| ⊥ | ⊥ |
| 17 | 17 |
| 18 | 18 |
| 19 | 19 |

Section 3 Configuration

| | |
|---------------------------------------|-----------------|
| Introduction | page 3-1 |
| Local Operator Interface | page 3-1 |
| Basic Features | page 3-1 |
| LOI Examples | page 3-2 |
| Diagnostic Messages | page 3-4 |
| Process Variables | page 3-5 |
| Basic Setup | page 3-6 |

INTRODUCTION

This section covers basic operation, software functionality, and configuration procedures for the Rosemount 8732 Magnetic Flowmeter Transmitter. For information on connecting another manufacturer's sensor, refer to "Universal Sensor Wiring Diagrams" on page E-1.

The Rosemount 8732 features a full range of software functions for configuration of output from the transmitter. Software functions are accessed through the LOI, AMS Device Manager, a Handheld Communicator, or a control system. Configuration variables may be changed at any time and specific instructions are provided through on-screen instructions.

Table 3-1. Parameters

| Basic Set-up Parameters | Page |
|--------------------------------|-------------|
| Review | page 3-4 |
| Process Variables | page 3-5 |
| Basic Setup | page 3-6 |
| Flow Units | page 3-6 |
| PV URV (Upper Range Value) | page 3-9 |
| PV LRV (Lower Range Value) | page 3-9 |
| Totalizer Setup | page 3-5 |

LOCAL OPERATOR INTERFACE

The optional Local Operator Interface (LOI) provides an operator communications center for the 8732. By using the LOI, the operator can access any transmitter function for changing configuration parameter settings, checking totalized values, or other functions. The LOI is integral to the transmitter electronics.

BASIC FEATURES

The basic features of the LOI include 4 navigational arrow keys that are used to access the menu structure. See Figure 3-1.

Figure 3-1. Local Operator Interface Keypad

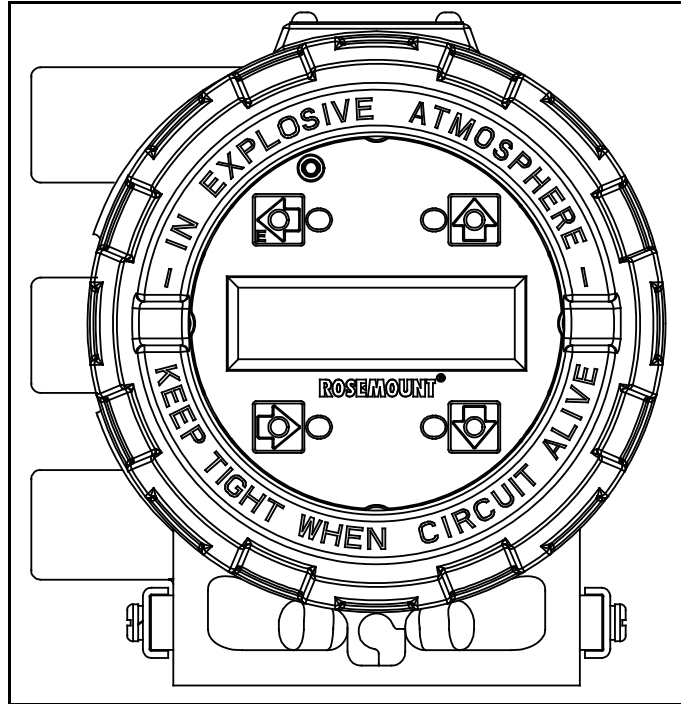

Data Entry

The LOI keypad does not have numerical keys. Numerical data is entered by the following procedure.

1. Access the appropriate function.
2. Use the **RIGHT ARROW** key to move to the value to change.
3. Use the **UP** and **DOWN ARROWS** to change the highlighted value. For numerical data, toggle through the digits **0–9**, **decimal point**, and **dash**. For alphabetical data, toggle through the letters of the alphabet **A–Z**, digits **0–9**, and the symbols **●, &, +, -, *, /, \$, @, %**, and the **blank space**.
4. Use the **RIGHT ARROWS** to highlight other digits you want to change and change them.
5. Press “**E**” (the left arrow key) when all changes are complete to save the entered values.

LOI EXAMPLES

Use the **DOWN ARROW** to access the menu structure in Figure 3-4 and Figure 3-5. Use the **ARROW KEYS** to select the desired parameters to review/change. Parameters are set in one of two ways, Table Values or Select Values.

Table Values:

Parameters such as units, that are available from a predefined list.

Select Values:

Parameters that consist of a user-created number or character string, such as calibration number; values are entered one character at a time using the **ARROW KEYS**.

Table Value Example

Setting the TUBE SIZE:

1. Press the **DOWN** arrow to access the menu.
2. Select line size from the Basic Setup menu.
3. Press the **UP** or **DOWN** arrow to increase/decrease (incrementally) the tube size to the next value.
4. When you reach the desired size, press “**E**” (the left arrow).
5. Set the loop to manual if necessary, and press “**E**” again.

After a moment, the LCD will display the new tube size and the maximum flow rate.

Select Value Example

Changing the ANALOG OUTPUT RANGE:

1. Press the **DOWN** arrow to access the menu.
2. Using the arrow keys, select PV URV from the Basic Setup menu.
3. Press **RIGHT** arrow key to position the cursor.
4. Press **UP** or **DOWN** to set the number.
5. Repeat steps 2 and 3 until desired number is displayed.
6. Press “**E**”.

After a moment, the LCD will display the new analog output range.

Display Lock

The display can be locked to prevent unintentional configuration changes. The display lock can be activated through a HART communication device, or by holding the UP arrow for approximately 10 seconds. When the display lock is activated, an image of a padlock will appear in the lower left hand corner of the display. To deactivate the display lock, hold the UP arrow for approximately 10 seconds. Once deactivated, the padlock will no longer appear in the lower left hand corner of the display.

Start Totalizer

To start the totalizer, press the **DOWN** arrow to display the totalizer screen and press “**E**” to begin totalization. A symbol $\bar{\ominus}$ will flash in the lower right hand corner indicating that the meter is totalizing.

Stop Totalizer

To stop the totalizer, press the **DOWN** arrow to display the totalizer screen and press “**E**” to end totalization. The flashing symbol $\bar{\ominus}$ will no longer display in the lower right hand corner indicating that the meter has stopped totalizing.

Reset Totalizer

To reset the totalizer, press the **DOWN** arrow to display the totalizer screen and follow the procedure above to stop totalization. Once totalization has stopped, press the **RIGHT** arrow key to reset the NET total value to zero.

To reset the GROSS, FORWARD, and REVERSE total values, you must change the line size. See “Line Size” on page 3-9 for details on how to change the line size.

Rosemount 8732

DIAGNOSTIC MESSAGES

The following error messages may appear on the LOI screen. See Table 6-1 on page 6-3 for potential causes and corrective actions for these errors:

- Electronics Failure
- Coil open circuit
- Digital trim failure
- Auto zero failure
- Auto trim failure
- Flowrate > sensor limit
- Analog out of range
- PZR activated
- Electronics Temp Fail
- Pulse out of range
- Empty pipe
- Reverse flow
- Electronics temp out of range

The following diagnostic messages may appear on the LOI screen. See Table 6-2 on page 6-4 for potential causes and corrective actions for these errors:

- High Process Noise
- Grounding/Wiring Fault
- Electrode Coating Limit 1
- Electrode Coating Limit 2

The following diagnostic messages may appear on the LOI screen. See Table 6-3 on page 6-5 for potential causes and corrective actions for these errors:

- 4-20 mA Loop Verification Failed
- 8714i Failed
- Continuous Meter Verification Error
- Internal Flow Simulator
- Coil Resistance Out of Spec
- Coil Signature Out of Spec
- Electrode Resistance Out of Spec
- Analog Output Out of Spec

Review

| | |
|-----------|------|
| Fast Keys | 1, 5 |
|-----------|------|

The 8732 includes a capability that enables you to review the configuration variable settings.

The flowmeter configuration parameters set at the factory should be reviewed to ensure accuracy and compatibility with your particular application of the flowmeter.

NOTE

If you are using the LOI to review variables, each variable must be accessed as if you were going to change its setting. The value displayed on the LOI screen is the configured value of the variable.

PROCESS VARIABLES

| | |
|-----------|------|
| Fast Keys | 1, 1 |
|-----------|------|

The *process variables* measure flow in several ways that reflect your needs and the configuration of your flowmeter. When commissioning a flowmeter, review each process variable, its function and output, and take corrective action if necessary before using the flowmeter in a process application

Primary Variable (PV) – The actual measured flow rate in the line. Use the Process Variable Units function to select the units for your application.

Percent of Range – The process variable as a percentage of the Analog Output range, provides an indication where the current flow of the meter is within the configured range of the flowmeter. For example, the Analog Output range may be defined as 0 gal/min to 20 gal/min. If the measured flow is 10 gal/min, the percent of range is 50 percent.

Analog Output – The analog output variable provides the analog value for the flow rate. The analog output refers to the industry standard output in the 4–20 mA range. The analog output and 4-20 mA loop can be verified using the Analog Feedback diagnostic capability internal to the transmitter (See “4-20 mA Loop Verification” on page C-9).

Totalizer Setup – Provides a reading of the total flow of the flowmeter since the totalizer was last reset. The totalizer value should be zero during commissioning on the bench, and the units should reflect the volume units of the flow rate. If the totalizer value is not zero, it may need to be reset. This function also allows for configuration of the totalizer parameters.

Pulse Output – The pulse output variable provides the pulse value for the flow rate.

PV - Primary Variable

| | |
|-----------|---------|
| Fast Keys | 1, 1, 1 |
|-----------|---------|

The *Primary Variable* shows the current measured flow rate. This value determines the analog output from the transmitter.

PV -% Range

| | |
|-----------|---------|
| Fast Keys | 1, 1, 2 |
|-----------|---------|

The *PV% Range* shows where in the flow range the current flow value is as a percentage of the configured span.

PV - Analog Output

| | |
|-----------|---------|
| Fast Keys | 1, 1, 3 |
|-----------|---------|

The *PV Analog Output* displays the mA output of the transmitter corresponding to the measured flow rate.

Totalizer Setup

| | |
|-----------|---------|
| Fast Keys | 1, 1, 4 |
|-----------|---------|

The *Totalizer Setup* menu allows for the viewing and configuration of the totalizer parameters.

Totalizer Units

| | |
|-----------|------------|
| Fast Keys | 1, 1, 4, 1 |
|-----------|------------|

Totalizer units allow for the configuration of the units that the totalized value will be displayed as. These units are independent of the flow units.

Measured Gross Total

| | |
|-----------|------------|
| Fast Keys | 1, 1, 4, 2 |
|-----------|------------|

Measured gross total provides the output reading of the totalizer. This value is the amount of process fluid that has passed through the flowmeter since the totalizer was last reset.

NOTE

To reset the measured gross total value, the line size must be changed.

Measured Net Total

| | |
|-----------|------------|
| Fast Keys | 1, 1, 4, 3 |
|-----------|------------|

Measured net total provides the output reading of the totalizer. This value is the amount of process fluid that has passed through the flowmeter since the totalizer was last reset. When reverse flow is enabled, the net total represents the difference between the total flow in the forward direction less the total flow in the reverse direction.

Reverse Total

| | |
|-----------|------------|
| Fast Keys | 1, 1, 4, 4 |
|-----------|------------|

Reverse total provides the measured output reading of the totalizer. This value is the amount of process fluid that has passed through the flowmeter in the reverse direction since the totalizer was last reset. This value is only totalized when reverse flow is enabled.

Start Totalizer

| | |
|-----------|------------|
| Fast Keys | 1, 1, 4, 5 |
|-----------|------------|

Start totalizer starts the totalizer counting from its current value.

Stop Totalizer

| | |
|-----------|------------|
| Fast Keys | 1, 1, 4, 6 |
|-----------|------------|

Stop totalizer interrupts the totalizer count until it is restarted again. This feature is often used during pipe cleaning or other maintenance operations.

Reset Totalizer

| | |
|-----------|------------|
| Fast Keys | 1, 1, 4, 7 |
|-----------|------------|

Reset totalizer resets the net totalizer value to zero. The totalizer must be stopped before resetting.

NOTE

The totalizer value is saved in the Non-Volatile memory of the electronics every three seconds. Should power to the transmitter be interrupted, the totalizer value will start at the last saved value when power is re-applied.

Pulse Output

| | |
|-----------|---------|
| Fast Keys | 1, 1, 5 |
|-----------|---------|

The *Pulse Output* displays the current value of the pulse signal.

BASIC SETUP

| | |
|-----------|------|
| Fast Keys | 1, 3 |
|-----------|------|

The basic configuration functions of the Rosemount 8732 must be set for all applications of the transmitter in a magnetic flowmeter system. If your application requires the advanced functionality features of the Rosemount 8732, see Section 4 "Operation" of this manual.

Tag

| | |
|-----------|---------|
| Fast Keys | 1, 3, 1 |
|-----------|---------|

Tag is the quickest and shortest way of identifying and distinguishing between transmitters. Transmitters can be tagged according to the requirements of your application. The tag may be up to eight characters long.

Flow Units

| | |
|-----------|---------|
| Fast Keys | 1, 3, 2 |
|-----------|---------|

Flow Units set the output units for the Primary Variable (PV) which controls the analog output of the transmitter.

Primary Variable (PV) Units

| | |
|-----------|------------|
| Fast Keys | 1, 3, 2, 1 |
|-----------|------------|

The *PV Units* specifies the format in which the flow rate will be displayed. Units should be selected to meet your particular metering needs.

Options for Flow Rate Units

- ft/sec
- m/sec
- gal/sec
- gal/min
- gal/hr
- gal/day
- l/sec
- l/min
- l/hr
- l/day
- ft³/sec
- ft³/min
- ft³/hr
- cm³/min
- m³/sec
- m³/min
- m³/hr
- m³/day
- Impgal/sec
- Impgal/min
- Impgal/hr
- Impgal/day
- B42/sec (1 Barrel = 42 gallons)
- B42/min (1 Barrel = 42 gallons)
- B42/hr (1 Barrel = 42 gallons)
- B42/day (1 Barrel = 42 gallons)
- B31/sec (1 Barrel = 31 gallons)
- B31/min (1 Barrel = 31 gallons)
- B31/hr (1 Barrel = 31 gallons)
- B31/day (1 Barrel = 31 gallons)
- lbs/sec
- lbs/min
- lbs/hr
- lbs/day
- kg/sec
- kg/min
- kg/hr
- kg/day
- (s)tons/min
- (s)tons/hr
- (s)tons/day
- (m)tons/min
- (m)tons/hr
- (m)tons/day
- Special (User Defined, see "Special Units" on page 3-7)

Special Units

| | |
|-----------|------------|
| Fast Keys | 1, 3, 2, 2 |
|-----------|------------|

The Rosemount 8732 provides a selection of standard unit configurations that meet the needs of most applications (see "Flow Units" on page 3-6). If your application has special needs and the standard configurations do not apply, the Rosemount 8732 provides the flexibility to configure the transmitter in a custom-designed units format using the *special units* variable.

Volume Unit

| | |
|------------------|----------------------|
| Fast Keys | 1, 3, 2, 2, 1 |
|------------------|----------------------|

Volume unit enables you to display the volume unit format to which you have converted the base volume units. For example, if the special units are abc/min, the special volume variable is abc. The volume units variable is also used in totalizing the special units flow.

Base Volume Unit

| | |
|------------------|----------------------|
| Fast Keys | 1, 3, 2, 2, 2 |
|------------------|----------------------|

Base volume unit is the unit from which the conversion is being made. Set this variable to the appropriate option.

Conversion Number

| | |
|------------------|----------------------|
| Fast Keys | 1, 3, 2, 2, 3 |
|------------------|----------------------|

The special units *conversion number* is used to convert base units to special units. For a straight conversion of volume units from one to another, the conversion number is the number of base units in the new unit. For example, if you are converting from gallons to barrels and there are 31 gallons in a barrel, the conversion factor is 31.

Base Time Unit

| | |
|------------------|----------------------|
| Fast Keys | 1, 3, 2, 2, 4 |
|------------------|----------------------|

Base time unit provides the time unit from which to calculate the special units. For example, if your special units is a volume per minute, select minutes.

Flow Rate Unit

| | |
|------------------|----------------------|
| Fast Keys | 1, 3, 2, 2, 5 |
|------------------|----------------------|

Flow rate unit is a format variable that provides a record of the units to which you are converting. The Handheld Communicator will display a special units designator as the units format for your primary variable. The actual special units setting you define will not appear. Four characters are available to store the new units designation. The 8732 LOI will display the four character designation as configured.

Example

To display flow in acre-feet per day, and acre-foot is equal to 43560 cubic feet, the procedure would be:

- Set the Volume Unit to **ACFT**.
- Set the Base Volume Unit to **ft³**.
- Set the Input Conversion Number to **43560**.
- Set the Time Base to **Day**.
- Set the Rate Unit to **AF/D**.

Line Size

| | |
|-----------|---------|
| Fast Keys | 1, 3, 3 |
|-----------|---------|

The *line size* (sensor size) must be set to match the actual sensor connected to the transmitter. The size must be specified in inches according to the available sizes listed below. If a value is entered from a control system or Handheld Communicator that does not match one of these figures, the value will go to the next highest option.

The line size (inches) options are as follows:

| |
|--|
| 0.1, 0.15, 0.25, 0.30, 0.50, 0.75, 1, 1.5, 2, 2.5, 3, 4, 5, 6, 8, 10, 12, 14, 16, 18, 20, 24, 28, 30, 32, 36, 40, 42, 44, 48, 54, 56, 60, 64, 66, 72, 78, 80 |
|--|

**PV URV
(Upper Range Value)**

| | |
|-----------|---------|
| Fast Keys | 1, 3, 4 |
|-----------|---------|

The *upper range value* (URV), or analog output range, is preset to 30 ft/s at the factory. The units that appear will be the same as those selected under the units parameter.

The URV (20 mA point) can be set for both forward or reverse flow rate. Flow in the forward direction is represented by positive values and flow in the reverse direction is represented by negative values. The URV can be any value from -39.3 ft/s to +39.3 ft/s (-12 m/s to +12 m/s), as long as it is at least 1 ft/s (0.3 m/s) from the lower range value (4 mA point). The URV can be set to a value less than the lower range value. This will cause the transmitter analog output to operate in reverse, with the current increasing for lower (or more negative) flow rates.

NOTE

Line size, special units, and density must be selected prior to configuration of URV and LRV.

**PV LRV
(Lower Range Value)**

| | |
|-----------|---------|
| Fast Keys | 1, 3, 5 |
|-----------|---------|

The *lower range value* (LRV), or analog output zero, is preset to 0 ft/s at the factory which is common for most applications. The units that appear will be the same as those selected under the units parameter. It can be used to change the size of the range (or span) between the URV and LRV. Under normal circumstances, the LRV should be set to a value near the minimum expected flow rate to maximize resolution. The LRV must be between -39.3 ft/s to +39.3 ft/s (-12 m/s to +12 m/s).

NOTE

Line size, special units, and density must be selected prior to configuration of URV and LRV.

Example

If the URV is greater than the LRV, the analog output will saturate at 3.9 mA when the flow rate falls below the selected 4 mA point.

The minimum allowable span between the URV and LRV is 1 ft/s (0.3 m/s). Do not set the LRV within 1 ft/s (0.3 m/s) of the 20 mA point. For example, if the URV is set to 15.67 ft/s (4.8 m/s) and if the desired URV is greater than the LRV, then the highest allowable analog zero setting would be 14.67 ft/s (4.5 m/s). If the desired URV is less than the LRV, then the lowest allowable LRV would be 16.67 ft/s (5.1 m/s).

Table 3-2. Field Communicator
Fast Keys

| Function | Fast Keys |
|--------------------------|-------------------------------|
| Process Variables | 1, 1 |
| Primary Variable (PV) | 1, 1, 1 |
| PV Percent of Range | 1, 1, 2 |
| PV Analog Output (AO) | 1, 1, 3 |
| Totalizer Set-Up | 1, 1, 4 |
| Totalizer Units | 1, 1, 4, 1 |
| Gross Total | 1, 1, 4, 2 |
| Net Total | 1, 1, 4, 3 |
| Reverse Total | 1, 1, 4, 4 |
| Start Totalizer | 1, 1, 4, 5 |
| Stop Totalizer | 1, 1, 4, 6 |
| Reset Totalizer | 1, 1, 4, 7 |
| Pulse Output | 1, 1, 5 |
| | |
| Diagnostics | 1, 2 |
| Diag Controls | 1, 2, 1 |
| Diagnostic Controls | 1, 2, 1, 1 |
| Empty Pipe | 1, 2, 1, 1, -- ⁽¹⁾ |
| Process Noise | 1, 2, 1, 1, -- ⁽¹⁾ |
| Grounding/Wiring | 1, 2, 1, 1, -- ⁽¹⁾ |
| Electrode Coating | 1, 2, 1, 1, -- ⁽¹⁾ |
| Electronics Temp | 1, 2, 1, 1, -- ⁽¹⁾ |
| Reverse Flow | 1, 2, 1, 2 |
| Continual Ver. | 1, 2, 1, 3 |
| Coils | 1, 2, 1, 3, 1 |
| Electrodes | 1, 2, 1, 3, 2 |
| Transmitter | 1, 2, 1, 3, 3 |
| Analog Output | 1, 2, 1, 3, 4 |
| Basic Diagnostics | 1, 2, 2 |
| Self Test | 1, 2, 2, 1 |
| AO Loop Test | 1, 2, 2, 2 |
| 4 mA | 1, 2, 2, 2, 1 |
| 20 mA | 1, 2, 2, 2, 2 |
| Simulate Alarm | 1, 2, 2, 2, 3 |
| Other End | 1, 2, 2, 2, 4 |
| Electronics Temp | 1, 2, 2, 2, 5 |
| Pulse Output Loop Test | 1, 2, 2, 3 |
| Tune Empty Pipe | 1, 2, 2, 4 |
| EP Value | 1, 2, 2, 4, 1 |
| EP Trig. Level | 1, 2, 2, 4, 2 |
| EP Counts | 1, 2, 2, 4, 3 |
| Electronics Temp | 1, 2, 2, 5 |
| Flow Limit 1 | 1, 2, 2, 6 |
| Control 1 | 1, 2, 2, 6, 1 |
| Mode 1 | 1, 2, 2, 6, 2 |
| High Limit 1 | 1, 2, 2, 6, 3 |
| Low Limit 1 | 1, 2, 2, 6, 4 |
| Flow Limit Hysteresis | 1, 2, 2, 6, 5 |
| Flow Limit 2 | 1, 2, 2, 7 |
| Control 2 | 1, 2, 2, 7, 1 |
| Mode 2 | 1, 2, 2, 7, 2 |
| High Limit 2 | 1, 2, 2, 7, 3 |
| Low Limit 2 | 1, 2, 2, 7, 4 |
| Flow Limit Hysteresis | 1, 2, 2, 7, 5 |
| Total Limit | 1, 2, 2, 7, 5 |

(1) These items are in a list format without numeric labels.

(2) To access these features, you must scroll to this option in the HART Field communicator.

| Function | Fast Keys |
|--|-------------------------------------|
| Total Control | 1, 2, 2, 8, 1 |
| Total Mode | 1, 2, 2, 8, 2 |
| Total High Limit | 1, 2, 2, 8, 3 |
| Total Low Limit | 1, 2, 2, 8, 4 |
| Total Limit Hysteresis | 1, 2, 2, 8, 5 |
| Advanced Diagnostics | 1, 2, 3 |
| Electrode Coat | 1, 2, 3, 1 |
| EC Value | 1, 2, 3, 1, 1 |
| EC Level 1 Limit | 1, 2, 3, 1, 2 |
| EC Level 2 Limit | 1, 2, 3, 1, 3 |
| Max EC Value | 1, 2, 3, 1, 4 |
| Clear Max Electrode | 1, 2, 3, 1, 5 |
| 8714i Cal Verification | 1, 2, 3, 2 |
| Run 8714i Cal Verification | 1, 2, 3, 2, 1 |
| View Results | 1, 2, 3, 2, 2 |
| Manual Results | 1, 2, 3, 2, 2, 1 |
| Test Condition | 1, 2, 3, 2, 2, 1, 1 |
| Test Criteria | 1, 2, 3, 2, 2, 1, 2 |
| 8714i Test Result | 1, 2, 3, 2, 2, 1, 3 |
| Simulated Velocity | 1, 2, 3, 2, 2, 1, 4 |
| Actual Velocity | 1, 2, 3, 2, 2, 1, 5 |
| Velocity Deviation | 1, 2, 3, 2, 2, 1, 6 |
| Xmter Cal Test Result | 1, 2, 3, 2, 2, 1, 7 |
| Sensor Cal Deviation | 1, 2, 3, 2, 2, 1, 8 |
| Sensor Cal Test Result | 1, 2, 3, 2, 2, 1, 9 |
| Coil Circuit Test Result ⁽²⁾ | 1, 2, 3, 2, 2, 1, 10 ⁽²⁾ |
| Electrode Circuit Test Result ⁽²⁾ | 1, 2, 3, 2, 2, 1, 11 ⁽²⁾ |
| Continual Results | 1, 2, 3, 2, 2, 2 |
| Continuous Limit | 1, 2, 3, 2, 2, 2, 1 |
| Simulated Velocity | 1, 2, 3, 2, 2, 2, 2 |
| Actual Velocity | 1, 2, 3, 2, 2, 2, 3 |
| Velocity Deviation | 1, 2, 3, 2, 2, 2, 4 |
| Coil Signature | 1, 2, 3, 2, 2, 2, 5 |
| Sensor Cal Deviation | 1, 2, 3, 2, 2, 2, 6 |
| Coil Resistance | 1, 2, 3, 2, 2, 2, 7 |
| Electrode Resistance | 1, 2, 3, 2, 2, 2, 8 |
| mA Expected | 1, 2, 3, 2, 2, 2, 9 |
| mA Actual ⁽²⁾ | 1, 2, 3, 2, 2, 2, 10 ⁽²⁾ |
| mA Deviation ⁽²⁾ | 1, 2, 3, 2, 2, 2, 11 ⁽²⁾ |
| Sensor Signature | 1, 2, 3, 2, 3 |
| Signature Values | 1, 2, 3, 2, 3, 1 |
| Coil Resistance | 1, 2, 3, 2, 3, 1, 1 |
| Coil Signature | 1, 2, 3, 2, 3, 1, 2 |
| Electrode Resistance | 1, 2, 3, 2, 3, 1, 3 |
| Re-Signature Meter | 1, 2, 3, 2, 3, 2 |
| Recall Last Saved Values | 1, 2, 3, 2, 3, 3 |
| Set Pass/Fail Criteria | 1, 2, 3, 2, 4 |
| No Flow Limit | 1, 2, 3, 2, 4, 1 |
| Flowing Limit | 1, 2, 3, 2, 4, 2 |
| Empty Pipe Limit | 1, 2, 3, 2, 4, 3 |
| Continuous Limit | 1, 2, 3, 2, 4, 4 |
| Measurements | 1, 2, 3, 2, 5 |
| Manual Measurements | 1, 2, 3, 2, 5, 1 |
| Coil Resistance | 1, 2, 3, 2, 5, 1, 1 |
| Coil Signature | 1, 2, 3, 2, 5, 1, 2 |
| Electrode Resistance | 1, 2, 3, 2, 5, 1, 3 |

(1) These items are in a list format without numeric labels.

(2) To access these features, you must scroll to this option in the HART Field communicator.

| Function | Fast Keys |
|-------------------------------|----------------------------------|
| Continual Measurements | 1, 2, 3, 2, 5, 2 |
| Coil Resistance | 1, 2, 3, 2, 5, 2, 1 |
| Coil Signature | 1, 2, 3, 2, 5, 2, 2 |
| Electrode Resistance | 1, 2, 3, 2, 5, 2, 3 |
| Actual Velocity | 1, 2, 3, 2, 5, 2, 4 |
| mA Expected | 1, 2, 3, 2, 5, 2, 5 |
| mA Actual | 1, 2, 3, 2, 5, 2, 6 |
| 4-20 mA Verify | 1, 2, 3, 3, |
| 4-20 mA Verification | 1, 2, 3, 3, 1 |
| View Results | 1, 2, 3, 3, 2 |
| Licensing | 1, 2, 3, 4 |
| License Status | 1, 2, 3, 4, 1 |
| Process Noise Detect | 1, 2, 3, 4, 1, 1 |
| Line Noise Detection | 1, 2, 3, 4, 1, 2 |
| Electrode Coating | 1, 2, 3, 4, 1, 3 |
| 8714i | 1, 2, 3, 4, 1, 4 |
| Digital I/O | 1, 2, 3, 4, 1, 5 |
| License Key | 1, 2, 3, 4, 2 |
| Device ID | 1, 2, 3, 4, 2, 1 |
| License Key | 1, 2, 3, 4, 2, 2 |
| Diagnostic Variables | 1, 2, 4 |
| EP Value | 1, 2, 4, 1 |
| Electronics Temp | 1, 2, 4, 2 |
| Line Noise | 1, 2, 4, 3 |
| 5 Hz SNR | 1, 2, 4, 4 |
| 37 Hz SNR | 1, 2, 4, 5 |
| Electrode Coat | 1, 2, 4, 6 |
| EC Value | 1, 2, 4, 6, 1 |
| Max EC Value | 1, 2, 4, 6, 2 |
| Sig Power | 1, 2, 4, 7 |
| 8714i Results | 1, 2, 4, 8 |
| Manual Results | 1, 2, 4, 8, 1 |
| Test Condition | 1, 2, 4, 8, 1, 1 |
| Test Criteria | 1, 2, 4, 8, 1, 2 |
| 8714i Test Result | 1, 2, 4, 8, 1, 3 |
| Simulated Velocity | 1, 2, 4, 8, 1, 4 |
| Actual Velocity | 1, 2, 4, 8, 1, 5 |
| Velocity Deviation | 1, 2, 4, 8, 1, 6 |
| Xmter Cal Test Result | 1, 2, 4, 8, 1, 7 |
| Sensor Cal Deviation | 1, 2, 4, 8, 1, 8 |
| Sensor Cal Test Result | 1, 2, 4, 8, 1, 9 |
| Coil Circuit Test Result | 1, 2, 4, 8, 1, 10 ⁽²⁾ |
| Electrode Circuit Test Result | 1, 2, 4, 8, 1, 11 ⁽²⁾ |
| Continual Results | 1, 2, 4, 8, 2 |
| Continuous Limit | 1, 2, 4, 8, 2, 1 |
| Simulated Velocity | 1, 2, 4, 8, 2, 2 |
| Actual Velocity | 1, 2, 4, 8, 2, 3 |
| Velocity Deviation | 1, 2, 4, 8, 2, 4 |
| Coil Signature | 1, 2, 4, 8, 2, 5 |
| Sensor Cal Deviation | 1, 2, 4, 8, 2, 6 |
| Coil Resistance | 1, 2, 4, 8, 2, 7 |
| Electrode Resistance | 1, 2, 4, 8, 2, 8 |
| mA Expected | 1, 2, 4, 8, 2, 9 |
| mA Actual | 1, 2, 4, 8, 2, 10 ⁽²⁾ |
| mA Deviation | 1, 2, 4, 8, 2, 11 ⁽²⁾ |
| Trims | 1, 2, 5 |

(1) These items are in a list format without numeric labels.

(2) To access these features, you must scroll to this option in the HART Field communicator.

| Function | Fast Keys |
|--------------------------|----------------------------------|
| D/A Trim | 1, 2, 5, 1 |
| Scaled D/A Trim | 1, 2, 5, 2 |
| Digital Trim | 1, 2, 5, 3 |
| Auto Zero | 1, 2, 5, 4 |
| Universal Trim | 1, 2, 5, 5 |
| View Status | 1, 2, 5, 6 |
| | |
| Basic Setup | 1, 3 |
| Tag | 1, 3, 1 |
| Flow Units | 1, 3, 2 |
| PV Units | 1, 3, 2, 1 |
| Special Units | 1, 3, 2, 2 |
| Volume Unit | 1, 3, 2, 2, 1 |
| Base Volume Unit | 1, 3, 2, 2, 2 |
| Conversion Number | 1, 3, 2, 2, 3 |
| Base Time Unit | 1, 3, 2, 2, 4 |
| Flow Rate Unit | 1, 3, 2, 2, 5 |
| Line Size | 1, 3, 3 |
| PV URV | 1, 3, 4 |
| PV LRV | 1, 3, 5 |
| Calibration Number | 1, 3, 6 |
| PV Damping | 1, 3, 7 |
| | |
| Detailed Setup | 1, 4 |
| Additional Parameters | 1, 4, 1 |
| Coil Drive Frequency | 1, 4, 1, 1 |
| Density Value | 1, 4, 1, 2 |
| PV USL | 1, 4, 1, 3 |
| PV LSL | 1, 4, 1, 4 |
| PV Minimum Span | 1, 4, 1, 5 |
| Configure Output | 1, 4, 2 |
| Analog Output | 1, 4, 2, 1 |
| PV URV | 1, 4, 2, 1, 1 |
| PV LRV | 1, 4, 2, 1, 2 |
| PV AO | 1, 4, 2, 1, 3 |
| AO Alarm Type | 1, 4, 2, 1, 4 |
| AO Loop Test | 1, 4, 2, 1, 5 |
| D/A Trim | 1, 4, 2, 1, 6 |
| Scaled D/A Trim | 1, 4, 2, 1, 7 |
| Alarm Level | 1, 4, 2, 1, 8 |
| AO Diag Alarm | 1, 4, 2, 1, 9 |
| Empty Pipe | 1, 4, 2, 1, 9, 1 |
| Reverse Flow | 1, 4, 2, 1, 9, 2 |
| Ground/Wiring Fault | 1, 4, 2, 1, 9, 3 |
| High Process Noise | 1, 4, 2, 1, 9, 4 |
| Elect Temp Out of Range | 1, 4, 2, 1, 9, 5 |
| Electrode Coat Limit 2 | 1, 4, 2, 1, 9, 6 |
| Totalizer Limit 1 | 1, 4, 2, 1, 9, 7 |
| Flow Limit 1 | 1, 4, 2, 1, 9, 8 |
| Flow Limit 2 | 1, 4, 2, 1, 9, 9 |
| Cont. Meter Verification | 1, 4, 2, 1, 9, 10 ⁽²⁾ |
| Pulse Output | 1, 4, 2, 2 |
| Pulse Scaling | 1, 4, 2, 2, 1 |
| Pulse Width | 1, 4, 2, 2, 2 |
| Pulse Mode | 1, 4, 2, 2, 3 |
| Pulse Out Loop Test | 1, 4, 2, 2, 4 |

(1) These items are in a list format without numeric labels.

(2) To access these features, you must scroll to this option in the HART Field communicator.

| Function | Fast Keys |
|--------------------------|----------------------------------|
| DI/DO Output | 1, 4, 2, 3 |
| DI/DO 1 | 1, 4, 2, 3, 1 |
| Configure I/O 1 | 1, 4, 2, 3, 1, 1 |
| Input | 1, 4, 2, 3, 1, 1, 1 |
| Output | 1, 4, 2, 3, 1, 1, 2 |
| Not Available/Off | 1, 4, 2, 3, 1, 1, 3 |
| DIO 1 Control | 1, 4, 2, 3, 1, 2 |
| Digital Input 1 | 1, 4, 2, 3, 1, 3 |
| Digital Output 1 | 1, 4, 2, 3, 1, 4 |
| DO 2 | 1, 4, 2, 3, 2 |
| Flow Limit 1 | 1, 4, 2, 3, 3 |
| Control 1 | 1, 4, 2, 3, 3, 1 |
| Mode 1 | 1, 4, 2, 3, 3, 2 |
| High Limit 1 | 1, 4, 2, 3, 3, 3 |
| Low Limit 1 | 1, 4, 2, 3, 3, 4 |
| Flow Limit Hysteresis | 1, 4, 2, 3, 3, 5 |
| Flow Limit 2 | 1, 4, 2, 3, 4 |
| Control 2 | 1, 4, 2, 3, 4, 1 |
| Mode 2 | 1, 4, 2, 3, 4, 2 |
| High Limit 2 | 1, 4, 2, 3, 4, 3 |
| Low Limit 2 | 1, 4, 2, 3, 4, 4 |
| Flow Limit Hysteresis | 1, 4, 2, 3, 4, 5 |
| Total Limit | 1, 4, 2, 3, 5 |
| Total Control | 1, 4, 2, 3, 5, 1 |
| Total Mode | 1, 4, 2, 3, 5, 2 |
| Total High Limit | 1, 4, 2, 3, 5, 3 |
| Total Low Limit | 1, 4, 2, 3, 5, 4 |
| Total Limit Hysteresis | 1, 4, 2, 3, 5, 5 |
| Diagnostic Status Alert | 1, 4, 2, 3, 6 |
| Electronics Failure | 1, 4, 2, 3, 6, -- ⁽¹⁾ |
| Coil Open Circuit | 1, 4, 2, 3, 6, -- ⁽¹⁾ |
| Empty Pipe | 1, 4, 2, 3, 6, -- ⁽¹⁾ |
| Reverse Flow | 1, 4, 2, 3, 6, -- ⁽¹⁾ |
| Ground/Wiring Fault | 1, 4, 2, 3, 6, -- ⁽¹⁾ |
| High Process Noise | 1, 4, 2, 3, 6, -- ⁽¹⁾ |
| Elect Temp Out of Range | 1, 4, 2, 3, 6, -- ⁽¹⁾ |
| Electrode Coat Limit 1 | 1, 4, 2, 3, 6, -- ⁽¹⁾ |
| Electrode Coat Limit 2 | 1, 4, 2, 3, 6, -- ⁽¹⁾ |
| Cont. Meter Verification | 1, 4, 2, 3, 6, -- ⁽¹⁾ |
| Reverse Flow | 1, 4, 2, 4 |
| Totalizer Setup | 1, 4, 2, 5 |
| Totalizer Units | 1, 4, 2, 5, 1 |
| Gross Total | 1, 4, 2, 5, 2 |
| Net Total | 1, 4, 2, 5, 3 |
| Reverse Total | 1, 4, 2, 5, 4 |
| Start Totalizer | 1, 4, 2, 5, 5 |
| Stop Totalizer | 1, 4, 2, 5, 6 |
| Reset Totalizer | 1, 4, 2, 5, 7 |
| Alarm level | 1, 4, 2, 6 |
| HART Output | 1, 4, 2, 7 |
| Variable Mapping | 1, 4, 2, 7, 1 |
| PV is | 1, 4, 2, 7, 1, 1 |
| SV is | 1, 4, 2, 7, 1, 2 |
| TV is | 1, 4, 2, 7, 1, 3 |
| QV is | 1, 4, 2, 7, 1, 4 |
| Poll Address | 1, 4, 2, 7, 2 |

(1) These items are in a list format without numeric labels.

(2) To access these features, you must scroll to this option in the HART Field communicator.

| Function | Fast Keys |
|------------------------|----------------------------------|
| Num Req Preams | 1, 4, 2, 7, 3 |
| Num Resp Preams | 1, 4, 2, 7, 4 |
| Burst Mode | 1, 4, 2, 7, 5 |
| Burst Option | 1, 4, 2, 7, 6 |
| PV | 1, 4, 2, 7, 6, -- ⁽¹⁾ |
| % Range/Current | 1, 4, 2, 7, 6, -- ⁽¹⁾ |
| Process Vars/Current | 1, 4, 2, 7, 6, -- ⁽¹⁾ |
| Dynamic Vars | 1, 4, 2, 7, 6, -- ⁽¹⁾ |
| LOI Config | 1, 4, 3 |
| Language | 1, 4, 3, 1 |
| Flowrate Display | 1, 4, 3, 2 |
| Totalizer Display | 1, 4, 3, 3 |
| Display Lock | 1, 4, 3, 4 |
| Signal Processing | 1, 4, 4 |
| Operating Mode | 1, 4, 4, 1 |
| Man Config DSP | 1, 4, 4, 2 |
| Status | 1, 4, 4, 2, 1 |
| Samples | 1, 4, 4, 2, 2 |
| % Limit | 1, 4, 4, 2, 3 |
| Time Limit | 1, 4, 4, 2, 4 |
| Coil Drive Freq | 1, 4, 4, 3 |
| Low Flow Cutoff | 1, 4, 4, 4 |
| PV Damping | 1, 4, 4, 5 |
| Universal Trim | 1, 4, 5 |
| Device Info | 1, 4, 6 |
| Manufacturer | 1, 4, 6, 1 |
| Tag | 1, 4, 6, 2 |
| Descriptor | 1, 4, 6, 3 |
| Message | 1, 4, 6, 4 |
| Date | 1, 4, 6, 5 |
| Device ID | 1, 4, 6, 6 |
| PV Sensor S/N | 1, 4, 6, 7 |
| Sensor Tag | 1, 4, 6, 8 |
| Write protect | 1, 4, 6, 9 |
| Revision No. | 1, 4, 6, 10 ⁽²⁾ |
| Universal Rev | 1, 4, 6, 10, -- ⁽¹⁾ |
| Transmitter Rev | 1, 4, 6, 10, -- ⁽¹⁾ |
| Software Rev | 1, 4, 6, 10, -- ⁽¹⁾ |
| Final Assembly # | 1, 4, 6, 10, -- ⁽¹⁾ |
| Construction Materials | 1, 4, 6, 11 ⁽²⁾ |
| Flange Type | 1, 4, 6, 11, -- ⁽¹⁾ |
| Flange Material | 1, 4, 6, 11, -- ⁽¹⁾ |
| Electrode Type | 1, 4, 6, 11, -- ⁽¹⁾ |
| Electrode Material | 1, 4, 6, 11, -- ⁽¹⁾ |
| Liner Material | 1, 4, 6, 11, -- ⁽¹⁾ |
| | |
| Review | 1, 5 |

(1) These items are in a list format without numeric labels.

(2) To access these features, you must scroll to this option in the HART Field communicator.

Figure 3-2. Field Communicator Menu Tree for the Rosemount 8732 - Device Setup

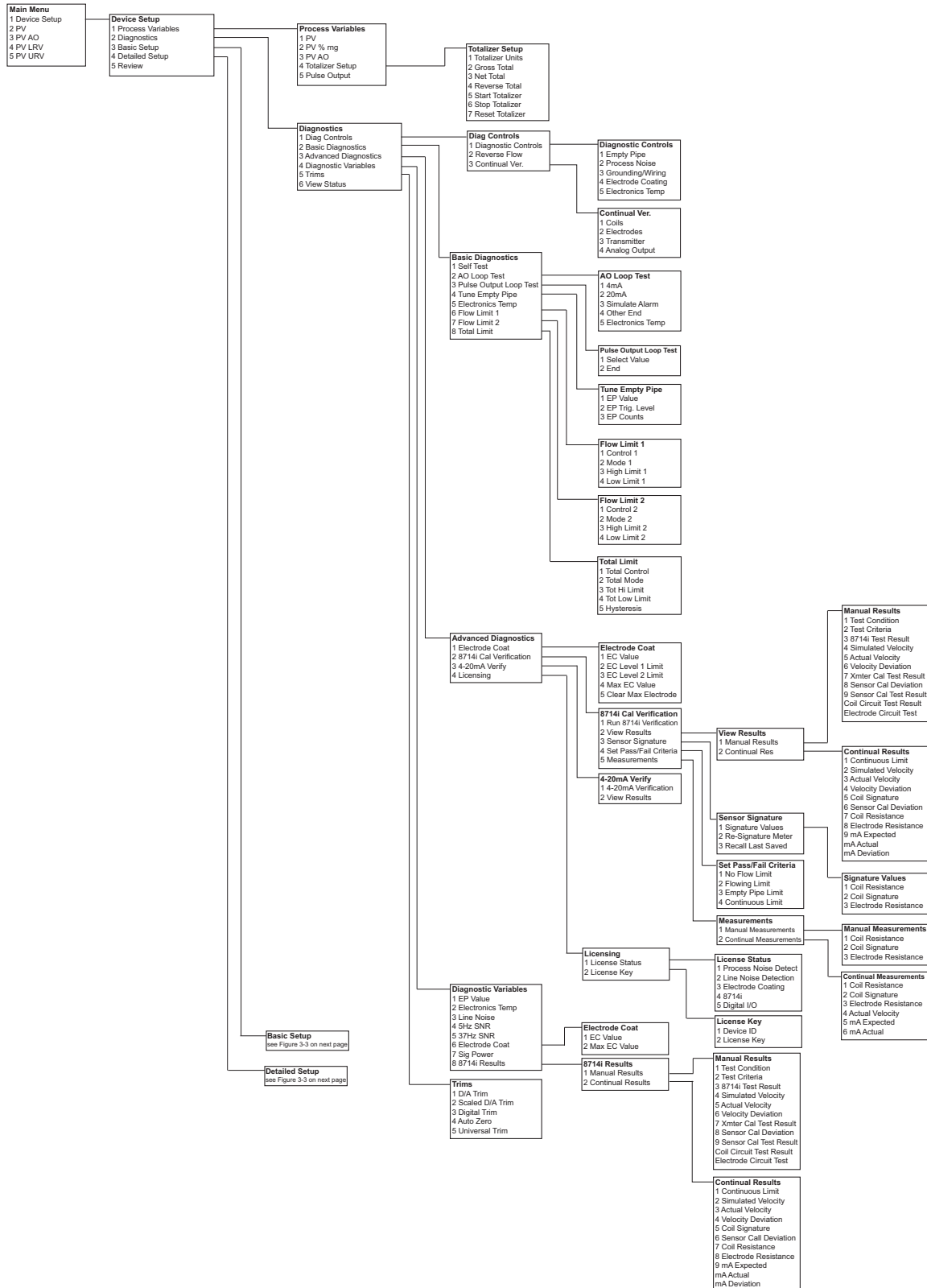

Figure 3-3. Field Communicator Menu Tree for the Rosemount 8732

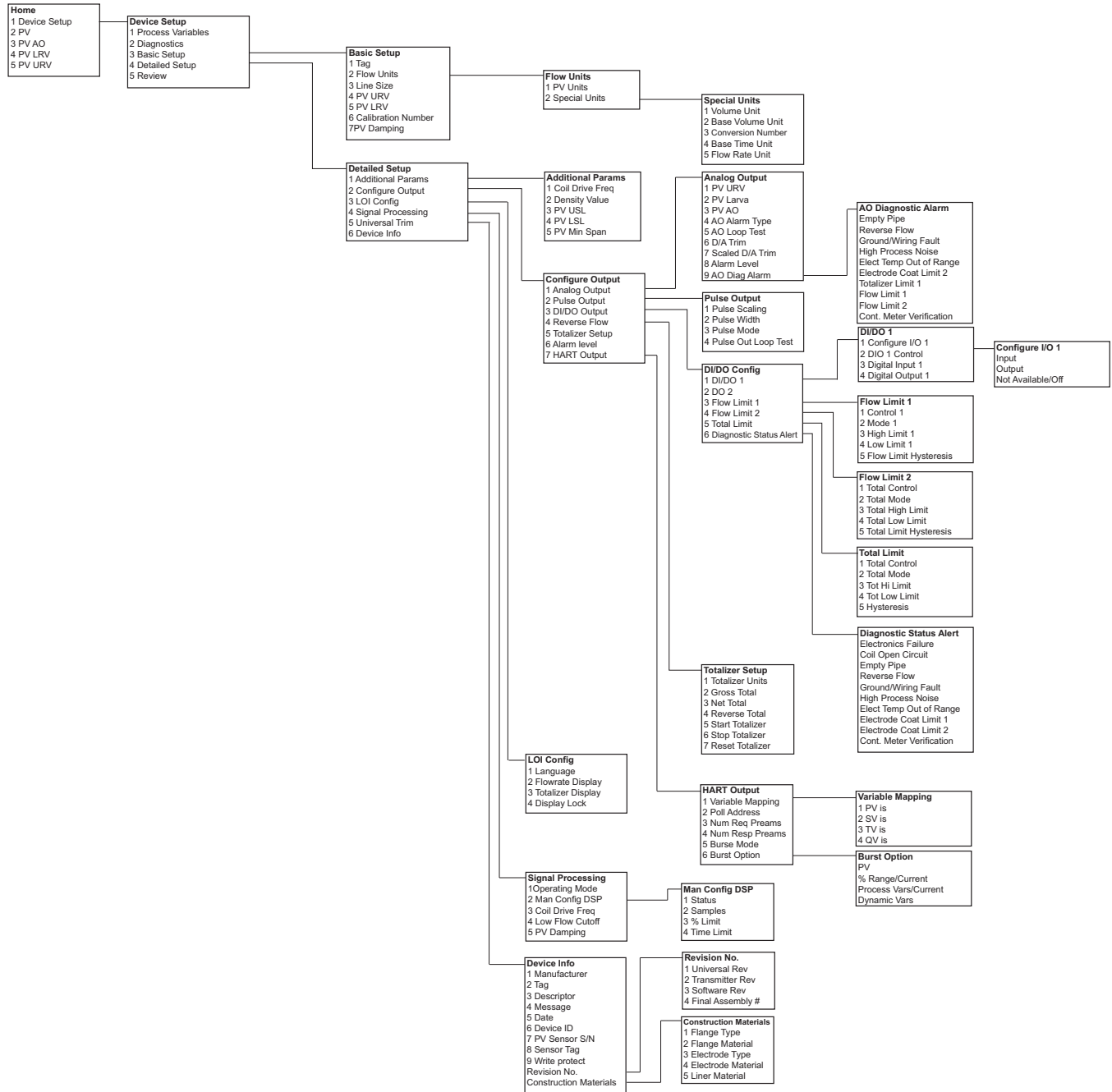

Figure 3-4. Local Operator Interface (LOI) Menu Tree for the Rosemount 8732 (Diagnostics and Basic Setup)

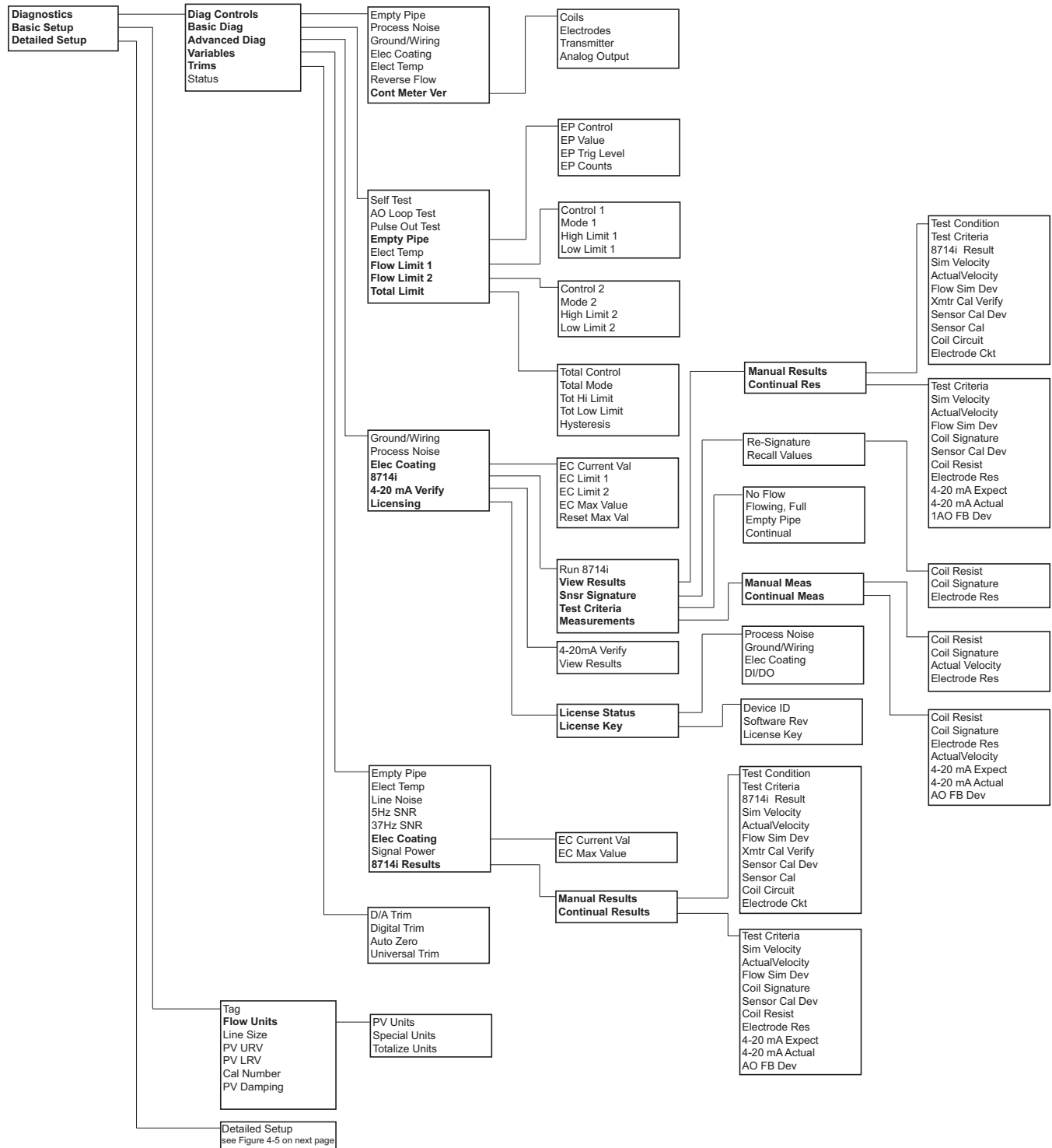
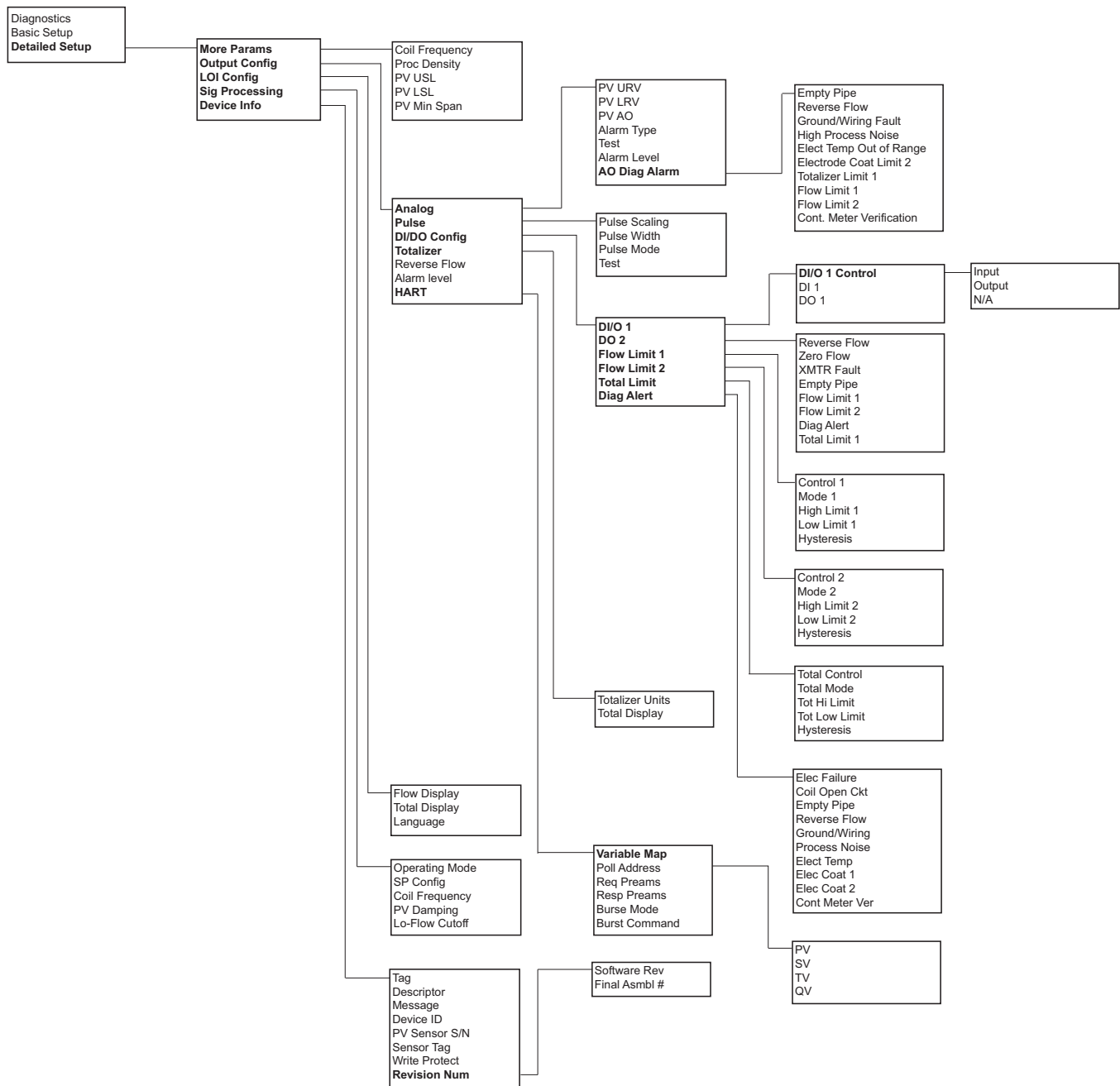

Figure 3-5. Local Operator Interface (LOI) Menu Tree for the Rosemount 8732 (Detailed Setup only)



Section 4 Operation

| | |
|-------------------------------------|------------------|
| Introduction | page 4-1 |
| Diagnostics | page 4-1 |
| Basic Diagnostics | page 4-3 |
| Advanced Diagnostics | page 4-5 |
| Advanced Configuration | page 4-11 |
| Detailed Setup | page 4-12 |

INTRODUCTION

This section contains information for advanced configuration parameters and diagnostics.

The software configuration settings for the Rosemount 8732 can be accessed through a HART-based communicator, Local Operator Interface (LOI), or through a control system. The software functions for the 475 Field Communicator are described in detail in this section of the manual. It provides an overview and summary of communicator functions. For more complete instructions, see the communicator manual. Before operating the Rosemount 8732 in an actual installation, you should review all of the factory set configuration data to ensure that they reflect the current application.

DIAGNOSTICS

| | |
|-----------|------|
| Fast Keys | 1, 2 |
|-----------|------|

Diagnostics are used to verify that the flowmeter is functioning properly, to assist in troubleshooting, to identify potential causes of error messages, and to verify the health of the transmitter and sensor. Diagnostic tests can be initiated through the use of a HART-based communications device, the Local Operator Interface, or through the control system.

Rosemount offers several different diagnostic suites providing various functionality.

Standard diagnostics included with every Rosemount 8732 transmitter are Empty Pipe detection, Electronics Temperature monitoring, Coil Fault detection, Reverse Flow detection, and various loop and transmitter tests.

Advanced diagnostics suite option one (DA1 option) contains advanced diagnostics for High Process Noise detection, Grounding and Wiring fault detection, and Coated Electrode detection.

Advanced diagnostics suite option two (DA2 option) contains advanced diagnostics for Smart Meter Verification (8714i) and 4-20 mA loop verification. These diagnostics are used to verify the accuracy and performance of the magnetic flowmeter installation.

Diagnostic Controls

| | |
|-----------|---------|
| Fast Keys | 1, 2, 1 |
|-----------|---------|

The diagnostic controls menu provides a centralized location for enabling or disabling each of the diagnostics that are available. Note that for some diagnostics to be available, a diagnostics suite package is required.

Empty Pipe

| | |
|-----------|-------------------------------|
| Fast Keys | 1, 2, 1, 1, -- ⁽¹⁾ |
|-----------|-------------------------------|

Turn the empty pipe diagnostic on or off as required by the application. For more details on the empty pipe diagnostic, see **Appendix C: "Diagnostics"**.

Process Noise

| | |
|-----------|-------------------------------|
| Fast Keys | 1, 2, 1, 1, -- ⁽¹⁾ |
|-----------|-------------------------------|

Turn the process noise diagnostic on or off as required by the application. For more details on the high process noise diagnostic, see **Appendix C: "Diagnostics"**.

Grounding / Wiring

| | |
|-----------|-------------------------------|
| Fast Keys | 1, 2, 1, 1, -- ⁽¹⁾ |
|-----------|-------------------------------|

Turn the grounding / wiring diagnostic on or off as required by the application. For more details on the grounding / wiring diagnostic, see **Appendix C: "Diagnostics"**.

Electrode Coating

| | |
|-----------|-------------------------------|
| Fast Keys | 1, 2, 1, 1, -- ⁽¹⁾ |
|-----------|-------------------------------|

Turn the electrode coating diagnostic on or off as required by the application. For more details on the electrode coating diagnostic, see **Appendix C: "Diagnostics"**.

Electronics Temp

| | |
|-----------|-------------------------------|
| Fast Keys | 1, 2, 1, 1, -- ⁽¹⁾ |
|-----------|-------------------------------|

Turn the electronics temperature diagnostic on or off as required by the application. For more details on the electronics temperature diagnostic, see **Appendix C: "Diagnostics"**.

Reverse Flow

| | |
|-----------|------------|
| Fast Keys | 1, 2, 1, 2 |
|-----------|------------|

Turn the reverse flow diagnostic on or off as required by the application. For more details on the reverse flow diagnostic, see **Appendix C: "Diagnostics"**.

Continual Verification

| | |
|-----------|------------|
| Fast Keys | 1, 2, 1, 3 |
|-----------|------------|

Turn the continuous smart meter verification diagnostic on or off as required by the application. For more details on the continuous smart meter verification diagnostic, see **Appendix C: "Diagnostics"**.

Coils

| | |
|-----------|---------------|
| Fast Keys | 1, 2, 1, 3, 1 |
|-----------|---------------|

Continuously monitor the sensor coil circuit by enabling this Continuous Smart Meter Verification parameter.

Electrodes

| | |
|-----------|---------------|
| Fast Keys | 1, 2, 1, 3, 2 |
|-----------|---------------|

Continuously monitor the electrode resistance by enabling this Continuous Smart Meter Verification parameter.

(1) These items are in a list format without numeric labels.

Transmitter

| | |
|-----------|---------------|
| Fast Keys | 1, 2, 1, 3, 3 |
|-----------|---------------|

Continuously monitor the transmitter calibration by enabling this Continuous Smart Meter Verification parameter.

Analog Output

| | |
|-----------|---------------|
| Fast Keys | 1, 2, 1, 3, 4 |
|-----------|---------------|

Continuously monitor the analog output signal by enabling this Continuous Smart Meter Verification parameter.

Basic Diagnostics

| | |
|-----------|---------|
| Fast Keys | 1, 2, 2 |
|-----------|---------|

The basic diagnostics menu contains all of the standard diagnostics and tests that are available in the 8732 transmitter.

Self Test

| | |
|-----------|------------|
| Fast Keys | 1, 2, 2, 1 |
|-----------|------------|

The transmitter test initiates a series of diagnostic tests that are not performed continuously during normal operation. It performs the following tests:

- Display Test
- RAM Test
- PROM Test

During the entire test, all outputs respond to flow signal. The test requires about ten seconds to complete.

AO Loop Test

| | |
|-----------|------------|
| Fast Keys | 1, 2, 2, 2 |
|-----------|------------|

The AO Loop test allows you to drive the transmitter output to a desired electrical current output on terminals 1 and 2. The user then has the ability to independently measure the actual loop current against the desired level set by the transmitter. On the LOI, the test will end after five minutes if the transmitter is not returned to normal operation manually.

4 mA

| | |
|-----------|---------------|
| Fast Keys | 1, 2, 2, 2, 1 |
|-----------|---------------|

Fix the analog loop current at 4 mA.

20 mA

| | |
|-----------|---------------|
| Fast Keys | 1, 2, 2, 2, 2 |
|-----------|---------------|

Fix the analog loop current at 20 mA.

Simulate Alarm

| | |
|-----------|---------------|
| Fast Keys | 1, 2, 2, 2, 3 |
|-----------|---------------|

Send the analog output into an alarm mA value. Actual mA value depends on the alarm configuration.

- Rosemount Standard High Alarm – 22.6 mA
- Rosemount Standard Low Alarm – 3.75 mA
- Namur Compliant High Alarm – 22.6 mA
- Namur Compliant Low Alarm – 3.5 mA

Other

| | |
|-----------|---------------|
| Fast Keys | 1, 2, 2, 2, 4 |
|-----------|---------------|

Fix the analog loop current to some other mA value between 3.5 mA and 23.0 mA.

End

| | |
|-----------|---------------|
| Fast Keys | 1, 2, 2, 2, 5 |
|-----------|---------------|

This command cancels the analog loop test and returns the analog output back into normal operating mode.

Pulse Output Loop Test

| | |
|-----------|------------|
| Fast Keys | 1, 2, 2, 3 |
|-----------|------------|

The Pulse Output Loop Test allows you to drive the frequency output at terminals 3 and 4 to a desired value. The user then has the ability to compare the pulse output value measured by auxiliary equipment to the desired pulse output level set by the transmitter. On the LOI the test will end after five minutes if the transmitter is not returned to normal operation manually.

Select Value

| | |
|-----------|---------------|
| Fast Keys | 1, 2, 2, 3, 1 |
|-----------|---------------|

Set the value of the pulse output for the test to a value between 1 pulse/day to 10,000 Hz.

End

| | |
|-----------|---------------|
| Fast Keys | 1, 2, 2, 3, 2 |
|-----------|---------------|

This command cancels the pulse output loop test and returns the pulse output back into normal operating mode.

Empty Pipe Limits

| | |
|-----------|------------|
| Fast Keys | 1, 2, 2, 4 |
|-----------|------------|

Empty Pipe allows you to view the current value and configure the diagnostic parameters. For more detail on this parameter see **Appendix C: "Diagnostics"**.

Empty Pipe Value

| | |
|-----------|---------------|
| Fast Keys | 1, 2, 2, 4, 1 |
|-----------|---------------|

Read the current Empty Pipe Value. This number is a unitless number and is calculated based on multiple installation and process variables. For more detail on this parameter see **Appendix C: "Diagnostics"**.

Empty Pipe Trigger Level

| | |
|-----------|---------------|
| Fast Keys | 1, 2, 2, 4, 2 |
|-----------|---------------|

Limits: 3 to 2000

Configure the threshold limit that the empty pipe value must exceed before the diagnostic alert activates. Default from the factory is set to 100. For more detail on this parameter see **Appendix C: "Diagnostics"**.

Empty Pipe Counts

| | |
|-----------|---------------|
| Fast Keys | 1, 2, 2, 4, 3 |
|-----------|---------------|

Limits: 5 to 50

Configure the number of consecutive times that the empty pipe value must exceed the empty pipe trigger level before the diagnostic alert activates. Counts are taken at 1.5 second intervals. Default from the factory is set to 5. For more detail on this parameter see **Appendix C: "Diagnostics"**.

Electronics Temperature

| | |
|-----------|------------|
| Fast Keys | 1, 2, 2, 5 |
|-----------|------------|

Electronics Temperature allows you to view the current value for the electronics temperature.

Advanced Diagnostics

| | |
|-----------|---------|
| Fast Keys | 1, 2, 3 |
|-----------|---------|

The advanced diagnostics menu contains information on all of the additional diagnostics and tests that are available in the 8732 transmitter if one of the diagnostics suite packages was ordered.

Rosemount offers two advanced diagnostic suites. Functionality under this menu will depend on which of these suites are ordered.

Advanced diagnostics suite option one (DA1 option) contains advanced diagnostics for High Process Noise detection, Grounding and Wiring fault detection, and Electrode Coating detection.

Advanced diagnostics suite option two (DA2 option) contains advanced diagnostics for the Smart Meter Verification (8714i) and 4-20 mA loop verification. These diagnostics are used to verify the accuracy and performance of the magnetic flowmeter installation. For more details on these diagnostics, see **Appendix C: "Diagnostics"**.

Diagnostic Variable Values

| | |
|-----------|---------|
| Fast Keys | 1, 2, 4 |
|-----------|---------|

From this menu, all of the diagnostic variable values can be reviewed. This information can be used to get more information about the transmitter, sensor, and process, or to get more detail about an alert that may have activated.

NOTE

A value of NAN (Not a Number) will be displayed for advanced diagnostics values that are not activated or for tests that have not been run.

Empty Pipe (EP) Value

| | |
|-----------|------------|
| Fast Keys | 1, 2, 4, 1 |
|-----------|------------|

Read the current value of the Empty Pipe parameter. This value will read zero if Empty Pipe is turned off.

Electronics Temperature

| | |
|-----------|------------|
| Fast Keys | 1, 2, 4, 2 |
|-----------|------------|

Read the current value of the Electronics Temperature.

Line Noise

| | |
|-----------|------------|
| Fast Keys | 1, 2, 4, 3 |
|-----------|------------|

Read the current value of the amplitude of AC line noise measured on the transmitter's electrode inputs. This value is used in the grounding / wiring diagnostic.

5 Hz Signal to Noise Ratio (SNR)

| | |
|-----------|------------|
| Fast Keys | 1, 2, 4, 4 |
|-----------|------------|

Read the current value of the signal to noise ratio when operating with the 5 Hz Coil Drive Frequency mode. For optimum performance, a value greater than 100 is preferred. Values less than 25 will cause the High Process Noise alert to activate.

37 Hz Signal to Noise Ratio (SNR)

| | |
|-----------|------------|
| Fast Keys | 1, 2, 4, 5 |
|-----------|------------|

Read the current value of the signal to noise ratio when operating with the 37.5 Hz Coil Drive Frequency mode. For optimum performance, a value greater than 100 is preferred. Values less than 25 will cause the High Process Noise alert to activate.

Electrode Coating

| | |
|-----------|------------|
| Fast Keys | 1, 2, 4, 6 |
|-----------|------------|

Electrode Coating allows you to view the current value and configure the diagnostic parameters for coded electrode detection. For more detail on this parameter see **Appendix C: "Diagnostics"**.

Electrode Coating (EC) Value

| | |
|-----------|---------------|
| Fast Keys | 1, 2, 4, 6, 1 |
|-----------|---------------|

Read the current Electrode Coating value. This number represents the level of the coating on the surface of the measurement electrodes. This value is compared to the Electrode Coating Limits to determine if a level 1 or level 2 coated electrode condition exists. If the Electrode Coating Value is larger than the Electrode Coating Limit, then the measurement electrodes are considered coated and the flow value may be inaccurate. For more details on this parameter, see **Appendix C: "Diagnostics"**.

Max Electrode Coating (EC) Value

| | |
|-----------|---------------|
| Fast Keys | 1, 2, 4, 6, 2 |
|-----------|---------------|

Read the maximum electrode coating value measured since this value was last reset. For more details on this parameter, see **Appendix C: "Diagnostics"**.

Signal Power

| | |
|-----------|------------|
| Fast Keys | 1, 2, 4, 7 |
|-----------|------------|

Read the current value of the calculated velocity of the fluid through the sensor. Higher velocities result in greater signal power.

8714i Results

| | |
|-----------|------------|
| Fast Keys | 1, 2, 4, 8 |
|-----------|------------|

Review the results of the Smart Meter Verification (8714i) tests. For more details on these results and what they mean, see **Appendix C: "Diagnostics"**.

Manual Results

| | |
|-----------|---------------|
| Fast Keys | 1, 2, 4, 8, 1 |
|-----------|---------------|

Review the results of the manually initially Smart Meter Verification (8714i) tests. For more details, see **Appendix C: "Diagnostics"**.

Test Condition

| | |
|-----------|------------------|
| Fast Keys | 1, 2, 4, 8, 1, 1 |
|-----------|------------------|

Displays the conditions that the Smart Meter Verification (8714i) test was performed under. For more details on this parameter see **Appendix C: "Diagnostics"**.

Test Criteria

| | |
|-----------|------------------|
| Fast Keys | 1, 2, 4, 8, 1, 2 |
|-----------|------------------|

Displays the criteria that the Smart Meter Verification (8714i) test was performed against. For more details on this parameter see **Appendix C: "Diagnostics"**.

8714i Test Result

| | |
|-----------|------------------|
| Fast Keys | 1, 2, 4, 8, 1, 3 |
|-----------|------------------|

Displays the results of the Smart Meter Verification (8714i) test as pass or fail. For more details on this parameter see **Appendix C: "Diagnostics"**.

Simulated Velocity

| | |
|-----------|------------------|
| Fast Keys | 1, 2, 4, 8, 1, 4 |
|-----------|------------------|

Displays the test velocity used to verify transmitter calibration. For more details on this parameter see **Appendix C: "Diagnostics"**.

Actual Velocity

| | |
|-----------|------------------|
| Fast Keys | 1, 2, 4, 8, 1, 5 |
|-----------|------------------|

Displays the velocity measured by the transmitter during the transmitter calibration verification test. For more details on this parameter see **Appendix C: "Diagnostics"**.

Velocity Deviation

| | |
|-----------|------------------|
| Fast Keys | 1, 2, 4, 8, 1, 6 |
|-----------|------------------|

Displays the deviation of the transmitter calibration verification test. For more details on this parameter see **Appendix C: "Diagnostics"**.

Transmitter Verification Test Result

| | |
|-----------|------------------|
| Fast Keys | 1, 2, 4, 8, 1, 7 |
|-----------|------------------|

Displays the result of the transmitter calibration verification test as pass or fail. For more details on this parameter see **Appendix C: "Diagnostics"**.

Sensor Verification Deviation

| | |
|-----------|------------------|
| Fast Keys | 1, 2, 4, 8, 1, 8 |
|-----------|------------------|

Displays the deviation of the sensor calibration verification test. For more details on this parameter see **Appendix C: "Diagnostics"**.

Sensor Verification Result

| | |
|-----------|------------------|
| Fast Keys | 1, 2, 4, 8, 1, 9 |
|-----------|------------------|

Displays the result of the sensor calibration verification test as pass or fail. For more details on this parameter see **Appendix C: "Diagnostics"**.

Coil Circuit Test Result

| | |
|-----------|----------------------------------|
| Fast Keys | 1, 2, 4, 8, 1, 10 ⁽¹⁾ |
|-----------|----------------------------------|

Displays the result of the coil circuit test as pass or fail. For more details on this parameter see **Appendix C: "Diagnostics"**.

Electrode Circuit Test Result

| | |
|-----------|----------------------------------|
| Fast Keys | 1, 2, 4, 8, 1, 11 ⁽¹⁾ |
|-----------|----------------------------------|

Displays the result of the electrode circuit test as pass or fail. For more details on this parameter see **Appendix C: "Diagnostics"**.

Continual Results

| | |
|-----------|---------------|
| Fast Keys | 1, 2, 4, 8, 2 |
|-----------|---------------|

Review the results of the Continuous Smart Meter Verification (8714i). For more details on these results and what they mean, see **Appendix C: "Diagnostics"**.

Continuous Limit

| | |
|-----------|------------------|
| Fast Keys | 1, 2, 4, 8, 2, 1 |
|-----------|------------------|

Displays the criteria that the Continuous Smart Meter Verification test is performed against. For more details on this parameter, see **Appendix C: "Diagnostics"**.

Simulated Velocity

| | |
|-----------|------------------|
| Fast Keys | 1, 2, 4, 8, 2, 2 |
|-----------|------------------|

Displays the test velocity used to verify transmitter calibration. For more details on this parameter see **Appendix C: "Diagnostics"**.

Actual Velocity

| | |
|-----------|------------------|
| Fast Keys | 1, 2, 4, 8, 2, 3 |
|-----------|------------------|

Displays the test velocity used to verify transmitter calibration. For more details, see **Appendix C: "Diagnostics"**.

Velocity Deviation

| | |
|-----------|------------------|
| Fast Keys | 1, 2, 4, 8, 2, 4 |
|-----------|------------------|

Displays the deviation of the transmitter calibration verification test. For more details, see **Appendix C: "Diagnostics"**.

Coil Signature

| | |
|-----------|------------------|
| Fast Keys | 1, 2, 4, 8, 2, 5 |
|-----------|------------------|

Displays the Coil Signature used to verify the magnetic field strength. For more details, see **Appendix C: "Diagnostics"**.

Sensor Cal Deviation

| | |
|-----------|------------------|
| Fast Keys | 1, 2, 4, 8, 2, 6 |
|-----------|------------------|

Displays the deviation in the sensor calibration. For more details, see **Appendix C: "Diagnostics"**.

Coil Resistance

| | |
|-----------|------------------|
| Fast Keys | 1, 2, 4, 8, 2, 7 |
|-----------|------------------|

Displays the Coil Resistance value used to verify the coil circuit health. For more details, see **Appendix C: "Diagnostics"**.

Electrode Resistance

| | |
|-----------|------------------|
| Fast Keys | 1, 2, 4, 8, 2, 8 |
|-----------|------------------|

Displays the Electrode Resistance value used to verify the electrode circuit health. For more details, see **Appendix C: "Diagnostics"**.

(1) To access these features, you must scroll to this option in the Field Communicator.

mA Expected

| | |
|-----------|------------------|
| Fast Keys | 1, 2, 4, 8, 2, 9 |
|-----------|------------------|

Review the results of the Continuous Smart Meter Verification (8714i). For more details, see **Appendix C: "Diagnostics"**.

mA Actual

| | |
|-----------|----------------------------------|
| Fast Keys | 1, 2, 4, 8, 2, 10 ⁽¹⁾ |
|-----------|----------------------------------|

Review the results of the Continuous Smart Meter Verification (8714i). For more details, see **Appendix C: "Diagnostics"**.

mA Deviation

| | |
|-----------|----------------------------------|
| Fast Keys | 1, 2, 4, 8, 2, 11 ⁽¹⁾ |
|-----------|----------------------------------|

Review the results of the Continuous Smart Meter Verification (8714i). For more details, see **Appendix C: "Diagnostics"**.

Trims

| | |
|-----------|---------|
| Fast Keys | 1, 2, 5 |
|-----------|---------|

Trims are used to calibrate the analog loop, calibrate the transmitter, re-zero the transmitter, and calibrate the transmitter with another manufacturer's sensor. Proceed with caution whenever performing a trim function.

D/A Trim

| | |
|-----------|------------|
| Fast Keys | 1, 2, 5, 1 |
|-----------|------------|

The D/A Trim is used to calibrate the 4-20 mA analog loop output from the transmitter. For maximum accuracy, the analog output should be trimmed for your system loop. Use the following steps to complete the Output Trim function.

1. Set the loop to manual, if necessary.
2. Connect a precision ammeter in the 4–20 mA loop.
3. Initiate the D/A Trim function with the LOI or Handheld Communicator.
4. Enter the 4 mA meter value when prompted to do so.
5. Enter the 20 mA meter value when prompted to do so.
6. Return the loop to automatic control, if necessary.

The 4–20 mA trim is now complete. You may repeat the 4–20 mA trim to check the results, or use the analog output test.

Scaled D/A Trim

| | |
|-----------|------------|
| Fast Keys | 1, 2, 5, 2 |
|-----------|------------|

Scaled D/A trim enables you to calibrate the flowmeter analog output using a different scale than the standard 4-20 mA output scale. Non-scaled D/A trimming (described above), is typically performed using an ammeter where calibration values are entered in units of milliamperes. Scaled D/A trimming allows you to trim the flowmeter using a scale that may be more convenient based upon your method of measurement.

(1) To access these features, you must scroll to this option in the Field Communicator.

For example, it may be more convenient for you to make current measurements by direct voltage readings across the loop resistor. If your loop resistor is 500 ohms, and you want to calibrate the meter using voltage measurements made across this resistor, you could rescale your trim points from 4-20 mA to 4-20 mA x 500 ohm or 2-10 Vdc. Once your scaled trim points have been entered as 2 and 10, you can calibrate your flowmeter by entering voltage measurements directly from the voltmeter.

Digital Trim

| | |
|-----------|------------|
| Fast Keys | 1, 2, 5, 3 |
|-----------|------------|

Digital trim is the function by which the factory calibrates the transmitter. This procedure is rarely needed by users. It is only necessary if you suspect the Rosemount 8732 is no longer accurate. A Rosemount 8714 Calibration Standard is required to complete a digital trim. Attempting a digital trim without a Rosemount 8714 calibration may result in an inaccurate transmitter or an error message. Digital trim must be performed only with the coil drive mode set to 5 Hz and with a nominal sensor calibration number stored in the memory.

NOTE

Attempting a digital trim without a Rosemount 8714 standard may result in an inaccurate transmitter, or a "DIGITAL TRIM FAILURE" message may appear. If this message occurs, no values were changed in the transmitter. Simply power down the Rosemount 8732 to clear the message.

To simulate a nominal sensor with the Rosemount 8714 calibration standard, you must change the following four parameters in the Rosemount 8732:

1. Tube Calibration Number—1000015010000000
2. Units—ft/s
3. PV URV—20 mA = 30.00 ft/s
4. PV LRV—4 mA = 0 ft/s
5. Coil Drive Frequency—5 Hz

The instructions for changing the Tube Calibration Number, Units, PV URV, and PV LRV are located in "Basic Setup" on page 3-7. Instructions for changing the Coil Drive Frequency can be found on page 4-19 in this section.

Set the loop to manual, if necessary, before you begin. Complete the following steps:

1. Power down the transmitter.
2. Connect the transmitter to a Rosemount 8714 calibration standard.
3. Power up the transmitter with the Rosemount 8714 connected and read the flow rate. The electronics need about a 5-minute warm-up time to stabilize.
4. Set the 8714 calibration standard to the 30 ft/s (9.1 m/s) setting.
5. The flow rate reading after warm-up should be between 29.97 (9.1 m/s) and 30.03 ft/s (9.2 m/s).
6. If the reading is within the range, return the transmitter to the original configuration parameters.

(1) To access these features, you must scroll to this option in the Field Communicator.

7. If the reading is not within this range, initiate a digital trim with the LOI or Handheld Communicator. The digital trim takes about 90 seconds to complete. No transmitter adjustments are required.

Auto Zero

| | |
|-----------|------------|
| Fast Keys | 1, 2, 5, 4 |
|-----------|------------|

The auto zero function initializes the transmitter for use with the 37 Hz coil drive mode only. Run this function only with the transmitter and sensor installed in the process. The sensor must be filled with the operating process fluid at zero flow. Before running the auto zero function, be sure the coil drive mode is set to 37 Hz (Auto Zero will not run with the coil drive frequency set at 5 Hz).

Set the loop to manual if necessary and begin the auto zero procedure. The transmitter completes the procedure automatically in about 90 seconds. A symbol appears in the lower right-hand corner of the display to indicate that the procedure is running.

Universal Trim

| | |
|-----------|------------|
| Fast Keys | 1, 2, 5, 5 |
|-----------|------------|

The universal auto trim function enables the Rosemount 8732 to calibrate sensors that were not calibrated at the Rosemount factory. The function is activated as one step in a procedure known as in-process calibration. If your Rosemount sensor has a 16-digit calibration number, in-process calibration is not required. If it does not, or if your sensor is made by another manufacturer, complete the following steps for in-process calibration.

1. Determine the flow rate of the process fluid in the sensor.

NOTE

The flow rate in the line can be determined by using another sensor in the line, by counting the revolutions of a centrifugal pump, or by performing a bucket test to determine how fast a given volume is filled by the process fluid.

2. Complete the universal auto trim function.
3. When the routine is completed, the sensor is ready for use.

Status

| | |
|-----------|---------|
| Fast Keys | 1, 2, 6 |
|-----------|---------|

Status displays a summary of the health of the transmitter. If there are any alerts or error messages that have activated, they will be listed here.

ADVANCED CONFIGURATION

In addition to the basic configuration options and the diagnostic information and controls, the 8732 has many advanced functions that can also be configured as required by the application.

Rosemount 8732

DETAILED SETUP

| | |
|-----------|------|
| Fast Keys | 1, 4 |
|-----------|------|

The detailed setup function provides access to other parameters within the transmitter that can be configured such as coil drive frequency, output parameters, local display configuration, and other general information about the device.

Additional Parameters

| | |
|-----------|---------|
| Fast Keys | 1, 4, 1 |
|-----------|---------|

The additional parameters menu provides a means to configure optional parameters within the 8732 transmitter.

Coil Drive Frequency

| | |
|-----------|------------|
| Fast Keys | 1, 4, 1, 1 |
|-----------|------------|

Coil drive frequency allows pulse-rate selection of the sensor coils.

5 Hz

The standard coil drive frequency is 5 Hz, which is sufficient for nearly all applications.

37 Hz

If the process fluid causes a noisy or unstable output, increase the coil drive frequency to 37.5 Hz. If the 37 Hz mode is selected, perform the auto zero function for optimum performance.

Density Value

| | |
|-----------|------------|
| Fast Keys | 1, 4, 1, 2 |
|-----------|------------|

The density value is used to convert from a volumetric flow rate to a mass flow rate using the following equation:

$$Q_m = Q_v \times \rho$$

Where:

Q_m is the mass flow rate

Q_v is the volumetric flow rate, and

ρ is the fluid density

PV Upper Sensor Limit (USL)

| | |
|-----------|------------|
| Fast Keys | 1, 4, 1, 3 |
|-----------|------------|

The PV USL is the maximum value that the 20 mA value can be set to. This is the upper measuring limit of the transmitter and sensor.

PV Lower Sensor Limit (LSL)

| | |
|-----------|------------|
| Fast Keys | 1, 4, 1, 4 |
|-----------|------------|

The PV LSL is the minimum value that the 4 mA value can be set to. This is the lower measuring limit of the transmitter and sensor.

PV Minimum Span

| | |
|-----------|------------|
| Fast Keys | 1, 4, 1, 5 |
|-----------|------------|

The PV minimum span is the minimum flow range that must separate the 4 mA and 20 mA set point values.

Configure Outputs

| | |
|-----------|---------|
| Fast Keys | 1, 4, 2 |
|-----------|---------|

The configure outputs functionality contains functionality to configure the more advanced features that control the analog, pulse, auxiliary, and totalizer outputs of the transmitter.

Analog Output

| | |
|-----------|------------|
| Fast Keys | 1, 4, 2, 1 |
|-----------|------------|

Under this function the advanced features of the analog output can be configured.

PV Upper Range Value (URV)

| | |
|-----------|---------------|
| Fast Keys | 1, 4, 2, 1, 1 |
|-----------|---------------|

The upper range value (URV), or analog output range, is preset to 30 ft/s at the factory. The units that appear will be the same as those selected under the units parameter.

The URV (20 mA point) can be set for both forward or reverse flow rate. Flow in the forward direction is represented by positive values and flow in the reverse direction is represented by negative values. The URV can be any value from -39.3 ft/s to +39.3 ft/s (-12 m/s to +12 m/s), as long as it is at least 1 ft/s (0.3 m/s) from the lower range value (4 mA point). The URV can be set to a value less than the lower range value. This will cause the transmitter analog output to operate in reverse, with the current increasing for lower (or more negative) flow rates.

NOTE

Line size, special units, and density must be selected prior to configuration of URV and LRV.

PV Lower Range Value (LRV)

| | |
|-----------|---------------|
| Fast Keys | 1, 4, 2, 1, 2 |
|-----------|---------------|

Reset the lower range value (LRV), or analog output zero, to change the size of the range (or span) between the URV and LRV. Under normal circumstances, the LRV should be set to a value near the minimum expected flow rate to maximize resolution. The LRV must be between -39.3 ft/s to +39.3 ft/s (-12 m/s to +12 m/s).

NOTE

The LRV can be set to a value greater than the URV, which will cause the analog output to operate in reverse. In this mode, the analog output will increase with lower (more negative) flow rates.

Example

If the URV is greater than the LRV, the analog output will saturate at 3.9 mA when the flow rate falls below the selected 4 mA point. The minimum allowable span between the URV and LRV is 1 ft/s. Do not set the LRV within 1 ft/s (0.3 m/s) of the 20 mA point. For example, if the URV is set to 15.67 ft/s (4.8 m/s) and if the desired URV is greater than the LRV, then the highest allowable analog zero setting would be 14.67 ft/s (4.5 m/s). If the desired URV is less than the LRV, then the lowest allowable LRV would be 16.67 ft/s (5.1 m/s).

NOTE

Line size, special units, and density must be selected prior to configuration of URV and LRV.

PV Analog Output (AO)

| | |
|------------------|---------------|
| Fast Keys | 1, 4, 2, 1, 3 |
|------------------|---------------|

The PV analog output displays the current analog output value (mA) of the transmitter corresponding to the current measured flow rate.

Analog Output Alarm Type

| | |
|------------------|---------------|
| Fast Keys | 1, 4, 2, 1, 4 |
|------------------|---------------|

The analog output alarm type displays the alarm mode the 8732 is currently set for. This value is set by a switch on the electronics board. There are two available options for this setting:

- High
- Low

AO Loop Test

| | |
|------------------|---------------|
| Fast Keys | 1, 4, 2, 1, 5 |
|------------------|---------------|

The loop test allows you to drive the transmitter output to a desired electrical current output on terminals 1 and 2. This capability allows you to check the entire current loop prior to start-up. On the LOI the test will end after five minutes if the transmitter is not returned to normal operation manually.

D/A Trim

| | |
|------------------|---------------|
| Fast Keys | 1, 4, 2, 1, 6 |
|------------------|---------------|

The D/A Trim is used to calibrate the 4-20 mA analog loop output from the transmitter. For maximum accuracy, the analog output should be trimmed for your system loop. Use the following steps to complete the Output Trim function.

1. Set the loop to manual, if necessary.
2. Connect a precision ammeter in the 4–20 mA loop.
3. Initiate the Output Trim function with the LOI or Handheld Communicator.
4. Enter the 4 mA meter value when prompted to do so.
5. Enter the 20 mA meter value when prompted to do so.
6. Return the loop to automatic control, if necessary.

The 4–20 mA trim is now completed. You may repeat the 4–20 mA trim to check the results, or use the analog output test.

Scaled D/A Trim

| | |
|------------------|----------------------|
| Fast Keys | 1, 4, 2, 1, 7 |
|------------------|----------------------|

Scaled D/A trim enables you to calibrate the flowmeter analog output using a different scale than the standard 4-20 mA output scale. Non-scaled D/A trimming (described above), is typically performed using an ammeter where calibration values are entered in units of milliamperes. Scaled D/A trimming allows you to trim the flowmeter using a scale that may be more convenient based upon your method of measurement.

For example, it may be more convenient for you to make current measurements by direct voltage readings across the loop resistor. If your loop resistor is 500 ohms, and you want to calibrate the meter using voltage measurements made across this resistor, you could rescale your trim points from 4-20 mA to 4-20 mA x 500 ohm or 2-10 Vdc. Once your scaled trim points have been entered as 2 and 10, you can calibrate your flowmeter by entering voltage measurements directly from the voltmeter.

Alarm Level

| | |
|------------------|----------------------|
| Fast Keys | 1, 4, 2, 1, 8 |
|------------------|----------------------|

The alarm level allows you to drive the transmitter to preset values if an alarm occurs. There are two options:

- Rosemount Alarm and Saturation Values

Table 4-1. Rosemount Values

| Level | 4-20 mA Saturation | 4-20 mA Alarm |
|-------|--------------------|---------------|
| Low | 3.9 mA | 3.75 mA |
| High | 20.8 mA | 22.6 mA |

- NAMUR-Compliant Alarm and Saturation Values

Table 4-2. NAMUR Values

| Level | 4-20 mA Saturation | 4-20 mA Alarm |
|-------|--------------------|---------------|
| Low | 3.8 mA | 3.5 mA |
| High | 20.5 mA | 22.6 mA |

AO Diag Alarm

| | |
|------------------|----------------------|
| Fast Keys | 1, 4, 2, 1, 9 |
|------------------|----------------------|

AO Diag alarm enables you to configure the alarms associated with the following diagnostics: Empty Pipe, Reverse Flow, Grounding/Wiring, High Process Noise, Electronics Temperature, Coated Electrode Detection, Totalizer Limits, Flow Limits, and Continuous Smart Meter Verification. If any of the selected diagnostics are active, it will cause the analog output to go to the configured alarm level.

Note that the transmitter must have been ordered with the auxiliary output option (option code AX) to have access to this functionality.

Empty Pipe

| | |
|------------------|-------------------------|
| Fast Keys | 1, 4, 2, 1, 9, 1 |
|------------------|-------------------------|

Set an analog output alarm for empty pipe diagnostic.

Reverse Flow

| | |
|-----------|------------------|
| Fast Keys | 1, 4, 2, 1, 9, 2 |
|-----------|------------------|

Set an analog output alarm for the reverse flow diagnostic.

Grounding/Wiring Fault

| | |
|-----------|------------------|
| Fast Keys | 1, 4, 2, 1, 9, 3 |
|-----------|------------------|

Set an analog output alarm for the grounding/wiring diagnostic.

High Process Noise

| | |
|-----------|------------------|
| Fast Keys | 1, 4, 2, 1, 9, 4 |
|-----------|------------------|

Set an analog output alarm for the high process noise diagnostic.

Electronics Temperature Out of Range

| | |
|-----------|------------------|
| Fast Keys | 1, 4, 2, 1, 9, 5 |
|-----------|------------------|

Set an analog output alarm for the electronics temperature diagnostic.

Electrode Coating Limit 2

| | |
|-----------|------------------|
| Fast Keys | 1, 4, 2, 1, 9, 6 |
|-----------|------------------|

Set an analog output alarm for the Electrode Coating Limit 2 parameter.

Totalizer Limit 1

| | |
|-----------|------------------|
| Fast Keys | 1, 4, 2, 1, 9, 7 |
|-----------|------------------|

Set an analog output alarm for the Totalizer Limit 1 parameter.

Flow Limit 1

| | |
|-----------|------------------|
| Fast Keys | 1, 4, 2, 1, 9, 8 |
|-----------|------------------|

Set an analog output alarm for the Flow Limit 1 parameter.

Flow Limit 2

| | |
|-----------|------------------|
| Fast Keys | 1, 4, 2, 1, 9, 9 |
|-----------|------------------|

Set an analog output alarm for the Flow Limit 2 parameter.

Continuous Meter Verification

| | |
|-----------|----------------------------------|
| Fast Keys | 1, 4, 2, 1, 9, 10 ⁽¹⁾ |
|-----------|----------------------------------|

Set an analog output alarm for the Continuous Smart Meter Verification diagnostic.

Pulse Output

| | |
|-----------|------------|
| Fast Keys | 1, 4, 2, 2 |
|-----------|------------|

Under this function the pulse output of the 8732 can be configured.

Pulse Scaling

| | |
|-----------|---------------|
| Fast Keys | 1, 4, 2, 2, 1 |
|-----------|---------------|

Transmitter may be commanded to supply a specified frequency between 1 pulse/ day at 39.37 ft/sec (12 m/s) to 10,000 Hz at 1 ft/sec (0.3 m/s).

NOTE

Line size, special units, and density must be selected prior to configuration of the Pulse Scaling factor.

(1) To access these features, you must scroll to this option in the HART Field Communicator.

The pulse output scaling equates one transistor switch closure pulse to a selectable number of volume units. The volume unit used for scaling pulse output is taken from the numerator of the configured flow units. For example, if gal/min had been chosen when selecting the flow rate unit, the volume unit displayed would be gallons.

NOTE

The pulse output scaling is designed to operate between 0 and 10,000 Hz. The minimum conversion factor value is found by dividing the minimum span (in units of volume per second) by 10,000 Hz.

When selecting pulse output scaling, remember that the maximum pulse rate is 10,000 Hz. With the 110 percent overrange capability, the absolute limit is 11,000 Hz. For example, if you want the Rosemount 8732 to pulse every time 0.01 gallons pass through the sensor, and the flow rate is 10,000 gal/min, you will exceed the 10,000 Hz full-scale limit:

$$\frac{10,000 \text{ gal}}{1 \text{ min}} \times \frac{1 \text{ min}}{60 \text{ sec}} \times \frac{1 \text{ pulse}}{0.01 \text{ gal}} = 16666.7 \text{ Hz}$$

The best choice for this parameter depends upon the required resolution, the number of digits in the totalizer, the extent of range required, and the maximum frequency limit of the external counter.

NOTE

For totalizing on the LOI, ten digits are available.

Pulse Width

| | |
|-----------|---------------|
| Fast Keys | 1, 4, 2, 2, 2 |
|-----------|---------------|

The factory default pulse width is 0.5 ms.

The width, or duration, of the pulse width can be adjusted to match the requirements of different counters or controllers (see Figure 4-1 on page 4-17). These are typically lower frequency applications (< 1000 Hz). The transmitter will accept values from 0.1 ms to 650 ms.

For frequencies higher than 1000 Hz, it is recommended to set the pulse mode to 50% duty cycle by setting the Pulse Mode to Frequency Output.

If the pulse width is set too wide (more than 1/2 the period of the pulse) the transmitter will automatically default to a pulse width of 50% duty cycle.

Figure 4-1. Pulse Output

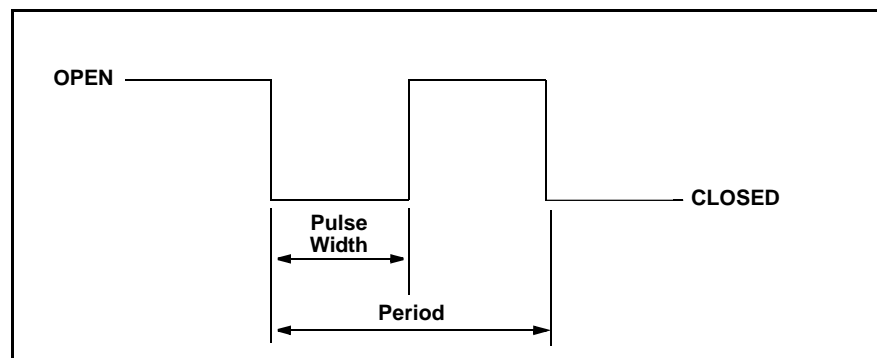

Example

If pulse width is set to 100 ms, the maximum output is 5 Hz; for a pulse width of 0.5 ms, the maximum output would be 1000 Hz (at the maximum frequency output there is a 50 percent duty cycle).

| PULSE WIDTH | MINIMUM PERIOD (50% duty cycle) | MAXIMUM FREQUENCY |
|-------------|---------------------------------|--|
| 100 ms | 200 ms | $\frac{1 \text{ Cycle}}{200 \text{ mS}} = 5 \text{ Hz}$ |
| 0.5 ms | 1.0 ms | $\frac{1 \text{ Cycle}}{1.0 \text{ mS}} = 1000 \text{ Hz}$ |

To achieve the greatest maximum frequency output, set the pulse width to the lowest value that is consistent with the requirements of the pulse output power source, pulse driven external totalizer, or other peripheral equipment.

Example

The maximum flow rate is 10,000 gpm. Set the pulse output scaling such that the transmitter outputs 10,000 Hz at 10,000 gpm.

$$\text{Pulse Scaling} = \frac{\text{Flow Rate (gpm)}}{(60 \text{ s/min})(\text{Frequency})}$$

$$\text{Pulse Scaling} = \frac{10,000 \text{ gpm}}{(60 \text{ s/min})(10,000 \text{ Hz})}$$

$$\text{Pulse Scaling} = 0.0167 \text{ gal/pulse}$$

$$1 \text{ Pulse} = 0.0167 \text{ gallon}$$

NOTE

Changes to pulse width are only required when there is a minimum pulse width required for external counters, relays, etc. If frequency generated by the transmitter requires a smaller pulse width than the pulse width selected, the transmitter will automatically go to 50% duty cycle.

Example

The external counter is ranged for 350 gpm and pulse is set for one gallon. Assuming the pulse width is 0.5 ms, the maximum frequency output is 5.833 Hz.

$$\text{Frequency} = \frac{\text{Flow Rate (gpm)}}{(60 \text{ s/min})(\text{Pulse Scaling gal/pulse})}$$

$$\text{Frequency} = \frac{350 \text{ gpm}}{(60 \text{ s/min})(1 \text{ gal/pulse})}$$

$$\text{Frequency} = 5.833 \text{ Hz}$$

Example

The upper range value (20 mA) is 3000 gpm. To obtain the highest resolution of the pulse output, 10,000 Hz is scaled to the full scale analog reading.

$$\begin{aligned} \text{Pulse Scaling} &= \frac{\text{Flow Rate (gpm)}}{(60 \text{ s/min})(\text{Frequency})} \\ &= \frac{3000 \text{ gpm}}{(60 \text{ s/min})(10,000\text{Hz})} \\ &= 0.005 \text{ gal/pulse} \\ 1 \text{ Pulse} &= 0.005 \text{ gallon} \end{aligned}$$

Pulse Mode

| | |
|------------------|---------------|
| Fast Keys | 1, 4, 2, 2, 3 |
|------------------|---------------|

The Pulse mode configures the frequency output of the pulse. It can be set to either 50% duty cycle, or fixed. There are two options that Pulse Mode can be configured to:

- Pulse Output (User defines a fixed pulse width)
- Frequency Output (Pulse width automatically set to 50% duty cycle)

To use Pulse Width settings, Pulse Mode must be set to Pulse Output.

Pulse Output Loop Test

| | |
|------------------|---------------|
| Fast Keys | 1, 4, 2, 2, 4 |
|------------------|---------------|

The Pulse Output Loop Test allows you to drive the frequency output at terminals 3 and 4 to a desired value. This capability allows you to check auxiliary equipment prior to start-up. On the LOI the test will end after five minutes if the transmitter is not returned to normal operation manually.

DI/DO Output

| | |
|------------------|------------|
| Fast Keys | 1, 4, 2, 3 |
|------------------|------------|

This menu is used to configure the optional digital input and digital output parameters of the 8732 transmitter. Note that this configuration option is only active if the auxiliary output suite (option code AX) was ordered.

DI/DO 1

| | |
|------------------|---------------|
| Fast Keys | 1, 4, 2, 3, 1 |
|------------------|---------------|

Configure the auxiliary output channel 1. This controls the digital input or digital output to the transmitter on terminals 5(-) and 6(+). Note that the transmitter must have been ordered with the auxiliary output option (option code AX) to have access to this functionality.

Configure I/O 1

| | |
|------------------|------------------|
| Fast Keys | 1, 4, 2, 3, 1, 1 |
|------------------|------------------|

Configure channel 1 for either an Input or an Output.

Input – Channel 1 will be configured as a discrete input. Options are:

- PZR – Positive Zero Return. When conditions are met to activate the input, the transmitter will force the output to zero flow.
- Net Total Reset – When conditions are met to activate the input, the transmitter will reset the Net Total value to zero.

Output – Channel 1 will be configured as a discrete output. Options are:

- Reverse Flow – The output will activate when the transmitter detects a reverse flow condition.
- Zero Flow – The output will activate when a no flow condition is detected.
- Transmitter Fault – The output will activate when a transmitter fault condition is detected.
- Empty Pipe – The output will activate when the transmitter detects an empty pipe condition.
- Flow Limit 1 – The output will activate when the transmitter measures a flow rate that meets the conditions established for the Flow Limit 1 Alert.
- Flow Limit 2 – The output will activate when the transmitter measures a flow rate that meets the conditions established for the Flow Limit 2 Alert.
- Diagnostic Status Alert – The output will activate when the transmitter detects a condition that meets the configured criteria of the Diagnostic Status Alert.
- Total Limit – The output will activate when the transmitter net total value meets the conditions established for the Total Limit Alert.

D/O 1 Control

| | |
|-----------|------------------|
| Fast Keys | 1, 4, 2, 3, 1, 2 |
|-----------|------------------|

Displays the configuration for Channel 1 as either a discrete Input or Output.

Digital Input 1

| | |
|-----------|------------------|
| Fast Keys | 1, 4, 2, 3, 1, 3 |
|-----------|------------------|

Displays what digital input Channel 1 will be set to when the Control for Channel 1 is set to Input.

Digital Output 1

| | |
|-----------|------------------|
| Fast Keys | 1, 4, 2, 3, 1, 4 |
|-----------|------------------|

Displays what digital output Channel 1 will be set to when the Control for Channel 1 is set to Output.

Digital Output (DO) 2

| | |
|-----------|---------------|
| Fast Keys | 1, 4, 2, 3, 2 |
|-----------|---------------|

Configure the digital output value here. This controls the digital output to the transmitter on terminals 7(-) and 8(+). There are eight options that the digital output can be configured for:

- Reverse Flow – The output will activate when the transmitter detects a reverse flow condition.
- Zero Flow – The output will activate when a no flow condition is detected.
- Transmitter Fault – The output will activate when a transmitter fault condition is detected.
- Empty Pipe – The output will activate when the transmitter detects an empty pipe condition.
- Flow Limit 1 – The output will activate when the transmitter measures a flow rate that meets the conditions established for the Flow Limit 1 Alert.
- Flow Limit 2 – The output will activate when the transmitter measures a flow rate that meets the conditions established for the Flow Limit 2 Alert.
- Diagnostic Status Alert – The output will activate when the transmitter detects a condition that meets the configured criteria of the Diagnostic Status Alert.
- Total Limit – The output will activate when the transmitter net total value meets the conditions established for the Total Limit Alert.

Flow Limit 1

| | |
|-----------|---------------|
| Fast Keys | 1, 4, 2, 3, 3 |
|-----------|---------------|

Configure the parameters that will determine the criteria for activating a HART alert if the measured flow rate falls within a set of configured criteria. This functionality can be used for operating simple batching operations or generating alerts when certain flow conditions are met. This parameter can be configured as a discrete output if the transmitter was ordered with auxiliary outputs enabled (option code AX). If a digital output is configured for Flow Limit 1, the digital output will activate when the conditions for Mode 1 are met.

Control 1

| | |
|-----------|------------------|
| Fast Keys | 1, 4, 2, 3, 3, 1 |
|-----------|------------------|

Turns the Flow Limit 1 HART Alert ON or OFF.

ON – The transmitter will generate a HART alert when the defined conditions are met. If a digital output is configured for Flow Limit 1, the digital output will activate when the conditions for mode 1 are met.

OFF – The transmitter will not generate a HART alert for the Flow Limit 1.

Mode 1

| | |
|-----------|------------------|
| Fast Keys | 1, 4, 2, 3, 3, 2 |
|-----------|------------------|

Mode that determines when the Flow Limit 1 HART Alert will activate.

> High Limit – The HART Alert will activate when the measured flow rate exceeds the High Limit 1 set point.

< Low Limit – The HART Alert will activate when the measured flow rate falls below the Low Limit 1 set point.

In Range – The HART Alert will activate when the measured flow rate is between the High Limit 1 and Low Limit 1 set points.

Out of Range – The HART Alert will activate when the measured flow rate exceeds the High Limit 1 set point or falls below the Low Limit 1 set point.

High Limit 1

| | |
|-----------|------------------|
| Fast Keys | 1, 4, 2, 3, 3, 3 |
|-----------|------------------|

Set the flow rate value that corresponds to the high limit set point for the Flow Limit 1 alert.

Low Limit 1

| | |
|-----------|------------------|
| Fast Keys | 1, 4, 2, 3, 3, 4 |
|-----------|------------------|

Set the flow rate value that corresponds to the low limit set point for the Flow Limit 1 alert.

Flow Limit Hysteresis

| | |
|-----------|------------------|
| Fast Keys | 1, 4, 2, 3, 3, 5 |
|-----------|------------------|

Set the hysteresis band for the flow limit to determine how quickly the transmitter comes out of Alert status. This hysteresis value is used for both Flow Limit 1 and Flow Limit 2.

Flow Limit 2

| | |
|-----------|---------------|
| Fast Keys | 1, 4, 2, 3, 4 |
|-----------|---------------|

Configure the parameters that will determine the criteria for activating a HART alert if the measured flow rate falls within a set of configured criteria. This functionality can be used for operating simple batching operations or generating alerts when certain flow conditions are met. This parameter can be configured as a discrete output if the transmitter was ordered with auxiliary outputs enabled (option code AX). If a digital output is configured for Flow Limit 2, the digital output will activate when the conditions for Mode 2 are met.

Control 2

| | |
|-----------|------------------|
| Fast Keys | 1, 4, 2, 3, 4, 1 |
|-----------|------------------|

Turns the Flow Limit 2 HART Alert ON or OFF.

ON – The transmitter will generate a HART alert when the defined conditions are met. If a digital output is configured for Flow Limit 2, the digital output will activate when the conditions for mode 2 are met.

OFF – The transmitter will not generate a HART alert for the Flow Limit 2.

Mode 2

| | |
|-----------|------------------|
| Fast Keys | 1, 4, 2, 3, 4, 2 |
|-----------|------------------|

Mode that determines when the Flow Limit 2 HART Alert will activate.

> High Limit – The HART Alert will activate when the measured flow rate exceeds the High Limit 2 set point.

< Low Limit – The HART Alert will activate when the measured flow rate falls below the Low Limit 2 set point.

In Range – The HART Alert will activate when the measured flow rate is between the High Limit 2 and Low Limit 2 set points.

Out of Range – The HART Alert will activate when the measured flow rate exceeds the High Limit 2 set point or falls below the Low Limit 2 set point.

High Limit 2

| | |
|-----------|------------------|
| Fast Keys | 1, 4, 2, 3, 4, 3 |
|-----------|------------------|

Set the flow rate value that corresponds to the high limit set point for the Flow Limit 2 alert.

Low Limit 2

| | |
|-----------|------------------|
| Fast Keys | 1, 4, 2, 3, 4, 4 |
|-----------|------------------|

Set the flow rate value that corresponds to the low limit set point for the Flow Limit 2 alert.

Flow Limit Hysteresis

| | |
|-----------|------------------|
| Fast Keys | 1, 4, 2, 3, 4, 5 |
|-----------|------------------|

Set the hysteresis band for the flow limit to determine how quickly the transmitter comes out of Alert status. This hysteresis value is used for both Flow Limit 1 and Flow Limit 2.

Total Limit

| | |
|-----------|---------------|
| Fast Keys | 1, 4, 2, 3, 5 |
|-----------|---------------|

Configure the parameters that will determine the criteria for activating a HART alert if the measured net total falls within a set of configured criteria. This functionality can be used for operating simple batching operations or generating alerts when certain flow conditions are met. This parameter can be configured as a discrete output if the transmitter was ordered with auxiliary outputs enabled (option code AX). If a digital output is configured for Total Limit, the digital output will activate when the conditions for Total Mode are met.

Total Control

| | |
|-----------|------------------|
| Fast Keys | 1, 4, 2, 3, 5, 1 |
|-----------|------------------|

Turns the Total Limit HART Alert ON or OFF.

ON – The transmitter will generate a HART alert when the defined conditions are met.

OFF – The transmitter will not generate a HART alert for the Total Limit.

Total Mode

| | |
|-----------|------------------|
| Fast Keys | 1, 4, 2, 3, 5, 2 |
|-----------|------------------|

Mode that determines when the Total Limit HART Alert will activate.

> High Limit – The HART Alert will activate when the measured net total exceeds the Total High Limit set point.

< Low Limit – The HART Alert will activate when the measured net total falls below the Total Low Limit set point.

In Range – The HART Alert will activate when the measured net total is between the Total High Limit and Total Low Limit set points.

Out of Range – The HART Alert will activate when the measured net total exceeds the Total High Limit set point or falls below the Total Low Limit set point.

Total High Limit

| | |
|-----------|------------------|
| Fast Keys | 1, 4, 2, 3, 5, 3 |
|-----------|------------------|

Set the net total value that corresponds to the high limit set point for the Flow Limit 1 alert.

Total Low Limit

| | |
|-----------|------------------|
| Fast Keys | 1, 4, 2, 3, 5, 4 |
|-----------|------------------|

Set the net total value that corresponds to the low limit set point for the Flow Limit 1 alert.

Total Limit Hysteresis

| | |
|-----------|------------------|
| Fast Keys | 1, 4, 2, 3, 5, 5 |
|-----------|------------------|

Set the hysteresis band for the total limit to determine how quickly the transmitter comes out of Alert status.

Diagnostic Status Alert

| | |
|-----------|---------------|
| Fast Keys | 1, 4, 2, 3, 6 |
|-----------|---------------|

Turn ON / OFF the diagnostics that will cause this Alert to activate.

ON – The Diagnostic Status Alert will activate when a transmitter detects a diagnostic designated as ON.

OFF – The Diagnostic Status Alert will not activate when diagnostics designated as OFF are detected.

Alerts for the following diagnostics can be turned ON or OFF:

- Electronics Failure
- Coil Open Circuit
- Empty Pipe
- Reverse Flow
- Ground/Wiring Fault
- High Process Noise
- Elect Temp Out of Range
- Electrode Coat Limit 1
- Electrode Coat Limit 2
- Cont. Meter Verification

Reverse Flow

| | |
|-----------|------------|
| Fast Keys | 1, 4, 2, 4 |
|-----------|------------|

Enable or disable the transmitter's ability to read reverse flow.

Reverse Flow allows the transmitter to read negative flow. This may occur when flow in the pipe is going the negative direction, or when either electrode wires or coil wires are reversed. This also enables the totalizer to count in the reverse direction.

Totalizer Setup

| | |
|-----------|------------|
| Fast Keys | 1, 4, 2, 5 |
|-----------|------------|

The totalizer setup menu allows for the viewing and configuration of the totalizer parameters.

Totalizer Units

| | |
|-----------|---------------|
| Fast Keys | 1, 4, 2, 5, 1 |
|-----------|---------------|

Totalizer units allow for the configuration of the units that the totalized value will be displayed as. These units are independent of the flow units.

Gross Total

| | |
|-----------|---------------|
| Fast Keys | 1, 4, 2, 5, 2 |
|-----------|---------------|

Measured gross total provides the output reading of the totalizer. This value is the amount of process fluid that has passed through the flowmeter since the totalizer was last reset.

To reset the gross total value, you must change the line size. See “Line Size” on page 3-9 for details on how to change the line size.

Net Total

| | |
|-----------|---------------|
| Fast Keys | 1, 4, 2, 5, 3 |
|-----------|---------------|

Measured net total provides the output reading of the totalizer. This value is the amount of process fluid that has passed through the flowmeter since the totalizer was last reset. When reverse flow is enabled, the net total represents the difference between the total flow in the forward direction less the total flow in the reverse direction.

Reverse Total

| | |
|-----------|---------------|
| Fast Keys | 1, 4, 2, 5, 4 |
|-----------|---------------|

Measured reverse total provides the output reading of the totalizer. This value is the amount of process fluid that has passed through the flowmeter in the reverse direction since the totalizer was last reset. This value is only totalized when reverse flow is enabled.

Start Totalizer

| | |
|-----------|---------------|
| Fast Keys | 1, 4, 2, 5, 5 |
|-----------|---------------|

Start totalizer starts the totalizer counting from its current value.

Stop Totalizer

| | |
|-----------|---------------|
| Fast Keys | 1, 4, 2, 5, 6 |
|-----------|---------------|

Stop totalizer interrupts the totalizer count until it is restarted again. This feature is often used during pipe cleaning or other maintenance operations.

Reset Totalizer

| | |
|-----------|---------------|
| Fast Keys | 1, 4, 2, 5, 7 |
|-----------|---------------|

Reset totalizer resets the net totalizer value to zero. The totalizer must be stopped before resetting. To reset the gross, forward, or reverse total values you must change the line size.

NOTE

The totalizer value is saved in the Non-Volatile memory of the electronics every three seconds. Should power to the transmitter be interrupted, the totalizer value will start at the last saved value when power is re-applied.

Alarm Level

| | |
|------------------|-------------------|
| Fast Keys | 1, 4, 2, 6 |
|------------------|-------------------|

The alarm level allows you to drive the transmitter to preset values if an alarm occurs. There are two options:

- Rosemount Alarm and Saturation Values
- NAMUR-Complaint Alarm and Saturation Levels

| Level | 4-20 mA Saturation | 4-20 mA Alarm |
|-------|--------------------|---------------|
| Low | 3.9 mA | ≤3.75 mA |
| High | 20.8 mA | ≥22.6 mA |

| Level | 4-20 mA Saturation | 4-20 mA Alarm |
|-------|--------------------|---------------|
| Low | 3.8 mA | ≤3.5 mA |
| High | 20.5 mA | ≥22.6 mA |

HART Output

| | |
|------------------|-------------------|
| Fast Keys | 1, 4, 2, 7 |
|------------------|-------------------|

Multidrop configuration refers to the connection of several flowmeters to a single communications transmission line. Communication occurs digitally between a HART-based communicator or control system and the flowmeters. Multidrop mode automatically deactivates the analog output of the flowmeters. Using the HART communications protocol, up to 15 transmitters can be connected on a single twisted pair of wires or over leased phone lines. The use of a multidrop installation requires consideration of the update rate necessary from each transmitter, the combination of transmitter models, and the length of the transmission line. Multidrop installations are not recommended where intrinsic safety is a requirement. Communication with the transmitters can be accomplished with commercially available Bell 202 modems and a host implementing the HART protocol. Each transmitter is identified by a unique address (1-15) and responds to the commands defined in the HART protocol.

Variable Mapping

| | |
|------------------|----------------------|
| Fast Keys | 1, 4, 2, 7, 1 |
|------------------|----------------------|

Variable mapping allows you to configure the variables that are mapped to the tertiary and quaternary variables. The primary variable is fixed to output flow and cannot be configured.

- PV is configured for flow

Primary Variable (PV) is

| | |
|------------------|-------------------------|
| Fast Keys | 1, 4, 2, 7, 1, 1 |
|------------------|-------------------------|

The primary variable is configured for flow. This variable is fixed and cannot be configured.

Secondary Variable (PV) is

| | |
|-----------|------------------|
| Fast Keys | 1, 4, 2, 7, 1, 2 |
|-----------|------------------|

The secondary variable maps the second variable of the transmitter. This variable is a HART only variable and can be read off of the HART signal with a HART enabled input card, or can be burst for use with a HART Tri-Loop to convert the HART signal to an analog output. Options available for mapping to this variable are (* indicates default value):

- Pulse Output
- Gross Total
- Net Total*
- Reverse Total
- Electronic Temp
- Line Noise Value
- 5Hz Signal/Noise Value
- 37Hz Signal/Noise Value
- Empty Pipe Value
- Transmitter Velocity Deviation
- Electrode Coat Value
- Electrode Resistance
- Coil Resistance
- Sensor Cal Deviation
- mA Deviation

Tertiary Variable (TV) is

| | |
|-----------|------------------|
| Fast Keys | 1, 4, 2, 7, 1, 3 |
|-----------|------------------|

The tertiary variable maps the third variable of the transmitter. This variable is a HART only variable and can be read off of the HART signal with a HART enabled input card, or can be burst for use with a HART Tri-Loop to convert the HART signal to an analog output. Options available for mapping to this variable are (* indicates default value):

- Pulse Output
- Gross Total*
- Net Total
- Reverse Total
- Electronic Temp
- Line Noise Value
- 5Hz Signal/Noise Value
- 37Hz Signal/Noise Value
- Empty Pipe Value
- Transmitter Velocity Deviation
- Electrode Coat Value
- Electrode Resistance
- Coil Resistance
- Sensor Cal Deviation
- mA Deviation

Quaternary Variable (QV) is

| | |
|-----------|------------------|
| Fast Keys | 1, 4, 2, 7, 1, 4 |
|-----------|------------------|

The quaternary variable maps the fourth variable of the transmitter. This variable is a HART only variable and can be read off of the HART signal with a HART enabled input card, or can be burst for use with a HART Tri-Loop to convert the HART signal to an analog output. Options available for mapping to this variable are (* indicates default value):

- Pulse Output
- Gross Total
- Net Total
- Reverse Total*
- Electronic Temp
- Line Noise Value
- 5Hz Signal/Noise Value
- 37Hz Signal/Noise Value
- Empty Pipe Value
- Transmitter Velocity Deviation
- Electrode Coat Value
- Electrode Resistance
- Coil Resistance
- Sensor Cal Deviation
- mA Deviation

Polling Address

| | |
|-----------|---------------|
| Fast Keys | 1, 4, 2, 7, 2 |
|-----------|---------------|

Poll Address enables you to set the poll address for a multi-dropped meter. The poll address is used to identify each meter on the multi-drop line. Follow the on-screen instructions to set the address at a number from 1 to 15. To set or change the flowmeter address, establish communication with the selected Rosemount 8732 in the loop.

NOTE

The Rosemount 8732 is set to poll address zero at the factory, allowing it to operate in the standard point-to-point manner with a 4–20 mA output signal. To activate multidrop communication, the transmitter poll address must be changed to a number between 1 and 15. This change deactivates the 4–20 mA analog output, setting it to 4 mA, and disables the failure mode alarm signal.

Number of Request Preambles

| | |
|-----------|---------------|
| Fast Keys | 1, 4, 2, 7, 3 |
|-----------|---------------|

This is the number of preambles required by the 8732 for HART communications.

Number of Response Preambles

| | |
|-----------|---------------|
| Fast Keys | 1, 4, 2, 7, 4 |
|-----------|---------------|

This is the number of preambles sent by the 8732 in response to any host request.

Burst Mode

| | |
|-----------|---------------|
| Fast Keys | 1, 4, 2, 7, 5 |
|-----------|---------------|

Burst Mode Configuration

The Rosemount 8732 includes a burst mode function that broadcasts the primary variable or all dynamic variables approximately three to four times a second. The burst mode is a specialized function used in very specific applications. The burst mode function enables you to select the variables to broadcast while in the burst mode and to select the burst mode option.

The Burst Mode variable enables you to set the Burst Mode to the needs of your application. Options for the Burst Mode setting include:

- Off—Turns off the Burst Mode so that no data are broadcast on the loop.
- On—Turns Burst Mode on so that the data selected under Burst Option are broadcast over the loop.

Additional command options may appear that are reserved and do not apply to the Rosemount 8732.

Burst Option

| | |
|-----------|---------------|
| Fast Keys | 1, 4, 2, 7, 6 |
|-----------|---------------|

Burst option enables you to select the variables to broadcast over the transmitter burst. Choose one of the following options:

- PV—Selects the process variable for broadcast over the transmitter burst.
- Percent Range/Current—Selects the process variable as percent of range and analog output variables for broadcast over the transmitter burst.
- Process vars/crnt—Selects the process variables and analog output variables for broadcast over the transmitter burst.
- Dynamic Vars—Burst all dynamic variables in the transmitter.

LOI Configuration

| | |
|-----------|---------|
| Fast Keys | 1, 4, 3 |
|-----------|---------|

The LOI (local operator interface) configuration contains functionality to configure the LOI outputs of the transmitter.

Language

| | |
|-----------|------------|
| Fast Keys | 1, 4, 3, 1 |
|-----------|------------|

This allows you to configure the display language shown on the LOI. There are five options available:

- English
- Spanish
- Portuguese
- German
- French

Flowrate Display

| | |
|-----------|------------|
| Fast Keys | 1, 4, 3, 2 |
|-----------|------------|

This allows you to configure the items that the LOI will display when at the flowrate screen. There are five options available:

- Flowrate and % Span
- % Span and Net Total
- Flowrate and Net Total
- % Span and Gross Total
- Flowrate and Gross Total

Totalizer Display

| | |
|-----------|------------|
| Fast Keys | 1, 4, 3, 3 |
|-----------|------------|

This allows you to configure the items that the LOI will display when in the totalizer screen. There are two options available:

- Forward Total and Reverse Total
- Net Total and Gross Total

Rosemount 8732

Display Lock

| | |
|-----------|------------|
| Fast Keys | 1, 4, 3, 4 |
|-----------|------------|

This allows you to enable or disable the display lock for the 8732. Enabling the display lock will disable the operator interface keys to prevent inadvertent changes that may be caused by wiping the glass cover.

To lock/unlock the display, hold the **UP ARROW** on the LOI for 10 seconds. When display lock is active, a padlock symbol will flash in the lower right-hand corner of the display.

Signal Processing

| | |
|-----------|---------|
| Fast Keys | 1, 4, 4 |
|-----------|---------|

The 8732 contains several advanced functions that can be used to stabilize erratic outputs caused by process noise. The signal processing menu contains this functionality.

Operating Mode

| | |
|-----------|------------|
| Fast Keys | 1, 4, 4, 1 |
|-----------|------------|

The Operating Mode should be used only when the signal is noisy and gives an unstable output. Filter mode automatically uses 37 Hz coil drive mode and activates signal processing at the factory set default values. When using filter mode, perform an auto zero with no flow and a full sensor. Either of the parameters, coil drive mode or signal processing, may still be changed individually. Turning Signal Processing off or changing the coil drive frequency to 5 Hz will automatically change the Operating Mode from filter mode to normal mode.

Manually Configure Digital Signal Processing (DSP)

| | |
|-----------|------------|
| Fast Keys | 1, 4, 4, 2 |
|-----------|------------|

The 8732 transmitter includes digital signal processing capabilities that can be used to condition the output from the transmitter by enabling noise rejection. See Appendix D: "Digital Signal Processing" for a more information on the DSP functionality.

Status

| | |
|-----------|---------------|
| Fast Keys | 1, 4, 4, 2, 1 |
|-----------|---------------|

Enable or Disable the DSP capabilities. When ON is selected, the Rosemount 8732 output is derived using a running average of the individual flow inputs. Signal processing is a software algorithm that examines the quality of the electrode signal against user-specified tolerances. This average is updated at the rate of 10 samples per second with a coil drive frequency of 5 Hz, and 75 samples per second with a coil drive frequency of 37Hz. The three parameters that make up signal processing (number of samples, maximum percent limit, and time limit) are described below.

Samples

| | |
|------------------|---------------|
| Fast Keys | 1, 4, 4, 2, 2 |
|------------------|---------------|

0 to 125 Samples

The number of samples function sets the amount of time that inputs are collected and used to calculate the average value. Each second is divided into tenths (1/10) with the number of samples equaling the number of 1/10 second increments used to calculate the average.

For example, a value of:

1 averages the inputs over the past 1/10 second

10 averages the inputs over the past 1 second

100 averages the inputs over the past 10 seconds

125 averages the inputs over the past 12.5 seconds

The default value from factory is 90 samples.

% Limit

| | |
|------------------|---------------|
| Fast Keys | 1, 4, 4, 2, 3 |
|------------------|---------------|

0 to 100 Percent

The maximum percent limit is a tolerance band set up on either side of the running average. The percentage value refers to deviation from the running average. For example, if the running average is 100 gal/min, and a 2 percent maximum limit is selected, then the acceptable range is from 98 to 102 gal/min.

Values within the limit are accepted while values outside the limit are analyzed to determine if they are a noise spike or an actual flow change. The default value from factory is 2%.

Time Limit

| | |
|------------------|---------------|
| Fast Keys | 1, 4, 4, 2, 4 |
|------------------|---------------|

0 to 256 Seconds

The time limit parameter forces the output and running average values to the new value of an actual flow rate change that is outside the percent limit boundaries. It thereby limits response time to flow changes to the time limit value rather than the length of the running average.

For example, if the number of samples selected is 100, then the response time of the system is 10 seconds. In some cases this may be unacceptable. By setting the time limit, you can force the 8732 to clear the value of the running average and re-establish the output and average at the new flow rate once the time limit has elapsed. This parameter limits the response time added to the loop. A suggested time limit value of two seconds is a good starting point for most applicable process fluids. The selected signal processing configuration may be turned ON or OFF to suit your needs. The default value from factory is 2 seconds.

Coil Drive Frequency

| | |
|-----------|------------|
| Fast Keys | 1, 4, 4, 3 |
|-----------|------------|

Coil drive frequency allows pulse-rate selection of the sensor coils.

5 Hz

The standard coil drive frequency is 5 Hz, which is sufficient for nearly all applications.

37 Hz

If the process fluid causes a noisy or unstable output, increase the coil drive frequency to 37.5 Hz. If the 37 Hz mode is selected, perform the auto zero function with no flow and a full sensor for optimum performance.

Low Flow Cutoff

| | |
|-----------|------------|
| Fast Keys | 1, 4, 4, 4 |
|-----------|------------|

Low flow cutoff allows the flow rate to be specified below which the outputs are driven to zero flow. The low flow cutoff units are the same as the PV units and cannot be changed. The low flow cutoff value applies to both forward and reverse flows.

Primary Variable Damping

| | |
|-----------|------------|
| Fast Keys | 1, 4, 4, 5 |
|-----------|------------|

0 to 256 Seconds

Primary Variable Damping allows selection of a response time, in seconds, to a step change in flow rate. It is most often used to smooth fluctuations in output.

Universal Trim

| | |
|-----------|---------|
| Fast Keys | 1, 4, 5 |
|-----------|---------|

The universal auto trim function enables the Rosemount 8732 to calibrate sensors that were not calibrated at the Rosemount factory. The function is activated as one step in a procedure known as in-process calibration. If your Rosemount sensor has a 16-digit calibration number, in-process calibration is not required. If it does not, or if your sensor is made by another manufacturer, complete the following steps for in-process calibration.

1. Determine the flow rate of the process fluid in the sensor.

NOTE

The flow rate in the line can be determined by using another sensor in the line, by counting the revolutions of a centrifugal pump, or by performing a bucket test to determine how fast a given volume is filled by the process fluid.

2. Complete the universal auto trim function.
3. When the routine is completed, the sensor is ready for use.

(1) These items are in a list format without numeric labels.
(2) To access these features, you must scroll to this option in the HART Field communicator.

Device Info

| | |
|-----------|---------|
| Fast Keys | 1, 4, 6 |
|-----------|---------|

Information variables are used for identification of Flowmeters in the field and to store information that may be useful in service situations. Information variables have no effect on flowmeter output or process variables.

Manufacturer

| | |
|-----------|------------|
| Fast Keys | 1, 4, 6, 1 |
|-----------|------------|

Manufacturer is an informational variable provided by the factory. For the Rosemount 8732, the Manufacturer is Rosemount.

Tag

| | |
|-----------|------------|
| Fast Keys | 1, 4, 6, 2 |
|-----------|------------|

Tag is the quickest variable to identify and distinguish between flowmeters. Flowmeters can be tagged according to the requirements of your application. The tag may be up to eight characters long.

Descriptor

| | |
|-----------|------------|
| Fast Keys | 1, 4, 6, 3 |
|-----------|------------|

Descriptor is a longer user-defined variable to assist with more specific identification of the particular flowmeter. It is usually used in multi-flowmeter environments and provides 16 characters.

Message

| | |
|-----------|------------|
| Fast Keys | 1, 4, 6, 4 |
|-----------|------------|

The message variable provides an even longer user-defined variable for identification and other purposes. It provides 32 characters of information and is stored with the other configuration data.

Date

| | |
|-----------|------------|
| Fast Keys | 1, 4, 6, 5 |
|-----------|------------|

Date is a user-defined variable that provides a place to save a date, typically used to store the last date that the transmitter configuration was changed.

Device ID

| | |
|-----------|------------|
| Fast Keys | 1, 4, 6, 6 |
|-----------|------------|

This function displays the Device ID of the transmitter. This is one piece of information required to generate a license code to enable diagnostics in the field.

PV Sensor Serial Number (S/N)

| | |
|-----------|------------|
| Fast Keys | 1, 4, 6, 7 |
|-----------|------------|

The PV sensor serial number is the serial number of the sensor connected to the transmitter and can be stored in the transmitter configuration for future reference. The number provides easy identification if the sensor needs servicing or for other purposes.

Sensor Tag

| | |
|-----------|------------|
| Fast Keys | 1, 4, 6, 8 |
|-----------|------------|

Sensor Tag is the quickest and shortest way of identifying and distinguishing between sensors. Sensors can be tagged according to the requirements of your application. The tag may be up to eight characters long.

(1) These items are in a list format without numeric labels.

(2) To access these features, you must scroll to this option in the HART Field communicator.

Write Protect

| | |
|-----------|------------|
| Fast Keys | 1, 4, 6, 9 |
|-----------|------------|

Write protect is a read-only informational variable that reflects the setting of the hardware security switch. If write protect is ON, configuration data is protected and cannot be changed from a HART-based communicator, the LOI, or control system. If write protect is OFF, configuration data may be changed using the communicator, LOI, or control system.

Revision Numbers

| | |
|-----------|----------------------------|
| Fast Keys | 1, 4, 6, 10 ⁽²⁾ |
|-----------|----------------------------|

Revisions numbers are fixed informational variables that provide the revision number for different elements of your Field Communicator and Rosemount 8732. These revision numbers may be required when calling the factory for support. Revision numbers can only be changed at the factory and are provided for the following elements:

NOTE

To access these features, you must scroll to this option in the Field Communicator.

Universal Revision Number

| | |
|-----------|--------------------------------|
| Fast Keys | 1, 4, 6, 10, -- ⁽¹⁾ |
|-----------|--------------------------------|

Universal revision number – Designates the HART Universal Command specification to which the transmitter is designed to conform.

Transmitter Revision Number

| | |
|-----------|--------------------------------|
| Fast Keys | 1, 4, 6, 10, -- ⁽¹⁾ |
|-----------|--------------------------------|

Field device revision number – Designates the revision for the Rosemount 8732 specific command identification for HART compatibility.

Software Revision Number

| | |
|-----------|--------------------------------|
| Fast Keys | 1, 4, 6, 10, -- ⁽¹⁾ |
|-----------|--------------------------------|

This function displays the software revision number of the transmitter. This is one piece of information required to generate a license code to enable diagnostics in the field.

Final Assembly Number

| | |
|-----------|--------------------------------|
| Fast Keys | 1, 4, 6, 10, -- ⁽¹⁾ |
|-----------|--------------------------------|

Final Assembly Number – Factory set number that refers to the electronics of your flowmeter. The number is configured into the flowmeter for later reference.

Construction Materials

| | |
|-----------|----------------------------|
| Fast Keys | 1, 4, 6, 11 ⁽²⁾ |
|-----------|----------------------------|

Construction materials contain information about the sensor that is connected to the transmitter. This information is configured into the transmitter for later reference. This information can be helpful when calling the factory for support.

(1) These items are in a list format without numeric labels.

(2) To access these features, you must scroll to this option in the HART Field communicator.

Flange Type

| | |
|-----------|--------------------------------|
| Fast Keys | 1, 4, 6, 11, -- ⁽¹⁾ |
|-----------|--------------------------------|

Flange type enables you to select the flange type for your magnetic transmitter system. This variable only needs to be changed if you have changed your sensor. Options for this value are:

- 150# ANSI
- 300# ANSI
- 600# ANSI
- 900# ANSI
- 1500# ANSI
- 2500# ANSI
- PN 10
- PN 16
- PN 25
- PN 40
- PN 64
- Wafer
- Other

Flange Material

| | |
|-----------|--------------------------------|
| Fast Keys | 1, 4, 6, 11, -- ⁽¹⁾ |
|-----------|--------------------------------|

Flange material enables you to select the flange material for your magnetic transmitter system. This variable only needs to be changed if you have changed your sensor. Options for this value are:

- Carbon Steel
- 304 Stainless Steel
- 316 Stainless Steel
- Wafer
- Other

Electrode Type

| | |
|-----------|--------------------------------|
| Fast Keys | 1, 4, 6, 11, -- ⁽¹⁾ |
|-----------|--------------------------------|

Electrode type enables you to select the electrode type for your magnetic transmitter system. This variable only needs to be changed if you have replaced electrodes or if you have replaced your sensor. Options for this value are:

- Standard
- Std & Ground
- Bullet
- Other

(1) These items are in a list format without numeric labels.

(2) To access these features, you must scroll to this option in the HART Field communicator.

Electrode Material

| | |
|------------------|--------------------------------------|
| Fast Keys | 1, 4, 6, 11, --⁽¹⁾ |
|------------------|--------------------------------------|

Electrode Material enables you to select the electrode material for your magnetic transmitter system. This variable only needs to be changed if you have replaced electrodes or if you have replaced your sensor. Options for this value are:

- 316L SST
- Nickel Alloy C-276
- Tantalum
- Titanium
- 80% Platinum – 20% Iridium
- Alloy 20
- Other

Liner Material

| | |
|------------------|--------------------------------------|
| Fast Keys | 1, 4, 6, 11, --⁽¹⁾ |
|------------------|--------------------------------------|

Liner material enables you to select the liner material for the attached sensor. This variable only needs to be changed if you have replaced your sensor. Options for this value are:

- PTFE
- ETFE
- PFA
- Polyurethane
- Natural Rubber
- Neoprene
- Other

Section 5 Sensor Installation

| | |
|--|-----------|
| Safety Messages | page 5-1 |
| Sensor Handling | page 5-3 |
| Sensor Mounting | page 5-4 |
| Installation (Flanged Sensor) | page 5-7 |
| Installation (Wafer Sensor) | page 5-10 |
| Installation (Sanitary Sensor) | page 5-12 |
| Grounding | page 5-12 |
| Process Leak Protection (Optional) | page 5-15 |

This section covers the steps required to physically install the magnetic sensor. For electrical connections and cabling see Section 2: "Installation". Instructions and procedures in this section may require special precautions to ensure the safety of the personnel performing the operations. Please refer to the following safety messages before performing any operation in this section.

SAFETY MESSAGES

 This symbol is used throughout this manual to indicate that special attention to warning information is required.

WARNING

Failure to follow these installation guidelines could result in death or serious injury:
Installation and servicing instructions are for use by qualified personnel only. Do not perform any servicing other than that contained in the operating instructions, unless qualified. Verify that the operating environment of the sensor and transmitter is consistent with the appropriate hazardous area approval.
Do not connect a Rosemount 8732 to a non-Rosemount sensor that is located in an explosive atmosphere.

⚠ WARNING

Explosions could result in death or serious injury:

Installation of this transmitter in an explosive environment must be in accordance with the appropriate local, national, and international standards, codes, and practices. Please review the approvals section of the 8732 reference manual for any restrictions associated with a safe installation.

Electrical shock can result in death or serious injury

Avoid contact with the leads and terminals. High voltage that may be present on leads can cause electrical shock.

⚠ WARNING

The sensor liner is vulnerable to handling damage. Never place anything through the sensor for the purpose of lifting or gaining leverage. Liner damage can render the sensor useless.

To avoid possible damage to the sensor liner ends, do not use metallic or spiral-wound gaskets. If frequent removal is anticipated, take precautions to protect the liner ends. Short spool pieces attached to the sensor ends are often used for protection.

Correct flange bolt tightening is crucial for proper sensor operation and life. All bolts must be tightened in the proper sequence to the specified torque limits. Failure to observe these instructions could result in severe damage to the sensor lining and possible sensor replacement.

Emerson Process Management can supply lining protectors to prevent liner damage during removal, installation, and excessive bolt torquing.

SENSOR HANDLING

⚠ Handle all parts carefully to prevent damage. Whenever possible, transport the system to the installation site in the original shipping containers. PTFE-lined sensors are shipped with end covers that protect it from both mechanical damage and normal unrestrained distortion. Remove the end covers just before installation.

Flanged 6- through 36-inch sensors come with a lifting lug on each flange. The lifting lugs make the sensor easier to handle when it is transported and lowered into place at the installation site.

Flanged ½- to 4-inch sensors do not have lugs. They must be supported with a lifting sling on each side of the housing.

Figure 5-1 shows sensors correctly supported for handling and installation. Notice the plywood end pieces are still in place to protect the sensor liner during transportation.

Figure 5-1. Rosemount 8705 Sensor Support for Handling

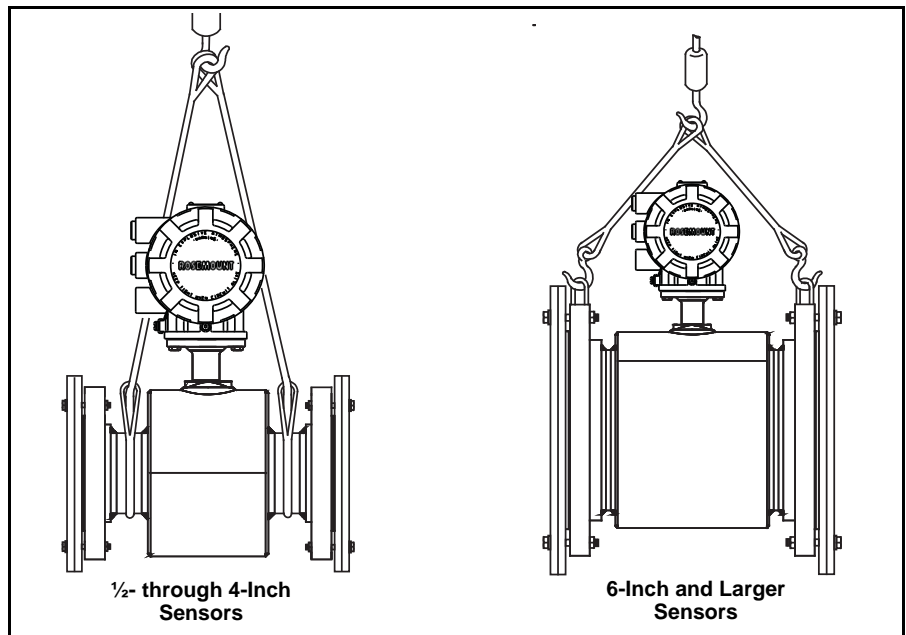

⚠ See "Safety Messages" on pages 5-1 and 5-2 for complete warning information.

Rosemount 8732

SENSOR MOUNTING

Physical mounting of a sensor is similar to installing a typical section of pipe. Conventional tools, equipment, and accessories (bolts, gaskets, and grounding hardware) are required.

Upstream/Downstream Piping

To ensure specification accuracy over widely varying process conditions, install the sensor a minimum of five straight pipe diameters upstream and two pipe diameters downstream from the electrode plane (see Figure 5-2).

Figure 5-2. Upstream and Downstream Straight Pipe Diameters

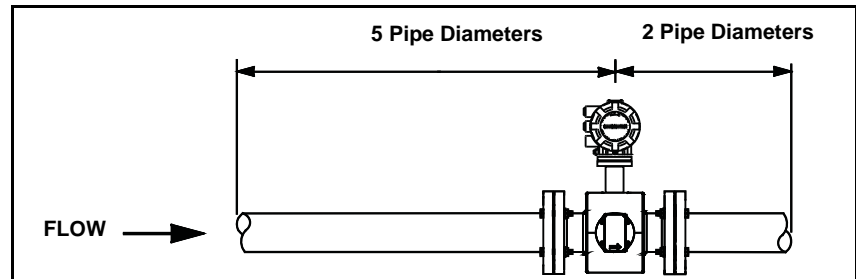

Sensor Orientation

The sensor should be installed in a position that ensures the sensor remains full during operation. Figures 5-3, 5-4, and 5-5 show the proper sensor orientation for the most common installations. The following orientations ensure that the electrodes are in the optimum plane to minimize the effects of entrapped gas.

Vertical installation allows upward process fluid flow and is generally preferred. Upward flow keeps the cross-sectional area full, regardless of flow rate. Orientation of the electrode plane is unimportant in vertical installations. As illustrated in Figures 5-3 and 5-4, avoid *downward* flows where back pressure does not ensure that the sensor remains full at all times.

Installations with reduced straight runs from 0 to five pipe diameters are possible. In reduced straight pipe run installations, performance will shift to as much as 0.5% of rate. Reported flow rates will still be highly repeatable.

Figure 5-3. Vertical Sensor Orientation

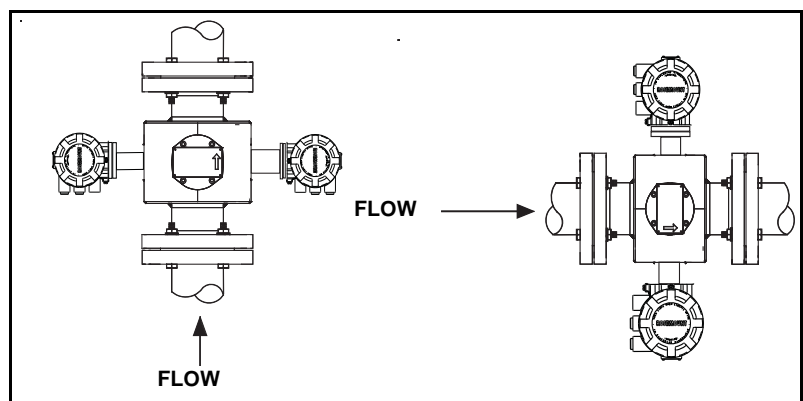
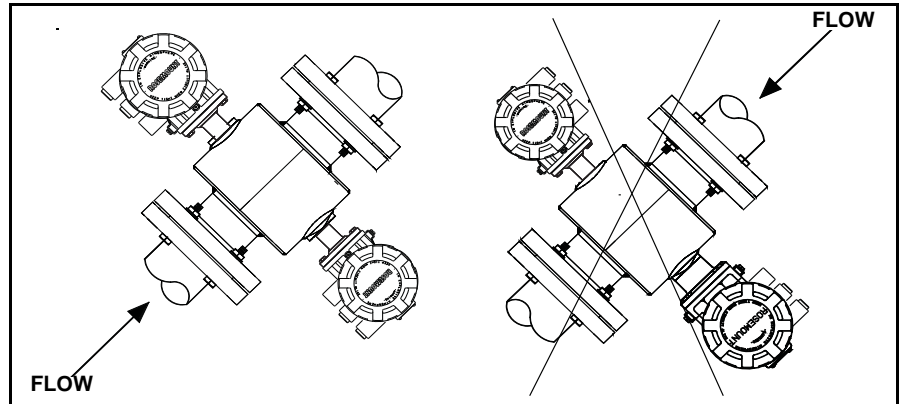
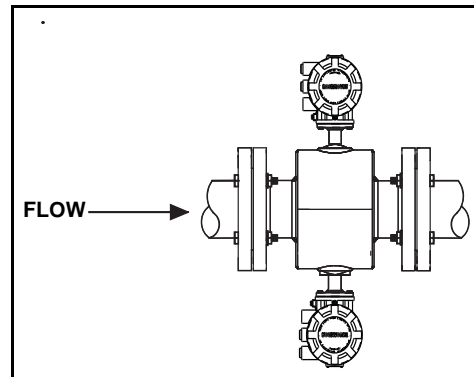

Figure 5-4. Incline or Decline Orientation



Horizontal installation should be restricted to low piping sections that are normally full. Orient the electrode plane to within 45 degrees of horizontal in horizontal installations. A deviation of more than 45 degrees of horizontal would place an electrode at or near the top of the sensor thereby making it more susceptible to insulation by air or entrapped gas at the top of the sensor.

Figure 5-5. Horizontal Sensor Orientation



The electrodes in the Rosemount 8711 are properly oriented when the top of the sensor is either vertical or horizontal, as shown in Figure 5-6. Avoid any mounting orientation that positions the top of the sensor at 45 degrees from the vertical or horizontal position.

Figure 5-6. Rosemount 8711
Mounting Position

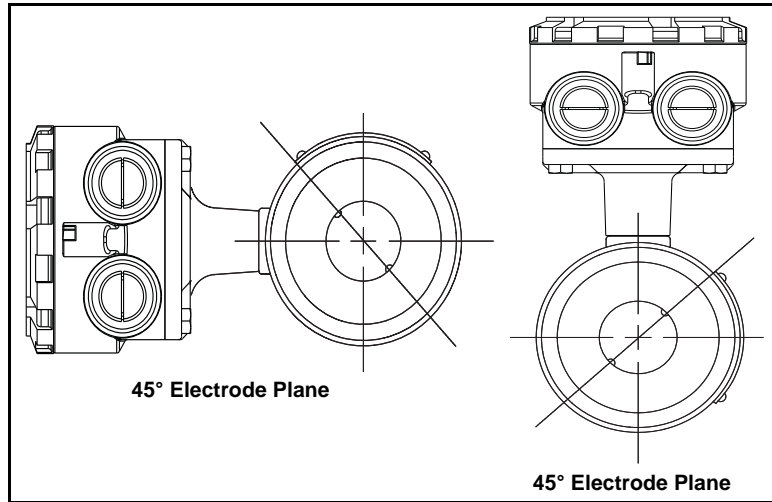

Flow Direction

The sensor should be mounted so that the FORWARD end of the flow arrow, shown on the sensor identification tag, points in the direction of flow through the tube (see Figure 5-7).

Figure 5-7. Flow Direction

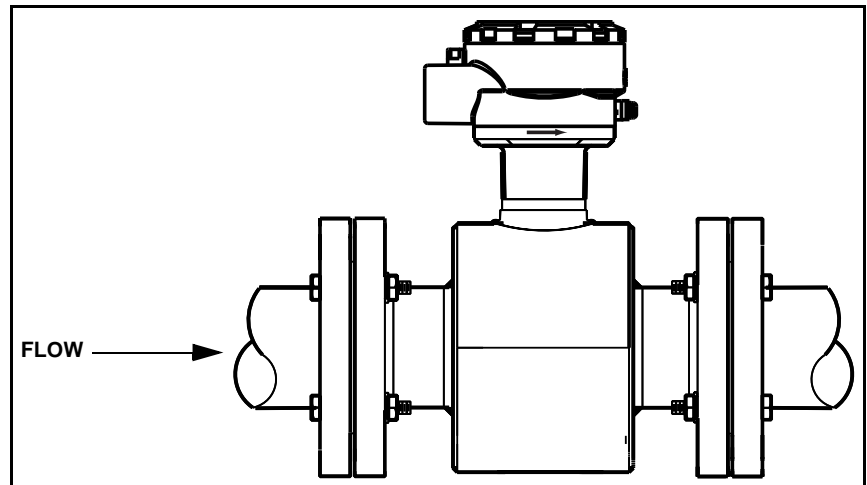

INSTALLATION (FLANGED SENSOR)

The following section should be used as a guide in the installation of the flange-type Rosemount 8705 and Rosemount 8707 High-Signal Sensors. Refer to page 5-10 for installation of the wafer-type Rosemount 8711 Sensor.

Gaskets

⚠ The sensor requires a gasket at each of its connections to adjacent devices or piping. The gasket material selected must be compatible with the process fluid and operating conditions. **Metallic or spiral-wound gaskets can damage the liner.** If the gaskets will be removed frequently, protect the liner ends. All other applications (including sensors with lining protectors or a grounding electrode) require only one gasket on each end connection, as shown in Figure 5-8. If grounding rings are used, gaskets are required on each side of the grounding ring, as shown in Figure 5-9.

Figure 5-8. Gasket Placement

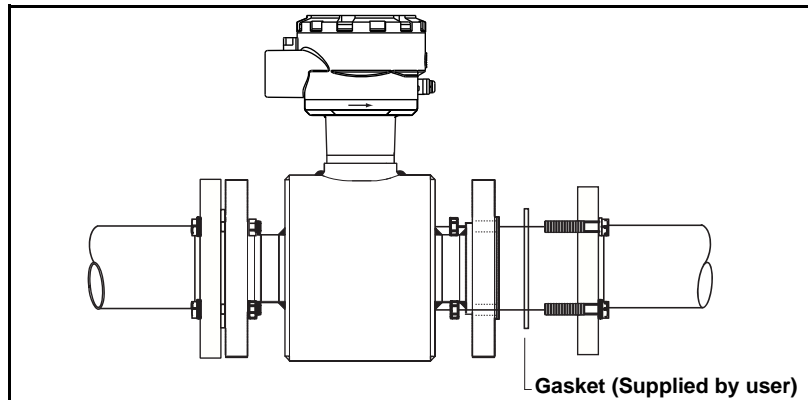
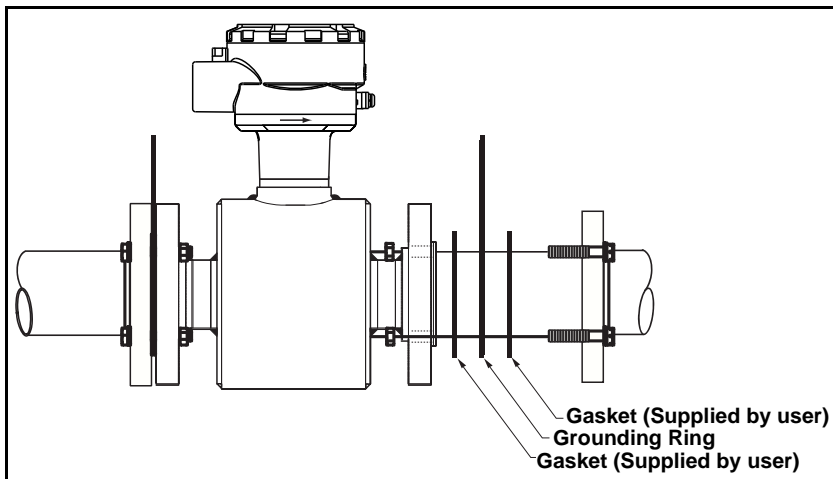

Figure 5-9. Gasket Placement with Non-attached Grounding Rings



Flange Bolts

Suggested torque values by sensor line size and liner type are listed in Table 5-1 on page 5-8 for ASME B16.5 (ANSI) flanges and Table 5-2 and Table 5-3 for DIN flanges. Consult the factory for other flange ratings. Tighten flange bolts in the incremental sequence as shown in Figure 5-10. See Table 5-1 and Table 5-2 for bolt sizes and hole diameters.

⚠ See "Safety Messages" on pages 5-1 and 5-2 for complete warning information.

NOTE

Do not bolt one side at a time. Tighten each side simultaneously. Example:

1. Snug left
2. Snug right
3. Tighten left
4. Tighten right

Do not snug and tighten the upstream side and then snug and tighten the downstream side. Failure to alternate between the upstream and downstream flanges when tightening bolts may result in liner damage.

 Always check for leaks at the flanges after tightening the flange bolts. Failure to use the correct flange bolt tightening methods can result in severe damage. All sensors require a second torquing 24 hours after initial flange bolt tightening.

Table 5-1. Flange Bolt Torque Specifications for Rosemount 8705 and 8707 High-Signal Sensors

| Size Code | Line Size | PTFE/ETFE liner | | | Polyurethane liner | |
|-----------|-----------------|------------------------|------------------------|--|------------------------|------------------------|
| | | Class 150 (pound-feet) | Class 300 (pound-feet) | Class 600 ⁽¹⁾ (Derated to 1000 psi) | Class 150 (pound-feet) | Class 300 (pound-feet) |
| 005 | 0.5-in. (15 mm) | 8 | 8 | 8 | 8 | - |
| 010 | 1-in. (25 mm) | 8 | 12 | 13 | 13 | - |
| 015 | 1.5-in. (40 mm) | 13 | 25 | 29 | 29 | 7 |
| 020 | 2-in. (50 mm) | 19 | 17 | 20 | 20 | 14 |
| 030 | 3-in. (80 mm) | 34 | 35 | 41 | 41 | 23 |
| 040 | 4-in. (100 mm) | 26 | 50 | 68 | 68 | 17 |
| 060 | 6-in. (150mm) | 45 | 50 | 77 | 77 | 30 |
| 080 | 8-in. (200 mm) | 60 | 82 | 121 | 121 | 42 |
| 100 | 10-in. (250 mm) | 55 | 80 | 129 | 129 | 40 |
| 120 | 12-in. (300 mm) | 65 | 125 | 146 | 146 | 55 |
| 140 | 14-in. (350 mm) | 85 | 110 | 194 | 194 | 70 |
| 160 | 16-in. (400 mm) | 85 | 160 | 274 | 274 | 65 |
| 180 | 18-in. (450 mm) | 120 | 170 | 432 | 432 | 95 |
| 200 | 20-in. (500 mm) | 110 | 175 | 444 | 444 | 90 |
| 240 | 24-in. (600 mm) | 165 | 280 | 731 | 731 | 140 |
| 300 | 30-in. (750 mm) | 195 | 375 | - | - | 165 |
| 360 | 36-in. (900 mm) | 280 | 575 | - | - | 245 |

(1) Derated available with PTFE lining only.

For sensors with ANSI 600# full rated, 900#, 1500#, and 2500# flanges, the liner is protected from over-compression by the flange design. Standard flange torque specifications as determined by ANSI and ASME should be followed. No special precaution is required to prevent liner damage caused by over torquing. Bolt tightening procedures laid out in this Reference Manual must still be followed.

To prevent liner damage on any magnetic flowmeter, a flat gasket must be used. For optimum results on meters with high pressure flanges (ANSI 600# or above), it is recommended that a flat full face gasket be used.

Under NO circumstances should a spiral wound or flexitallic gasket be used as this will damage the liner sealing surface.

 See "Safety Messages" on pages 5-1 and 5-2 for complete warning information.

Table 5-2. Flange Bolt Torque and Bolt Load Specifications for Rosemount 8705

| Size Code | Line Size | PTFE/ETFE liner | | | | | | | |
|-----------|--------------------|-----------------|----------|----------------|----------|----------------|----------|----------------|----------|
| | | PN10 | | PN 16 | | PN 25 | | PN 40 | |
| | | (Newton-meter) | (Newton) | (Newton-meter) | (Newton) | (Newton-meter) | (Newton) | (Newton-meter) | (Newton) |
| 005 | 1/2-inch (15 mm) | 7 | 3209 | 7 | 3809 | 7 | 3809 | 7 | 4173 |
| 010 | 1 inch (25 mm) | 13 | 6983 | 13 | 6983 | 13 | 6983 | 13 | 8816 |
| 015 | 1 1/2 inch (40 mm) | 24 | 9983 | 24 | 9983 | 24 | 9983 | 24 | 13010 |
| 020 | 2 inch (50 mm) | 25 | 10420 | 25 | 10420 | 25 | 10420 | 25 | 14457 |
| 030 | 3 inch (80 mm) | 14 | 5935 | 14 | 5935 | 18 | 7612 | 18 | 12264 |
| 040 | 4 inch (100 mm) | 17 | 7038 | 17 | 7038 | 30 | 9944 | 30 | 16021 |
| 060 | 6 inch (150mm) | 23 | 7522 | 32 | 10587 | 60 | 16571 | 60 | 26698 |
| 080 | 8 inch (200 mm) | 35 | 11516 | 35 | 11694 | 66 | 18304 | 66 | 36263 |
| 100 | 10 inch (250 mm) | 31 | 10406 | 59 | 16506 | 105 | 25835 | 105 | 48041 |
| 120 | 12 inch (300 mm) | 43 | 14439 | 82 | 22903 | 109 | 26886 | 109 | 51614 |
| 140 | 14 inch (350 mm) | 42 | 13927 | 80 | 22091 | 156 | 34578 | 156 | 73825 |
| 160 | 16 inch (400 mm) | 65 | 18189 | 117 | 28851 | 224 | 45158 | 224 | 99501 |
| 180 | 18 inch (450 mm) | 56 | 15431 | 99 | 24477 | — | — | — | 67953 |
| 200 | 20 inch (500 mm) | 66 | 18342 | 131 | 29094 | 225 | 45538 | 225 | 73367 |
| 240 | 24 inch (600 mm) | 104 | 25754 | 202 | 40850 | 345 | 63940 | 345 | 103014 |

Figure 5-10. Flange Bolt Torquing Sequence

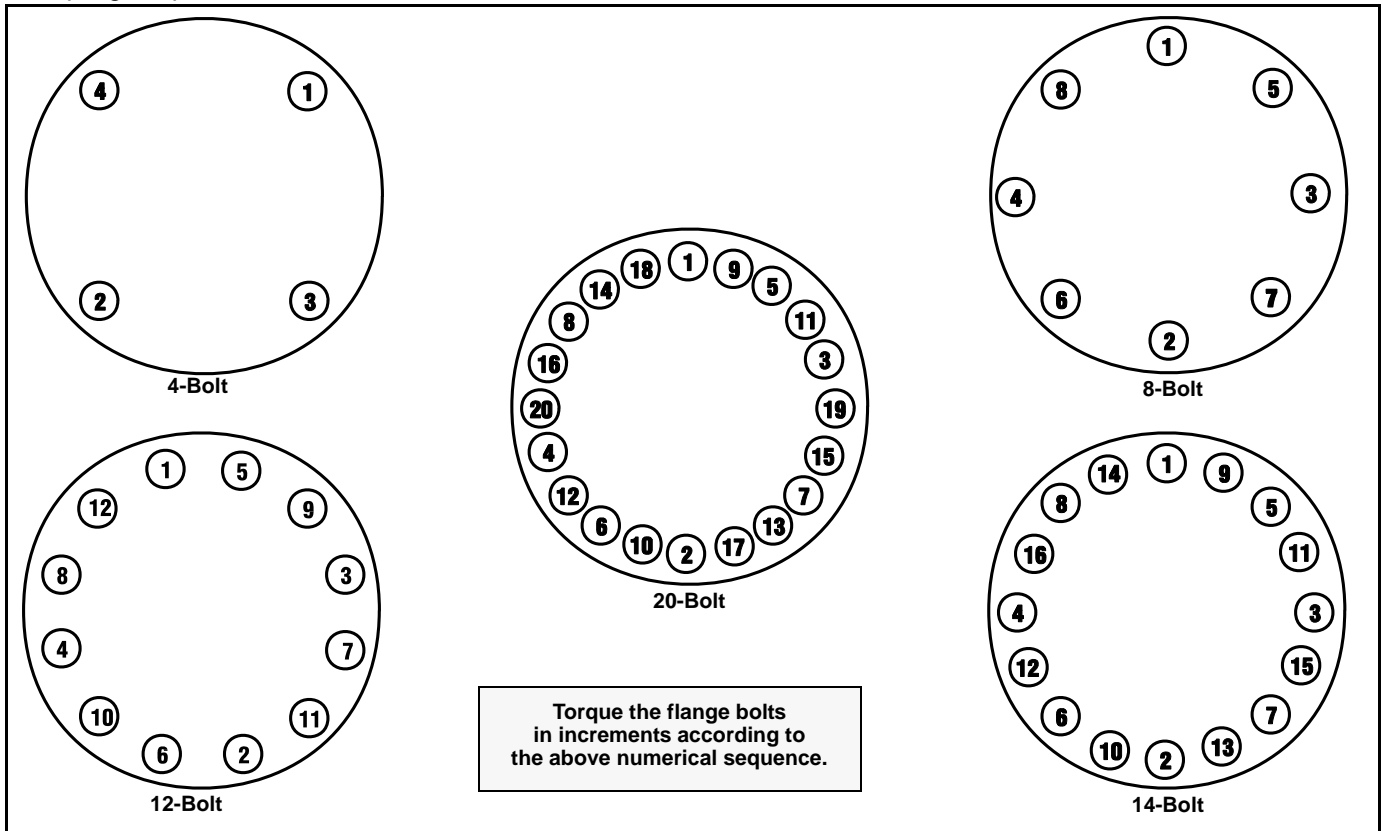

Rosemount 8732

Table 5-3. Flange Bolt Torque and Bolt Load Specifications for Rosemount 8705

| Size Code | Line Size | Polyurethane Liner | | | | | | | |
|-----------|--------------------|--------------------|----------|----------------|----------|----------------|----------|----------------|----------|
| | | PN 10 | | PN 16 | | PN 25 | | PN 40 | |
| | | (Newton-meter) | (Newton) | (Newton-meter) | (Newton) | (Newton-meter) | (Newton) | (Newton-meter) | (Newton) |
| 005 | 1/2-inch (15 mm) | 1 | 521 | 1 | 826 | 2 | 1293 | 6 | 3333 |
| 010 | 1 inch (25 mm) | 2 | 1191 | 3 | 1890 | 5 | 2958 | 10 | 5555 |
| 015 | 1 1/2 inch (40 mm) | 5 | 1960 | 7 | 3109 | 12 | 4867 | 20 | 8332 |
| 020 | 2 inch (50 mm) | 6 | 2535 | 10 | 4021 | 15 | 6294 | 26 | 10831 |
| 030 | 3 inch (80 mm) | 5 | 2246 | 9 | 3563 | 13 | 5577 | 24 | 19998 |
| 040 | 4 inch (100 mm) | 7 | 3033 | 12 | 4812 | 23 | 7531 | 35 | 11665 |
| 060 | 6 inch (150mm) | 16 | 5311 | 25 | 8425 | 47 | 13186 | 75 | 20829 |
| 080 | 8 inch (200 mm) | 27 | 8971 | 28 | 9487 | 53 | 14849 | 100 | 24687 |
| 100 | 10 inch (250 mm) | 26 | 8637 | 49 | 13700 | 87 | 21443 | 155 | 34547 |
| 120 | 12 inch (300 mm) | 36 | 12117 | 69 | 19220 | 91 | 22563 | 165 | 36660 |
| 140 | 14 inch (350 mm) | 35 | 11693 | 67 | 18547 | 131 | 29030 | 235 | 47466 |
| 160 | 16 inch (400 mm) | 55 | 15393 | 99 | 24417 | 189 | 38218 | 335 | 62026 |
| 200 | 20 inch (500 mm) | 58 | 15989 | 114 | 25361 | 197 | 39696 | 375 | 64091 |
| 240 | 24 inch (600 mm) | 92 | 22699 | 178 | 36006 | 304 | 56357 | 615 | 91094 |

INSTALLATION (WAFER SENSOR)

The following section should be used as a guide in the installation of the Rosemount 8711 Sensor. Refer to page 5-7 for installation of the flange-type Rosemount 8705 and 8707 High-Signal sensor.

Gaskets

 The sensor requires a gasket at each of its connections to adjacent devices or piping. The gasket material selected must be compatible with the process fluid and operating conditions. **Metallic or spiral-wound gaskets can damage the liner.** If the gaskets will be removed frequently, protect the liner ends. If grounding rings are used, a gasket is required on each side of the grounding ring.

Alignment and Bolting

1. On 1 1/2 - through 8-inch (40 through 200 mm) line sizes, place centering rings over each end of the sensor. The smaller line sizes, 0.15- through 1-inch (4 through 25 mm), do not require centering rings because the meter is centered by the meter body.
2. Insert studs for the bottom side of the sensor between the pipe flanges. Stud specifications are listed in Table 5-4. **Using carbon steel bolts on smaller line sizes, 0.15- through 1-inch (4 through 25 mm), rather than the required stainless steel bolts, will degrade performance.**

Table 5-4. Stud Specifications

| Nominal Sensor Size | Stud Specifications |
|-----------------------------|--|
| 0.15 – 1 in. (4 – 25 mm) | 316 SST ASTM A193, Grade B8M Class 1 threaded mounted studs |
| 1 1/2 – 8 in. (40 – 200 mm) | CS, ASTM A193, Grade B7, threaded mounting studs |

3. Place the sensor between the flanges. Make sure that the centering rings are properly placed on the studs. The studs should be aligned with the markings on the rings that correspond to the flange you are using.
4. Insert the remaining studs, washers, and nuts.
5. Tighten to the torque specifications shown in Table 5-5. Do not overtighten the bolts or the liner may be damaged.

NOTE

On the 4- and 6- inch PN 10-16, insert the sensor with rings first and then insert the studs. The slots on this ring scenario are located on the inside of the ring.

Figure 5-11. Gasket Placement with Centering Rings

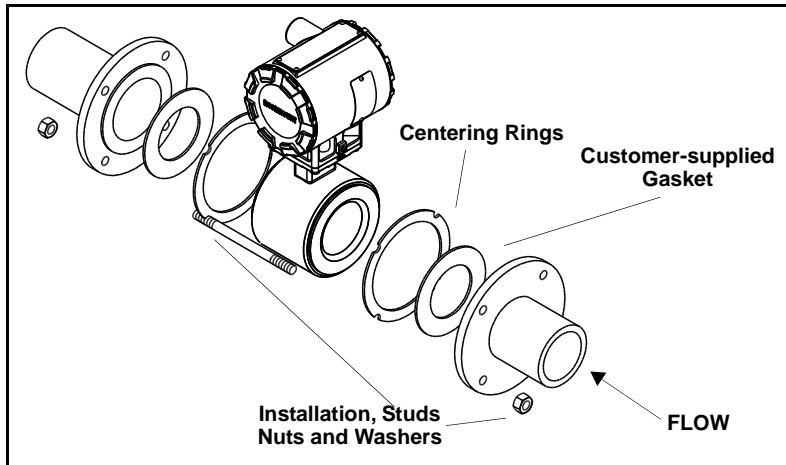

Flange Bolts

Sensor sizes and torque values for both Class 150 and Class 300 flanges are listed in Table 5-5. Tighten flange bolts in the incremental sequence, shown in Figure 5-10.

NOTE

Do not bolt one side at a time. Tighten each side simultaneously. Example:

1. Snug left
2. Snug right
3. Tighten left
4. Tighten right

Do not snug and tighten the upstream side and then snug and tighten the downstream side. Failure to alternate between the upstream and downstream flanges when tightening bolts may result in liner damage.

⚠ Always check for leaks at the flanges after tightening the flange bolts. All sensors require a second torquing 24 hours after initial flange bolt tightening.

Table 5-5. Flange bolt Torque Specifications of Rosemount 8711 Sensors

| Size Code | Line Size | Pound-feet | Newton-meter |
|-----------|--------------------|------------|--------------|
| 15F | 0.15 inch (4 mm) | 5 | 6.8 |
| 30F | 0.30 inch (8 mm) | 5 | 6.8 |
| 005 | 1/2-inch (15 mm) | 5 | 6.8 |
| 010 | 1 inch (25 mm) | 10 | 13.6 |
| 015 | 1 1/2 inch (40 mm) | 15 | 20.5 |
| 020 | 2 inch (50 mm) | 25 | 34.1 |
| 030 | 3 inch (80 mm) | 40 | 54.6 |
| 040 | 4 inch (100 mm) | 30 | 40.1 |
| 060 | 6 inch (150 mm) | 50 | 68.2 |
| 080 | 8 inch (200 mm) | 70 | 81.9 |

**INSTALLATION
(SANITARY SENSOR)**

Gaskets

The sensor requires a gasket at each of its connections to adjacent devices or piping. The gasket material selected must be compatible with the process fluid and operating conditions. Gaskets are supplied with all Rosemount 8721 Sanitary sensors except when the process connection is an IDF sanitary screw type.

Alignment and Bolting

Standard plant practices should be followed when installing a magmeter with sanitary fittings. Unique torque values and bolting techniques are not required.

Figure 5-12. Rosemount 8721 Sanitary Installation

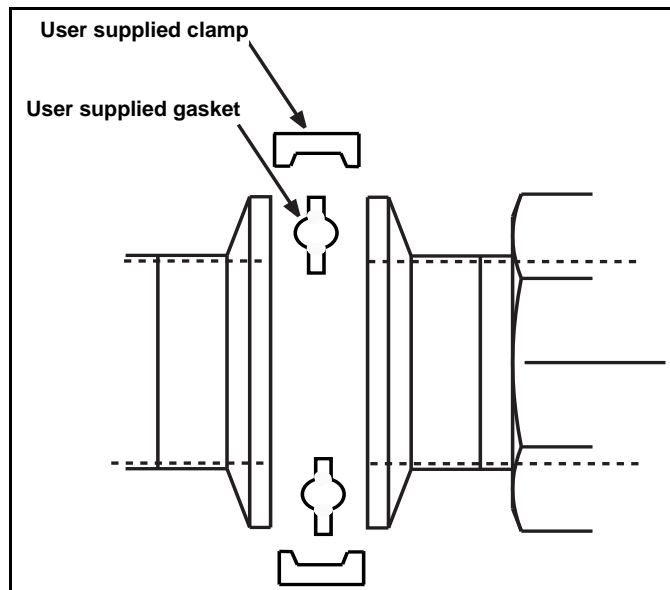

GROUNDING

Process grounding the sensor is one of the most important details of sensor installation. Proper process grounding ensures that the transmitter amplifier is referenced to the process. This creates the lowest noise environment for the transmitter to make a stable reading. Use Table 5-6 to determine which grounding option to follow for proper installation.

NOTE

Consult factory for installations requiring cathodic protection or situations where there are high currents or high potential in the process.

The sensor case should always be earth grounded in accordance with national and local electrical codes. Failure to do so may impair the protection provided by the equipment. The most effective grounding method is direct connection from the sensor to earth ground with minimal impedance.

The Internal Ground Connection (Protective Ground Connection) located inside the junction box is the Internal Ground Connection screw. This screw is identified by the ground symbol: ⊕

Table 5-6. Grounding Installation

| Type of Pipe | Grounding Options | | | |
|-------------------------|------------------------|-----------------|----------------------|-------------------|
| | No Grounding Options | Grounding Rings | Grounding Electrodes | Lining Protectors |
| Conductive Unlined Pipe | See Figure 5-13 | Not Required | Not Required | See Figure 5-14 |
| Conductive Lined Pipe | Insufficient Grounding | See Figure 5-14 | See Figure 5-13 | See Figure 5-14 |
| Non-Conductive Pipe | Insufficient Grounding | See Figure 5-15 | See Figure 5-16 | See Figure 5-15 |

Figure 5-13. No Grounding Options or Grounding Electrode in Lined Pipe

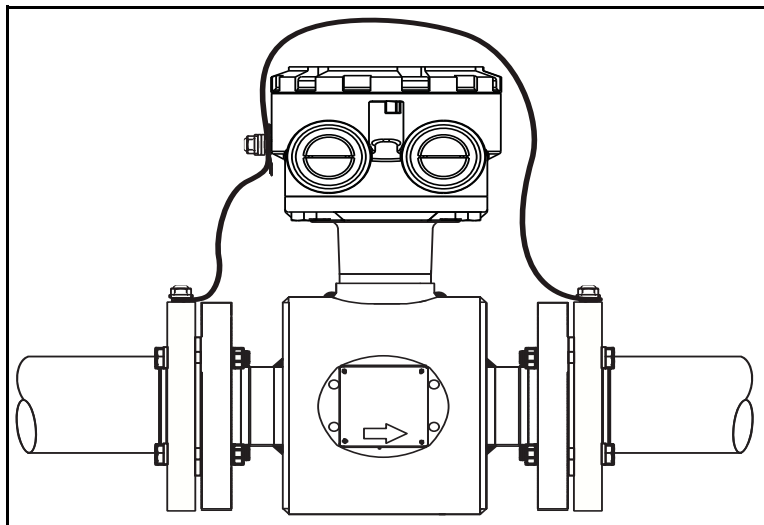

Figure 5-14. Grounding with Grounding Rings or Lining Protectors

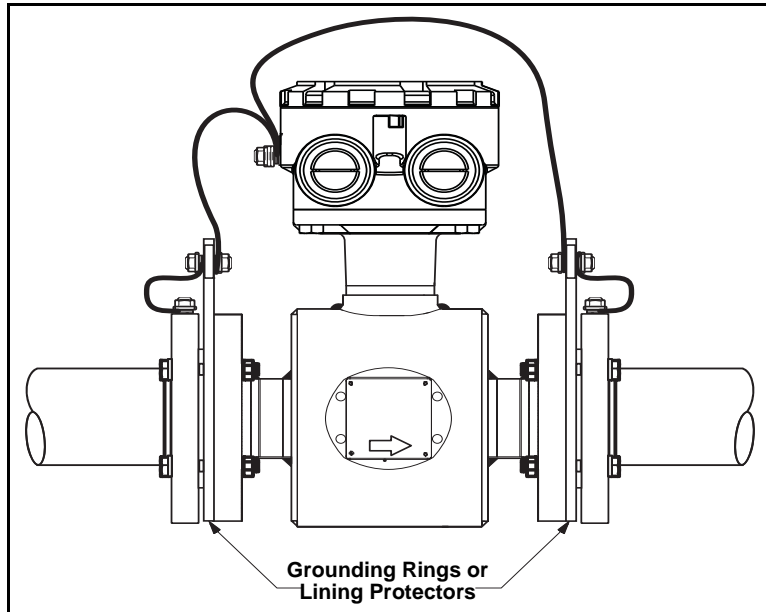

Figure 5-15. Grounding with Grounding Rings or Lining Protectors

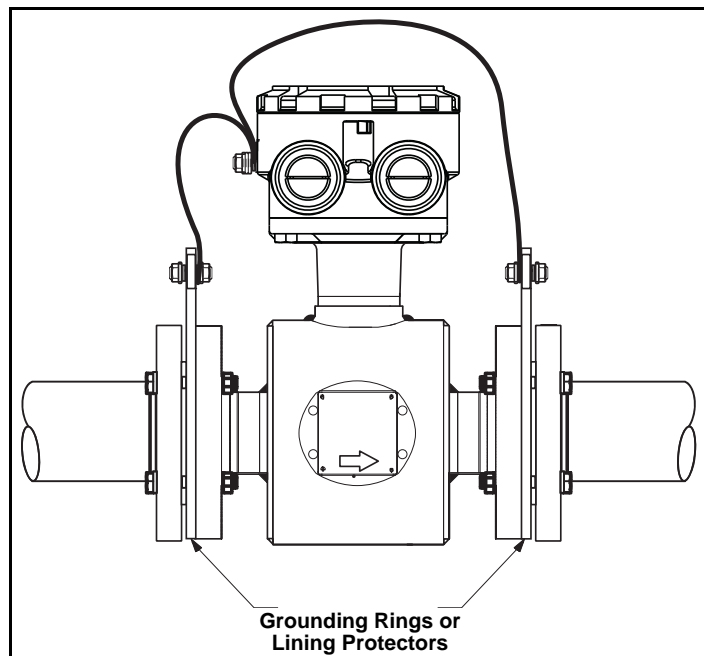
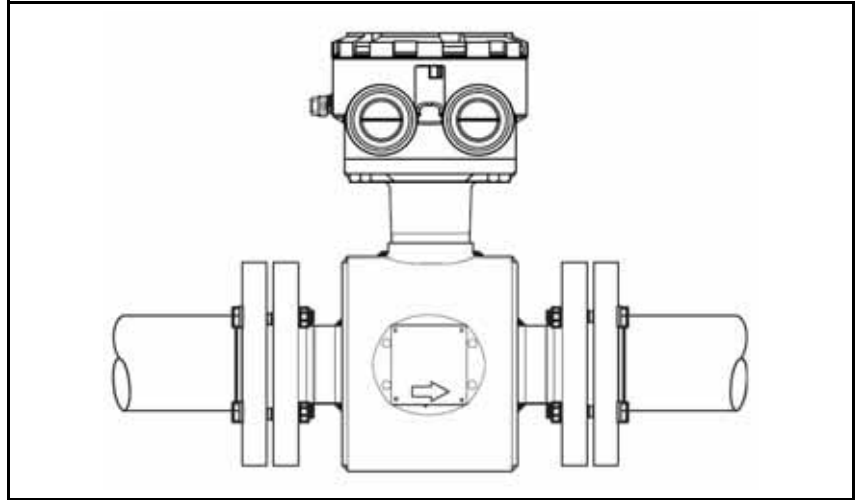

Figure 5-16. Grounding with Grounding Electrodes



PROCESS LEAK PROTECTION (OPTIONAL)

The Rosemount 8705 and 8707 High-Signal Sensor housing is fabricated from carbon steel to perform two separate functions. First, it provides shielding for the sensor magnetics so that external disturbances cannot interfere with the magnetic field and thus affect the flow measurement. Second, it provides the physical protection to the coils and other internal components from contamination and physical damage that might occur in an industrial environment. The housing is completely welded and gasket-free.

The three housing configurations are identified by the W0, W1, or W3 in the model number option code when ordering. Below are brief descriptions of each housing configuration, which are followed by a more detailed overview.

- **Code W0** — sealed, welded coil housing (standard configuration)
- **Code W1** — sealed, welded coil housing with a relief valve capable of venting fugitive emissions to a safe location (additional plumbing from the sensor to a safe area, installed by the user, is required to vent properly)
- **Code W3** — sealed, welded coil housing with separate electrode compartments capable of venting fugitive emissions (additional plumbing from the sensor to a safe area, installed by the user, is required to vent properly)

Standard Housing Configuration

The standard housing configuration is identified by a code W0 in the model number. This configuration does not provide separate electrode compartments with external electrode access. In the event of a process leak, these models will not protect the coils or other sensitive areas around the sensor from exposure to the pressure fluid (Figure 5-17).

Figure 5-17. Standard Housing Configuration — Sealed Welded Housing (Option Code W0)

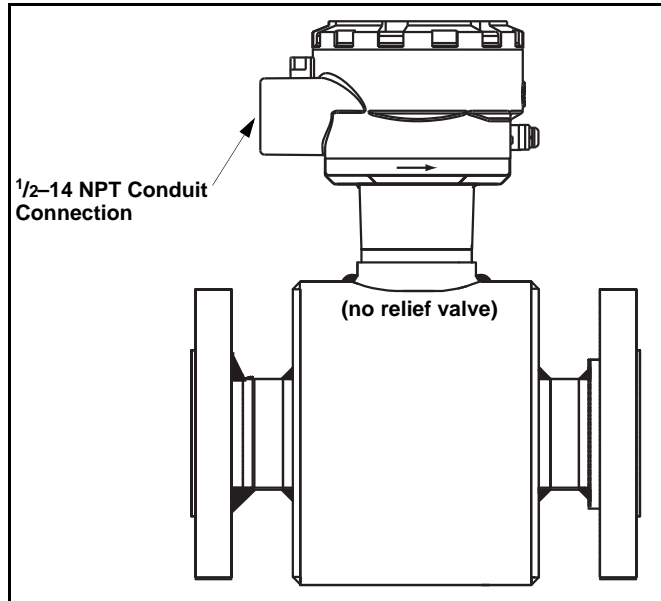

Relief Valves

The first optional configuration, identified by the W1 in the model number option code, uses a completely welded coil housing. This configuration does not provide separate electrode compartments with external electrode access. This optional housing configuration provides a relief valve in the housing to prevent possible overpressuring caused by damage to the lining or other situations that might allow process pressure to enter the housing. The relief valve will vent when the pressure inside the sensor housing exceeds 5 psi. Additional piping (provided by the user) may be connected to this relief valve to drain any process leakage to safe containment (see Figure 5-18).

Figure 5-18. Coil-Housing Configuration — Standard Welded Housing With Relief Valve (Option Code W1)

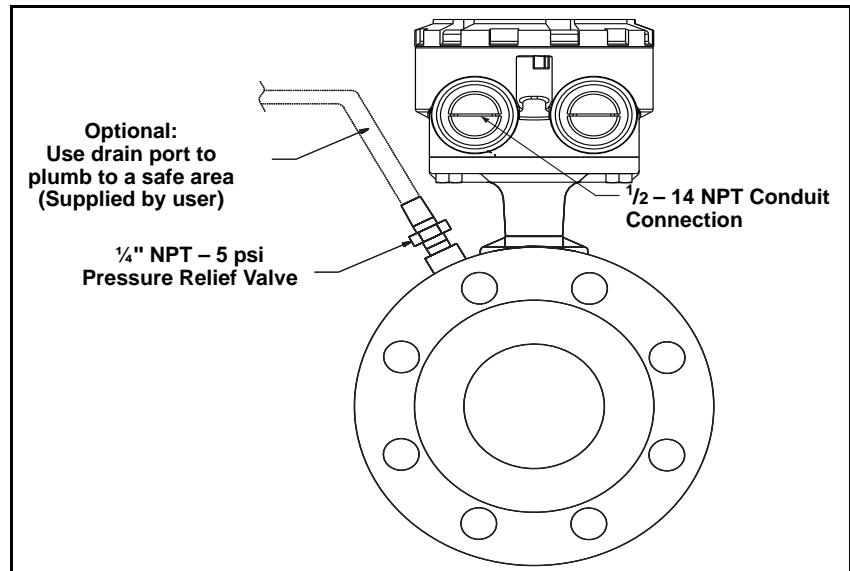

**Process Leak
Containment**

The second optional configuration, identified as option code W3 in the model number, divides the coil housing into three compartments: one for each electrode and one for the coils. Should a damaged liner or electrode fault allow process fluid to migrate behind the electrode seals, the fluid is contained in the electrode compartment. The sealed electrode compartment prevents the process fluid from entering the coil compartment where it would damage the coils and other internal components.

The electrode compartments are designed to contain the process fluid at full line pressure. An o-ring sealed cover provides access to each of the electrode compartments from outside the sensor; drainports are provided in each cover for the removal of fluid.

NOTE

The electrode compartment could contain full line pressure and it must be depressurized before the cover is removed.

Figure 5-19. Housing Configuration — Sealed Electrode Compartment (Option Code W3)

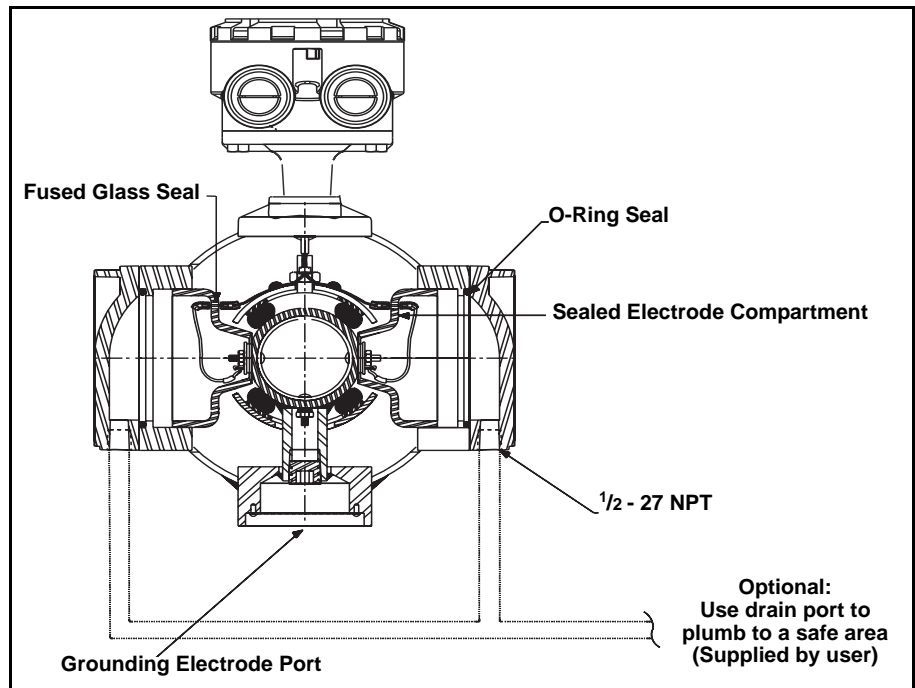

If necessary, capture any process fluid leakage, connect the appropriate piping to the drainports, and provide for proper disposal (see Figure 5-19).

Section 6 Maintenance and Troubleshooting

| | |
|------------------------------------|----------|
| Safety Information | page 6-1 |
| Installation Check and Guide | page 6-2 |
| Diagnostic Messages | page 6-3 |
| Transmitter Troubleshooting | page 6-7 |
| Quick Troubleshooting | page 6-9 |

This section covers basic transmitter and sensor troubleshooting. Problems in the magnetic flowmeter system are usually indicated by incorrect output readings from the system, error messages, or failed tests. Consider all sources when identifying a problem in your system. If the problem persists, consult your local Rosemount representative to determine if the material should be returned to the factory. Emerson Process Management offers several diagnostics that aid in the troubleshooting process.

Instructions and procedures in this section may require special precautions to ensure the safety of the personnel performing the operations. Please read the following safety messages before performing any operation described in this section. Refer to these warnings when appropriate throughout this section.

SAFETY INFORMATION

⚠ WARNING

Failure to follow these installation guidelines could result in death or serious injury:

Installation and servicing instructions are for use by qualified personnel only. Do not perform any servicing other than that contained in the operating instructions, unless qualified. Verify that the operating environment of the sensor and transmitter is consistent with the appropriate FM or CSA approval.

Do not connect a Rosemount 8732 to a non-Rosemount sensor that is located in an explosive atmosphere.

Mishandling products exposed to a hazardous substance may result in death or serious injury. If the product being returned was exposed to a hazardous substance as defined by OSHA, a copy of the required Material Safety Data Sheet (MSDA) for each hazardous substance identified must be included with the returned goods.

The 8732 performs self diagnostics on the entire magnetic flowmeter system: the transmitter, the sensor, and the interconnecting wiring. By sequentially troubleshooting each individual piece of the magmeter system, it becomes easier to pin point the problem and make the appropriate adjustments.

If there are problems with a new magmeter installation, see “Installation Check and Guide” on page 6-2 for a quick guide to solve the most common installation problems. For existing magmeter installations, Table 6-5 lists the most common magmeter problems and corrective actions.

INSTALLATION CHECK AND GUIDE

Use this guide to check new installations of Rosemount magnetic flowmeter systems that appear to malfunction.

Before You Begin

Transmitter

Apply power to your system before making the following transmitter checks.

1. Verify that the correct sensor calibration number is entered in the transmitter. The calibration number is listed on the sensor nameplate.
2. Verify that the correct sensor line size is entered in the transmitter. The line size value is listed on the sensor nameplate.
3. Verify that the analog range of the transmitter matches the analog range in the control system.
4. Verify that the forced analog output and forced pulse output of the transmitter produces the correct output at the control system.

Sensor

Be sure that power to your system is removed before beginning sensor checks.

1. **For horizontal flow installations**, ensure that the electrodes remain covered by process fluid.

For vertical or inclined installations, ensure that the process fluid is flowing up into the sensor to keep the electrodes covered by process fluid.

2. Ensure that the grounding straps on the sensor are connected to grounding rings, lining protectors, or the adjacent pipe flanges. Improper grounding will cause erratic operation of the system.

Wiring

1. The signal wire and coil drive wire must be twisted shielded cable. Emerson Process Management, Rosemount division, recommends 20 AWG twisted shielded cable for the electrodes and 14 AWG twisted shielded cable for the coils. See Table 2-3 on page 2-18.
2. The cable shield must be connected at both ends of the electrode and coil drive cables. Connection of the signal wire shield at both ends is necessary for proper operation. It is recommended that the coil drive wire shield also be connected at both ends for maximum flowmeter performance.
3. The signal and coil drive wires must be separate cables, unless Emerson Process Management specified combo cable is used. See Table 2-3 on page 2-18.
4. The single conduit that houses both the signal and coil drive cables should not contain any other wires.

Process Fluid

1. The process fluid conductivity should be 5 microsiemens (5 micro mhos) per centimeter minimum.
2. The process fluid must be free of air and gasses.
3. The sensor should be full of process fluid.

**DIAGNOSTIC
MESSAGES**

Problems in the magnetic flowmeter system are usually indicated by incorrect output readings from the system, error messages, or failed tests. Consider all sources in identifying a problem in your system.

Table 6-1. Rosemount 8732 Basic Diagnostic Messages

| Message | Potential Cause | Corrective Action |
|---|---|--|
| "Empty Pipe" | Empty Pipe | None - message will clear when pipe is full |
| | Wiring Error | Check that wiring matches appropriate wiring diagrams - see Appendix E: Universal Sensor Wiring Diagrams |
| | Electrode Error | Perform sensor tests C and D (see Table 6-6 on page 6-10) |
| | Conductivity less than 5 microsiemens per cm | Increase Conductivity to greater than or equal to 5 microsiemens per cm |
| | Intermittent Diagnostic | Adjust tuning of Empty Pipe parameters |
| "Coil Open Circuit" | Improper wiring | Check coil drive wiring and sensor coils Perform sensor test A - Sensor Coil |
| | Other manufacturer's sensor | Change coil current to 75 mA Perform a Universal Auto Trim to select the proper coil current |
| | Circuit Board Failure | Replace Rosemount 8732 Electronics |
| | Verify the transmitter is not a Rosemount 8712H | Replace Rosemount 8712H with Rosemount 8712C/U/H/D |
| | Coil Circuit OPEN Fuse | Return to factory for fuse replacement |
| "Auto Zero Failure" | Flow is not set to zero | Force flow to zero, perform autozero |
| | Unshielded cable in use | Change wire to shielded cable |
| | Moisture problems | See moisture problems in "Accuracy Section" |
| "Auto-Trim Failure" | No flow in pipe while performing Universal Auto Trim | Establish a known flow in tube, and perform Universal Auto-Trim calibration |
| | Wiring error | Check that wiring matches appropriate wiring diagrams - see "Universal Sensor Wiring Diagrams" on page E-1 |
| | Flow rate is changing in pipe while performing Universal Auto-Trim routine | Establish a constant flow in tube, and perform Universal Auto-Trim calibration |
| | Flow rate through sensor is significantly different than value entered during Universal Auto-Trim routine | Verify flow in tube and perform Universal Auto-Trim calibration |
| | Incorrect calibration number entered into transmitter for Universal Auto-Trim routine | Replace sensor calibration number with 1000005010000001 |
| | Wrong tube size selected | Correct tube size setting - See "Line Size" on page 3-9 |
| | Sensor failure | Perform sensor tests C and D (see Table 6-6 on page 6-10) |
| "Electronics Failure" | Electronics self check failure | Replace Electronics |
| "Electronics Temp Fail" | Ambient temperature exceeded the electronics temperature limits | Move transmitter to a location with an ambient temperature range of -40 to 165 °F (-40 to 74 °C) |
| "Reverse Flow" | Electrode or coil wires reverse | Verify wiring between sensor and transmitter |
| | Flow is reverse | Turn ON Reverse Flow Enable to read flow |
| | Sensor installed backwards | Re-install sensor correctly, or switch either the electrode wires (18 and 19) or the coil wires (1 and 2) |
| "PZR Activated" (Positive Zero Return) | External voltage applied to terminals 5 and 6 | Remove voltage to turn PZR off |
| "Pulse Out of Range" | The transmitter is trying to generate a frequency greater than 11,000 Hz | Increase pulse scaling to prevent pulse output going above 11,000 Hz Verify the sensor calibration number is correctly entered in the electronics |
| "Analog Out of Range" | Flow rate is greater than analog output Range | Reduce flow, adjust URV and LRV values Verify the sensor calibration number is correctly entered in the electronics |

Rosemount 8732

Table 6-1. Rosemount 8732 Basic Diagnostic Messages

| Message | Potential Cause | Corrective Action |
|---|---|--|
| "Flowrate > 43 ft/sec" | Flow rate is greater than 43 ft/sec | Lower flow velocity, increase pipe diameter |
| | Improper wiring | Check coil drive wiring and sensor coils Perform sensor test A - Sensor Coil (see Table 6-6 on page 6-10) |
| "Digital Trim Failure" (Cycle power to clear messages, no changes were made) | The calibrator (8714B/C/D) is not connected properly | Review calibrator connections |
| | Incorrect calibration number entered into transmitter | Replace sensor calibration number with 1000005010000001 |
| | Calibrator is not set to 30 FPS | Change calibrator setting to 30 FPS |
| | Bad calibrator | Replace calibrator |

Table 6-2. Rosemount 8732 Advanced Diagnostic Messages (Suite 1 - Option Code DA1)

| Message | Potential Cause | Corrective Action |
|-----------------------------|---|---|
| "Grounding/Wiring Fault" | Improper installation of wiring | See "Sensor Connections" on page 2-18 |
| | Coil/Electrode shield not connected | See "Sensor Connections" on page 2-18 |
| | Improper process grounding | See "Grounding" on page 5-12 |
| | Faulty ground connection | Check wiring for corrosion, moisture in the terminal block, and refer to "Grounding" on page 5-12 |
| | Sensor not full | Verify sensor is full |
| "High Process Noise" | Slurry flows - mining/pulp stock | Decrease the flow rate below 10 ft/s (3 m/s) Complete the possible solutions listed under "Step 2: Process Noise" on page 6-9 |
| | Chemical additives upstream of the sensor | Move injection point downstream of the sensor, or move the sensor Complete the possible solutions listed under "Step 2: Process Noise" on page 6-9 |
| | Electrode not compatible with the process fluid | Refer to the Rosemount Magnetic Flowmeter Material Selection Guide (00816-0100-3033) |
| | Air in line | Move the sensor to another location in the process line to ensure that it is full under all conditions |
| | Electrode coating | Enable Coated Electrode Detection diagnostic Use bulletnose electrodes Downsize sensor to increase flowrate above 3 ft/s (1 m/s) Periodically clean sensor |
| | Styrofoam or other insulating particles | Complete the possible solutions listed under "Step 2: Process Noise" on page 6-9 Consult factory |
| | Low conductivity fluids (below 10 microsiemens/cm) | Trim electrode and coil wires - refer to "Sensor Installation" on page 5-1 |
| "Electrode Coating Level 1" | Coating is starting to buildup on electrode and interfering with measurement signal | Schedule maintenance to clean electrode Use bullet nose electrodes Downsize sensor to increase flow rate above 3ft/s (1ms) |
| | Process fluid conductivity has changed | Verify process fluid conductivity |
| "Electrode Coating Level 2" | Coating has built-up on electrode and is interfering with measurement signal | Schedule maintenance to clean electrode Use bullet nose electrodes Downsize sensor to increase flow rate above 3ft/s (1ms) |
| | Process fluid conductivity has changed | Verify process fluid conductivity |

Table 6-3. Rosemount 8732 Advanced Diagnostic Messages (Suite 2 - Option Code DA2)

| Message | Potential Cause | Corrective Action |
|--------------------------------------|--|--|
| "8714i Failed" | Transmitter Calibration Verification test failed | Verify pass/fail criteria Rerun Smart Meter Verification (8714i) under no flow conditions Verify calibration using 8714D Calibration Standard Perform digital trim Replace electronics board |
| | Sensor Calibration test failed | Verify pass/fail criteria Perform sensor test - see Table 6-6 on page 6-10 |
| | Sensor Coil Circuit test failed | Verify pass/fail criteria Perform sensor test - see Table 6-6 on page 6-10 |
| | Sensor Electrode Circuit test failed | Verify pass/fail criteria Perform sensor test - see Table 6-6 on page 6-10 |
| "4-20 mA loop verification failed" | Analog loop not powered | Check 4-20 mA internal/external loop power switch - see "Internal/External Analog Power" on page 2-6 Check external supply voltage to the transmitter Check for parallel paths in the current loop |
| | Transmitter Failure | Perform transmitter self test Perform manual analog loop test Replace the electronics board |
| "Continous Meter Verification Error" | Transmitter Calibration Verification test failed | Verify pass/fail criteria Run manual Smart Meter Verification (8714i) under no flow conditions. Verify calibration using 8714D Calibration Standard Perform digital trim Replace electronics board |
| | Sensor Calibration test failed | Perform sensor test - see Table 6-6 on page 6-10 |
| | Sensor Coil Circuit test failed | Perform sensor test - see Table 6-6 on page 6-10 |
| | Sensor Electrode Circuit test failed | Perform sensor test - see Table 6-6 on page 6-10 |
| "Simulated Velocity Out of Spec" | Unstable flow rate during the verification test or noisy process | Run manual transmitter verification test with no flow and a full pipe. |
| | Transmitter drift or faulty electronics | Verify transmitter electronics with Model 8714 reference standard. The dial on the 8714 should be set to 30 ft/s (9.14 m/s). The transmitter should be set up with the nominal calibration number (1000015010000000) and 5 Hz coil drive frequency. Perform an electronics trim using the Model 8714 reference standard. If the electronics trim doesn't correct the issue, replace the electronics. |
| "Coil Resistance Out of Spec" | Moisture in the terminal block of the sensor or shorted coil | Perform sensor test - see Table 6-6 on page 6-10 If the problem persists, replace the sensor |
| "Coil Signature Out of Spec" | Moisture in the terminal block of the sensor or shorted coil | Perform sensor test - see Table 6-6 on page 6-10 If the problem persists, replace the sensor |
| | Calibration shift caused by heat cycling or vibration | Perform sensor test - see Table 6-6 on page 6-10 If the problem persists, replace the sensor |
| "Electrode Resistance Out of Spec" | Moisture in the terminal block of the sensor | Perform sensor test - see Table 6-6 on page 6-10 If the problem persists, replace the sensor |
| | Electrode coating | Enable Coated Electrode Detection diagnostic Use bulletnose electrodes Downsize sensor to increases flowrate above 3 ft/s (1 m/s) Periodically clean sensor |
| | Shorted Electrodes | Perform sensor test - see Table 6-6 on page 6-10 If the problem persists, replace the sensor |
| "Analog Output Out of Spec" | Unstable flow rate during the verification test or noisy process | Run manual transmitter verification test with no flow and a full pipe |
| | Analog output is no longer within accuracy specifications | Check the analog loop wiring. Excessive loop resistance can cause an invalid test |

Rosemount 8732

Table 6-4. Basic Troubleshooting–Rosemount 8732

| Symptom | Potential Cause | Corrective Action |
|---|---|--|
| Output at 0 mA | No power to transmitter | Check power source and connections to the transmitter |
| | Blown fuse | Check the fuse and replace with an appropriately rated fuse, if necessary |
| | Electronics failure | Verify transmitter operation with an 8714 Calibration Standard or replace the electronic board |
| | Analog output improperly configured | Check the analog power switch position |
| Output at 4 mA | Open coil drive circuit | Check coil drive circuit connections at the sensor and at the transmitter |
| | Transmitter in multidrop mode | Configure Poll Address to 0 to take transmitter out of multidrop mode |
| | Low Flow Cutoff set too high | Configure Low Flow Cutoff to a lower setting or increase flow to a value above the low flow cutoff |
| | PZR Activated | Open PZR switch at terminals 5 and 6 to deactivate the PZR |
| | Flow is in reverse direction | Enable Reverse Flow function |
| | Shorted coil | Coil check – perform sensor test |
| | Empty pipe | Fill pipe |
| | Electronics failure | Verify transmitter operation with an 8714 Calibration Standard or replace the electronic board |
| Output will not reach 20 mA | Loop resistance is greater than 600 ohms | Reduce loop resistance to less than 600 ohms Perform analog loop test |
| Output at 20.8 mA | Transmitter not ranged properly | Reset the transmitter range values – see “PV URV (Upper Range Value)” on page 3-9; Check tube size setting in transmitter and make sure it matches your actual tube size – see “Line Size” on page 3-9 |
| Output at alarm level | Electronics failure | Cycle power. If alarm is still present, verify transmitter operation with an 8714 Calibration Standard or replace the electronic board |
| Pulse output at zero, regardless of flow | Wiring error | Check pulse output wiring at terminals 3 and 4. Refer to wiring diagram for your sensor and pulse output |
| | PZR activated | Remove signal at terminals 5 and 6 to deactivate the PZR. |
| | No power to transmitter | Check pulse output wiring at terminals 3 and 4. Refer to wiring diagram for your sensor and pulse output Power the transmitter |
| | Reverse flow | Enable Reverse Flow function |
| | Electronics failure | Verify transmitter operation with an 8714 Calibration Standard or replace the electronic board |
| | Pulse output incorrectly configured | Review configuration and correct as necessary |
| Communication problems with the Handheld Communicator | 4–20 mA output configuration | Check analog power switch (internal/external). The Handheld Communicator requires a 4–20 mA output to function |
| | Communication interface wiring problems | Incorrect load resistance (250 Ω minimum, 600 ohm maximum); Check appropriate wiring diagram |
| | Low batteries in the Handheld Communicator | Replace the batteries in the Handheld Communicator – see the communicator manual for instructions |
| | Old revision of software in the Handheld Communicator | Consult your local sales office about updating to the latest revision of software |
| Error Messages on LOI or Handheld Communicator | Many possible causes depending upon the message | See page 3-4 for the LOI or Handheld Communicator messages. |
| Digital input does not register | Input signal does not provide enough counts | Verify that the digital input provided meets the requirements of Figure 2-14 on page 2-17 Perform a loop test to validate the analog control loop Perform a digital to analog trim. This allows the calibration of the analog output with an external reference at operating endpoints of the analog output. |

**TRANSMITTER
 TROUBLESHOOTING**

Table 6-5. Advanced Troubleshooting–Rosemount 8732

| Symptom | Potential Cause | Corrective Action |
|---|--|---|
| Does not appear to be within rated accuracy | Transmitter, control system, or other receiving device not configured properly | Check all configuration variables for the transmitter, sensor, communicator, and/or control system Check these other transmitter settings: <ul style="list-style-type: none"> •Sensor calibration number •Units •Line size Perform a loop test to check the integrity of the circuit – see “Quick Troubleshooting” on page 6-9 |
| | Electrode Coating | Enable Coated Electrode Detection diagnostic Use bulletnose electrodes; Downsize sensor to increase flow rate above 3 ft/s; Periodically clean sensor |
| | Air in line | Move the sensor to another location in the process line to ensure that it is full under all conditions. |
| | Moisture problem | Perform the sensor Tests A, B, C, and D (see Table 6-6 on page 6-10) |
| | Improper wiring | If electrode shield and signal wires are switched, flow indication will be about half of what is expected. Check wiring diagrams for your application. |
| | Flow rate is below 1 ft/s (specification issue) | See accuracy specification for specific transmitter and sensor |
| | Auto zero was not performed when the coil drive frequency was changed from 5 Hz to 37 Hz | Set the coil drive frequency to 37 Hz, verify the sensor is full, verify there is no flow, and perform the auto zero function. |
| | Sensor failure–Shorted electrode | Perform the sensor Tests C and D (see Table 6-6 on page 6-10) |
| | Sensor failure–Shorted or open coil | Perform the sensor Tests A and B (see Table 6-6 on page 6-10) |
| | Transmitter failure | Verify transmitter operation with an 8714 Calibration Standard or replace the electronic board |
| Noisy Process | Chemical additives upstream of magnetic flowmeter | Complete the Noisy Process Basic procedure. Move injection point downstream of magnetic flowmeter, or move magnetic flowmeter. |
| | Sludge flows–Mining/Coal/Sand/Slurries (other slurries with hard particles) | Decrease flow rate below 10 ft/s |
| | Styrofoam or other insulating particles in process | Complete the Noisy Process Basic procedure; Consult factory |
| | Electrode coating | Enable Coated Electrode Detection diagnostic Use replaceable electrodes in Rosemount 8705. Use a smaller sensor to increase flow rate above 3 ft/s. Periodically clean sensor. |
| | Air in line | Move the sensor to another location in the process line to ensure that it is full under all conditions. |
| | Low conductivity fluids (below 10 microsiemens/cm) | <ul style="list-style-type: none"> • Trim electrode and coil wires – see “Conduit Cables” on page 2-8 • Keep flow rate below 3 FPS • Integral mount transmitter • Use 8712-0752-1,3 cable • Use N0 approval sensor |

Table 6-5. Advanced Troubleshooting—Rosemount 8732

| Symptom | Potential Cause | Corrective Action |
|---|---|--|
| Meter output is unstable | Medium to low conductivity fluids (10–25 microsiemens/cm) combined with cable vibration or 60 Hz interference | Eliminate cable vibration: <ul style="list-style-type: none"> • Integral mount • Move cable to lower vibration run • Tie down cable mechanically • Trim electrode and coil wires • See “Conduit Cables” on page 2-8 • Route cable line away from other equipment powered by 60 Hz • Use 8712-0752-1,3 cable |
| | Electrode incompatibility | Check the Technical Data Sheet, Magnetic Flowmeter Material Selection Guide (document number 00816-0100-3033), for chemical compatibility with electrode material. |
| | Improper grounding | Check ground wiring – see “Mount the Transmitter” on page 2-4 for wiring and grounding procedures |
| | High local magnetic or electric fields | Move magnetic flowmeter (20–25 ft away is usually acceptable) |
| | Control loop improperly tuned | Check control loop tuning |
| | Sticky valve (look for periodic oscillation of meter output) | Service valve |
| | Sensor failure | Perform the sensor Tests A, B, C, and D (See Table 6-6 on page 6-10) |
| Analog output loop problem | Check that the 4 to 20 mA loop matches the digital value. Perform analog output test. | |
| Reading does not appear to be within rated accuracy | Transmitter, control system, or other receiving device not configured properly | Check all configuration variables for the transmitter, sensor, communicator, and/or control system Check these other transmitter settings: Sensor calibration number Units Line size |
| | Electrode coating | Enable Coated Electrode Detection diagnostic Use bulletnose electrodes in the Rosemount 8705 Sensor. Downsize the sensor to increase the flow rate above 3 ft/s. Periodically clean the sensor |
| | Air in line | Move the sensor to another location in the process line to ensure that it is full under all conditions |
| | Flow rate is below 1 ft/s (specification issue) | See the accuracy specification for specific transmitter and sensor |
| | Insufficient upstream/downstream pipe diameter | Move sensor to location where 5 pipe diameters upstream and 2 pipe diameters downstream is possible |
| | Cables for multiple magmeters run through same conduit | Run only one conduit cable between each sensor and transmitter |
| | Auto zero was not performed when the coil drive frequency was changed from 5 Hz to 37.5 Hz | Perform the auto zero function with full pipe and no flow |
| | Sensor failure—shorted electrode | See Table 6-6 on page 6-10 |
| | Sensor failure—shorted or open coil | See Table 6-6 on page 6-10 |
| | Transmitter failure | Replace the electronics board |
| Transmitter wired to correct sensor | Check wiring | |

QUICK TROUBLESHOOTING

Step 1: Wiring Errors

The most common magmeter problem is wiring between the sensor and the transmitter in remote mount installations. The signal wire and coil drive wire must be twisted shielded cable: 20 AWG twisted shielded cable for the electrodes and 14 AWG twisted shielded cable for the coils. Ensure that the cable shield is connected at both ends of the electrode and coil drive cables. Signal and coil drive wires must have their own cables. The single conduit that houses both the signal and coil drive cables should not contain any other wires. For more information on proper wiring practices, refer to “Transmitter to Sensor Wiring” on page 2-18.

Step 2: Process Noise

In some circumstances, process conditions rather than the magmeter can cause the meter output to be unstable. Possible solutions for addressing a noisy process situation are given below. When the output attains the desired stability, no further steps are required.

Use the Auto Zero function to initialize the transmitter for use with the 37.5 Hz coil drive mode only. Run this function only with the transmitter and sensor installed in the process. The sensor must be filled with process fluid with zero flow rate. Before running the auto zero function, be sure the coil drive mode is set to 37.5 Hz.

Set the loop to manual if necessary and begin the auto zero procedure. The transmitter completes the procedure automatically in about 90 seconds. A symbol appears in the lower right-hand corner of the display to indicate that the procedure is running.

1. Change the coil drive to 37.5 Hz. Complete the Auto Zero function, if possible (see “Coil Drive Frequency” on page 4-12).
2. Turn on Digital Signal Processing (see “Signal Processing” on page 4-30)
3. Increase the damping (see “Primary Variable Damping” on page 4-32).

If the preceding steps fail to resolve the process noise symptoms, consult your Rosemount sales representative about using a high-signal magnetic flowmeter system.

Step 3: Installed Sensor Tests

If a problem with an installed sensor is identified, Table 6-6 can assist in troubleshooting the sensor. Before performing any of the sensor tests, disconnect or turn off power to the transmitter. To interpret the results, the hazardous location certification for the sensor must be known. Applicable codes for the Rosemount 8705 are N0, N5, and KD. Applicable codes for the Rosemount 8707 are N0 and N5. Applicable codes for the Rosemount 8711 are N0, N5, E5, and CD. Always check the operation of test equipment before each test.

If possible, take all readings from inside the sensor junction box. If the sensor junction box is inaccessible, take measurements as close as possible. Readings taken at the terminals of remote-mount transmitters that are more than 100 feet away from the sensor may provide incorrect or inconclusive information and should be avoided. A sensor circuit diagram is provided in Figure 6-1 on page 6-11.

Rosemount 8732

Table 6-6. Sensor Test

| Test | Sensor Location | Required Equipment | Measuring at Connections | Expected Value | Potential Cause | Corrective Action |
|----------------------------------|--------------------------|------------------------------------|---|--|--|---|
| A. Sensor Coil | Installed or Uninstalled | Multimeter | 1 and 2 = R | $2\Omega \leq R \leq 18\Omega$ | <ul style="list-style-type: none"> Open or Shorted Coil | <ul style="list-style-type: none"> Remove and replace sensor |
| B. Shields to Case | Installed or Uninstalled | Multimeter | 17 and $\frac{1}{\text{---}}$ $\frac{1}{\text{---}}$ and case ground 17 and case ground | $< 0.2\Omega$ | <ul style="list-style-type: none"> Moisture in terminal block Leaky electrode Process behind liner | <ul style="list-style-type: none"> Clean terminal block Remove sensor |
| C. Coil Shield to Coil | Installed or Uninstalled | Multimeter | 1 and $\frac{1}{\text{---}}$ 2 and $\frac{1}{\text{---}}$ | $\infty\Omega (< 1\text{nS})$ $\infty\Omega (< 1\text{nS})$ | <ul style="list-style-type: none"> Process behind liner Leaky electrode Moisture in terminal block | <ul style="list-style-type: none"> Remove sensor and dry Clean terminal block Confirm with sensor coil test |
| D. Electrode Shield to Electrode | Installed | LCR (Set to Resistance and 120 Hz) | 18 and 17 = R_1 19 and 17 = R_2 | R_1 and R_2 should be stable NO: $ R_1 - R_2 \leq 300\Omega$ N5, E5, CD, ED: $ R_1 - R_2 \leq 1500\Omega$ | <ul style="list-style-type: none"> Unstable R_1 or R_2 values confirm coated electrode Shorted electrode Electrode not in contact with process Empty Pipe Low conductivity Leaky electrode | <ul style="list-style-type: none"> Remove coating from sensor wall Use bulletnose electrodes Repeat measurement Pull tube, complete test in Table 6-7 and Table 6-8 on page 6-12 out of line. |

To test the sensor, a multimeter capable of measuring conductance in nanosiemens is preferred. Nanosiemens is the reciprocal of resistance.

$$1 \text{ nanosiemens} = \frac{1}{1 \text{ gigaohm}}$$

or

$$1 \text{ nanosiemens} = \frac{1}{1 \times 10^9 \text{ ohm}}$$

Figure 6-1. Sensor Circuit Diagram

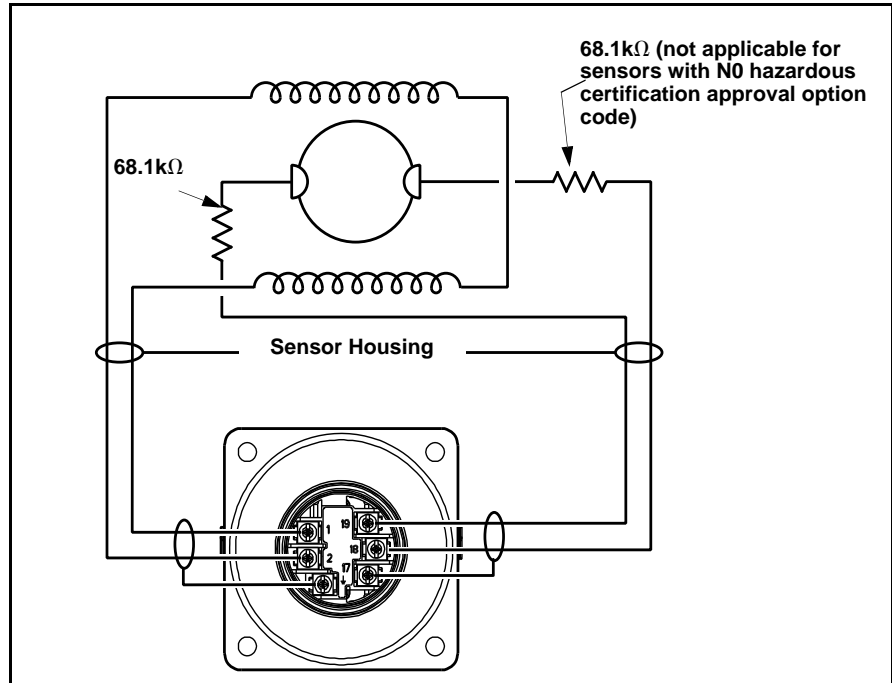

Step 4: Uninstalled Sensor Tests

 An uninstalled sensor can also be used for sensor troubleshooting. To interpret the results, the hazardous location certification for the sensor must be known. Applicable codes for the Rosemount 8705 are N0, N5, and KD. Applicable codes for the Rosemount 8707 are N0 and N5. Applicable codes for the Rosemount 8711 are N0, N5, E5, and CD.

A sensor circuit diagram is provided in Figure 6-1. Take measurements from the terminal block and on the electrode head inside the sensor. The measurement electrodes, 18 and 19, are on opposite sides in the inside diameter. If applicable, the third grounding electrode is in between the other two electrodes. On Rosemount 8711 sensors, electrode 18 is near the sensor junction box and electrode 19 is near the bottom of the sensor (Figure 6-2). The different sensor models will have slightly different resistance readings. Flanged sensor resistance readings are in Table 6-7 while wafer sensor resistance readings are in Table 6-8.

 See "Safety Information" on page 6-1 for complete warning information.

Figure 6-2. 45° Electrode Plane



To insure accuracy of resistance readings, zero out multimeter by shorting and touching the leads together.

Table 6-7. Uninstalled Rosemount 8705 / 8707 Flanged Sensor Tests

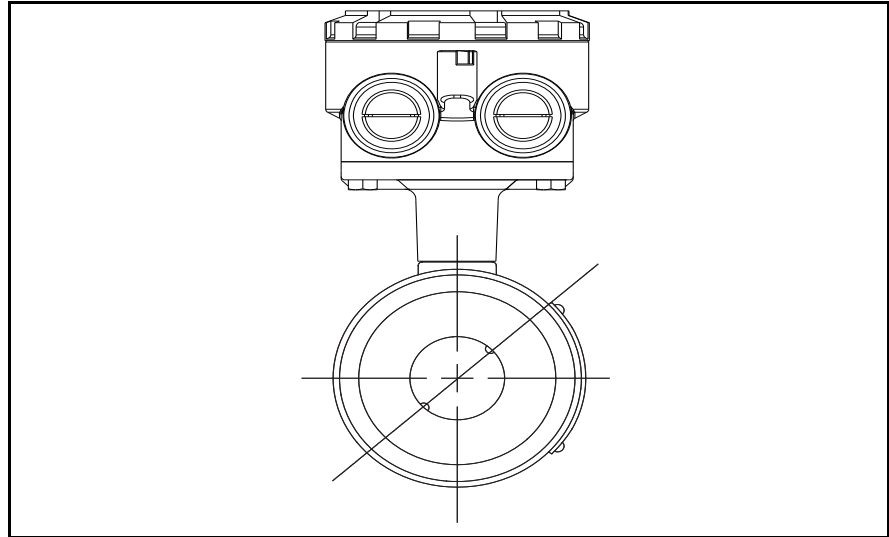
| Measuring at Connections | Hazardous Location Certifications | |
|---------------------------------|-----------------------------------|---|
| | N0 | N5, KD |
| 18 and Electrode ⁽¹⁾ | $\leq 275\Omega$ | $61\text{ k}\Omega \leq R \leq 75\text{ k}\Omega$ |
| 19 and Electrode ⁽¹⁾ | $\leq 275\Omega$ | $61\text{ k}\Omega \leq R \leq 75\text{ k}\Omega$ |
| 17 and Grounding Electrode | $\leq 0.3\Omega$ | $\leq 0.3\Omega$ |
| 17 and Ground Symbol | $\leq 0.3\Omega$ | $\leq 0.3\Omega$ |
| 17 and 18 | Open | Open |
| 17 and 19 | Open | Open |
| 17 and 1 | Open | Open |

(1) It is difficult to tell from visual inspection alone which electrode is wired to which number terminal in the terminal block. Measure both electrodes. One electrode should result in an open reading, while the other electrode should be less than 275Ω .

Table 6-8. Uninstalled Rosemount 8711 Wafer Sensor Tests

| Measuring at Connections | Hazardous Location Certification | |
|---------------------------------|----------------------------------|---|
| | N0 | N5, E5, CD |
| 18 and Electrode ⁽¹⁾ | $\leq 0.3\Omega$ | $61\text{ k}\Omega \leq R \leq 75\text{ k}\Omega$ |
| 19 and Electrode ⁽²⁾ | $\leq 0.3\Omega$ | $61\text{ k}\Omega \leq R \leq 75\text{ k}\Omega$ |
| 17 and Grounding Electrode | $\leq 0.3\Omega$ | $\leq 0.3\Omega$ |
| 17 and Grounding Symbol | $\leq 0.3\Omega$ | $\leq 0.3\Omega$ |
| 17 and 18 | Open | Open |
| 17 and 19 | Open | Open |
| 17 and 1 | Open | Open |

(1) Measure the electrode closest to the junction box

(2) Measure the electrode farthest away from the junction box.

Appendix A Reference Data

| | |
|--|-----------------|
| Rosemount 8732 Transmitter Specifications | page A-1 |
| Functional Specifications | page A-1 |
| Performance Specifications | page A-7 |
| Physical Specifications | page A-9 |

NOTE
Detailed information for all Rosemount Magnetic Flowmeter Products can be found in the latest revision of the 8700 Series Product Data Sheet (p/n 00813-0100-4727).

ROSEMOUNT 8732 TRANSMITTER SPECIFICATIONS

FUNCTIONAL SPECIFICATIONS

Sensor Compatibility

Compatible with Rosemount 8705, 8711, 8721, and 570TM sensors.
Compatible with Rosemount 8707 sensor with D2 Dual calibration option.
Compatible with AC and DC powered sensors of other manufacturers.

Sensor Coil Resistance

350 Ω maximum

Flow Rate Range

Capable of processing signals from fluids that are traveling between 0.04 and 39 ft/s (0.01 to 12 m/s) for both forward and reverse flow in all sensor sizes. Full scale continuously adjustable between -39 and 39 ft/s (-12 to 12 m/s).

Conductivity Limits

Process liquid must have a conductivity of 5 microsiemens/cm (5 micromhos/cm) or greater. Excludes the effect of interconnecting cable length in remote mount transmitter installations.

Power Supply

90 -250 Vac, 50-60 Hz or 12-42 Vdc

AC Power Supply Requirements

Units powered by 90-250 Vac have the following power requirements.

Figure A-1. AC Current Requirements

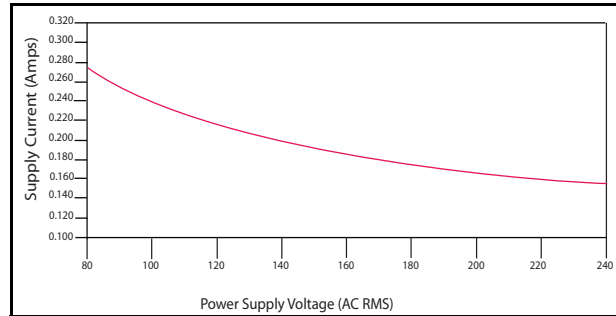
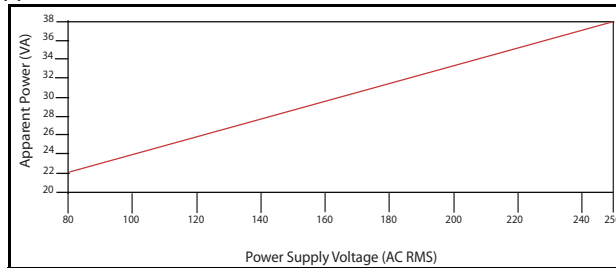

Figure A-2. Apparent Power



DC Supply Current Requirements

Units powered by 12-42 Vdc power supply may draw up to 1 amp of current steady state.

Figure A-3. DC Current Requirements

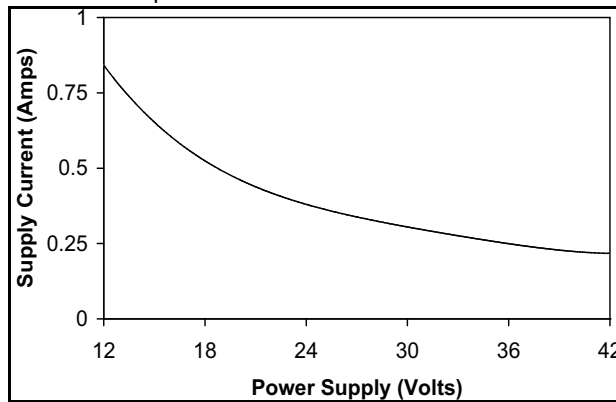

DC Load Limitations (Analog Output)

Maximum loop resistance is determined by the voltage level of the external power supply, as described by:

Figure 2. DC Load Limitations

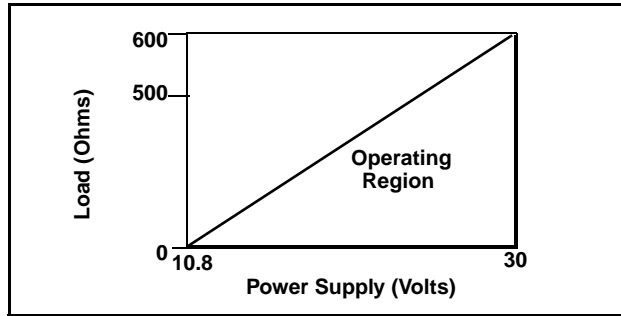

$$R_{\max} = 31.25 (V_{ps} - 10.8)$$

V_{ps} = Power Supply Voltage (Volts)
 R_{\max} = Maximum Loop Resistance (Ohms)

NOTE

HART Communication requires a minimum loop resistance of 250 ohms.

Power Consumption

10 watts maximum

Switch-on current

AC: Maximum 26 A (< 5 ms) at 250 Vac

DC: Maximum 30 A (< 5 ms) at 42 Vdc

Ambient Temperature Limits

Operating

-58 to 165 °F (-50 to 74 °C) without local operator interface

13 to 149 °F (-25 to 65 °C) with local operator interface

Storage

-40 to 185 °F (-40 to 85 °C)

-22 to 176 °F (-30 to 80 °C) with local operator interface

Humidity Limits

0-100% RH to 150 °F (65 °C)

Enclosure Rating

NEMA 4X CSA Type 4X, IEC 60529, IP66 (transmitter)

Transient Protection Rating

The 8732E has built in transient protection that conforms to EN 61000-4-4 for burst currents and 61000-4-5 for surge currents. For CE testing the transmitter is compliant with IEC 611185-2.2000 Class 3 which is up to 2 kV and up to 2 kA protection.

Output Signals

Analog Output Adjustment⁽¹⁾

4–20 mA, switch-selectable as internally or externally powered 10 to 30 Vdc; 0 to 600 Ω load.

Engineering units—lower and upper range values are user-selectable.

Output automatically scaled to provide 4 mA at lower range value and 20 mA at upper range value. Full scale continuously adjustable between -39 and 39 ft/s (-12 to 12 m/sec), 1 ft/s (0.3 m/s) minimum span.

HART Communications, digital flow signal, superimposed on 4–20 mA signal, available for control system interface. 250 Ω required for HART communications.

Scalable Frequency Adjustment⁽¹⁾

0-10,000 Hz, switch-selectable as internally or externally powered 10 to 30 Vdc, transistor switch closure up to 5.75 W. Pulse value can be set to equal desired volume in selected engineering units. Pulse width adjustable from 0.5 to 100 m/s. Local operator interface automatically calculates and displays maximum allowable output frequency.

(1) For transmitters with intrinsically safe outputs, power must be supplied externally.

Optional Digital Output Function (AX option)

Externally powered at 5 to 24 Vdc, transistor switch closure up to 3 W to indicate either:

Reverse Flow:

Activates switch closure output when reverse flow is detected. The reverse flow rate is displayed.

Zero Flow:

Activates switch closure output when flow goes to 0 ft/s.

Empty Pipe ⁽¹⁾:

Activates switch closure output when empty pipe is detected.

Transmitter Fault⁽¹⁾:

Activates switch closure output when a transmitter fault is detected.

Flow Limits (2):

Activates switch closure output when the transmitter measures a flow rate that meets the conditions established for this alert. There are two independent flow limit alerts that can be configured as discrete outputs.

Totalizer Limit:

Activates switch closure output when the transmitter measures a total flow that meets the conditions established for this alert.

Diagnostic Status:

Activates switch closure output when the transmitter detects a condition that meets the configured criteria of this output.

Optional Digital Input Function (AX option)

Externally powered at 5 to 24 Vdc, transistor switch closure up to 3 W to indicate either:

Net Total Reset:

Resets the net totalizer value to zero.

Positive Zero Return (PZR):

Forces outputs of the transmitter to zero flow.
Activated by applying a contact closure.

Security Lockout

Security lockout switch on the electronics board can be set to deactivate all LOI and HART-based communicator functions to protect configuration variables from unwanted or accidental change.

8732 LOI Lockout

All optical switches on the display can be locked locally from the display layout configuration screen by holding the upper right optical switch for 10 seconds. The display can be reactivated holding the same switch for 10 seconds.

(1) Available on the 8732E HART in August 2010.

Output Testing

Analog Output Test

Transmitter may be commanded to supply a specified current between 3.5 and 23 mA.

Pulse Output Test

Transmitter may be commanded to supply a specified frequency between 1 and 10,000 Hz.

Turn-on Time

5 minutes to rated accuracy from power up; 5 seconds from power interruption.

Start-up Time

50 ms from zero flow.

Low Flow Cutoff

Adjustable between 0.01 and 38.37 ft/s (0.003 and 11.7 m/s). Below selected value, output is driven to the zero flow rate signal level.

Overrange Capability

Signal output will remain linear until 110% of upper range value or 44 ft/s (13 m/s). The signal output will remain constant above these values. Out of range message displayed on LOI and the Field Communicator.

Damping

Adjustable between 0 and 256 seconds.

Sensor Compensation

Rosemount sensors are flow-calibrated and assigned a calibration factor at the factory. The calibration factor is entered into the transmitter, enabling interchangeability of sensors without calculations or a compromise in standard accuracy.

8732 transmitters and other manufacturer's sensors can be calibrated at known process conditions or at the Rosemount NIST-Traceable Flow Facility. Transmitters calibrated on site require a two-step procedure to match a known flow rate. This procedure can be found in "Universal Trim" on page 4-32.

Diagnostics

Basic

- Self test
- Transmitter faults
- Analog output test
- Pulse output test
- Tunable empty pipe
- Reverse flow
- Coil circuit fault
- Electronics temperature

Advanced (DA1 Suite)
 Ground/wiring fault
 High process noise
 Coated electrode detection

Advanced (DA2 Suite)
 Smart Meter Verification (8714i)
 4-20 mA loop verification

PERFORMANCE SPECIFICATIONS

(System specifications are given using the frequency output and with the unit at reference conditions.)

Accuracy

Includes the combined effects of linearity, hysteresis, repeatability, and calibration uncertainty.

Rosemount 8732 with 8705/8707 Sensor:

Standard system accuracy is $\pm 0.25\%$ of rate ± 1.0 mm/sec from 0.04 to 6 ft/s (0.01 to 2 m/s); above 6 ft/s (2 m/s), the system has an accuracy of $\pm 0.25\%$ of rate ± 1.5 mm/sec.

Optional high accuracy is $\pm 0.15\%$ of rate ± 1.0 mm/sec from 0.04 to 13 ft/s (0.01 to 4 m/s); above 13 ft/s (4 m/s), the system has an accuracy of $\pm 0.18\%$ of rate.⁽¹⁾

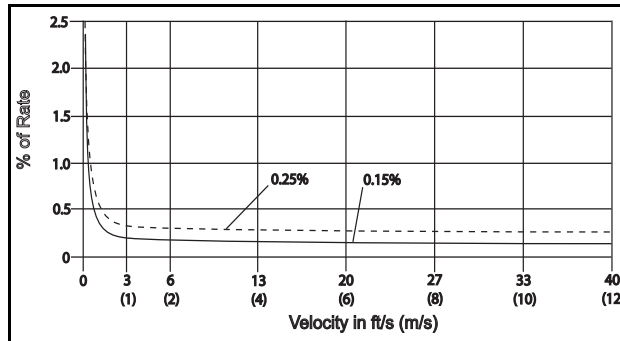

Rosemount 8732 with 8711 Sensor:

Standard system accuracy is $\pm 0.25\%$ of rate ± 2.0 mm/sec from 0.04 to 39 ft/s (0.01 to 12 m/s).

Optional high accuracy is $\pm 0.15\%$ of rate ± 1.0 mm/sec from 0.04 to 13 ft/s (0.01 to 4 m/s); above 13 ft/s (4 m/s), the system has an accuracy of $\pm 0.18\%$ of rate.

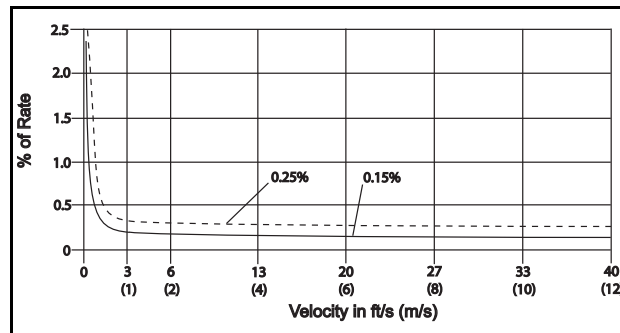

(1) For Sensor sizes greater than 12 in. (300 mm) the high accuracy is $\pm 0.25\%$ of rate from 3 to 39 ft/sec (1 to 12 m/sec).

Rosemount 8732 with 8721 Sensor:

Standard system accuracy is $\pm 0.5\%$ of rate from 1 to 39 ft/s (0.3 to 12 m/s); between 0.04 and 1.0 ft/s (0.01 and 0.3 m/s), the system has an accuracy of ± 0.005 ft/s (0.0015 m/s).

Optional high accuracy is $\pm 0.25\%$ of rate from 3 to 39 ft/s (1 to 12 m/s).

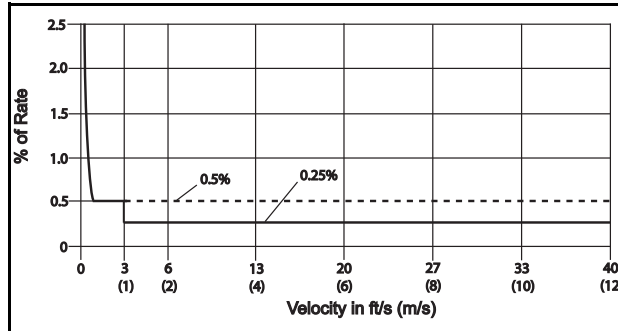

Rosemount 8732 with Legacy 8705 Sensors:

Standard system accuracy is $\pm 0.5\%$ of rate from 1 to 39 ft/s (0.3 to 12 m/s); between 0.04 and 1.0 ft/s (0.01 and 0.3 m/s), the system has an accuracy of ± 0.005 ft/s (0.0015 m/s).

Rosemount 8732 with Legacy 8711 Sensors:

Standard system accuracy is $\pm 0.5\%$ of rate from 3 to 39 ft/s (1 to 12 m/s); between 0.04 and 3.0 ft/s (0.01 and 1 m/s), the system has an accuracy of ± 0.015 ft/s (0.005 m/s).

Rosemount 8732 with Other Manufacturers' Sensors:

When calibrated in the Rosemount Flow Facility, system accuracies as good as 0.5% of rate can be attained.

There is no accuracy specification for other manufacturers' sensors calibrated in the process line.

Analog Output Effect

Analog output has the same accuracy as frequency output plus an additional $\pm 4\mu\text{A}$.

Vibration Effect

IEC 60770-1

Repeatability

$\pm 0.1\%$ of reading

Response Time (Analog Output)

50 ms maximum response time to step change in input

Stability

$\pm 0.1\%$ of rate over six months

Ambient Temperature Effect

$\pm 0.25\%$ change over operating temperature range

PHYSICAL SPECIFICATIONS

EMC Compliance

EN61326-1: 2006 (Industrial) electromagnetic compatibility (EMC) for process and laboratory apparatus.

Materials of Construction

Housing

Low copper aluminum, Type 4X and IEC 60529 IP66

Pollution Degree 2

Optional 316 Stainless Steel⁽¹⁾

Paint

Polyurethane

Cover Gasket

Rubber

Electrical Connections

Two 1/2–14 NPT connections provided on the transmitter housing (optional third connection available). PG13.5 and CM20 adapters are available. Screw terminals provided for all connections. Power wiring connected to transmitter only. Integrally mounted transmitters are factory wired to the sensor.

Line Power Fuses

90–250 Vac systems

2 amp, Quick-acting Bussman AGCI or equivalent

12–42 Vdc systems

3 amp, Quick-acting Bussman AGCI or equivalent

Transmitter Weight

Approximately 7 pounds (3.2 kg). Add 1 pound (0.5 kg) for Local Operator Interface (Option Code M4). Add 15.5 pounds (7 kg) for Stainless Steel housing.

(1) Remote mount only

Appendix B Approval Information

| | |
|--|----------|
| Product Certifications | page B-1 |
| Approved Manufacturing Locations | page B-1 |
| European Directive Information | page B-1 |
| Hazardous Locations Product Approvals Offering | page B-4 |
| Hazardous Location Certifications | page B-8 |

PRODUCT CERTIFICATIONS

Approved Manufacturing Locations

Rosemount Inc. — Eden Prairie, Minnesota, USA
Fisher-Rosemount Tecnologias de Flujo, S.A. de C.V. — Chihuahua Mexico
Emerson Process Management Flow — Ede, The Netherlands
Asia Flow Technologies Center — Nanjing, China

EUROPEAN DIRECTIVE INFORMATION

The EC declaration of conformity for all applicable European directives for this product can be found on our website at www.rosemount.com. A hard copy may be obtained by contacting your local sales office.

ATEX Directive

Rosemount Inc. complies with the ATEX Directive.

Type n protection type in accordance with EN50 021



- Closing of entries in the device must be carried out using the appropriate EEx e or EEx n metal cable gland and metal blanking plug or any appropriate ATEX approved cable gland and blanking plug with IP66 rating certified by an EU approved certification body.

For Rosemount 8732E transmitters:

Complies with Essential Health and Safety Requirements:

- EN 60079-0: 2006
- EN 60079-1: 2007
- EN 60079-7: 2007
- EN 60079-11: 2007
- EN 60079-15: 2005
- EN 61241-0: 2004
- EN 61241-1: 2006

Rosemount 8732

European Pressure Equipment Directive (PED) (97/23/EC)

For Rosemount 8712E transmitters:

Complies with Essential Health and Safety Requirements:
EN 60079-15: 2003

For Rosemount 8700 Series Sensors:

Complies with Essential Health and Safety Requirements:
EN 61241-0: 2006
EN 61241-1: 2004

Rosemount 8705 and 8707 Magnetic Flowmeter sensors in line size and flange combinations:

Line Size: 1½ in. - 24 in. with all DIN flanges and ANSI 150 and ANSI 300 flanges. Also available with ANSI 600 flanges in limited line sizes.
Line Size: 30 in. - 36 in. with AWWA 125 flanges
QS Certificate of Assessment - EC No. PED-H-100
Module H Conformity Assessment

Rosemount 8711 Magnetic Flowmeter Sensors

Line Sizes: 1.5, 2, 3, 4, 6, and 8 in.

QS Certificate of Assessment - EC No. PED-H-100
Module H Conformity Assessment

Rosemount 8721 Sanitary Magmeter Sensors in line sizes of 1½ in. and larger:

Module A Conformity Assessment

All other Rosemount 8705/8707/8711/8721 Sensors —

**in line sizes of 1 in. and less:
Sound Engineering Practice**

Sensors that are SEP are outside the scope of PED and cannot be marked for compliance with PED.

Mandatory CE-marking for sensors in accordance with Article 15 of the PED can be found on the sensor body (CE 0575).

Sensor category I is assessed for conformity per module A procedures.

Sensor categories II – III, use module H for conformity assessment procedures.

Electro Magnetic Compatibility (EMC) (2004/108/EC)

Model 8732E, 8712E, and 8712D EN 61326: 2006

Installed signal wiring should not be run together and should not be in the same cable tray as AC power wiring.

Device must be properly grounded or earthed according to local electric codes.

Rosemount combination cable model number
08712-0752-0001 (ft) or 08712-0752-0003 (m) is required to be used to meet EMC requirements.

**Low Voltage Directive
(2006/95/EC)**

Model 8732E, 8712E, and 8712D - EN 61010 -1: 2001

**Other important
guidelines**

Only use new, original parts.

To prevent the process medium escaping, do not unscrew or remove process flange bolts, adapter bolts or bleed screws during operation.

Maintenance shall only be done by qualified personnel.

CE CE Marking

Compliance with all applicable European Union Directives. (Note: CE Marking is not available on Rosemount 8712H).

IECEX Certificates

C-Tick Marking

Rosemount Inc. complies with the following IEC Requirements.

For Rosemount 8732E transmitters:

IEC 60079-0: 2004

IEC 60079-0: 2007

IEC 60079-1: 2007

IEC 60079-11: 2006

IEC 60079-15: 2005

IEC 60079-7: 2006

IEC 61241-0: 2004

IEC 61241-1: 2004

For Rosemount 8712E transmitters:

IEC 60079-0: 2004

IEC 60079-15: 2005-03

Rosemount 8732

HAZARDOUS LOCATIONS PRODUCT APPROVALS OFFERING

The Rosemount 8700 Series Magnetic Flowmeters offer many different hazardous locations certifications. The table below provides an overview of the available hazardous area approval options. Equivalent hazardous locations certifications for sensor and transmitter must match in integrally mounted magnetic flowmeter systems. Remote mounted magnetic flowmeter systems do not require matched hazardous location certifications. For complete information about the hazardous area approval codes listed, see Hazardous Location Certifications starting on page B-8.

Table 1. Factory Mutual (FM) Approvals Offering

| | Transmitter | 8732E | | | 8712E ⁽¹⁾ | | | 8712H ⁽¹⁾ |
|---|----------------------|---|-------------------|------|----------------------|----------|------|----------------------|
| | Sensor | 8705 | 8707 | 8711 | 8705 | 8707 | 8711 | 8707 |
| Hazardous Area Approval Code | | | | | | | | |
| Non-Classified Locations | | | | | | | | |
| Transmitter | NA | NA | NA | NA | NA | NA | NA | N0 |
| Sensor | NA | N0 | NA | NA | NA | N0 | NA | N0 |
| Suitable for Class I, Division 1 | | | | | | | | |
| Explosion-Proof | | | | | | | | |
| Trans: Groups C, D T6 | E5 ⁽²⁾ | - | E5 | - | - | - | - | - |
| Sensor: Groups C, D T6 | E5 ⁽²⁾ | - | E5 | - | - | - | - | - |
| Explosion-Proof with Intrinsically Safe Output | | | | | | | | |
| Trans: Groups C, D T6 | E5 ⁽²⁾⁽³⁾ | - | E5 ⁽³⁾ | - | - | - | - | - |
| Sensor: Groups C, D T6 | E5 ⁽²⁾ | - | E5 | - | - | - | - | - |
| Suitable for Class I, Division 2 | | | | | | | | |
| Non-Flammable Fluids | | | | | | | | |
| Trans: Groups A,B,C,D T4 | N0 | N0 | N0 | N0 | N0 | N0 | N0 | N0 |
| Sensor: Groups A,B,C,D T5 | N0 | N0 ⁽⁴⁾ | N0 | N0 | N0 ⁽⁴⁾ | N0 | N0 | N0 ⁽⁴⁾ |
| Flammable Fluids | | | | | | | | |
| Trans: Groups A,B,C,D T4 | N5 | N5 | N5 | N5 | N5 | N5 | N5 | N5 |
| Sensor: Groups A,B,C,D T5 | N5 | N5 ⁽⁴⁾ | N5 | N5 | N5 ⁽⁴⁾ | N5 | N5 | N5 ⁽⁴⁾ |
| Non-Flammable Fluids with Intrinsically Safe Output | | | | | | | | |
| Trans: Groups A,B,C,D T4 | N0 ⁽³⁾ | N0 ⁽³⁾ | N0 ⁽³⁾ | - | - | - | - | - |
| Sensor: Groups A,B,C,D T5 | N0 | N0 ⁽⁴⁾ | N0 | - | - | - | - | - |
| Other Certifications | | Product Certification Code⁽⁵⁾ | | | | | | |
| Canadian Registration Number (CRN) | CR | CR | Standard | CR | CR | Standard | CR | CR |
| European Pressure Equipment Directive (PED) | PD | - | PD | PD | - | PD | - | - |
| NSF 61 Drinking Water ⁽⁶⁾ | DW | - | DW | DW | - | DW | - | - |

- (1) Remote Transmitter Only.
- (2) Available in line sizes 0.5 in. to 8 in. (15 mm to 200 mm) only.
- (3) For I.S. Output, Output Code B or F must be ordered.
- (4) 8707 Sensor has Temp Code - T3C.
- (5) Product Certification Codes are added to the Sensor model number only.
- (6) Only available with PTFE or Polyurethane Lining Material and 316L SST Electrodes.

Table 2. Canadian Standards Association (CSA) Approvals Offering

| Transmitter | 8732E | | | 8712E ⁽¹⁾ | | | 8712H ⁽¹⁾ | |
|---|--------|-------------------|----------|----------------------|-------------------|----------|----------------------|-------------------|
| | Sensor | 8705 | 8707 | 8711 | 8705 | 8707 | 8711 | 8707 |
| Hazardous Area Approval Code | | | | | | | | |
| Non-Classified Locations | | | | | | | | |
| Transmitter | NA | - | NA | NA | - | NA | - | - |
| Sensor | NA | - | NA | NA | - | NA | - | - |
| Suitable for Class I, Division 2 | | | | | | | | |
| Non-Flammable Fluids | | | | | | | | |
| Trans: Groups A,B,C,D T4 | N0 | N0 | N0 | N0 | N0 | N0 | N0 | N0 |
| Sensor: Groups A,B,C,D T5 | N0 | N0 ⁽²⁾ | N0 | N0 | N0 ⁽²⁾ | N0 | N0 ⁽²⁾ | N0 ⁽²⁾ |
| Other Certifications | | | | | | | | |
| Product Certification Code⁽³⁾ | | | | | | | | |
| Canadian Registration Number (CRN) | CR | CR | Standard | CR | CR | Standard | CR | CR |
| European Pressure Equipment Directive (PED) | PD | - | PD | PD | - | PD | - | - |
| NSF 61 Drinking Water ⁽⁴⁾ | DW | - | DW | DW | - | DW | - | - |

(1) Remote Transmitter Only.

(2) 8707 Sensor has Temp Code - T3C.

(3) Product Certification Codes are added to the Sensor model number only.

(4) Only available with PTFE or Polyurethane Lining Material and 316L SST Electrodes.

Rosemount 8732

Table 3. ATEX Approvals Offering

| Transmitter | 8732E | | 8712E ⁽¹⁾ | |
|---|-------------------|-------------------|----------------------|----------|
| | Sensor | 8705 | 8711 | 8705 |
| Hazardous Area Approval Code | | | | |
| Non-Hazardous | | | | |
| Trans: LVD and EMC | NA | NA | NA | NA |
| Sensor: LVD and EMC | NA | NA | NA | NA |
| Equipment Category 2 | | | | |
| Gas Group IIB | | | | |
| Trans: Ex d IIB T6 | ED | ED | - | - |
| Sensor: Ex e ia IIC T3...T6 | KD ⁽²⁾ | KD ⁽²⁾ | - | - |
| Gas Group IIC | | | | |
| Trans: Ex d IIC T6 | E1 | E1 | - | - |
| Sensor: Ex e ia IIC T3...T6 | E1 | E1 | - | - |
| Gas Group IIB with Intrinsically Safe Output | | | | |
| Trans: Ex de [ia] IIB T6 | ED ⁽³⁾ | ED ⁽³⁾ | - | - |
| Sensor: Ex e ia IIC T3...T6 | KD ⁽²⁾ | KD ⁽²⁾ | - | - |
| Gas Group IIC with Intrinsically Safe Output | | | | |
| Trans: Ex de [ia] IIC T6 | E1 ⁽³⁾ | E1 ⁽³⁾ | - | - |
| Sensor: Ex e ia IIC T3...T6 | E1 | E1 | - | - |
| Equipment Category 3 | | | | |
| Gas Group IIC | | | | |
| Trans: Ex nA nL IIC T4 | N1 | N1 | N1 | N1 |
| Sensor: Ex nA [L] IIC T3...T6 | N1 | N1 | N1 | N1 |
| Equipment Category 1 - Dust Environment | | | | |
| Dust Environment Only | | | | |
| Trans: Dust Ignition Proof | ND | ND | - | - |
| Sensor: Dust Ignition Proof | ND | ND | - | - |
| Other Certifications | | | | |
| Product Certification Code⁽⁴⁾ | | | | |
| Canadian Registration Number (CRN) | CR | Standard | CR | Standard |
| European Pressure Equipment Directive (PED) | PD | PD | PD | PD |
| NSF 61 Drinking Water ⁽⁵⁾ | DW | DW | DW | DW |

- (1) Remote Transmitter Only.
(2) With integral mount transmitter, approval is valid for Gas Group IIB.
(3) For I.S. Output, Output Code B or F must be ordered.
(4) Product Certification Codes are added to the Sensor model number only.
(5) Only available with PTFE or Polyurethane Lining Material and 316L SST Electrodes.

Table 4. IECEx Approvals Offering

| | Transmitter | 8732E ⁽¹⁾ | | 8712E | |
|--|-------------|---|-------------------|---|----------|
| | Sensor | 8705 | 8711 | 8705 | 8711 |
| Hazardous Area Approval Code | | | | | |
| Non-Hazardous | | | | | |
| Trans: Low Voltage and EMC | | NA | NA | NA | NA |
| Sensor: Low Voltage and EMC | | NA | NA | NA | NA |
| Suitable for Zone 1 | | | | | |
| Gas Group IIB | | | | | |
| Trans: Ex d IIB T6 | | EF | EF | | |
| Gas Group IIC | | | | | |
| Trans: Ex d IIC T6 | | E7 | E7 | | |
| Gas Group IIB with Intrinsically Safe Output | | | | | |
| Trans: Ex de [ia] IIB T6 | | EF ⁽²⁾ | EF ⁽³⁾ | | |
| Gas Group IIC with Intrinsically Safe Output | | | | | |
| Trans: Ex de [ia] IIC T6 | | E1 ⁽³⁾ | E1 ⁽³⁾ | | |
| Suitable for Zone 2 | | | | | |
| Gas Group IIC | | | | | |
| Trans: Ex nA nL IIC T4 | | N7 | N7 | N7 | N7 |
| Suitable for Zone 20 | | | | | |
| Dust Environment Only | | | | | |
| Trans: Dust Ignition Proof | | NF | NF | | |
| Other Certifications | | Product Certification Code⁽³⁾ | | Product Certification Code⁽⁴⁾ | |
| Canadian Registration Number (CRN) | | CR | Standard | CR | Standard |
| European Pressure Equipment Directive (PED) | | PD | PD | PD | PD |
| NSF 61 Drinking Water ⁽⁵⁾ | | DW | DW | DW | DW |

- (1) Available in remote mount configuration only. Requires equivalent ATEX approval on the sensor.
- (2) For I.S. Output, Output Code B or F must be ordered.
- (3) Product Certification Codes are added to the Sensor model number only.
- (4) Product Certification Codes are added to the Sensor model number only.
- (5) Only available with PTFE or Polyurethane Lining Material and 316L SST Electrodes.

HAZARDOUS LOCATION CERTIFICATIONS

Equivalent Hazardous Location Certifications for sensor and transmitter must match in integrally-mounted magnetic flowmeter systems. Remote-mounted systems do not require matched hazardous location certification option codes.

North American Certifications Factory Mutual (FM)

NOTE

For intrinsically safe (IS) outputs on the 8732E output option code B, F, or P must be selected.

IS outputs for Class I, Division 1, Groups A, B, C, D.

Temp Code – T4 at 60 °C

NOTE

For the 8732E transmitters with a local operator interface (LOI), the lower ambient temperature limit is -20 °C.

N0 Division 2 Approval (All transmitters)

Reference Rosemount Control Drawing 08732-1052 (8732E).

Class I, Division 2, Groups A, B, C, D

Temp Codes – T4 (8712 at 40 °C),

T4 (8732 at 60 °C: $-50\text{ °C} \leq T_a \leq 60\text{ °C}$)

Dust-ignition proof Class II/III, Division 1, Groups E, F, G

Temp Codes – T4 (8712 at 40 °C), T5 (8732 at 60 °C), T6

Enclosure Type 4X

N5 Division 2 Approval (All Transmitters)

For sensors with IS electrodes only

Reference Rosemount Control Drawing 08732-1052 (8732E).

Class I, Division 2, Groups A, B, C, D

Temp Codes – T4 (8712 at 40 °C)

T4 (8732 at 60 °C: $-50\text{ °C} \leq T_a \leq 60\text{ °C}$)

Dust-ignition proof Class II/III, Division 1, Groups E, F, G

Temp Codes – T4 (8712 at 40 °C), T5 (8732 at 60 °C),

Enclosure Type 4X

E5 Explosion-Proof Approval (8732 only)

Reference Rosemount Control Drawing 08732-1052

Explosion-Proof for Class I, Division 1, Groups C, D

Temp Code – T6 at 60 °C

Dust-ignition proof Class II/III, Division 1, Groups E, F, G

Temp Code – T5 at 60 °C

Class I, Division 2, Groups A, B, C, D

Temp Codes – T4 at 60 °C

Enclosure Type 4X

Canadian Standards Association (CSA)

NOTE

For intrinsically safe (IS) outputs on the 8732E output option code B, F, or P must be selected.

IS outputs for Class I, Division 1, Groups A, B, C, D.

Temp Code – T4 at 60 °C

N0 Division 2 Approval

Reference Rosemount Control Drawing 08732-1051
(8732E only)

Class I, Division 2, Groups A, B, C, D

Temp Codes – T4 (8732 at 60 °C: $-50\text{ °C} \leq T_a \leq 60\text{ °C}$),

Dust-ignition proof Class II/III, Division 1, Groups E, F, G

Temp Codes – T4 (8712 at 40 °C), T5 (8732 at 60 °C)

Enclosure Type 4X

European Certifications

NOTE

For intrinsically safe (IS) outputs on the 8732E output option code B, F, or P must be selected.

IS outputs for Ex de [ia] IIB or IIC T6

E1 ATEX Flameproof

8732 - Certificate No.: KEMA 07ATEX0073 X  II 2G

Ex de IIC or Ex de [ia] IIC T6 ($-50\text{ °C} \leq T_a \leq +60\text{ °C}$)

with LOI ($-20\text{ °C} \leq T_a \leq +60\text{ °C}$)

$V_{\max} = 250\text{ Vac}$ or 42 Vdc

CE 0575

ED ATEX Flameproof

8732 - Certificate No.: KEMA 07ATEX0073 X  II 2G

Ex de IIB or Ex de [ia] IIB T6 ($-50\text{ °C} \leq T_a \leq +60\text{ °C}$)

with LOI ($-20\text{ °C} \leq T_a \leq +60\text{ °C}$)

$V_{\max} = 250\text{ Vac}$ or 42 Vdc

CE 0575

ND ATEX Dust

8732 - Certificate No.: KEMA 06ATEX0006

Ex tD A20 IP66 T 100 °C  II 1D

With IS: [Ex ia] IIC Ex Symbol II⁽¹⁾G

Amb. Temp. Limits: ($-20\text{ °C} \leq T_a \leq +65\text{ °C}$)

$V_{\max} = 250\text{ Vac}$ or 42 Vdc

CE 0575

SPECIAL CONDITIONS FOR SAFE USE

(KEMA 07ATEX0073 X):

If the Rosemount 8732 Flow Transmitter is used integrally with the Rosemount 8705 or 8711 Sensors, it shall be assured that the mechanical contact areas of the Sensor and Flow Transmitter comply with the requirements for flat joints according to standard EN/IEC 60079-1 clause 5.2.

The relation between ambient temperature, process temperature, and temperature class is to be taken from **Table 6**.

The electrical data is to be taken from **Table 5**.

If the Rosemount 8732 Flow Transmitter is used integrally with the Junction Box, it shall be assured that the mechanical contact areas of the Junction Box and Flow Transmitter comply with the requirements for flanged joints. Contact Rosemount Inc. for requirements and dimensions of Flanged Joints.

INSTALLATION INSTRUCTIONS:

The cable and conduit entry devices and blanking elements shall be of a certified flameproof type, suitable for the conditions of use and correctly installed. With the use of conduit, a certified stopping box shall be provided immediately to the entrance of the enclosure.

(1) *Max surface temperature is 40 °C above the ambient temperature conditions. $T_{\max} = 100\text{ °C}$*

INSTALLATION INSTRUCTIONS:

The cable and conduit entry devices and the closing elements shall be of a certified increased safety type, suitable for the conditions of use and correctly installed.

At ambient temperatures above 50 °C, the flow meter shall be used with heat resistant cables with a temperature rating of at least 90 °C.

A Junction Box in type of explosion protection increased safety "e" may be attached to the base of the Rosemount 8732E Flow Transmitter, permitting remote mounting of the Rosemount 8705 and 8711 Sensors.

The Junction Box is classified as II 2 G Ex e IIB T6 and certified under KEMA 07ATEX0073 X and KEMA 03ATEX2052X.

N1 ATEX Type n

8712E - ATEX Certificate No: BASEEFA 05ATEX0170X

EEx nA nL IIC T4 (Ta = -40 °C to + 60 °C)

V_{max} = 42 Vdc

CE 0575

SPECIAL CONDITIONS FOR SAFE USE (X)

The apparatus is not capable of withstanding the 500 V insulation test required by Clause 6.8.1 of EN 60079-15: 2005. This must be taken into account when installing the apparatus.

8732 HART

ATEX Certificate No: BASEEFA 07ATEX0203X  II 3G

Ex nA nL IIC T4 (-50 °C ≤ Ta ≤ + 60 °C)

with LOI (-20 °C ≤ Ta ≤ + 60 °C)

V_{max} = 42 Vdc

CE 0575

8732 digital fieldbus

ATEX Certificate No: BASEEFA 07ATEX0203X  II 3(1)G

Ex nA nL [ia] IIC T4 (-50 °C ≤ Ta ≤ + 60 °C)

with LOI (-20 °C ≤ Ta ≤ + 60 °C)

V_{max} = 42 Vdc

CE 0575

SPECIAL CONDITIONS FOR SAFE USE (X)

The apparatus is not capable of withstanding the 500 V insulation test required by Clause 6.8.1 of EN 60079-15: 2005. This must be taken into account when installing the apparatus.

IECEX

NOTE

For intrinsically safe (IS) outputs on the 8732E output option code B, F, or P must be selected.

IS outputs for Ex [ia] or IIC

E7 IECEx Flameproof

8732 - Certificate No.: KEM 07.0038X

Ex de IIC T6 Gb or Ex de [ia Ga] IIC T6 Gb

(-50 °C ≤ Ta ≤ +60 °C)

with LOI (-20 °C ≤ Ta ≤ +60 °C)

V_{max} = 250 Vac or 42 Vdc

EF IECEx Flameproof

8732 - Certificate No.: KEM 07.0038X

Ex de IIB T6 Gb or Ex de [ia IIC Ga] IIB T6 Gb

(-50 °C ≤ Ta ≤ +60 °C)

with LOI (-20 °C ≤ Ta ≤ +60 °C)

V_{max} = 250 Vac or 42 Vdc

NF IECEx Dust

8732 - Certificate No.: KEM 07.0038X
Ex tD A20 IP66 T 100 °C or
with IS: [Ex ia Ga] IIC
T6 (-50 °C ≤ Ta ≤ +60 °C)
with LOI (-20 °C ≤ Ta ≤ +60 °C)
V_{max} = 250 Vac or 42 Vdc

SPECIAL CONDITIONS FOR SAFE USE (KEM 07.0038X):

If the Rosemount 8732 Flow Transmitter is used integrally with the Rosemount 8705 or 8711 Sensors, it shall be assured that the mechanical contact areas of the Sensor and Flow Transmitter comply with the requirements for flat joints according to standard EN/IEC 60079-1 clause 5.2.

The relation between ambient temperature, process temperature, and temperature class is to be taken from **Table 6**.

The electrical data is to be taken from **Table 5**.

If the Rosemount 8732 Flow Transmitter is used integrally with the Junction Box, it shall be assured that the mechanical contact areas of the Junction Box and Flow Transmitter comply with the requirements for flanged joints according to standard EN/IEC 60079-1 clause 5.2.

INSTALLATION INSTRUCTIONS:

The cable and conduit entry devices and blanking elements shall be of a certified flameproof type, suitable for the conditions of use and correctly installed. With the use of conduit, a certified stopping box shall be provided immediately to the entrance of the enclosure.

N7 IECEx Type n

8712E - Certificate No: IECEx BAS 07.0036X
Ex nA nL IIC T4 (Ta = -40 °C to + 60 °C)
V_{max} = 42 Vdc

SPECIAL CONDITIONS FOR SAFE USE (X)

The apparatus is not capable of withstanding the 500 V insulation test required by Clause 6.8.1 of IEC 60079-15: 2005. This must be taken into account when installing the apparatus.

8732 HART

Certificate No: IECEx BAS 07.0062X
Ex nA nL IIC T4 (-50 °C ≤ Ta ≤ +60 °C)
with LOI (-20 °C ≤ Ta ≤ +60 °C)
V_{max} = 42 Vdc

8732 digital fieldbus

Certificate No: IECEx BAS 07.0062X
Ex nA nL [ia] IIC T4 (-50 °C ≤ Ta ≤ +60 °C)
with LOI (-20 °C ≤ Ta ≤ +60 °C)
V_{max} = 42 Vdc

SPECIAL CONDITIONS FOR SAFE USE (X)

The apparatus is not capable of withstanding the 500 V insulation test required by Clause 6.8.1 of EN 60079-15: 2005. This must be taken into account when installing the apparatus.

NEPSI - China

NOTE

For intrinsically safe (IS) outputs on the 8732E output option code B, F, or P must be selected.

IS outputs for Ex de [ia] IIB or IIC T6

E3 NEPSI Flameproof

8732 - Certificate No.: GYJ071438X
Ex de IIC or Ex de [ia] IIC T6 (-50 °C ≤ Ta ≤ +60 °C)
with LOI (-20 °C ≤ Ta ≤ +60 °C)
V_{max} = 250 Vac or 42 Vdc

EP NEPSI Flameproof

8732 - Certificate No.: GYJ071438X
Ex de IIB or Ex de [ia] IIB T6 (-50 °C ≤ Ta ≤ +60 °C)
with LOI (-20 °C ≤ Ta ≤ +60 °C)
V_{max} = 250 Vac or 42 Vdc

InMetro - Brazil

NOTE

For intrinsically safe (IS) outputs on the 8732E output option code B, F, or P must be selected.

IS outputs for Ex de [ia] IIB or IIC T6

E2 InMetro Flameproof

8732 - Certificate No.: NCC 5030/08
BR-Ex de IIC or BR-Ex de [ia] IIC T6 (-50 °C ≤ Ta ≤ +60 °C)
with LOI (-20 °C ≤ Ta ≤ +60 °C)
V_{max} = 250 Vac or 42 Vdc

EB InMetro Flameproof

8732 - Certificate No.: NCC 5030/08
BR-Ex de IIB or BR-Ex de [ia] IIB T6 (-50 °C ≤ Ta ≤ +60 °C)
with LOI (-20 °C ≤ Ta ≤ +60 °C)
V_{max} = 250 Vac or 42 Vdc

KOSHA - Korea

NOTE

For intrinsically safe (IS) outputs on the 8732E output option code B, F, or P must be selected.

IS outputs for Ex de [ia] IIB or IIC T6

E9 KOSHA Flameproof

8732 - Certificate No.: 2008-2094-Q1X
Ex de IIC or Ex de [ia] IIC T6 (-50 °C ≤ Ta ≤ +60 °C)
with LOI (-20 °C ≤ Ta ≤ +60 °C)
V_{max} = 250 Vac or 42 Vdc

EK KOSHA Flameproof

8732 - Certificate No.: 2008-2094-Q1X
Ex de IIB or Ex de [ia] IIB T6 (-50 °C ≤ Ta ≤ +60 °C)
with LOI (-20 °C ≤ Ta ≤ +60 °C)
V_{max} = 250 Vac or 42 Vdc

Sensor Approval Information

North American Certifications

Factory Mutual (FM)

- N0 Division 2 Approval for Non-Flammable Fluids (All Sensors)**
Class I, Division 2, Groups A, B, C, D
Temp Code – T5 (8705/8711 at 60 °C)
Temp Code – T3C (8707 at 60 °C)
Dust-Ignition proof Class II/III, Division 1, Groups E, F, G
Temp Code – T6 (8705/8711 at 60 °C)
Temp Code – T3C (8707 at 60 °C)
Enclosure Type 4X
- N0 for 8721 Hygienic Sensor**
Factory Mutual (FM) Ordinary Location;
CE Marking; 3-A Symbol Authorization #1222;
EHEDG Type EL
- N5 Division 2 Approval for Flammable Fluids (All Sensors)**
Class I, Division 2, Groups A, B, C, D
Temp Code – T5 (8705/8711 at 60 °C)
Temp Code – T3C (8707 at 60 °C)
Dust-Ignition proof Class II/III, Division 1, Groups E, F, G
Temp Code – T6 (8705/8711 at 60 °C)
Temp Code – T3C (8707 at 60 °C)
Enclosure Type 4X
- E5 Explosion-Proof (8705 and 8711 Only)**
Explosion-Proof for Class I, Division 1, Groups C, D
Temp Code – T6 at 60 °C
Dust-Ignition proof Class II/III, Division 1, Groups E, F, G
Temp Code – T6 at 60 °C
Class I, Division 2, Groups A, B, C, D
Temp Code – T5 at 60 °C
Enclosure Type 4X

Canadian Standards Association (CSA)

- N0** Suitable for Class I, Division 2, Groups A, B, C, D
Temp Code – T5 (8705/8711 at 60 °C)
Temp Code – T3C (8707 at 60 °C)
Dust-Ignition proof Class II/III, Division 1, Groups E, F, G
Enclosure Type 4X
- N0 for 8721 Hygienic Sensor**
Canadian Standards Association (CSA) Ordinary Location;
CE Marking; 3-A Symbol Authorization #1222;
EHEDG Type EL

European Certifications

- ND** ATEX Dust Certificate No.: KEMA 06ATEX0006
 II 1D Ex tD A20 IP6x T105°C (-50 ≤ T_{amb} ≤ 65 °C)
CE 0575

INSTALLATION INSTRUCTIONS

The cable and conduit entry devices and blanking elements shall be of a certified IP6x type, suitable for the conditions of use and correctly installed. At maximum ambient temperatures or at process temperatures above 60 °C heat resistant cables with a temperature rating of at least 90 °C shall be used.

N1 ATEX Non-Sparking/Non-incendive

Certificate No: KEMA02ATEX1302X  II 3G
EEx nA [L] IIC T3... T6
Ambient Temperature Limits -20 to 65 °C

SPECIAL CONDITIONS FOR SAFE USE (X):

The relation between ambient temperature, process temperature, and temperature class is to be taken from Table 7. The electrical data is to be taken from Table 5.

E1, ATEX Increased Safety with IS Electrodes

KD Certificate No: KEMA03ATEX2052X  II 1/2G
EEx e ia IIC T3... T6 (Ta = -20 to +60 °C) (See Table 6)
CE 0575
V_{max} = 40 V

SPECIAL CONDITIONS FOR SAFE USE (X):

The relation between ambient temperature, process temperature, and temperature class is to be taken from Table 6. The electrical data is to be taken from Table 5.

INSTALLATION INSTRUCTIONS:

At ambient temperature above 50 °C, the flowmeter shall be used with heat resistant cables with a temperature rating of at least 90 °C.

A fuse with a rating of maximum 0,7 A according to IEC 60127-1 shall be included in the coil excitation circuit if the sensors are used with other flow transmitters (e.g. Rosemount 8712).

International Certifications

IECEX

NF IECEX Dust

Certificate Number: IECEX KEM 09.0078
Ex tD A20 IP6x T105 °C (-50 ≤ T_{amb} ≤ 65 °C)

INSTALLATION INSTRUCTIONS:

The cable and conduit entry devices and blanking elements shall be of a certified IP6x type, suitable for the conditions of use and correctly installed. At maximum ambient temperatures or at process temperatures above 60 °C heat resistant cables with a temperature rating of at least 90 °C shall be used.

NEPSI - China

E3, NEPSI Increased Safety with IS Electrodes

EP Certificate No: GYJ071438X
Ex e ia IIC T3... T6 (Ta = -20 to +60 °C) (See Table 6)
V_{max} = 40 V

InMetro - Brazil

E2, InMetro Increased Safety with IS Electrodes

EB Certificate No: NCC 5030/08
BR-Ex e ia IIC T3... T6 (Ta = -20 to +60 °C) (See Table 6)
V_{max} = 40 V

KOSHA - Korea

E9, KOSHA Increased Safety with IS Electrodes

EK Certificate No: 2005-2233-Q1X
Ex e ia IIC T3... T6 (Ta = -20 to +60 °C) (See Table 6)
V_{max} = 40 V

Table 5. Electrical Data

| Rosemount 8732 Flow Transmitter | |
|---------------------------------|---|
| Power supply: | 250 Vac, 1 A or 42 Vdc, 1 A, 20 W maximum |
| Pulsed output circuit: | 30 Vdc (pulsed), 0,25 A, 7,5 W maximum |
| 4-20 mA output circuit: | 30 Vdc, 30 mA, 900 mW maximum |
| Rosemount 8705 and 8711 Sensors | |
| Coil excitation circuit: | 40 V, 0,5 A, 20 W maximum |
| Electrode circuit: | in type of explosion protection intrinsic safety EEx ia IIC, $U_i = 5$ V, $I_i = 0,2$ mA, $P_i = 1$ mW, $U_m = 250$ V |

Table 6. Relation between ambient temperature, process temperature, and temperature class⁽¹⁾

| Meter Size (Inches) | Maximum Ambient Temperature | Maximum Process Temperature | Temperature Class |
|---------------------|-----------------------------|-----------------------------|-------------------|
| 1/2 | 149 °F (65 °C) | 239 °F (115 °C) | T3 |
| 1 | 149 °F (65 °C) | 248 °F (120 °C) | T3 |
| 1 | 95 °F (35 °C) | 95 °F (35 °C) | T4 |
| 1 1/2 | 149 °F (65 °C) | 257 °F (125 °C) | T3 |
| 1 1/2 | 122 °F (50 °C) | 140 °F (60 °C) | T4 |
| 2 | 149 °F (65 °C) | 257 °F (125 °C) | T3 |
| 2 | 149 °F (65 °C) | 167 °F (75 °C) | T4 |
| 2 | 104 °F (40 °C) | 104 °F (40 °C) | T5 |
| 3 - 4 | 149 °F (65 °C) | 266 °F (130 °C) | T3 |
| 3 - 4 | 149 °F (65 °C) | 194 °F (90 °C) | T4 |
| 3 - 4 | 131 °F (55 °C) | 131 °F (55 °C) | T5 |
| 3 - 4 | 104 °F (40 °C) | 104 °F (40 °C) | T6 |
| 6 | 149 °F (65 °C) | 275 °F (135 °C) | T3 |
| 6 | 149 °F (65 °C) | 230 °F (110 °C) | T4 |
| 6 | 149 °F (65 °C) | 167 °F (75 °C) | T5 |
| 6 | 140 °F (60 °C) | 140 °F (60 °C) | T6 |
| 8-60 | 149 °F (65 °C) | 284 °F (140 °C) | T3 |
| 8-60 | 149 °F (65 °C) | 239 °F (115 °C) | T4 |
| 8-60 | 149 °F (65 °C) | 176 °F (80 °C) | T5 |
| 8-60 | 149 °F (65 °C) | 149 °F (65 °C) | T6 |

(1) This table is applicable for the E1 and KD approval codes only.

Rosemount 8732

Table 7. Relation between the maximum ambient temperature, the maximum process temperature, and the temperature class⁽¹⁾

| Maximum Ambient Temperature | Maximum process temperature °F (°C) per temperature class | | | |
|-----------------------------|---|-----------------|----------------|----------------|
| | T3 | T4 | T5 | T6 |
| 0.5 in. sensor size | | | | |
| 149 °F (65 °C) | 296 °F (147 °C) | 138 °F (59 °C) | 53 °F (12 °C) | 17 °F (-8 °C) |
| 140 °F (60 °C) | 309 °F (154 °C) | 150 °F (66 °C) | 66 °F (19 °C) | 28 °F (-2 °C) |
| 131 °F (55 °C) | 321 °F (161 °C) | 163 °F (73 °C) | 78 °F (26 °C) | 41 °F (5 °C) |
| 122 °F (50 °C) | 334 °F (168 °C) | 176 °F (80 °C) | 89 °F (32 °C) | 53 °F (12 °C) |
| 113 °F (45 °C) | 347 °F (175 °C) | 188 °F (87 °C) | 102 °F (39 °C) | 66 °F (19 °C) |
| 104 °F (40 °C) | 350 °F (177 °C) | 199 °F (93 °C) | 114 °F (46 °C) | 78 °F (26 °C) |
| 95 °F (35 °C) | 350 °F (177 °C) | 212 °F (100 °C) | 127 °F (53 °C) | 89 °F (32 °C) |
| 86 °F (30 °C) | 350 °F (177 °C) | 224 °F (107 °C) | 138 °F (59 °C) | 102 °F (39 °C) |
| 77 °F (25 °C) | 350 °F (177 °C) | 237 °F (114 °C) | 150 °F (66 °C) | 114 °F (46 °C) |
| 68 °F (20 °C) | 350 °F (177 °C) | 248 °F (120 °C) | 163 °F (73 °C) | 127 °F (53 °C) |
| 1.0 in. sensor size | | | | |
| 149 °F (65 °C) | 318 °F (159 °C) | 158 °F (70 °C) | 71 °F (22 °C) | 33 °F (1 °C) |
| 140 °F (60 °C) | 330 °F (166 °C) | 170 °F (77 °C) | 84 °F (29 °C) | 46 °F (8 °C) |
| 131 °F (55 °C) | 343 °F (173 °C) | 183 °F (84 °C) | 96 °F (36 °C) | 59 °F (15 °C) |
| 122 °F (50 °C) | 351 °F (177 °C) | 195 °F (91 °C) | 109 °F (43 °C) | 71 °F (22 °C) |
| 113 °F (45 °C) | 350 °F (177 °C) | 206 °F (97 °C) | 122 °F (50 °C) | 84 °F (29 °C) |
| 104 °F (40 °C) | 350 °F (177 °C) | 219 °F (104 °C) | 134 °F (57 °C) | 96 °F (36 °C) |
| 95 °F (35 °C) | 350 °F (177 °C) | 231 °F (111 °C) | 145 °F (63 °C) | 109 °F (43 °C) |
| 86 °F (30 °C) | 350 °F (177 °C) | 244 °F (118 °C) | 158 °F (70 °C) | 122 °F (50 °C) |
| 77 °F (25 °C) | 350 °F (177 °C) | 257 °F (125 °C) | 170 °F (77 °C) | 134 °F (57 °C) |
| 68 °F (20 °C) | 350 °F (177 °C) | 269 °F (132 °C) | 183 °F (84 °C) | 145 °F (63 °C) |
| 1.5 in. sensor size | | | | |
| 149 °F (65 °C) | 296 °F (147 °C) | 159 °F (71 °C) | 87 °F (31 °C) | 55 °F (13 °C) |
| 140 °F (60 °C) | 307 °F (153 °C) | 170 °F (77 °C) | 96 °F (36 °C) | 66 °F (19 °C) |
| 131 °F (55 °C) | 318 °F (159 °C) | 181 °F (83 °C) | 107 °F (42 °C) | 77 °F (25 °C) |
| 122 °F (50 °C) | 329 °F (165 °C) | 192 °F (89 °C) | 118 °F (48 °C) | 87 °F (31 °C) |
| 113 °F (45 °C) | 339 °F (171 °C) | 203 °F (95 °C) | 129 °F (54 °C) | 96 °F (36 °C) |
| 104 °F (40 °C) | 350 °F (177 °C) | 213 °F (101 °C) | 140 °F (60 °C) | 107 °F (42 °C) |
| 95 °F (35 °C) | 350 °F (177 °C) | 222 °F (106 °C) | 150 °F (66 °C) | 118 °F (48 °C) |
| 86 °F (30 °C) | 350 °F (177 °C) | 233 °F (112 °C) | 159 °F (71 °C) | 129 °F (54 °C) |
| 77 °F (25 °C) | 350 °F (177 °C) | 244 °F (118 °C) | 170 °F (77 °C) | 140 °F (60 °C) |
| 68 °F (20 °C) | 350 °F (177 °C) | 255 °F (124 °C) | 181 °F (83 °C) | 150 °F (66 °C) |

Table 7. Relation between the maximum ambient temperature, the maximum process temperature, and the temperature class⁽¹⁾

| Maximum Ambient Temperature | Maximum process temperature °F (°C) per temperature class | | | |
|--------------------------------|---|-----------------|----------------|----------------|
| | T3 | T4 | T5 | T6 |
| 2.0 in. sensor size | | | | |
| 149 °F (65 °C) | 289 °F (143 °C) | 163 °F (73 °C) | 95 °F (35 °C) | 66 °F (19 °C) |
| 140 °F (60 °C) | 300 °F (149 °C) | 172 °F (78 °C) | 104 °F (40 °C) | 75 °F (24 °C) |
| 131 °F (55 °C) | 309 °F (154 °C) | 183 °F (84 °C) | 114 °F (46 °C) | 84 °F (29 °C) |
| 122 °F (50 °C) | 318 °F (159 °C) | 192 °F (89 °C) | 123 °F (51 °C) | 95 °F (35 °C) |
| 113 °F (45 °C) | 329 °F (165 °C) | 201 °F (94 °C) | 134 °F (57 °C) | 104 °F (40 °C) |
| 104 °F (40 °C) | 338 °F (170 °C) | 212 °F (100 °C) | 143 °F (62 °C) | 114 °F (46 °C) |
| 95 °F (35 °C) | 348 °F (176 °C) | 221 °F (105 °C) | 152 °F (67 °C) | 123 °F (51 °C) |
| 86 °F (30 °C) | 350 °F (177 °C) | 231 °F (111 °C) | 163 °F (73 °C) | 134 °F (57 °C) |
| 77 °F (25 °C) | 350 °F (177 °C) | 240 °F (116 °C) | 172 °F (78 °C) | 143 °F (62 °C) |
| 68 °F (20 °C) | 350 °F (177 °C) | 251 °F (122 °C) | 183 °F (84 °C) | 152 °F (67 °C) |
| 3 to 60 in. sensor size | | | | |
| 149 °F (65 °C) | 350 °F (177 °C) | 210 °F (99 °C) | 116 °F (47 °C) | 75 °F (24 °C) |
| 140 °F (60 °C) | 350 °F (177 °C) | 222 °F (106 °C) | 129 °F (54 °C) | 89 °F (32 °C) |
| 131 °F (55 °C) | 350 °F (177 °C) | 237 °F (114 °C) | 143 °F (62 °C) | 102 °F (39 °C) |
| 122 °F (50 °C) | 350 °F (177 °C) | 249 °F (121 °C) | 156 °F (69 °C) | 116 °F (47 °C) |
| 113 °F (45 °C) | 350 °F (177 °C) | 264 °F (129 °C) | 170 °F (77 °C) | 129 °F (54 °C) |
| 104 °F (40 °C) | 350 °F (177 °C) | 266 °F (130 °C) | 183 °F (84 °C) | 143 °F (62 °C) |
| 95 °F (35 °C) | 350 °F (177 °C) | 266 °F (130 °C) | 197 °F (92 °C) | 156 °F (69 °C) |
| 86 °F (30 °C) | 350 °F (177 °C) | 266 °F (130 °C) | 203 °F (95 °C) | 170 °F (77 °C) |
| 77 °F (25 °C) | 350 °F (177 °C) | 266 °F (130 °C) | 203 °F (95 °C) | 176 °F (80 °C) |
| 68 °F (20 °C) | 350 °F (177 °C) | 266 °F (130 °C) | 203 °F (95 °C) | 176 °F (80 °C) |

(1) This table is applicable for N1 option codes only.

Dimensional Drawings

Figure B-1. Rosemount 8732E Transmitter

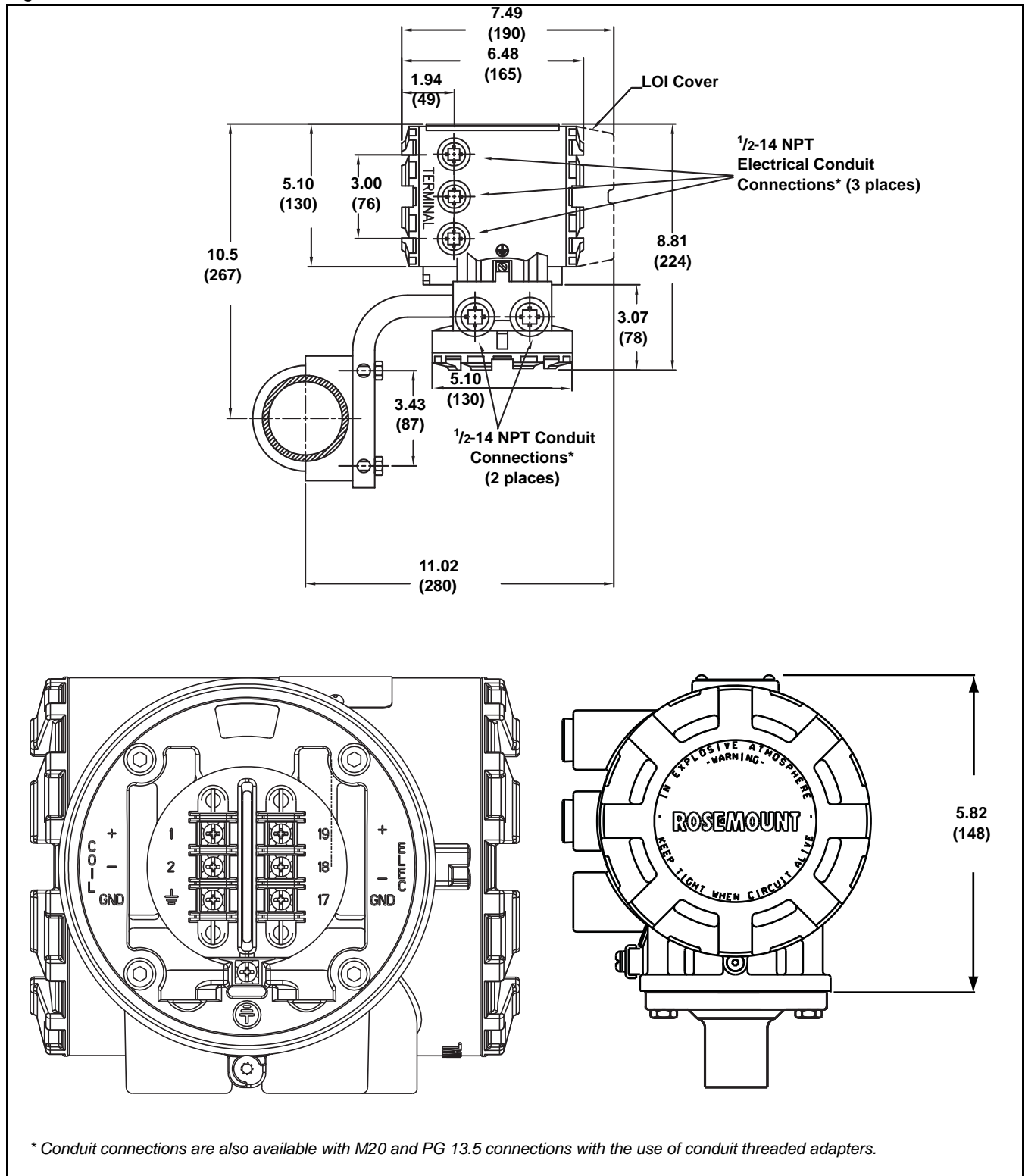

Figure B-2. ATEX Installation Slip-on Flanges - Low pressure ($P \leq \text{ANSI } 300\#$)

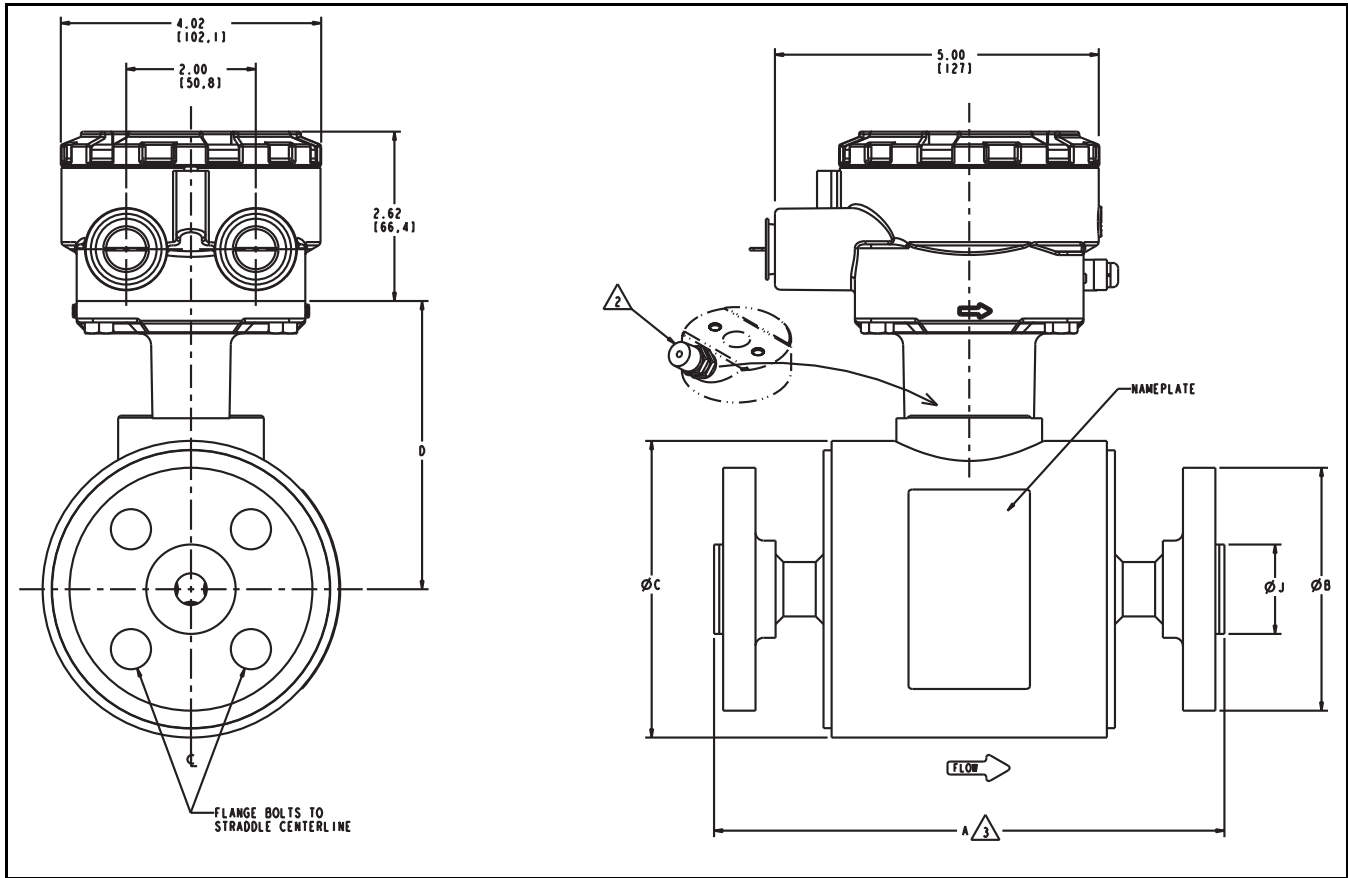

Table B-1. 0.5-in. through 2-in. Slip-on Flanges (mm)

| Size, Description | Overall Length | Dim "A" Poly | Body Dia. DIM "C" | CL to UMB DIM "D" | Liner Dia. on Face DIM "J" | Sensor Weight lbs. (kg) |
|------------------------------------|----------------|-----------------|----------------------|----------------------|----------------------------------|-------------------------------|
| | Dim "A" | | | | | |
| "0.5 (15) ANSI - 150#, SO / RF | 7.88 (200) | 7.88 (200) | 4.50 (114) | 4.41 (112) | 1.38 (35) | 15 (6.8) |
| "0.5 (15) ANSI - 300#, SO / RF | 7.88 (200) | 7.88 (200) | 4.50 (114) | 4.41 (112) | 1.38 (35) | 22 (10.0) |
| "0.5 (15) DIN - PN40, SO / RF | 7.88 (200) | 7.88 (200) | 4.50 (114) | 4.41 (112) | 1.77 (45) | 20 (9.1) |
| "0.5 (15) AUST. TABLE "D", SO / RF | 7.88 (200) | 7.88 (200) | 4.50 (114) | 4.41 (112) | 1.38 (35) | 15 (6.8) |
| "0.5 (15) AUST. TABLE "E", SO / RF | 7.88 (200) | 7.88 (200) | 4.50 (114) | 4.41 (112) | 1.38 (35) | 22 (10.0) |
| "0.5 (15) JIS - 10K, SO / RF | 7.88 (200) | 7.88 (200) | 4.50 (114) | 4.41 (112) | 2.01 (51) | 10 (4.5) |
| "0.5 (15) JIS - 20K, SO / RF | 7.88 (200) | 7.88 (200) | 4.50 (114) | 4.41 (112) | 2.01 (51) | 11 (4.7) |
| "1 (25) ANSI - 150#, SO / RF | 7.88 (200) | 7.88 (200) | 4.50 (114) | 4.41 (112) | 2.00 (51) | 18 (8.2) |
| "1 (25) ANSI - 300#, SO / RF | 7.88 (200) | 7.88 (200) | 4.50 (114) | 4.41 (112) | 2.00 (51) | 22 (10.0) |
| "1 (25) DIN - PN40, SO / RF | 7.88 (200) | 7.88 (200) | 4.50 (114) | 4.41 (112) | 2.88 (73) | 20 (9.1) |
| "1 (25) AUST. TABLE "D", SO / RF | 7.88 (200) | 7.88 (200) | 4.50 (114) | 4.41 (112) | 2.00 (51) | 18 (8.2) |
| "1 (25) AUST. TABLE "E", SO / RF | 7.88 (200) | 7.88 (200) | 4.50 (114) | 4.41 (112) | 2.00 (51) | 22 (10.0) |
| "1 (25) JIS - 10K, SO / RF | 7.88 (200) | 7.88 (200) | 4.50 (114) | 4.41 (112) | 2.64 (67) | 13 (5.9) |
| "1 (25) JIS - 20K, SO / RF | 7.88 (200) | 7.88 (200) | 4.50 (114) | 4.41 (112) | 2.64 (67) | 14 (6.4) |
| "1.5 (40) ANSI - 150#, SO / RF | 7.87 (200) | 7.88 (200) | 5.21 (132) | 4.82 (122) | 2.88 (73) | 22 (10.0) |
| "1.5 (40) ANSI - 300#, SO / RF | 7.87 (200) | 7.88 (200) | 5.21 (132) | 4.82 (122) | 2.88 (73) | 24 (10.9) |
| "1.5 (40) DIN - PN40, SO / RF | 7.87 (200) | 7.88 (200) | 5.21 (132) | 4.82 (122) | 3.46 (88) | 22 (10.0) |
| "1.5 (40) AUST. TABLE "D", SO / RF | 7.87 (200) | 7.88 (200) | 5.21 (132) | 4.82 (122) | 2.88 (73) | 22 (10.0) |
| "1.5 (40) AUST. TABLE "E", SO / RF | 7.87 (200) | 7.88 (200) | 5.21 (132) | 4.82 (122) | 2.88 (73) | 24 (10.9) |
| "1.5 (40) JIS - 10K, SO / RF | 7.87 (200) | 7.88 (200) | 5.21 (132) | 4.82 (122) | 3.19 (81) | 17 (7.5) |
| "1.5 (40) JIS - 20K, SO / RF | 7.87 (200) | 7.88 (200) | 5.21 (132) | 4.82 (122) | 3.19 (81) | 18 (8.2) |

Rosemount 8732

Table B-1. 0.5-in. through 2-in. Slip-on Flanges (mm)

| | | | | | | |
|----------------------------------|------------|------------|------------|------------|------------|-----------|
| "2 (50) ANSI - 150#, SO / RF | 7.87 (200) | 7.88 (200) | 5.21 (132) | 4.82 (122) | 3.62 (92) | 26 (11.8) |
| "2 (50) ANSI - 300#, SO / RF | 7.87 (200) | 7.88 (200) | 5.21 (132) | 4.82 (122) | 3.62 (92) | 28 (12.7) |
| "2 (50) DIN - PN40, SO / RF | 7.87 (200) | 7.88 (200) | 5.21 (132) | 4.82 (122) | 4.02 (102) | 26 (11.8) |
| "2 (50) AUST. TABLE "D", SO / RF | 7.87 (200) | 7.88 (200) | 5.21 (132) | 4.82 (122) | 3.62 (92) | 26 (11.8) |
| "2 (50) AUST. TABLE "E", SO / RF | 7.87 (200) | 7.88 (200) | 5.21 (132) | 4.82 (122) | 3.62 (92) | 28 (12.7) |
| "2 (50) JIS - 10K, SO / RF | 7.87 (200) | 7.88 (200) | 5.21 (132) | 4.82 (122) | 3.78 (96) | 19 (8.7) |
| "2 (50) JIS - 20K, SO / RF | 7.87 (200) | 7.88 (200) | 5.21 (132) | 4.82 (122) | 3.78 (96) | 19 (8.7) |

Figure B-3. 3-in. through 36-in. Slip-on Flanges - Low pressure ($P \leq$ ANSI 300#)

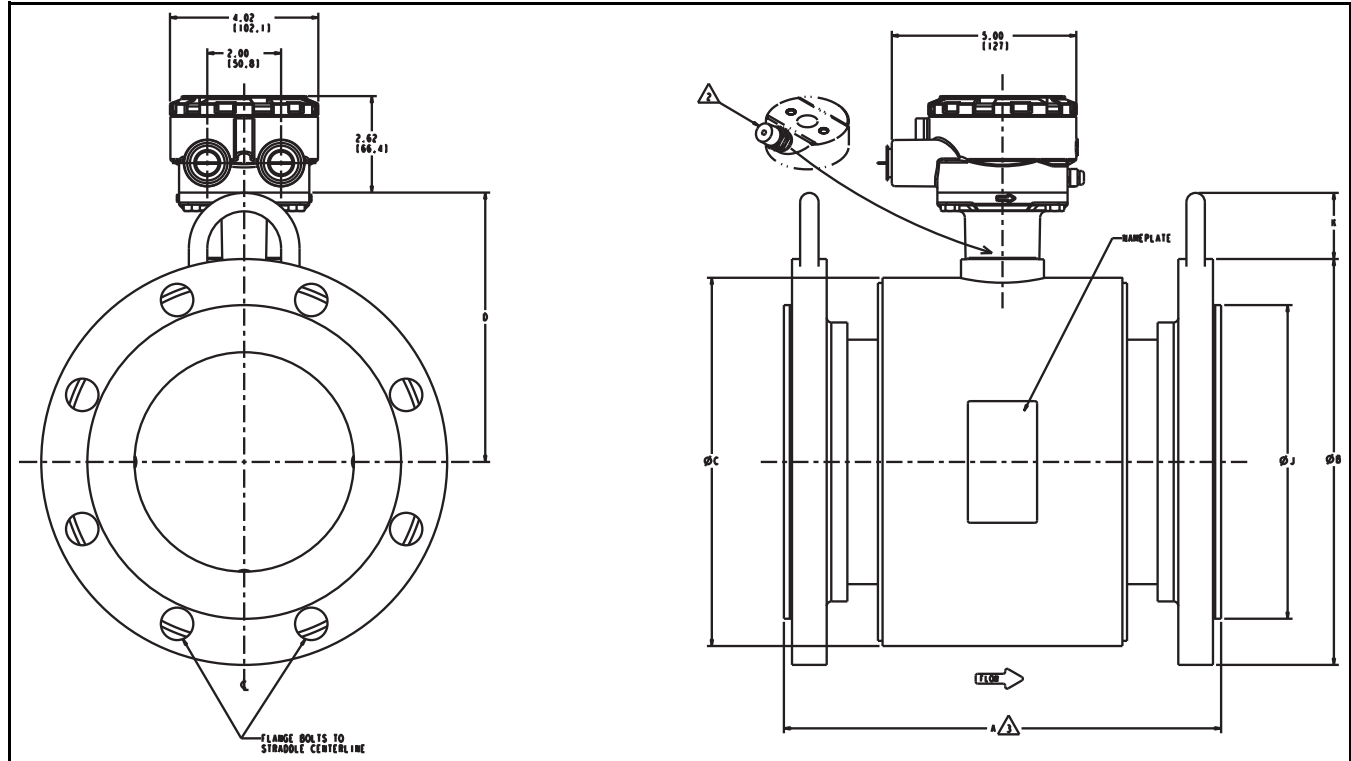

Table B-2. 3-in. through 36-in. Slip-on Flanges (mm)

| Size, Description | Overall Length | Dim "A" Poly | Body Dia. DIM "C" | CL to UMB DIM "D" | Liner Dia. on Face DIM "J" | Lift Ring Height DIM "K" | Sensor Weight lbs. (kg) |
|------------------------------------|----------------|--------------|-------------------|-------------------|----------------------------|--------------------------|-------------------------|
| | Dim "A" PTFE | | | | | | |
| "3 (80) ANSI - 150# SO / RF" | 7.87 (200) | 7.87 (200) | 7.21 (183) | 5.82 (148) | 5.00 (127) | 1.70 (43) | 42 (19.1) |
| "3 (80) ANSI - 300# SO / RF" | 8.63 (219) | 8.63 (219) | 7.21 (183) | 5.82 (148) | 5.00 (127) | 1.70 (43) | 47 (21.3) |
| "3 (80) DIN - PN40 SO / RF" | 7.87 (200) | 7.87 (200) | 7.21 (183) | 5.82 (148) | 5.43 (138) | 1.70 (43) | 26 (11.8) |
| "3 (80) AUST. TABLE "D" SO / RF" | 7.87 (200) | 7.87 (200) | 7.21 (183) | 5.82 (148) | 5.00 (127) | 1.70 (43) | 42 (19.1) |
| "3 (80) AUST. TABLE "E" SO / RF" | 7.87 (200) | 7.87 (200) | 7.21 (183) | 5.82 (148) | 5.00 (127) | 1.70 (43) | 47 (21.3) |
| "3 (80) JIS - 10K SO / RF" | 7.87 (200) | 7.87 (200) | 7.21 (183) | 5.82 (148) | 4.96 (126) | 1.70 (43) | 29 (13.2) |
| "3 (80) JIS - 20K SO / RF" | 7.87 (200) | 7.87 (200) | 7.21 (183) | 5.82 (148) | 5.20 (132) | 1.70 (43) | 35 (16.0) |
| "4 (100) ANSI - 150# SO / RF" | 9.84 (250) | 9.84 (250) | 7.91 (201) | 6.17 (157) | 6.19 (157) | 1.70 (43) | 57 (25.9) |
| "4 (100) ANSI - 300# SO / RF" | 10.88 (276) | 10.87 (276) | 7.91 (201) | 6.17 (157) | 6.19 (157) | 1.70 (43) | 65 (29.5) |
| "4 (100) DIN - PN16 SO / RF" | 9.84 (250) | 9.84 (250) | 7.91 (201) | 6.17 (157) | 6.22 (158) | 1.70 (43) | 48 (21.8) |
| "4 (100) DIN - PN40 SO / RF" | 9.84 (250) | 9.84 (250) | 7.91 (201) | 6.17 (157) | 6.38 (162) | 1.70 (43) | 65 (29.5) |
| "4 (100) AUST. TABLE "D" SO / RF" | 9.84 (250) | 9.84 (250) | 7.91 (201) | 6.17 (157) | 6.19 (157) | 1.70 (43) | 57 (25.9) |
| "4 (100) AUST. TABLE "E" SO / RF" | 9.84 (250) | 9.84 (250) | 7.91 (201) | 6.17 (157) | 6.19 (157) | 1.70 (43) | 65 (29.5) |
| "4 (100) JIS - 10K SO / RF" | 9.84 (250) | 9.84 (250) | 7.91 (201) | 6.17 (157) | 5.95 (151) | 1.70 (43) | 36 (16.4) |
| "4 (100) JIS - 20K SO / RF" | 9.84 (250) | 9.84 (250) | 7.91 (201) | 6.17 (157) | 6.30 (160) | 1.70 (43) | 45 (20.6) |
| "6 (150) ANSI - 150# SO / RF" | 11.81 (300) | 11.81 (300) | 9.98 (253) | 7.30 (185) | 8.50 (216) | 1.70 (43) | 71 (32.2) |
| "6 (150) ANSI - 300# SO / RF" | 13.06 (332) | 13.06 (332) | 9.98 (253) | 7.30 (185) | 8.50 (216) | 1.70 (43) | 93 (42.2) |
| "6 (150) DIN - PN16 SO / RF" | 11.81 (300) | 11.81 (300) | 9.98 (253) | 7.30 (185) | 8.35 (212) | 1.70 (43) | 81 (36.7) |
| "6 (150) DIN - PN25 SO / RF" | 11.81 (300) | 11.81 (300) | 9.98 (253) | 7.30 (185) | 8.58 (218) | 1.70 (43) | 87 (39.6) |
| "6 (150) DIN - PN40 SO / RF" | 13.06 (332) | 13.06 (332) | 9.98 (253) | 7.30 (185) | 8.58 (218) | 1.70 (43) | 93 (42.2) |
| "6 (150) AUST. TABLE "D" SO / RF" | 11.81 (300) | 11.81 (300) | 9.98 (253) | 7.30 (185) | 8.50 (216) | 1.70 (43) | 71 (32.2) |
| "6 (150) AUST. TABLE "E" SO / RF" | 11.81 (300) | 11.81 (300) | 9.98 (253) | 7.30 (185) | 8.50 (216) | 1.70 (43) | 93 (42.2) |
| "6 (150) JIS - 10K SO / RF" | 11.81 (300) | 11.81 (300) | 9.98 (253) | 7.30 (185) | 8.35 (212) | 1.70 (43) | 66 (30.0) |
| "6 (150) JIS - 20K SO / RF" | 11.81 (300) | 11.81 (300) | 9.98 (253) | 7.30 (185) | 9.06 (230) | 1.70 (43) | 85 (38.7) |
| "8 (200) ANSI - 150# SO / RF" | 13.78 (350) | 13.78 (350) | 11.92 (303) | 8.27 (210) | 10.62 (270) | 1.70 (43) | 145 (65.8) |
| "8 (200) ANSI - 300# SO / RF" | 15.60 (396) | 15.60 (396) | 11.92 (303) | 8.27 (210) | 10.62 (270) | 1.70 (43) | 162 (73.5) |
| "8 (200) DIN - PN10 SO / RF" | 13.78 (350) | 13.78 (350) | 11.92 (303) | 8.27 (210) | 10.55 (268) | 1.70 (43) | 110 (49.9) |
| "8 (200) DIN - PN16 SO / RF" | 13.78 (350) | 13.78 (350) | 11.92 (303) | 8.27 (210) | 10.55 (268) | 1.70 (43) | 110 (49.9) |
| "8 (200) DIN - PN25 SO / RF" | 13.78 (350) | 13.78 (350) | 11.92 (303) | 8.27 (210) | 10.94 (278) | 1.70 (43) | 162 (73.5) |
| "8 (200) DIN - PN40 SO / RF" | 15.60 (396) | 15.60 (396) | 11.92 (303) | 8.27 (210) | 11.22 (285) | 1.70 (43) | 162 (73.5) |
| "8 (200) AUST. TABLE "D" SO / RF" | 13.78 (350) | 13.78 (350) | 11.92 (303) | 8.27 (210) | 10.62 (270) | 1.70 (43) | 145 (65.8) |
| "8 (200) AUST. TABLE "E" SO / RF" | 13.78 (350) | 13.78 (350) | 11.92 (303) | 8.27 (210) | 10.62 (270) | 1.70 (43) | 162 (73.5) |
| "8 (200) JIS - 10K SO / RF" | 13.78 (350) | 13.78 (350) | 11.92 (303) | 8.27 (210) | 10.32 (262) | 1.70 (43) | 82 (37.3) |
| "8 (200) JIS - 20K SO / RF" | 15.60 (396) | 15.60 (396) | 11.92 (303) | 8.27 (210) | 10.83 (275) | 1.70 (43) | 137 (62.3) |
| "10 (250) ANSI - 150# SO / RF" | 15.00 (381) | 14.76 (376) | 14.64 (372) | 9.69 (246) | 12.75 (324) | 2.00 (51) | 195 (88.5) |
| "10 (250) ANSI - 300# SO / RF" | 17.13 (435) | 16.89 (430) | 14.64 (372) | 9.69 (246) | 12.75 (324) | 2.00 (51) | 300 (99.8) |
| "10 (250) DIN - PN10 SO / RF" | 15.00 (381) | 14.76 (376) | 14.64 (372) | 9.69 (246) | 12.60 (320) | 2.00 (51) | 220 (99.8) |
| "10 (250) DIN - PN16 SO / RF" | 15.00 (381) | 14.76 (376) | 14.64 (372) | 9.69 (246) | 12.60 (320) | 2.00 (51) | 220 (99.8) |
| "10 (250) DIN - PN25 SO / RF" | 15.00 (381) | 14.76 (376) | 14.64 (372) | 9.69 (246) | 13.19 (335) | 2.00 (51) | 220 (99.8) |
| "10 (250) DIN - PN40 SO / RF" | 17.13 (435) | 16.89 (430) | 14.64 (372) | 9.69 (246) | 13.58 (345) | 2.00 (51) | 300 (99.8) |
| "10 (250) AUST. TABLE "D" SO / RF" | 15.00 (381) | 14.76 (376) | 14.64 (372) | 9.69 (246) | 12.75 (324) | 2.00 (51) | 195 (88.5) |
| "10 (250) AUST. TABLE "E" SO / RF" | 15.00 (381) | 14.76 (376) | 14.64 (372) | 9.69 (246) | 12.75 (324) | 2.00 (51) | 300 (99.8) |
| "12 (300) ANSI - 150# SO / RF" | 18.00 (457) | 17.76 (452) | 16.80 (427) | 10.77 (274) | 15.00 (381) | 2.00 (51) | 330 (149.7) |
| "12 (300) ANSI - 300# SO / RF" | 20.14 (512) | 19.89 (506) | 16.80 (427) | 10.77 (274) | 15.00 (381) | 2.00 (51) | 435 (197.3) |
| "12 (300) DIN - PN10 SO / RF" | 18.00 (457) | 17.76 (452) | 16.80 (427) | 10.77 (274) | 14.57 (370) | 2.00 (51) | 330 (149.7) |
| "12 (300) DIN - PN16 SO / RF" | 18.00 (457) | 17.76 (452) | 16.80 (427) | 10.77 (274) | 14.88 (378) | 2.00 (51) | 330 (149.7) |
| "12 (300) DIN - PN25 SO / RF" | 18.00 (457) | 17.76 (452) | 16.80 (427) | 10.77 (274) | 15.55 (395) | 2.00 (51) | 330 (149.7) |
| "12 (300) DIN - PN40 SO / RF" | 20.14 (512) | 19.89 (506) | 16.80 (427) | 10.77 (274) | 16.14 (410) | 2.00 (51) | 435 (197.3) |
| "12 (300) AUST. TABLE "D" SO / RF" | 18.00 (457) | 17.76 (452) | 16.80 (427) | 10.77 (274) | 15.00 (381) | 2.00 (51) | 330 (149.7) |
| "12 (300) AUST. TABLE "E" SO / RF" | 18.00 (457) | 17.76 (452) | 16.80 (427) | 10.77 (274) | 15.00 (381) | 2.00 (51) | 435 (197.3) |

Table B-3. 14-in. through 36-in. with Slip-On Flanges (mm)

| Size, Description | Overall Length | Dim. "A" Poly | Body Dim. "C" | CL to UMB Dim. "D" | Liner on Face Dim. "J" | Lift Ring Height Dim. "K" | Sensor Weight (lbs.) |
|------------------------------------|----------------|---------------|---------------|--------------------|------------------------|---------------------------|----------------------|
| | Dim. "A" PTFE | | | | | | |
| "14 (350) ANSI - 150# SO / RF" | 20.91 (531) | 20.83 (529) | 18.92 (481) | 11.83 (300) | 16.25 (413) | 2.00 (51) | 380 (172.4) |
| "14 (350) ANSI - 300# SO / RF" | 23.16 (588) | 23.08 (586) | 18.92 (481) | 11.83 (300) | 16.25 (413) | 2.00 (51) | 573 (259.9) |
| "14 (350) DIN - PN10 SO / RF" | 20.91 (531) | 20.83 (529) | 18.92 (481) | 11.83 (300) | 16.93 (430) | 2.00 (51) | 370 (167.8) |
| "14 (350) DIN - PN16 SO / RF" | 20.91 (531) | 20.83 (529) | 18.92 (481) | 11.83 (300) | 17.24 (438) | 2.00 (51) | 370 (167.8) |
| "14 (350) DIN - PN25 SO / RF" | 23.16 (588) | 23.08 (586) | 18.92 (481) | 11.83 (300) | 17.72 (450) | 2.00 (51) | 370 (167.8) |
| "14 (350) DIN - PN40 SO / RF" | 23.16 (588) | 23.08 (586) | 18.92 (481) | 11.83 (300) | 18.31 (465) | 2.00 (51) | 573 (259.9) |
| "14 (350) AUST. TABLE "D" SO / RF" | 20.91 (531) | 20.83 (529) | 18.92 (481) | 11.83 (300) | 16.25 (413) | 2.00 (51) | 380 (172.4) |
| "14 (350) AUST. TABLE "E" SO / RF" | 20.91 (531) | 20.83 (529) | 18.92 (481) | 11.83 (300) | 16.25 (413) | 2.00 (51) | 573 (259.9) |
| "16 (400) ANSI - 150# SO / RF" | 23.88 (607) | 23.80 (607) | 20.94 (532) | 12.84 (326) | 18.50 (470) | 3.13 (80) | 470 (213.2) |
| "16 (400) ANSI - 300# SO / RF" | 26.13 (664) | 26.05 (664) | 20.94 (532) | 12.84 (326) | 18.50 (470) | 3.13 (80) | 755 (213.2) |
| "16 (400) DIN - PN10 SO / RF" | 23.88 (607) | 23.80 (607) | 20.94 (532) | 12.84 (326) | 18.98 (482) | 3.13 (80) | 500 (213.2) |
| "16 (400) DIN - PN16 SO / RF" | 23.88 (607) | 23.80 (607) | 20.94 (532) | 12.84 (326) | 19.29 (490) | 3.13 (80) | 500 (213.2) |
| "16 (400) DIN - PN25 SO / RF" | 26.13 (664) | 26.05 (664) | 20.94 (532) | 12.84 (326) | 19.88 (505) | 3.13 (80) | 500 (213.2) |
| "16 (400) DIN - PN40 SO / RF" | 26.13 (664) | 26.05 (664) | 20.94 (532) | 12.84 (326) | 21.06 (535) | 3.13 (80) | 755 (213.2) |
| "16 (400) AUST. TABLE "D" SO / RF" | 23.88 (607) | 23.80 (607) | 20.94 (532) | 12.84 (326) | 18.50 (470) | 3.13 (80) | 470 (213.2) |
| "16 (400) AUST. TABLE "E" SO / RF" | 23.88 (607) | 23.80 (607) | 20.94 (532) | 12.84 (326) | 18.50 (470) | 3.13 (80) | 755 (213.2) |
| "18 (450) ANSI - 150# SO / RF" | 26.85 (682) | 26.77 (680) | 23.46 (596) | 14.10 (358) | 21.00 (533) | 3.13 (80) | 592 (268.5) |
| "18 (450) ANSI - 300# SO / RF" | 29.97 (761) | 29.89 (759) | 23.46 (596) | 14.10 (358) | 21.00 (533) | 3.13 (80) | 1010 (458.1) |
| "18 (450) DIN - PN10 SO / RF" | 26.85 (682) | 26.72 (679) | 23.46 (596) | 14.10 (358) | 20.94 (532) | 3.13 (80) | 522 (236.8) |
| "18 (450) DIN - PN16 SO / RF" | 26.85 (682) | 26.72 (679) | 23.46 (596) | 14.10 (358) | 21.65 (550) | 3.13 (80) | 595 (269.9) |
| "18 (450) DIN - PN25 SO / RF" | 29.97 (761) | 29.89 (759) | 23.46 (596) | 14.10 (358) | 21.85 (555) | 3.13 (80) | 693 (314.3) |
| "18 (450) DIN - PN40 SO / RF" | 29.97 (761) | 29.89 (759) | 23.46 (596) | 14.10 (358) | 22.05 (560) | 3.13 (80) | 915 (415.0) |
| "18 (450) AUST. TABLE "D" SO / RF" | 26.85 (682) | 26.77 (680) | 23.46 (596) | 14.10 (358) | 21.00 (533) | 3.13 (80) | 592 (268.5) |
| "18 (450) AUST. TABLE "E" SO / RF" | 26.85 (682) | 26.77 (680) | 23.46 (596) | 14.10 (358) | 21.00 (533) | 3.13 (80) | 1010 (458.1) |
| "20 (500) ANSI - 150# SO / RF" | 29.78 (756) | 29.70 (754) | 25.48 (647) | 15.11 (384) | 23.00 (584) | 3.13 (80) | 680 (308.4) |
| "20 (500) ANSI - 300# SO / RF" | 33.04 (839) | 32.96 (837) | 25.48 (647) | 15.11 (384) | 23.00 (584) | 3.13 (80) | 1180 (535.2) |
| "20 (500) DIN - PN10 SO / RF" | 29.78 (756) | 29.70 (754) | 25.48 (647) | 15.11 (384) | 23.03 (585) | 3.13 (80) | 680 (535.2) |
| "20 (500) DIN - PN16 SO / RF" | 29.78 (756) | 29.70 (754) | 25.48 (647) | 15.11 (384) | 24.02 (610) | 3.13 (80) | 680 (535.2) |
| "20 (500) DIN - PN25 SO / RF" | 33.04 (839) | 32.96 (837) | 25.48 (647) | 15.11 (384) | 24.21 (615) | 3.13 (80) | 680 (535.2) |
| "20 (500) DIN - PN40 SO / RF" | 33.04 (839) | 32.96 (837) | 25.48 (647) | 15.11 (384) | 24.21 (615) | 3.13 (80) | 1180 (535.2) |
| "20 (500) AUST. TABLE "D" SO / RF" | 29.78 (756) | 29.70 (754) | 25.48 (647) | 15.11 (384) | 23.00 (584) | 3.13 (80) | 680 (535.2) |
| "20 (500) AUST. TABLE "E" SO / RF" | 29.78 (756) | 29.70 (754) | 25.48 (647) | 15.11 (384) | 23.00 (584) | 3.13 (80) | 1180 (535.2) |
| "24 (600) ANSI - 150# SO / RF" | 35.75 (908) | 35.67 (906) | 30.03 (763) | 17.39 (442) | 27.25 (692) | 3.13 (80) | 1020 (462.7) |
| "24 (600) ANSI - 300# SO / RF" | 39.38 (1000) | 39.30 (998) | 30.03 (763) | 17.39 (442) | 27.25 (692) | 3.13 (80) | 1865 (845.9) |
| "24 (600) DIN - PN10 SO / RF" | 35.75 (908) | 35.67 (906) | 30.03 (763) | 17.39 (442) | 26.97 (685) | 3.13 (80) | 1000 (453.6) |
| "24 (600) DIN - PN16 SO / RF" | 35.75 (908) | 35.67 (906) | 30.03 (763) | 17.39 (442) | 28.54 (725) | 3.13 (80) | 1000 (453.6) |
| "24 (600) DIN - PN25 SO / RF" | 39.38 (1000) | 39.30 (998) | 30.03 (763) | 17.39 (442) | 28.35 (720) | 3.13 (80) | 1000 (453.6) |
| "24 (600) DIN - PN40 SO / RF" | 39.38 (1000) | 39.30 (998) | 30.03 (763) | 17.39 (442) | 28.94 (735) | 3.13 (80) | 1615 (734.2) |
| "24 (600) AUST. TABLE "D" SO / RF" | 35.75 (908) | 35.67 (906) | 30.03 (763) | 17.39 (442) | 27.25 (692) | 3.13 (80) | 1020 (462.7) |
| "24 (600) AUST. TABLE "E" SO / RF" | 35.75 (908) | 35.67 (906) | 30.03 (763) | 17.39 (442) | 27.25 (692) | 3.13 (80) | 1865 (845.9) |
| "30 (750) AWWA CLASS D SO / RF" | 37.00 (940) | 36.93 (938) | 35.50 (902) | 20.13 (511) | 33.75 (857) | 3.13 (80) | 1400 (635.0) |
| "30 (750) MSS SP44 - 150# SO / RF" | 41.56 (1056) | 41.48 (1054) | 35.50 (902) | 20.13 (511) | 33.75 (857) | 3.13 (80) | 1782 (808.3) |
| "30 (750) MSS SP44 - 300# SO / RF" | 47.25 (1200) | 47.17 (1198) | 35.50 (902) | 20.13 (511) | 33.75 (857) | 3.13 (80) | 2610 (1183.9) |
| "30 (750) AUST. TABLE "D" SO / RF" | 37.00 (940) | 36.93 (938) | 35.50 (902) | 20.13 (511) | 34.96 (888) | 3.13 (80) | 1530 (694.0) |
| "30 (750) AUST. TABLE "E" SO / RF" | 41.56 (1056) | 41.48 (1054) | 35.50 (902) | 20.13 (511) | 34.84 (885) | 3.13 (80) | 1663 (754.3) |
| "36 (900) AWWA CLASS D SO / RF" | 40.63 (1032) | 40.55 (1030) | 43.37 (1102) | 24.00 (1022) | 40.25 (1022) | 3.13 (80) | 1975 (895.8) |
| "36 (900) MSS SP44 - 150# SO / RF" | 47.25 (1200) | 47.17 (1198) | 43.37 (1102) | 24.00 (1022) | 40.25 (1022) | 3.13 (80) | 2777 (1259.6) |
| "36 (900) AUST. TABLE "D" SO / RF" | 40.63 (1032) | 40.55 (1030) | 43.37 (1102) | 24.00 (1022) | 41.34 (1050) | 3.13 (80) | 2213 (1003.8) |
| "36 (900) AUST. TABLE "E" SO / RF" | 47.25 (1200) | 47.17 (1198) | 43.37 (1102) | 24.00 (1022) | 41.34 (1050) | 3.13 (80) | 2437 (1105.4) |

Figure B-6. ATEX Installation (3 of 6)

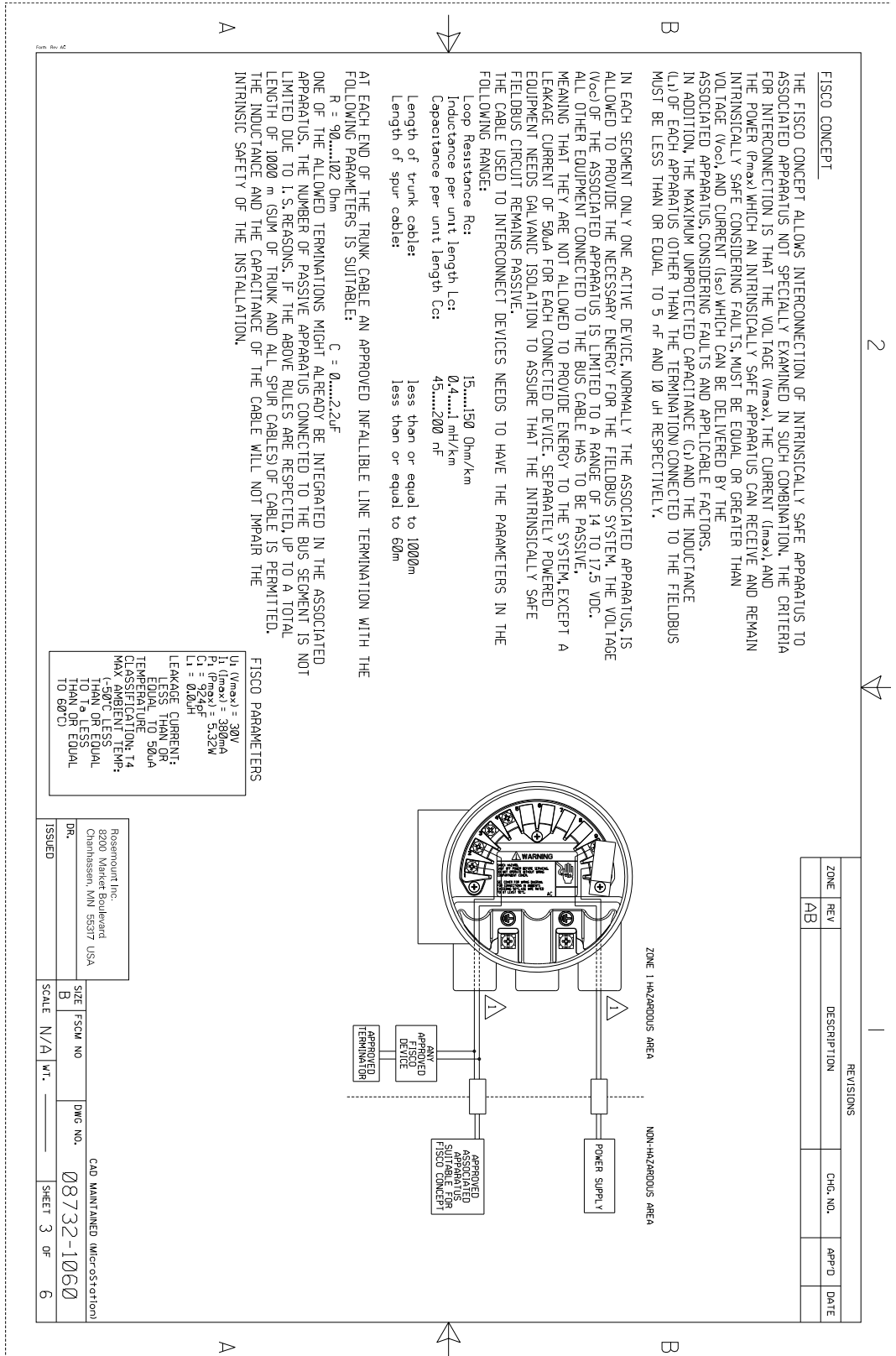

Rosemount 8732

Figure B-7. ATEX Installation (4 of 6)

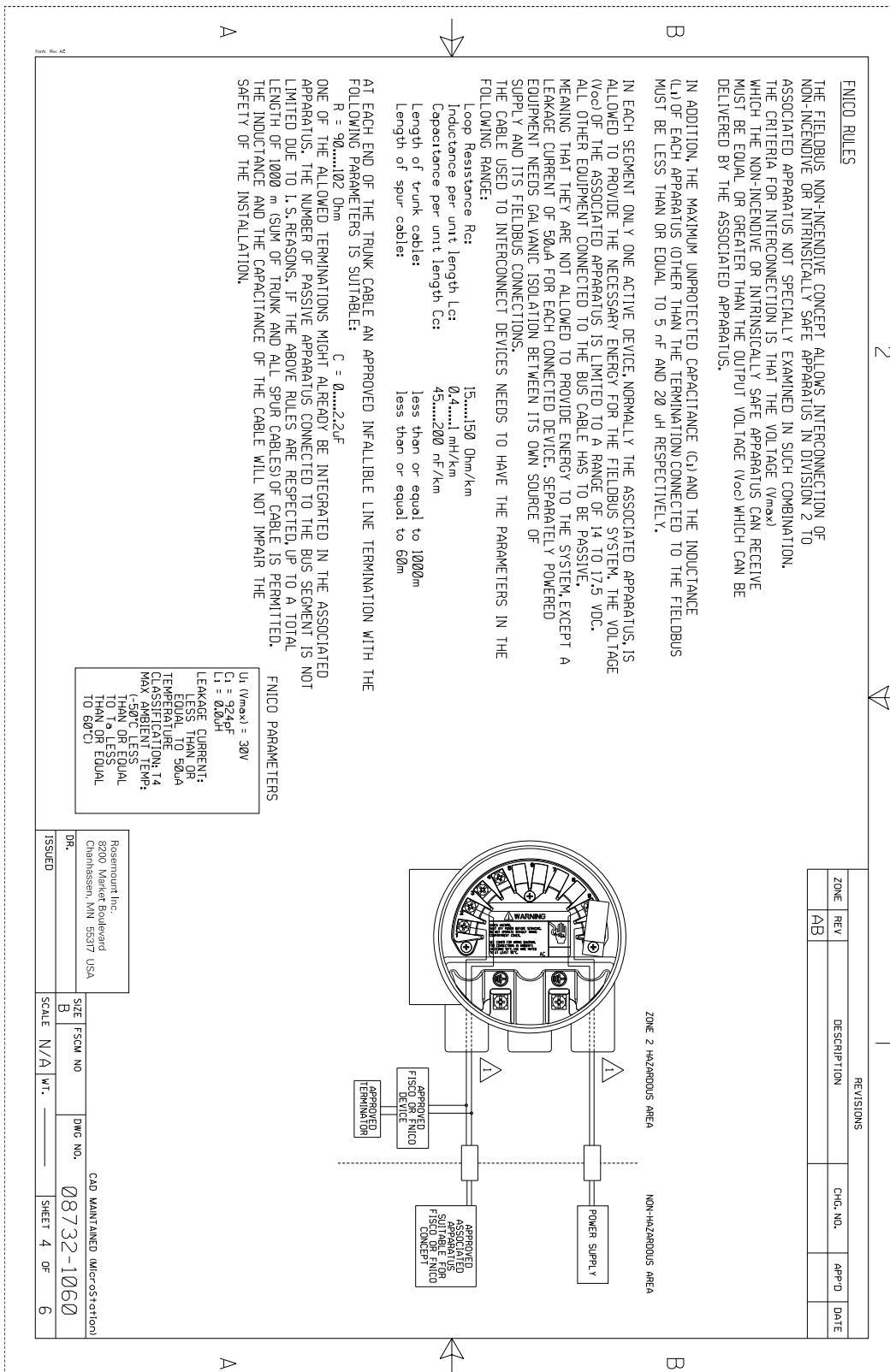
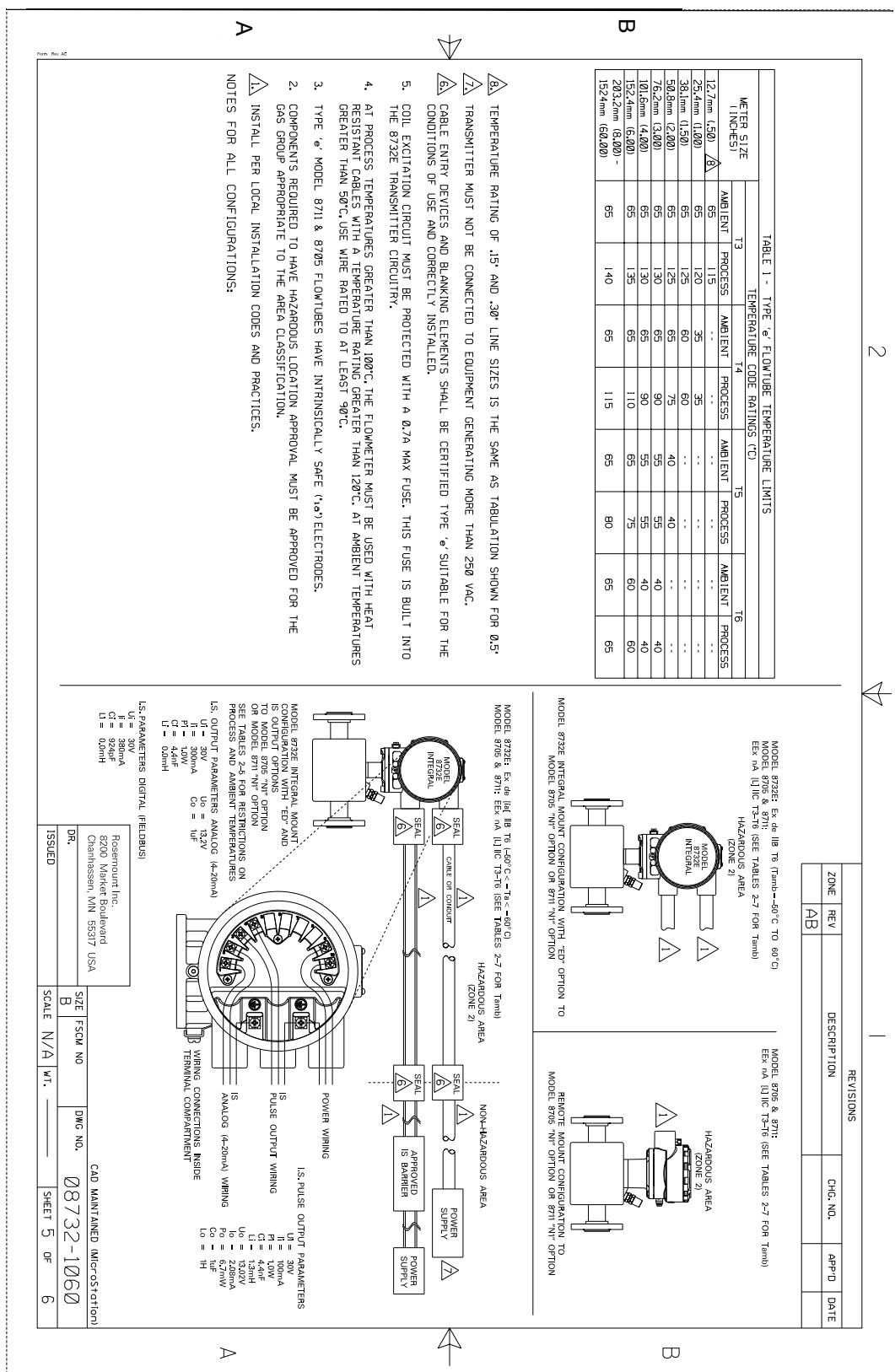

Figure B-8. ATEX Installation (5 of 6)



Rosemount 8732

Figure B-9. ATEX Installation (6 of 6)

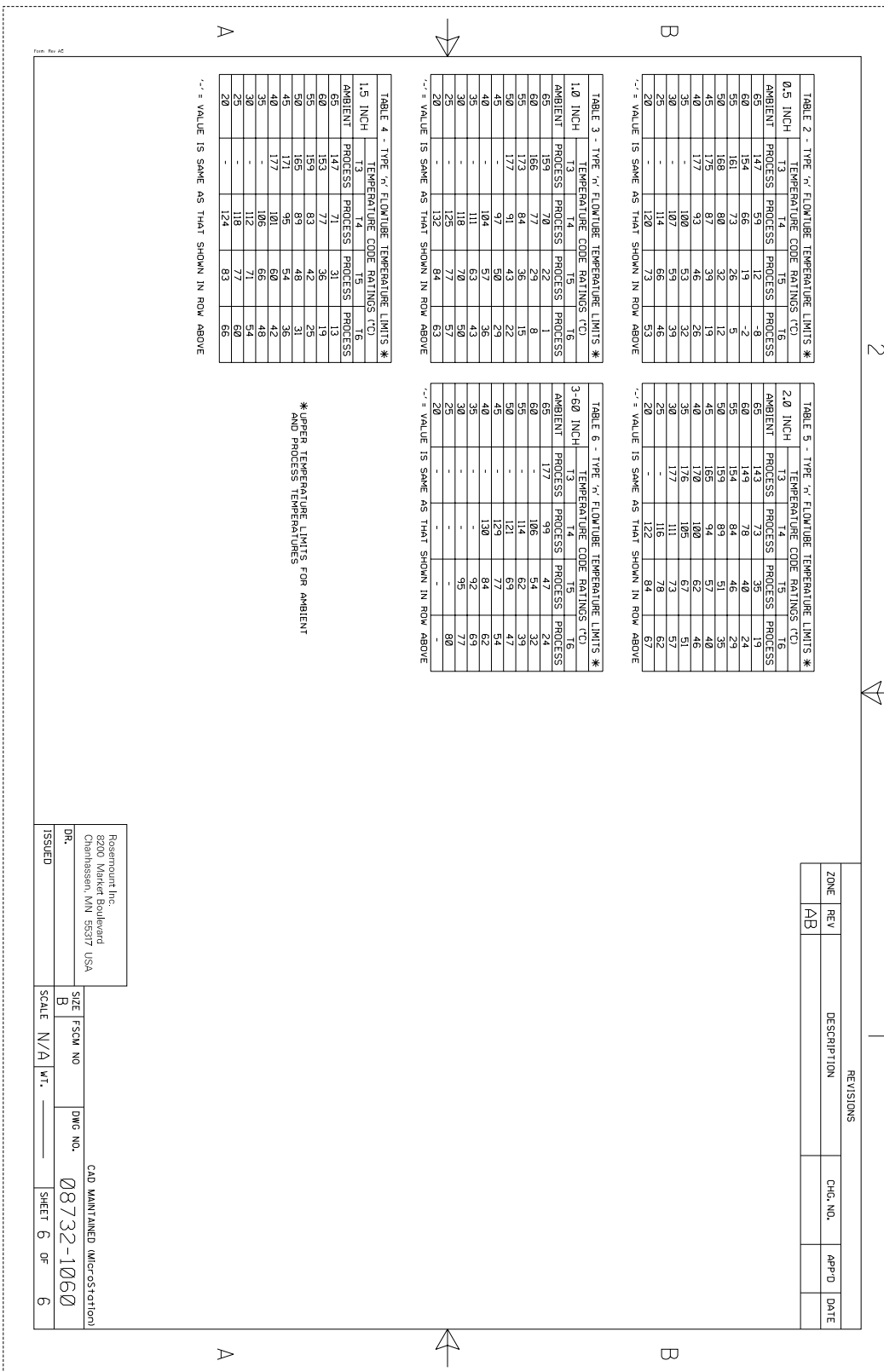
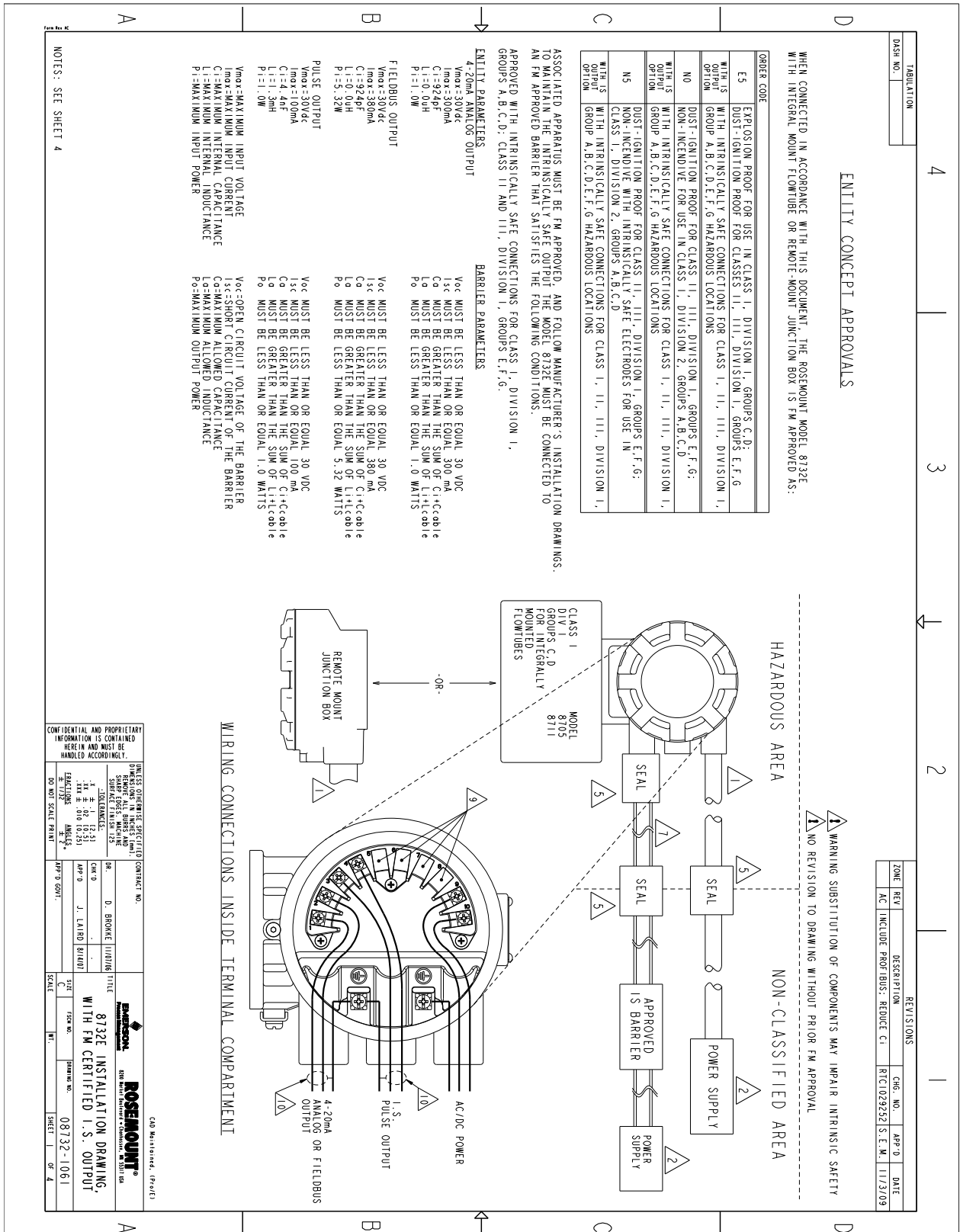

Figure B-10. FM Certified I.S. Output (1 of 4)



Rosemount 8732

Figure B-11. FM Certified I.S. Output (2 of 4)

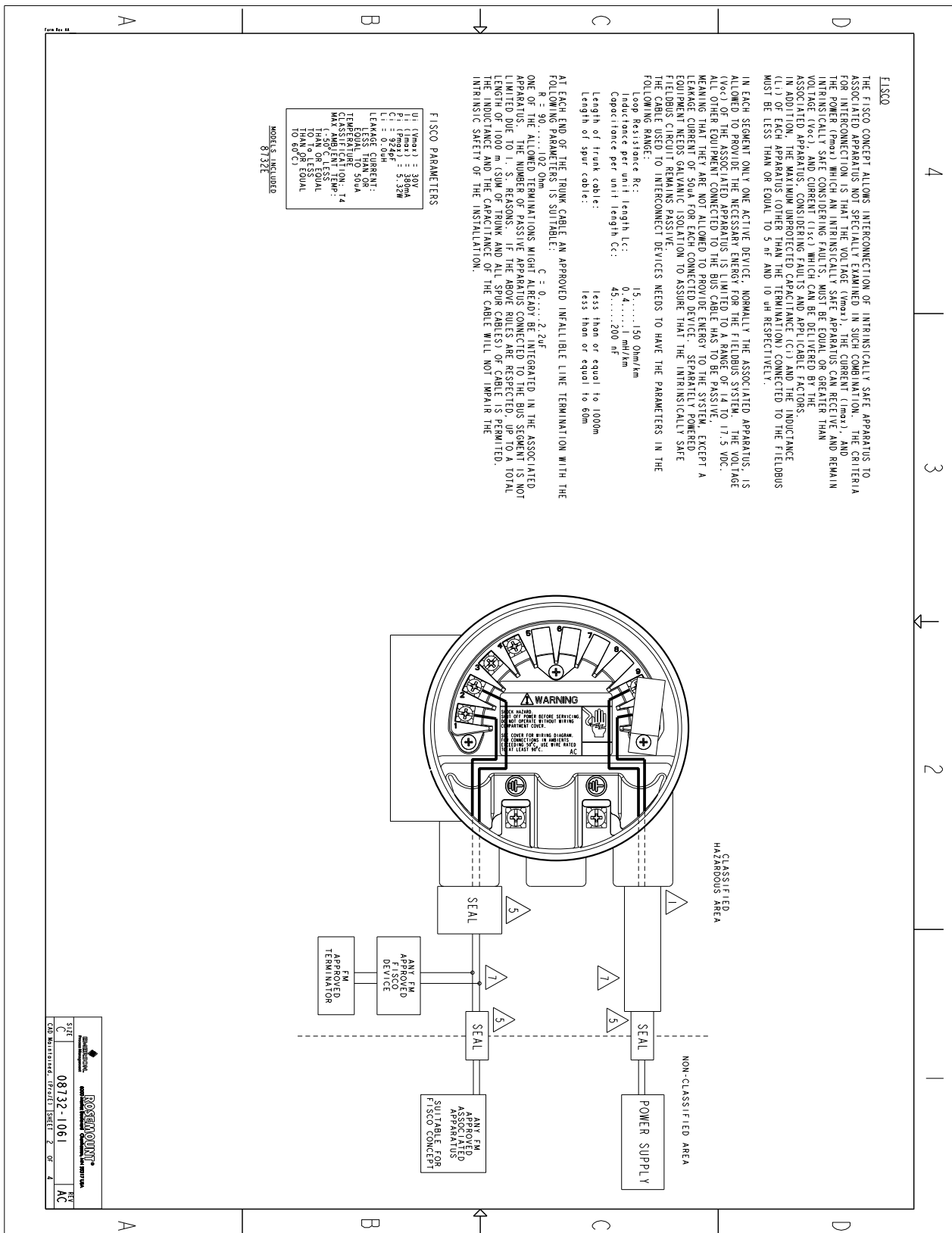

Figure B-13. FM Certified I.S. Output (4 of 4)

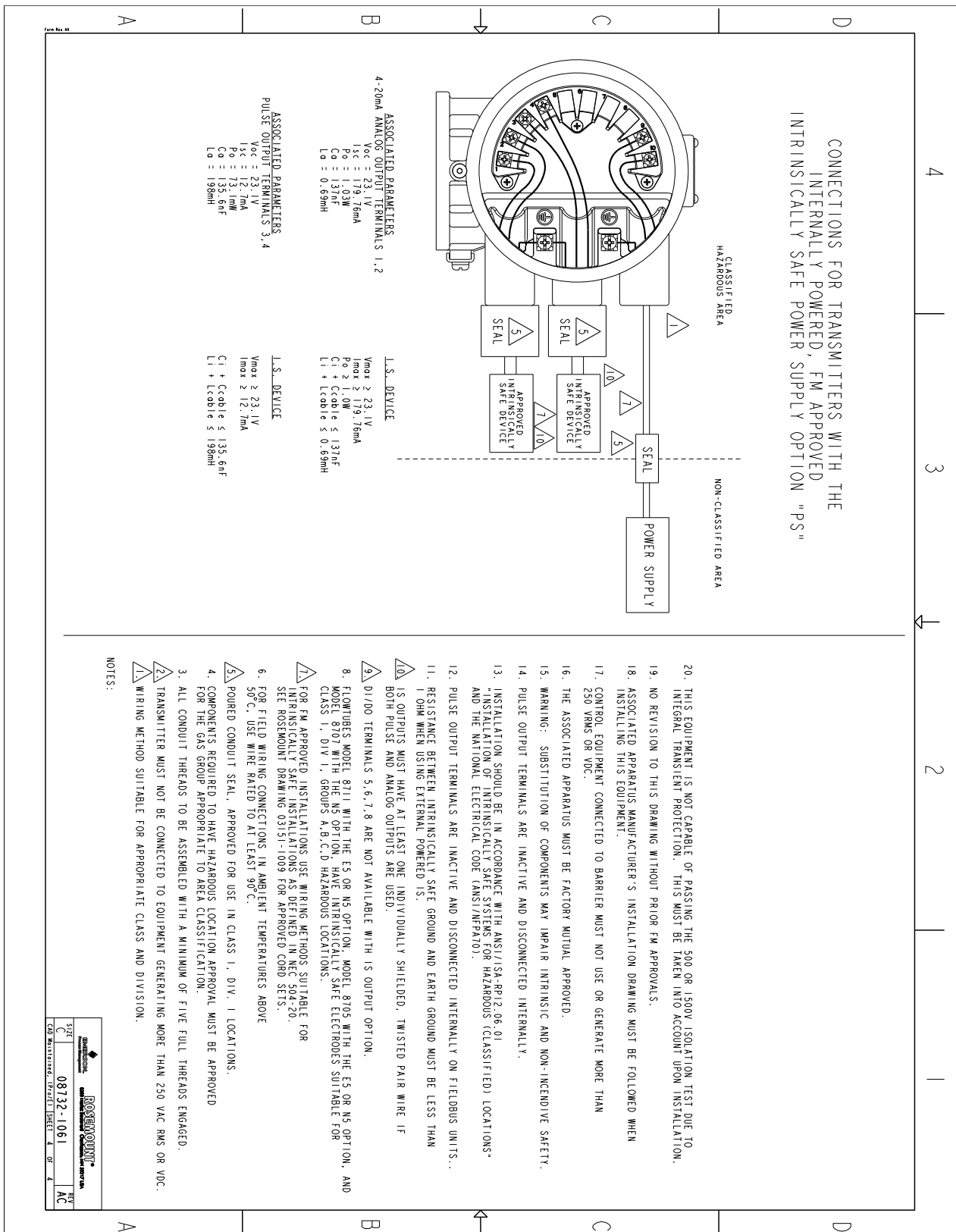

Figure B-14. CSA Certified I.S. Output (1 of 4)

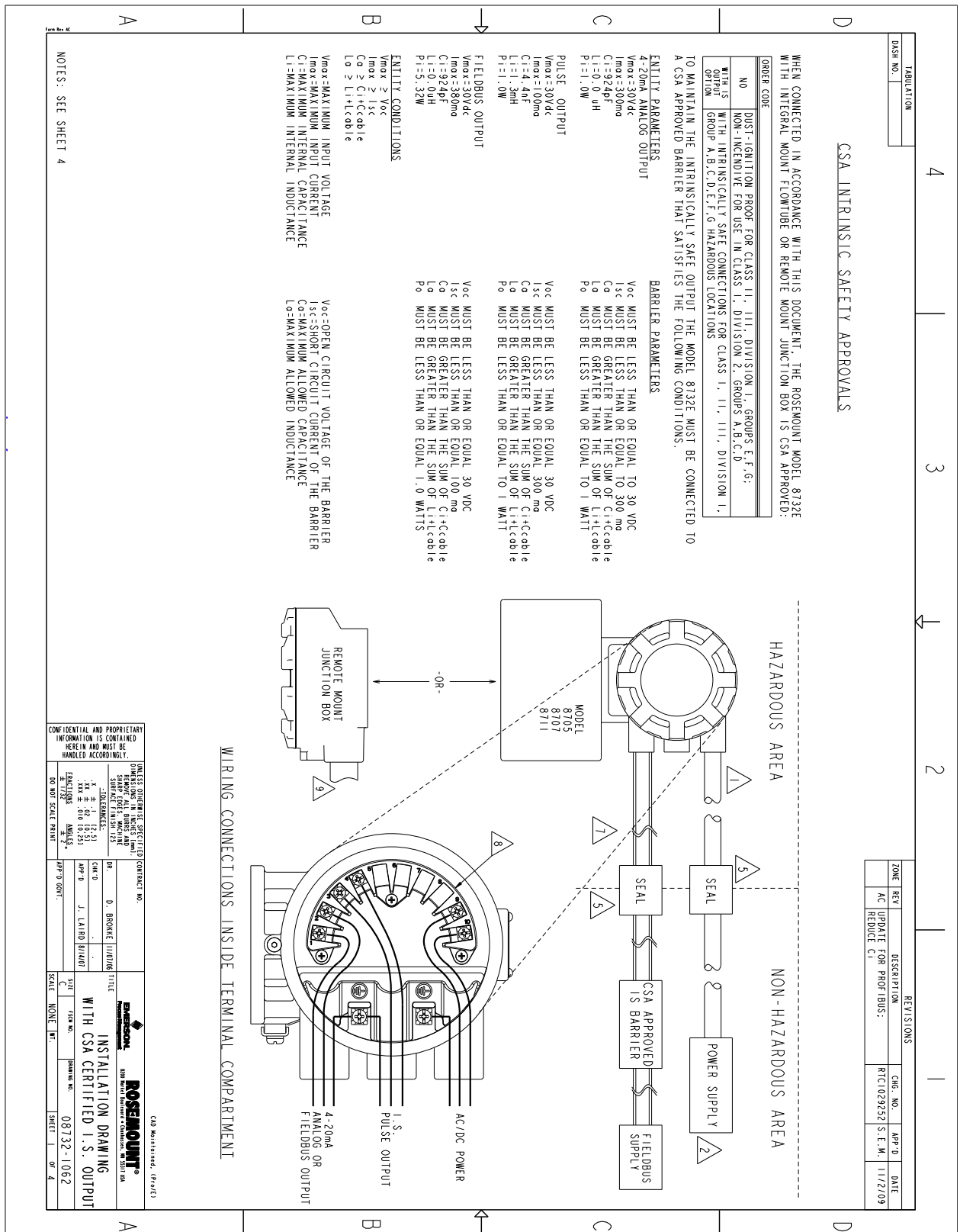

Figure B-15. CSA Certified I.S. Output (2 of 4)

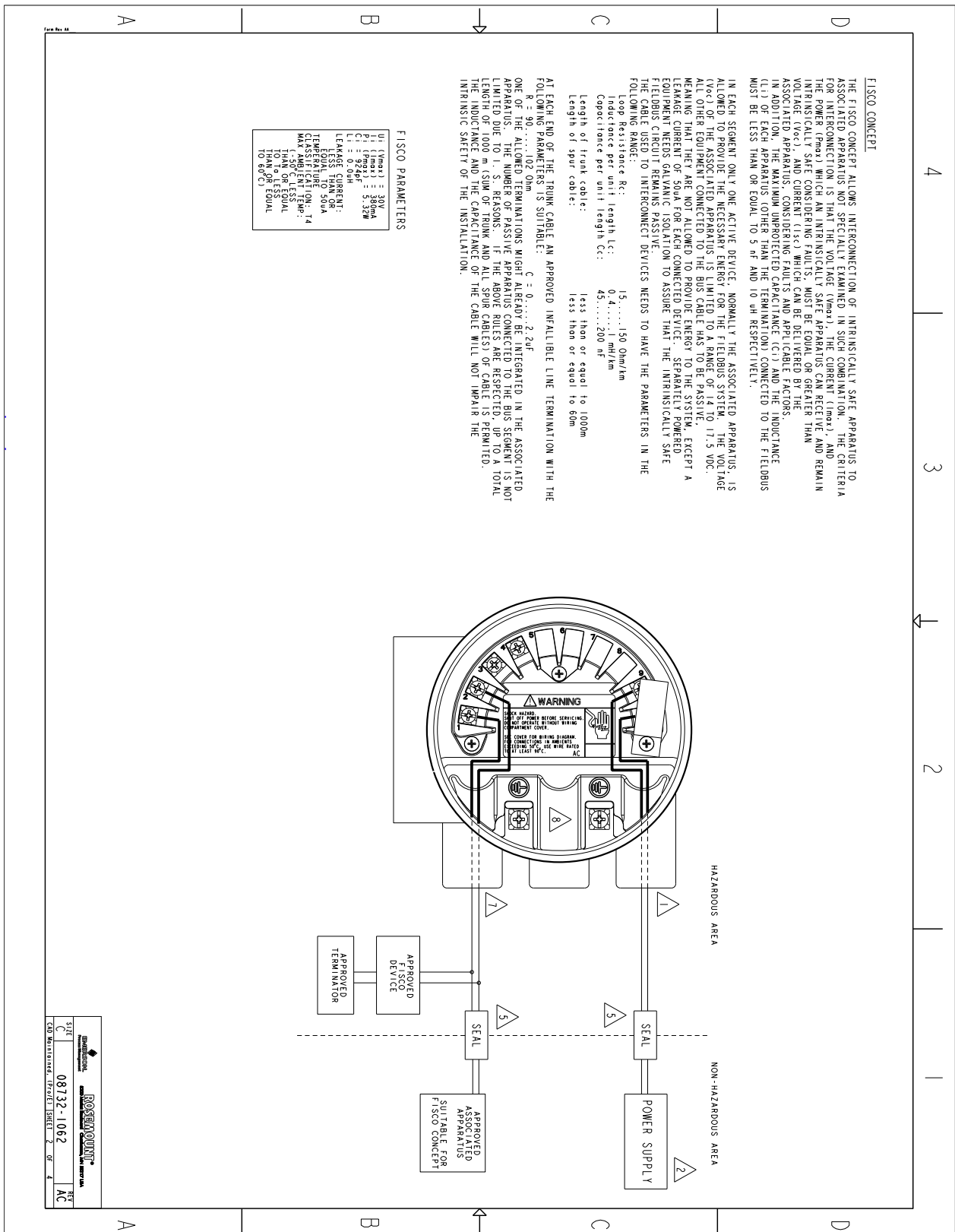

Figure B-16. CSA Certified I.S. Output (3 of 4)

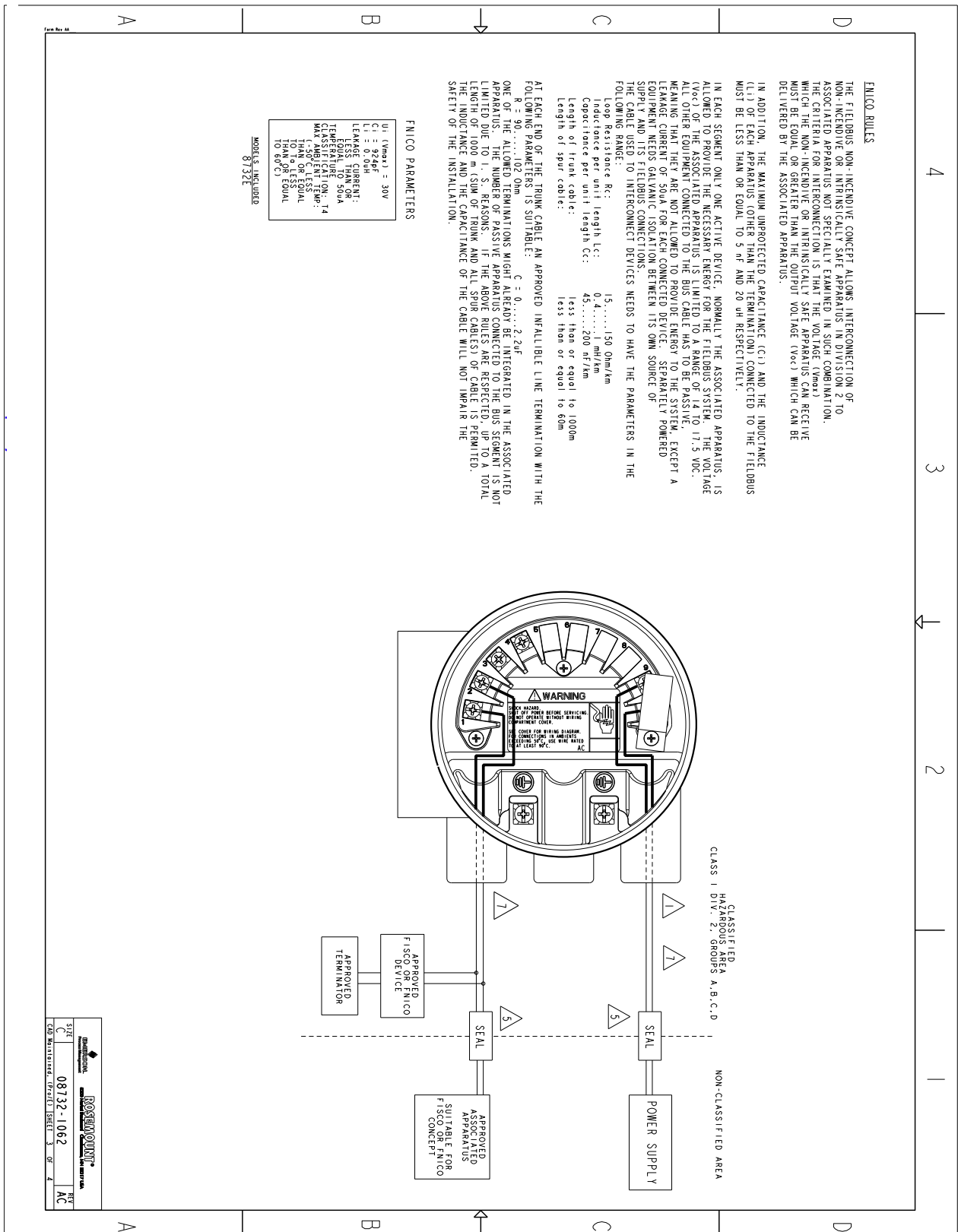

Figure B-17. CSA Certified I.S. Output (4 of 4)

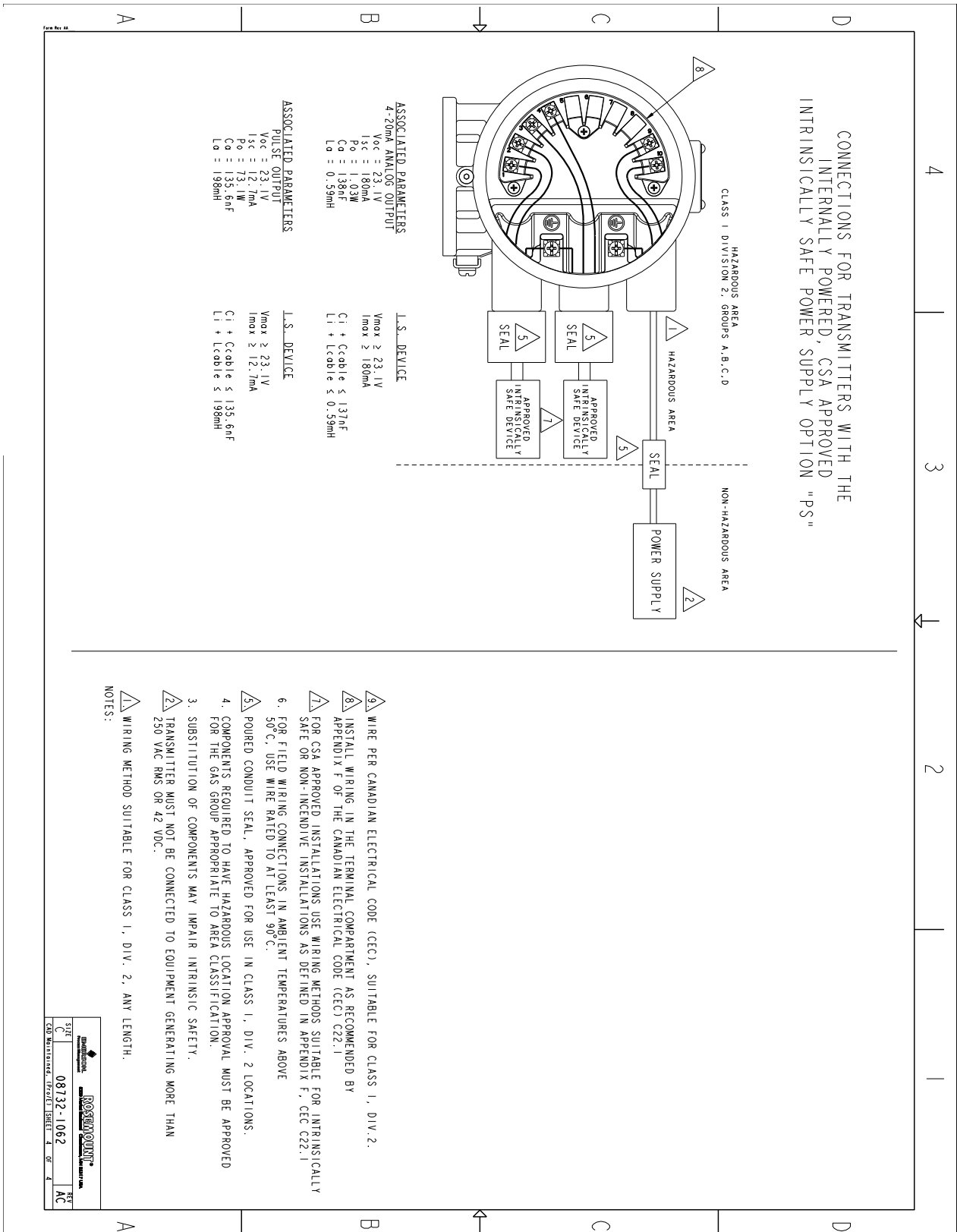

Figure B-18. CSA Installation

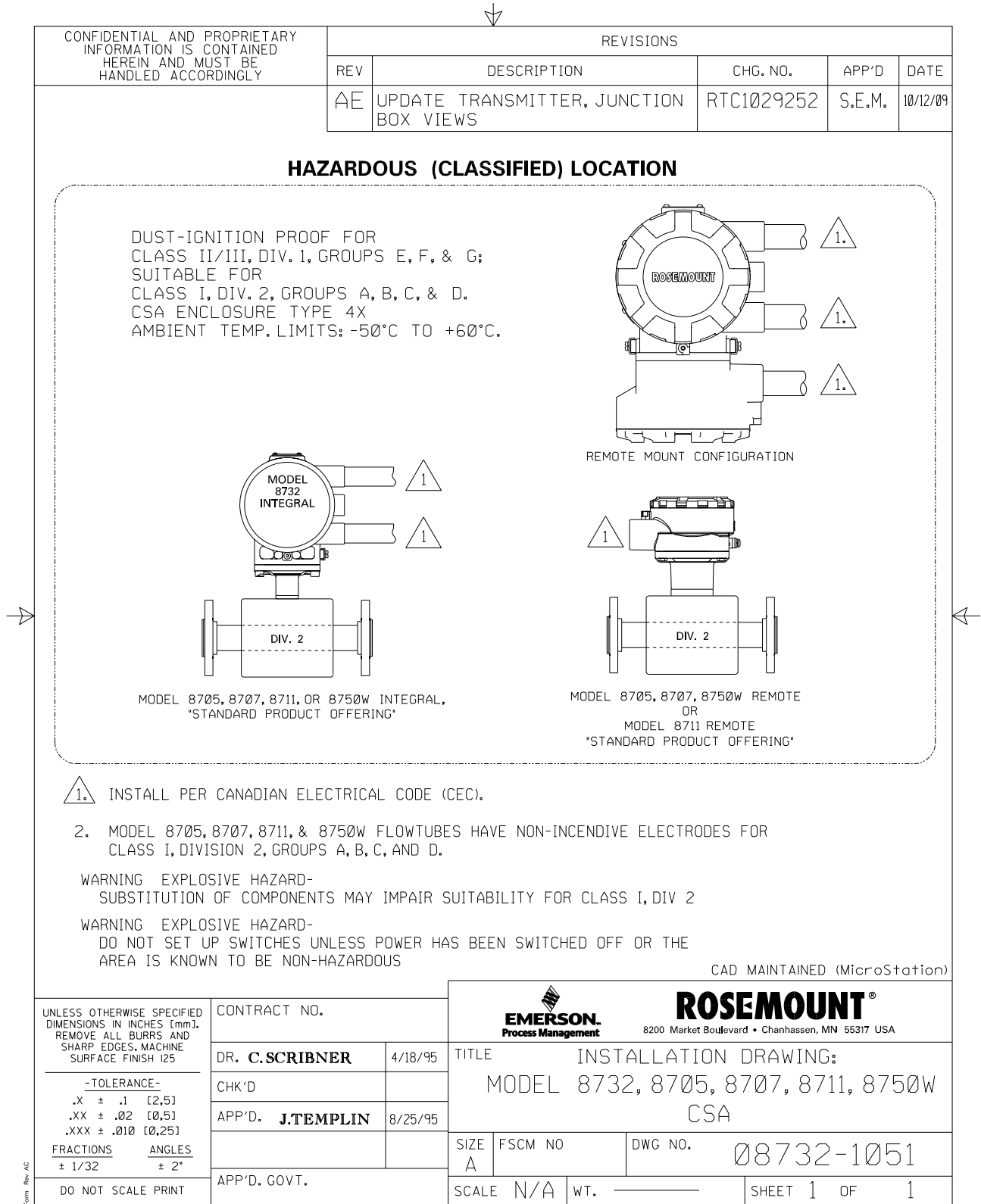
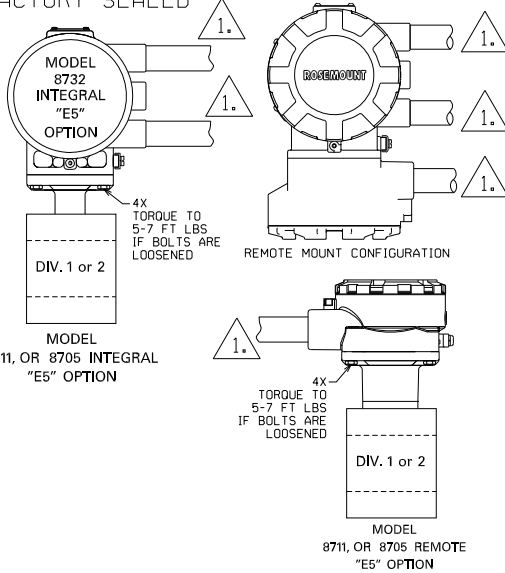

Figure B-19. Factory Mutual Hazardous Locations

| CONFIDENTIAL AND PROPRIETARY INFORMATION IS CONTAINED HEREIN AND MUST BE HANDLED ACCORDINGLY | REVISIONS | | | |
|--|-----------|---------------------|------------|----------------|
| | REV | DESCRIPTION | CHG. NO. | APP'D DATE |
| | AF | UPDATE JUNCTION BOX | RTC1028826 | S.E.M. 7/23/09 |

HAZARDOUS (CLASSIFIED) LOCATION

EXPLOSION PROOF FOR CLASS I, DIV. 1, GROUPS C, D; T6
DUST-IGNITION PROOF FOR CLASS II/III, DIV. 1, GROUPS E, F, G; T6
NONINCENDIVE FOR CLASS I, DIV. 2, GROUPS A, B, C, D; T4
ENCLOSURE TYPE 4X
AMBIENT TEMP. LIMITS: -50°C TO +60°C.
FACTORY SEALED



DUST-IGNITION PROOF FOR CLASS II/III, DIV. 1, GROUPS E, F, G; T6
NONINCENDIVE FOR CLASS I, DIV. 2, GROUPS A, B, C, D; T4
ENCLOSURE TYPE 4X
AMBIENT TEMP. LIMITS: -50°C TO +60°C.

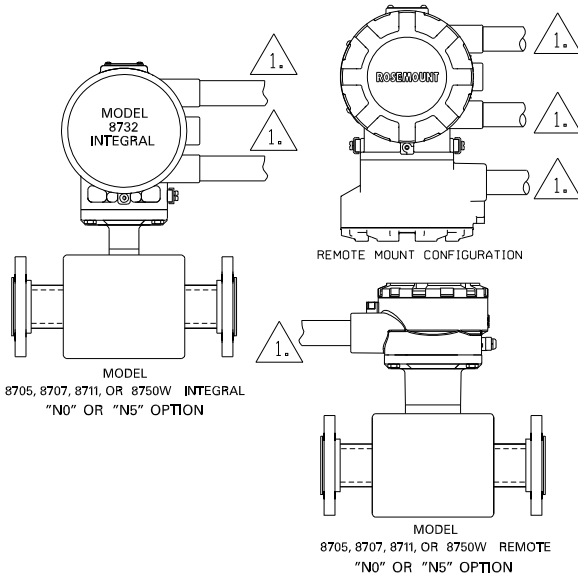

3. MODEL 8711 AND 8705 WITH E5 AND N5 OPTION, AND 8750W AND 8707 WITH N5 OPTION FLOWTUBES HAVE INTRINSICALLY SAFE ELECTRODES SUITABLE FOR FLAMMABLE PROCESS.

2. ALL CONDUIT THREADS MUST BE ASSEMBLED WITH A MINIMUM OF FIVE FULL THREADS ENGAGEMENT.

1. INSTALL PER NATIONAL ELECTRICAL CODE (NEC) FOR DIVISION 1 OR 2 INSTALLATIONS.

NOTES:

CAD MAINTAINED (MicroStation)

UNLESS OTHERWISE SPECIFIED DIMENSIONS IN INCHES [mm]. REMOVE ALL BURRS AND SHARP EDGES. MACHINE SURFACE FINISH 125

-TOLERANCE-
.X ± .1 [2,5]
.XX ± .02 [0,5]
.XXX ± .010 [0,25]

FRACTIONS ANGLES
± 1/32 ± 2°

DO NOT SCALE PRINT

| | |
|------------------|---------|
| CONTRACT NO. | |
| DR. C.SCRIBNER | 4/18/95 |
| CHK'D | |
| APP'D. J.TEMPLIN | 8/25/95 |
| APP'D. GOVT. | |

| | | | |
|--|---------|--------------------|--|
| | | | |
| 8200 Market Boulevard • Chanhassen, MN 55317 USA | | | |
| TITLE INSTALLATION DRAWING: MODEL 8705, 8707, 8711, 8732, 8750W FACTORY MUTUAL HAZARDOUS LOCATIONS | | | |
| SIZE A | FSCM NO | DWG NO. 08732-1052 | |
| SCALE N/A | WT. | SHEET 1 OF 1 | |

Appendix C Diagnostics

| | |
|---|-----------|
| Diagnostic Availability | page C-1 |
| Licensing and Enabling | page C-2 |
| Tunable Empty Pipe Detection | page C-3 |
| Ground/Wiring Fault Detection | page C-4 |
| High Process Noise Detection | page C-6 |
| Coated Electrode Detection | page C-8 |
| Smart Meter Verification (8714i) | page C-10 |
| Rosemount Magnetic Flowmeter Calibration Verification Report | page C-22 |

DIAGNOSTIC AVAILABILITY

Rosemount Magmeters provide device diagnostics that powers PlantWeb and informs the user of abnormal situations throughout the life of the meter - from installation to maintenance and meter verification. With Rosemount Magmeter diagnostics enabled, users can change their practices to improve plant availability and output, and reduce costs through simplified installation, maintenance and troubleshooting.

| Diagnostics | Mag User Practice | 8732 HART |
|-----------------------------------|--------------------------|------------|
| Basic | | |
| Empty Pipe | Process Management | • |
| Electronics Temperature | Maintenance | • |
| Coil Fault | Maintenance | • |
| Transmitter Faults | Maintenance | • |
| Reverse Flow | Process Management | • |
| Advanced (Suite 1) | | DA1 Option |
| High Process Noise | Process Management | • |
| Grounding/Wiring Fault | Installation | • |
| Coated Electrode Detection | Maintenance | • |
| Advanced (Suite 2) | | DA2 Option |
| Smart Meter Verification™ (8714i) | Calibration Verification | • |
| 4-20 mA Loop Verification | Maintenance | • |

Options for Accessing Diagnostics

Rosemount Magmeter Diagnostics can be accessed through the Local Operator Interface (LOI), a Field Communicator, and AMS Device Manager.

Access Diagnostics through the LOI for quicker installation, maintenance, and meter verification

Rosemount Magmeter Diagnostics are available through the LOI to make maintenance of every magmeter easier.

Access Diagnostics through AMS Device Manager for the Ultimate Value

The value of the Diagnostics increases significantly when AMS is used. Now the user gets a simplified screen flow and procedures for how to respond to the Diagnostic messages.

LICENSING AND ENABLING

All advanced diagnostics are licensed by ordering option code DA1, DA2, or both. In the event that a diagnostic option is not ordered, advanced diagnostics can be licensed in the field through the use of a license key. Each transmitter has a unique license key specific to the diagnostic option code. A trial license is also available to enable the advanced diagnostics. This temporary functionality will be automatically disabled after 30-days or when power to the transmitter is cycled which ever occurs first. This trial code can be used a maximum of three times per transmitter. See the detailed procedures below for entering the license key and enabling the advanced diagnostics. To obtain a permanent or trial license key, contact your local Rosemount Representative.

Licensing the 8732 Diagnostics

For licensing the advanced diagnostics, follow the steps below.

1. Power-up the 8732 transmitter
2. Verify that you have 5.2.1 software or later

| | |
|-----------|---|
| Fast Keys | 1, 4, 6, 10, -- ⁽¹⁾ |
| LOI Menu | Detailed Setup, Device Info, Revision Num, Software Rev |
| AMS Tab | License |

3. Determine the Device ID

| | |
|-----------|--|
| Fast Keys | 1, 4, 6, 6 |
| LOI Menu | Detailed Setup, Device Info, Device ID |
| AMS Tab | License |

4. Obtain a License Key from your local Rosemount Representative.

5. Enter License Key

| | |
|-----------|--|
| Fast Keys | 1, 2, 3, 4, 2, 2 |
| LOI Menu | Diagnostics, Advanced Diag, Licensing, License Key |
| AMS Tab | License |

6. Enable Advanced Diagnostics

| | |
|-----------|----------------------------|
| Fast Keys | 1, 2, 1 |
| LOI Menu | Diagnostics, Diag Controls |
| AMS Tab | Diagnostics |

(1) This item is in a list format without numeric labels.

**TUNABLE EMPTY PIPE
 DETECTION**

The Tunable Empty Pipe detection provides a means of minimizing issues and false readings when the pipe is empty. This is most important in batching applications where the pipe may run empty with some regularity.

If the pipe is empty, this diagnostic will activate, set the flow rate to 0, and deliver a PlantWeb alert.

Turning Empty Pipe On/Off

| | |
|-----------|--|
| Fast Keys | 1, 2, 1, 1 |
| LOI Menu | Diagnostics, Diag Controls, Empty Pipe |
| AMS Tab | Diagnostics |

The Empty Pipe diagnostic can be turned on or off as required by the application. If the advanced diagnostics suite 1 (DA1 Option) was ordered, then the Empty Pipe diagnostic will be turned on. If DA1 was not ordered, the default setting is off.

**Tunable Empty Pipe
 Parameters**

The Tunable Empty Pipe diagnostic has one read-only parameter, and two parameters that can be custom configured to optimize the diagnostic performance.

Empty Pipe (EP) Value

| | |
|-----------|------------------------------------|
| Fast Keys | 1, 2, 2, 4, 1 |
| LOI Menu | Diagnostics, Variables, Empty Pipe |
| AMS Tab | Diagnostics |

Reads the current Empty Pipe Value. This is a read-only value. This number is a unitless number and is calculated based on multiple installation and process variables such as sensor type, line size, process fluid properties, and wiring. If the Empty Pipe Value exceeds the Empty Pipe Trigger Level for a specified number of updates, then the Empty Pipe diagnostic alert will activate.

Empty Pipe (EP) Trigger Level

| | |
|-----------|-------------------------------------|
| Fast Keys | 1, 2, 2, 4, 2 |
| LOI Menu | Diagnostics, Basic Diag, Empty Pipe |
| AMS Tab | Diagnostics |

Limits: 3 to 2000

This value configures the threshold limit that the Empty Pipe Value must exceed before the Empty Pipe diagnostic alert activates. The default setting from the factory is 100.

Empty Pipe (EP) Counts

| | |
|-----------|-------------------------------------|
| Fast Keys | 1, 2, 2, 4, 3 |
| LOI Menu | Diagnostics, Basic Diag, Empty Pipe |
| AMS Tab | Diagnostics |

Limits: 5 to 50

This value configures the number of consecutive updates that the Empty Pipe Value must exceed the Empty Pipe Trigger Level before the Empty Pipe diagnostic alert activates. The default setting from the factory is 5.

Rosemount 8732

Optimizing Tunable Empty Pipe

The Tunable Empty Pipe diagnostic is set at the factory to properly diagnose most applications. If this diagnostic unexpectedly activates, the following procedure can be followed to optimize the Empty Pipe diagnostic for the application.

Example

1. Record the Empty Pipe Value with a full pipe condition.

Full reading = 0.2

2. Record the Empty Pipe Value with an empty pipe condition.

Empty reading = 80.0

3. Set the Empty Pipe Trigger Level to a value between the full and empty readings. For increased sensitivity to empty pipe conditions, set the trigger level to a value closer to the full pipe value.

Set the trigger level to 25.0

4. Set the Empty Pipe Counts to a value corresponding to the desired sensitivity level for the diagnostic. For applications with entrained air or potential air slugs, less sensitivity may be desired.

Set the counts to 10

Troubleshooting Empty Pipe

The following actions can be taken if Empty Pipe detection is unexpected.

1. Verify the sensor is full.
2. Verify that the sensor has not been installed with a measurement electrode at the top of the pipe.
3. Decrease the sensitivity by setting the Empty Pipe Trigger Level to a value above the Empty Pipe Value read with a full pipe.
4. Decrease the sensitivity by increasing the Empty Pipe Counts to compensate for process noise. The Empty Pipe Counts is the number of consecutive Empty Pipe Value readings above the Empty Pipe Trigger Level required to set the Empty Pipe diagnostic. The count range is 5-50, with factory default set at 5.
5. Increase process fluid conductivity above 50 microsiemens/cm.
6. Properly connect the wiring between the sensor and the transmitter. Corresponding terminal block numbers in the sensor and transmitter must be connected.
7. Perform the sensor electrical resistance tests. Confirm the resistance reading between coil ground (ground symbol) and coil (1 and 2) is infinity, or open. Confirm the resistance reading between electrode ground (17) and an electrode (18 or 19) is greater than 2 kohms and rises. For more detailed information, consult Table 6-4 on page 6-6.

GROUND/WIRING FAULT DETECTION

The Ground/Wiring Fault Detection diagnostic provides a means of verifying installations are done correctly. If the installation is not wired or grounded properly, this diagnostic will activate and deliver a PlantWeb alert. This diagnostic can also detect if the grounding is lost over-time due to corrosion or another root cause.

(1) This item is in a list format without numeric labels.

Turning Ground/Wiring Fault On/Off

| | |
|-----------|---|
| Fast Keys | 1, 2, 1, 1, -- ⁽¹⁾ |
| LOI Menu | Diagnostics, Diag Controls, Ground/Wiring |
| AMS Tab | Diagnostics |

The Ground/Wiring Fault diagnostic can be turned on or off as required by the application. If the advanced diagnostics suite 1 (DA1 Option) was ordered, then the Ground/Wiring Fault diagnostic will be turned on. If DA1 was not ordered or licensed, this diagnostic is not available.

Ground/Wiring Fault Parameters

The Ground/Wiring Fault diagnostic has one read-only parameter. It does not have any configurable parameters.

Line Noise

| | |
|-----------|------------------------------------|
| Fast Keys | 1, 2, 4, 3 |
| LOI Menu | Diagnostics, Variables, Line Noise |
| AMS Tab | Diagnostics |

Reads the current amplitude of the Line Noise. This is a read-only value. This number is a measure of the signal strength at 50/60 Hz. If the Line Noise value exceeds 5 mV, then the Ground/Wiring Fault diagnostic alert will activate.

Troubleshooting Ground/Wiring Fault

The transmitter detected high levels of 50/60 Hz noise caused by improper wiring or poor process grounding.

1. Verify that the transmitter is earth grounded.
2. Connect ground rings, grounding electrode, lining protector, or grounding straps. Grounding diagrams can be found in "Grounding" on page 5-12.
3. Verify sensor is full.
4. Verify wiring between sensor and transmitter is prepared properly. Shielding should be stripped back less than 1 in. (25 mm).
5. Use separate shielded twisted pairs for wiring between sensor and transmitter.
6. Properly connect the wiring between the sensor and the transmitter. Corresponding terminal block numbers in the sensor and transmitter must be connected.

Ground/Wiring Fault Functionality

The transmitter continuously monitors signal amplitudes over a wide range of frequencies. For the Ground/Wiring Fault diagnostic, the transmitter specifically looks at the signal amplitude at frequencies of 50 Hz and 60 Hz which are the common AC cycle frequencies found throughout the world. If the amplitude of the signal at either of these frequencies exceeds 5 mV, that is an indication that there is a ground or wiring issue and that stray electrical signals are getting into the transmitter. The diagnostic alert will activate indicating that the ground and wiring of the installation should be carefully reviewed.

Rosemount 8732

HIGH PROCESS NOISE DETECTION

The High Process Noise diagnostic detects if there is a process condition causing unstable or noisy readings, but the noise is not real flow variation. One common cause of high process noise is slurry flow, like pulp stock or mining slurries. Other conditions that cause this diagnostic to activate are high levels of chemical reaction or entrained gas in the liquid. If unusual noise or variation is seen, this diagnostic will activate and deliver a PlantWeb alert. If this situation exists and is left without remedy, it will add additional uncertainty and noise to the flow reading.

Turning High Process Noise On/Off

| | |
|-----------|---|
| Fast Keys | 1, 2, 1, 1, -- ⁽¹⁾ |
| LOI Menu | Diagnostics, Diag Controls, Process Noise |
| AMS Tab | Diagnostics |

The High Process Noise diagnostic can be turned on or off as required by the application. If the advanced diagnostics suite 1 (DA1 Option) was ordered, then the High Process Noise diagnostic will be turned on. If DA1 was not ordered or licensed, this diagnostic is not available.

High Process Noise Parameters

The High Process Noise diagnostic has two read-only parameters. It does not have any configurable parameters. This diagnostic requires that flow be present in the pipe and the velocity be > 1 ft/s.

5 Hz Signal to Noise Ratio (SNR)

| | |
|-----------|---------------------------------|
| Fast Keys | 1, 2, 4, 4 |
| LOI Menu | Diagnostics, Variables, 5Hz SNR |
| AMS Tab | Diagnostics |

Reads the current value of the signal to noise ratio at the coil drive frequency of 5 Hz. This is a read-only value. This number is a measure of the signal strength at 5 Hz relative to the amount of process noise. If the transmitter is operating in 5 Hz mode, and the signal to noise ratio remains below 25 for one minute, then the High Process Noise diagnostic alert will activate.

37 Hz Signal to Noise Ratio(SNR)

| | |
|-----------|----------------------------------|
| Fast Keys | 1, 2, 4, 5 |
| LOI Menu | Diagnostics, Variables, 37Hz SNR |
| AMS Tab | Diagnostics |

Reads the current value of the signal to noise ratio at the coil drive frequency of 37 Hz. This is a read-only value. This number is a measure of the signal strength at 37 Hz relative to the amount of process noise. If the transmitter is operating in 37 Hz mode, and the signal to noise ratio remains below 25 for one minute, then the High Process Noise diagnostic alert will activate.

Troubleshooting High Process Noise

The transmitter detected high levels of process noise. If the signal to noise ratio is less than 25 while operating in 5 Hz mode, proceed with the following steps:

1. Increase transmitter coil drive frequency to 37 Hz (refer to "Coils" on page 4-2) and, if possible, perform Auto Zero function (refer to "Auto Zero" on page 4-11).
2. Verify sensor is electrically connected to the process with grounding electrode, grounding rings with grounding straps, or lining protector with grounding straps.
3. If possible, redirect chemical additions downstream of the magmeter.
4. Verify process fluid conductivity is above 10 microsiemens/cm.⁽¹⁾

If the signal to noise ratio is less than 25 while operating in 37 Hz mode, proceed with the following steps:

1. Turn on the Digital Signal Processing (DSP) technology and follow the setup procedure (refer to Appendix D: Digital Signal Processing). This will minimize the level of damping in the flow measurement and control loop while also stabilizing the reading to minimize valve actuation.
2. Increase damping to stabilize the signal (refer to "PV Damping" on page 3-11). This will add dead-time to the control loop.
3. Move to a Rosemount High-Signal flowmeter system. This flowmeter will deliver a stable signal by increasing the amplitude of the flow signal by ten times to increase the signal to noise ratio. For example if the signal to noise ratio (SNR) of a standard magmeter is 5, the High-Signal would have a SNR of 50 in the same application. The Rosemount High-Signal system is comprised of the 8707 sensor which has modified coils and magnetics and the 8712H High-Signal transmitter.

NOTE

In applications where very high levels of noise are a concern, it is recommended that a dual-calibrated Rosemount High-Signal 8707 sensor be used. These sensors can be calibrated to run at lower coil drive current supplied by the standard Rosemount transmitters, but can also be upgraded by changing to the 8712H High-Signal transmitter.

High Process Noise Functionality

The High Process Noise diagnostic is useful for detecting situations where the process fluid may be causing electrical noise resulting in a poor measurement from the magnetic flowmeter. There are three basic types of process noise that can affect the performance of the magnetic flowmeter system.

1/f Noise

This type of noise has higher amplitudes at lower frequencies, but generally degrades over increasing frequencies. Potential sources of 1/f noise include chemical mixing and the general background noise of the plant.

Spike Noise

This type of noise generally results in a high amplitude signal at specific frequencies which can vary depending on the source of the noise. Common sources of spike noise include chemical injections directly upstream of the flowmeter, hydraulic pumps, and slurry flows with low concentrations of particles in the stream. The particles bounce off of the electrode generating a "spike" in the electrode signal. An example of this type of flow stream would be a recycle flow in a paper mill.

White Noise

This type of noise results in a high amplitude signal that is relatively constant over the frequency range. Common sources of white noise include chemical reactions or mixing that occurs as the fluid passes through the flowmeter and high concentration slurry flows where the particulates are constantly passing over the electrode head. An example of this type of flow stream would be a basis weight stream in a paper mill.

(1) This item is in a list format without numeric labels.

The transmitter continuously monitors signal amplitudes over a wide range of frequencies. For the high process noise diagnostic, the transmitter specifically looks at the signal amplitude at frequencies of 2.5 Hz, 7.5 Hz, 32.5 Hz, and 42.5 Hz. The transmitter uses the values from 2.5 and 7.5 Hz and calculates an average noise level. This average is compared to the amplitude of the signal at 5 Hz. If the signal amplitude is not 25 times greater than the noise level, and the coil drive frequency is set at 5 Hz, the High Process Noise diagnostic will trip indicating that the flow signal may be compromised. The transmitter performs the same analysis around the 37.5 Hz coil drive frequency using the 32.5 Hz and 42.5 Hz values to establish a noise level.

COATED ELECTRODE DETECTION

The Coated Electrode Detection diagnostic provides a means of monitoring coating buildup on the measurement electrodes. If coating is not detected, buildup over time can lead to a compromised flow measurement. This diagnostic can detect if the electrode is coated and if the amount of coating is affecting the flow measurement. There are two levels of electrode coating. Limit 1 indicates when coating is starting to occur, but has not compromised the flow measurement. Limit 2 indicates when coating is affecting the flow measurement and the meter should be serviced immediately.

Turning Coated Electrode Detection On/Off

| | |
|-----------|---|
| Fast Keys | 1, 2, 3, 1 |
| LOI Menu | Diagnostics, Diag Controls, Electrode Coating |
| AMS Tab | Diagnostics |

The Coated Electrode Detection diagnostic can be turned on or off as required by the application. If the advanced diagnostics suite 1 (DA1 Option) was ordered, then the Coated Electrode Detection diagnostic will be turned on. If DA1 was not ordered or licensed, this diagnostic is not available.

COATED ELECTRODE PARAMETERS

The Coated Electrode Detection diagnostic has four parameters. Two are read-only and two are configurable parameters. Each application needs to be monitored the first time to accurately adjust the configurable parameters.

Electrode Coating (EC) Value

| | |
|-----------|--|
| Fast Keys | 1, 2, 3, 1, 1 |
| LOI Menu | Diagnostics, Advanced Diag, Elec Coating |
| AMS Tab | Diagnostics |

The EC Current Val reads the current value of the Coated Electrode detection diagnostic.

Electrode Coating (EC) Level 1 Limit

| | |
|-----------|--|
| Fast Keys | 1, 2, 3, 1, 2 |
| LOI Menu | Diagnostics, Advanced Diag, Elec Coating |
| AMS Tab | Diagnostics |

Set the criteria for the EC Limit 1 which indicates when coating is starting to occur, but has not compromised the flow measurement. The default value for this parameter is 1000 kOhm.

Electrode Coating (EC) Level 2 Limit

| | |
|-----------|--|
| Fast Keys | 1, 2, 3, 1, 3 |
| LOI Menu | Diagnostics, Advanced Diag, Elec Coating |
| AMS Tab | Diagnostics |

Set the criteria for the EC Limit 2 which indicates when coating is affecting the flow measurement and the meter should be serviced immediately. The default value for this parameter is 3000 kOhm.

Max Electrode Coating (EC)

| | |
|-----------|--|
| Fast Keys | 1, 2, 3, 1, 4 |
| LOI Menu | Diagnostics, Advanced Diag, Elec Coating |
| AMS Tab | Diagnostics |

The EC Max Value reads the maximum value of the Coated Electrode detection diagnostic since the last Max Value reset.

Clear Max Electrode Value

| | |
|-----------|--|
| Fast Keys | 1, 2, 3, 1, 5 |
| LOI Menu | Diagnostics, Advanced Diag, Elec Coating |
| AMS Tab | Diagnostics |

This method allows you to reset the max electrode coating value.

**TROUBLESHOOTING
COATED ELECTRODE
DETECTION**

In the event that electrode coating is detected, the following steps can be used to determine the appropriate course of action.

| Error Message | Potential Causes of Failure | Steps to Correct |
|-----------------------------|---|--|
| "Electrode Coating Level 1" | <ul style="list-style-type: none"> Coating is starting to buildup on electrode and interfering with measurement signal Process fluid conductivity has changed | Schedule maintenance to clean electrode Use bullet nose electrodes Downsize sensor to increase flow rate above 3 ft/s (1ms) Verify process fluid conductivity |
| "Electrode Coating Level 2" | <ul style="list-style-type: none"> Coating has built-up on the electrodes and is interfering with measurement signal Process fluid conductivity has changed | Schedule maintenance to clean electrode Use bullet nose electrodes Downsize sensor to increase flow rate above 3 ft/s (1ms) |

**4-20 MA LOOP
VERIFICATION**

The 4-20 mA Loop Verification diagnostic provides a means of verifying the analog output loop is functioning properly. This is a manually initiated diagnostic test. This diagnostic checks the integrity of the analog loop and provides a health status of the circuit. If the verification does not pass, this will be highlighted in the results given at the end of the check.

Initiating 4-20 mA Loop Verification

| | |
|-----------|---|
| Fast Keys | 1, 2, 3, 3, 1 |
| LOI Menu | Diagnostics, Advanced Diag, 4-20 mA Verify, 4-20 mA Verify |
| AMS | Context Menu, Diagnostics and Tests, Analog Output Verification |

The 4-20 mA Loop Verification diagnostic can be initiated as required by the application. If the advanced diagnostics suite 2 (DA2 Option) was ordered, then the 4-20 mA Loop Verification diagnostic will be available. If DA2 was not ordered or licensed, this diagnostic is not available.

Rosemount 8732

4-20 mA Loop Verification Parameters

The 4-20 mA Loop Verification diagnostic has one read-only parameter. It does not have any configurable parameters.

4-20 mA Loop Verification Test Result

| | |
|-----------|--|
| Fast Keys | 1, 2, 3, 3, 2 |
| LOI Menu | Diagnostics, Advanced Diag, 4-20 mA Verify, View Results |
| AMS | |

Shows the results of the 4-20 mA Loop Verification test as either passed or failed.

Troubleshooting 4-20 mA Loop Verification

In the event that the 4-20 mA Loop Verification fails, the following steps can be used to determine the appropriate course of action.

| Test | Potential Causes of Failure | Steps to Correct |
|-----------------------------------|-----------------------------|---|
| 4-20 mA Loop Verification Failure | Analog loop not powered | Check analog loop wiring Check loop resistance Check 4-20 mA internal/external loop power switch-see "Internal/External Analog Power" on page 2-6 Check external supply voltage to the transmitter Check for parallel paths in the current loop |
| | Analog drift | Perform digital trim |
| | Transmitter failure | Perform transmitter self test Perform manual analog loop test Replace the electronics board |

4-20 mA Loop Verification Functionality

The 4-20 mA Loop Verification diagnostic is useful for testing the analog output when errors are suspected. The diagnostic tests the analog loop at 5 points:

- 4 mA
- 12 mA
- 20 mA
- Low alarm level
- High alarm level

SMART METER VERIFICATION (8714I)

The Smart Meter Verification (8714i) diagnostic provides a means of verifying the flowmeter is within calibration without removing the sensor from the process. This diagnostic test provides a review of the transmitter and sensor's critical parameters as a means to document verification of calibration. The results of running this diagnostic provide the deviation amount from expected values and a pass/fail summary against user-defined criteria for the application and conditions. The Smart Meter Verification diagnostic can be configured to run continuously in the background during normal operation, or it can be manually initiated as required by the application.

Run Smart Meter Verification (8714i)

| | |
|-----------|---|
| Fast Keys | 1, 2, 3, 2, 1 |
| LOI Menu | Diagnostics, Advanced Diag, 8714i, Run 8714i |
| AMS Tab | Context Menu, Diagnostics and Tests, 8714i Calibration Verification |

The Smart Meter Verification diagnostic will be available, if the advanced diagnostic suite (DA2) was ordered. If DA2 was not ordered or licensed, this diagnostic will not be available. This method will initiate the manual meter verification test.

Sensor Signature Parameters

The sensor signature describes the magnetic behavior of the sensor. Based on Faraday’s law, the induced voltage measured on the electrodes is proportional to the magnetic field strength. Thus, any changes in the magnetic field will result in a calibration shift of the sensor.

Establishing the baseline sensor signature

The first step in running the Smart Meter Verification (8714i) test is establishing the reference signature that the test will use as the baseline for comparison. This is accomplished by having the transmitter take a signature of the sensor.

Re-Signature Meter

| | |
|-----------|---|
| Fast Keys | 1, 2, 3, 2, 3, 2 |
| LOI Menu | Diagnostics, Advanced Diag, 8714i, Tube Signature, Re-Signature |
| AMS Tab | Context Menu, Diagnostics and Tests |

Having the transmitter take an initial sensor signature when first installed will provide the baseline for the verification tests that are done in the future. The sensor signature should be taken during the start-up process when the transmitter is first connected to the sensor, with a full line, and ideally with no flow in the line. Running the sensor signature procedure when there is flow in the line is permissible, but this may introduce some noise into the signature measurements. If an empty pipe condition exists, then the sensor signature should only be run for the coils.

Once the sensor signature process is complete, the measurements taken during this procedure are stored in non-volatile memory to prevent loss in the event of a power interruption to the meter. This initial sensor signature is required for both manual and continuous Smart Meter Verification.

Smart Meter Verification (8714i) Test Parameters

The Smart Meter Verification (8714i) diagnostic has a multitude of parameters that set the test criteria, test conditions, and scope of the calibration verification test.

Test Conditions for the Smart Meter Verification (8714i)

There are three possible test conditions that the Smart Meter Verification test can be initiated under. This parameter is set at the time that the Sensor Signature or Smart Meter Verification test is manually initiated.

No Flow

Run the Smart Meter Verification (8714i) test with a full pipe and no flow in the line. Running the Smart Meter Verification test under this condition provides the most accurate results and the best indication of magnetic flowmeter health.

Flowing, Full

Run the Smart Meter Verification (8714i) test with a full pipe and flow in the line. Running the Smart Meter Verification test under this condition provides the ability to verify the magnetic flowmeter health without shutting down the process flow in applications where a shutdown is not possible. Running the calibration verification under flowing conditions can cause false fails if the flow rate is not at a steady flow, or if there is process noise present.

Empty Pipe

Run the Smart Meter Verification (8714i) test with an empty pipe. Running the Smart Meter Verification test under this condition provides the ability to verify the magnetic flowmeter health with an empty pipe. Running the calibration verification under empty pipe conditions will not check the electrode circuit health.

Smart Meter Verification (8714i) Test Criteria

The Smart Meter Verification (8714i) diagnostic provides the ability for the user to define the test criteria that the verification must test to. The test criteria can be set for each of the flow conditions discussed above. This parameter applies to manually initiated test only.

Set Pass/Fail Criteria

| | |
|-----------|--|
| Fast Keys | 1, 2, 3, 2, 4 |
| LOI Menu | Diagnostics, Advanced Diag, 8714i, Test Criteria |
| AMS Tab | 8714i |

No Flow Limit

Set the test criteria for the No Flow condition. The factory default for this value is set to two percent with limits configurable between one and ten percent. This parameter applies to manually initiated test only.

| | |
|-----------|---|
| Fast Keys | 1, 2, 3, 2, 4, 1 |
| LOI Menu | Diagnostics, Advanced Diag, 8714i, Test Criteria, No Flow |
| AMS Tab | 8714i |

Flowing, Full Limit

Set the test criteria for the Flowing, Full condition. The factory default for this value is set to three percent with limits configurable between one and ten percent. This parameter applies to manually initiated tests only.

| | |
|-----------|--|
| Fast Keys | 1, 2, 3, 2, 4, 2 |
| LOI Menu | Diagnostics, Advanced Diag, 8714i, Test Criteria, Flowing Full |
| AMS Tab | 8714i |

Empty Pipe Limit

Set the test criteria for the Empty Pipe condition. The factory default for this value is set to three percent with limits configurable between one and ten percent. This parameter applies to manually initiated test only.

| | |
|-----------|--|
| Fast Keys | 1, 2, 3, 2, 4, 3 |
| LOI Menu | Diagnostics, Advanced Diag, 8714i, Test Criteria, Empty Pipe |
| AMS Tab | 8714i |

Continuous Limit

Set the test criteria for the Continuous Smart Meter Verification diagnostic. The factory default for this value is set to five percent with limits configurable between one and ten percent. If the tolerance band is set too tightly, under empty pipe conditions or noisy flowing conditions, a false failure of the transmitter test may occur.

| | |
|-----------|--|
| Fast Keys | 1, 2, 3, 2, 4, 4 |
| LOI Menu | Diagnostics, Advanced Diag, 8714i, Test Criteria, Continuous |
| AMS Tab | 8714i |

Manual Smart Meter Verification (8714i) Test Scope

The manually initiated Smart Meter Verification (8714i) test can be used to verify the entire flowmeter installation or individual parts such as the transmitter or sensor. This parameter is set at the time that the Smart Meter Verification test is manually initiated.

All

Run the Smart Meter Verification (8714i) test and verify the entire flowmeter installation. This parameter results in the calibration verification performing the transmitter calibration verification, tube calibration verification, coil health check, and electrode health check. Transmitter calibration and tube calibration are verified to the percentage associated with the test condition selected when the test was initiated. This setting applies to manually initiated test only.

| | |
|-----------|---|
| Fast Keys | 1, 2, 3, 2, 2, 1, 1, -- ⁽¹⁾ |
| LOI Menu | Diagnostics, Advanced Diag, 8714i, Run 8714i |
| AMS | Context Menu, Diagnostics and Tests, 8714i Calibration Verification |

Transmitter

Run the Smart Meter Verification (8714i) test on the transmitter only. This results in the verification test only checking the transmitter calibration to the limits of the test criteria selected when the 8714i Calibration Verification test was initiated. This setting applies to manually initiated test only.

| | |
|-----------|---|
| Fast Keys | 1, 2, 3, 2, 2, 1, 1, -- ⁽¹⁾ |
| LOI Menu | Diagnostics, Advanced Diag, 8714i, Run 8714i |
| AMS | Context Menu, Diagnostics and Tests, 8714i Calibration Verification |

Sensor

Run the Smart Meter Verification (8714i) test on the sensor only. This results in the verification test checking the sensor calibration to the limits of the test criteria selected when the Smart Meter Verification test was initiated, verifying the coil circuit health, and the electrode circuit health. This setting applies to manually initiated test only.

| | |
|-----------|---|
| Fast Keys | 1, 2, 3, 2, 2, 1, 1, -- ⁽¹⁾ |
| LOI Menu | Diagnostics, Advanced Diag, 8714i, Run 8714i |
| AMS | Context Menu, Diagnostics and Tests, 8714i Calibration Verification |

(1) This item is in a list format without numeric labels.

Continuous Smart Meter Verification (8714i) Scope

Continuous Smart Meter Verification can be used to monitor and verify the health of the sensor coils, electrodes, transmitter calibration, and analog output. All of these parameters can be individually enabled or disabled. The Continuous Meter Verification will not report results until 30 minutes after powering up to ensure the system is stable and avoid false failures. These parameters apply to Continuous Smart Meter Verification only.

| | |
|-----------|---|
| Fast Keys | 1, 2, 1, 3 |
| LOI Menu | Diagnostics, Diag Controls, Electrode Coating |
| AMS Tab | Diagnostics |

Coils

Continuously monitor the sensor coil circuit by enabling this Continuous Smart Meter Verification parameter.

| | |
|-----------|---|
| Fast Keys | 1, 2, 1, 3, 1 |
| LOI Menu | Diagnostics, Diag Controls, Cont Meter Ver, Coils |
| AMS Tab | Diagnostics |

Electrodes

Continuously monitor the electrode resistance by enabling this Continuous Smart Meter Verification parameter.

| | |
|-----------|---|
| Fast Keys | 1, 2, 1, 3, 2 |
| LOI Menu | Diagnostics, Diag Controls, Cont Meter Ver, Coils |
| AMS Tab | Diagnostics |

Transmitter

Continuously monitor the transmitter calibration by enabling this Continuous Smart Meter Verification parameter.

| | |
|-----------|---|
| Fast Keys | 1, 2, 1, 3, 3 |
| LOI Menu | Diagnostics, Diag Controls, Cont Meter Ver, Transmitter |
| AMS Tab | Diagnostics |

Analog Output

Continuously monitor the analog output signal by enabling this Continuous Smart Meter Verification parameter.

| | |
|-----------|---|
| Fast Keys | 1, 2, 1, 3, 4 |
| LOI Menu | Diagnostics, Diag Controls, Cont Meter Ver, Analog Output |
| AMS Tab | Diagnostics |

Smart Meter Verification (8714i) Test Results Parameters

If the Smart Meter Verification (8714i) test is manually initiated, the transmitter will make several measurements to verify the transmitter calibration, sensor calibration, coil circuit health, and electrode circuit health. The results of these tests can be reviewed and recorded on the calibration verification report found on page C-22. This report can be used to validate that the meter is within the required calibration limits to comply with governmental regulatory agencies.

Viewing the Smart Meter Verification (8714i) Results

Depending on the method used to view the results, they will be displayed in either a menu structure, as a method, or in the report format. When using the HART Field Communicator, each individual component can be viewed as a menu item. When using the LOI, the parameters are viewed as a method using the left arrow key to cycle through the results. In AMS the calibration report is populated with the necessary data eliminating the need to manually complete the report found on page C-22.

NOTE

When using AMS there are two possible methods that can be used to print the report.

Method one involves taking a Print Screen picture of the Smart Meter Verification Report tab on the status screen and pasting it into a word processing program. The Print Screen button will capture all items on the screen so the image will need to be cropped and resized in order to get only the report.

Method two involves using the print feature within AMS while on the status screen. This will result in a printout of all of the information stored on the status tabs. Page two of the report will contain all of the necessary calibration verification result data.

The results are displayed in the order found in the table below. These parameters are explained in more detail in the text that follows. Manual results are listed in order followed by Continual results. Note that the Manual results and Continual results share some parameters, so the shared parameters will be out of order for the Continual results section.

| | Manual Results | Continual Results |
|----|-------------------------------|----------------------|
| 1 | Test Condition | Continuous Limit |
| 2 | Test Criteria | Simulated Velocity |
| 3 | 8714i Test Result | Actual Velocity |
| 4 | Simulated Velocity | Velocity Deviation |
| 5 | Actual Velocity | Coil Signature |
| 6 | Velocity Deviation | Sensor Cal Deviation |
| 7 | Xmter Cal Test Result | Coil Resistance |
| 8 | Sensor Cal Deviation | Electrode Resistance |
| 9 | Sensor Cal Test Result | mA Expected |
| 10 | Coil Circuit Test Result | mA Actual |
| 11 | Electrode Circuit Test Result | mA Deviation |

Test Condition

Review the test condition that the Smart Meter Verification (8714i) test was performed under. This setting applies to manually initiated test only.

| | |
|-----------|---|
| Fast Keys | Manual: 1, 2, 3, 2, 2, 1, 1 |
| LOI Menu | Diagnostics, Advanced Diag, 8714i, View Results, Manual Results |
| AMS | Context Menu, Device Diagnostics, 8714i Report |

Test Criteria

Review the test criteria used to determine the results of the calibration verification tests. This setting applies to manually initiated test only.

| | |
|-----------|---|
| Fast Keys | Manual: 1, 2, 3, 2, 2, 1, 2 |
| LOI Menu | Diagnostics, Advanced Diag, 8714i, View Results, Manual Results |
| AMS | Context Menu, Device Diagnostics, 8714i Report |

8714i Test Result

Displays the overall result of the Smart Meter Verification (8714i) test as either a Pass or Fail. This setting applies to manually initiated test only.

| | |
|-----------|---|
| Fast Keys | Manual: 1, 2, 3, 2, 2, 1, 3 |
| LOI Menu | Diagnostics, Advanced Diag, 8714i, View Results, Manual Results |
| AMS | Context Menu, Device Diagnostics, 8714i Report |

Simulated Velocity

Displays the simulated velocity used to verify the transmitter calibration.

| | |
|-----------|---|
| Fast Keys | Manual: 1, 2, 3, 2, 2, 1, 4; Continuous: 1, 2, 3, 2, 2, 2, 2 |
| LOI Menu | Diagnostics, Advanced Diag, 8714i, View Results, Manual Results, or Continual Results |
| AMS | Context Menu, Device Diagnostics, 8714i Report |

Actual Velocity

Displays the velocity measured by the transmitter during the transmitter calibration verification process.

| | |
|-----------|---|
| Fast Keys | Manual: 1, 2, 3, 2, 2, 1, 5; Continuous: 1, 2, 3, 2, 2, 2, 3 |
| LOI Menu | Diagnostics, Advanced Diag, 8714i, View Results, Manual Results, or Continual Results |
| AMS | Context Menu, Device Diagnostics, 8714i Report |

Velocity Deviation

Displays the deviation in the actual velocity compared to the simulated velocity in terms of a percentage. This percentage is then compared to the test criteria to determine if the transmitter is within calibration limits.

| | |
|-----------|---|
| Fast Keys | Manual: 1, 2, 3, 2, 2, 1, 6; Continuous: 1, 2, 3, 2, 2, 2, 4 |
| LOI Menu | Diagnostics, Advanced Diag, 8714i, View Results, Manual Results, or Continual Results |
| AMS | Context Menu, Device Diagnostics, 8714i Report |

Transmitter Calibration Verification Test Result

Displays the results of the transmitter calibration verification test as either a Pass or Fail. This parameter applies to manually initiated test only.

| | |
|-----------|---|
| Fast Keys | Manual: 1, 2, 3, 2, 2, 1, 7 |
| LOI Menu | Diagnostics, Advanced Diag, 8714i, View Results, Manual Results |
| AMS | Context Menu, Device Diagnostics, 8714i Report |

Sensor Calibration Deviation

Displays the deviation in the sensor calibration. This value tells how much the sensor calibration has shifted from the original baseline signature. This percentage is compared to the test criteria to determine if the sensor is within calibration limits.

| | |
|-----------|---|
| Fast Keys | Manual: 1, 2, 3, 2, 2, 1, 8; Continuous: 1, 2, 3, 2, 2, 2, 6 |
| LOI Menu | Diagnostics, Advanced Diag, 8714i, View Results, Manual Results, or Continual Results |
| AMS | Context Menu, Device Diagnostics, 8714i Report |

Sensor Calibration Test Result

Displays the results of the sensor calibration verification test as either a Pass or Fail. This parameter applies to manually initiated test only.

| | |
|-----------|---|
| Fast Keys | Manual: 1, 2, 3, 2, 1, 9 |
| LOI Menu | Diagnostics, Advanced Diag, 8714i, View Results, Manual Results |
| AMS | Context Menu, Device Diagnostics, 8714i Report |

Coil Circuit Test Result

Displays the results of the coil circuit health check as either a Pass or Fail. This parameter applies to manually initiated test only.

| | |
|-----------|---|
| Fast Keys | Manual: 1, 2, 3, 2, 2, 1, 10 ⁽¹⁾ |
| LOI Menu | Diagnostics, Advanced Diag, 8714i, View Results, Manual Results |
| AMS | Context Menu, Device Diagnostics, 8714i Report |

Electrode Circuit Test Result

Displays the results of the electrode circuit health check as either a Pass or Fail. This parameter applies to manually initiated test only.

| | |
|-----------|---|
| Fast Keys | Manual: 1, 2, 3, 2, 2, 1, 11 ⁽¹⁾ |
| LOI Menu | Diagnostics, Advanced Diag, 8714i, View Results, Manual Results |
| AMS | Context Menu, Device Diagnostics, 8714i Report |

Continual Limit

Review the test criteria used to determine the results of the Continuous Smart Meter Verification diagnostic. This parameter applies to Continuous Smart Meter Verification only.

| | |
|-----------|--|
| Fast Keys | Continuous: 1, 2, 3, 2, 2, 2, 1 |
| LOI Menu | Diagnostics, Advanced Diag, 8714i, View Results, Continual Results |
| AMS Tab | Configure/Setup, 8714i, Automatic 8714i Results |

Coil Signature

Displays the Coil Signature used to verify the magnetic field strength. This value is compared to the coil signature baseline measurement taken during the sensor signature process to determine tube calibration deviation. This parameter applies to Continuous Smart Meter Verification only.

| | |
|-----------|--|
| Fast Keys | Continuous: 1, 2, 3, 2, 2, 2, 5 |
| LOI Menu | Diagnostics, Advanced Diag, 8714i, View Results, Continual Results |
| AMS Tab | Configure/Setup, 8714i, Automatic 8714i Results |

(1) To get to this value, the down arrow must be used to scroll through the menu list.

Coil Resistance

Displays the Coil Resistance value used to verify the coil circuit health. This value is compared to the coil circuit resistance baseline measurement taken during the sensor signature process to determine coil circuit health. This parameter applies to Continuous Smart Meter Verification only.

| | |
|-----------|--|
| Fast Keys | Continuous: 1, 2, 3, 2, 2, 2, 7 |
| LOI Menu | Diagnostics, Advanced Diag, 8714i, View Results, Continual Results |
| AMS Tab | Configure/Setup, 8714i, Automatic 8714i Results |

Electrode Resistance

Displays the Electrode Resistance value used to verify the electrode circuit health. This value is compared to the electrode circuit resistance baseline measurement taken during the sensor signature process to determine electrode circuit health. This parameter applies to Continuous Smart Meter Verification only.

| | |
|-----------|--|
| Fast Keys | Continuous: 1, 2, 3, 2, 2, 2, 8 |
| LOI Menu | Diagnostics, Advanced Diag, 8714i, View Results, Continual Results |
| AMS Tab | Configure/Setup, 8714i, Automatic 8714i Results |

mA Expected

Displays the simulated mA output used to verify the transmitter calibration. This parameter applies to Continuous Smart Meter Verification only.

| | |
|-----------|--|
| Fast Keys | Continuous: 1, 2, 3, 2, 2, 2, 9 |
| LOI Menu | Diagnostics, Advanced Diag, 8714i, View Results, Continual Results |
| AMS Tab | Configure/Setup, 8714i, Automatic 8714i Results |

mA Actual

Displays the mA output sent by the transmitter during the transmitter calibration verification process. This parameter applies to Continuous Smart Meter Verification only.

| | |
|-----------|--|
| Fast Keys | Continuous: 1, 2, 3, 2, 2, 2, 10 ⁽¹⁾ |
| LOI Menu | Diagnostics, Advanced Diag, 8714i, View Results, Continual Results |
| AMS Tab | Configure/Setup, 8714i, Automatic 8714i Results |

mA Deviation

Displays the deviation in the actual mA output compared to the simulated mA output in terms of a percentage. This percentage is then compared to the test criteria to determine if the transmitter is within calibration limits. This parameter applies to Continuous Smart Meter Verification only.

| | |
|-----------|--|
| Fast Keys | Continuous: 1, 2, 3, 2, 2, 2, 11 ⁽¹⁾ |
| LOI Menu | Diagnostics, Advanced Diag, 8714i, View Results, Continual Results |
| AMS Tab | Configure/Setup, 8714i, Automatic 8714i Results |

(1) To access these features, you must scroll to this option in the HART Field Communicator

Optimizing the Smart Meter Verification (8714i)

The Smart Meter Verification (8714i) diagnostic can be optimized by setting the test criteria to the desired levels necessary to meet the compliance requirements of the application. The following examples below will provide some guidance on how to set these levels.

(1) To get to this value, the down arrow must be used to scroll through the menu list.

Example

An effluent meter must be certified annually to comply with environmental regulations. This example regulation requires that the meter be certified to five percent.

Since this is an effluent meter, shutting down the process may not be viable. In this instance the Smart Meter Verification test will be performed under flowing conditions. Set the test criteria for Flowing, Full to five percent to meet the requirements of the governmental agencies.

Example

A pharmaceutical company requires bi-annual verification of meter calibration on a critical feed line for one of their products. This is an internal standard, but plant requirements require a calibration record be kept on-hand. Meter calibration on this process must meet one percent. The process is a batch process so it is possible to perform the calibration verification with the line full and with no flow.

Since the Smart Meter (8714i) test can be run under no flow conditions, set the test criteria for No Flow to one percent to comply with the necessary plant standards.

Example

A food and beverage company requires an annual calibration of a meter on a product line. The plant standard calls for the accuracy to be three percent or better. They manufacture this product in batches, and the measurement cannot be interrupted when a batch is in process. When the batch is complete, the line goes empty.

Since there is no means of performing the Smart Meter Verification (8714i) test while there is product in the line, the test must be performed under empty pipe conditions. The test criteria for Empty Pipe should be set to three percent, and it should be noted that the electrode circuit health cannot be verified.

Optimizing Continuous Smart Meter Verification

Example

For continuous meter verification, there is only one test criteria value to configure, and it will be used for all flow conditions. The factory default is set to five percent to minimize the potential for false failures under empty pipe conditions. For best results, set the criteria to match the maximum value of the three test criteria set during manual meter verification (No Flow, Flowing Full, and Empty Pipe).

For example, a plant might set the following manual meter verification test criteria: two percent for No Flow, three percent for Flowing Full, and four percent for Empty Pipe. In this case, the maximum test criteria is four percent, so the test criteria for continuous meter verification should be set to four percent. If the tolerance band is set too tightly, under empty pipe conditions or noisy flowing conditions, a false failure of the transmitter test may occur.

Troubleshooting the Smart Meter Verification (8714i) Test

In the event that the Smart Meter Verification (8714i) test fails, the following steps can be used to determine the appropriate course of action. Begin by reviewing the Smart Meter Verification (8714i) results to determine the specific test that failed.

Rosemount 8732

Figure C-1. Troubleshooting the 8714i Calibration Verification Test Table

| Test | Potential Causes of Failure | Steps to Correct |
|--|--|--|
| Transmitter Calibration Verification Test Failed | <ul style="list-style-type: none"> • Unstable flow rate during the verification test • Noise in the process • Transmitter drift • Faulty electronics | <ul style="list-style-type: none"> • Perform the test with no flow in the pipe • Check calibration with an external standard like the 8714D • Perform a digital trim • Replace the electronics |
| Sensor Calibration Verification Failed | <ul style="list-style-type: none"> • Moisture in the terminal block of the sensor • Calibration shift caused by heat cycling or vibration | <ul style="list-style-type: none"> • Perform the sensor checks detailed in step 3 of Quick Troubleshooting guide on page 6-9. • Remove the sensor and send back for evaluation and recalibration. |
| Coil Circuit Health Failed | <ul style="list-style-type: none"> • Moisture in the terminal block of the sensor • Shorted Coil | <ul style="list-style-type: none"> • Perform the sensor checks detailed in step 3 of Quick Troubleshooting guide on page 6-9. |
| Electrode Circuit Health Failed | <ul style="list-style-type: none"> • Moisture in the terminal block of the sensor • Coated Electrodes • Shorted Electrodes | <ul style="list-style-type: none"> • Perform the sensor checks detailed in step 3 of Quick Troubleshooting guide on page 6-9. |

Smart Meter Verification (8714i) Functionality

The Smart Meter Verification (8714i) diagnostic functions by taking a baseline sensor signature and then comparing measurements taken during the verification test to these baseline results.

Sensor Signature Values

The sensor signature describes the magnetic behavior of the sensor. Based on Faraday's law, the induced voltage measured on the electrodes is proportional to the magnetic field strength. Thus, any changes in the magnetic field will result in a calibration shift of the sensor. Having the transmitter take an initial sensor signature when first installed will provide the baseline for the verification tests that are done in the future. There are three specific measurements that are stored in the transmitter's non-volatile memory that are used when performing the calibration verification.

Coil Circuit Resistance

The Coil Circuit Resistance is a measurement of the coil circuit health. This value is used as a baseline to determine if the coil circuit is still operating correctly when the Smart Meter Verification (8714i) diagnostic is initiated.

| | |
|-----------|---|
| Fast Keys | 1, 2, 3, 2, 3, 1, 1 |
| LOI Menu | Diagnostics, Advanced Diag, 8714i, Snsr Signature, Values |
| AMS | |

Coil Signature

The Coil Signature is a measurement of the magnetic field strength. This value is used as a baseline to determine if a sensor calibration shift has occurred when the Smart Meter Verification (8714i) diagnostic is initiated.

| | |
|-----------|---|
| Fast Keys | 1, 2, 3, 2, 3, 1, 2 |
| LOI Menu | Diagnostics, Advanced Diag, 8714i, Snsr Signature, Values |
| AMS | |

Electrode Circuit Resistance

The Electrode Circuit Resistance is a measurement of the electrode circuit health. This value is used as a baseline to determine if the electrode circuit is still operating correctly when the Smart Meter Verification diagnostic is initiated.

| | |
|-----------|---|
| Fast Keys | 1, 2, 3, 2, 3, 1, 3 |
| LOI Menu | Diagnostics, Advanced Diag, 8714i, Snsr Signature, Values |
| AMS | |

Smart Meter Verification (8714i) Measurements

The Smart Meter Verification (8714i) test will make measurements of the coil resistance, coil signature, and electrode resistance and compare these values to the values taken during the sensor signature process to determine the sensor calibration deviation, the coil circuit health, and the electrode circuit health. In addition, the measurements taken by this test can provide additional information when troubleshooting the meter.

Coil Circuit Resistance

The Coil Circuit Resistance is a measurement of the coil circuit health. This value is compared to the coil circuit resistance baseline measurement taken during the sensor signature process to determine coil circuit health. This value can be continuously monitored using Continuous Smart Meter Verification.

| | |
|-----------|--|
| Fast Keys | Manual: 1, 2, 3, 2, 5, 1, 1: Continuous: 1, 2, 3, 2, 5, 2, 1 |
| LOI Menu | Diagnostics, Advanced Diag, 8714i, View Results, Manual Results or Continual Res |
| AMS | |

Coil Signature

The Coil Signature is a measurement of the magnetic field strength. This value is compared to the coil signature baseline measurement taken during the sensor signature process to determine tube calibration deviation. This value can be continuously monitored using Continuous Smart Meter Verification.

| | |
|-----------|--|
| Fast Keys | Manual: 1, 2, 3, 2, 5, 1, 2: Continuous: 1, 2, 3, 2, 5, 2, 2 |
| LOI Menu | Diagnostics, Advanced Diag, 8714i, View Results, Manual Results or Continual Res |
| AMS | |

Electrode Circuit Resistance

The Electrode Circuit Resistance is a measurement of the electrode circuit health. This value is compared to the electrode circuit resistance baseline measurement taken during the sensor signature process to determine electrode circuit health. This value can be continuously monitored using Continuous Smart Meter Verification.

| | |
|-----------|--|
| Fast Keys | Manual: 1, 2, 3, 2, 5, 1, 3: Continuous: 1, 2, 3, 2, 5, 2, 3 |
| LOI Menu | Diagnostics, Advanced Diag, 8714i, View Results, Manual Results or Continual Res |
| AMS | |

CALIBRATION VERIFICATION REPORT

| Calibration Verification Report Parameters | |
|---|---|
| User Name: _____ | Calibration Conditions: <input type="checkbox"/> Internal <input type="checkbox"/> External |
| Tag #: _____ | Test Conditions: <input type="checkbox"/> Flowing <input type="checkbox"/> No Flow, Full Pipe <input type="checkbox"/> Empty Pipe |
| Flowmeter Information and Configuration | |
| Software Tag: _____ | PV URV (20 mA scale): _____ |
| Calibration Number: _____ | PV LRV (4 mA scale): _____ |
| Line Size: _____ | PV Damping: _____ |
| Transmitter Calibration Verification Results | Sensor Calibration Verification Results |
| Simulated Velocity: _____ | Sensor Deviation %: _____ |
| Actual Velocity: _____ | Sensor Test: <input type="checkbox"/> PASS / <input type="checkbox"/> FAIL / <input type="checkbox"/> NOT TESTED |
| Deviation %: _____ | Coil Circuit Test: <input type="checkbox"/> PASS / <input type="checkbox"/> FAIL / <input type="checkbox"/> NOT TESTED |
| Transmitter: <input type="checkbox"/> PASS / <input type="checkbox"/> FAIL / <input type="checkbox"/> NOT TESTED | Electrode Circuit Test: <input type="checkbox"/> PASS / <input type="checkbox"/> FAIL / <input type="checkbox"/> NOT TESTED |
| Summary of Calibration Verification Results | |
| Verification Results: The result of the flowmeter verification test is: <input type="checkbox"/> PASSED / <input type="checkbox"/> FAILED | |
| Verification Criteria: This meter was verified to be functioning within _____ % of deviation from the original test parameters. | |
| Signature: _____ | Date: _____ |

Appendix D Digital Signal Processing

| | |
|-----------------------|----------|
| Safety Messages | page D-1 |
| Procedures | page D-2 |

SAFETY MESSAGES

Instructions and procedures in this section may require special precautions to ensure the safety of the personnel performing the operations. Please read the following safety messages before performing any operation described in this section.

Warnings

| |
|--|
| <p style="text-align: center;">⚠ WARNING</p> <p>Explosions could result in death or serious injury:</p> <ul style="list-style-type: none">• Verify that the operating atmosphere of the sensor and transmitter is consistent with the appropriate hazardous locations certifications.• Do not remove the transmitter cover in explosive atmospheres when the circuit is alive.• Before connecting a HART-based communicator in an explosive atmosphere, make sure the instruments in the loop are installed in accordance with intrinsically safe or non-incendive field wiring practices.• Both transmitter covers must be fully engaged to meet explosion-proof requirements. |
| <p style="text-align: center;">⚠ WARNING</p> <p>Failure to follow safe installation and servicing guidelines could result in death or serious injury:</p> <ul style="list-style-type: none">• Make sure only qualified personnel perform the installation.• Do not perform any service other than those contained in this manual unless qualified. <p>Process leaks could result in death or serious injury:</p> <ul style="list-style-type: none">• The electrode compartment may contain line pressure; it must be depressurized before the cover is removed. |
| <p style="text-align: center;">⚠ WARNING</p> <p>High voltage that may be present on leads could cause electrical shock:</p> <ul style="list-style-type: none">• Avoid contact with leads and terminals. |

Rosemount 8732

PROCEDURES

If the output of your Rosemount 8732 is unstable, first check the wiring and grounding associated with the magnetic flowmeter system. Ensure that the following conditions are met:

- Ground straps are attached to the adjacent flange or ground ring?
- Grounding rings, lining protectors, or grounding electrodes are being used in lined or nonconductive piping?
- Both of the shields attached at both ends?

The causes of unstable transmitter output can usually be traced to extraneous voltages on the measuring electrodes. This “process noise” can arise from several causes including electrochemical reactions between the fluid and the electrode, chemical reactions in the process itself, free ion activity in the fluid, or some other disturbance of the fluid/electrode capacitive layer. In such noisy applications, an analysis of the frequency spectrum reveals process noise that typically becomes significant below 15 Hz.

In some cases, the effects of process noise may be sharply reduced by elevating the coil drive frequency above the 15 Hz region. The Rosemount 8732 coil drive mode is selectable between the standard 5 Hz and the noise-reducing 37 Hz. See “Coil Drive Frequency” on page 4-26 for instructions on how to change the coil drive mode to 37 Hz.

Auto Zero

To ensure optimum accuracy when using 37 Hz coil drive mode, there is an auto zero function that must be initiated during start-up. The auto zero operation is also discussed in the start-up and configuration sections. When using 37 Hz coil drive mode it is important to zero the system for the specific application and installation.

The auto zero procedure should be performed only under the following conditions:

- With the transmitter and sensor installed in their final positions. This procedure is not applicable on the bench.
- With the transmitter in 37 Hz coil drive mode. Never attempt this procedure with the transmitter in 5 Hz coil drive mode.
- With the sensor full of process fluid at zero flow.

These conditions should cause an output equivalent to zero flow.

Signal Processing

If the 37 Hz coil drive mode has been set, and the output is still unstable, the damping and signal processing function should be used. It is important to set the coil drive mode to 37 Hz first, so the loop response time is not increased.

The 8732 provides for a very easy and straightforward start-up, and also incorporates the capability to deal with difficult applications that have previously manifested themselves in a noisy output signal. In addition to selecting a higher coil drive frequency (37 Hz vs. 5 Hz) to isolate the flow signal from the process noise, the 8732 microprocessor can actually scrutinize each input based on three user-defined parameters to reject the noise specific to the application.

This software technique, known as signal processing, “qualifies” individual flow signals based on historic flow information and three user-definable parameters, plus an on/off control. These parameters are:

1. Number of samples: The number of samples function sets the amount of time that inputs are collected and used to calculate the average value. Each second is divided into tenths ($1/10$) with the number of samples equaling the number of $1/10$ second increments used to calculate the average. Factory Preset Value = 90 samples.

For example, a value of:

1 averages the inputs over the past $1/10$ second

10 averages the inputs over the past 1 second

100 averages the inputs over the past 10 seconds

125 averages the inputs over the past 12.5 seconds

2. Maximum Percent Limit: The tolerance band set up on either side of the running average, referring to percent deviation from the average. Values within the limit are accepted while value outside the limit are scrutinized to determine if they are a noise spike or an actual flow change. Factory Preset Value = 2 percent.
3. Time Limit: Forces the output and running average values to the new value of an actual flow rate change that is outside the percent limit boundaries, thereby limiting response time to real flow changes to the time limit value rather than the length of the running average. Factory Preset Value = 2 seconds.

How Does It Really Work?

The best way to explain this is with the help of an example, plotting flow rate versus time

Figure D-1. Signal Processing

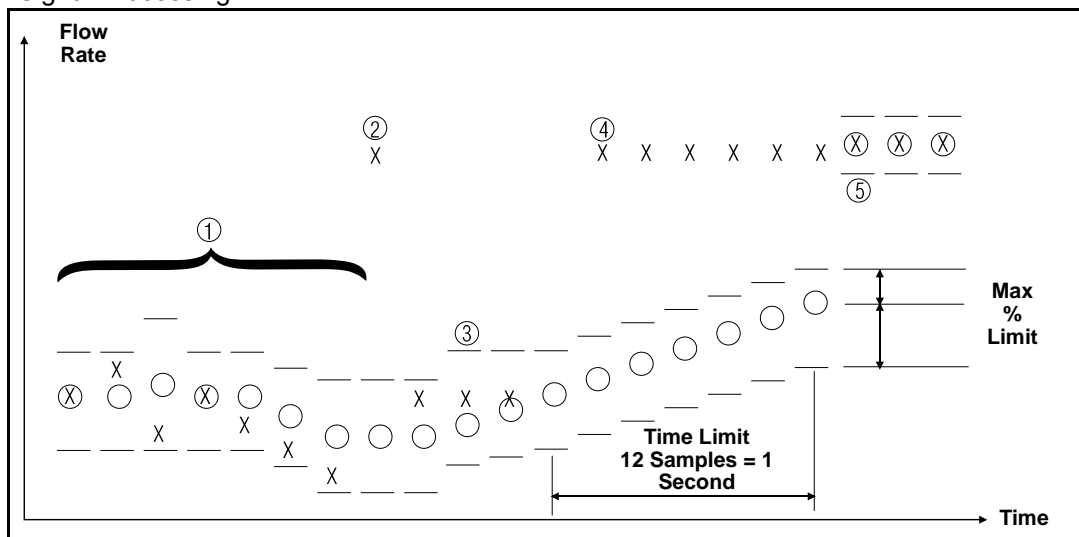

- X: Input flow signal from sensor.
- O: Average flow signals and transmitter output, determined by the “number of samples” parameter.
- Tolerance band, determined by the “percent limit” parameter.
- Upper value = average flow + [(percent limit/100) average flow]
 - Lower value = average flow – [(percent limit/100) average flow]
1. This scenario is that of a typical non-noisy flow. The input flow signal is within the percent limit tolerance band, therefore qualifying itself as a good input. In this case the new input is added directly into the running average and is passed on as a part of the average value to the output.
 2. This signal is outside the tolerance band and therefore is held in memory until the next input can be evaluated. The running average is provided as the output.
 3. The previous signal currently held in memory is simply rejected as a noise spike since the next flow input signal is back within the tolerance band. This results in complete rejection of noise spikes rather than allowing them to be “averaged” with the good signals as occurs in the typical analog damping circuits.
 4. As in Number 2 above, the input is outside the tolerance band. This first signal is held in memory and compared to the next signal. The next signal is also outside the tolerance band (in the same direction), so the stored value is added to the running average as the next input and the running average begins to slowly approach the new input level.
 5. To avoid waiting for the slowly incrementing average value to catch up to the new level input, a shortcut is provided. This is the “time limit” parameter. The user can set this parameter to eliminate the slow ramping of the output toward the new input level.

When Should Signal Processing Be Used?

The Rosemount 8732 offers three separate functions that can be used in series for improving a noisy output. The first step is to toggle the coil drive to the 37 Hz mode and initialize with an auto zero. If the output is still noisy at this stage, signal processing should be actuated and, if necessary, tuned to match the specific application. Finally, if the signal is still too unstable, the traditional damping function can be used.

NOTE

Failure to complete an Auto Zero will result in a small (<1%) error in the output. While the output level will be offset by the error, the repeatability will not be affected.

Appendix E Universal Sensor Wiring Diagrams

| | |
|--|-----------|
| Rosemount Sensors | page E-3 |
| Brooks Sensors | page E-6 |
| Perform the Universal Auto Trim function. | page E-5 |
| Fischer And Porter Sensors | page E-9 |
| Foxboro Sensors | page E-15 |
| Kent Veriflux VTC Sensor | page E-19 |
| Kent Sensors | page E-20 |
| Krohne Sensors | page E-21 |
| Taylor Sensors | page E-22 |
| Yamatake Honeywell Sensors | page E-24 |
| Yokogawa Sensors | page E-25 |
| Generic Manufacturer Sensors | page E-26 |

The wiring diagrams in this section illustrate the proper connections between the Rosemount 8732 and most sensors currently on the market. Specific diagrams are included for most models, and where information for a particular model of a manufacturer is not available, a generic drawing pertaining to that manufacturer's sensors is provided. If the manufacturer for your sensor is not included, see the drawing for generic connections.

Any trademarks used herein regarding sensors not manufactured by Rosemount are owned by the particular manufacturer of the sensor.

| Rosemount Transmitter | Sensor Manufacturer | Page Number |
|------------------------------------|-----------------------------------|-------------|
| Rosemount | | |
| Rosemount 8732 | Rosemount 8705, 8707, 8711 | page E-3 |
| Rosemount 8732 | Rosemount 8701 | page E-4 |
| Brooks | | |
| Rosemount 8732 | Model 5000 | page E-6 |
| Rosemount 8732 | Model 7400 | page E-7 |
| Endress and Hauser | | |
| Rosemount 8732 | Generic Wiring for Sensor | page E-5 |
| Rosemount 8732 | Generic Wiring for Sensor | page E-8 |
| Fischer and Porter | | |
| Rosemount 8732 | Model 10D1418 | page E-9 |
| Rosemount 8732 | Model 10D1419 | page E-9 |
| Rosemount 8732 | Model 10D1430 (Remote) | page E-10 |
| Rosemount 8732 | Model 10D1430 | page E-11 |
| Rosemount 8732 | Model 10D1430 | page E-12 |
| Rosemount 8732 | Model 10D1465, 10D1475 (Integral) | page E-13 |
| Rosemount 8732 | Generic Wiring for Sensors | page E-14 |
| Foxboro | | |
| Rosemount 8732 | Series 1800 | page E-15 |
| Rosemount 8732 | Series 1800 (Version 2) | page E-16 |
| Rosemount 8732 | Series 2800 | page E-17 |
| Rosemount 8732 | Generic Wiring for Sensors | page E-18 |
| Kent | | |
| Rosemount 8732 | Veriflux VTC | page E-19 |
| Rosemount 8732 | Generic Wiring for Sensors | page E-20 |
| Krohne | | |
| Rosemount 8732 | Generic Wiring for Sensors | page E-21 |
| Taylor | | |
| Rosemount 8732 | Series 1100 | page E-23 |
| Rosemount 8732 | Generic Wiring for Sensors | page E-23 |
| Yamatake Honeywell | | |
| Rosemount 8732 | Generic Wiring for Sensors | page E-24 |
| Yokogawa | | |
| Rosemount 8732 | Generic Wiring for Sensors | page E-25 |
| Generic Manufacturer Wiring | | |
| Rosemount 8732 | Generic Wiring for Sensors | page E-26 |

ROSEMOUNT SENSORS

**Rosemount
 8705/8707/8711/8721
 Sensors to Rosemount
 8732 Transmitter**

Connect coil drive and electrode cables as shown in Figure E-1.

Figure E-1. Wiring Diagram to a Rosemount 8732 Transmitter

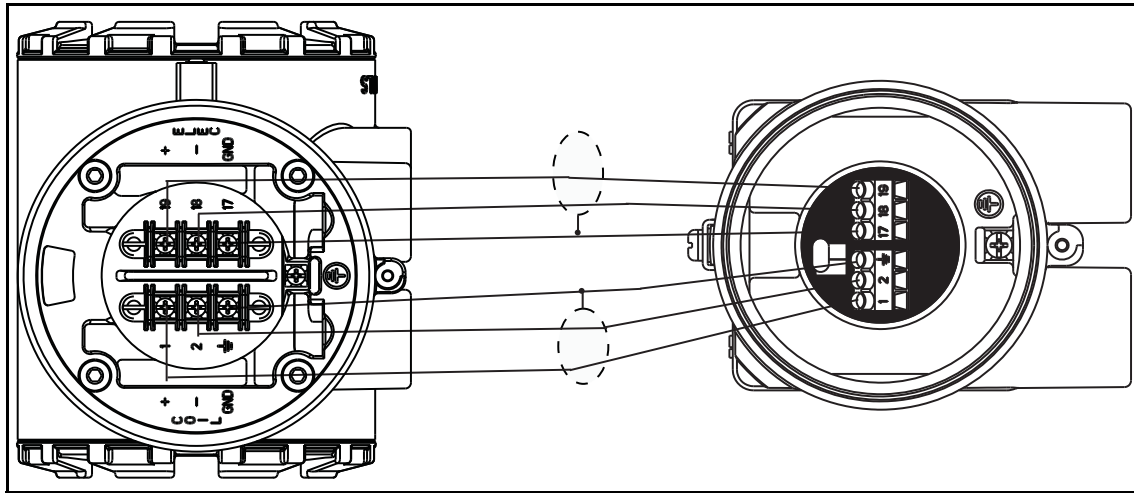

Table E-1. Rosemount 8705/8707/8711/8721 Sensor Wiring Connections

| Rosemount 8732 Transmitters | Rosemount 8705/8707/8711/8721 Sensors |
|-----------------------------|---------------------------------------|
| 1 | 1 |
| 2 | 2 |
| ⏏ | ⏏ |
| 17 | 17 |
| 18 | 18 |
| 19 | 19 |

| ⚠ CAUTION | |
|--|--|
| <p>This is a pulsed DC magnetic flowmeter. Do not connect AC power to the sensor or to terminals 1 and 2 of the transmitter, or replacement of the electronics board will be necessary.</p> | |

Rosemount 8732

Rosemount 8701 Sensor to Rosemount 8732 Transmitter

Connect coil drive and electrode cables as shown in Figure E-2.

Figure E-2. Wiring Diagram for Rosemount 8701 Sensor and Rosemount 8732 Transmitter

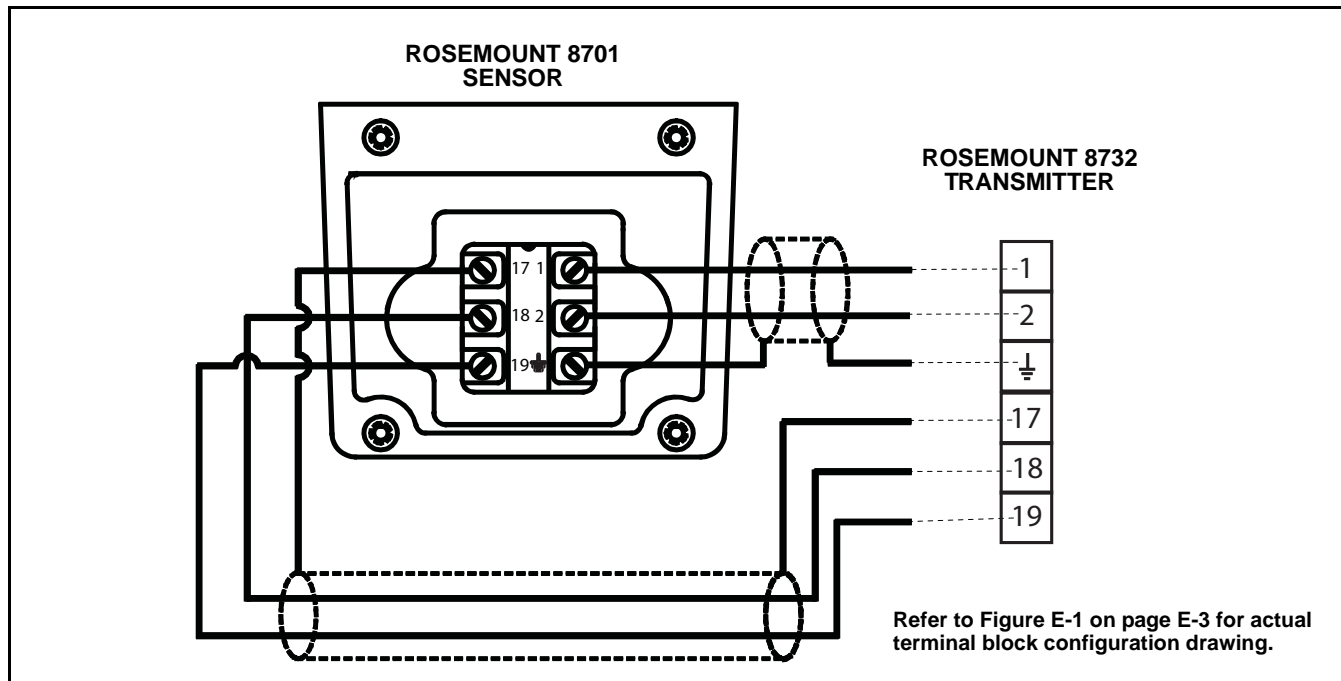

Table E-2. Rosemount 8701 Sensor Wiring Connections

| Rosemount 8732 | Rosemount 8701 Sensors |
|----------------|------------------------|
| 1 | 1 |
| 2 | 2 |
| ⏏ | ⏏ |
| 17 | 17 |
| 18 | 18 |
| 19 | 19 |

⚠ CAUTION

This is a pulsed DC magnetic flowmeter. **Do not connect AC power to the sensor or to terminals 1 and 2 of the transmitter**, or replacement of the electronics board will be necessary.

Connecting Sensors of Other Manufacturers

Before connecting another manufacturer's sensor to the Rosemount 8732 transmitter, it is necessary to perform the following functions.



1. Turn off the AC power to the sensor and transmitter. Failure to do so could result in electrical shock or damage to the transmitter.
2. Verify that the coil drive cables between the sensor and the transmitter are not connected to any other equipment.
3. Label the coil drive cables and electrode cables for connection to the transmitter.
4. Disconnect the wires from the existing transmitter.
5. Remove the existing transmitter. Mount the new transmitter. See "Mount the Transmitter" on page 2-4.
6. Verify that the sensor coil is configured for series connection. Other manufacturers sensors may be wired in either a series or parallel circuit. All Rosemount magnetic sensors are wired in a series circuit. (Other manufacturers AC sensors (AC coils) wired for 220 V operation are typically wired in parallel and must be rewired in series.)
7. Verify that the sensor is in good working condition. Use the manufacturer's recommended test procedure for verification of sensor condition. Perform the basic checks:
 - a. Check the coils for shorts or open circuits.
 - b. Check the sensor liner for wear or damage.
 - c. Check the electrodes for shorts, leaks, or damage.
8. Connect the sensor to the transmitter in accordance with reference wiring diagrams. See Appendix E: Universal Sensor Wiring Diagrams for specific drawings.
9. Connect and verify all connections between the sensor and the transmitter, then apply power to the transmitter.
10. Perform the Universal Auto Trim function.

CAUTION

This is a pulsed DC magnetic flowmeter. **Do not connect AC power to the sensor or to terminals 1 and 2 of the transmitter**, or replacement of the electronics board will be necessary.

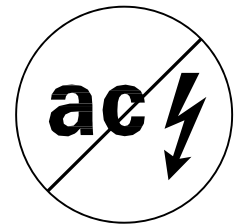

Rosemount 8732

BROOKS SENSORS

Connect coil drive and electrode cables as shown in Figure E-3.

Model 5000 Sensor to Rosemount 8732 Transmitter

Figure E-3. Wiring Diagram for
Brooks Sensor Model 5000 and
Rosemount 8732

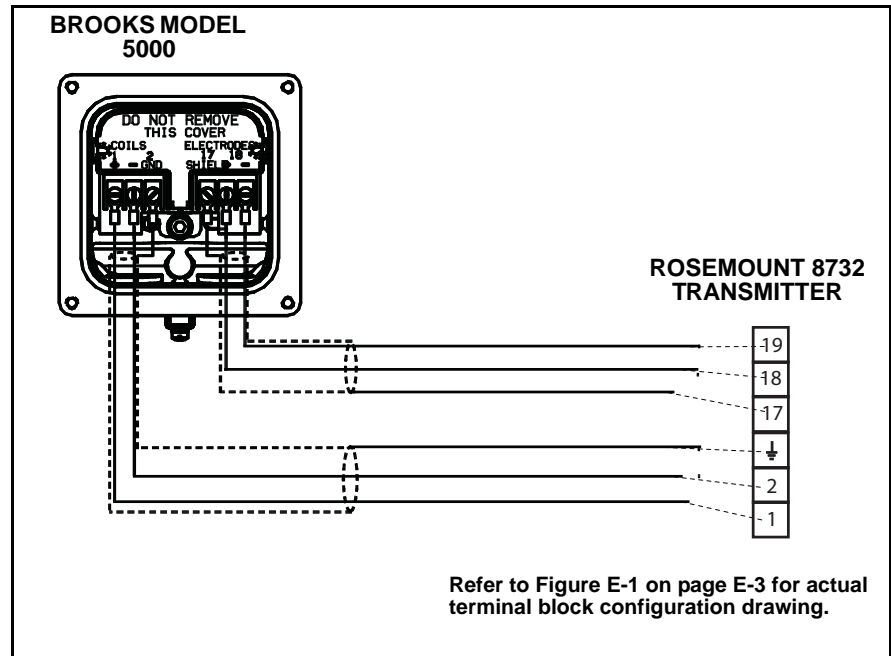

Table E-3. Brooks Model 5000
Sensor Wiring Connections

| Rosemount 8732 | Brooks Sensors Model 5000 |
|----------------|---------------------------|
| 1 | 1 |
| 2 | 2 |
| ⊥ | ⊥ |
| 17 | 17 |
| 18 | 18 |
| 19 | 19 |

⚠ CAUTION

This is a pulsed DC magnetic flowmeter. **Do not connect AC power to the sensor or to terminals 1 and 2 of the transmitter**, or replacement of the electronics board will be necessary.

**Model 7400 Sensor to
 Rosemount 8732
 Transmitter**

Connect coil drive and electrode cables as shown in Figure E-4.

Figure E-4. Wiring Diagram for Brooks Sensor Model 7400 and Rosemount 8732

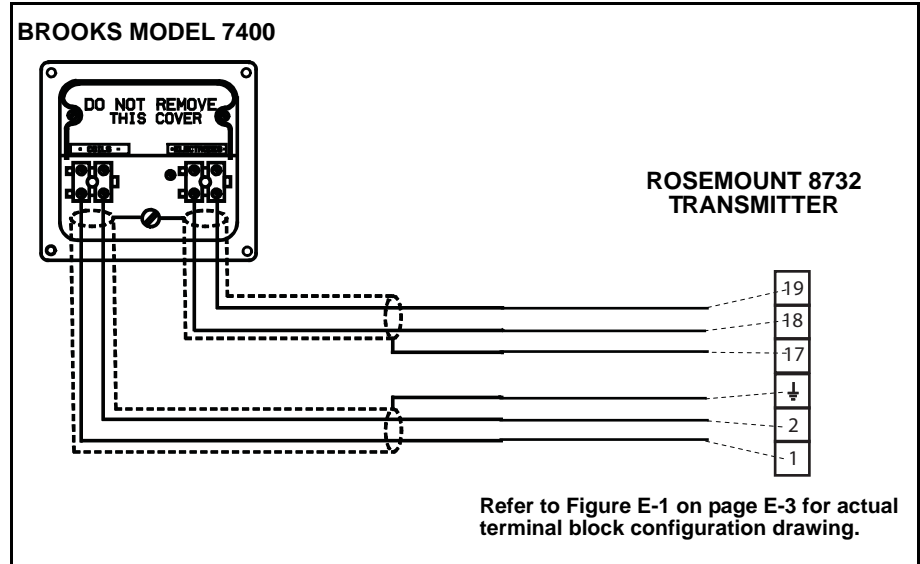

Table E-4. Brooks Model 7400 Sensor Wiring Connections

| Rosemount 8732 | Brooks Sensors Model 7400 |
|----------------|---------------------------|
| 1 | Coils + |
| 2 | Coils - |
| ⊥ | ⊥ |
| 17 | Shield |
| 18 | Electrode + |
| 19 | Electrode - |

⚠ CAUTION

This is a pulsed DC magnetic flowmeter. **Do not connect AC power to the sensor or to terminals 1 and 2 of the transmitter**, or replacement of the electronics board will be necessary.

ENDRESS AND HAUSER SENSORS

Connect coil drive and electrode cables as shown in Figure E-5.

Endress and Hauser Sensor to Rosemount 8732 Transmitter

Figure E-5. Wiring Diagram for Endress and Hauser Sensors and Rosemount 8732

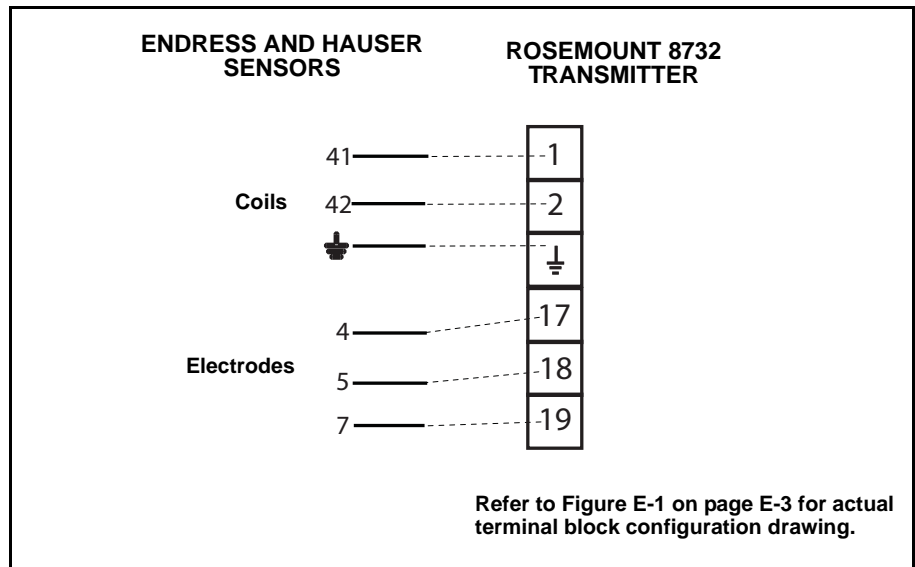

Table E-5. Endress and Hauser Sensor Wiring Connections

| Rosemount 8732 | Endress and Hauser Sensors |
|----------------|----------------------------|
| 1 | 41 |
| 2 | 42 |
| ⏏ | 14 |
| 17 | 4 |
| 18 | 5 |
| 19 | 7 |

⚠ CAUTION

This is a pulsed DC magnetic flowmeter. **Do not connect AC power to the sensor or to terminals 1 and 2 of the transmitter**, or replacement of the electronics board will be necessary.

FISCHER AND PORTER SENSORS

Connect coil drive and electrode cables as shown in Figure E-6.

Model 10D1418 Sensor to Rosemount 8732 Transmitter

Figure E-6. Wiring Diagram for Fischer and Porter Sensor Model 10D1418 and Rosemount 8732

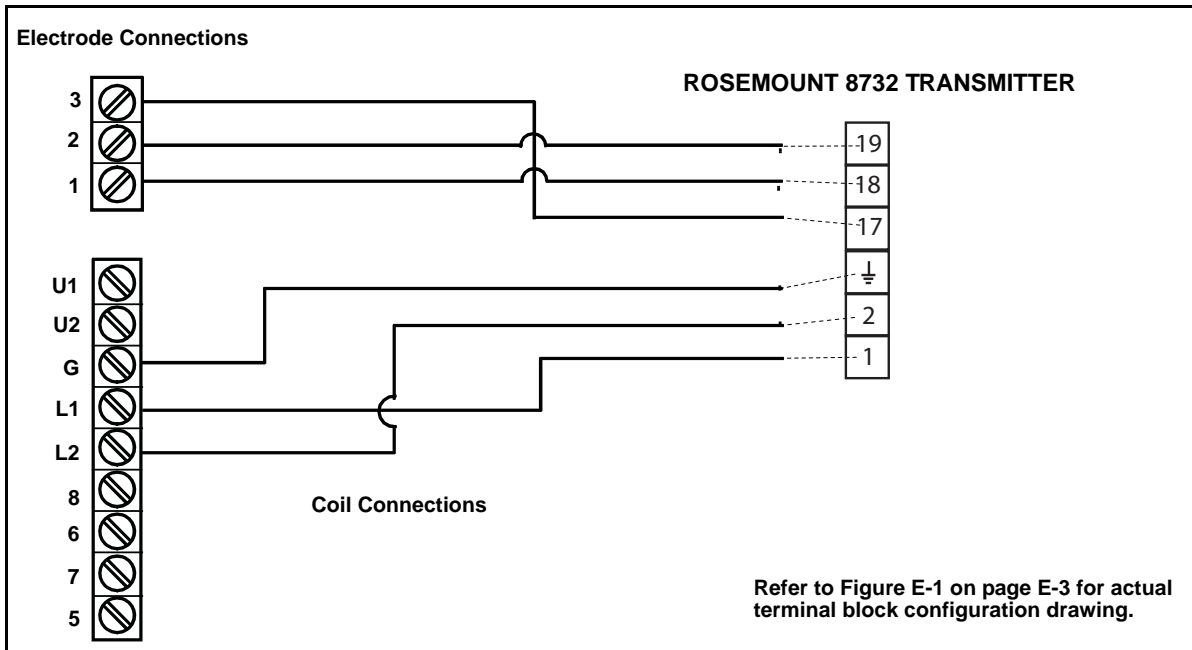

Refer to Figure E-1 on page E-3 for actual terminal block configuration drawing.

Table E-6. Fischer and Porter Model 10D1418 Sensor Wiring Connections

| Rosemount 8732 | Fischer and Porter Model 10D1418 Sensors |
|----------------|--|
| 1 | L1 |
| 2 | L2 |
| ⏏ | Chassis Ground |
| 17 | 3 |
| 18 | 1 |
| 19 | 2 |

CAUTION

This is a pulsed DC magnetic flowmeter. Do not connect AC power to the sensor or to terminals 1 and 2 of the transmitter, or replacement of the electronics board will be necessary.

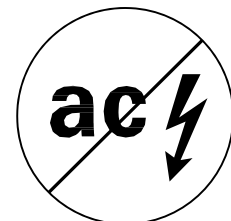

Rosemount 8732

Model 10D1419 Sensor to Rosemount 8732 Transmitter

Connect coil drive and electrode cables as shown in Figure E-7.

Figure E-7. Wiring Diagram for Fischer and Porter Sensor Model 10D1419 and Rosemount 8732

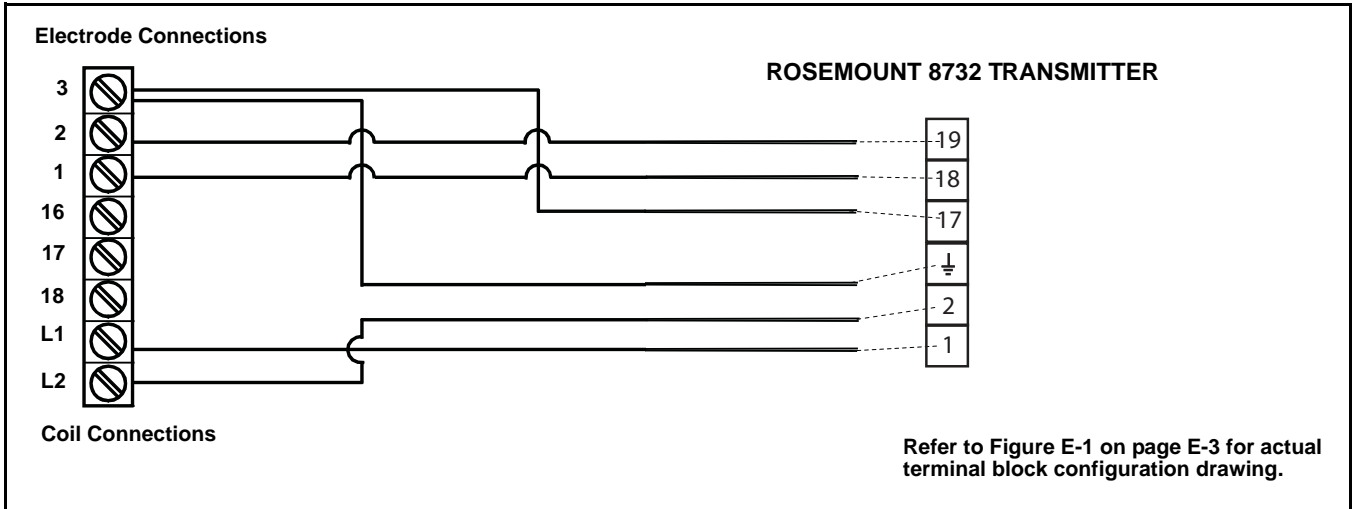

Table E-7. Fischer and Porter Model 10D1419 Sensor Wiring Connections

| Rosemount 8732 | Fischer and Porter Model 10D1419 Sensors |
|----------------|--|
| 1 | L1 |
| 2 | L2 |
| ⏏ | 3 |
| 17 | 3 |
| 18 | 1 |
| 19 | 2 |

| ⚠ CAUTION | |
|--|--|
| <p>This is a pulsed DC magnetic flowmeter. Do not connect AC power to the sensor or to terminals 1 and 2 of the transmitter, or replacement of the electronics board will be necessary.</p> | |

**Model 10D1430 Sensor
 (Remote) to
 Rosemount 8732
 Transmitter**

Connect coil drive and electrode cables as shown in Figure E-8.

Figure E-8. Wiring Diagram for Fischer and Porter Sensor Model 10D1430 (Remote) and Rosemount 8732

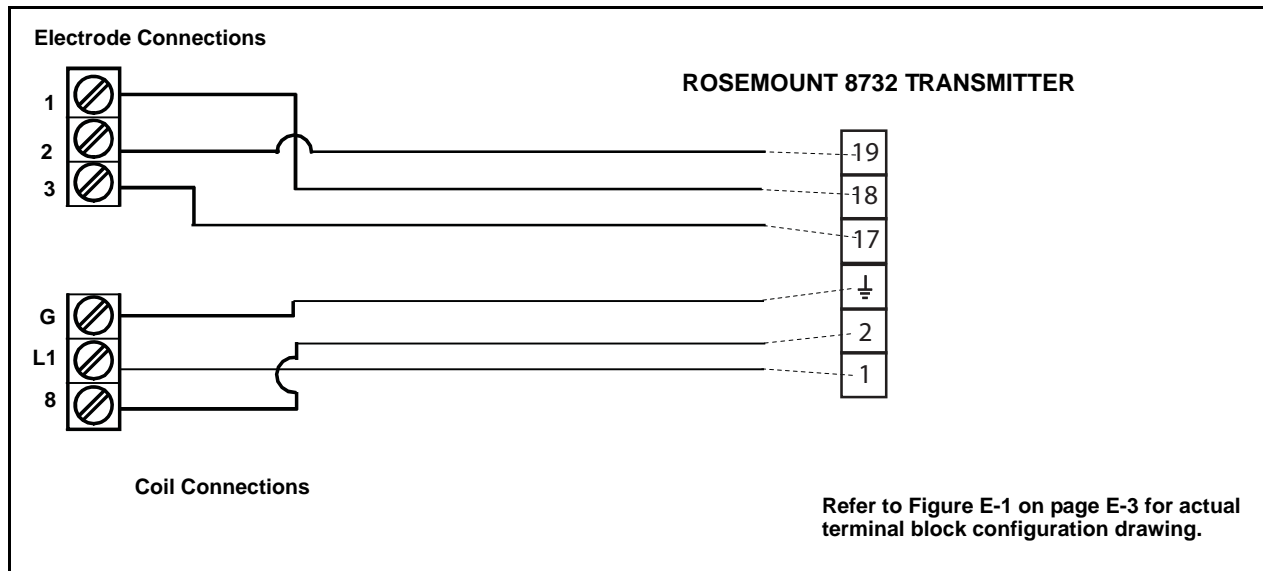

Table E-8. Fischer and Porter Model 10D1430 (Remote) Sensor Wiring Connections

| Rosemount 8732 | Fischer and Porter Model 10D1430 (Remote) Sensors |
|----------------|---|
| 1 | L1 |
| 2 | 8 |
| ⊥ | G |
| 17 | 3 |
| 18 | 1 |
| 19 | 2 |

⚠ CAUTION

This is a pulsed DC magnetic flowmeter. **Do not connect AC power to the sensor or to terminals 1 and 2 of the transmitter**, or replacement of the electronics board will be necessary.

Rosemount 8732

Model 10D1430 Sensor (Integral) to Rosemount 8732 Transmitter

Connect coil drive and electrode cables as shown in Figure E-9.

Figure E-9. Wiring Diagram for Fischer and Porter Sensor Model 10D1430 (Integral) and Rosemount 8732

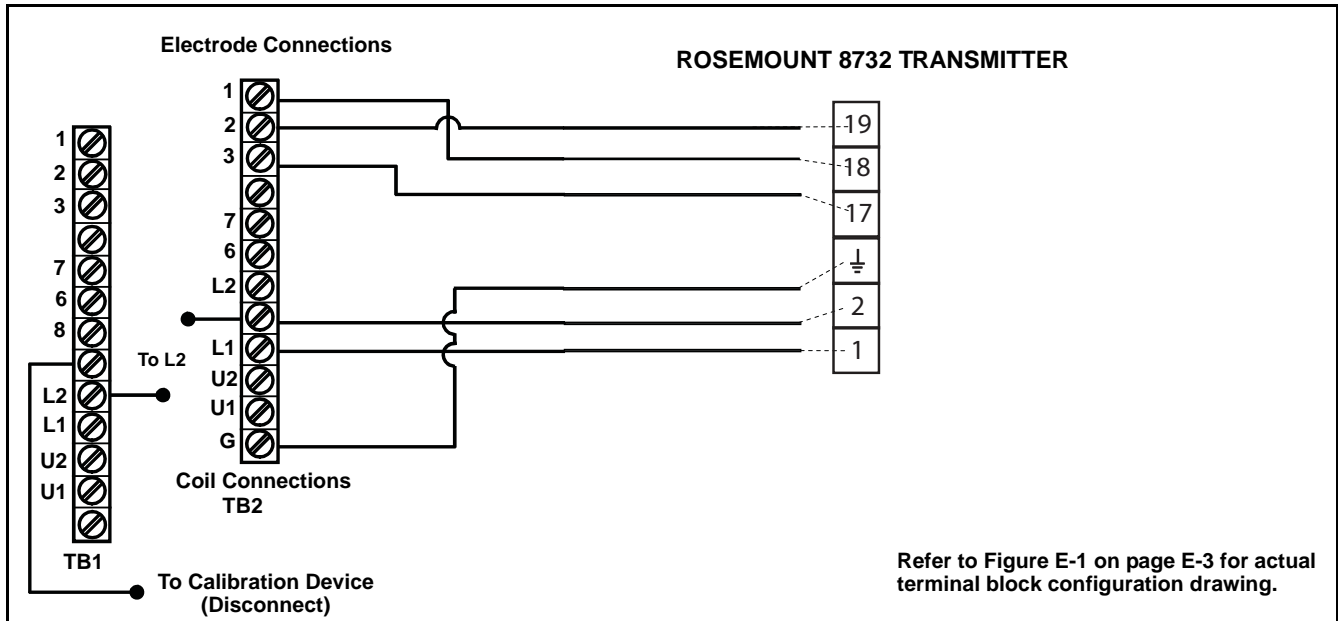

Table E-9. Fischer and Porter Model 10D1430 (Integral) Sensor Wiring Connections

| Rosemount 8732 | Fischer and Porter Model 10D1430 (Integral) Sensors |
|----------------|---|
| 1 | L1 |
| 2 | L2 |
| ⏏ | G |
| 17 | 3 |
| 18 | 1 |
| 19 | 2 |

⚠ CAUTION

This is a pulsed DC magnetic flowmeter. **Do not connect AC power to the sensor or to terminals 1 and 2 of the transmitter**, or replacement of the electronics board will be necessary.

**Model 10D1465 and
 Model 10D1475 Sensors
 (Integral) to 8732
 Transmitter**

Connect coil drive and electrode cables as shown in Figure E-10.

Figure E-10. Wiring Diagram for Fischer and Porter Sensor Model 10D1465 and Model 10D1475 (Integral) and Rosemount 8732

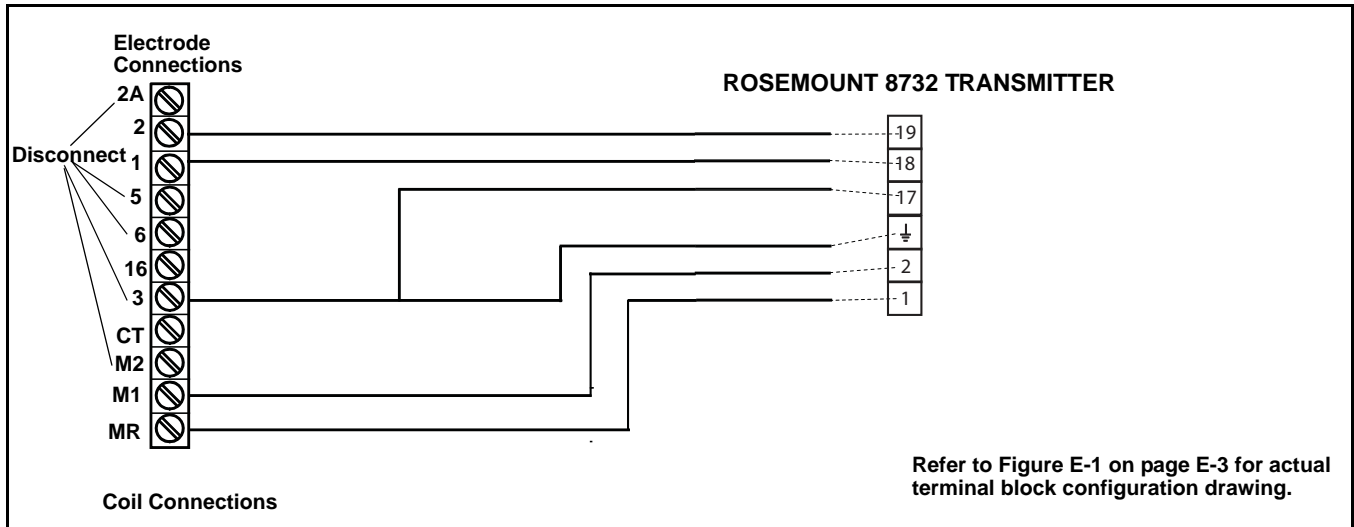

Table E-10. Fischer and Porter Model 10D1465 and 10D1475 Sensor Wiring Connections

| Rosemount 8732 | Fischer and Porter Model 10D1465 and 10D1475 Sensors |
|----------------|--|
| 1 | MR |
| 2 | M1 |
| ⏏ | 3 |
| 17 | 3 |
| 18 | 1 |
| 19 | 2 |

⚠ CAUTION

This is a pulsed DC magnetic flowmeter. **Do not connect AC power to the sensor or to terminals 1 and 2 of the transmitter**, or replacement of the electronics board will be necessary.

Fischer and Porter Sensor to Rosemount 8732 Transmitter

Connect coil drive and electrode cables as shown in Figure E-11.

Figure E-11. Generic Wiring Diagram for Fischer and Porter Sensors and Rosemount 8732

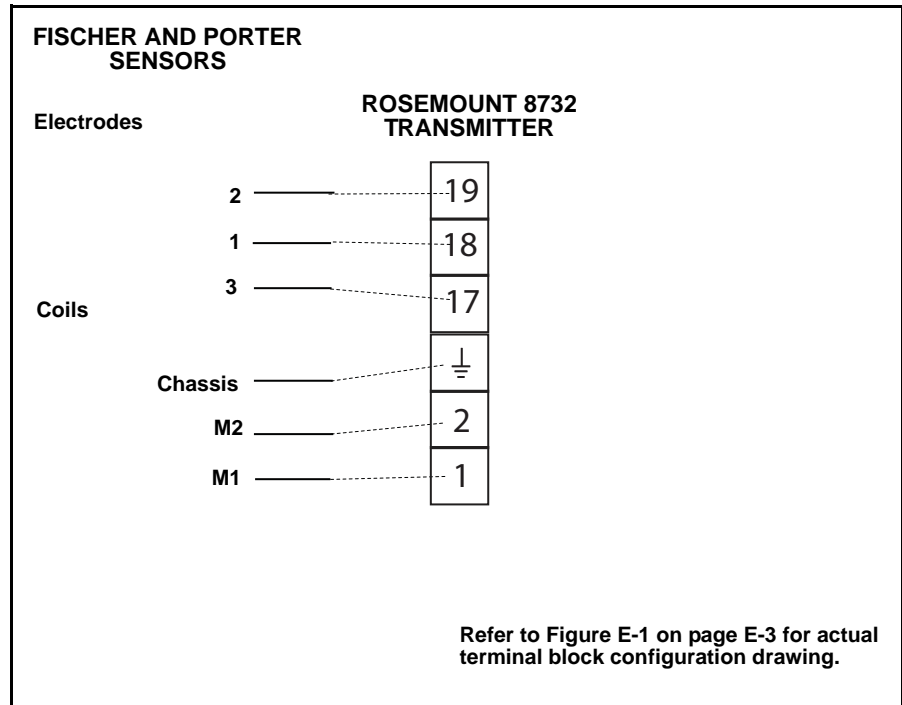

Table E-11. Fischer and Porter Generic Sensor Wiring Connections

| Rosemount 8732 | Fischer and Porter Sensors |
|----------------|----------------------------|
| 1 | M1 |
| 2 | M2 |
| ⏏ | Chassis Ground |
| 17 | 3 |
| 18 | 1 |
| 19 | 2 |

⚠ CAUTION

This is a pulsed DC magnetic flowmeter. **Do not connect AC power to the sensor or to terminals 1 and 2 of the transmitter**, or replacement of the electronics board will be necessary.

FOXBORO SENSORS

Connect coil drive and electrode cables as shown in Figure E-12.

**Series 1800 Sensor to
 Rosemount 8732
 Transmitter**

Figure E-12. Wiring Diagram for
 Foxboro Series 1800 and
 Rosemount 8732

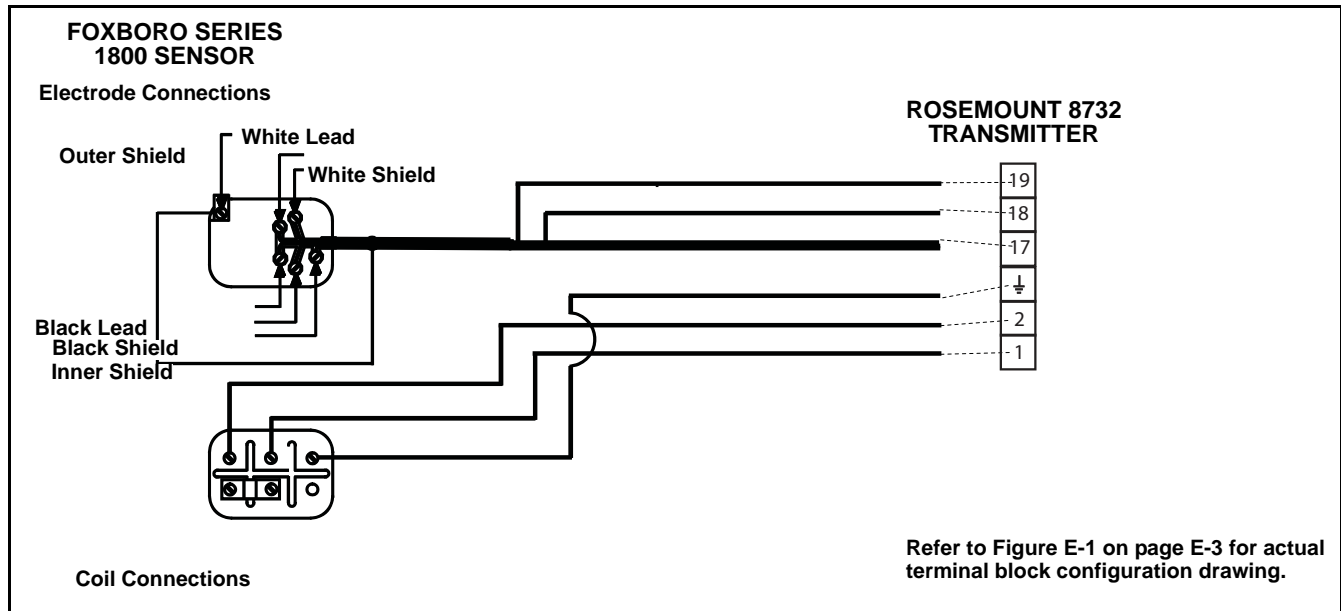

Table E-12. Foxboro Generic Sensor Wiring Connections

| Rosemount 8732 | Foxboro Series 1800 Sensors |
|----------------|-----------------------------|
| 1 | L1 |
| 2 | L2 |
| ⊥ | Chassis Ground |
| 17 | Any Shield |
| 18 | Black |
| 19 | White |

⚠ CAUTION

This is a pulsed DC magnetic flowmeter.
Do not connect AC power to the sensor or to terminals 1 and 2 of the transmitter, or replacement of the electronics board will be necessary.

Rosemount 8732

Series 1800 (Version 2) Sensor to Rosemount 8732 Transmitter

Connect coil drive and electrode cables as shown in Figure E-13.

Figure E-13. Wiring Diagram for Foxboro Series 1800 (Version 2) and Rosemount 8732

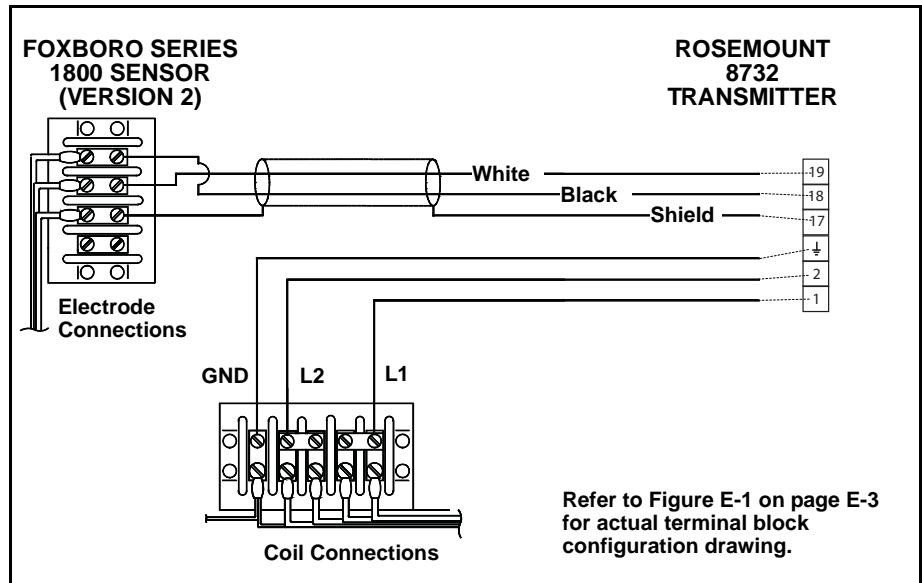

Table E-13. Foxboro Generic Sensor Wiring Connections

| Rosemount 8732 | Foxboro Series 1800 Sensors |
|----------------|-----------------------------|
| 1 | L1 |
| 2 | L2 |
| ⏏ | Chassis Ground |
| 17 | Any Shield |
| 18 | Black |
| 19 | White |

| ⚠ CAUTION | |
|--|--|
| <p>This is a pulsed DC magnetic flowmeter. Do not connect AC power to the sensor or to terminals 1 and 2 of the transmitter, or replacement of the electronics board will be necessary.</p> | |

**Series 2800 Sensor to
 8732 Transmitter**

Connect coil drive and electrode cables as shown in Figure E-14.

Figure E-14. Wiring Diagram for
 Foxboro Series 2800 and
 Rosemount 8732

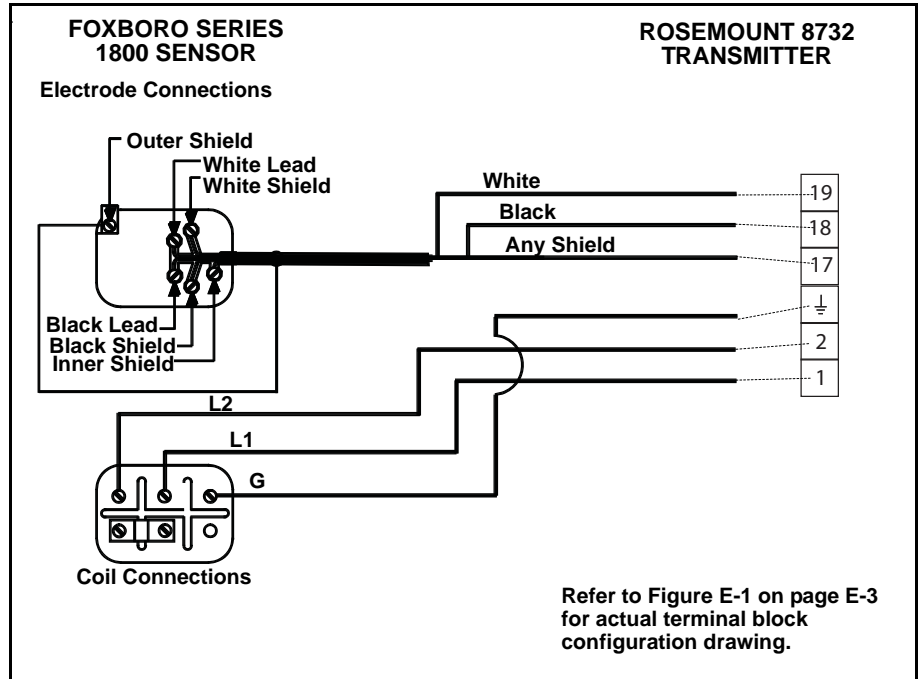

Table E-14. Foxboro Series 2800 Sensor Wiring Connections

| Rosemount 8732 | Foxboro Series 2800 Sensors |
|----------------|-----------------------------|
| 1 | L1 |
| 2 | L2 |
| 1 | Chassis Ground |
| 17 | Any Shield |
| 18 | Black |
| 19 | White |

CAUTION

This is a pulsed DC magnetic flowmeter. **Do not connect AC power to the sensor or to terminals 1 and 2 of the transmitter**, or replacement of the electronics board will be necessary.

Foxboro Sensor to 8732 Transmitter

Connect coil drive and electrode cables as shown in Figure E-15.

Figure E-15. Generic Wiring Diagram for Foxboro Sensors and Rosemount 8732

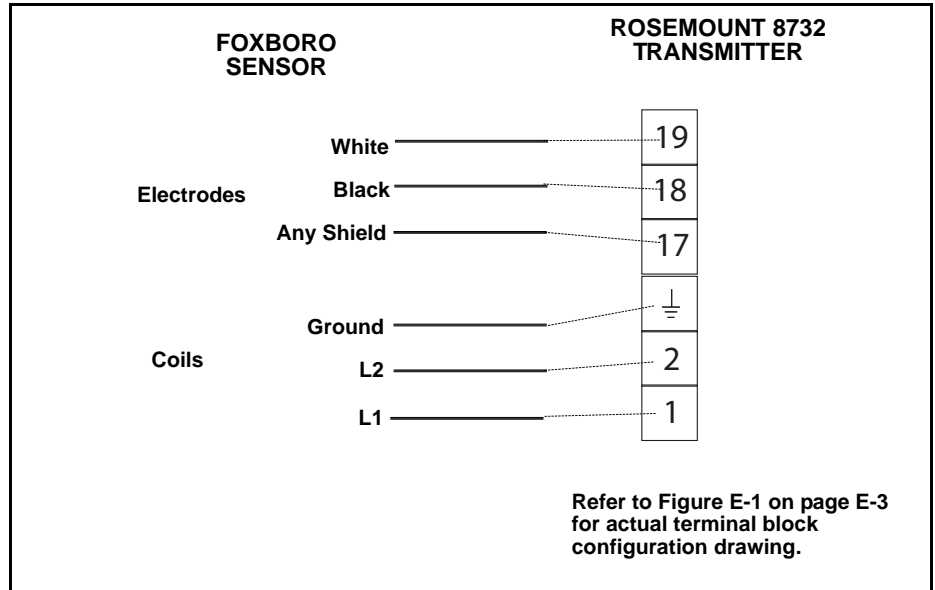

Table E-15. Foxboro Sensor Wiring Connections

| Rosemount 8732 | Foxboro Sensors |
|----------------|-----------------|
| 1 | L1 |
| 2 | L2 |
| \perp | Chassis Ground |
| 17 | Any Shield |
| 18 | Black |
| 19 | White |

⚠ CAUTION

This is a pulsed DC magnetic flowmeter. **Do not connect AC power to the sensor or to terminals 1 and 2 of the transmitter**, or replacement of the electronics board will be necessary.

KENT VERIFLUX VTC SENSOR

Connect coil drive and electrode cables as shown in Figure E-16.

Veriflux VTC Sensor to 8732 Transmitter

Figure E-16. Wiring Diagram for Kent Veriflux VTC Sensor and Rosemount 8732

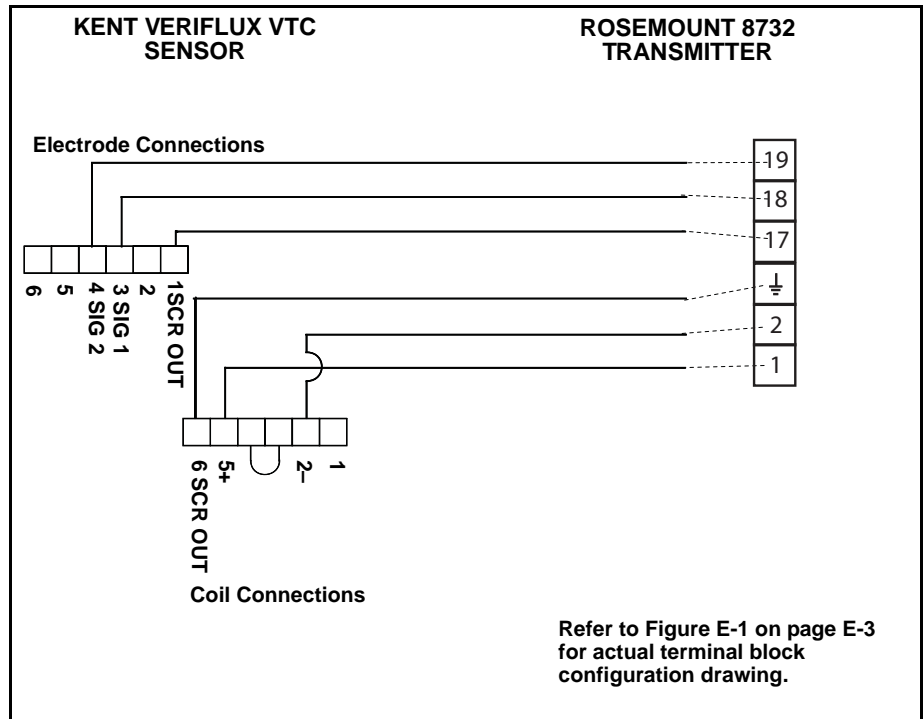

Table E-16. Kent Veriflux VTC Sensor Wiring Connections

| Rosemount 8732 | Kent Veriflux VTC Sensors |
|----------------|---------------------------|
| 1 | 2 |
| 2 | 1 |
| ⊥ | SCR OUT |
| 17 | SCR OUT |
| 18 | SIG1 |
| 19 | SIG2 |

⚠ CAUTION

This is a pulsed DC magnetic flowmeter. **Do not connect AC power to the sensor or to terminals 1 and 2 of the transmitter**, or replacement of the electronics board will be necessary.

Rosemount 8732

KENT SENSORS

Connect coil drive and electrode cables as shown in Figure E-17.

Kent Sensor to Rosemount 8732 Transmitter

Figure E-17. Generic Wiring Diagram for Kent Sensors and Rosemount 8732

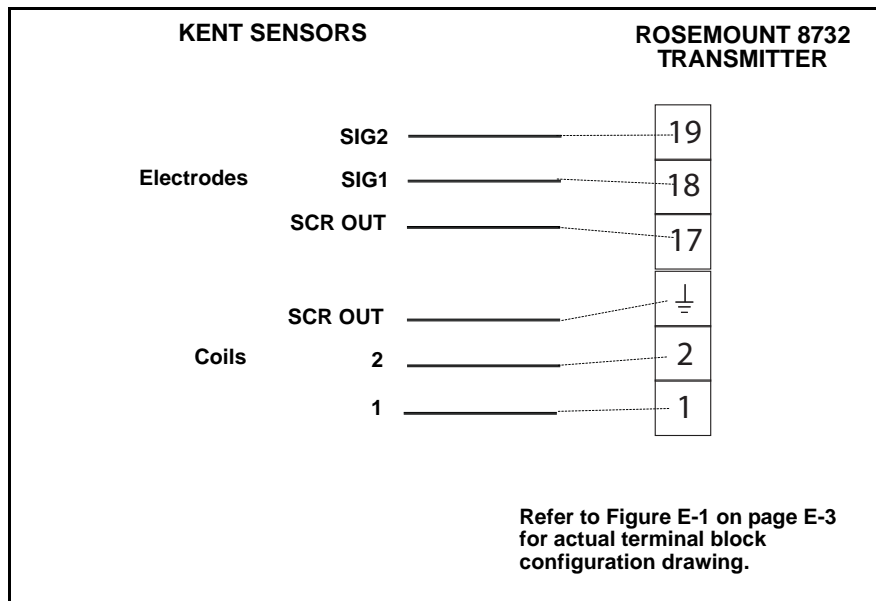

Table E-17. Kent Sensor Wiring Connections

| Rosemount 8732 | Kent Sensors |
|----------------|--------------|
| 1 | 1 |
| 2 | 2 |
| ⏏ | SCR OUT |
| 17 | SCR OUT |
| 18 | SIG1 |
| 19 | SIG2 |

⚠ CAUTION

This is a pulsed DC magnetic flowmeter. **Do not connect AC power to the sensor or to terminals 1 and 2 of the transmitter**, or replacement of the electronics board will be necessary.

KROHNE SENSORS

Connect coil drive and electrode cables as shown in Figure E-18.

**Krohne Sensor to
 Rosemount 8732
 Transmitter**

Figure E-18. Generic Wiring Diagram for Krohne Sensors and Rosemount 8732

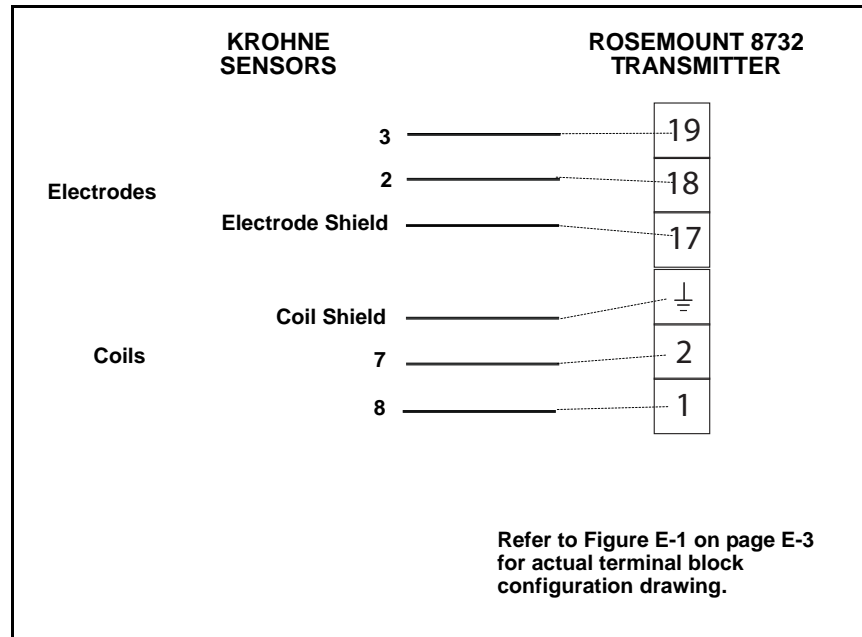
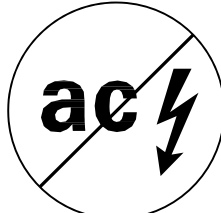

Table E-18. Krohne Sensor Wiring Connections

| Rosemount 8732 | Krohne Sensors |
|----------------|------------------|
| 1 | 8 |
| 2 | 7 |
| ⏏ | Coil Shield |
| 17 | Electrode Shield |
| 18 | 2 |
| 19 | 3 |

⚠ CAUTION

| | |
|--|---|
| <p>This is a pulsed DC magnetic flowmeter. Do not connect AC power to the sensor or to terminals 1 and 2 of the transmitter, or replacement of the electronics board will be necessary.</p> |  |
|--|---|

Rosemount 8732

TAYLOR SENSORS

Connect coil drive and electrode cables as shown in Figure E-19.

Series 1100 Sensor to Rosemount 8732 Transmitter

Figure E-19. Wiring Diagram for Taylor Series 1100 Sensors and Rosemount 8732

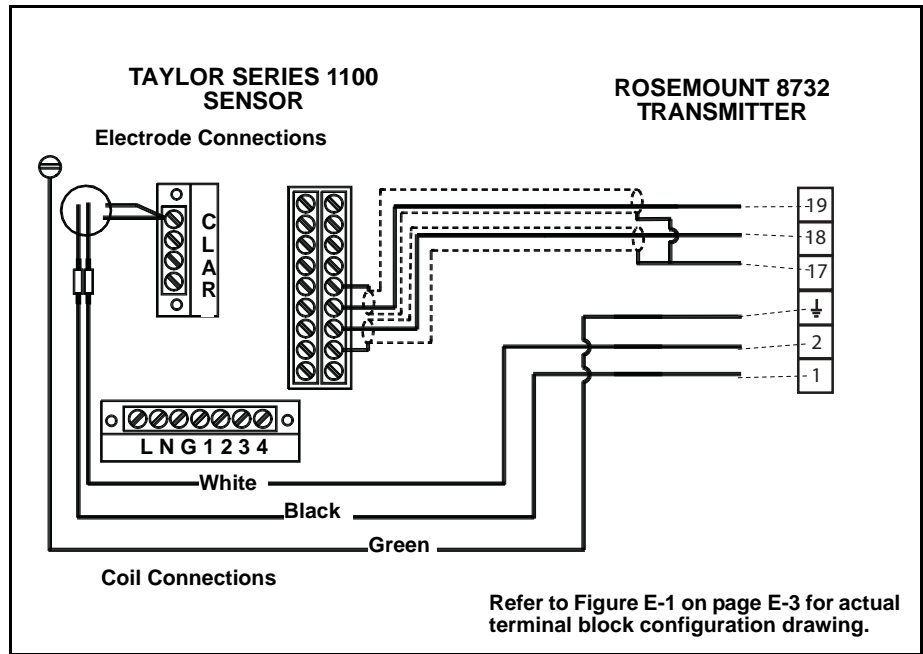
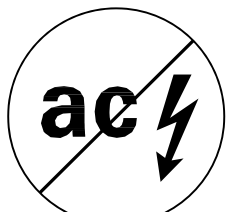

Table E-19. Taylor Series 1100 Sensor Wiring Connections

| Rosemount 8732 | Taylor Series 1100 Sensors |
|----------------|----------------------------|
| 1 | Black |
| 2 | White |
| ⏏ | Green |
| 17 | S1 and S2 |
| 18 | E1 |
| 19 | E2 |

| ⚠ CAUTION | |
|--|---|
| <p>This is a pulsed DC magnetic flowmeter. Do not connect AC power to the sensor or to terminals 1 and 2 of the transmitter, or replacement of the electronics board will be necessary.</p> |  |

**Taylor Sensor to
 Rosemount 8732
 Transmitter**

Connect coil drive and electrode cables as shown in Figure E-20.

Figure E-20. Generic Wiring Diagram for Taylor Sensors and Rosemount 8732

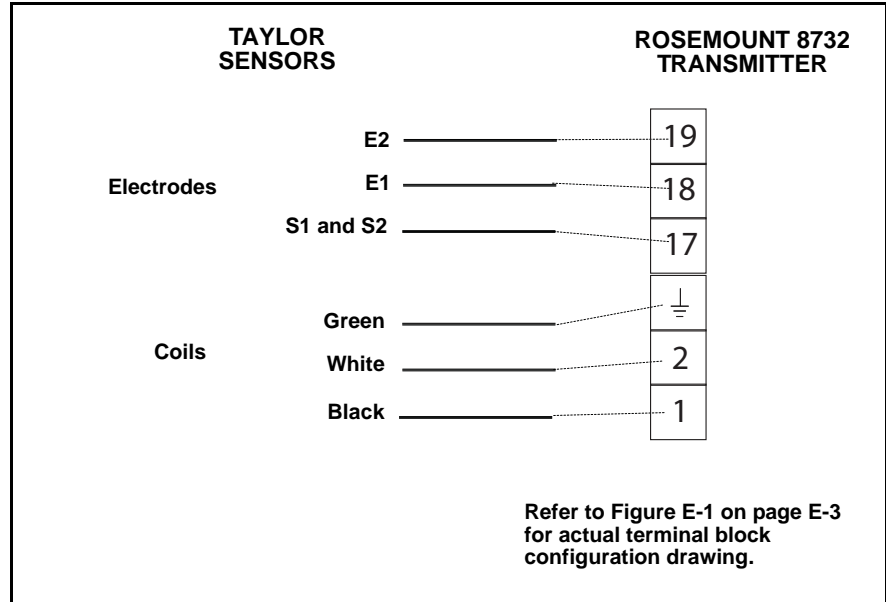

Table E-20. Taylor Sensor Wiring Connections

| Rosemount 8732 | Taylor Sensors |
|----------------|----------------|
| 1 | Black |
| 2 | White |
| 3 | Green |
| 17 | S1 and S2 |
| 18 | E1 |
| 19 | E2 |

⚠ CAUTION

This is a pulsed DCDC magnetic flowmeter. **Do not connect AC power to the sensor or to terminals 1 and 2 of the transmitter**, or replacement of the electronics board will be necessary.

Rosemount 8732

YAMATAKE HONEYWELL SENSORS

Yamatake Honeywell Sensor to Rosemount 8732 Transmitter

Connect coil drive and electrode cables as shown in Figure E-21.

Figure E-21. Generic Wiring Diagram for Yamatake Honeywell Sensors and Rosemount 8732

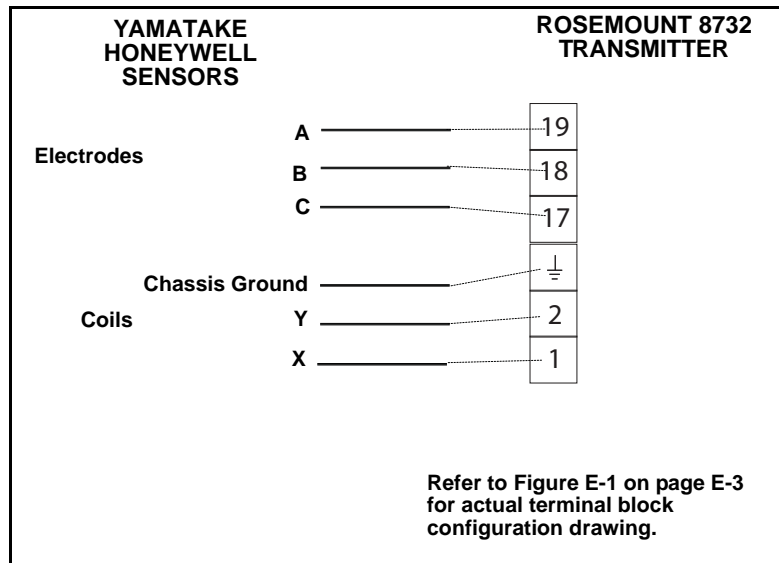
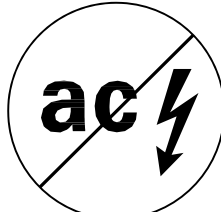

Table E-21. Yamatake Honeywell Sensor Wiring Connections

| Rosemount 8732 | Yamatake Honeywell Sensors |
|----------------|----------------------------|
| 1 | X |
| 2 | Y |
| ⏏ | Chassis Ground |
| 17 | C |
| 18 | B |
| 19 | A |

⚠ CAUTION

| | |
|--|---|
| <p>This is a pulsed DC magnetic flowmeter. Do not connect AC power to the sensor or to terminals 1 and 2 of the transmitter, or replacement of the electronics board will be necessary.</p> |  |
|--|---|

YOKOGAWA SENSORS

Connect coil drive and electrode cables as shown in Figure E-22.

**Yokogawa Sensor to
 Rosemount 8732
 Transmitter**

Figure E-22. Generic Wiring Diagram for Yokogawa Sensors and Rosemount 8732

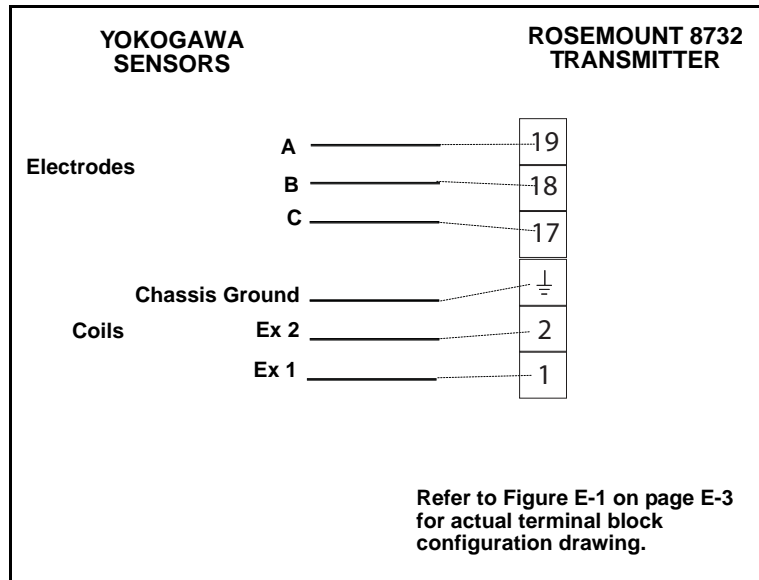

Table E-22. Yokogawa Sensor Wiring Connections

| Rosemount 8732 | Yokogawa Sensors |
|----------------|------------------|
| 1 | EX1 |
| 2 | EX2 |
| ⏏ | Chassis Ground |
| 17 | C |
| 18 | B |
| 19 | A |

⚠ CAUTION

This is a pulsed DC magnetic flowmeter. **Do not connect AC power to the sensor or to terminals 1 and 2 of the transmitter**, or replacement of the electronics board will be necessary.

Rosemount 8732

GENERIC MANUFACTURER SENSORS

Generic Manufacturer Sensor to Rosemount 8732 Transmitter

Identify the Terminals

First check the sensor manufacturer's manual to identify the appropriate terminals. Otherwise, perform the following procedure.

Identify coil and electrode terminals

1. Select a terminal and touch an ohmmeter probe to it.
2. Touch the second probe to each of the other terminals and record the results for each terminal.
3. Repeat the process and record the results for every terminal.

Coil terminals will have a resistance of approximately 3-300 ohms.

Electrode terminals will have an open circuit.

Identify a chassis ground

1. Touch one probe of an ohmmeter to the sensor chassis.
2. Touch the other probe to the each sensor terminal and the record the results for each terminal.

The chassis ground will have a resistance value of one ohm or less.

Wiring Connections

Connect the electrode terminals to Rosemount 8732 terminals 18 and 19. The electrode shield should be connected to terminal 17.

Connect the coil terminals to Rosemount 8732 terminals 1, 2, and $\frac{1}{2}$.

If the Rosemount 8732 Transmitter indicates a reverse flow condition, switch the coil wires connected to terminals 1 and 2.

CAUTION

This is a pulsed DC magnetic flowmeter.
Do not connect AC power to the sensor or to terminals 1 and 2 of the transmitter, or replacement of the electronics board will be necessary.

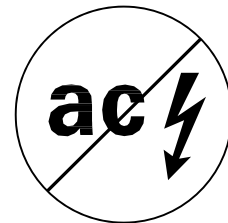

Index

A

- Analog Output
 - Range 3-9
 - Zero 3-9
- Analog Output Adjustment . . . A-4
- Analog Output Test A-6
- Analog Power 2-6
- Applications/Configurations . . . 2-4
- Auto Zero D-2
- Auxiliary Output 2-15, A-5

B

- Basic Setup 3-5, 3-6
- Bolts
 - Flanged 5-7

C

- Cables
 - Conduit 2-8, 2-19
- Conduit Connections
 - Installation 2-8, 2-19
- Conduit Ports and Connections
 - Wiring 2-5
- Configurations/Applications . . . 2-4

D

- Dedicated Conduit 2-18
- Device Software Functions
 - Basic Setup 3-5, 3-6
- Diagnostic Messages 6-3
 - LOI 3-4
- Digital Signal Processing D-1
- Direction 5-5
- Display Lock 3-3
- Downstream/Upstream Piping . . 5-4

E

- Electrical
 - Considerations 2-8
- Electrical Considerations 2-8
- Environmental Considerations . . 2-4

F

- Failure Alarm Mode 2-5
- Fast Keys 3-10
- Flange Bolts 5-7
- Flanges
 - Class 150 5-11
 - Class 300 5-11
- Flow Direction 5-5, 5-6

Flow Rate

- Units 3-7, 3-8

Flowtube

- Orientation 5-4
- Test 6-10

Flowtubes

- Brooks Model 5000 E-6
- Endress and Hauser Models E-5
- Fischer and Porter Model 10D1418 E-9
- Foxboro Series 1800 E-15
- Generic Flowtube E-26
- Kent Flowtubes E-20
- Kent Veriflux VTC E-19
- Krohne Flowtubes E-21
- Rosemount Model
 - 8705/8707/8711 E-3
- Taylor Series 1100 E-22
- Yamatake Honeywell Flowtubes E-24
- Yokogawa Flowtubes E-25

G

- Gaskets 5-7
 - Installation
 - Wafer Flowtube 5-10
- Ground Connection
 - Internal 5-13
 - Protective 5-13
- Grounding 5-12
 - Grounding Electrodes 5-13
 - Grounding Rings 5-13
 - Lining Protectors 5-13
 - Process Grounding 5-12

I

Installation

- Auxiliary Output 2-15
- Category 2-10
- Conduit Connections 2-8, 2-19
- Connect 4-20 mA Loop External
 - Power Source 2-11
- Considerations 2-10
- Diagram
 - Cable Preparation 2-20
- Environmental Considerations 2-4
- Mechanical Considerations 2-2
- Mounting 2-4
- Options 2-10
- Positive Zero Return 2-16
- Procedures 2-4
- Process Leak
 - Containment 5-17
- Relief Valves 5-16
- Safety Messages 2-1, 5-1
- Wafer Flowtube 5-10, 5-12
 - Alignment and Bolting 5-10
 - Flange Bolts 5-11
 - Gaskets 5-10
- Installation Category 2-10
- Internal
 - Ground Connection 5-13

L

- Line Power Fuses A-9
- Line Size 3-9
- Lining Protectors
 - Grounding 5-13
- Load Resistor Requirements . . . 2-12
- Local Operator Interface (LOI)
 - Diagnostic Messages 3-4
 - Examples 3-2
- Lock LOI 3-3
- Lower Range Value (LRV) 3-9

M

- Maximum Power Requirement 2-12
- Mechanical Considerations 2-2, 2-8
- Messages
 - Safety 1-2
- Mounting 2-4

N

- North American Response Center 1-2

Rosemount 8732

O

- Options 2-4
- Orientation
 - Flowtube 5-4
- Output
 - Power 2-6
- Output Signals A-4
- Output Testing A-6
- Overcurrent Protection 2-10
- Overrange Capability A-6

P

- Piping 5-4
- Positive Zero Return 2-16
- Power
 - Source 2-11
- Power Supply Load Limitations 2-11, A-3
- Process Grounding 5-12
- Process Leak
 - Containment 5-17
- Process Variables 3-5
- Protection
 - Overcurrent 2-10
- Protective
 - Ground Connection 5-13
- Pulse Duration Requirements 2-12
- Pulse Output Test A-6
- PZR 2-16

R

- Relief Valves 5-16

S

- Safety Messages 1-2
- Scalable Frequency Adjustment A-4
- Security 2-6
- Signal Processing D-2
- Specifications and Reference Data
 - Functional Specifications
 - Output Signals A-4
 - Output Testing A-6
 - Overrange Capability . A-6
 - Physical Specifications
 - Line Power Fuses . . . A-9
- Supply Voltage
 - Requirements 2-12
- Switches 2-5
 - Changing Settings 2-6
 - Closure Requirements . . 2-12
 - Failure Alarm Mode 2-5

T

- Tag 3-6

Transmitter Output Instability

- Auto Zero D-2
- Procedures D-2
- Signal Processing D-2
- Transmitter Security 2-6
- Transporting System 5-3
- Troubleshooting
 - Advanced (Transmitter) . . 6-7
 - Installed Flowtube Tests . . 6-9
 - Process Noise 6-9
 - Uninstalled Flowtube Tests 6-11
 - Wiring Errors 6-9

U

- Upper Range Value (URV) . . . 3-9
- Upstream/Downstream Piping 5-4
 - Accuracy
 - Ensuring 5-4

W

- Wiring
 - Conduit Ports and Connections 2-5
 - Dedicated Conduit 2-18
 - Installation Category . . . 2-10
- Wiring Diagrams
 - Brooks Model 5000 E-6
 - Endress and Hauser Models E-5
 - Fisher and Porter Model 10D1418 E-9
 - Foxboro Series 1800 . . . E-15
 - Generic Flowtube E-26
 - Kent Flowtubes E-20
 - Kent Veriflux VTC E-19
 - Krohne Flowtubes E-21
 - Rosemount Model
 - 8705/8707/8711 . . E-3
 - Taylor Series 1100 E-22
 - Yamatake Honeywell Flowtubes E-24
 - Yokogawa Flowtubes . . E-25

*The Emerson logo is a trade mark and service mark of Emerson Electric Co.
Rosemount and the Rosemount logotype are registered trademarks of Rosemount Inc.
PlantWeb is a registered trademark of one of the Emerson Process Management group of companies.
All other marks are the property of their respective owners.*

Standard Terms and Conditions of Sale DADAn be found at www.rosemount.com/terms_of_sale

Emerson Process Management

Rosemount Measurement
8200 Market Boulevard
Chanhassen, MN 55317 USA
T (U.S.) 1-800-999-9307
T (International) (952) 906-8888
F (952) 906-8889
www.rosemount.com

Emerson Process Management
Blegistrasse 23
P.O. Box 1046
CH 6341 Baar
Switzerland
T +41 (0) 41 768 6111
F +41 (0) 41 768 6300

**Emerson Process Management Asia
Pacific Private Limited**
1 Pandan Crescent
Singapore 128461
T (65) 6777 8211
F (65) 6777 0947
Enquiries@AP.EmersonProcess.com

Emerson FZE
P.O. Box 17033
Jebel Ali Free Zone
Dubai UAE
T +971 4 883 5235
F +971 4 883 5312