

Rosemount™ 5708 3D Solids Scanner



Contents

Section 2: Contents

Section 1: Introduction

1.1 Product recycling/disposal	1
1.2 Storage and transport	1

Section 2: Overview

2.1 Theory of operation	3
2.2 Applications	3
2.2.1 Wide application range	3
2.2.2 Advantages	3
2.2.3 Models	4
2.3 Components of the Rosemount 5708	4

Section 3: Mechanical Installation

3.1 Installation procedure	7
3.2 Mounting considerations	7
3.2.1 Location and positioning guidelines	8
3.2.2 Rosemount 5708 orientation	8
3.2.3 Mounting location	12
3.2.4 Site preparations	13
3.2.5 Site and installation information	14
3.3 Physical mounting	17

Section 4: Electrical Installation

4.1 Grounding	23
4.2 Cable selection	23
4.3 Hazardous areas	23
4.4 Wiring	24
4.5 Different connection methods	29
4.5.1 4-20 mA connection	29
4.5.2 RS-485 communication	30
4.5.3 Communication using the Rosemount LinkPro	31
4.5.4 TCP/IP communication	31

Section 5: Configuration - Rosemount 5708L

5.1 On-board configuration	33
5.2 Setting the polling address.....	34
5.3 Configuring the Rosemount 5708L.....	35
5.3.1 Basic Settings.....	35
5.3.2 Advanced Settings	36
5.3.3 False Echo Mapping	38

Section 6: Configuration - Rosemount 5708V and 5708S

6.1 On-board configuration	39
6.2 Setting the polling address.....	40

Section 7: Operation

7.1 Rosemount 3D Vision/3D MultiVision overview	41
7.1.1 Server-client architecture	42
7.1.2 Multi-client.....	42
7.1.3 System requirements.....	44
7.1.4 Network considerations.....	44
7.2 Installing the Rosemount 3D Vision software	45
7.2.1 Required information.....	45
7.2.2 Installation	45
7.2.3 Starting Rosemount 3D Vision Server and Client.....	51
7.3 First-time running	54
7.3.1 Creating a new project.....	54
7.3.2 Vessel configuration.....	58
7.3.3 Advanced parameters	62
7.3.4 Echo curve analysis.....	62
7.3.5 False echo mapping	62
7.3.6 Vessel properties configuration	62
7.4 Software navigation.....	66
7.4.1 Project overview	66
7.4.2 Main screen	66
7.4.3 Main menu bar	67
7.4.4 Project toolbar.....	83
7.4.5 Vessel selection behavior	85
7.4.6 Vessel pane	89

7.5	Advanced tools	91
7.5.1	Communication methods	91
7.5.2	Advanced parameters	96
7.5.3	Device current simulation settings	101
7.5.4	Device output current	102
7.5.5	Device output settings	103
7.5.6	Echo Curve Analysis	109
7.5.7	False Echo Mapping	112
7.5.8	Device activations	114
7.5.9	Model upgrade	116
7.5.10	Reports Wizard	116
7.5.11	Event log	124
7.5.12	User management	126
7.5.13	Material configuration	127
7.5.14	3D visualization	128
7.5.15	Multi-server connection	130
7.5.16	Upgrading to Rosemount 3DMultiVision	132
7.5.17	Center of Gravity	133
7.5.18	Level by Section Output	134

Section 8: Configuration - Rosemount 5708 in a System

8.1	System overview and components	137
8.2	Rosemount System Controller advantages	139
8.3	System requirements	140
8.4	Mounting the Rosemount System Controller	141
8.5	Advanced commissioning steps	142

Section 9: Service and Troubleshooting

9.1	Maintenance	145
9.1.1	Preventive maintenance procedure	145
9.1.2	Preventive maintenance frequency	145
9.2	Log views	146
9.3	Vessel Data Collection (VDC)	147
9.4	Removing the Rosemount 5708 head	150
9.5	Changing the Rosemount 5708 antenna	151
9.6	Diagnostic messages	152
9.7	Parameters and alerts	152

9.7.1 Alert types	152
9.7.2 Selecting properties to be displayed.....	153
9.7.3 Setting alert threshold.....	153
9.7.4 General tab.....	154
9.8 Service support.....	155
9.8.1 Packaging and shipping of return products/parts	156

Appendix A: Specifications and Reference Data

A.1 Product Certifications	157
A.2 Ordering Information, Specifications, and Drawings	157

Appendix B: Connection via Modbus RTU

B.1 Initial settings	159
B.2 Registers	160
B.3 Communication examples	160

Appendix C: Connection via RS-485

C.1 Physical layer.....	161
C.2 Parameters and units.....	161

Appendix D: Rosemount LinkPro Operating Instructions

D.1 About this document.....	165
D.1.1 Intended audience	165
D.1.2 Safety	165
D.2 Rosemount LinkPro overview.....	166
D.2.1 Components	166
D.2.2 Area of application	167
D.2.3 Technical concept.....	167
D.2.4 Operation	167
D.2.5 GPRS modem.....	167
D.3 Technical specifications	168
D.3.1 Modem specifications	168
D.3.2	Rosemount LinkPro specifications169
D.4 Mounting.....	170
D.4.1 Position.....	170
D.4.2 Moisture	170
D.4.3 Wall mounting.....	170
D.5 Rosemount LinkPro Setup	172

D.5.1	Connection	172
D.5.2	Wiring plan	173
D.5.3	Modem connection	174
D.6	Modem wizard	175
D.6.1	Getting started	175
D.6.2	Test performance	175
D.6.3	Configure APN details	177
D.6.4	Configure mode of operation	177
D.7	Troubleshooting	178

Appendix E: Accessories

E.0.1	Cable extender	181
E.0.2	Neck Extension	182
E.0.3	Package components	183
E.1	Neck extension	184
E.1.1	Required equipment	184
E.1.2	Assembling the neck extension	184
E.2	Angle adapter	186
E.2.1	Parts of the adapter	186
E.2.2	Assembling the angle adapter	187

Rosemount™ 5708 3D Solids Scanner

NOTICE

Read this manual before working with the product. For personal and system safety, and for optimum product performance, make sure you thoroughly understand the contents before installing, using, or maintaining this product.

Within the United States, Emerson has two toll-free assistance numbers.

Customer Central: 1-800-999-9307 (7:00 a.m. to 7:00 p.m. CST)

Technical support, quoting, and order-related questions.

North-American Response Center:

Equipment service needs.

1-800-654-7768 (24 hours—includes Canada)

For equipment service or support needs outside the United States, contact your local Emerson™ representative.

⚠ WARNING

Failure to follow safe installation and service guidelines could result in death or serious injury.

- Make sure the Rosemount 5708 is installed by qualified personnel and in accordance with applicable code of practice.
- Use the equipment only as specified in this manual. Failure to do so may impair the protection provided by the equipment.
- Inappropriate or incorrect use of the product may result in hazards and application-specific malfunctioning, such as vessels overfill or damage to system components, through incorrect mounting or adjustments.
- Do not perform any services other than those contained in this manual unless you are qualified.
- Any substitution of non-authorized parts or repair, other than exchanging the complete transmitter head or antenna assembly, may jeopardize safety and is prohibited.
- Unauthorized changes to the product are strictly prohibited as they may unintentionally and unpredictably alter performance and jeopardize safety. Unauthorized changes that interfere with the integrity of the welds or mounting plates, such as making additional perforations, compromise product integrity and safety. Equipment ratings and certifications are no longer valid on any products that have been damaged or modified without the prior written permission of Emerson. Any continued use of product that has been damaged or modified without prior written authorization is at the customer's sole risk and expense.

Explosions could result in death or serious injury.

- Verify that the operating environment of the transmitter is consistent with the appropriate hazardous locations specifications.
- To prevent ignition of flammable or combustible atmospheres, disconnect power before servicing.

Electrical shock can result in death or serious injury.

- Avoid contact with the leads and terminals. High voltage that may be present on leads can cause electrical shock.
- Make sure the main power to the Rosemount 5708 is off and the lines to any other external power source are disconnected or not powered while wiring the transmitter.

⚠ CAUTION

The products described in this document are NOT designed for nuclear-qualified applications.

Using non-nuclear qualified products in applications that require nuclear-qualified hardware or products may cause inaccurate readings.

For information on Rosemount nuclear-qualified products, contact your local Emerson Sales Representative.

This product is designed to meet FCC and R&TTE requirements for a non-intentional radiator. It does not require any licensing whatsoever and has no tank restrictions associated with telecommunications issues.

This product complies with part 15 of the FCC rules. Operation is subject to the following two conditions: (1) This product may not cause harmful interference, and (2) this product must accept any interference received, including interference that may cause undesired operation.

Section 1 Introduction

This reference manual provides detailed product related information, installation, setup and operation instructions for the Rosemount™ 5708. The manual is designed for trained personnel. Read it entirely and carefully before unpacking and installing the products.

WARNING

Indication of a potentially dangerous situation, which could result in serious injury to persons and/or damage to the Rosemount 5708.



Procedures and instructions in this manual may require special precautions to ensure the safety of the personnel performing the operations. Information that raises potential safety issues is indicated by a warning symbol. Refer to the safety messages listed at the beginning of each section before performing an operation preceded by this symbol.



An indication of special instructions relevant to installations in hazardous locations.

1.1 Product recycling/disposal

Recycling of equipment and packaging should be taken into consideration and disposed of in accordance with local and national legislation/regulations.

1.2 Storage and transport

The Rosemount 5708 is protected by special packaging during transport, and is guaranteed to handle normal loads during transport.

Section 2 Overview

Theory of operation	page 3
Applications	page 3
Components of the Rosemount 5708	page 4

2.1 Theory of operation

Rosemount™ 5708 delivers accurate volumetric measurement of bulk solids and powders – regardless of material type, product characteristics, storage silo type, size, bin or container, and harshness of the storage environment. The product incorporates unique dust-penetrating technology to achieve an unrivaled degree of process measurement and inventory control.

The Rosemount 5708 include an array of three antennas that generate low frequency acoustic signals and receive echo signals from the contents of the silo, bin, or other container type. Using these antennas, the unit measures not only the time/distance of each echoed signal but also its direction and generate a coordinate of the echo inside the vessel.

The built-in digital signal processor digitally samples and analyses the echoed signals and produces accurate measurements of the level and volume of the stored contents, and can generate a 3D visualization position and form of the material within the container for displaying on remote computer screens.

2.2 Applications

2.2.1 Wide application range

The Rosemount 5708 can measure practically any kind of solid material, stored in a variety of containers, including large open bins, bulk solid storage rooms, stockpiles and warehouses, mapping loads that randomly form over time inside silos, and many other challenging applications that were not possible until now. The Rosemount 5708 can measure ranges of up to 230 ft. (70 m) and generate 3D visualization of the material surface when installed according to the guidelines within this manual.

2.2.2 Advantages

- Non-contacting measuring principle, easy to service and maintain
- Measures minimum and maximum levels
- Suitable for measuring all solid materials (including ones with low dielectric constants)
- Operates in dusty and moist environments
- Profiles of adhesions of materials to vessel walls
- Self-cleaning antenna
- 3D mapping visualization tool that can be used for assistance with choosing a filling location for even distribution of material (in vessels with multiple filling points)
- Includes three transmitters and three receivers integrally assembled into a single unit

2.2.3 Models

The Rosemount 5708 consists of three sub-models: Rosemount 5708L, 5708V, and 5708S. All meet safety approvals outlined by ATEX, FM and others.

Rosemount 5708L

The model determines the average level of the stored contents and average distance from the Rosemount 5708 to the surface of the material. The Rosemount 5708L is suitable for narrow silos.

Rosemount 5708V

The Rosemount 5708V models yield highly accurate readings of level and volume. It is appropriate for vessels of up to 40 ft.ft. (12 m) in diameter and at least twice as high, open bins and stockpiles. It presents the minimum and maximum Level/Distance measurements along with the calculated average and volume.

Rosemount 5708S

The Rosemount 5708S models have the capability of generating a 3D visualization of the stored contents on a remote computer and to be mounted with additional devices in the same vessel. These features are highly useful for mapping build-up loads that form randomly over time and other irregularities and for monitoring inventory in large vessels.

2.3 Components of the Rosemount 5708

The Rosemount 5708 is divided into two parts:

- Antennas
- Head

Figure 2-1. Components of the Rosemount 5708

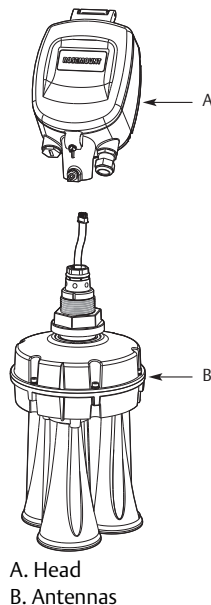

The antennas contain:

- Three antennas, sealed with a customized tin foil
- 2.04-in. (52 mm) thread to fasten the Rosemount 5708 to a mounting plate and a fastening nut
- Temperature sensor
- Sealing rubber O-ring
- Orientation indications

The head contains:

- The electronic board
- One gland and one blind gland
- Grounding screw
- Fastening screw to the transducers

Section 3 Mechanical Installation

Installation procedure	page 7
Mounting considerations	page 7
Moisture and water condensation	page 8
Physical mounting	page 17

3.1 Installation procedure

- Make sure all required documentations are available: Application Evaluation Form (AEF) and Vessel Drawings.
- Compare locator suggestion or mounting location as suggested by Emerson™ with the actual Rosemount™ 5708 mounting positions.
- Perform manual measurements of the vessel dimensions, and compare results to the drawings.
- Check 24 Vdc input to all Rosemount 5708.
- Check RS-485 link between Rosemount 5708 and the other side. Make sure the resistance between D+ and D- is $60 \pm 5\% \Omega$.
- Check 4-20 mA connection to the local PLC. Perform Current Simulation from the Rosemount 5708 connected to the PLC.
- Power up the Rosemount 5708 and check polling address.
- Set polling address. In daisy chain connection make sure that each Rosemount 5708 has a different polling address and one of the Rosemount 5708 is set with polling address of 00.
- In case of daisy chain connection, write the polling addresses on the vessel drawings for all Rosemount 5708.
- Verify every Rosemount 5708 for proper functioning after power up. This can be verified by connecting each device directly to a computer.
- Verify sound signals transmission from all Rosemount 5708.
- Get material status (level/distance/volume) according to the process manager.
- Get all required information from the process manager in order to complete the Rosemount 5708 configuration.

3.2 Mounting considerations

This chapter describes the necessary steps for proper installation of the Rosemount 5708 beginning with important pre-installation considerations such as environmental conditions, correct positioning and orientation, through the mounting and configuration process.

3.2.1 Location and positioning guidelines

Choosing the proper location to the unit should consider every aspect of the vessel and contained materials, including the silo or vessel dimensions, type of material and angle of repose, locations of filling and emptying points, maximum level of material, internal construction and moving parts and any other consideration which may possibly affect the performance.

Note

It is strongly recommended to install the unit according to the *Locator* PC software results provided by the factory for installation location and positioning. Contact Emerson Customer Support for assistance.

Moisture and water condensation

Use the recommended cable gland and tighten the cable connection. For additional protection against moisture, lead the connection cable downward in front of the cable entry. Rain and condensation water can thus drain off. This applies mainly to mounting in areas where moisture is expected (e.g. by cleaning processes), or on cooled or heated vessels.

Pressure

The process fitting must be sealed in the case of a low/high pressured vessel. Before usage, verify that the sealing material is resistant to the stored medium. The maximum allowed pressure is indicated on the type label of the sensor.

Installation location

Choosing the proper installation location for the unit is an important part of the installation process. The wrong mounting location may result in erroneous measurements or loss of performance.

The following factors must be taken into consideration while choosing the installation position:

- Vessel dimensions
- Filling and emptying point locations
- Internal structure or support

Other restrictions related to the proximity of noisy devices (such as electrical motor) and any other element which may affect the proper operation of the Rosemount 5708.

Note

When mounting the Rosemount 5708, do not install it near the vessel wall. Installing it near the side wall will result in bad performance and will not be supported. The Rosemount 5708 cannot be mounted at a distance less than 24-in. (600 mm) from the wall or filling points.

Installing at the center of the vessel is not recommended, since the perfect symmetry from all sides toward the Rosemount 5708 may affect the resolution of the echo.

3.2.2 Rosemount 5708 orientation

Mounting direction

Mounting at a specific direction is important. The ridge on the antenna and the notch on the top of the thread (representing antenna no.1) should be directed toward the center of the vessel.

Figure 3-1. Mounting Direction 0° Indication toward Vessel Center

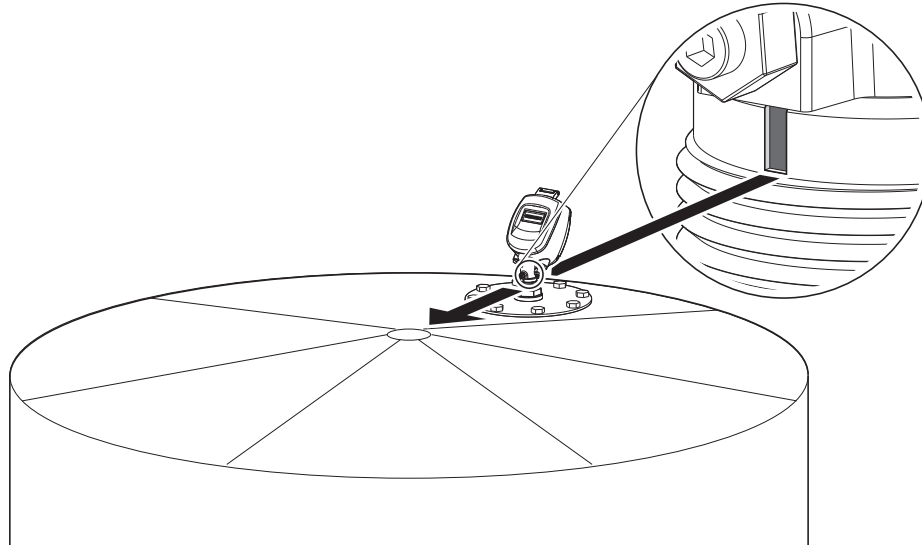
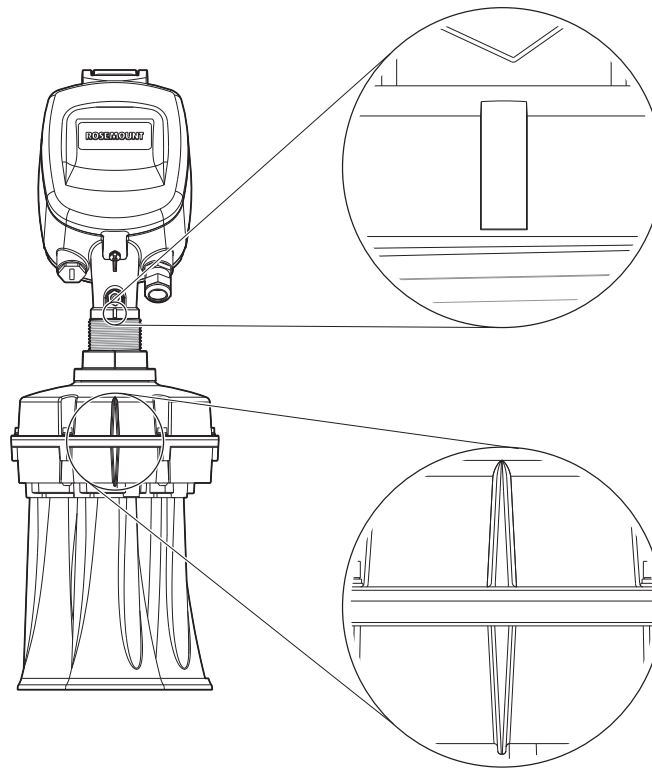

Figure 3-2. The 0° Indication



Standpipe mounting

When mounting using a standpipe it should be assembled and positioned at a height that leaves at least 0.4-in. (10 mm) below the standpipe, for the antenna end protrudes, as shown in [Figure 3-3](#).

Figure 3-3. Standpipe Mounting

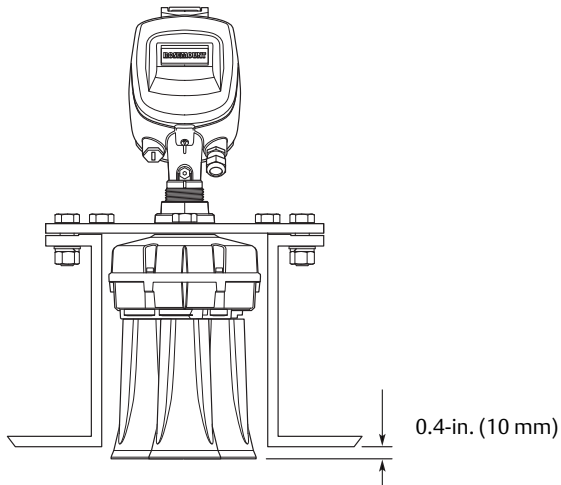

Note

Any obstruction as well as rails, frames or support beams should never interfere with the acoustic beam transmitted and received, as shown in Figure 3-4.

Figure 3-4. Avoid Interference with the Acoustic Beam

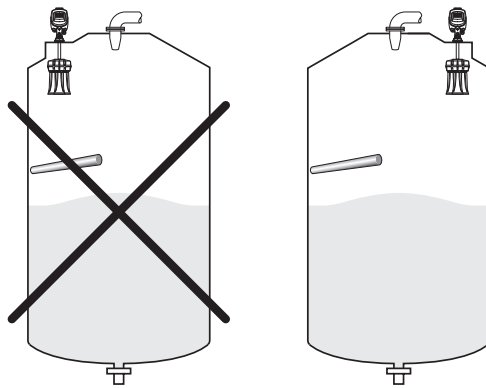

Inflowing material

Do not mount the Rosemount 5708 in or above the filling stream, or close to the stream, or in the filling stream. The Rosemount 5708 should be located with a clear line of sight to the top of the material at high levels, where it will not be affected by the filling stream or the noise it creates.

Figure 3-5. Inflowing Material

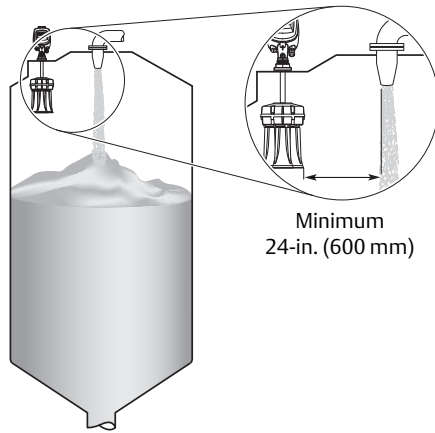

When choosing the installation location, consider the filling and emptying points and maintain at least 24-in. (600 mm) from the filling point.

Fitting

The fitting area should be prepared to ensure the antennas are positioned perpendicular to the ground, as shown in Figure 3-6.

Figure 3-6. Keep the Antennas in Vertical Position to the Ground

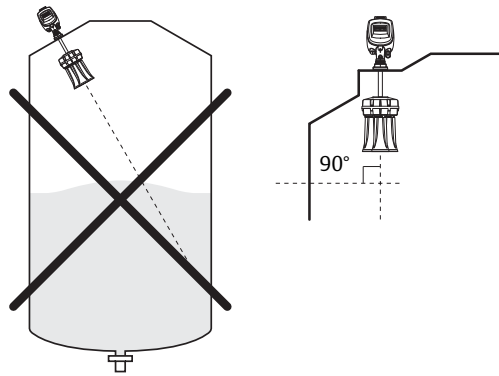

3.2.3 Mounting location

- Mount Rosemount 5708 perpendicular to the ground.

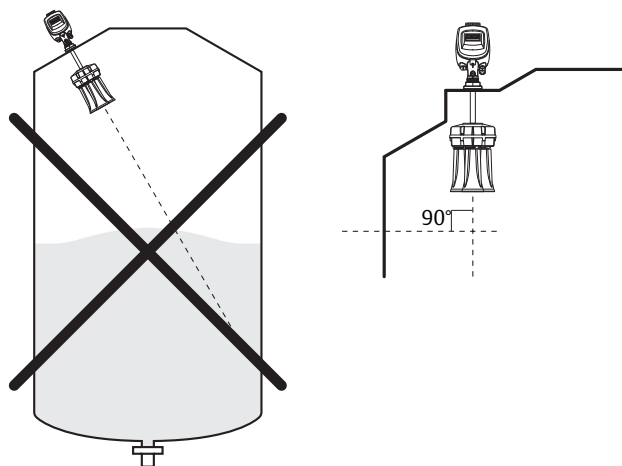

- Keep necessary distance from side wall.

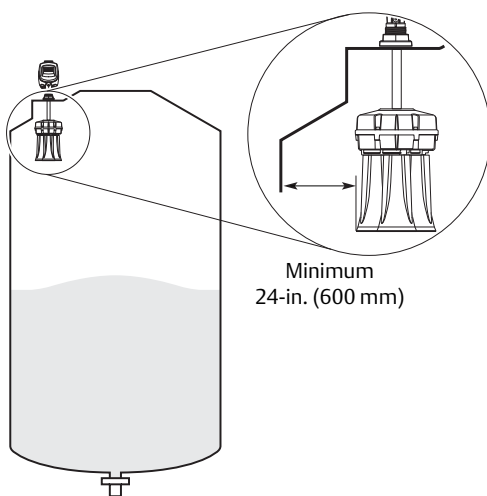

- Keep necessary distance from filling points.

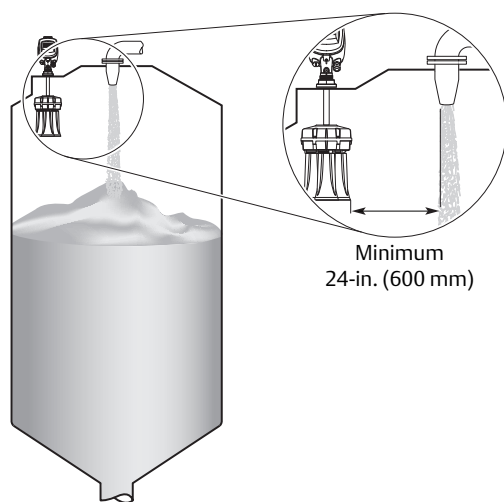

- Make sure there is no obstacle below the Rosemount 5708.

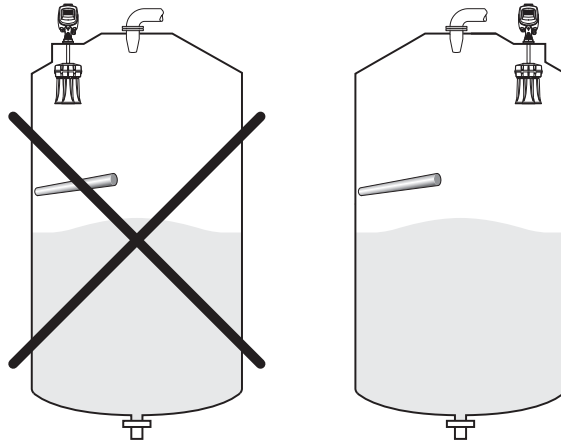

- In the case of standpipe mounting, assemble and position the Rosemount 5708 at a height that leaves at least 0.4-in. (10 mm) below the standpipe for the antenna end to protrude.

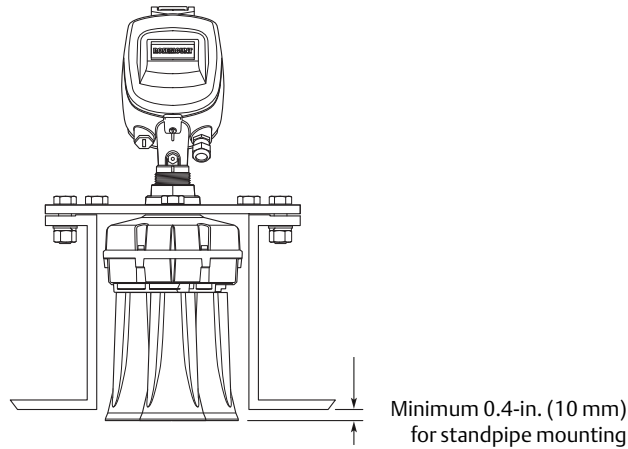

3.2.4 Site preparations

Prior to installation, complete and verify the site preparations described in this section. For optimal installation, ensure the Rosemount 5708 can be positioned and fitted according to the guidelines in “Mounting location” on page 12.

Recommended tools for installation:

- A set of small precision screwdrivers (for the terminal blocks)
- 13 mm open wrench
- 4 mm Hex key (preferably with a handle)
- Large adjustable wrench
- Wire cutter, pointed pliers, insulating tape
- Laser measurement device or equivalent
- RS-485 to USB converter, including drivers
- 120 Ω (RS-485) resistor
- 250 Ω (HART®) resistor
- PC or laptop
- DC voltmeter and Ohm meter

Complete the following steps before installing the Rosemount 5708.

Power

- Make sure grounding is done properly. Connect one end of the cable shield to the power ground. It is highly recommended to have the same potential grounding to all the Rosemount 5708.
- Prepare a 24 Vdc power supply near the Rosemount 5708 mounting location.
- Make sure that you use proper cables for wiring. The Rosemount 5708 is a 4-wire device. The voltage supply and data output (4-20 mA) are carried along two separate two-wire connection cables.

Communications

- For RS-485 communication, use shielded, twisted-pair cables with 120 Ω impedance. Make sure the cables are approved for RS-485 communications.
- Route communication cables in proper conduits. Use a proper cable type.
- For 4-20 mA communication, use shielded, twisted-pair, low resistance cables. Make sure the cables are rated for analog signals.
- For daisy chaining, a single 4-wire cable can be used, both for RS-485 and the 24 Vdc power supply.

3.2.5 Site and installation information

The information listed on these pages is necessary for configuration of the device.

Material characteristics

Material name:			
Material density:	<input type="checkbox"/> lbs/ft ³	<input type="checkbox"/> tons/m ³	Angle of repose:
Max. temperature:	<input type="checkbox"/> °F	<input type="checkbox"/> °C	Maximum pressure: <input type="checkbox"/> Bar <input type="checkbox"/> PSI

Vessel type and dimensions

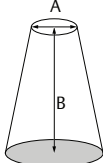
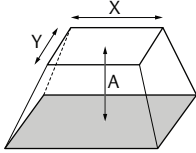
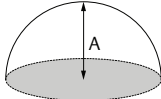
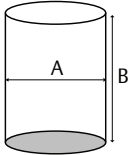
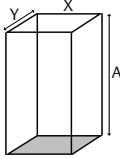
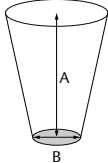
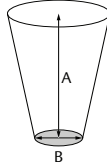
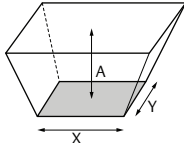
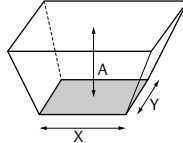
Vessel details ⁽¹⁾	<input type="radio"/> ft <input type="radio"/> m	
Vessel type	Cylindrical	Rectangular
Top shape	<input type="radio"/> Flat <input type="radio"/> Cone Top diameter (A): _____ Height (B): _____ 	<input type="radio"/> Flat <input type="radio"/> Pyramid Height (A): _____ X: _____ Y: _____ 
	<input type="radio"/> Dome Height (A): _____ 	
Center shape	<input type="radio"/> Cylinder Diameter (A): _____ Height (B): _____ 	<input type="radio"/> Cube Height (A): _____ X: _____ Y: _____ 
Bottom shape	<input type="radio"/> Flat <input type="radio"/> Cone Height (A): _____ Bottom diameter (B): _____ 	<input type="radio"/> Flat <input type="radio"/> Cone Height (A): _____ Bottom diameter (B): _____ 
	<input type="radio"/> Pyramid Height (A): _____ X: _____ Y: _____ 	<input type="radio"/> Pyramid Height (A): _____ X: _____ Y: _____ 

1. Required Field - Accurate Vessel dimensions are required to allow optimal Rosemount 5708 location determination.

Vessel details

Internal structure like: Ladder, pipe, window, screw, door, rail, support beam or any other obstacle which is visible to the 5708 scanner. Drawings should be available.		
Internal movement:	<input type="checkbox"/> YES <input type="checkbox"/> NO	If yes, please describe:

Rosemount 5708 and filling locations

	X	Y	Offset from roof
1st Rosemount 5708 location:			
2nd Rosemount 5708 location:			
3rd Rosemount 5708 location:			
Filling location:			

Figure 3-7. Filling Port Locations

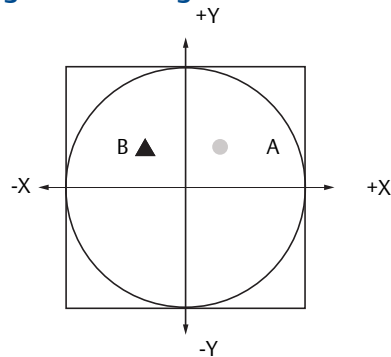

A. Rosemount 5708 (X1, Y1)
B. Fill (X2, Y2)

- When mounting more than one Rosemount 5708 on one silo the location of every device must be specified.
- When the application has more than a single filling point, all other filling points must be specified as well.

Full and empty calibration

- Full and empty calibration levels are measured from the top of the vessel.
- The full and empty calibration levels represent the 20 mA (100%) and 4 mA (0%) of the volume respectively.
- The Rosemount 5708 has a 20-in. (0.5 m) dead zone starting from the top part of the antenna assembly.

Figure 3-8. Full and Empty Calibration in Rectangular and Cylindrical Vessels

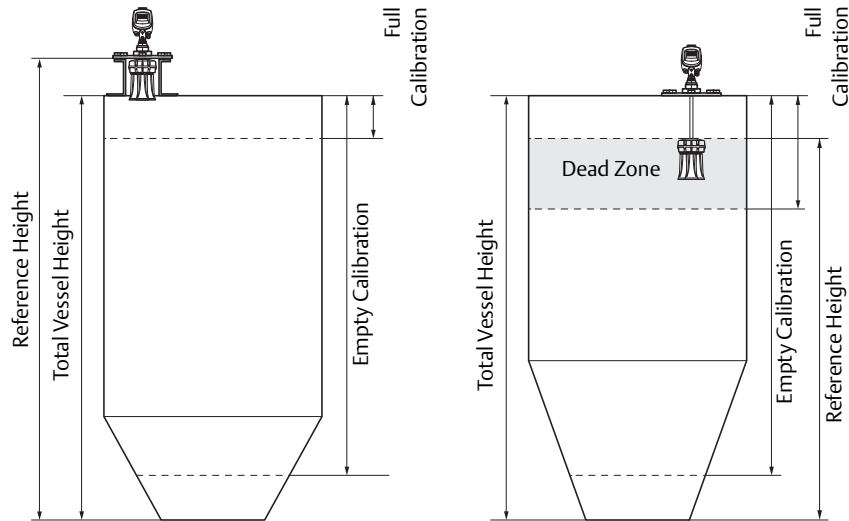

Full calibration:	<input type="checkbox"/> ft	<input type="checkbox"/> m
Empty calibration:	<input type="checkbox"/> ft	<input type="checkbox"/> m

Application process

Maximum filling rate:	<input type="checkbox"/> lbs/hour	<input type="checkbox"/> tons/hour
Maximum emptying rate:	<input type="checkbox"/> lbs/hour	<input type="checkbox"/> tons/hour
Total capacity when vessel is full:	<input type="checkbox"/> lbs	<input type="checkbox"/> tons

3.3 Physical mounting

Step 1: Check power and cables

1. Check the 24 Vdc with a voltmeter.
2. Check the resistance of the data communication lines.
3. Verify 60 Ω of resistance when connecting the 120 Ω resistors at both ends.

Step 2: Install the mounting plate

1. Verify the O-rings on the neck tube are in place.

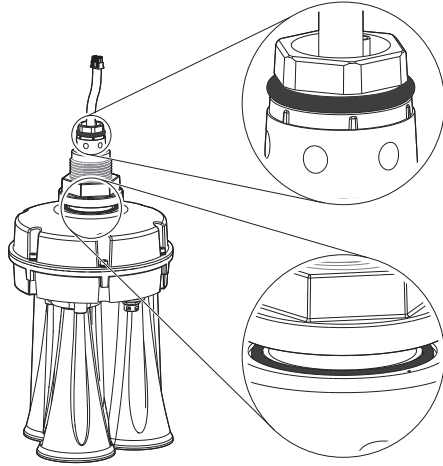

2. Remove the nut from the neck tube.

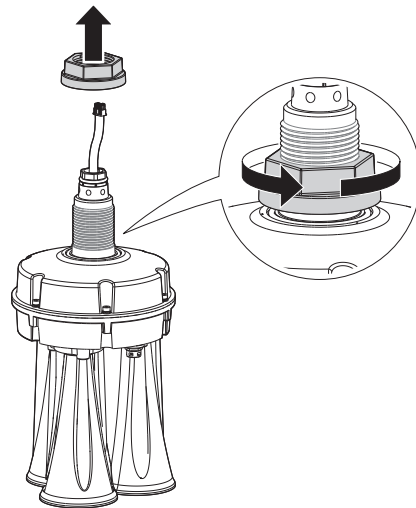

3. Place the mounting plate over the neck tube.

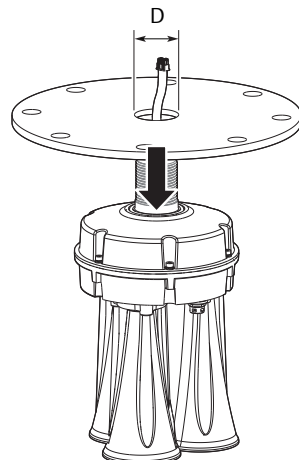

Note

Make sure the hole diameter (D) in the center is 2.05-in. (52 mm).

4. Replace the nut and tighten it over the neck tube to the mounting plate.

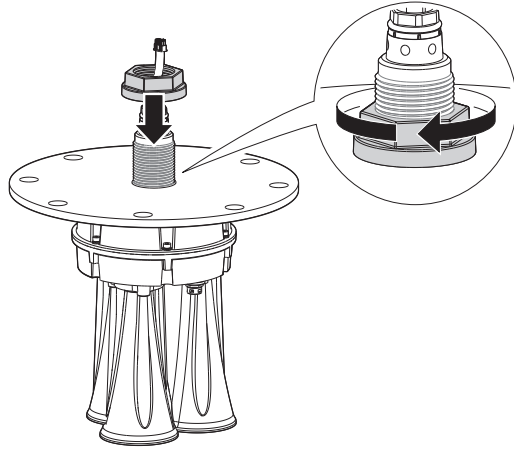

5. Lower the antenna and mounting plate into the fitting location on the silo.
6. Bolt the mounting plate onto the flange of the silo.

Step 3: Rotate antenna toward silo center

1. Slightly loosen the nut that connects the antenna with the mounting plate.

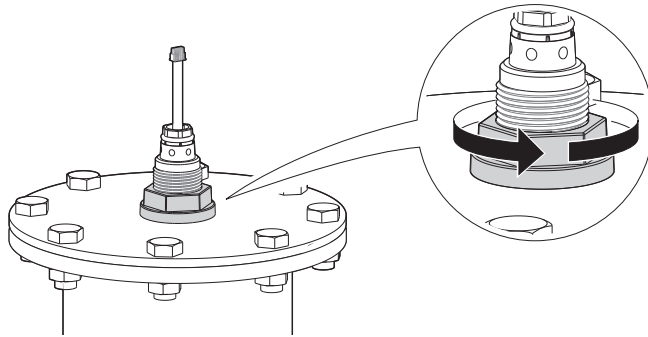

2. Rotate the antenna. **The notch on the top of the thread must be directed toward the center of the silo.**

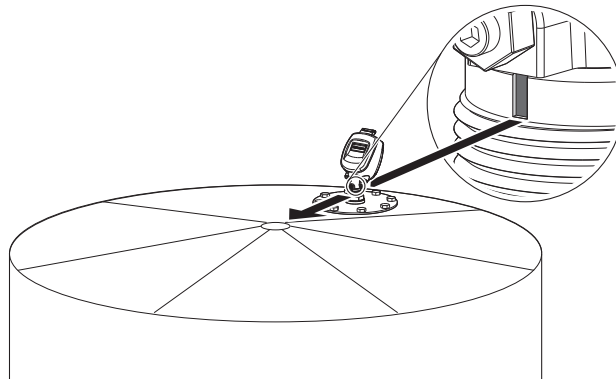

3. Tighten nut.

Step 4: Install head

1. Remove the rear panel.

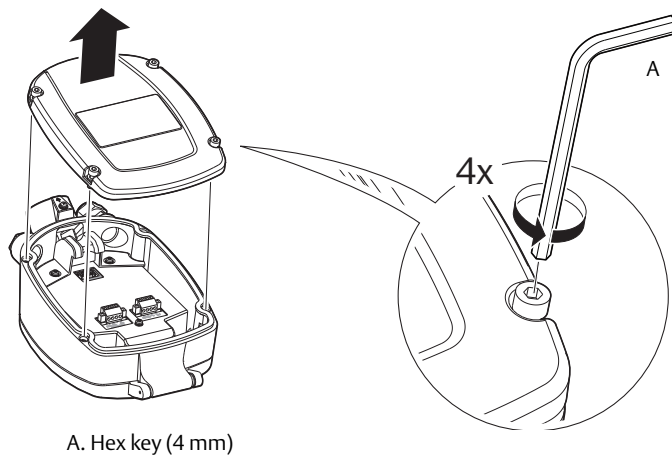

2. Remove the cable clamp.

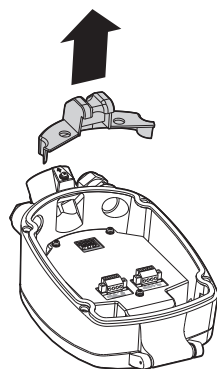

3. Verify the presence of the O-ring on the tube neck.

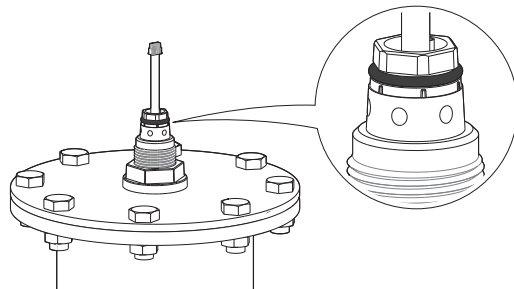

4. Gently insert the antenna cable through the Rosemount 5708 head.

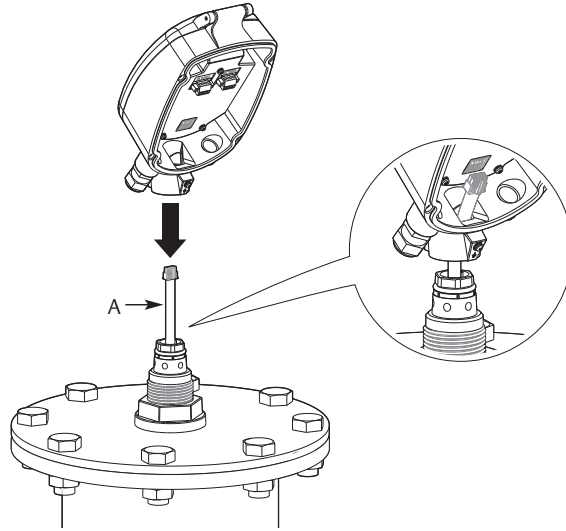

A. Antenna cable

5. Insert the Rosemount 5708 head onto the neck tube.
 - a. Rotate the Rosemount 5708 head to the desired direction. The head may be installed in six different positions. To avoid direction confusion, we can recommend to install the head in the same direction as the antennas.
 - b. Make sure to push the head all the way down until it fully contacts the top of the neck tube.

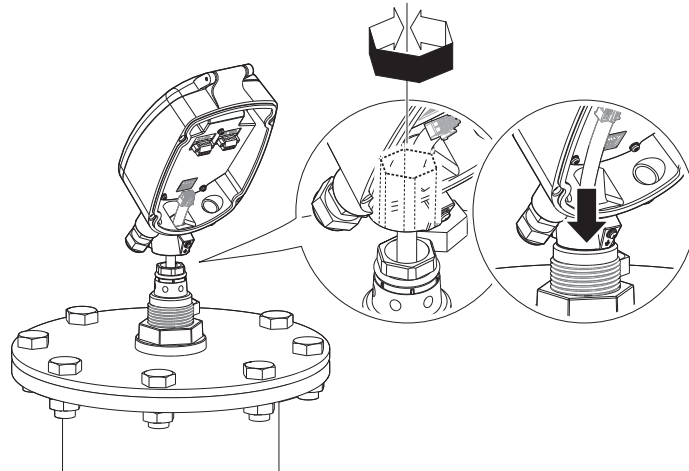

6. Tighten the front screw.

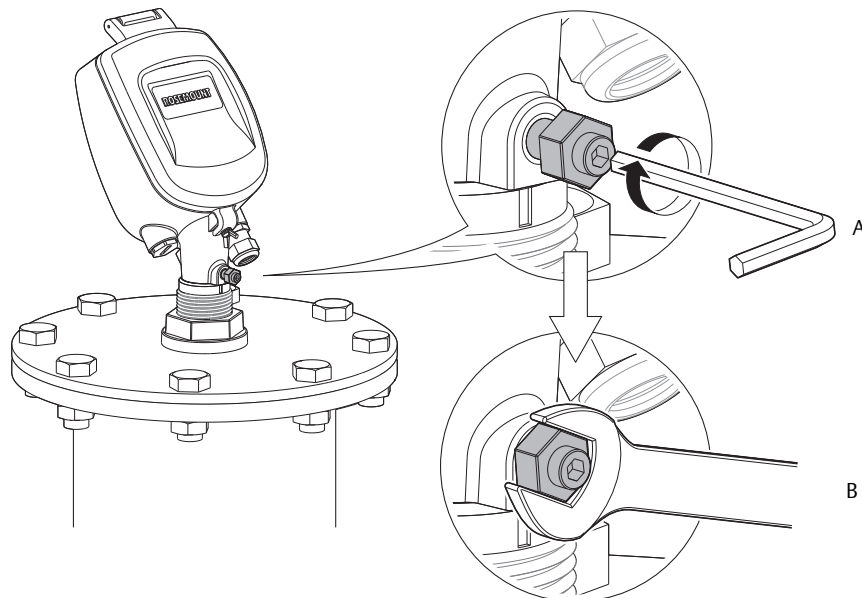

- A. Hex key (4 mm)
- B. Open wrench (13 mm)

7. Re-mount the cable clamp.

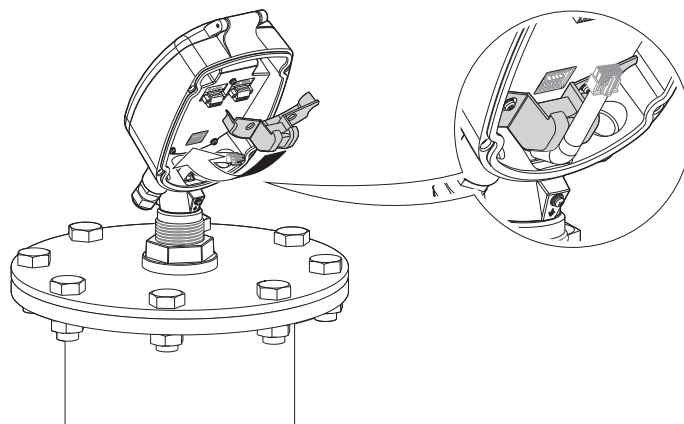

8. Gently connect the antenna cable connector. Make sure the latch is clicked and locking the connector.

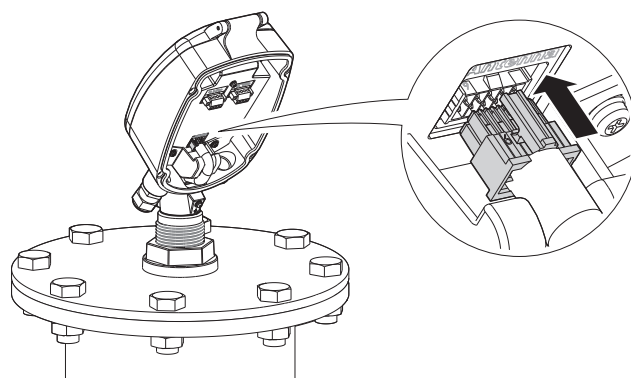

Section 4 Electrical Installation

Grounding	page 23
Cable selection	page 23
Hazardous areas	page 23
Wiring	page 24
Different connection methods	page 29

4.1 Grounding

The Rosemount™ 5708 must be grounded electrostatically:

- For internal grounding, use the power cable ground.
- For external grounding, use the earth potential equalization of the plant.

4.2 Cable selection

Make sure to select the proper cable for each application.

- For RS-485 communication, use shielded, twisted-pair cables with 120Ω impedance. Make sure the cables are approved for RS-485 communications.
- For 4-20 mA communication, use a low resistance cable and make sure the cables are rated for analog signals.
- For daisy chaining, a single 4-wire cable can be used, both for RS-485 and the 24 Vdc power supply. Make sure only to use a proper cable gaging (AWG).
- Use 8-13 mm (20-24 AWG) diameter cables to ensure proper and effective sealing of the cable gland entry opening.
- Select a cable suitable for application (indoor or outdoor) and safety certified according to national regulations.

4.3 Hazardous areas



In hazardous areas you should take note of the appropriate regulations, conformity and type of approval certificates of the sensors and power supply units. For further information on regulations, see [Appendix A: Specifications and Reference Data](#). For more information on sensors and power supply units, see “Wiring” on page 24.

4.4 Wiring

The units can be connected in different modes and configurations for different external systems such as PLC or DCS and communications on RS-485, Modbus® RTU, and also to RS-485 bus converting adapters to communication gateways such as Rosemount LinkPro for GMS or GPRS data relay and TCP/IP gateway. For in-depth details and explanations on wiring and communication, refer to “[Different connection methods](#)” on page 29.

Communications

Note

If electromagnetic interference is expected, usage of a screened and twisted wired cable is recommended for the signal lines, which should be connected to the ground reference.

⚠ CAUTION

Always observe the following safety instructions:

- Connections must be made only in the complete absence of line voltage.
- If over-voltage is expected, overvoltage arresters should be installed.
- Use only a safety-certified power supply with dual insulation between the primary and output for powering the unit. The power supply output rating must be limited to 18-32 Vdc, 1A for a single Rosemount 5708, and not to be connected to a DC distribution network.

Power supply

For detailed information on power supply specifications, refer to Rosemount 5708 [Product Data Sheet](#).
4-20 mA 4-wire: The power supply and signal current inputs must be carried over two separated pairs.

Connection procedure

For detailed information on the connection procedure, see “[Different connection methods](#)” on page 29.

Note

Use direct connection between the Rosemount 5708 and the plant (PLC/SCADA).
For a remote connection, use the Rosemount LinkPro remote connection module or a local PC/laptop computer as detailed in the following drawing.

⚠ CAUTION

Always observe the following safety instructions:

- Connections must be made only in the complete absence of line voltage.
- If over-voltage is expected, overvoltage arresters should be installed.
- Use only a safety-certified power supply with dual insulation between the primary and output for powering the unit. The power supply output rating must be limited to 18-32 Vdc, 1 A for a single Rosemount 5708, and not to be connected to a DC distribution network.

⚠ WARNING

The 4-20mA lines should NOT be connected in multi-drop.

Using the Rosemount 3DVision to communicate with the units allow the user to choose one of several communication types: RS-485, GSM, GPRS or TCP/IP, for more information and details regarding the communications, refer to the “[Communication methods](#)” on page 91.

Wire the Rosemount 5708

1. Verify the power supply is disconnected.
2. Loosen the compression nut of the cable gland entry.

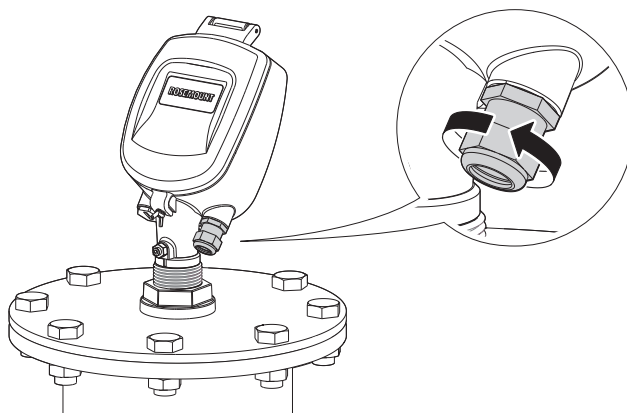

3. Insert the cable through the cable gland entry.

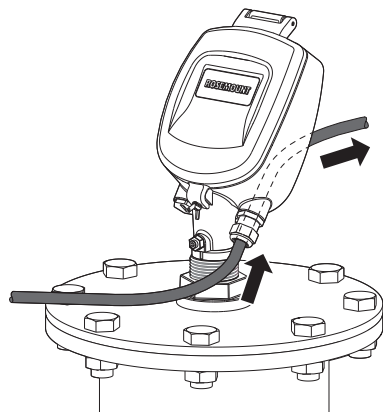

- Remove approximately 4-in. (100 mm) of the cable mantle and strip approximately 0.4-in. (10 mm) off the edge of each conductor.

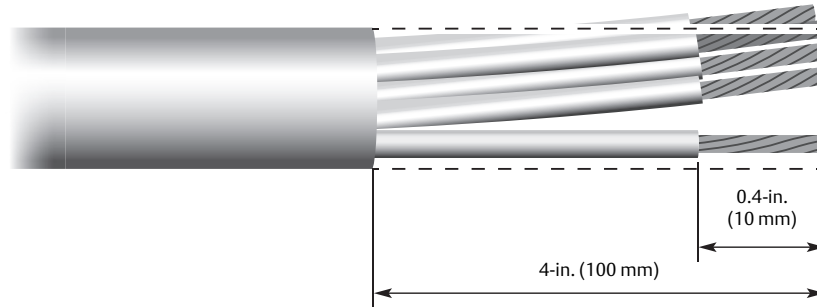

- Loosen the terminal block screws located inside the Rosemount 5708 head.

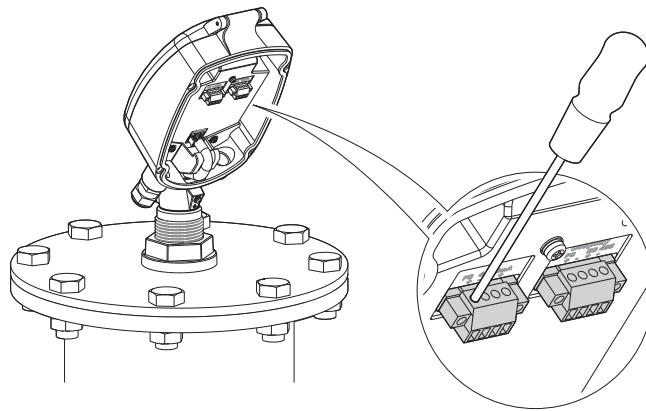

Note

The two terminal blocks can be pulled out by unfastening the two side screws to allow for easier wiring into the terminals. When inserting the terminal blocks back into the head, it is advised to fasten the screws back into the electronics card in order to avoid a loose connection and or operational problems.

- Connect the cable wires according to the wiring diagram. See “Different connection methods” on page 29 for different connection methods.

Note

When connecting the last Rosemount 5708 in the chain, a 120 Ohm resistor must be connected as well. See Figure 4-6 on page 31.

In any installation of the 5708 whether it is a single unit on a silo or multiple units, it is mandatory to use termination resistors at the ends of the daisy-chain connection.

One resistor must be on the last scanner on the chain (connected to the +/- terminals of the RS485 and the other resistor on the other end of the line before converting the RS485 bus to a different communication protocol such as USB, TCP/IP and others.

Figure 4-1. Wiring

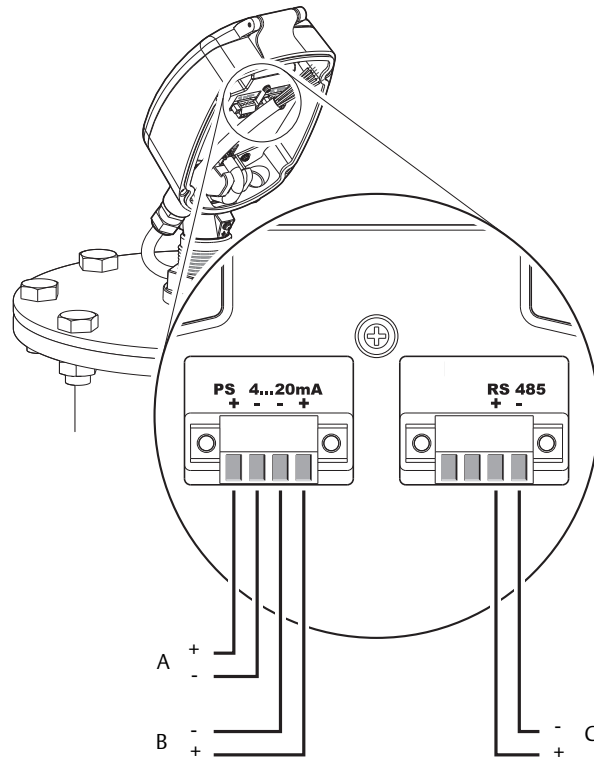

- A. Feed in power supply (18-32 Vdc)
- B. 4-20 mA communication terminals
- C. RS-485/Modbus RTU communication terminals

7. Connect the external ground terminal.

The Rosemount 5708 must be grounded electrostatically.

- For internal grounding, use the power cable ground.
- For external grounding, use the earth potential equalization of the plant.

Note

An internal cable grounding connection is also possible using the inner connection as shown below.

Figure 4-2. Grounds Screws

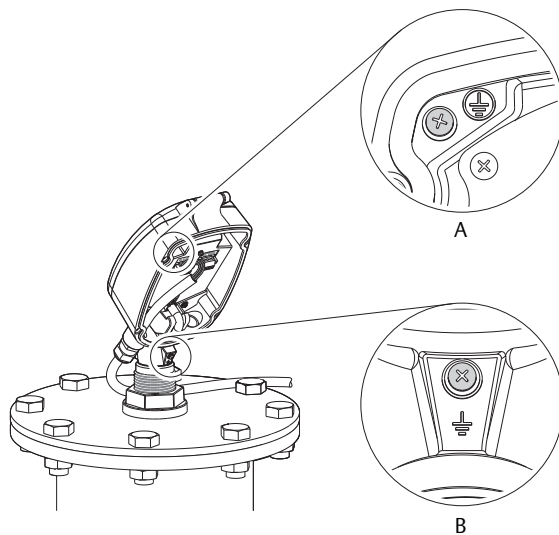

- A. Internal ground screw
- B. External ground screw

8. Tighten the compression nut over the cable gland entry opening.

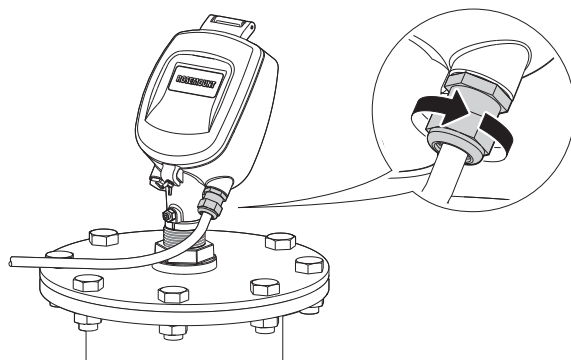

9. Attach the rear panel back to position and tighten the screws.

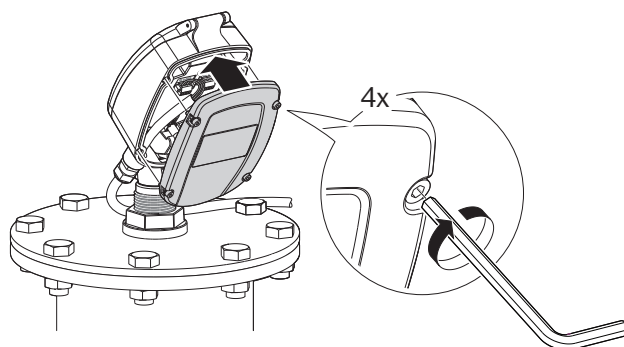

4.5 Different connection methods

4.5.1 4-20 mA connection

The Rosemount 5708 outputs the % of Volume as set in the configuration and between the Full and Empty calibration levels. The 4-20mA current output is available through ports 3 and 4 of the left green terminal block (as shown in Figure 4-3). Ports 3 and 4 are the negative and positive poles, respectively.

Figure 4-3. Port 3 and 4

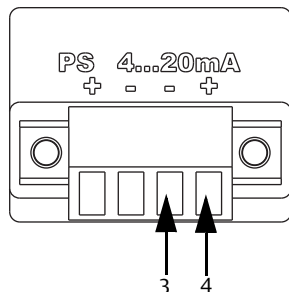

The 4-20mA line is connected directly from the Rosemount 5708 mounted on the vessel to the PLC/DCS/Display or any other device (as shown in Figure 4-4).

Figure 4-4. Rosemount 5708 Connected to PLC

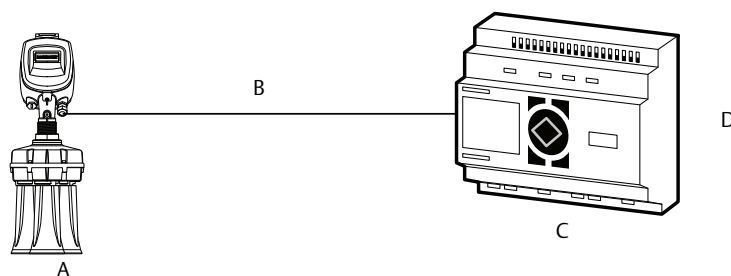

- A. Active
- B. 4-20 mA
- C. Passive
- D. PLC/Controller

Note

The maximum cable length of a 4-20 mA cable can be up to 2 miles (3 km).

⚠ WARNING

This type of connection is active and not passive, hence the Rosemount 5708 is the active module and the PLC should be the passive module.

Figure 4-5. Wiring the 4-20mA to Emerson™ Wireless THUM™ Adapter

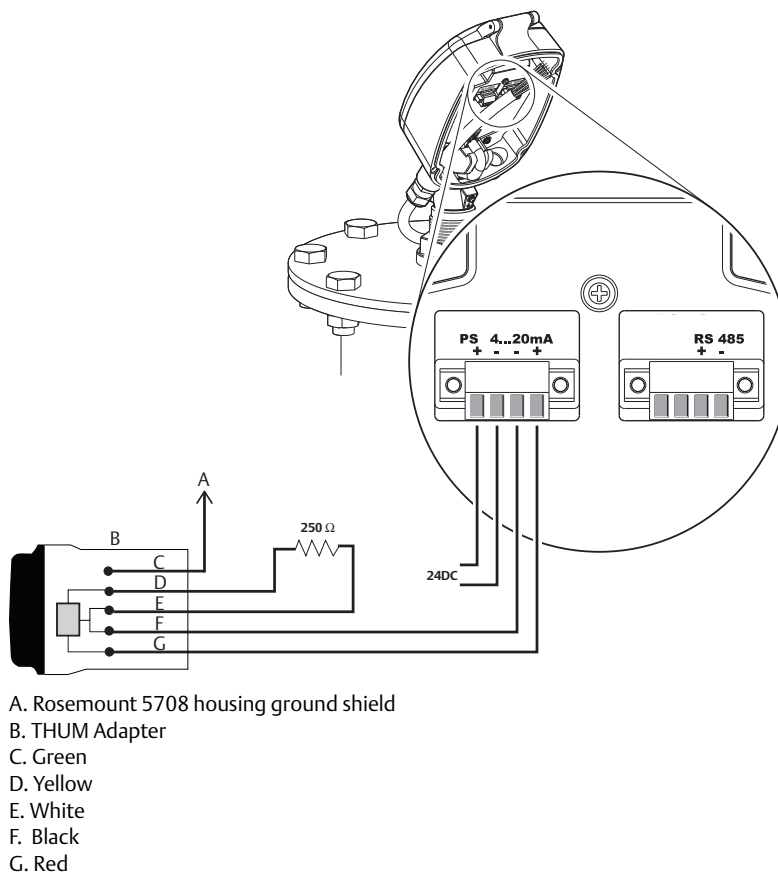

4.5.2 RS-485 communication

The unit includes an RS-485 communication port. This type of connection allows a PLC/DCS/laptop to communicate with the Rosemount 5708. It also allows a connection of multiple Rosemount 5708 in a system on the same RS-485 bus and communication with all devices using a single connection to the computer running the software.

It is required to use an appropriate cable rated for RS-485, the cable should be of twisted pair, have 120 Ω impedance and shielded. The total length of the cable should not reach 3280 ft (1000 m).

If multiple units of Rosemount 5708 is connected together, all devices must be connected in parallel mode in the RS-485 ports. Hence, all the '+' (positive) ports of the RS-485 should commonly be connected and all the '-' (negative) ports of the RS-485 should be connected commonly. The connection must be of Daisy-Chain type and have at each of the far ends of the chain 120 Ω resistor (such resistor is provided with the Rosemount 5708), as shown in [Figure 4-6](#).

The communication cable must be grounded at one side. This ground needs to be the same grounding as the power supply ground.

Each Rosemount 5708 must be configured with a different polling address.

Figure 4-6. Rosemount 5708 Connection

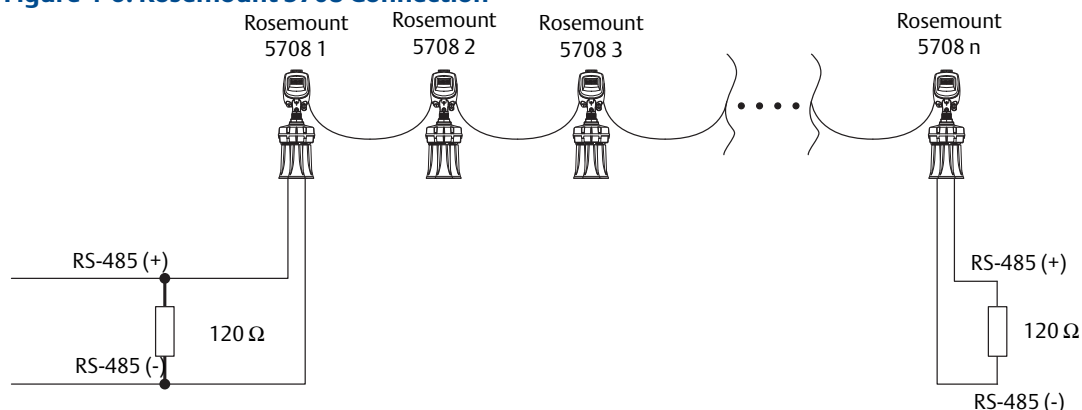

4.5.3 Communication using the Rosemount LinkPro

In all installations, the Rosemount 5708 can be connected to a GSM/GPRS modem in order to transfer the data over the cellular network. The Rosemount LinkPro should be connected on the RS-485 bus just like any Rosemount 5708, including cable and resistors as needed. For further details on wiring and establishing a connection, refer to the [Appendix D: Rosemount LinkPro Operating Instructions](#).

Note

In such communication mode, only one computer running the Rosemount 3D Vision software can be connected to the Rosemount 5708.

4.5.4 TCP/IP communication

The RS-485 bus can be converted to TCP/IP communication. TCP/IP to RS-485 converter installation should be done as with any Rosemount 5708, including the resistors and daisy-chain considerations.

For more information on how to convert and transfer the RS-485 data over TCP/IP, see “TCP/IP” on page 92.

Note

Consult the Emerson Technical Support team for assistance on the proper TCP/IP converter to use.

Section 5 Configuration - Rosemount 5708L

On-board configuration page 33
Setting the polling address page 34
Configuring the Rosemount 5708L page 35

5.1 On-board configuration

The Rosemount™ 5708L can be completely configured via the LCD display. It is also possible to configure the Rosemount 5708L by using the Rosemount 3DVision software.

Figure 5-1. User Interface



- ESC** Navigates back within a function menu. Continuous 3 second press exits to the default screen.
- +** Navigates upwards in the navigation list. Navigates right within a function.
- Navigates downwards in the navigation list. Navigates left within a function.
- E** Navigates to the right when within a function group. Stores a value once configured.

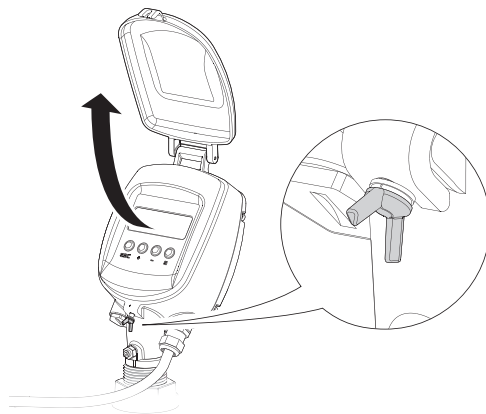

1. Connect power to the Rosemount 5708 and open the front cover.

The Rosemount 5708 initializes a self-test for about 30 seconds. The display remains blank during this time.

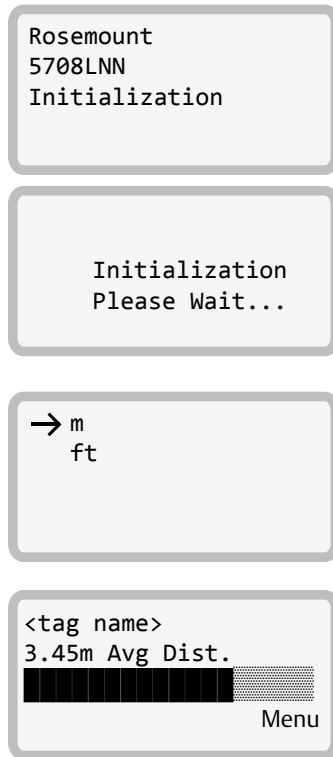

2. After initialization, the version screen appears.

According to the factory default settings, after power initiation or restart, a screen prompts for configuration.

In the main menu, select **Basic Settings**.
3. Use the `[+]` / `[-]` keys to switch between the options.
Press `[E]` to select and continue with the settings or `[ESC]` to exit to the main screen.
4. When the startup process is complete, the following screen appears showing the current average distance measurement. The top line displays the Rosemount 5708 tag name. By default, this line is empty.
Press `[E]` to enter the main menu.

5.2 Setting the polling address

Setting the sensor address is mandatory when multiple sensors are connected over an RS-485-Multidrop (daisy chain). Set the addresses prior to use of the Rosemount 3D Vision software.

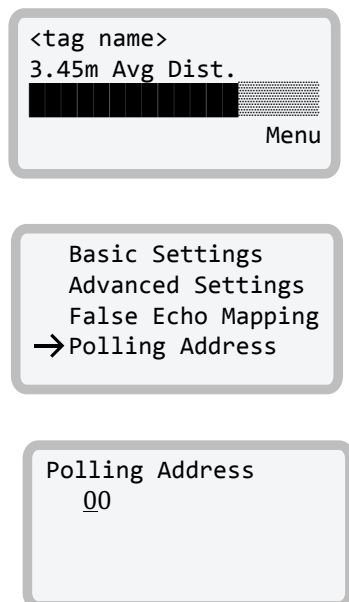

1. From the main screen, select the `[E]` key to enter the main menu.
2. In the main menu, use the `[+]` / `[-]` keys to scroll down to **Polling Address**.

Select `[E]` to switch to the Polling Address configuration screen.
3. Use the `[-]` key to switch between the two digits. Use the `[+]` key to modify the value.
The default polling address is 00. The polling address ranges from 00 to 63.
Select `[E]` to store the modified address and `[ESC]` to exit to the main screen.

5.3 Configuring the Rosemount 5708L

5.3.1 Basic Settings

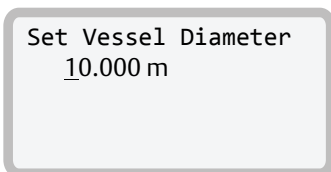
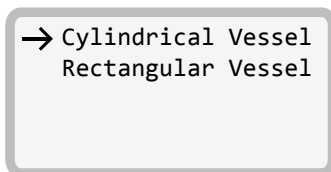
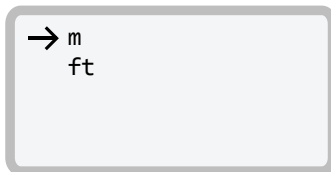
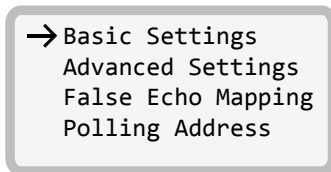
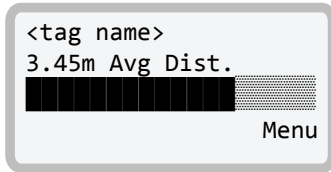

1. From the main screen, select the **[E]** key to enter the main menu.
2. In the main menu, scroll down to **Basic Settings**, using the **[↓]** key.
Select **[E]** to switch to the **Basic Settings** configuration screen.
3. Set the distance units, either meters (**m**) or feet (**ft**).
4. Set **Vessel Height** from the vessel bottom edge to the vessel top edge.
Use the **[←]** key to switch between the two digits. Use the **[+]** key to modify the value.
5. Select the vessel shape, either **Cylindrical** or **Rectangular**.
 - a. Use the **[+]** / **[−]** keys to switch between the options. Select **[E]** to continue.
 - b. If **Cylindrical** is selected, set vessel diameter.
Use the **[←]** key to switch between the two digits. Use the **[+]** key to modify the value. Select **[E]** to continue.
 - c. Set **Scanner Height** from the bottom edge of the vessel to the mounting plate (point above the antenna).
Use the **[←]** key to switch between the two digits. Use the **[+]** key to modify the value. Select **[E]** to continue.

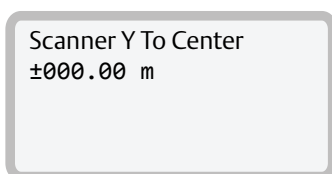
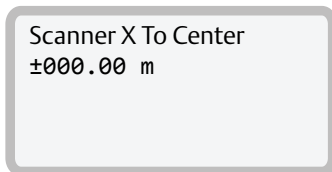
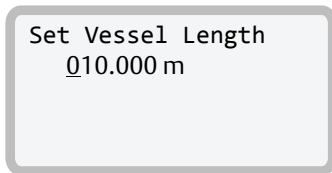
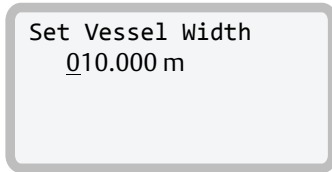
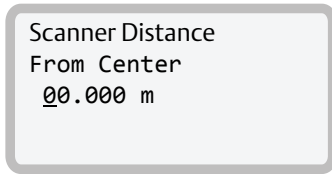

d. Set **Scanner Distance from Center**.
Use the key to switch between the two digits. Use the key to modify the value. Select to exit to the main screen.

6. If **Rectangular** is selected, set vessel width first (dimension on the x-axis).

a. Use the key to switch between the two digits. Use the key to modify the value. Select to continue.

b. Set **Vessel Length** (dimension on the y-axis).
Use the key to switch between the two digits. Use the key to modify the value. Select to continue.

c. Set **Scanner Height** from the bottom edge of the vessel to the mounting plate (point above the antenna).
Use the key to switch between the two digits. Use the key to modify the value. Select to continue.

d. Set the distance from the x-axis, see [Figure 3-7 on page 16](#).
Use the key to switch between the two digits. Use the key to modify the value. Select to continue.

e. Set the distance from the y-axis, see [Figure 3-7 on page 16](#).
Use the key to switch between the two digits. Use the key to modify the value. Select to exit to the main screen.

5.3.2 Advanced Settings

After configuring the Basic Settings, perform Advanced Settings configuration.

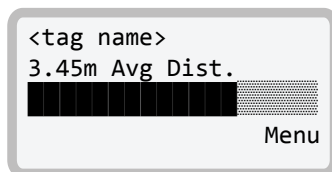

1. From the main screen, select the key to enter the main menu.

Basic Settings
→ Advanced Settings
False Echo Mapping
Polling Address

Set Distance
To Full Calibration
00.500 m

Set Distance
To Empty Calibration
20.000 m

Set adapter Angle
00

Slow Process
→ Regular Process
Fast Process

→ Celsius
Fahrenheit

→ Distance
Level
Volume
Analog Output
SNR

2. In the main menu, scroll down to **Advanced Settings**, using the key.
3. Select to switch to the **Advanced Settings** configuration screen.
4. Set the distance from the mounting plate (top of the antenna) to the **Full calibration point** / 100% level point. Use the key to switch between the two digits. Use the key to modify the value. Select to continue.
5. Set the distance from the mounting plate (top of the antenna) to the **Empty calibration point** / 0% level point. Use the key to switch between the two digits. Use the key to modify the value. Select to continue.
6. Select to keep the default setting.
Note: if using an angle adapter, set the angle value. Use the key to switch between the two digits. Use the key to modify the value. Select to continue.
7. Set the process rate using the key. Select to continue.

Make sure to always use **Regular Process**.

For the Slow and Fast Process options, contact your local customer service.
8. Set the temperature units using the key. Select to continue.
9. Set the displayed parameter desired for the main screen using the key. Select to exit to the main screen.

5.3.3 False Echo Mapping

When the configuration is finished, set False Echo Mapping.

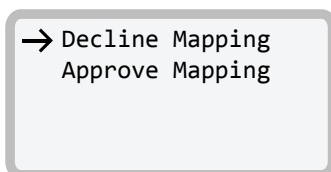
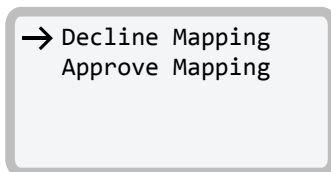
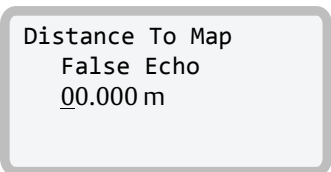
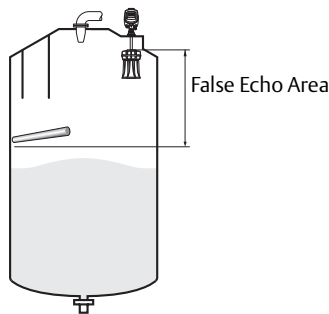
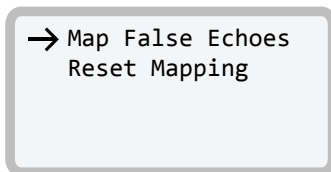
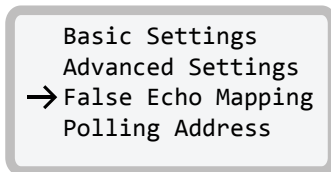
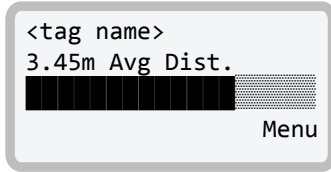

1. From the main screen, select the **E** key to enter the main menu.

2. In the main menu, scroll down to **False Echo Mapping**, using the **↓** key.

Select **E** to switch to the **False Echo Mapping** configuration screen.

3. Select **Map False Echoes** for automatically mapping all the false echoes up to a certain distance.
Or select **Reset Mapping** for deleting the stored mapped false echoes from the memory.

Use the **↓** key to go down the list. Select **E** to continue.

a. If **Map False Echoes** is selected, set the distance from the top of the antenna assembly to the end of the scanning point. Always make sure to map false echoes above material level. The recommended level is 3 ft. (1 m) above actual material level.

Use the **←** key to switch between the two digits. Use the **+** key to modify the value. Select **E** to continue.

b. Approve or decline the false echo mapping operation. Use the **↓** key to go down the list. Select **E** to continue.

c. If **Reset Mapping** is selected, approve or decline the operation. Use the **↓** key to go down the list. Select **E** to continue.

Section 6 Configuration - Rosemount 5708V and 5708S

On-board configuration	page 39
Setting the polling address	page 40

6.1 On-board configuration

For the Rosemount™ 5708V and 5708S only polling address configuration is done using the LCD display of the device.

The rest of the configuration is completed with the Rosemount 3DVision software. For further information, see [Section 7: Operation](#).

Figure 6-1. User Interface



- ESC** Navigates back within a function menu.
Continuous 3 second press exits to the default screen.
- +** Navigates upwards in the navigation list.
Navigates right within a function.
- Navigates downwards in the navigation list.
Navigates left within a function.
- E** Navigates to the right when within a function group.
Stores a value once configured.

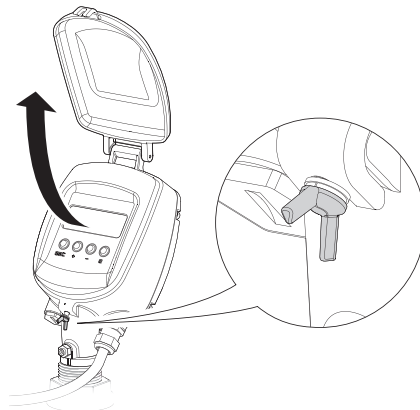

1. Connect power to the Rosemount 5708 and open the front cover.

A self-test will start and run for about 30 seconds. The display remains blank during this time.

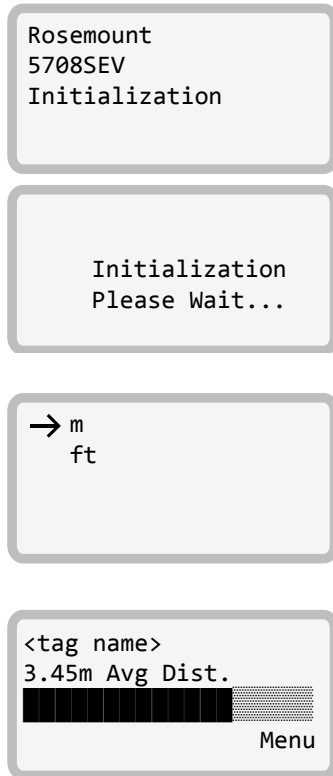

2. After initialization, the version screen appears.

According to the factory default settings, after power initiation or restart, a screen prompts for configuration.

In the main menu, select **Basic Settings**.
3. Use the / keys to switch between the options. Press to select and continue with the settings or to exit to the main screen.
4. When the startup process is complete, the following screen appears showing the current average distance measurement. The top line displays the tag name. By default, this line is empty. Select to enter the main menu.

6.2 Setting the polling address

Setting the sensor address is mandatory when multiple sensors are connected over an RS-485-Multidrop (daisy chain). Set the addresses prior to use of the Rosemount 3D Vision software.

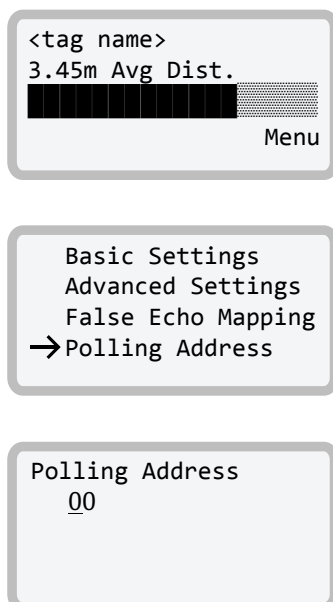

1. From the main screen, select the key to enter the main menu.
2. In the main menu, use the / keys to scroll down to **Polling Address**.

Select to switch to the Polling Address configuration screen.
3. Use the key to switch between the two digits. Use the key to modify the value.
The default polling address is 00. The polling address ranges from 00 to 63.
Select to store the modified address and to exit to the main screen.

Section 7 Operation

Rosemount 3DVision/3DMultiVision overview	page 41
Installing the Rosemount 3DVision software	page 45
First-time running	page 54
Software navigation	page 66
Advanced tools	page 91

7.1 Rosemount 3DVision/3DMultiVision overview

Rosemount™ 3DVision/3DMultiVision™ enables real-time assessment of bulk solids and powders, of any type or size, stored in storage vessels. The application periodically supplies information, providing the essential, real-time data required for critical decisions necessary for successful plant management.

Figure 7-1. Rosemount 3DMultiVision Output Example

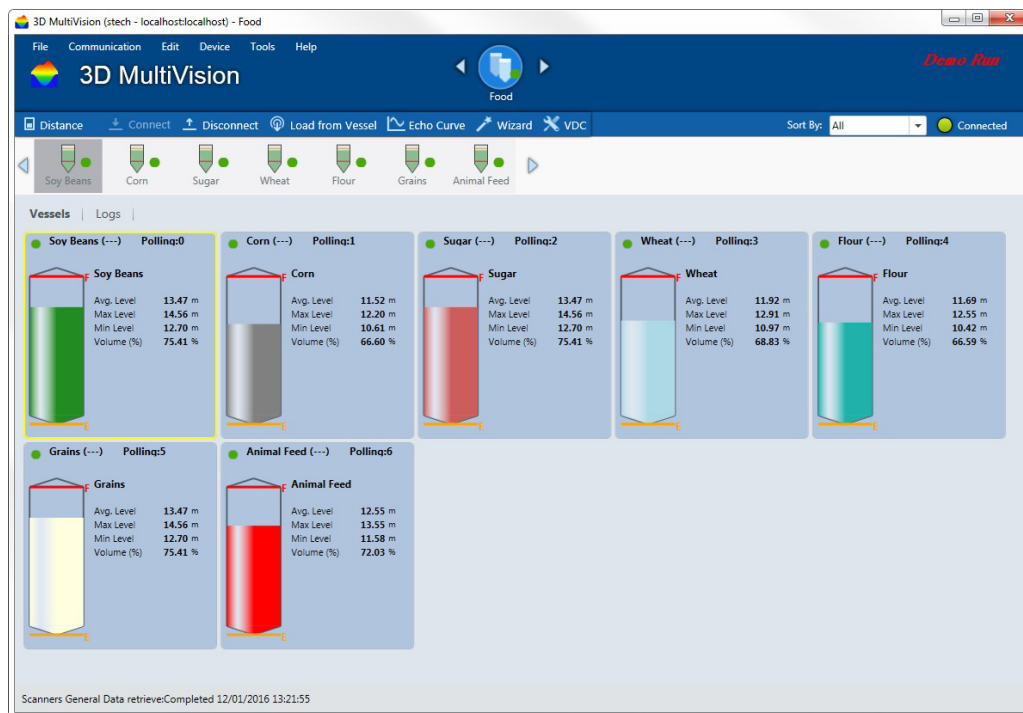

The Rosemount 3DVision works in conjunction with Rosemount 5708 providing measurement data to a Windows™ based computer running the programs. The program continuously collects data from the monitored vessel and generates reports. The reports are used to increase operational efficiency, and provide the site managers with valuable real-time and historical information for effective decision making.

Rosemount 3DMultiVision enables usage of a function on groups of vessels, even across multiple sites. Rosemount 3DMultiVision works in conjunction with the Rosemount 5708 to collect data from all monitored vessels in all sites and geographic regions, to combine and merge the data, and to generate and analyze various types of reports.

Basically, both 3DVision and 3DMultiVision have the same capabilities, the one major difference is that the 3DMultiVision allows the user to view measurements from all vessels in one screen while in the 3DVision, it is possible to view only one vessel at a time.

7.1.1 Server-client architecture

The Rosemount 3DVision/3DMultiVision software is comprised of two components: a server and a client.

The Rosemount 3DVision Server runs on a designated computer and is connected directly or remotely to every Rosemount 5708 in a single, local site or in multiple remote sites. The data is stored on the server computer which generates the reports, collects and stores readings, and transfers the information to all connected Rosemount 3DVision clients. The server computer should be running and logging at all times.

The Rosemount 3DVision Client is a graphical and interactive program, allowing the user to receive online measurement data, view a 3D visualization of the material stored in the vessels, add or remove sites, vessels, and Rosemount 5708, and manage alerts and reports. The Rosemount 3DVision Client supports several authorization levels of different privileges such as full-management authorized system administrators, technicians, and view-only operators.

7.1.2 Multi-client

The Rosemount 3DVision software is designed to work in a multi-client environment. Authorized users, connected to the same LAN or via external connections (WAN), have access to both real-time and historical data for all devices connected to the server.

Figure 7-2. Rosemount 3DVision Computer Topology

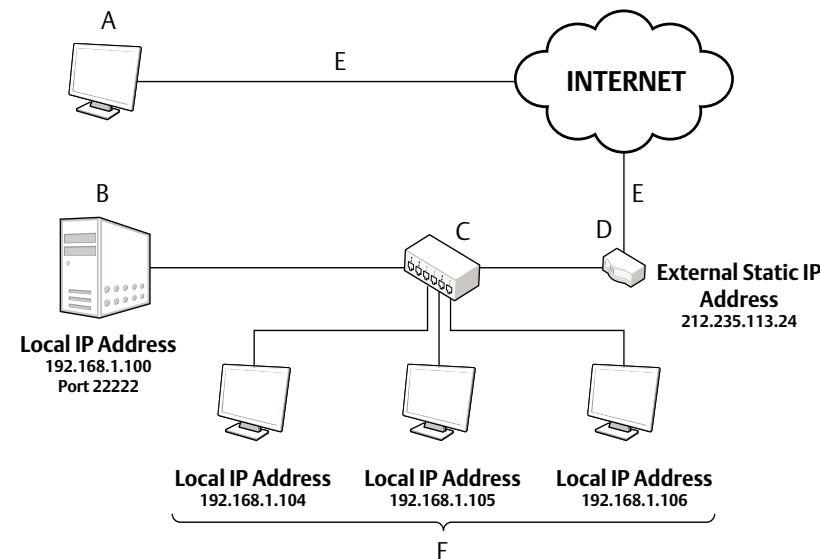

- A. Remote 3DVision Client
- B. Rosemount 3DVision Server Computer
- C. Switch
- D. Router
- E. Internet
- F. Local Client (LAN)

Figure 7-3. Rosemount 3D Vision Server Connection Example

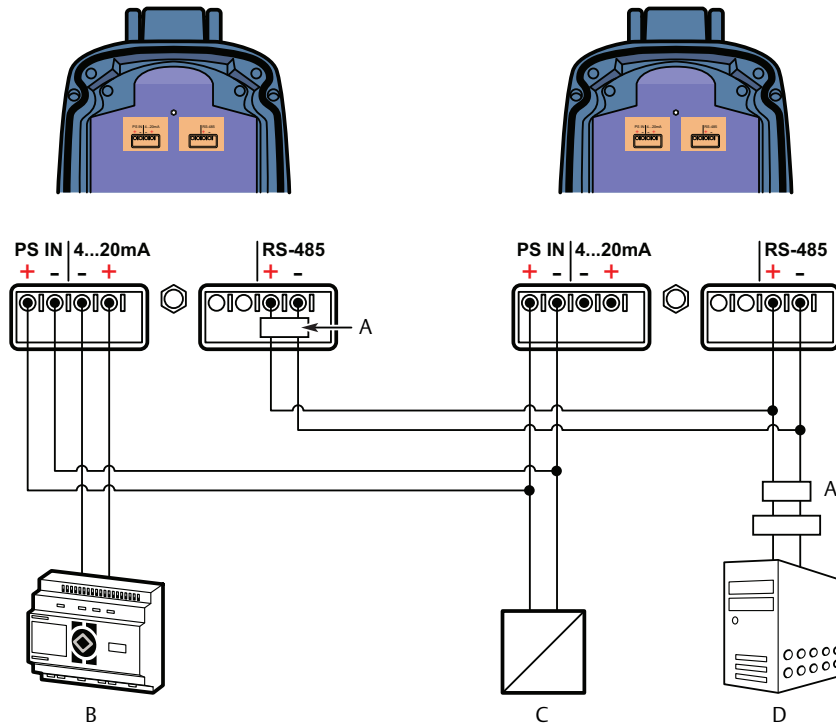

- A. 120 Ω resistor
- B. PLC / DCS / Display
- C. 24 Vdc power supply
- D. Rosemount 3D Vision Server
- E. RS-485 to USB converter

The Rosemount 3D Vision Client application can connect to multiple Servers simultaneously. This feature enables the user to view data from multiple plants (without relation to geographical location) in a single screen. In addition, each Rosemount 3D Vision Server can connect and supply information to an unlimited number of Clients. These features enable high flexibility in inventory management and amount of personnel reviewing the information.

When more than one client is logged as technician, only one can perform changes to the vessel or the configuration. If, for example, one user opened the Configuration Wizard, the second user that opens the wizard will get the following error message:

Figure 7-4. Setting Information Done by Another User

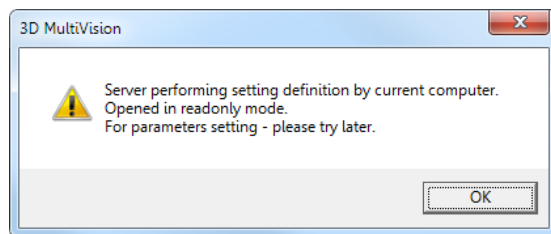

7.1.3 System requirements

Refer to Rosemount 5708 [Quick Start Guide](#) for the Software Installation requirements for the server and client.

7.1.4 Network considerations

When installing the Rosemount 3DVision Clients and Servers in a secured network or when it is needed to access the Rosemount 3DVision Server from an external connection (WAN – Wide Area Network) it is required to open TCP Ports in Firewalls, Routers or other devices or applications that might block such communication.

The required TCP Ports are:

- 22220 – Control Port
- 22221 – Used for data Connection
- 22222 – Connection of Rosemount 3DVision Client to Server
- 22223 – Logs Download Data Port

Additional TCP ports may be required when integrating the 3DVision to SCADA/DCS system using Modbus communication protocol. See [Table 7-5 on page 72](#) Server options - SCADA Configuration, and [Figure 7-33 on page 77](#).

7.2 Installing the Rosemount 3DVision software

After completing the recommended preparations listed in the prerequisite information section below, the Rosemount 3DVision program is ready to be installed.

7.2.1 Required information

Gather the following information related to each Rosemount 5708 connection prior to the software installation and Rosemount 5708 connections:

- Polling address of each Rosemount 5708 [00 – 63]
- Method of connection to the Rosemount 3DVision Server computer
- Vessel dimensions, filling points and Rosemount 5708 location
- Product information – Density (for mass calculation) and product name

For more information on various methods of connecting to the Rosemount 5708, refer to [Section 4: Different connection methods](#).

7.2.2 Installation

For initial configuration, it is recommended to install both Rosemount 3DVision Server and Rosemount 3DVision Client on the same computer. However, it is possible to install the Rosemount 3DVision Server and Client on separate computers and connect to them accordingly.

If you are using the Rosemount System Controller unit, skip to “[Starting Rosemount 3DVision Server and Client](#)” on page 51.

It is recommended to have an active Internet connection during the installation process, as updated versions of Microsoft .NET Framework and other components may exist.

Note

Do not install the server application on remote computers. It is not necessary and may result in slow operation.

To install the software:

1. Insert the USB flash drive into the USB port or download the installation file from the support page in [Emerson website](#) and execute the “Installer.exe” file. The installation wizard starts automatically and the Rosemount 3DVision setup wizard appears.

If the installation program does not start automatically, run “Installer.exe” from the flash drive.

2. Select **Install Rosemount 3DVision**.

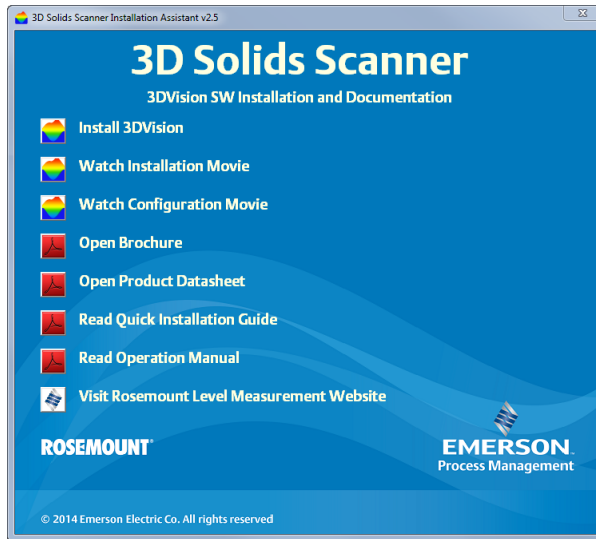

Note

If the computer where Rosemount 3DVision is being installed does not have Microsoft .NET Framework 4.0 installed, the Rosemount 3DVision setup wizard automatically detects and prompts you to install this component. The installation file of the .NET Framework is provided in the flash drive supplied with the software and Rosemount System Controller.

3. Select your preferred language and **OK** to proceed. The installer's welcome box appears.
4. Select **Cancel** to stop the installation process and close the window.
OR
Select **Next** to proceed.

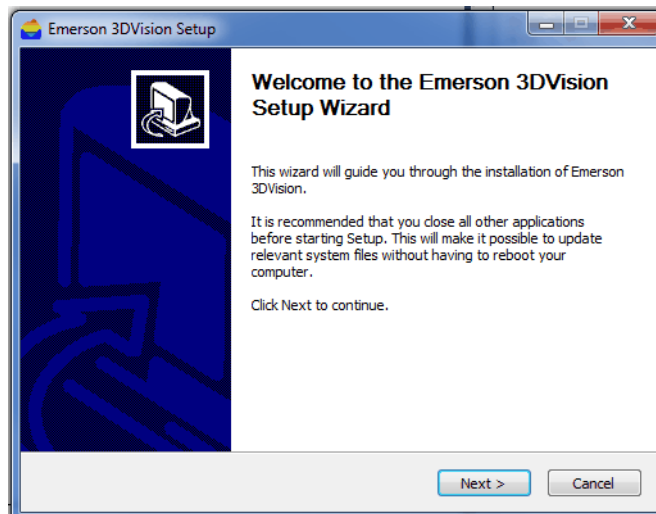

5. Select **Full install** and select **Next** to install Rosemount 3DVision with all available features. The setup wizard completes the software installation.
OR
Select **Custom install** for remote client installations, and select **Next** to change the installation folder and select applications to install.

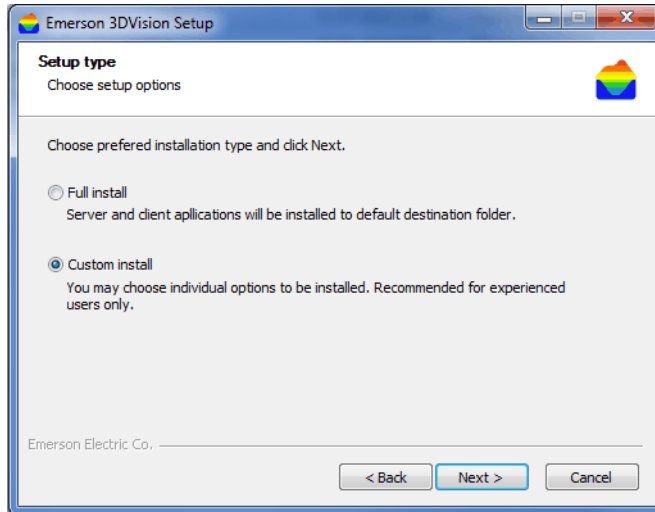

6. Select **"I do not accept the ..."** to cancel and exit the installation.
OR
Select **"I accept the ..."** and select **Next** to proceed with the installation.

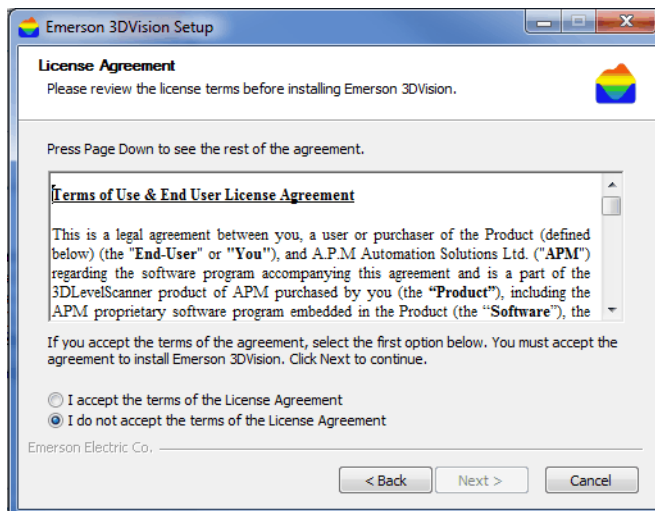

7. Select for which users the software should be available to:
 - **Install for all users** to make the software available to all computer users.
 - **Install for current user** to make the software available to the present user account only.

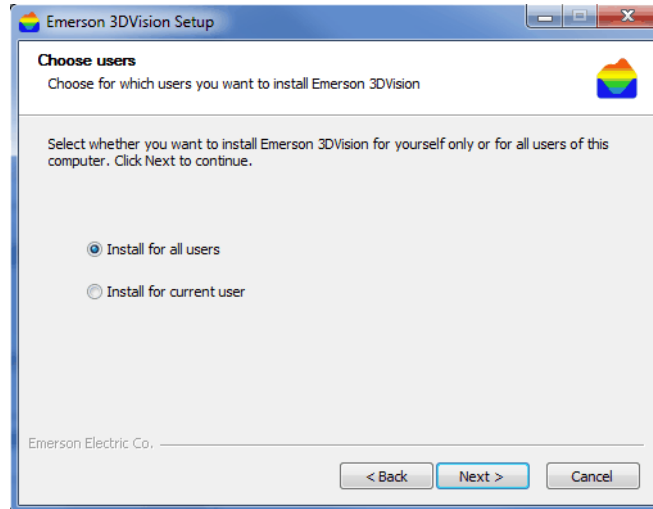

8. Select **Next** to confirm and proceed to the next step.
OR
Select **Back** to return to the previous step or select **Cancel** to stop the installation.
9. When the Custom Install option is selected:
 - a. Check the required options for the applications to be installed. You may choose to install **Client app files** only, **Server app files** only, or both.

Note

When installing a remote client, install the Client app files only.

- b. Select **Next** to install the selected applications.
OR
Select **Back** to return to the previous step or **Cancel** to stop the installation.

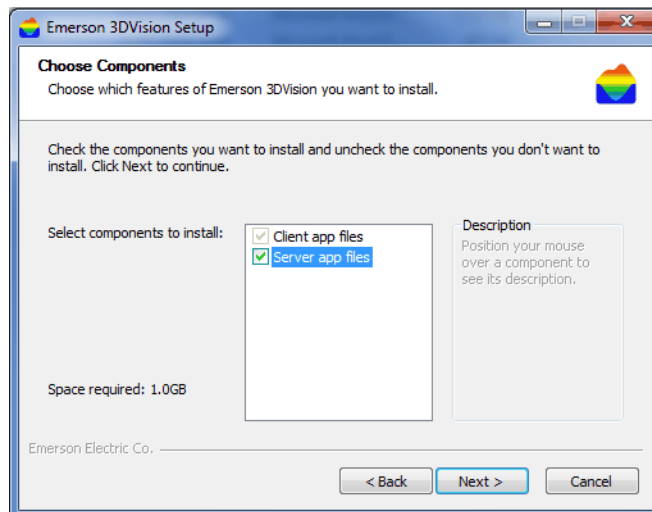

- c. If **Server app files** check-box was previously checked, select the installation method for the Rosemount 3DVision Server. The Server can be installed either as an **Application** (Process) or as a **Service**.

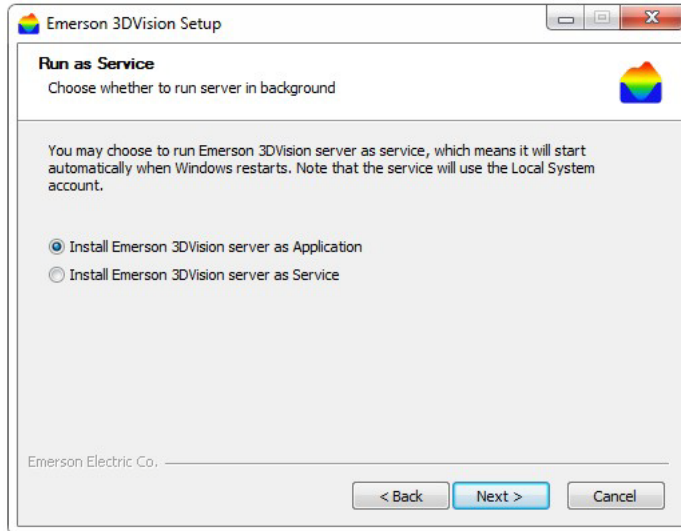

Note

When installing the Server as a Service, the server starts automatically when the OS starts and does not require the user to log in.

- d. Select **Next** to choose the installation folder.
OR
Select **Back** to return to the previous step or **Cancel** to stop the installation.
- e. To change the default installation folder (if required), select **Browse** and specify the desired location for the installation.

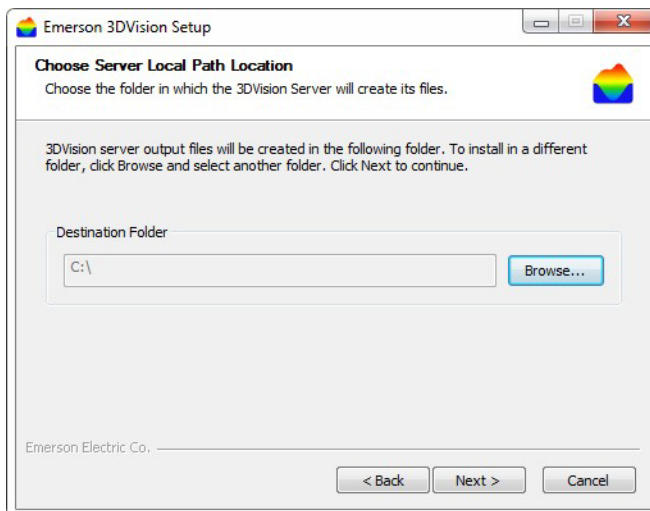

f. Select **Next** to proceed with the installation.

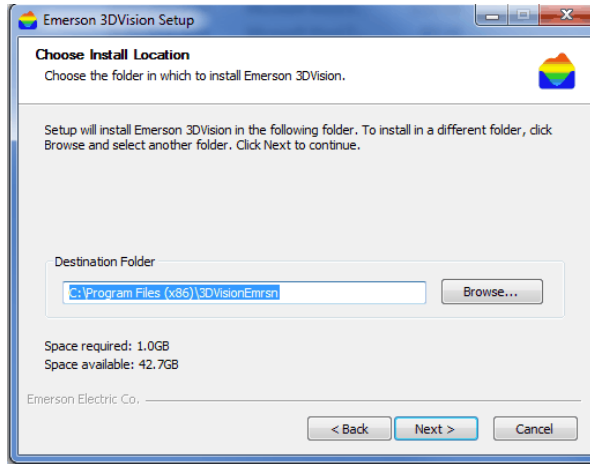

10. Select the *Windows Start Menu folder* where you want the program's shortcuts to be added in the **Choose Start Menu Folder** window. You can also enter a name to create a new folder.

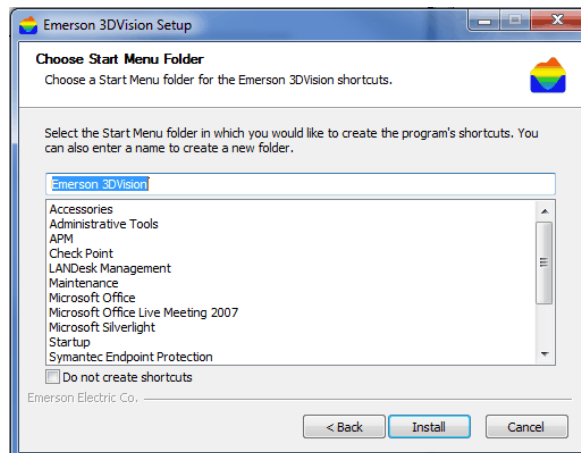

11. Select **Install** to proceed to install the software. Select **Back** to return to the previous step or **Cancel** to stop the installation.

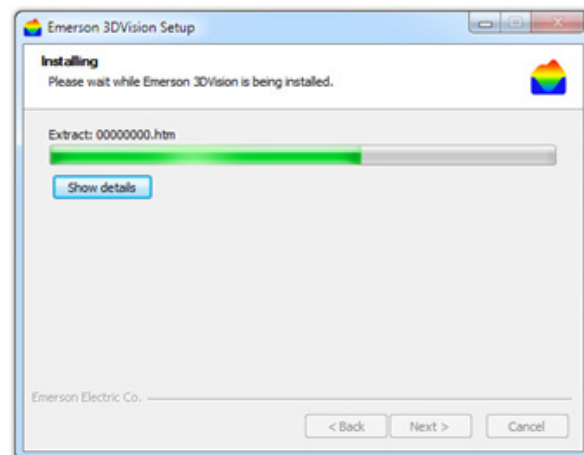

12. Select **Finish** to complete the installation and close the setup wizard.

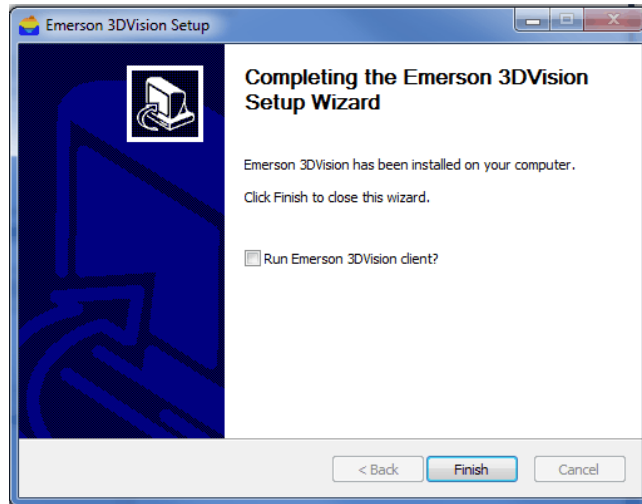

Following a successful installation, the installation package creates a desktop shortcut in accordance with the applications installed (Rosemount 3D Vision Server, Client, or both). A shortcut is also placed in the Startup folder in Program Files.

7.2.3 Starting Rosemount 3D Vision Server and Client

When executing the Rosemount 3D Vision Client for the first time, the system asks for details required to establish a connection to the Rosemount 3D Vision Server. Following a successful connection, a new window appears to enter a user name and password. The default user level is Administrator, with the default user name: admin and password: admin.

1. Double-click the "Rosemount 3D Vision Client" icon to start the client application.



The application opens and the *Rosemount 3D Vision Server Connection* window appears. On the first connection attempt, the Server Name and Server Address fields are empty and the relevant details must be entered. The connection information is kept for subsequent connections.

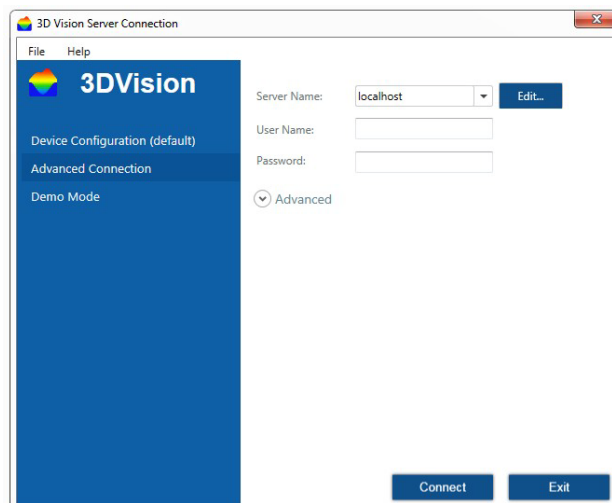

- a. In the *Server Name* field, enter your own description for the system managed by that server.

To activate the *Server Name* field, select **Edit...** Then the *Server Configuration* window appears.

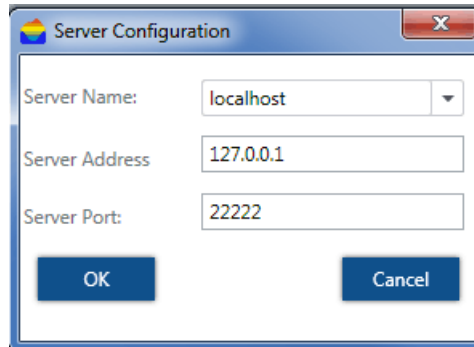

- b. In the *Server Address* field, enter the IP address of the computer running the Rosemount 3D Vision Server:
- If both client and server applications are installed and running on the same computer, enter the computer local IP address, or type IP 127.0.0.1 or type "localhost".
 - If the client application is running on a remote computer, enter the IP address of the computer running the Rosemount 3D Vision Server application.
- c. In the *Server Port* field, verify that the server port is set to 22222.
- d. Select **OK**.
- e. Select **Stay Signed In** to automatically sign in on the next execution of the Rosemount 3D Vision Client application.
- f. Select **Slow Connection** to increase timers and timeouts of various commands in case of slow communication between the Rosemount 3D Vision Server and the Rosemount 5708.
- g. Select the **Auto Reconnection after** option to allow the Rosemount 3D Vision Client to automatically reconnect (with a delay of 20 seconds) to the Rosemount 3D Vision Server.

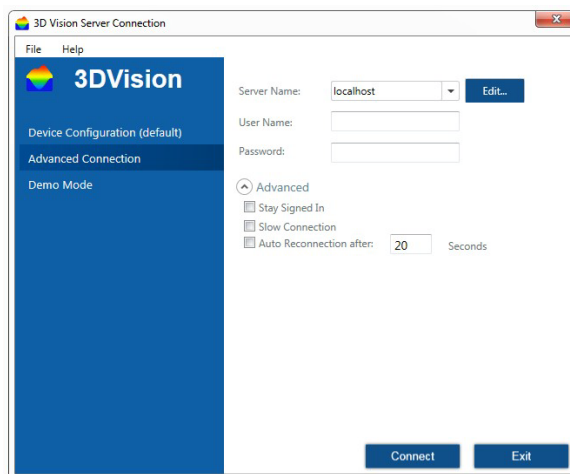

- h. Select **Connect**. The application connects and the Login dialog box appears.
2. Enter User Name and Password. The default username and password are both "admin" (case sensitive).

Note

It is possible to sign out from the File menu under: **File > Exit**.

3. Define the user names, passwords, and permission levels of the various user accounts prior to setting up projects in the system. At least one user account must have the administrator permission level. For further details, refer to “Users Management...” on page 74.

Note

To log in to the technician mode of the system, enter the technician mode user name and password. For further details, refer to “Switch User...” on page 74.

4. The server application may need some time to initialize communications with the Rosemount 5708 and clients. Ensure the server icon appears on the task bar as shown.



The server should remain running. Manually running the server is required only if the computer is restarted and the server does not start automatically.

When installing the server, it is added to the Microsoft Windows Start Up files automatically.

7.3 First-time running

The following steps are required to set a single vessel:

1. Creating a new project (see [page 54](#)).
2. Vessel configuration (see [page 58](#)).
3. Advanced parameters (see [page 62](#)).
4. Echo curve analysis (see [page 62](#)).
5. False echo mapping (see [page 62](#)).
6. Vessel properties configuration (see [page 62](#)).

These steps are basic and mandatory for the completion of a vessel commissioning.

For additional changes and modifications of the vessel and for the Rosemount 3DVision Software, refer to the various software menus starting on [page 66](#).

7.3.1 Creating a new project

Following a successful login, the software automatically opens the last project. If no project exists, create a new project by selecting the **New Project** icon in the center of the screen or by selecting **File > New...** or by importing a saved project by selecting **File > Import Project to Server...**

Figure 7-5. New and Open Project Buttons



To create a new project:

1. Select **New Project**. The *Wizard* window appears.
2. In the *Name* field, enter a name for the new project.
3. In the *# Sites* field, enter the number of sites the project should manage (each site may contain multiple vessels).

Figure 7-6. Project Wizard - Site Name

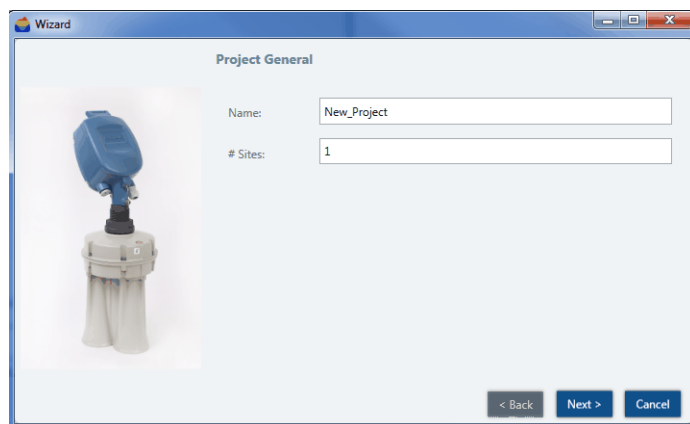

4. Select **Next**.

Note

If you are running the Rosemount 3DVision application you can specify one site and one vessel only. An upgrade to the Rosemount 3DMultiVision version is required for configuring more than one site. Contact your local Emerson™ representative for purchasing a license key for upgrading to Rosemount 3DMultiVision.

5. Enter the site name (limited to 16 characters), number of vessels in the site, and number of Rosemount 5708 in each vessel. Sites, vessels, and Rosemount 5708 can be edited later.
6. Select the connection type between the computer and the Rosemount 5708 in the site.

RS-485, TCP/IP, GPRS and GPRS+SMS connections are available. The very basic connection method is RS-485. For further information on the connection methods, refer to [“Communication methods” on page 91](#).

7. Select the serial COM port for the server PC connection.

Figure 7-7. Project Wizard - Site Connection

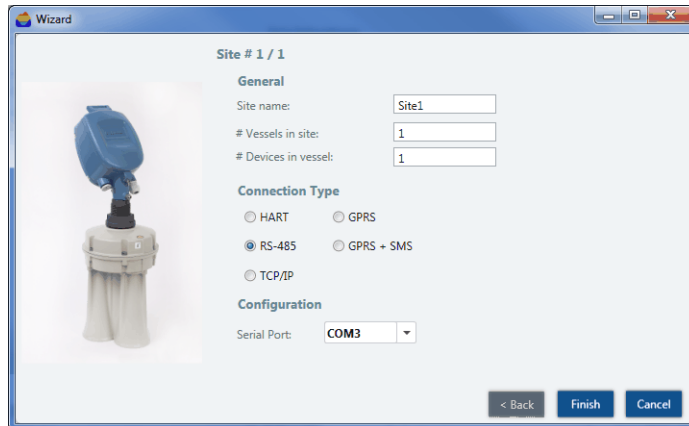

8. Select **Finish**.

The new project is created and the vessels and sites appear on the main screen (Figure 7-8).

Note

When a project includes more than a single site, each site should be defined individually with the number of vessels, the number of Rosemount 5708 units in each vessel, connection method, and serial COM port. Selecting **Next** switches to the next site. Repeat site configurations for each site. In the following example, a single site is defined.

Note

It is possible to change at any time the communication method, switch user to technician, select the device from the device selection drop-list appear above the 3D visualization (see Figure 7-15 on page 63), and go to the parameters tab, disconnect the Rosemount 5708 and set the new communication method and parameters. Select **Save** to save the project.

The project window is built according to the project hierarchy of **Sites > Vessels > Scanners**.

Figure 7-8. Project Window

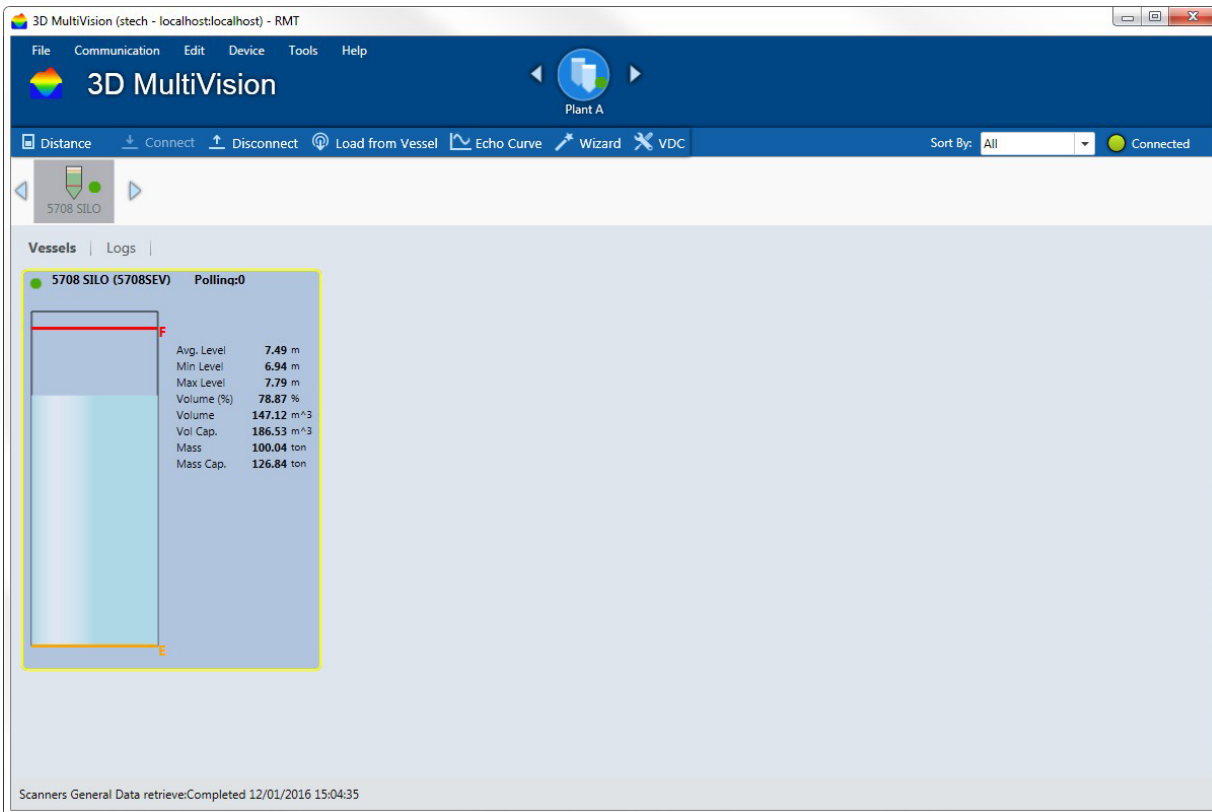

Multiple sites of the project may be defined. The defined sites appear and can be selected from the site selection bar.

When selecting a site, its relevant information and configuration options appear in the main work area organized in two tabs: Vessels and Logs. Refer to “Main screen” on page 66 for display area descriptions.

Multiple vessels may be defined for each site. The vessels are represented by icons appearing on the vessel selection bar. When a site is selected, the corresponding vessels are displayed in the vessel selection bar.

Selecting a vessel from the vessel selection bar displays various types of information and configuration options related to that vessel in the main work area. This information is organized in tabs: Overview, Logs, and Parameters. Right-clicking a vessel icon opens a menu with options related to that vessel.

Multiple devices may be defined under each vessel. A device can be selected and accessed from the device selection list (refer to “Main screen” on page 66).

Note

Selecting a Rosemount 5708 for configuration under a specific vessel can be done only by logging in as a user with Technician or Senior Technician privileges.

Refer to “Users Management...” on page 74 for further details regarding user levels and authorizations.

7.3.2 Vessel configuration

Following successful connection, it is required to configure the devices according to the physical installation and with information of the vessel's dimensions and Rosemount 5708 mounting position.

The wizard is a 4-step procedure to configure the Rosemount 5708 to start working in the application installed, during the Configuration Wizard's steps, there is a 3D visualization of the vessel representing the actions in each step.

To configure the vessel and devices

1. Select the vessel from the vessel selection bar (refer to “[Main screen](#)” on page 66).
2. On the *Device* menu, select **Device Configuration Wizard....** The Configuration Wizards opens ([Figure 7-9](#) on page 59).
3. Set the **Measurement Units** in use for **Distance** and for **Temperature**.
4. Select the proper shape for the vessel top from the **Top Shape** field. The options are: Flat, Cone, Dome, or Pyramid. Set the dimensions:
 - For a Cone shape, set the height and the top diameter of the cone.
 - For a Dome shape, set the height of the dome.
 - For a Pyramid shape, set the top section height, width and length of the vessel top at the X and Y directions.
5. Select the proper shape for the vessel center from the **Center Shape** field. The options are: Cylinder or Cube or cylinder sector. Set the dimensions:
 - For a cylinder shape, set the height and the diameter.
 - For a cubic shape, set the height, width and length of the vessel according to the X and Y axis, respectively.
 - For a cylinder sector, set both bottom and top shapes to flat, set the internal and external diameters, the sector angle (from 15 and up to 90 degrees) and set the sector height.
6. Select the proper shape for the vessel bottom section from the **Bottom Shape** field. The options are: Flat, Cone, Dome, Pyramid or Inverted Cone. Set the dimensions:
 - For a Cone shape, set the height and the bottom diameter of the bottom section.
 - For a Dome shape, set the dome height.
 - For a pyramid shape, set the height, width and length of the vessel bottom section at the X and Y directions.

If the vessel shape is asymmetrical (for both cone and pyramid shapes), it is possible to set the bottom center as an offset from the entire shape center. The X Position and Y Position are the offset of the bottom section from the center.

For Inverted cone, set the height, bottom diameter and top diameter. The inverted cone can be configured only inside the center shape and only when it is set as a cylinder. Top diameter must be smaller than bottom diameter.

The 3D visualization in this step shows the complete vessel. When setting one of the shapes, the 3D visualization will highlight the shape in red to indicate the part being configured at that moment.

7. Select **Next**.

Figure 7-9. Configuration Wizard Step 1 - Vessel Dimensions

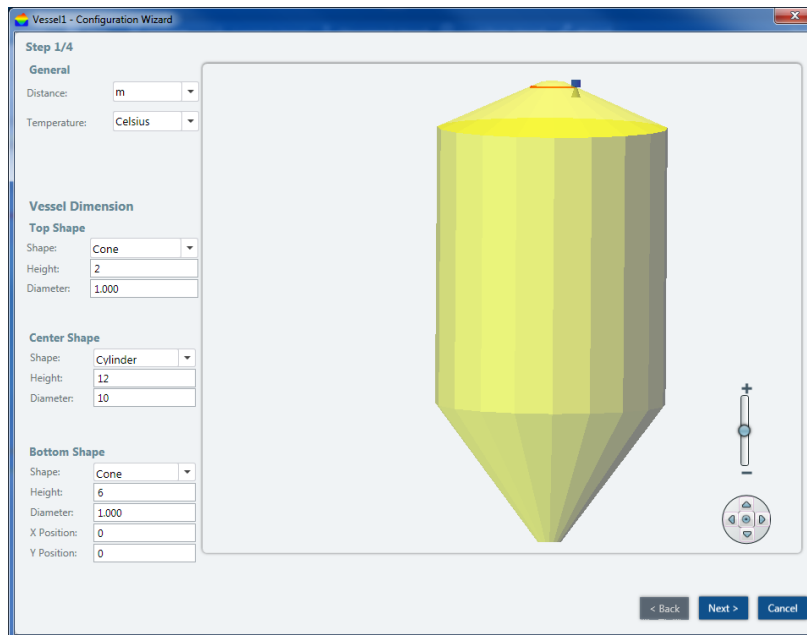

8. Set the Rosemount 5708 position on the silo top.

It is possible to set X and Y coordinates measured from the center of the vessel and set the offset of the Rosemount 5708 from the top of the vessel at the mounting position.

Z position is calculated automatically when the X and Y coordinates modified or there is a change to the offset from the top.

The angle is being calculated automatically when the X, Y coordinates changes, When Senior Technician user is logged in, there is an option to modify the angle manually by checking the **Set device angle manually**.

When entering this step, the 3D visualization is showing the silo from the top and indicating the Rosemount 5708 in the vessel and showing a red arrow indicating the direction of the device that should match the physical installation.

Figure 7-10. Configuration Wizard Step 2 - Rosemount 5708 Positioning

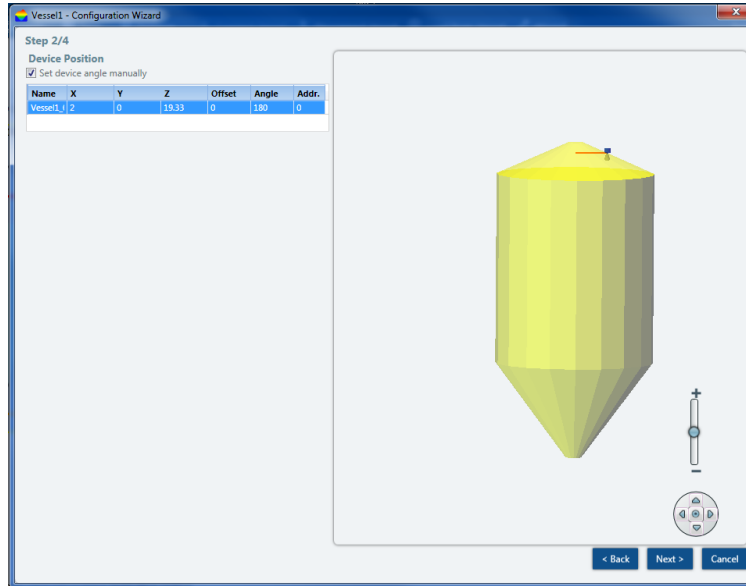

9. Select **Next**.

10. Add the filling points on the top of the vessel. Up to nine filling points may be defined.

- Select **Add** and enter the X and Y coordinates in the **Filling Points** table and press **Enter** after every number entered. Filling points are marked as an inverted orange cone at the set position.
- Select **Delete** to remove the selected filling point.
- Select **Clear** to remove all filling points.

Figure 7-11. Configuration Wizard Step 3 - Device Position

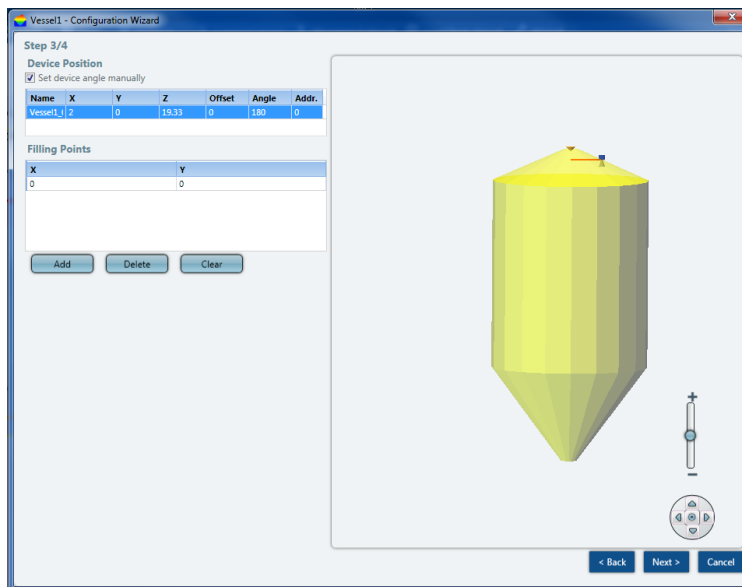

11. Select **Next**.

12. Configure the vessel full and empty calibration levels. [Figure 7-12](#) shows the full and empty calibration fields to set. It is possible to set the full and empty calibration as measured from the top (Distance) of the vessel or measured from the bottom (Level) of the vessel.
 - Set the distance from the top of the vessel to set 100% (20 mA) (see [Figure 7-12 on page 61](#)) in the **Full Calibration** section.
OR
Set the maximal material level in the Level (Bottom) field. Dead band is 1.64 ft (0.5 m) from the top of the Rosemount 5708 antenna case.
 - Set the **Empty Calibration** by setting the level or the distance from the top of the vessel to set the 0% (4mA) (see [Figure 7-12](#)). Default value is set to the bottom of the vessel.
 - Select the **Default** button to set the full and empty calibration levels to default values.
 - Select **View Table** to open a window showing a summary table of each Rosemount 5708 in the vessel and the actual full and empty calibration levels configured, see [Figure 7-13 on page 61](#).
13. Select **Finish**.

Figure 7-12. Configuration Wizard Step 4 - Full and Empty Calibration Levels

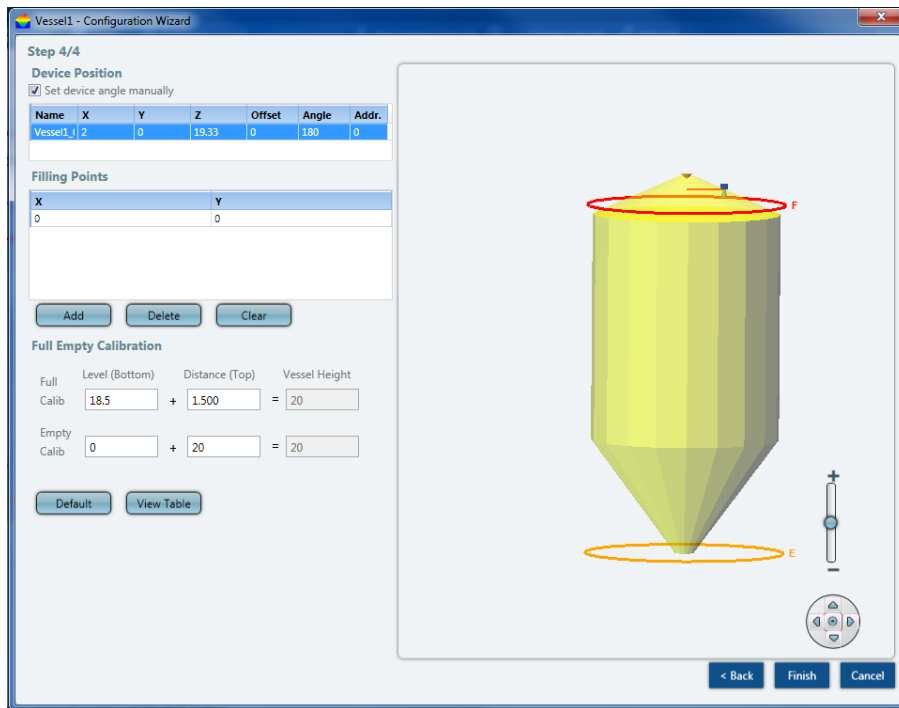

Figure 7-13. Full and Empty Calibration Levels Summary Table

Calib. Type	Scanner Name	Distance from Vessel Top	Level from Vessel Bottom	Distance from Top Scanner	Scanner parameter
Full Calib.	Vessel1_0	0.50	19.50	0.50	0.50
Empty Calib.	Vessel1_0	20	0	20	20

14. When the configuration wizard settings are completed, select the **Finish** button. The parameters will be uploaded to all devices in the vessel.

7.3.3 Advanced parameters

It is recommended to adjust some of the advanced parameters.

Open the advanced parameter window (select **Device > Advanced Parameters...** or press **F3**) in order to set general parameters, such as Max Capacity, Filling and Emptying Rates, Material Slope and Damping Time. Other parameters may be configured and fine adjustments can be done at a later stage. Refer to “Advanced parameters” on page 96 for detailed instructions and descriptions.

7.3.4 Echo curve analysis

When first configuring the vessel, it is recommended to perform Echo Curve Analysis, see chapter “Performing Echo Curve Analysis” on page 109.

View the Echo Curve Analysis results in echo curve viewer. For additional information, see chapter “Viewing Echo Curve Analysis” on page 110.

Using the Echo Curve Analysis it is possible to determine if any of the advanced parameters need additional changes.

7.3.5 False echo mapping

Using the Echo Curve Analysis result, it is possible to determine if false echo mapping actions are needed. For additional information see “False Echo Mapping” on page 112.

7.3.6 Vessel properties configuration

The example below shows how to configure a single site with a single vessel and two Rosemount 5708S.

Note

In order to configure a vessel with more than one Rosemount 5708, all devices must have the same model number (e.g. Rosemount 5708S). Contact your local Emerson representative to purchase a license key for upgrading options.

To configure vessel properties:

1. Select the vessel from the vessel selection bar (refer to “Main screen” on page 66).
2. Right-click the vessel and select **Property...** from the drop-down menu. The *Edit Base Properties* window opens (Figure 7-14).
3. Enter the vessel name and description. Select **OK**.

Figure 7-14. Edit Base Properties Window

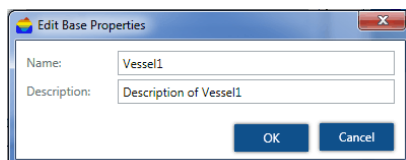

4. Double-click the vessel in the vessel selection bar to open the vessel measurements and details in the main work area (Figure 7-15). The **Overview** tab shows how many devices are set for this vessel and their connection status.

Note

If the selected vessel contains more than one device and the user has technician privileges, a device selection list appears (see Figure 7-15). Select the required device for configuration from the list.

Figure 7-15. Rosemount 3DMultiVision Vessel Overview Tab

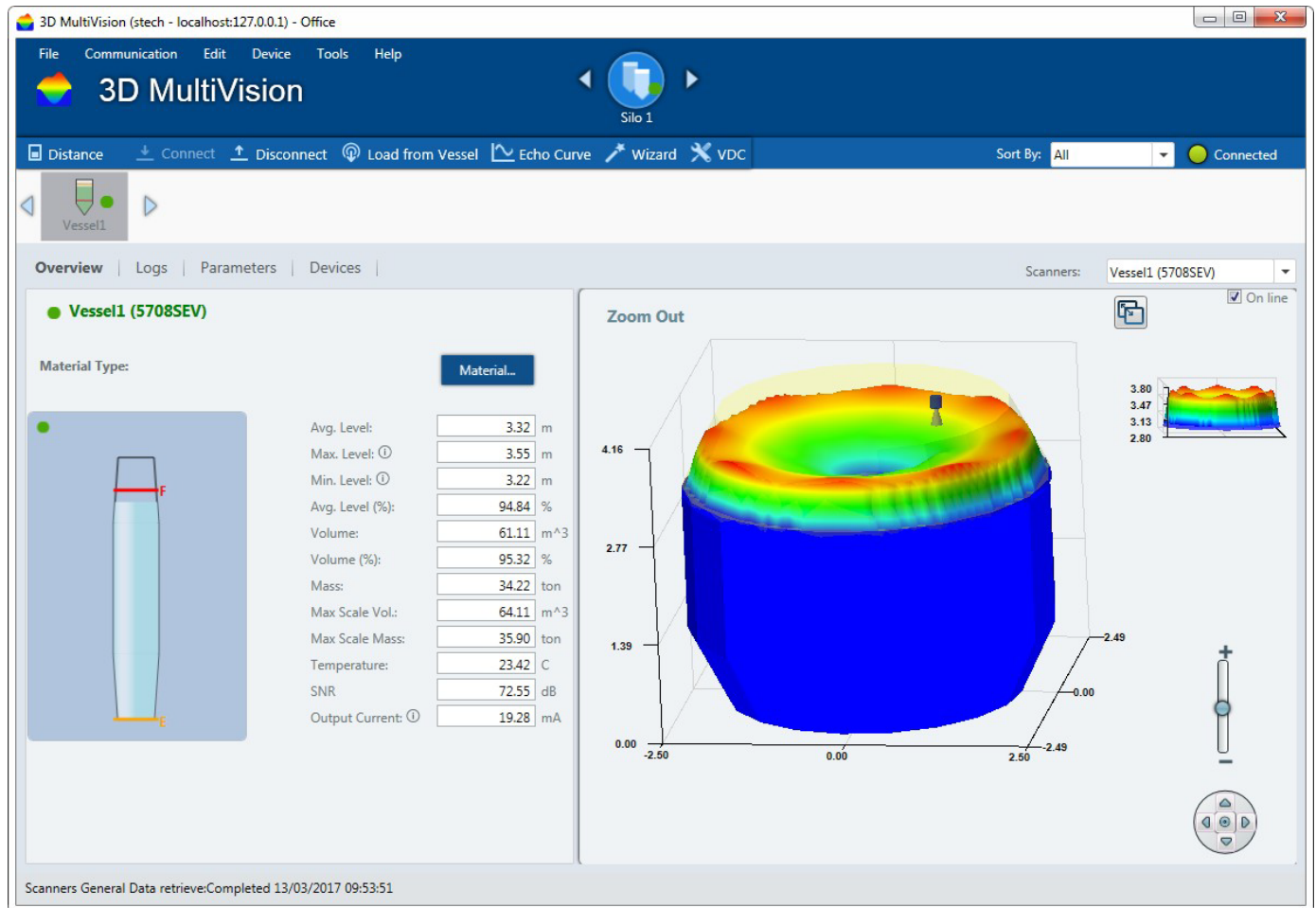

5. Select the **Parameters** tab to configure the Rosemount 5708 parameters (Figure 7-16 on page 64).

Note

Rosemount 5708 parameters can be modified only in technician mode. For further information on the connection methods, refer to "Communication methods" on page 91.

Figure 7-16. Rosemount 5708 Parameters Tab

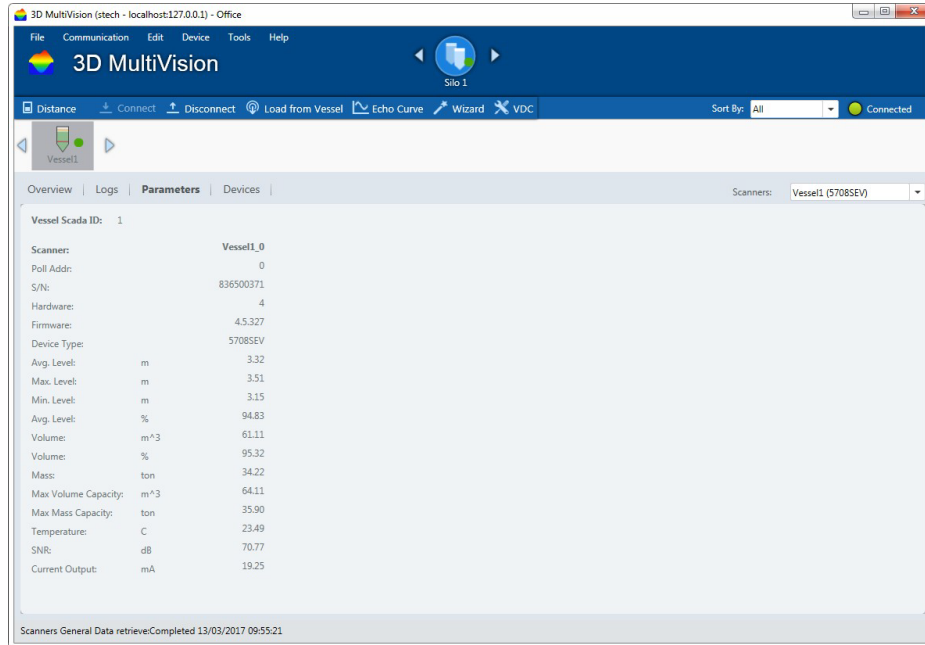

6. Select the **Devices** tab to set connection type, serial COM port, and polling address.

Figure 7-17. Rosemount 3DMultiVision Vessel Devices Tab

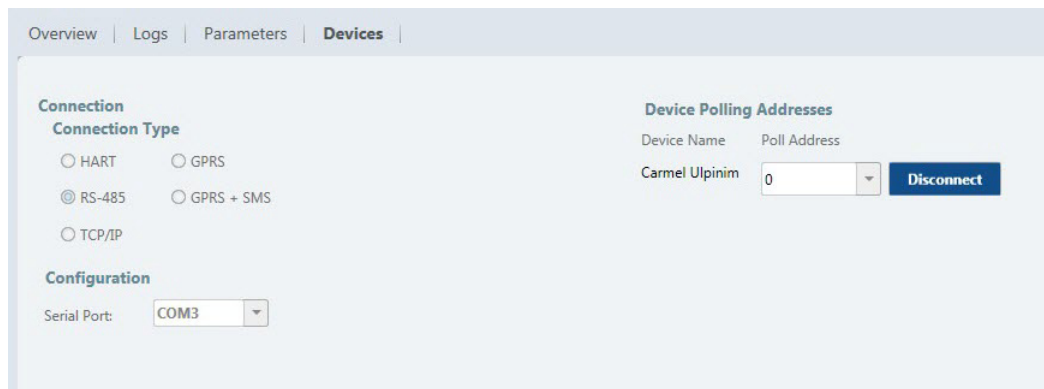

7. Set Connection Type (the unsupported types are visible but not selectable).

Note

Connection type is enabled for editing only when the Rosemount 5708 is disconnected.

For further information on the connection methods, refer to “Communication methods” on page 91.

8. Set Serial COM Port.
9. Set Polling Addresses.

10. Configure each Rosemount 5708 set for the vessel by selecting them from the device selection list and entering their communication parameters.
11. Once all devices are configured, connect to all the devices in the vessel by right-clicking the vessel name and selecting the **Connect** option from the drop-down menu.
12. When a connection is established, select the site from the site selection bar (as shown to the right). The vessel profile screen appears with the results of the scanned measurements.



13. To view a 3-dimensional profile, right-click on a vessel in the main work area and select Show 3D visualization from the drop-down menu. The profile window opens (Figure 7-18).

Figure 7-18. Product 3-Dimensional Profile

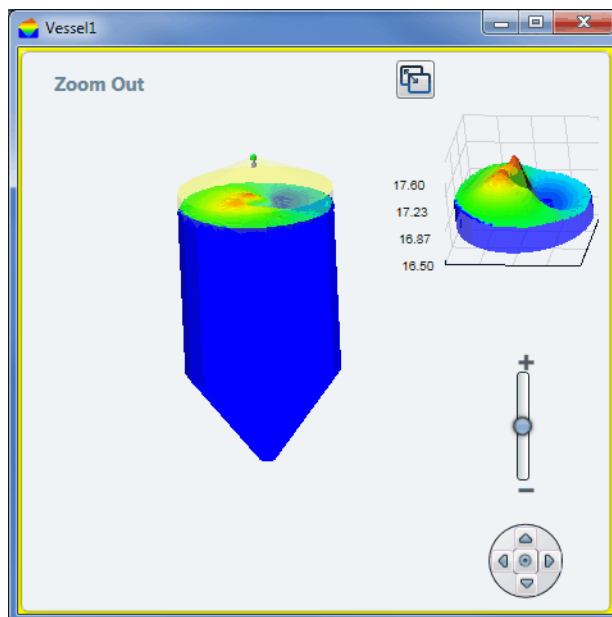

Note

When connecting to the Rosemount 5708S, the 3D visualization of the product in the vessel is available by double-clicking the vessel.

For further information on the 3D visualization, refer to “3D visualization” on page 128.

7.4 Software navigation

This chapter provides an overview of the various toolbars, menus, and projects.

7.4.1 Project overview

The Rosemount 3DMultiVision software allows for defining different projects. Each project is organized in the following hierarchical structure:

- Top Level: The project
- Second Level: A list of sites
- Third Level: A list of vessels located in the site
- Fourth Level: A list of devices associated with each vessel

For example, a single project may include multiple sites (or multiple groups of vessels), where each site/group may contain multiple vessels, with a minimum of one Rosemount 5708 per vessel.

7.4.2 Main screen

Figure 7-19 displays the main screen areas followed by their descriptions.

Figure 7-19. Main Screen

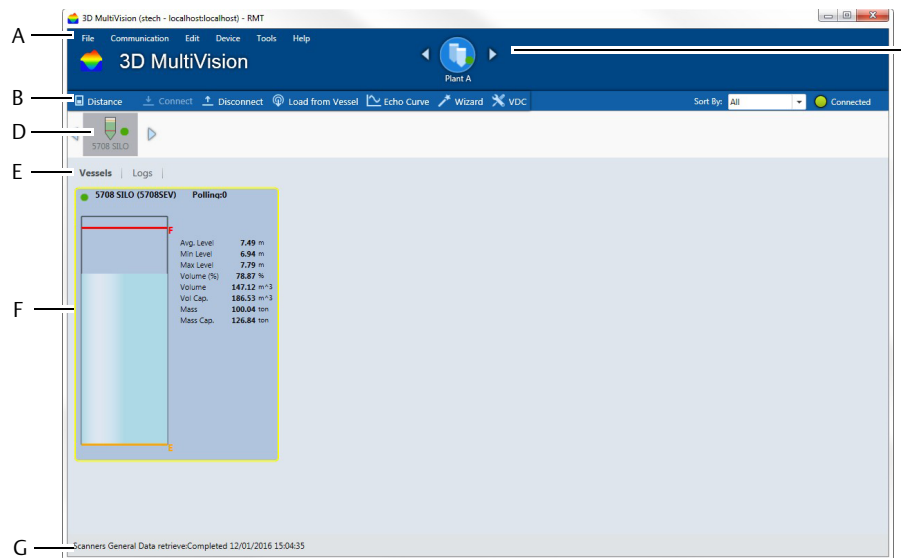

- Main menu bar:** Includes the main menus: File, Communication, Edit, Device, View, Tools, and Help.
- Project toolbar:** Includes various tools for project management and operations including project opening and saving, connection to sites, and data loading.
- Site selection bar:** A project allows multi-site management, where each site may include multiple vessels. In the site selection bar, a site can be selected for monitoring and operations.
- Vessel selection bar:** Lists all vessels included in the selected site. In the vessel selection bar, a vessel can be selected for monitoring and various operations.
- Control tabs:** Includes tabs related to the selected item (site, vessel, or Rosemount 5708). Each selected tab is displayed in the main work area.
- Main work area:** Provides graphical and textual information and properties, and different modification and control options related to the selected item (site, vessel, or Rosemount 5708) and tab.
- Status bar:** Displays actual information related to different operations performed, such as downloading data and connection.

7.4.3 Main menu bar

The Rosemount 3DVision Client main menu bar accesses the main menu options.

Figure 7-20. Main Menu Bar

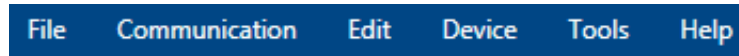

File menu

The File menu includes the following options:

Figure 7-21. File Menu

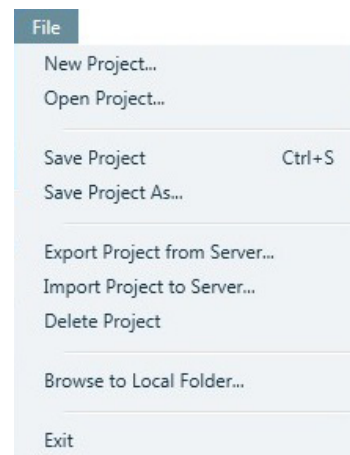

Table 7-1. File Menu

Option	Description
New...	Starts a new, empty project.
Open...	Opens an existing project.
Save Project	Saves the current project.
Save Project As...	Saves current project as a different name.
Export Project from Server...	Exports a project in XML format.
Import Project to Server...	Imports a project in XML format.
Delete Project	Deletes a project from the server. A window opens with a list of all projects stored in the server and the desired project is selected.
Browse to Local Folder...	Allows browsing the software installation folder.
Exit	Closes the application.

Note

The Import and Export functions are for maintenance. They enable downloading projects to a local computer for modifications and Software upgrades, and then uploading the modified projects back to the server.

Note

Projects can only be deleted if there is at least one project remaining. The current project cannot be deleted.

Communication menu

The available options in the Communication menu change in accordance with the selected item. If a vessel is selected, it corresponds to a vessel connection. If a Rosemount 5708 is selected, it displays Rosemount 5708 related commands, e.g. Connect & Disconnect.

The following options are available when a vessel is selected:

Figure 7-22. Communication Menu

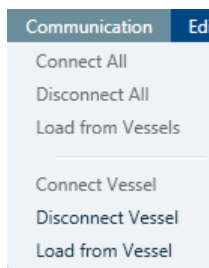

Table 7-2. Communication Menu

Option	Description
Connect All	Connect to all the devices in the selected site.
Disconnect All	Disconnect from all the devices in the selected site.
Load from Vessels	Download all data from all vessels.
Connect Vessel	Connect to all devices in the selected vessel.
Disconnect Vessel	Disconnect all devices in the selected vessel.
Load from Vessel	Download all data from all devices in the selected vessel.

Edit menu

The Edit menu includes the following options:

Figure 7-23. Edit Menu

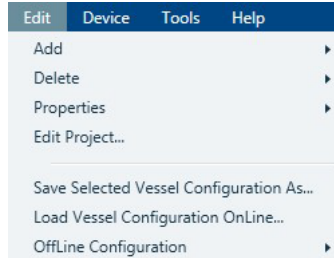

Table 7-3. Edit Menu

Option	Description
Add ►	Add sites, vessels, or devices depending on the level selected in the project pane.
Site	On the site level it adds sites or vessels.
Vessel	On the vessel level it adds devices.
Scanner	On the device level it is disabled.
Delete ►	Delete sites, vessels, or devices depending on the level selected in the project pane.
Site	On the site level it deletes sites.
Vessel	On the vessel level it deletes vessels.
Scanner	On the device level it deletes devices.
Properties ►	Set a name and description to a site or a vessel
Site	On the site level define the name and description of the site.
Vessel	On the vessel level define the name and description of the vessel.
Vessel graphic figures	Additional option (only available when a vessel is selected): Add text labels on the 3D visualization (X, Y, and Z coordinates are referenced to the center axis located at the bottom center of the vessel).
Edit Project...	An interface option to rearrange the vessels and sites per requirements.
Save Selected Vessel Configuration As...	This operation saves the selected vessel configuration into an XML file for maintenance and support issues.
Load Vessel Configuration OnLine...	This operation uploads a saved XML file with the vessel configuration into the project that is running online.
OffLine Configuration ►	When in Offline mode there are options to work on existing project.
Manual Load to Selected Vessel...	This operation loads parameters manually when the software is offline and not connected to devices.
Cancel Manual Load from All Vessels	This operations cancels manual load from all the vessels in the project.
Browse to Vessel AutoSaved File Folder...	This operation opens a window within the folder with all the saved configuration XML files.

Figure 7-24. Edit Project Option

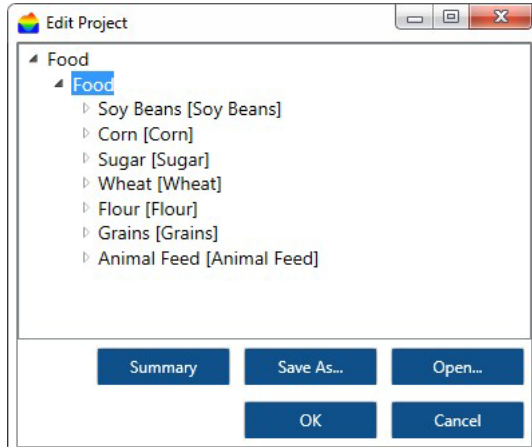

Figure 7-25. Vessel Graphic Figures

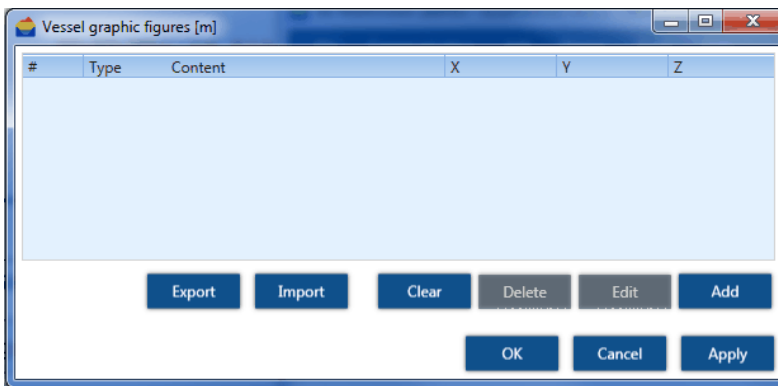
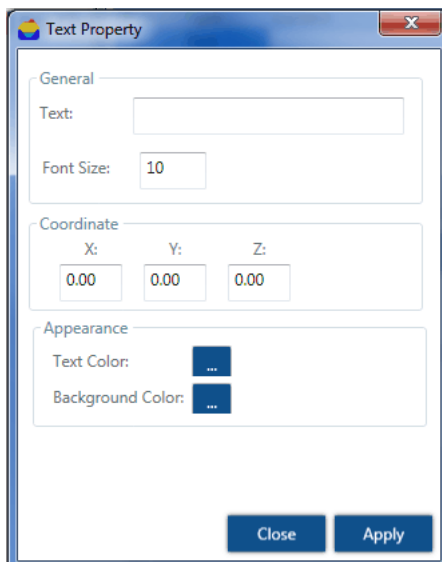

Figure 7-26. Example of Adding a Text Label to the 3D visualization



Device menu

The device menu includes the following options:

Figure 7-27. Device Menu

Device	Tools	Help
Device Configuration Wizard...		F4
Advanced Parameters...		F3
Device Current Simulation Settings...		F6
Device Output Current...		F8
Device Output Settings...		F7
Echo Curve Analysis...		Ctrl+Z
Echo Curve Analyze Viewer...		Ctrl+V
Device False Echo Mapping...		
Devices Activations...		
Update Model...		

Table 7-4. Device Menu

Option	Shortcut	Description
Device Configuration Wizard...	F4	Opens the configuration wizard for the selected vessel, see “Vessel configuration” on page 58.
Advanced Parameters...	F3	For additional info, refer to “Advanced parameters” on page 96.
Device Current Simulation Settings...	F6	For additional info, refer to “Device current simulation settings” on page 101.
Device Output Current...	F8	For additional information, refer to “Device output current” on page 102.
Device Output Settings...	F7	For complete information about all functions under the Output Settings window, refer to “Device output settings” on page 103.
Echo Curve Analysis...	Ctrl+Z	For complete information about all functions under the Output Settings window, refer to “Echo Curve Analysis” on page 109.
Echo Curve Analyze Viewer...	Ctrl+V	For complete information about all functions under the Output Settings window, refer to “Viewing Echo Curve Analysis” on page 110.
Device False Echo Mapping...	N/A	For complete information about all functions under the Output Settings window, refer to “False Echo Mapping” on page 112.
Devices Activations...	N/A	Allows different types of Resets, Update Firmware and to test communication quality. For complete information about all functions under the Output Settings window, refer to “Device activations” on page 114.
Update Model...	N/A	Allows a Rosemount 5708L or 5708V to be upgraded to a Rosemount 5708V or 5708S.

Note

Some of the options allow changes only if the user is a Technician or a Senior Technician. Refer to “Users Management...” on page 74 for additional information. Viewer has no option to do any changes under this menu, Administrator can do only some of the actions.

Tools menu

The Tools menu offers useful tools such as reporting and administration tools, material configuration, Server options, user management and Demo mode.

Figure 7-28. Tools Menu

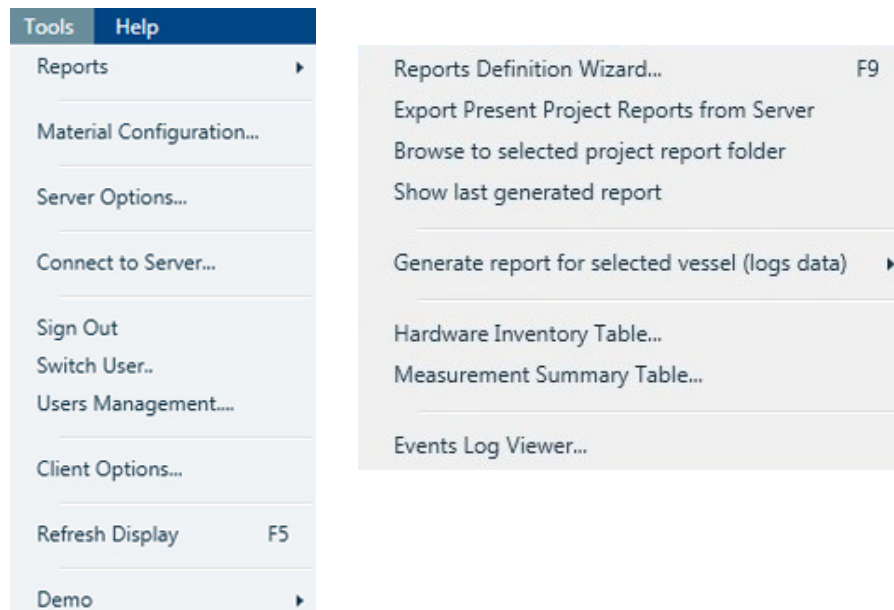



Table 7-5. Tools Menu

Option	Description
Reports ►	Report files are created and stored in Excel worksheet format and can be opened, viewed, and manipulated using Excel. Note To open and view report files in Excel® format, Microsoft Excel must be installed on the computer.
Reports Definition Wizard... (F9)	Opens a wizard to set, edit and generate reports. “Reports Wizard” on page 116.
Export Present Project Reports from Server	Opens a date picker to select the From and To dates for the project reports. Select OK to retrieve the list of corresponding report files from the server (Figure 7-29). Select the required reports from the list. Click Select to browse to a folder to store the selected report.
Browse to selected project report folder	Opens a file browse window in the project report files location on the local hard drive. Available only if the Client is running on the same computer as the server.
Show last generated report	Opens the last generated report in Excel. Available only if the Client is running on the same computer as the server. See Figure 7-29.

Option	Description
Generate report for selected vessel (logs data) 	
Select logs directory from local folder...	Browse to local folder to retrieve saved reports
Download from server	Select time and date of the required information. The generated file is a .pdf and will be saved at a selected location.
Hardware Inventory Table...	Displays a special report including details for all project devices. For more details, refer to “Hardware inventory table” on page 125 .
Measurement Summary Table...	Displays a special report of vessel storage measurements for all project vessels. For more details, refer to “Measurement summary table” on page 125 .
Events Log Viewer...	Displays a list of events tracking of changes in the project,
Material Configuration...	Opens the Material Configuration window for defining new material types and color and for setting bulk density for mass calculation. This data is displayed in the vessel images. For further details, refer to “Material configuration” on page 127 .
Server Options...	<p>Summary: Opens a window with a summary of the server information. See Figure 7-30.</p> <p>Configuration: Allows setting the Server's Local folder to save all files.</p> <p>Active TCP Connections: Retrieves and displays a list of all active TCP connections on Server computer and contains a list of all existing connections to the server. Each connection displayed includes the local port, remote port, TCP/IP address, and status. See Figure 7-31.</p> <p>Active TCP Listeners: Retrieves and displays a list of all existing TCP ports listeners on the server computer. See Figure 7-32.</p> <p>Scada Configuration: Allows SCADA systems to be integrated to the server. Opens a window for activating integration support and specifying up to four TCP listening ports, allowing up to 4 different SCADA systems to retrieve information from the server. The communication type is Modbus RTU encapsulated in TCP/IP packets or Modbus TCP. In addition, a folder path can be set to store a file containing the 3D visualization to be popped up from the SCADA system. See Figure 7-33.</p> <p>License Key: Upgrade from the single-vessel Rosemount 3DVision software license to the Rosemount 3DMultiVision software license by entering a new license key. Also entering license codes for Center of Gravity and Output by Sections activations. For a detailed description, refer to “Upgrading to Rosemount 3DMultiVision” on page 132.</p> <p>Paste the License key you received into the field and select Apply. The Rosemount 3DVision Client title bar switches from Rosemount 3DVision to Rosemount 3DMultiVision, if the key is correct. See Figure 7-35.</p>
Server Options... (Continued)	<p>The Don't remind check-box on Figure 7-34 is for not getting the notification on the top window screen part that there is a remaining X days until the free 30-days trial Rosemount 3DMultiVision license is over.</p> <p>Logged Clients: Shows a list of clients currently connected to the Rosemount 3DVision Server. See Figure 7-35.</p>
Connect to Server...	Connects the client to a server (if not already connected), or disconnects the current connection and connects to a different server. For further details regarding server connection, refer to “First-time running” on page 54 .
Sign Out	Cancel the 'Stay Signed In' option previously selected when the Rosemount 3DVision Client was executed.

Option	Description
Switch User...	<p>Logs out the current user and logs in as a different user. This function opens a window requesting the user name and password.</p> <p>Note Each user account has its own defined permission level. If you switch to a user account with a lower permission level, you will be more limited in the actions you can perform.</p>
Users Management...	<p>Opens the Users dialog box displaying a list of all the user accounts defined on the server and their permission levels. For further details regarding user levels and authorizations, refer to “User management” on page 126. This option is available to users with Administrators privileges. See Figure 7-36.</p> <p>The Users dialog box enables adding, removing, and changing properties of users.</p> <ul style="list-style-type: none"> ■ Users Authorization is Enabled: Un-checking this field will allow opening the Client without the need to enter user name and password. ■ Add: Select to add a new user. A dialog box opens requesting a name, password, and permission level for the new user. ■ Remove: Select the user account you want to delete, and then select Remove. ■ Properties: Select a user from the list and select Properties to change their properties. A dialog box opens enabling the user to change the name, password, and permission level for the selected user. ■ Close: Select to accept the changes and close the Users dialog box.
Client Options...	<p>Site - Vessel: See Figure 7-37.</p> <ul style="list-style-type: none"> ■ Site view manual: Allows multiple vessels in a single display without the need to scroll the window. ■ Vessel width limits: Defines the minimum and maximum width dimensions of the vessel in site view. Measured in pixels. When the window is stretched or reduced, the size of the vessel will change between these values. ■ Vessel height limits: Defines the minimum and maximum heights of the vessel in site view. ■ Group by name/material/site name: Defined in parallel to vessel limit definition, to give full flexibility in different types of layouts and switching between layouts. ■ Reduced vessel display: When reducing the size of window, the vessel size in site view will be smaller up to the limit of minimum size configured in this window. Values on the right side will disappear and only the first in the list will appear above the vessel drawing. ■ Enlarge text area width in vessel display: If checked, it will enlarge the text above the vessel's image. By default, it is not checked and the text above the vessel's view will be small. ■ Enlarge Sites tool bar to maximum: When working with multiple sites, if checked, it will squeeze all the sites in the menu bar as much as possible, else it will give the option to scroll left and right for sites display. ■ Show vessels chart lines according to site: In the vessel's logs tab, all the logs of the vessels in the site (group) that the vessel is related to will be shown. For example, if we have three sites, and in one of the sites we have 7 vessels, selecting this option, all the seven related trends in one log chart will be displayed.

Option	Description
Client Options... (Continued)	<p>Project: See Figure 7-38.</p> <ul style="list-style-type: none"> ■ Auto save project on vessel change: If checked, it will automatically save all changes made to the project. ■ Show save project warning on vessel change: if checked, for every change done in the project, it will give a pop up window to alert the user that a change is planned, and the user must save in order to continue. ■ Logo Image File...: The user can add a (company) logo/image on the top right corner of the Rosemount 3DVision main screen. <p>Change Language: See Figure 7-39. Enables changing the software's language.</p> <p>Server Connection Mode: See Figure 7-40. Enables the user to choose between single server connection or multiple servers connection from a client's Rosemount 3DVision.</p> <p>Translate Application: Allows the user to translate the Rosemount 3DVision to any language and send the translation file to the manufacturer to embed in future versions.</p> <p>Sites/Vessels Filtering: See Figure 7-41. In a complex project with multiple sites and vessels, the software allows an option of viewing a partial set of selected vessels and sites only, per the preference of the user.</p>
Refresh Display (F5)	This option refreshes the screen display in the case of communication problems.
Demo ►	Activates the software in Demo mode. This option includes selecting a demo site, performing a simulated operation of the sites, various components, and creating logs. For further details, refer to “Demo mode” on page 126 .

Figure 7-29. Report Files Selection

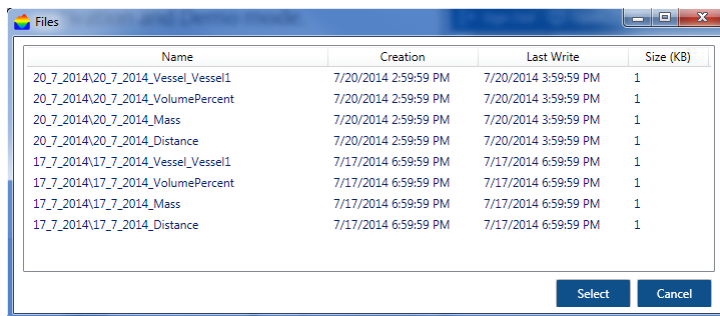

Figure 7-30. Server Options... - Summary

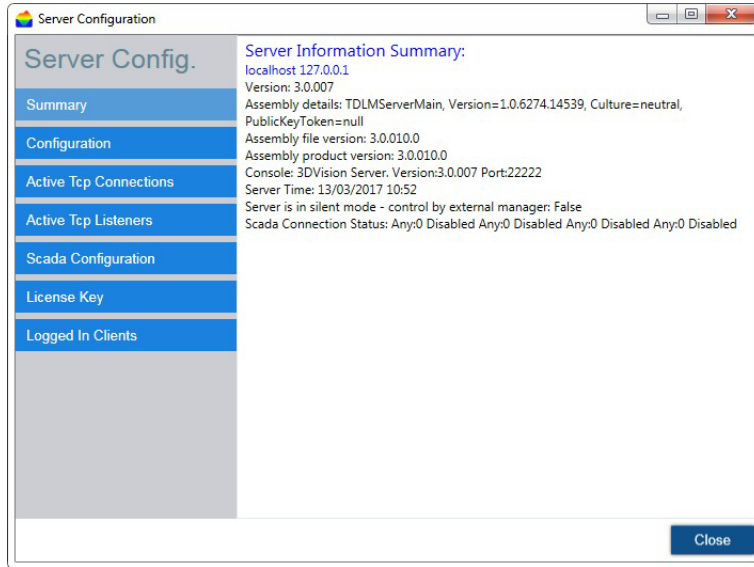

Figure 7-31. Server Options... - Active TCP Connections

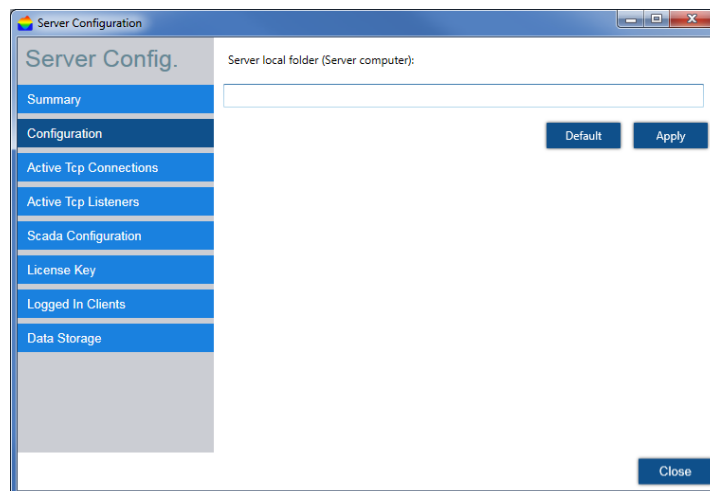
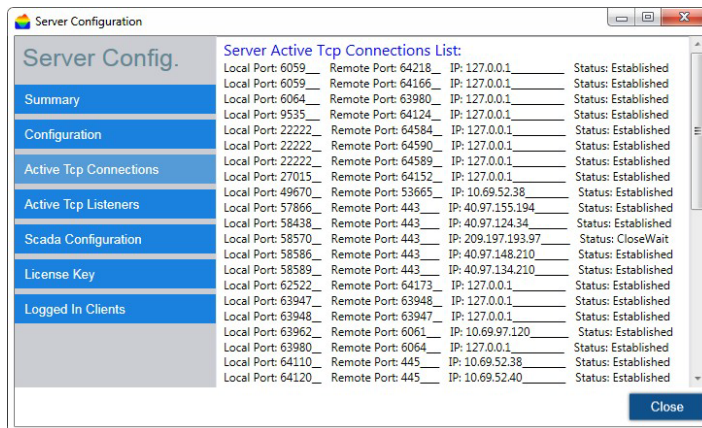

Figure 7-32. Server Options... - Active TCP Listeners

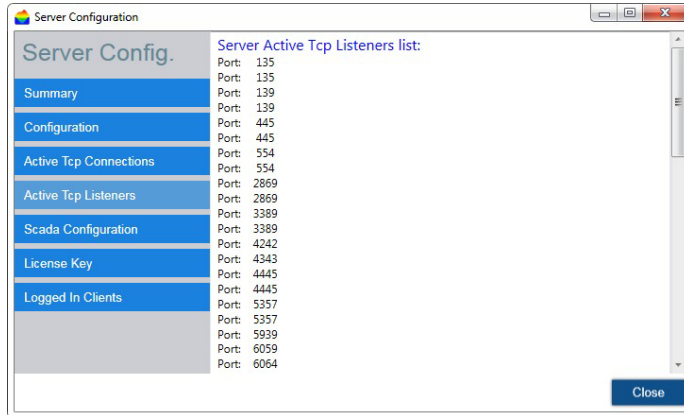

Figure 7-33. Server Options... - Scada Configuration

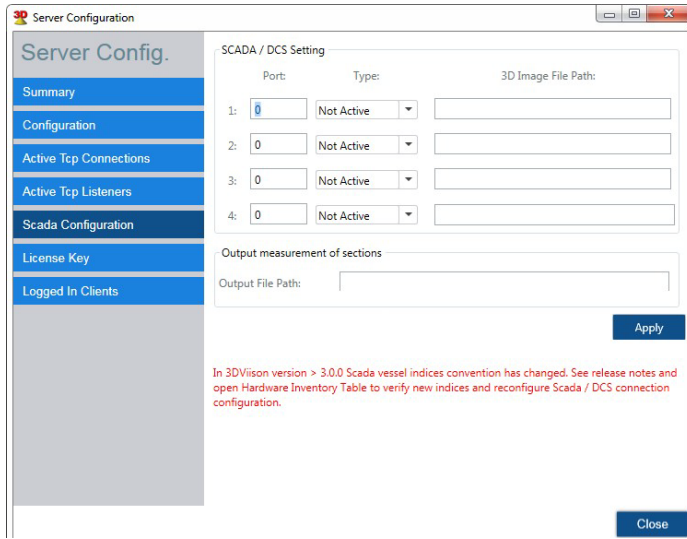

Figure 7-34. Server Options... - License Key

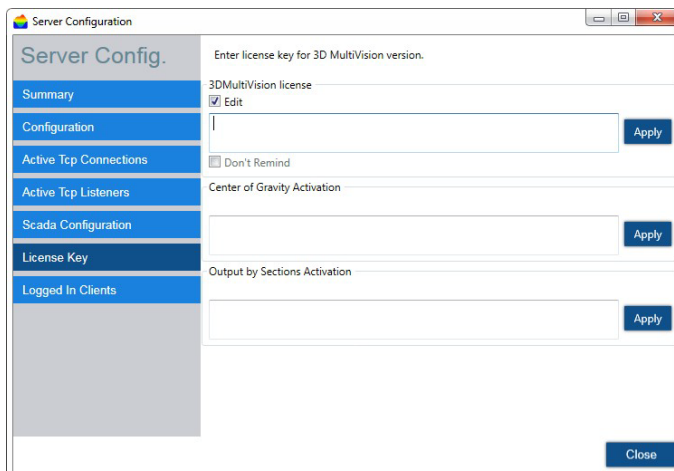

Figure 7-35. Server Options - Logged In Clients

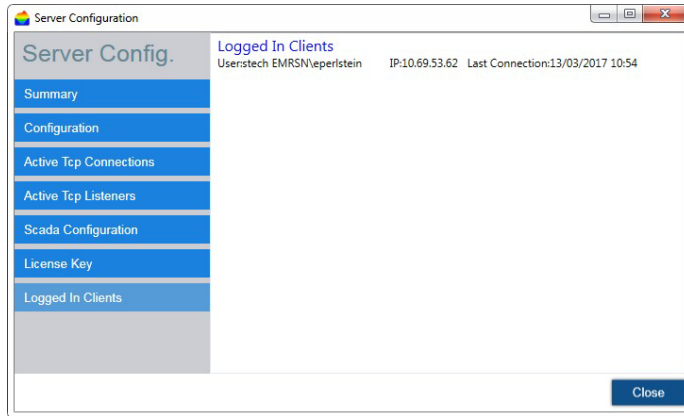

Figure 7-36. Users Management Dialog Box

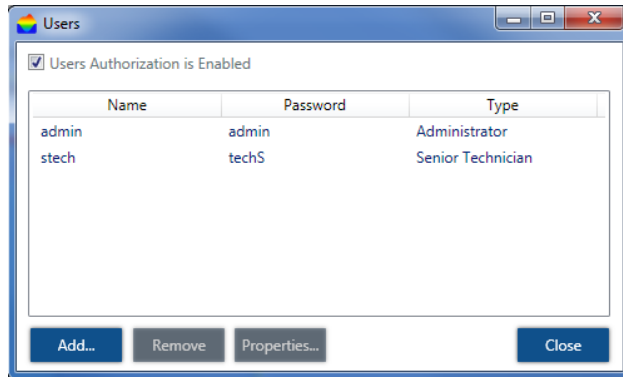

Figure 7-37. Client Configuration Window - Site - Vessel

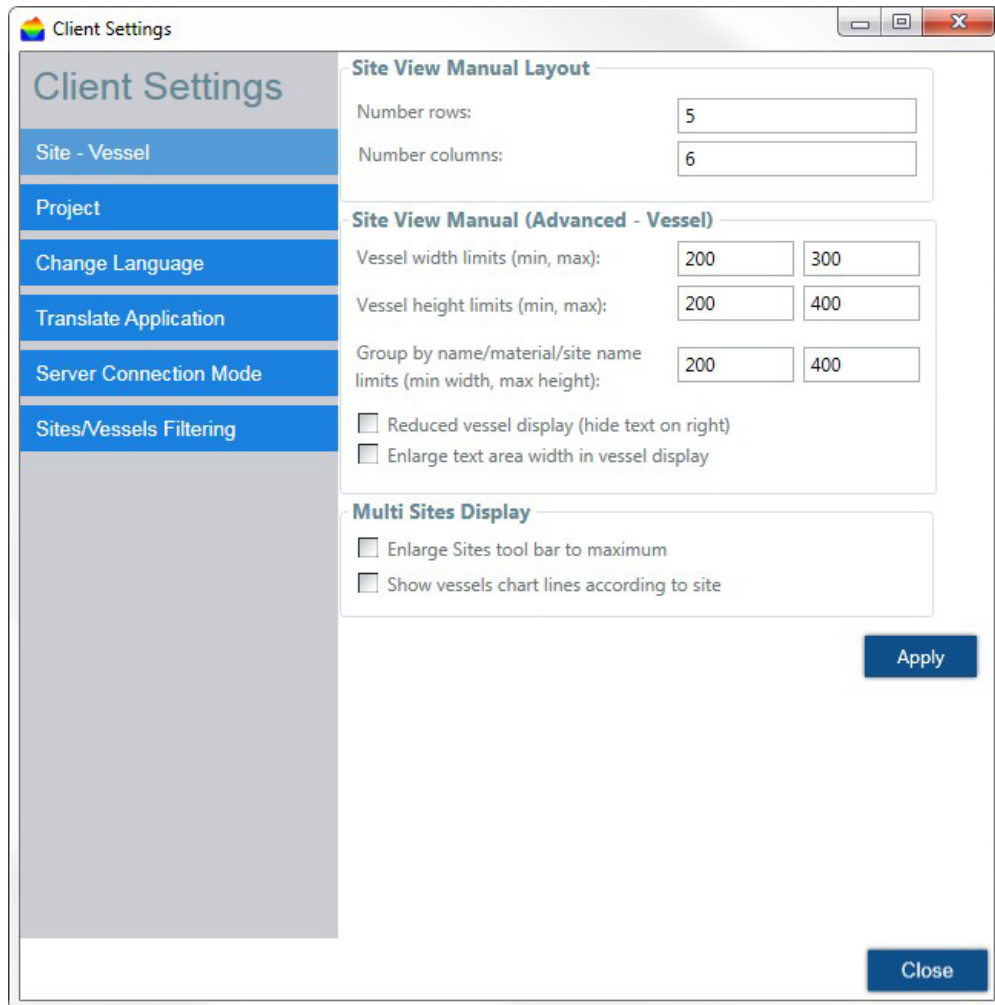

Figure 7-38. Client Configuration - Project

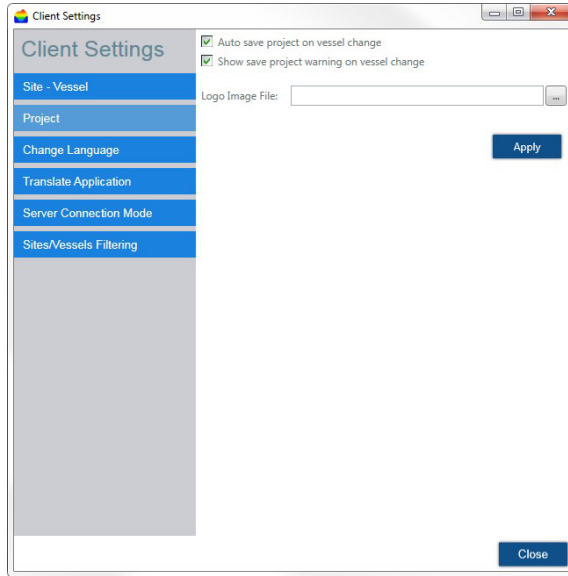

Figure 7-39. Client Configuration - Change Language

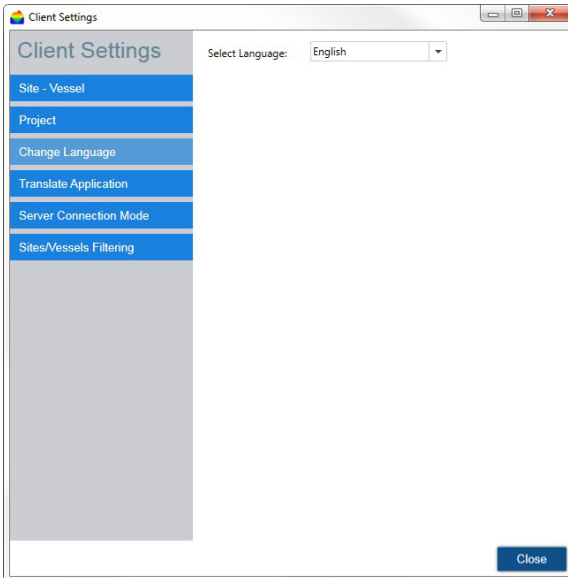

Figure 7-40. Client Configuration - Server Connection Mode

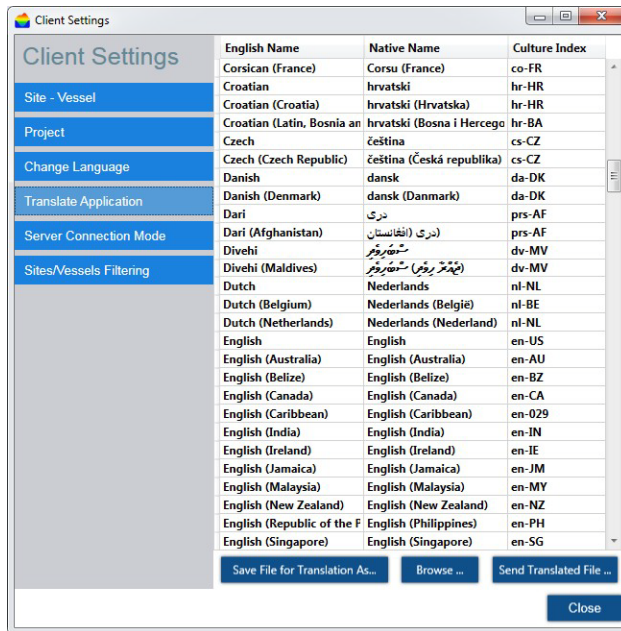
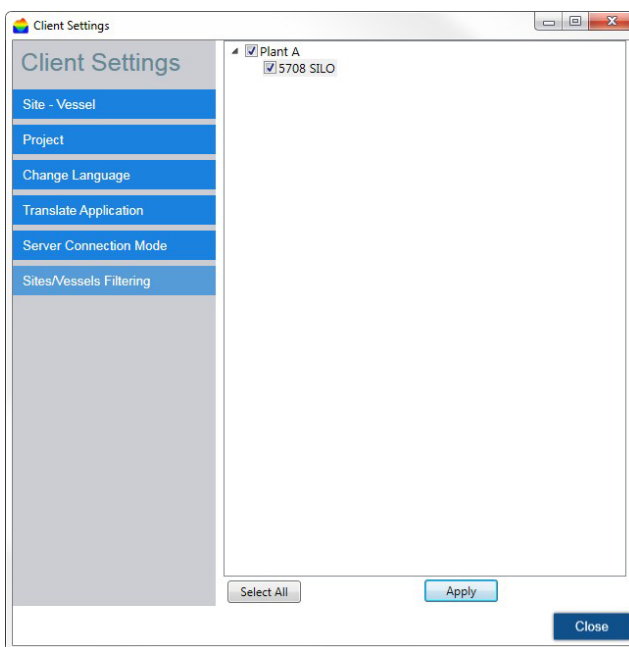

Figure 7-41. Client Options / Sites - Vessels Filtering



Help menu

The Help menu includes a link to the Rosemount 5708 Quick Start Guide and to this reference manual.

The About option opens a window with version details, Emerson support number, and a link to the Emerson website.



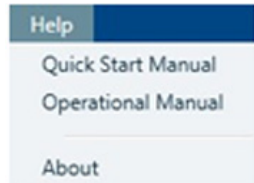



Figure 7-42. Help Menu



7.4.4 Project toolbar

Figure 7-43. Project Toolbar



Function		Description
 Distance	Level/Distance Data	Toggles the measurement type displayed in the vessel by either Level or Distance. Level refers to the level of material measured from the bottom of the silo. Distance refers to the distance of the material from the Rosemount 5708. The selection applies for measurements in all viewing panes, at all view levels, for the corresponding values (min/max/average).
 Connect Vessel	Connect Vessel	Connects the selected Vessel to the application.
 Disconnect Vessel	Disconnect Vessel	Disconnects the selected Vessel from the application.
 Load from Vessel	Load from Vessel	Downloads all measurements from the selected vessel to the application. All data is automatically downloaded from all devices to the server.
 Wizard	Wizard	This button is a shortcut for opening the Wizard.
 Echo Curve	Echo Curve	A shortcut to open the Echo Curve Analysis window, same as clicking Device > Echo Curve Analysis or by clicking Ctrl-Z
 VDC	VDC	Stands for Vessel Data Collector - a tool to help users collect all relevant information from the vessel and to send it to the factory. Need to add another chapter showing the windows and options on the VDC.

<div data-bbox="167 268 440 304" style="border: 1px solid black; padding: 2px;">Sort By: All</div>	<p>Sort By</p>	<p>Organizes the vessels by group.</p> <ul style="list-style-type: none"> ■ All: Arrange by the numbering order as defined in the project. ■ Material: Displays the vessels ordered alphabetically by material. ■ Name: Displays the vessels ordered alphabetically by name. ■ All Same Size: Displays all vessels as the same size in one window (without scrolling). ■ Manual 4x4, 5x5 and 6x4: Displays the vessels arranged in a matrix with the selected dimensions. ■ Manual: Displays the vessels arranged in a matrix with dimensions as defined in Tools > Client Options > Site - Vessel > Site View Manual Layout. <p>When selecting a sorting option other than All, the site display changes and shows the vessels in groups arranged according to the sorting criteria, as shown in the following image:</p> <div data-bbox="906 737 1300 1115" style="border: 1px solid gray; padding: 5px;"> </div> <p style="text-align: center;">Sort By: Name view</p> <p>The Manual sorting options display the vessels with different sizes in accordance with the selected option. Smaller sizes may be more convenient when managing a large site. For example, selecting Manual 4x4 displays the vessels as follows:</p> <div data-bbox="776 1297 1370 1570" style="border: 1px solid gray; padding: 5px;"> </div> <p style="text-align: center;">Sort By Manual</p>
<div data-bbox="167 1696 380 1751" style="background-color: #0056b3; color: white; padding: 5px; display: flex; align-items: center;"> ● Connected </div>	<p>Connection status</p>	<p>Indicates the client connection to the server. See “Alert types” on page 152.</p>

7.4.5 Vessel selection behavior

Vessels are displayed in blocks in the main work area. Each vessel is represented by a rectangle with the following information:

- The vessel image containing the material stored using the selected material color at its current level/distance.
- Stored material name and device model.
- Empty and full calibration levels represented by orange and red lines respectively.
- Level measurements: Average level/distance, maximum level and minimum level/distance, in the configured measurement units, and volume in percentage. Additional information can be added by right clicking the vessel. For more information, refer to “Parameters and alerts” on page 152.
- A connection status indicator: Note that in the case of a connection failure, the indicator and the entire background of the rectangle becomes red.

Figure 7-44. Main Work Area

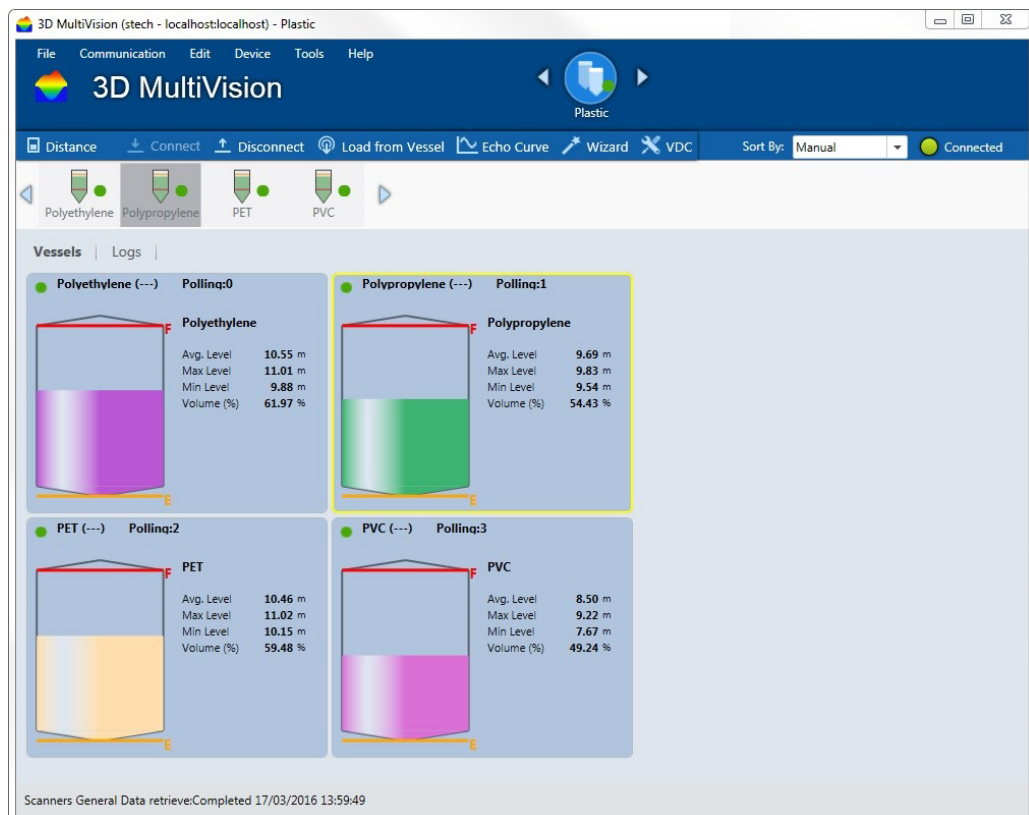

Double-clicking a vessel icon in the vessel selection bar replaces the display with a detailed vessel pane in the main work area, with the Overview tab selected.

Figure 7-45. Detailed Vessel Pane when Double-clicking a Vessel Icon

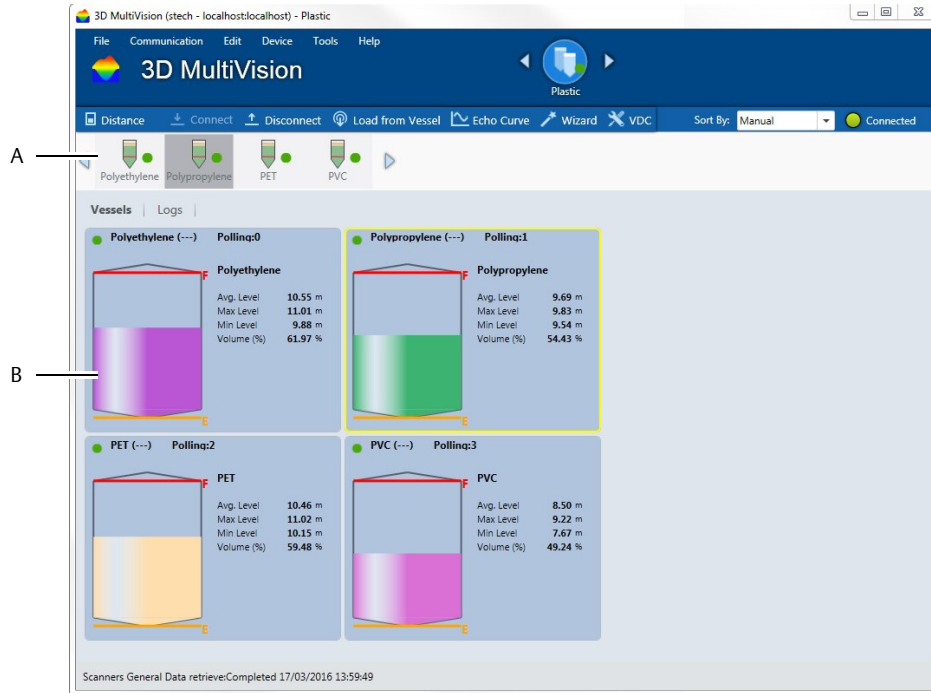

- A. Double-click a vessel icon to view a detailed vessel pane in the main work area
- B. Detailed vessel pane

Right-clicking the vessel icon opens a drop-down menu with the following features:

- **Connect:** Connects to the devices on the vessel.
- **Disconnect:** Disconnects communication between the server and the Rosemount 5708.
- **Load from Vessel:** Downloads all parameters from the devices connected to the software.
- **Generate report (logs data) - Download from server... :** Opens the Search Log window for selecting a report date and time. Then it downloads the corresponding historical data from the server and opens a Save As dialog box to save the report file.
 - The report file is created in PDF format and includes the date, time, project, and vessel details, and volume/mass and alert parameters for the selected date and time.
 - The report also includes a 3D visualization of the corresponding vessel.
- **Generate report (logs data) - From local folder...:** Opens a Browse for Folder dialog box to browse to the folder where the related data is stored. Creates a report as described above, but per data stored locally.
- **Property...:** Opens the Parameters Definition window allowing the user to select the visible material properties in the representing rectangle and the alert types to be used for that vessel. For further details regarding alerts, see “3D visualization” on page 128.

Figure 7-46. Vessel Selection

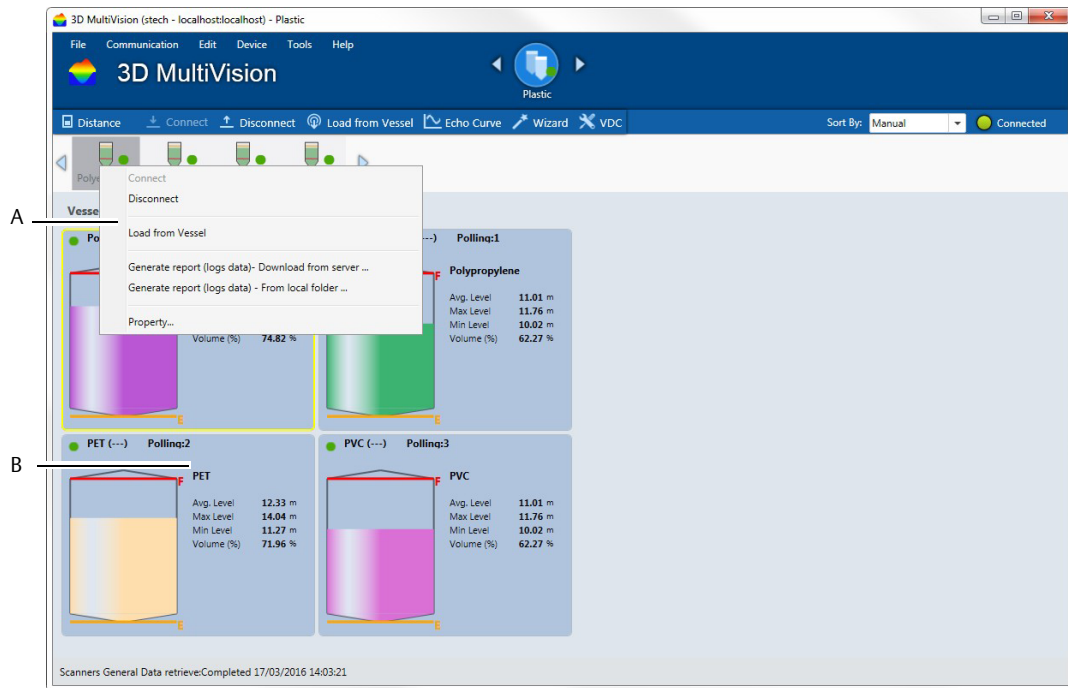

- A. Right-click the vessel icon to open a drop-down menu
- B. Click a vessel in the main work area to select the vessel

A single click selects the vessel. The selected rectangle becomes outlined with a yellow frame, and the corresponding vessel icon in the vessel selection bar is selected.

When right-clicking a selected vessel in site view, the drop-down menu opens with the following added options:

- **Show 3D Profile...:** Opens a 3D visualization window.
- **Connect:** Connects communication between the selected vessel Rosemount 5708 and the server.
- **Disconnect:** Disconnects communication between the selected vessel Rosemount 5708 and the server.
- **Load from Vessel:** Loads data from the vessel Rosemount 5708 and updates the displayed status and parameters.
- **Device Configuration Wizard...:** Opens the Configuration Wizard for the selected vessel.
- **Advanced Parameters...:** Opens the Advanced Parameters window.
- **Echo Curve Analysis...:** Opens the Echo Curve Analysis window.
- **False Echo Mapping...:** Opens the False Echo Mapping window.
- **Edit:** Allows for adding a new device to the selected vessel or deleting the entire vessel.
- **Generate report (logs data) – Download from server...:** Opens the Search Log window for selecting a report date and time. It then downloads the corresponding historical data from the server and opens a *Save As* dialog box to save the report file.

- The report file is created in PDF format and includes the date, time, project and vessel details, and volume/mass and alert parameters for the selected date and time.

- The report also includes a 3D visualization of the corresponding vessel.

- **Generate report (logs data) - From local folder...:** Opens a Browse for Folder dialog box to browse to the folder where the related data is stored. Creates a report as described above, but per data stored locally.
- **Material Selection...:** Opens the Material Configuration window allowing the user to select a stored material for the specific vessel.
- **Properties...:** Opens the Parameters Definition window allowing the user to select the visible material properties in the representing rectangle and the alert types to be used for that vessel. For further details regarding alerts, refer to “Parameters and alerts” on page 152.

Figure 7-47. Right-clicking a Selected Vessel in Site View

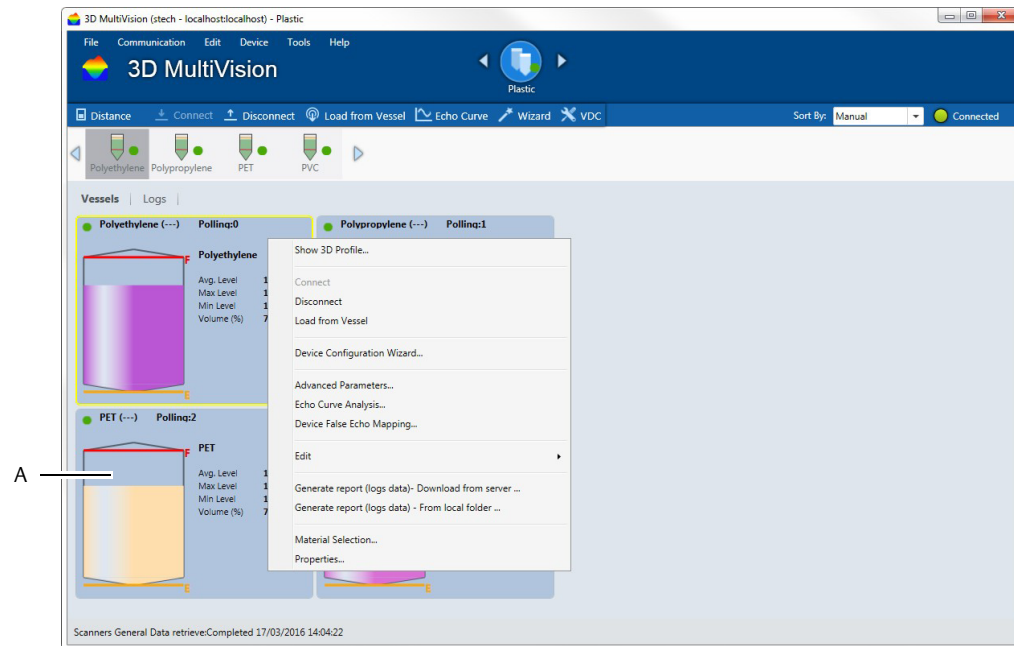

A. Right-click a selected vessel to open a drop-down menu

7.4.6 Vessel pane

The Vessel pane provides vessel monitoring options and basic vessel operations (Figure 7-48). This pane opens in the main work area when a vessel is selected from the vessel selection bar.

Figure 7-48. Vessel Pane

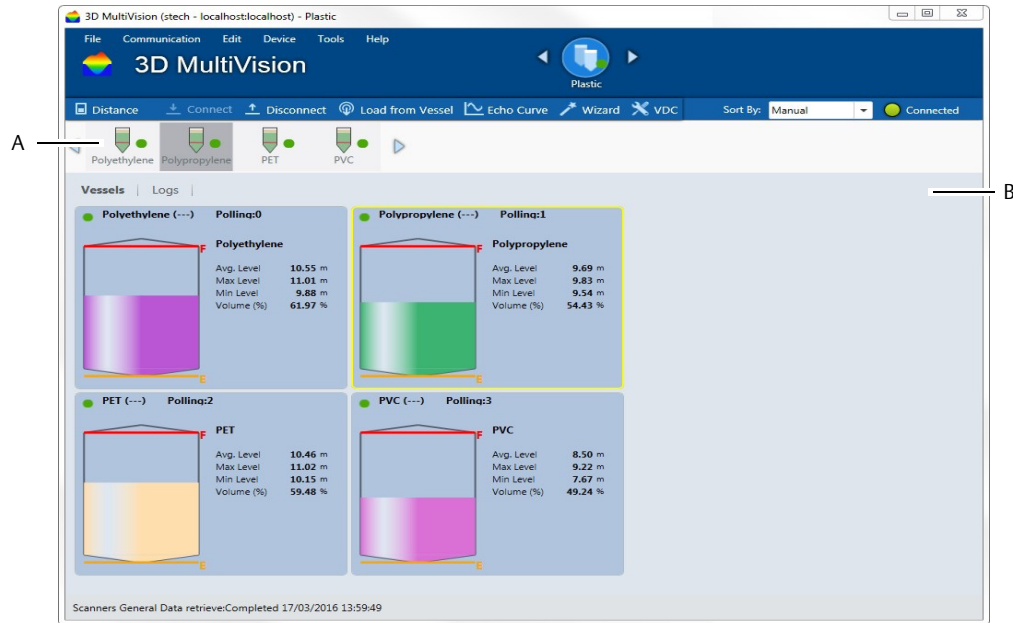

- A. Vessel selected from the vessel selection bar
- B. Device drop-down list

Overview tab

Selecting the *Overview* tab displays two panes in the main work area.

The left pane includes the vessel connection information, alerts, measurements, and indications related to the selected vessel:

- Vessel name, connection status of the vessel, and selected devices
- Alerts, if they exist
- Device names, versions, and communication details
- Average, Minimum and Maximum Level/Distance
- Volume (%), Volume in the selected units and max scale
- Mass (if density is defined) and max scale
- Temperature
- SNR
- Rosemount 5708 Output Current
- A graphical representation of the vessel, including the vessel shape, maximum and minimum levels, and connection status indicator.

Material button: Opens the Material Configuration window which allows for managing the materials in the vessel. The material can be chosen out of a pre-defined list of materials and their representing colors.

When a device is selected from the device list (when the user is with technician privileges), the following information is also displayed:

- Scanner Name
- Connection Type
- COM Port
- Polling Address
- S/N – electronic card serial number
- Hardware Version
- Firmware Version
- Device model

Logs tab

The Logs tab provides a chart representation of historical measurements data and allows for different manipulations of chart inspection. For further details, refer to [“Log views” on page 146](#).

Parameters tab

Selecting the *Parameters* tab, the following parameters are displayed in the main work area:

- Vessel SCADA ID
- Scanner
- Poll Addr
- S/N
- Hardware
- Firmware
- Device Type
- Avg. Level
- Max. Level
- Min. Level
- Volume
- Temperature
- SNR
- Current Output (mA)

Devices Tab

Selecting the Devices tab displays and allows modifying the communication settings. In addition, it show the Rosemount 5708 Polling Address, or a list of device polling addresses for a vessel with multiple Rosemount 5708 in a system configuration vessel. Option modifications are not allowed when devices are connected. Click Disconnect next to the device or at the toolbar and modify communication as needed. Multi-scanner vessels may include Rosemount 5708 units with different polling addresses that are not in series.

For a detailed explanation regarding the various ways of connect to a Rosemount 5708, [“Communication methods” on page 91](#).

Device parameters

When a device is selected from the device drop-down list (see [Figure 7-48](#)), the device parameters are displayed. When mounting more than one Rosemount 5708 in one vessel, select the device from the drop-down list and configure its parameters in the tab of that specific Rosemount 5708.

This operation allows viewing the Rosemount 5708 specific measurements and logs. This selection is useful when a vessel with multiple Rosemount 5708 in a system is connected.

7.5 Advanced tools

The following sub-sections describe several useful tools for configuration, system administration, and reports handling.

7.5.1 Communication methods

The Rosemount 3DVision Server allows various connection methods: HART®, RS-485, TCP/IP, GPRS, GPRS+SMS and Smart GPRS, this chapter will explain each of the methods.

Communication method can be changed at any time when entering the Rosemount 3DVision Client using Technician rights, to create technician user, refer to “[User management](#)” on page 126.

HART

HART communication to the Rosemount 5708 requires a HART compatible modem. It can be either a USB or a Serial RS-232 modem connected to the computer running the application, when the COM Port is known. Note that only one Rosemount 5708 can be connected to the HART modem. For additional information, refer to [Section 4: Electrical Installation](#).

To set the HART Communication:

- Select the COM Port in which the HART modem is connected to and select **Finish**.

Note

The Rosemount 5708 is not fully HART complaint and cannot be configured with HART hand held device.

Figure 7-49. HART Connection Type

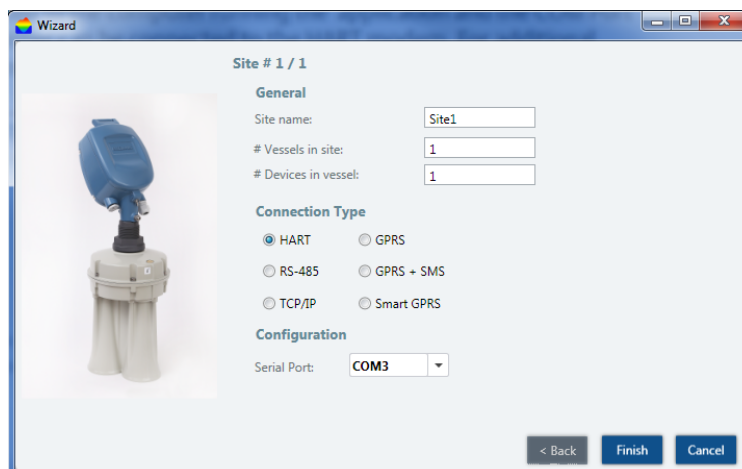

RS-485

RS-485 communication requires a converter from RS-485 to USB or RS-232 to be connected to an available COM Port (or USB port) in the computer.

To set the RS-485 communication:

Select the COM Port which the RS-485 converter is connected to and select **Finish**.

Figure 7-50. RS-485 Connection Type



TCP/IP

The TCP/IP option allows converting and transferring the RS-485 data over TCP/IP using a compatible converter. When establishing a connection to the TCP/IP converter, the local IP address and the TCP port values must be set as defined in the converter.

To set the TCP/IP connection:

TCP/IP: The Rosemount 5708 is connected via a TCP/IP network to an RS-485 connection.

1. Set the site name in the phonebook.
2. In the Server IP Address box, type the Server IP address and the Server IP port number in the right fields.
 - Server IP is the device converting RS-485 to TCP/IP.
 - IP Port is the TCP Port assigned to in the TCP/IP converter.
3. Select **Finish**.

Figure 7-51. TCP/IP Connection Type

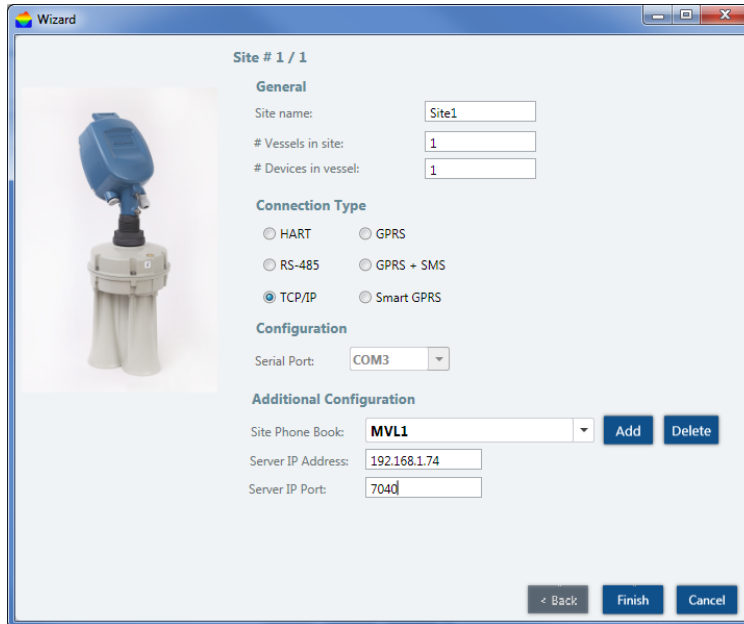

GPRS

The GPRS option allows IP connection to a remote Rosemount LinkPro with GPRS enabled. When selecting this option, a TCP port must be opened in the local network and to be forwarded to the computer running the Rosemount 3DVision.

After selecting **Connect**, an SMS message should be sent manually to the Rosemount LinkPro in the following format:

CALLAPM,[external IP address],[TCP Port],[APN],

Note

A comma must end the SMS message.

For example:

CALLAPM,82.123.25.102,7024,Internet,

GPRS: The Rosemount 5708 is connected through the Internet over GPRS using Rosemount LinkPro.

1. Enter the local IP port number assigned to the computer.
2. Select **Finish**.
3. Before selecting the connect button, send an SMS message from a mobile phone to the Rosemount 5708 to initiate the connection.

Note

Prior to connecting via GPRS, the local IP port must be configured in the router, using the Port Forwarding configuration. Contact your local IT administrator to do the router configuration.

Figure 7-52. GPRS Connection Type

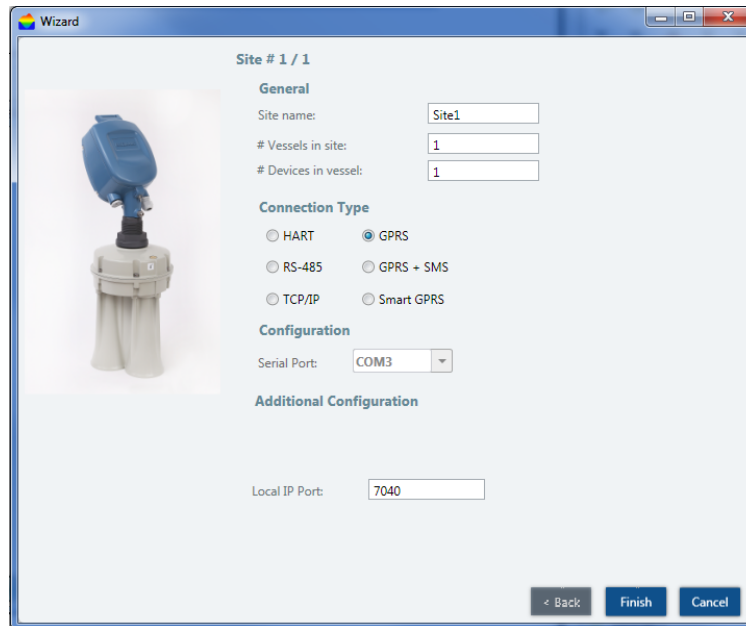

GPRS + SMS

The Rosemount 5708 is connected via the Internet using Rosemount LinkPro. This connection uses SMS messages sent from another Rosemount LinkPro with a SIM card capable of sending SMS messages that is connected to a serial COM Port on the same computer running the Rosemount 3D Vision Server.

1. Select the serial COM port of the Rosemount LinkPro connected to the computer.
2. Select or set site name.
3. Set phone number of the Rosemount LinkPro connected to the Rosemount 5708.
4. Set the computer local IP port.
5. Set the external IP address (usually the router IP address).
6. Set the APN of the Rosemount LinkPro connected to the Rosemount 5708.
7. Select **Finish**.

Figure 7-53. GPRS + SMS Connection Type

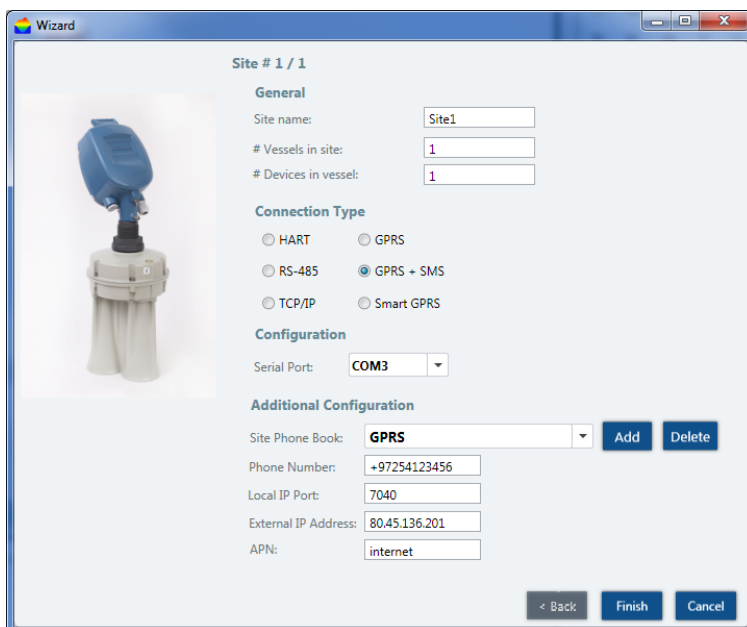

The screenshot shows a 'Wizard' window titled 'Site # 1 / 1'. On the left is an image of a blue and white industrial device. The right side contains configuration fields:

- General:** Site name: Site1; # Vessels in site: 1; # Devices in vessel: 1.
- Connection Type:** Radio buttons for HART, GPRS, RS-485, GPRS + SMS (selected), TCP/IP, and Smart GPRS.
- Configuration:** Serial Port: COM3 (dropdown).
- Additional Configuration:** Site Phone Book: GPRS (dropdown) with 'Add' and 'Delete' buttons; Phone Number: +97254123456; Local IP Port: 7040; External IP Address: 80.45.136.201; APN: internet.

Buttons at the bottom: < Back, Finish, Cancel.

Smart GPRS

Same settings as GPRS + SMS configuration with a difference of the SMS Server.

The SMS Server is a small application sold separately by Emerson and designed for GPRS connections from different computers using one static source for sending the SMS messages to initiate the GPRS communication.

The additional two fields to set are the computer IP Address running the SMS Server and the TCP Port in use, by default the port is 9669.

This option is available only for Senior Technician users.

Figure 7-54. Smart GPRS Connection Type

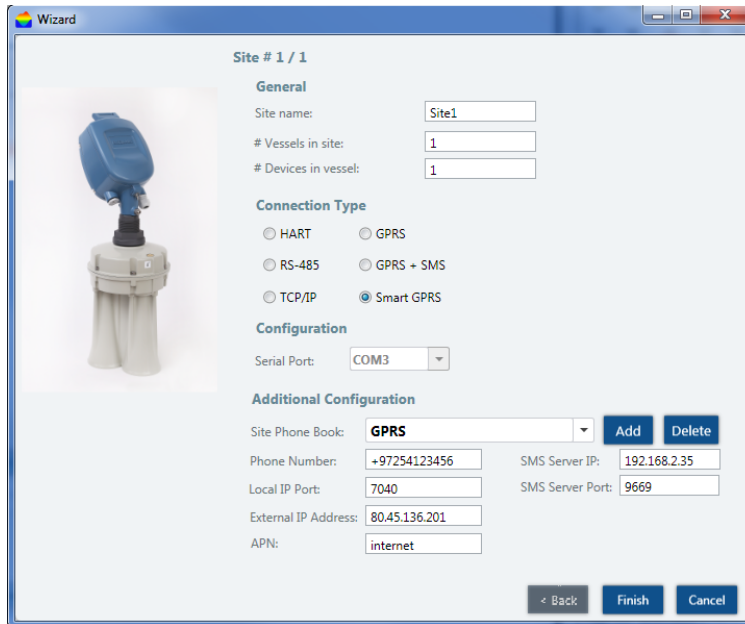

7.5.2 Advanced parameters

Algorithm parameters can be adjusted in the Advanced Parameters window. The various fields can be downloaded or uploaded from/to the Rosemount 5708. Any changed parameter, if not uploaded to the device, can be discarded using the Close button at the bottom, see [Figure 7-55 on page 97](#). Emerson recommends consulting an Emerson official distributor or Emerson Technical Support before changing any of the parameters.

The Advanced Parameters window is available when Technician and Senior Technician users are logged on. Technician users have limited access to the parameters.

To open the Advanced Parameters window:

Select **Device > Advanced Parameters** or press **F3**.

Figure 7-55. Advanced Parameters

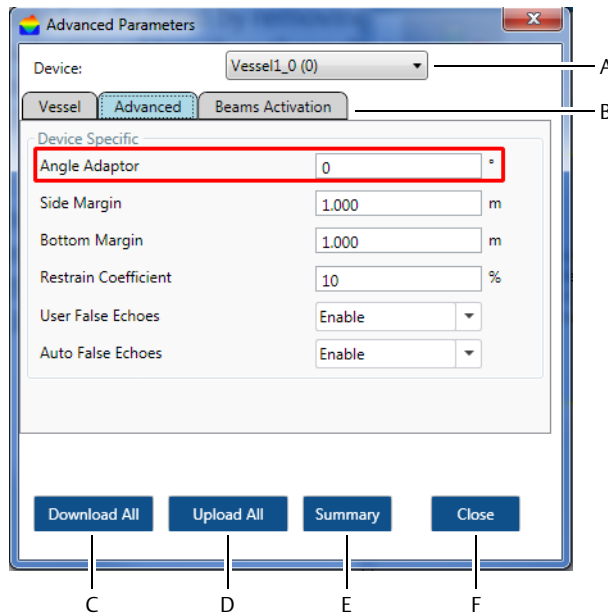

- A. Device drop-down list
- B. Parameters tabs:
 - Vessel
 - Advanced
 - Beams Activation
- C. Download all
- D. Upload All
- E. Summary
- F. Close

Device drop-down list: This list will hold all devices in the vessel, it is possible to select any of the devices.

Parameters tabs: Switch between the Vessel, Advanced Parameters, and Beams Activation tabs for various functions.

Download all: Download all configured parameters from the devices to the software. If any changes happen beforehand, it will be seen in parameters changing accordingly in the window.

Upload all: The first five parameters must be the same, when changing one and selecting **Upload all** it will upload all five parameters to all the devices connected in the vessel.

Summary: Open a summary table in a separate window to show all devices and their parameters in a single table. See [Figure 7-56 on page 97](#).

Close: Close the Advance Parameters window.

Figure 7-56. Advanced Parameters Summary Table

Name	Output Damp	Steepest Mat	Max. Capacity	Max. Empty	Max. Filling R	Mechanics Ty	Threshold Ser	Minimal SNR	Restrain Coef	Side Margin	Bottom Marg	Top Dead Bar	Keep Logs Lo	User False Ecl	Auto False Ecl	User False Ecl	Auto False Ecl	Exceeding Fill	Angle
Vessel1_0	60	35.000	1	100	100		7	13	10	1.000	1.000	Do not Discar	Do not gener	Enable	Enable	1,200	1,200	Yes	0

Vessel tab

Figure 7-57. Advanced Parameters - Vessel Tab

Advanced Parameters

Device: Silo 123_0 (0)

Vessel Advanced Beams Activation

Output Damping Time: 300 sec

Steepest Material Slope: 30 °

Max. Capacity: 100 mass

Max. Emptying Rate: 10 mass/h

Max. Filling Rate: 10 mass/h

Download All Upload All Summary Close

Output Damping Time: Sets the history damp window time of the Rosemount 5708. This parameter increases stability and improves the SNR. Default value: 300 seconds, minimum value: 60 seconds. It is recommended increasing this value when configuring a multiple Rosemount 5708 in a system.

Steepest Material Slope: Set the maximum material slope. The Rosemount 5708 verifies all echoes for not exceeding the slope. Default: 35°. Recommended settings: between 30° to 45°.

Max. Capacity [mass]: The total capacity of material within the vessel. Default: 100

Max. Emptying Rate [mass/hour]: The maximum emptying rate. Default: 10

Max. Filling Rate [mass/hour]: The maximum filling rate. Default: 10

Note

It is recommended to set the maximum capacity and Filling/Emptying rates according to the actual process in the vessel.

Advanced tab

Figure 7-58. Advanced Parameters - Advanced Tab

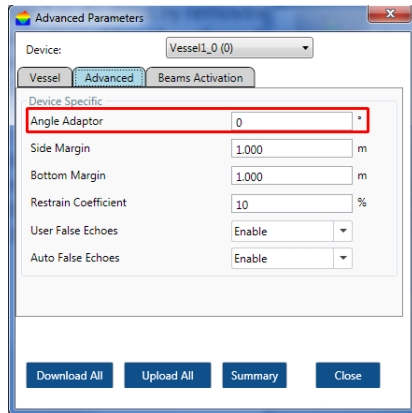

Angle Adaptor: In case the antennas are installed in an angle with a Rosemount angle adapter or with other mechanical solution it is required to adjust the angle in the configuration. By default, the angle is set to 0°, maximal value is 30°.

Side Margins [m/ft]: Allows tolerance in echo recognition to vessel walls (see figure). Used for creating a tolerance in case of unknown vessel width/diameter, and when a tolerance is required for detecting points on the vessel walls

Echo within the tolerance/margin range is transformed to the vessel wall on the X-Y plane and will not be eliminated in calculation. Default: 1 m (3.28 ft.).

Bottom Margins [m/ft]: Allows adding a tolerance in echo recognition from the bottom shape (see figure). This feature is used for creating a tolerance in the case of unknown vessel dimensions, and when a tolerance is required for detecting points from the bottom of the vessel. Default: 1 m (3.28 ft.)

Restrain Coefficient [%]: Sets the level of preference of echoes from shorter distances over echoes from farther distances. 100% = no preference of closer echoes. 0% = total preference of the first echo. Default: 10%.

User False Echoes: Enable/Disable, Sets the algorithm to consider the false echo mapping created manually by the user (enabled by default). Setting this parameter to Disable causes the device to ignore the manual false echoes.

Auto False Echoes: Enable/Disable, Sets the algorithm to automatically calculate false echo levels (enabled by default). Setting this parameter to Disable stops the device from continuously calculating the false echo levels and keeps the last image of false echoes. If the false echoes are manually reset, the level is set to 0.

Figure 7-59. Side and Bottom Margins

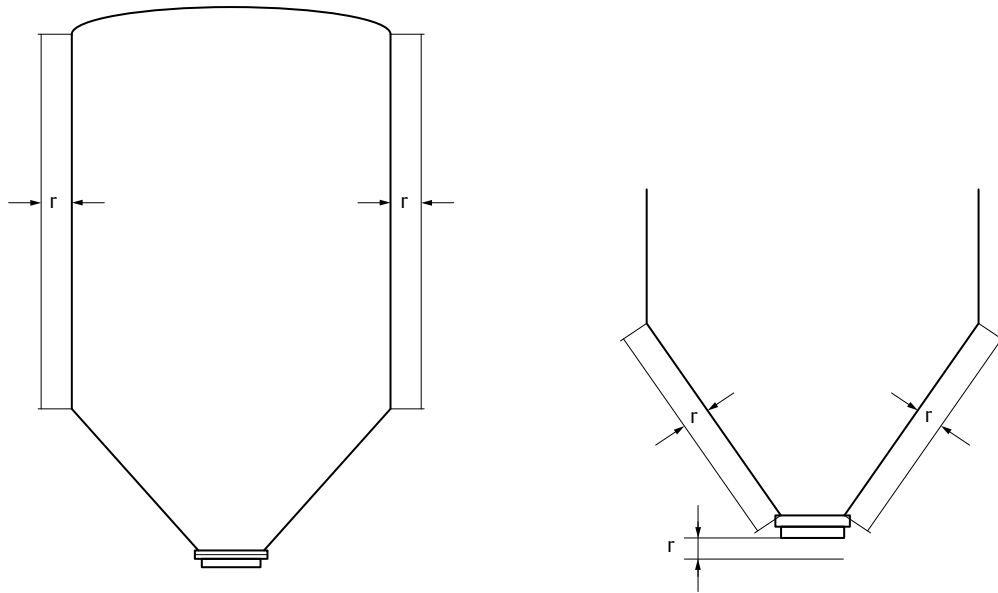

r = Bottom Margins

Beams Activation tab

The Beams Activation tab allows choosing manual or automatic (by the algorithm) beams selection. By default, the beams are selected automatically. Part of the beams will be removed depending on silo dimensions.

- **High** (7KHz), **Med** (4.5KHz) and **Low** (2.3KHz) Frequency beams represent three separate transmissions which emit signals from all three antennas simultaneously.
- **30, 90, 150, 210, 270 and 330 degrees directions** represent six separate directional transmissions which improve the algorithm's analysis of the returned echoes. All six transmissions are transmitted in the same frequency as the **Med** frequency.
- Beams can be enabled or disabled by removing the check box from the **Auto Beam Selection** box. A selection of less than three directional beams is not allowed. Only a selection of at least three consecutive beams is possible, for example: Direction 30, Direction 330 and Direction 270.
- **Automatic Beams Range:** Enabled by default. The beams range is limited according to the range at which the beam hit the vessel wall. Low frequency beam has wider angle and thus is more limited. High frequency beam is very narrow and has no limitations. At every possible beam selection the algorithm makes sure that at least one beam has enough range to 'see' the bottom of the vessel. This limitation is visualized in the Echo Curve analysis window as the orange vertical line.

Figure 7-60. Advanced Parameters - Beams Activation

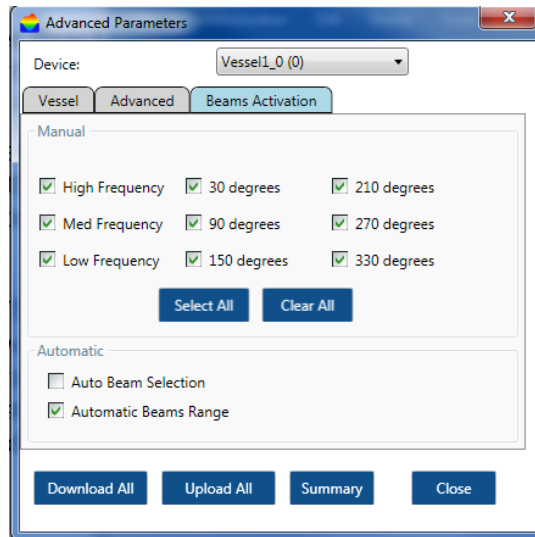

7.5.3 Device current simulation settings

The output current can be simulated by setting Volume (%), or Current (mA). This feature is useful for synchronizing with the PLC and verifying of identical read values for both the Rosemount 5708 and the PLC.

1. On the *Device* menu, select **Device Current Simulation Settings** or press **F6**.
2. Select **Volume** or **Current Simulation** from the drop down list and fill the value field, volume can be between 0 to 100%. Current simulation settings can be between 4 to 20mA.
3. Select **Apply** to set the changes in the device, to stop current simulation select 'Simulation Off' and select **Apply**.

The Current simulation status of the device may be terminated by either restart or power reset.

Figure 7-61. Current Simulation Settings

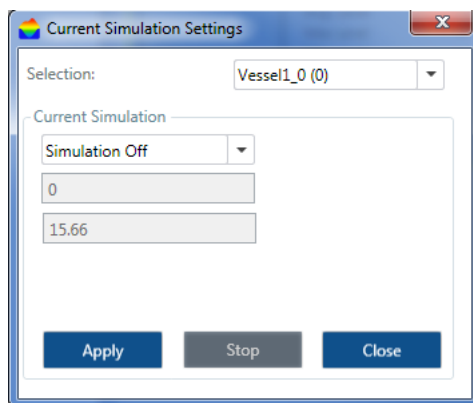

Note

Turn off current simulation by selecting **Simulation Off** and select **Apply**.

7.5.4 Device output current

These settings allowing the user to control the various options of the 4-20mA connection. Setting the output to represent volume of level, setting fault current and conditions and changing the HART command #3 to different values.

Current Output Types

Standard 4-20mA (Volume) - the current will represent the volume of the material in the vessel based on vessel configuration and settings.

Standard 4-20mA (Level) - the current will follow the level of material inside the vessel and be calculated based on the full and empty calibration levels. It is also possible to select whether the current will be the average level, minimal level or maximal level. Min and Max levels are available only if the model is Rosemount 5708V or 5708S.

Inverted 20-4mA (Distance) - the current will follow the distance of material inside the vessel and be calculated between the full and empty calibration level. It is also possible to select whether the current will be the average distance, minimal distance or maximal distance. Min and Max distances are available only if the model is Rosemount 5708V or 5708S.

From the Device menu, select **Device Output Current** or select the **F8** key on your keyboard.

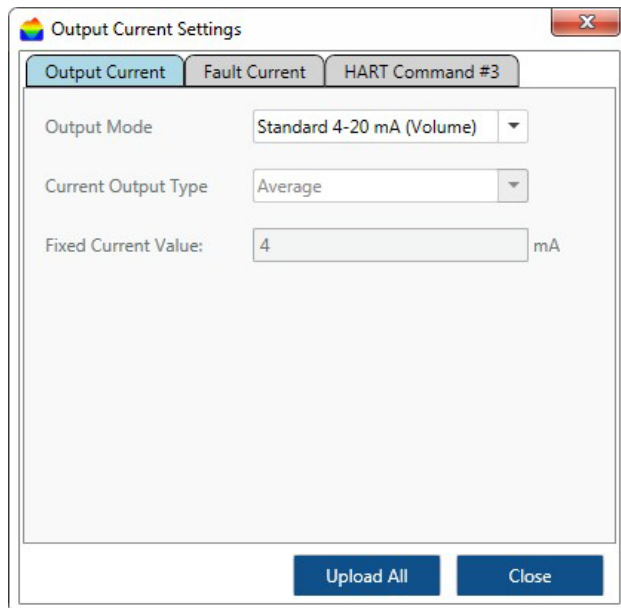

Note

Distance in multi-scanner system is calculated from the top of the silo.

Fault Current settings - selecting an output signal and the condition to activate it. The fault current can be 3.6mA or 22mA, by default there is no fault current. Fault indication trigger can be by temperature or volume measurement.

HART Command #3 - changing the 4 default variables to any combination of the available measurement variables.

7.5.5 Device output settings

The Device Output Settings defines the displayed calculation and how the 4-20mA output behaves. The output type of Volume (default), Mass, Level or Distance can be selected.

Material name and color can be selected from the list of materials and edited. For additional details, see “Material configuration” on page 127.

Rosemount 5708 measurement units can be modified. The measurement units are the same as defined in the Configuration Wizard.

On the *Device* menu, select **Device Output Settings** or press **F7**.

Output type: volume

Calculation Using Silo Structure – Calculates the volume based on the silo structure defined using the configuration wizard. The displayed units can be selected to be available to the user.

Figure 7-62. Output Type Volume by Silo Structure

The screenshot shows the 'Output Settings...' dialog box. At the top, there is a 'Material Name' field with a dropdown arrow and an 'Edit...' button. Below this is the 'Calculation Using' section with six radio button options: 'Silo Structure' (selected), 'Level-Mass Table', 'Level-Volume Table', 'Distance-Mass Table', 'Distance-Volume Table', and 'Level-Variable Bulk Density'. The 'Distance-Variable Bulk Density' option is also present. The 'Measurement Units' section contains two dropdown menus: 'Distance:' set to 'm' and 'Temperature:' set to 'Celsius'. The 'Mass' section has a 'Display Units:' dropdown set to 'Tons (Metric)' and a 'Density' field with the value '0.68' and a unit dropdown set to 'ton/m^3'. The 'Volume' section has a 'Display Units:' dropdown set to 'meter^3' and a 'Max Scale' field with the value '225.31'. At the bottom, there are three buttons: 'Edit Table...', 'OK', and 'Close'.

Calculation Using Level-Volume Table – Allows setting a linearization table based on level to volume conversion.

Figure 7-63. Output Type Volume by Level-Volume Table

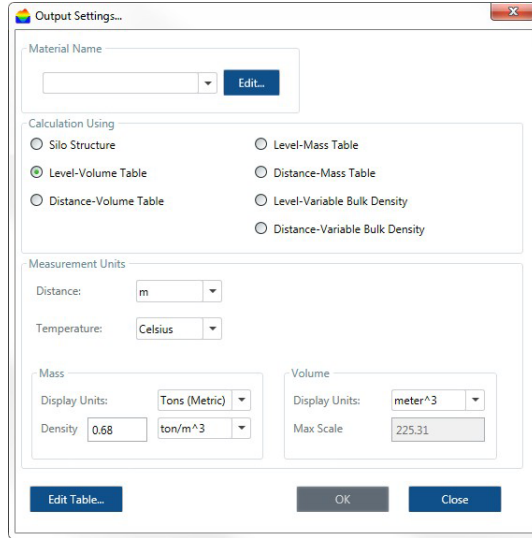

Select **Edit Table...** to edit the Level-Volume Linearization table.

If the Level to Volume option is selected, the 2 editable columns are Level [m] and Volume [m³], as shown in Figure 7-64.

Figure 7-64. Level-Volume Linearization Table

#	Level [m]	Distance [m]	Volume [%]	Volume [m ³]
1	0.00	14.00	0.00	0.00
2	0.15	13.85	0.02	0.04
3	0.30	13.70	0.06	0.13
4	0.45	13.55	0.12	0.26
5	0.60	13.40	0.20	0.46
6	0.75	13.25	0.32	0.73
7	0.90	13.10	0.48	1.08
8	1.05	12.95	0.68	1.54
9	1.20	12.80	0.93	2.10
10	1.35	12.65	1.24	2.79
11	1.50	12.50	1.60	3.61
12	1.65	12.35	2.03	4.57
13	1.80	12.20	2.53	5.70
14	1.95	12.05	3.10	6.99
15	2.10	11.90	3.76	8.47
16	2.25	11.75	4.50	10.13
17	2.40	11.60	5.33	12.01
18	2.55	11.45	6.26	14.10
19	2.70	11.30	7.29	16.42
20	2.85	11.15	8.42	18.98
21	3.00	11.00	9.67	21.79
22	13.00	1.00	96.82	218.14
23	13.10	0.90	97.64	219.99
24	13.20	0.80	98.36	221.62
25	13.30	0.70	98.99	223.04
26	13.40	0.60	99.54	224.26
27	13.50	0.50	100.00	225.31
28	13.60	0.40	100.00	225.31
29	13.70	0.30	100.00	225.31
30	13.80	0.20	100.00	225.31
31	13.90	0.10	100.00	225.31
32	14.00	0.00	100.00	225.31

Calculation Using Distance-Volume Table – Allows setting a linearization table based on distance to volume conversion (to be done the same as above). In this case, the two editable columns are Distance [m] and Volume [m³], as shown in Figure 7-65.

Figure 7-65. Distance-Volume Linearization Table

#	Level [m]	Distance [m]	Volume [%]	Volume [m ³]
1	0.00	14.00	0.00	0.00
2	0.15	13.85	0.02	0.04
3	0.30	13.70	0.06	0.13
4	0.45	13.55	0.12	0.26
5	0.60	13.40	0.20	0.46
6	0.75	13.25	0.32	0.73
7	0.90	13.10	0.48	1.08
8	1.05	12.95	0.68	1.54
9	1.20	12.80	0.93	2.10
10	1.35	12.65	1.24	2.79
11	1.50	12.50	1.60	3.61
12	1.65	12.35	2.03	4.57
13	1.80	12.20	2.53	5.70
14	1.95	12.05	3.10	6.99
15	2.10	11.90	3.76	8.47
16	2.25	11.75	4.50	10.13
17	2.40	11.60	5.33	12.01
18	2.55	11.45	6.26	14.10
19	2.70	11.30	7.29	16.42
20	2.85	11.15	8.42	18.98
21	3.00	11.00	9.67	21.79
22	13.00	1.00	96.82	218.14
23	13.10	0.90	97.64	219.99
24	13.20	0.80	98.36	221.62
25	13.30	0.70	98.99	223.04
26	13.40	0.60	99.54	224.26
27	13.50	0.50	100.00	225.31
28	13.60	0.40	100.00	225.31
29	13.70	0.30	100.00	225.31
30	13.80	0.20	100.00	225.31
31	13.90	0.10	100.00	225.31
32	14.00	0.00	100.00	225.31

Calculation Using Level-Mass Table – Conversion of the calculated average level directly into mass.

Figure 7-66. Output Type Mass by Level-Mass Table

Select **Edit Table...** to edit the Level-Mass Linearization table.

If the Level to Mass option is selected, the 2 editable columns are Level [m] and Mass [ton], as shown in Figure 7-67.

Figure 7-67. Level-Mass Linearization Table

#	Level [m]	Distance [m]	Mass [%]	Mass [ton]
1	0.00	14.00	0.00	0.00
2	0.15	13.85	0.02	0.04
3	0.30	13.70	0.06	0.13
4	0.45	13.55	0.12	0.26
5	0.60	13.40	0.20	0.46
6	0.75	13.25	0.32	0.73
7	0.90	13.10	0.48	1.08
8	1.05	12.95	0.68	1.54
9	1.20	12.80	0.93	2.10
10	1.35	12.65	1.24	2.79
11	1.50	12.50	1.60	3.61
12	1.65	12.35	2.03	4.57
13	1.80	12.20	2.53	5.70
14	1.95	12.05	3.10	6.99
15	2.10	11.90	3.76	8.47
16	2.25	11.75	4.50	10.13
17	2.40	11.60	5.33	12.01
18	2.55	11.45	6.26	14.10
19	2.70	11.30	7.29	16.42
20	2.85	11.15	8.42	18.98
21	3.00	11.00	9.67	21.79
22	13.00	1.00	96.82	218.14
23	13.10	0.90	97.64	219.99
24	13.20	0.80	98.36	221.62
25	13.30	0.70	98.99	223.04
26	13.40	0.60	99.54	224.26
27	13.50	0.50	100.00	225.31
28	13.60	0.40	100.00	225.31
29	13.70	0.30	100.00	225.31
30	13.80	0.20	100.00	225.31
31	13.90	0.10	100.00	225.31
32	14.00	0.00	100.00	225.31

Calculation Using Distance-Mass Table – Conversion of the calculated average distance directly into mass (to be done same as above).

Figure 7-68. Distance-Mass Linearization Table

Material Name: [] Edit...

Calculation Using:

- Silo Structure
- Level-Mass Table
- Level-Volume Table
- Distance-Mass Table
- Distance-Volume Table
- Level-Variable Bulk Density
- Distance-Variable Bulk Density

Measurement Units:

Distance: [m]

Temperature: [Celsius]

Mass Display Units: [Tons (Metric)]

Edit Table... OK Close

Calculation Using Level-Variable Bulk Density Table – Conversion of the calculated average level into volume, based on silo structure and multiplying by the bulk density value at that level to convert into mass.

Figure 7-69. Output Type Mass Using Variable Bulk Density

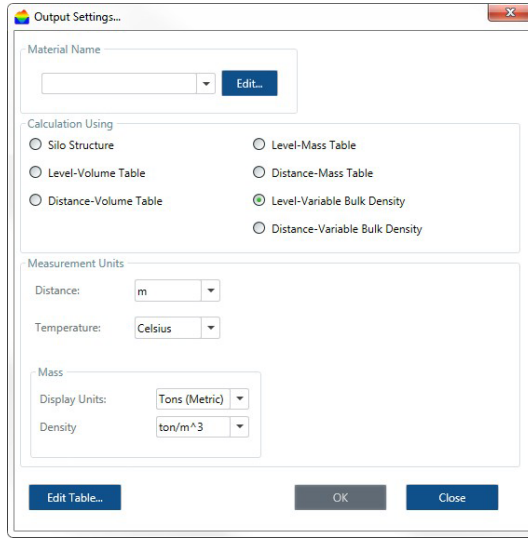

Select **Open Table...** to open the Level-Bulk Density Linearization table.

If the Level to Variable Bulk Density option is selected, the 2 editable columns are Level [m] and Dens. [ton/m³], as shown in Figure 7-70.

Figure 7-70. Level-Bulk Density Linearization Table

#	Level [m]	Distance [m]	Mass [%]	Mass [ton]	Dens. [ton/m ³]
1	0.00	14.00	0.00	0.00	0.00
2	0.15	13.85	0.02	0.04	1.00
3	0.30	13.70	0.06	0.13	1.00
4	0.45	13.55	0.12	0.26	1.00
5	0.60	13.40	0.20	0.46	1.00
6	0.75	13.25	0.32	0.73	1.00
7	0.90	13.10	0.48	1.08	1.00
8	1.05	12.95	0.68	1.54	1.00
9	1.20	12.80	0.93	2.10	1.00
10	1.35	12.65	1.24	2.79	1.00
11	1.50	12.50	1.60	3.61	1.00
12	1.65	12.35	2.03	4.57	1.00
13	1.80	12.20	2.53	5.70	1.00
14	1.95	12.05	3.10	6.99	1.00
15	2.10	11.90	3.76	8.47	1.00
16	2.25	11.75	4.50	10.13	1.00
17	2.40	11.60	5.33	12.01	1.00
18	2.55	11.45	6.26	14.10	1.00
19	2.70	11.30	7.29	16.42	1.00
20	2.85	11.15	8.42	18.98	1.00
21	3.00	11.00	9.67	21.79	1.00
22	13.00	1.00	96.82	218.14	1.00
23	13.10	0.90	97.64	219.99	1.00
24	13.20	0.80	98.36	221.62	1.00
25	13.30	0.70	98.99	223.04	1.00
26	13.40	0.60	99.54	224.26	1.00
27	13.50	0.50	100.00	225.31	1.00
28	13.60	0.40	100.00	225.31	1.00
29	13.70	0.30	100.00	225.31	0.99
30	13.80	0.20	100.00	225.31	0.99
31	13.90	0.10	100.00	225.31	0.99
32	14.00	0.00	100.00	225.31	0.99

Calculation Using Distance-Variable Bulk Density Table – Conversion of the calculated average distance into volume, based on silo structure and multiplying by the bulk density value at that distance to convert into mass (same as above).

Rosemount 5708 output settings button functions

Output Settings windows buttons functionality:

- **Edit Table** – when available, the table can be edited according to the requirements
- **OK** – keeps settings and advise upload the changes to the device
- **Close** – discards all changes and close the window

Table buttons and functionality:

- **Export/Import:** Exports or imports .xml file.
- **Reset Levels** – Set the level/distance values
- **Apply** – upload all updated settings to the device
- **OK** – saves the configuration. Uploading from the output settings window will be required
- **Close** – discards all changes and closes the table window

Table editing options by right-clicking a row or column editing option available:

- Add/Clear/Delete selected row
- Duplicate row set value as min/max capacity clearing table or column.

7.5.6 Echo Curve Analysis

Performing Echo Curve Analysis

The Echo Curve Analysis tool collects information from the Rosemount 5708 and presents it in a chart -type report for each scan.

To perform an Echo Curve Analysis:

1. On the *Device* menu, select **Echo Curve Analysis...** or press **Ctrl+Z**.
2. Select the device(s) from the tree view pane. The devices are organized in a Site-Vessel-device view.
3. Optional: Select **All Echoes Info** to perform an analysis on the Rosemount 5708 to verify behavior in the vessel.
4. Select **Start** to initiate a single time Echo Curve analysis.
5. **Open Viewer** to open the Echo curve viewer.

If a single analysis scan is performed, then the Echo Curve Viewer will automatically pop up. To view the echo curve, see next chapter.

Figure 7-71. Activate Echo Curve Analysis

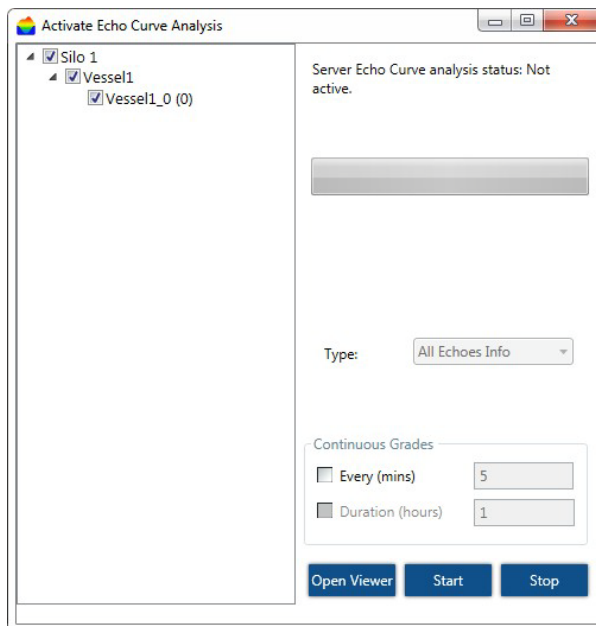

To perform continuous echo curve analysis, set the **Every (mins)** and the **Duration (hours)** and select **Start**.

- **Every (mins)**: Sets the pause time between analysis scans, the pause time is measured in minutes and by default set to five minutes. The pause time can be set between 3 to 1000 minutes.
- **Duration (hours)**: Set the period of time in hours to perform continuous analysis. Minimal value is 0.1 hour (six minutes) and maximal value is 999 hours (over 41 days).

Viewing Echo Curve Analysis

Selecting this option allows viewing of previous Echo Curve Analysis scans done. Expand the tree view and select one of the devices, the software will retrieve the information from the device and display all Echo Curve files on the right hand side of the viewer.

To view the Echo Curve Analysis:

On the *Device* menu, select **Echo Curve Analysis Viewer...** or press **Ctrl+V**.

Figure 7-72. Echo Curve Analysis Viewer

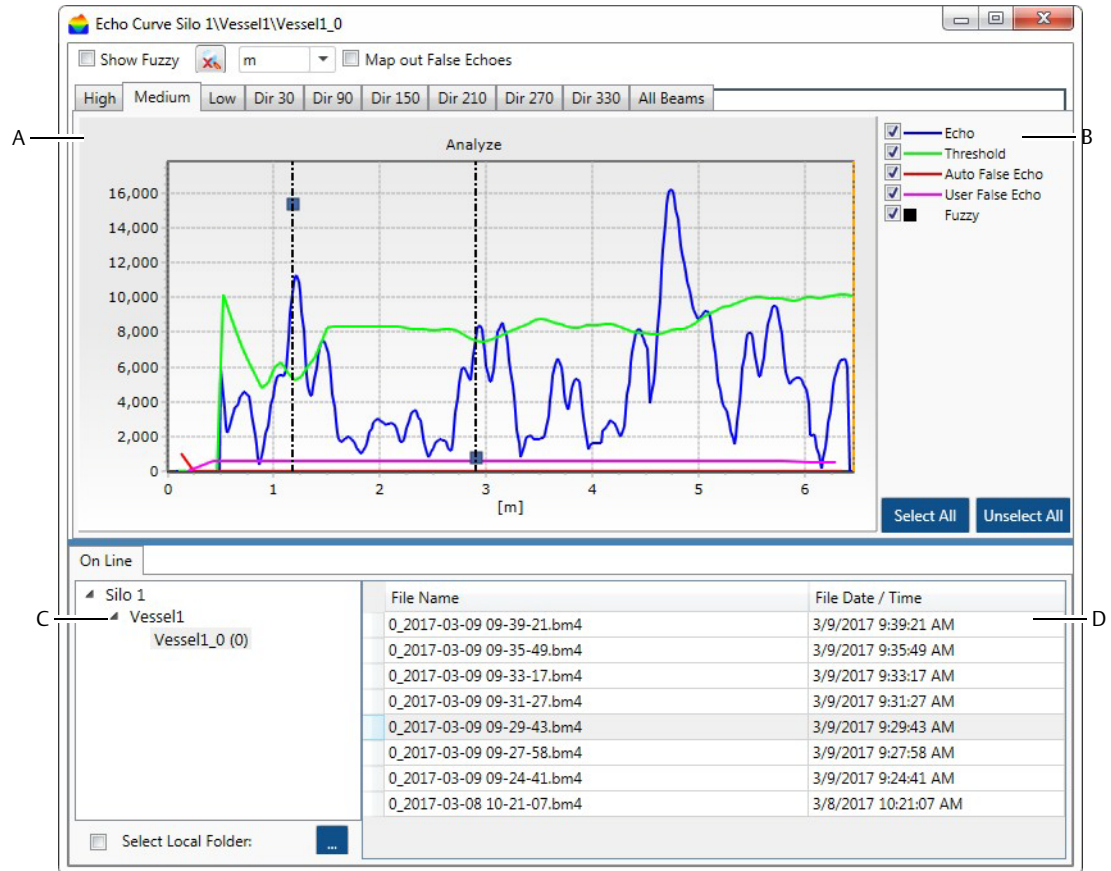

- A. Echo curve charts by beam
- B. Chart legend
- C. Selecting the device to view
- D. List of echo curve files and time and date stamp

The horizontal axis refers to the distance (m or feet) of the echo from the device and the vertical axis refers to the energy of the echo (there are no units for the energy).

Echo Curve viewer window options:

Show Fuzzy: Checking this option will show the Fuzzy Grade of the selected echoes on the chart. For more information about Fuzzy and what it is, contact your local Emerson technical support.



Reset the chart to the original view

m / ft: Show the distance axis in meters or feet.

Map out False Echoes: checking the map out checkbox allows the user to select a section in the echo curve in any of the frequency tabs and to open the false echo mapping dialog box directly with the selected frequency and conditions to easily map out selected false echo. See [“False Echo Mapping” on page 112](#) for additional info.

High/Medium/Low... tabs: Show the echo curve result of each beam, the tab will be disabled if the beam was not active when the Echo Curve analysis was performed.

All Beams tab: Show just the grade of each beam in a single chart

Chart Legend (Echo, Threshold, Auto False Echo, User False Echo and Fuzzy): Show or hide each of the selected graphs. Fuzzy will show or hide the small square on the selected echoes in different heights depending on the fuzzy grade value.

Selecting the scanner to view: In this pane, a tree view of Site-Vessel-Device will appear according to the project, expand or collapse the tree view and select the Rosemount 5708 to view its echo's result.

It is possible to set the page size (number of files) to view, default value is 50 files. Values can be between 10 to 250 files.

In the Online pane it is possible to switch between pages and to download the files to the local computer.

Download Files tab: This tab holds all the echo curve files that were viewed by the user and were automatically downloaded to the Rosemount 3DVision Client computer.

When switching to the downloaded Files tab, it is possible to Select Local folder to save the files and to browse to local folder by right-clicking on one of the files.

7.5.7 False Echo Mapping

Selecting this option allows performing False Echo Mapping on any of the beams to ignore false echoes inside the vessel cause by internal object or interferences.

To open the False Echo Mapping option:

On the *Device* menu, select **Device False Echo Mapping....**

Figure 7-73. False Echo Mapping

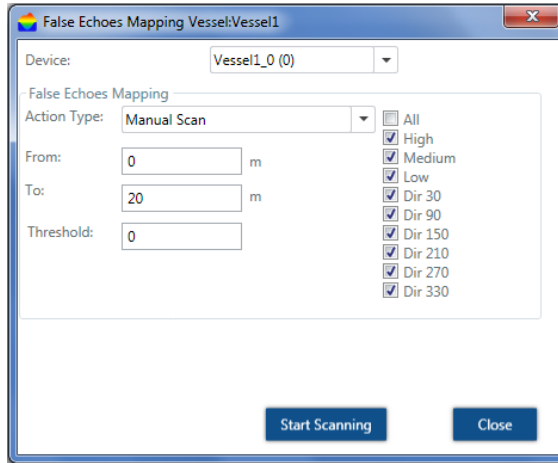

Device – select the device to perform False Echo Mapping function on.

Beams' check-boxes – it is possible to perform any of the actions on all beams or any combination of the beams.

Action Type:

- **Reset User and Auto False Echoes** – delete all false echoes done by the Auto False Echo algorithm and in the False Echoes Mapping created by the user.
- **Reset User False Echoes** – delete all false mapping done by the user.
- **Reset Auto False Echoes** – delete all false echoes done by the Auto False Echo algorithm.
- **Scan** – automatic False Echo Mapping between the set ranges From/To distance.
- **Manual Scan** – set a constant level at the defined threshold between the From and To distances.
- **Start Scanning (or Reset Mapping)** – select to start the calculation.

Suggested steps for Echo Curve Analysis and False Echo Mapping

1. Measure the distance from the device to the material below it with a second reference, such as a tape measure equipped with a weight on the end, or a laser. Record the distance measurement for further reference.
2. Perform the Echo Curve Analysis, see “[Echo curve analysis](#)” on page 62. Once completed, the *Echo Curve* window opens (same as in “[Viewing Echo Curve Analysis](#)” on page 110).
3. Determine if the location of the echoes (vertical lines) are close to the manual measurement taken earlier. Note that the Rosemount 5708 is taking measurements of multiple points and may not match up with the manual measurement exactly.
4. [Figure 7-74](#) is an example of the representation of false echo in the *Echo Curve* window. A manual measurement and reads 2.5 m. When comparing to the Echo Curve Analysis, echoes appear in the first 1m. These are clearly false echoes and will need to be mapped out.

Figure 7-74. False Echo Example in Echo Curve Analysis Window

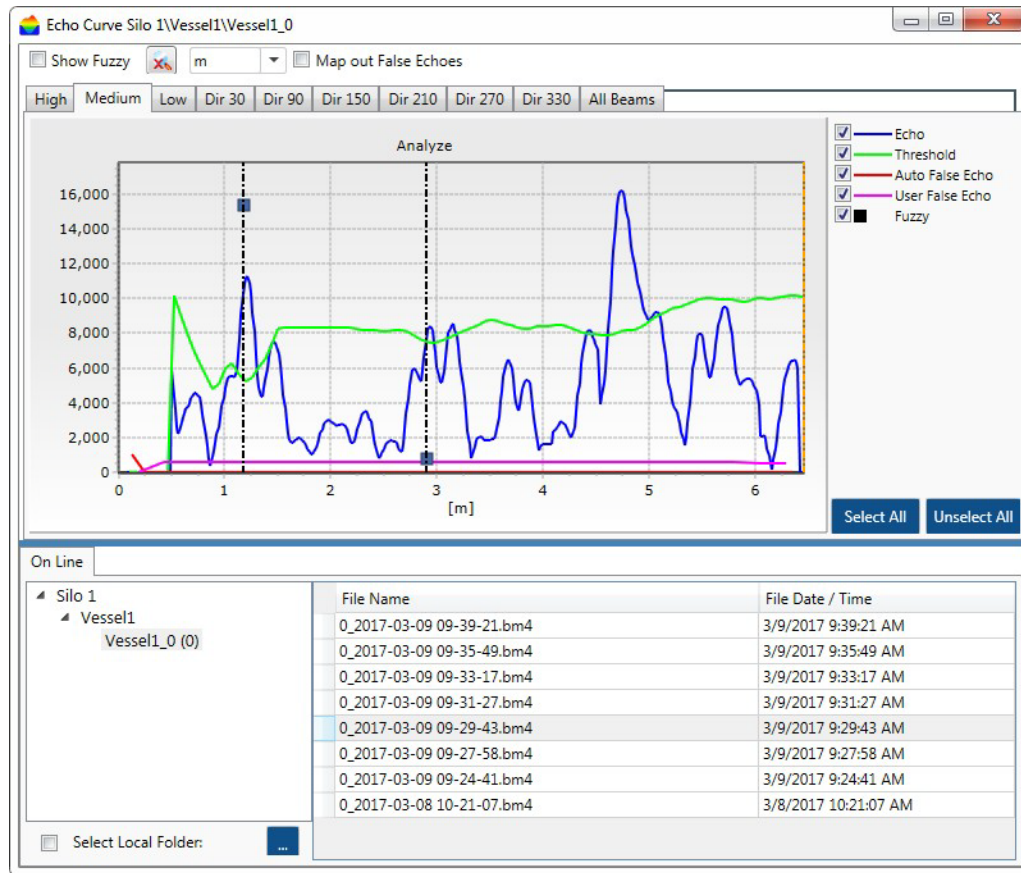

- Zoom into the area of false echoes at the first 1.5 m by clicking and dragging down and to the right marking a square around the required area. This is done to view the exact numbers that later needed to be mapped out under the False Echo Mapping function.
- Check the *Map Out False Echoes* check box, select the required tab or beam on which you would like to perform the false echo mapping, using the mouse left click mark a rectangle around the false echo you wish to map and release the mouse button. The *Echo Mapping* window will pop up populating all relevant fields, Click **Start Scanning** to initiate the operation.
- False Echo Mapping can be also found under the Device menu. Manually scan from 0 to beyond the distance of the false echoes. In this case, the echo will be 1.6 m. Select Manual Scan, set the range of scan and the level of the threshold, in this case it can be 10000.
- Select the **Start Scanning** button.
- Once the message disappears, the False Echo Mapping process is completed. Wait a couple of minutes and perform Echo Curve Analysis again to verify the position of the User False Echo line (pink) in each of the beams the operation was done. Wait at least one damping time before the algorithm takes effect of the changes and completely ignores the false echoes.

Note

This is a brief run through of the False Echo Mapping process. There are many other situations that may call for different techniques. An improper mapping of a vessel can lead to a poor performance.

7.5.8 Device activations

This option can be reached from the menu **Device > Device Activations....**

The options under this window are:

- Devices Reset
- Update Firmware
- Com. Quality

Device reset options

Reset (Restart) Device – Sends a restart command to the device. The internal DSP boots and starts building the auto false echoes and damping values. The initialization process takes about 30 seconds. The device will perform a new search for the correct measurement.

Reset to Factory Defaults – Resets most of the system parameters to their factory default settings. All parameters must be re-defined following this operation. The following parameters remain unchanged: 'Output Damping Time' and 'Steepest Material Slope'.

Reset Advanced Parameters and False Echoes – Resets all advanced parameters. This function will not reset the 'Output Damping Time', 'Steepest Material Slope', 'Max. Capacity', 'Max. Emptying Rate' and 'Max. Filling Rate'. Device configurations set in the Configuration Wizard will not restore to factory defaults.

Select the device(s) from the tree view on the left side and check the required option, select **Reset** to commence the operation.

Figure 7-75. Device Activation - Reset Options

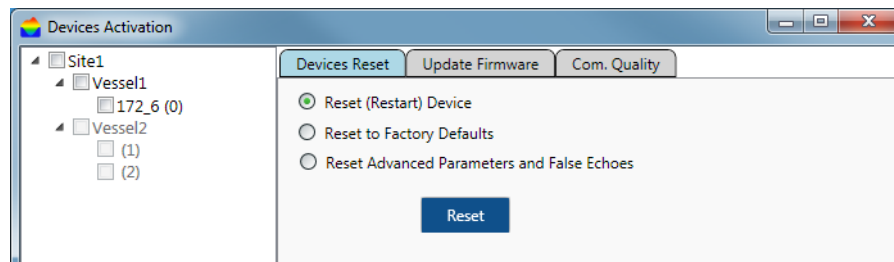

Firmware update

This tool allows updating the FW to one or more devices selected in the site tree view.

1. Select the device(s) you want to perform the Firmware update using the check-boxes on the left side.
2. Select the ... button to select the firmware file, it should be a file with extension .ldr.
3. Select the **Start Update** button to initiate the operation.

The firmware update will be performed on one device at a time.

Once all devices have been updated, a pop-up window with hardware inventory will pop up and show the current FW version of all the devices. Wait until all fields are filled to verify operation.

Figure 7-76. Firmware Update

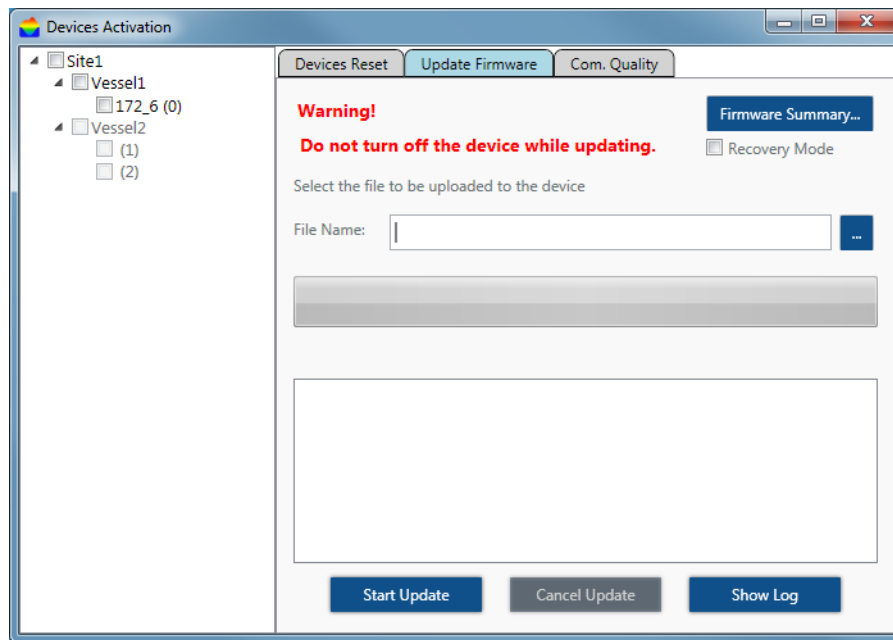

Communication quality test

The communication quality test tool tests the connection quality between the computer and the selected device(s). If packets not answered, or received with errors, there is an indication in the results log.

In cases where the quality is not 100 percent, it is recommended that the RS-485 cable is to be checked for existence of proper resistors on both sides and verified to be of shielded and twisted-pair type and that the cable is designed for RS-485 communication protocol.

An example for a good test result: an average delay of 97msec (very low), no lost packets and no errors received.

1. Set the number of cycles between 20 to 1000.
2. Select **Start Test** to begin the testing. The test will cycle through until terminated.
3. Select **Stop Test** to terminate the operation.
4. Select **Show Log** to open the results in a Notepad text file.

It is important to test the quality of the communication between the computer running the Rosemount 3DVision Server and the devices after initial setup and first connection.

Figure 7-77. Communication Quality Test

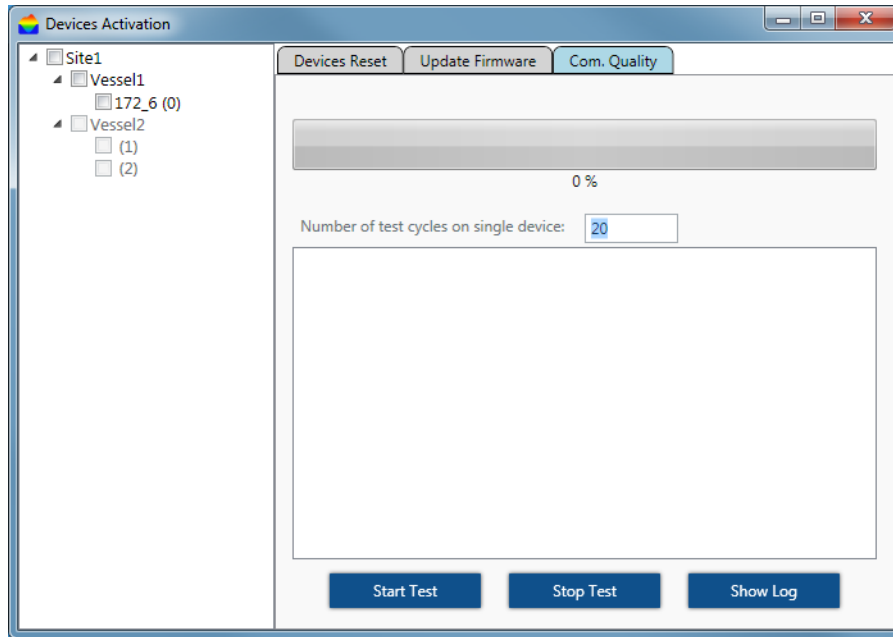

7.5.9 Model upgrade

Upgrading a model is available for Rosemount 5708L and 5708V to Rosemount 5708V or Rosemount 5708S

7.5.10 Reports Wizard

Report Wizard

On the *Tools* menu, select **Reports Definition Wizard** to access the report options or click **F9** to open the *Reports Wizard*.

- Two report types available:
 - Inventory report
 - On Line report
- Define contacts, setting Email and SMS parameters available on report configuration window (Bottom left button).
- On contacts tab user can edit contacts details.
- Mail setup parameters must be entered in order to receive email notification.
- SMS setup parameters.

Inventory report

1. Step 1 - Report Type

- On first activation, user should select the <Template_Report> and continue to next steps definitions. On last step, user required to save the settings to new name (for ex. "Automation default report").
- Running immediate report is available by selecting report and press the Run button.
- Rename and delete reports is possible to non-template report only.

Figure 7-78. Report Type

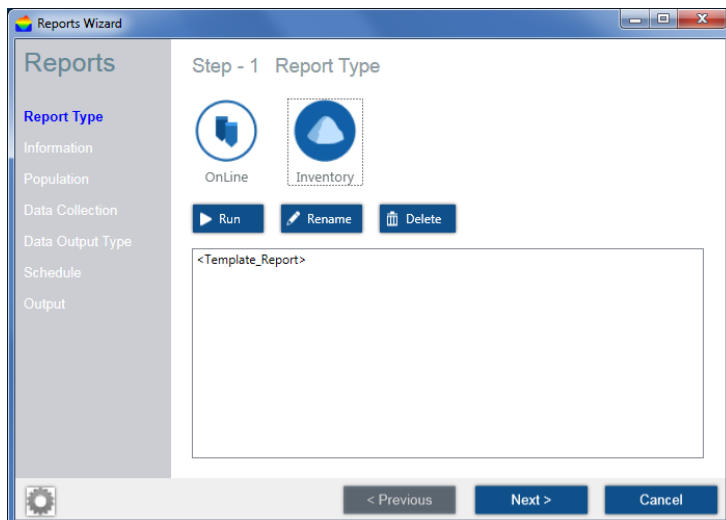

2. Step 2 - Information

- User able to define if current report will be active or not, by Active check box.
- Title and Description fields are just informative fields for step 2 and doesn't go out to report information.
- Excel report file name define on File Name field.
- Output Header fields are informative fields, which display on report file.

Figure 7-79. Information

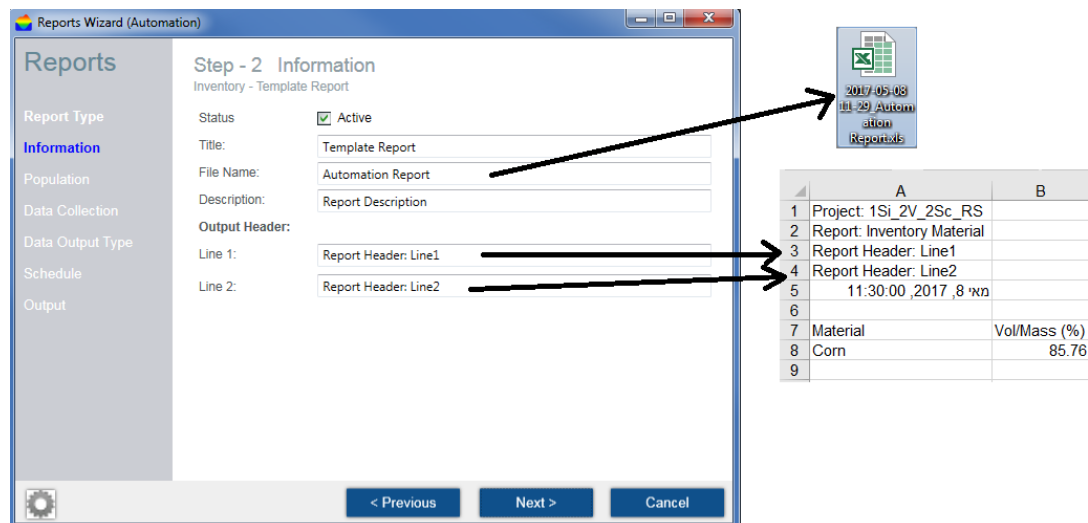

3. Step 3 - Population

- Choose which vessels will be included on report.
- Selection may be made by material type (select material and press Apply).

Figure 7-80. Population

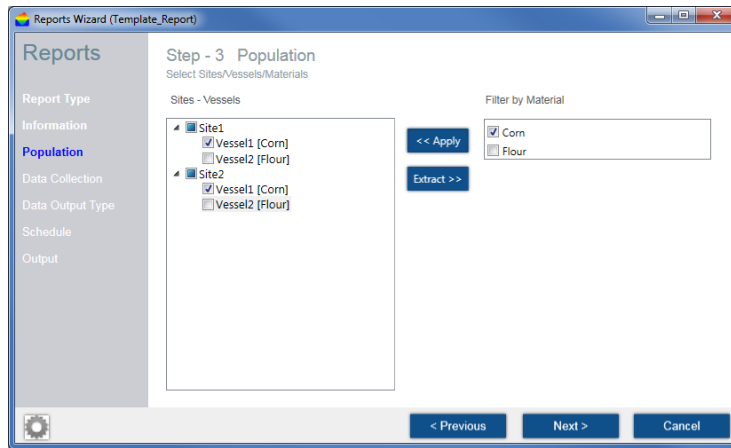

4. Step 4 - Data Collection

Select which measurements will be included on report.

Figure 7-81. Template_Report

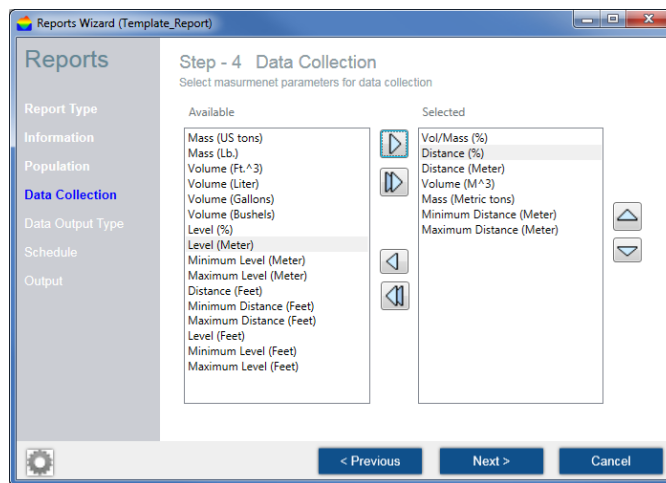

5. Step 5 - Data Output Type

Five data output types are available:

1.1 Periodic Site Vessel

- a. Create separate report file for each site, according to population selection (step 3).
- b. Single report contains all schedule measurements according to schedule settings - step 6.

Figure 7-82. Periodic Site Vessel

Step - 5 Data Output Type

Select report type and review report example

Report Data Output Type

- Periodic Site Vessel
- Periodic Vessel
- Sum Total Material Project
- Sum Total Material Site
- Sum Total Material Site Vessel

Report output display example [Periodic Site Vessel]

Project: 2Si_2V_2Sc_RS
Report: Inventory Periodic Site
Report Header: Line1
Report Header: Line2
Site:Site1

		Vol/Mass (%)	Distance (%)	Distance (Meter)	Volume (M^3)	Mass (Metric tons)
Vessel1(Corn)	00:00:00 ,2017 ,8 WTD	87.75	20.30	6.09	25967.01	12983.50
Vessel2(Flour)	00:00:00 ,2017 ,8 WTD	84.27	23.03	6.91	24936.82	12468.41
Vessel1(Corn)	01:00:00 ,2017 ,8 WTD	87.75	20.30	6.09	25967.01	12983.50
Vessel2(Flour)	01:00:00 ,2017 ,8 WTD	84.27	23.03	6.91	24936.82	12468.41
Vessel1(Corn)	02:00:00 ,2017 ,8 WTD	87.75	20.30	6.09	25967.01	12983.50
Vessel2(Flour)	02:00:00 ,2017 ,8 WTD	84.27	23.03	6.91	24936.82	12468.41

2.1 Periodic Vessel

- a. Create a separate report file for each Vessel, according to population selection (step 3).
- b. Single report contains all schedule measurements according to schedule settings - step 6.

Figure 7-83. Periodic Vessel

Step - 5 Data Output Type

Select report type and review report example

Report Data Output Type

- Periodic Site Vessel
- Periodic Vessel
- Sum Total Material Project
- Sum Total Material Site
- Sum Total Material Site Vessel

Report output display example [Periodic Vessel]

Project: 2Si_2V_2Sc_RS
Report: Inventory Periodic Vessel
Report Header: Line1
Report Header: Line2
Site:Site1
Vessel:Vessel1

	Vol/Mass (%)	Distance (%)	Distance (Meter)	Volume (M^3)	Mass (Metric tons)
00:00:00 ,2017 ,8 WTD	87.28	20.68	6.20	25825.97	12912.99
01:00:00 ,2017 ,8 WTD	87.28	20.68	6.20	25825.97	12912.99
02:00:00 ,2017 ,8 WTD	87.28	20.68	6.20	25825.97	12912.99
03:00:00 ,2017 ,8 WTD	87.28	20.68	6.20	25825.97	12912.99
04:00:00 ,2017 ,8 WTD	87.28	20.68	6.20	25825.97	12912.99

3.1 Sum Total Material Project

- a. Sum selected measurements for each material - for whole project according to population selection (step 3).
- b. Each scheduled report created on separated file.

Figure 7-84. Sum Total Material Project

Step - 5 Data Output Type

Select report type and review report example

Report Data Output Type

- Periodic Site Vessel
- Periodic Vessel
- Sum Total Material Project
- Sum Total Material Site
- Sum Total Material Site Vessel

Report output display example [Sum Total Material Project]

Project: 2Si_2V_2Sc_RS
Report: Inventory Material
Report Header: Line1
Report Header: Line2
15:43:21 ,2017 ,8 1ND

Material	Volume (M^3)	Vol/Mass (%)	Distance (%)	Distance (Meter)	Mass (Metric tons)
Corn	50608.86	171.03	44.12	13.24	12559.27
Flour	51113.64	172.74	42.78	12.83	12859.88

4.1 Sum Total Material Site

- a. Sum selected measurements for each material on each site.
- b. Each scheduled report created on separated file.

Figure 7-85. Sum Total Material Site

Step - 5 Data Output Type

Select report type and review report example

Report Data Output Type

- Periodic Site Vessel
- Periodic Vessel
- Sum Total Material Project
- Sum Total Material Site
- Sum Total Material Site Vessel

Project: 2Si_2V_2Sc_RS
Report: Inventory Site Material
Report Header: Line1
Report Header: Line2
16:13:23 ,2017 ,8 1ND

Site	Material	Volume (M^3)	Vol/Mass (%)	Distance (%)	Distance (Meter)
Site1	Corn	25789.72	87.15	20.77	6.23
Site1	Flour	25811.52	87.23	20.71	6.21
Site2	Corn	25326.98	85.59	22.00	6.60
Site2	Flour	25615.68	86.57	21.23	6.37

5.1 Sum Total Material Site Vessel

- a. Summarize all selected vessels measurements.
- b. Each scheduled report created on separated file.

Figure 7-86. Sum Total Material Site Vessel

Step - 5 Data Output Type

Select report type and review report example

Report Data Output Type

- Periodic Site Vessel
- Periodic Vessel
- Sum Total Material Project
- Sum Total Material Site
- Sum Total Material Site Vessel

Project: 2Si_2V_2Sc_RS
Report: Inventory Site Vessel Material
Report Header: Line1
Report Header: Line2
16:17:46 ,2017 ,8 1ND

Site	Vessel	Material	Volume (M^3)	Vol/Mass (%)	Distance (%)	Distance (Meter)
Site1	Vessel1	Corn	25463.47	86.05	21.64	6.49
Site1	Vessel2	Flour	25497.03	86.17	21.55	6.46
Site2	Vessel1	Corn	25400.81	85.84	21.80	6.54
Site2	Vessel2	Flour	25824.86	87.27	20.68	6.20

6. Step 6 - Schedule

Schedule interval options: Daily, Weekly, Monthly, One-time event.

Figure 7-87. Schedule

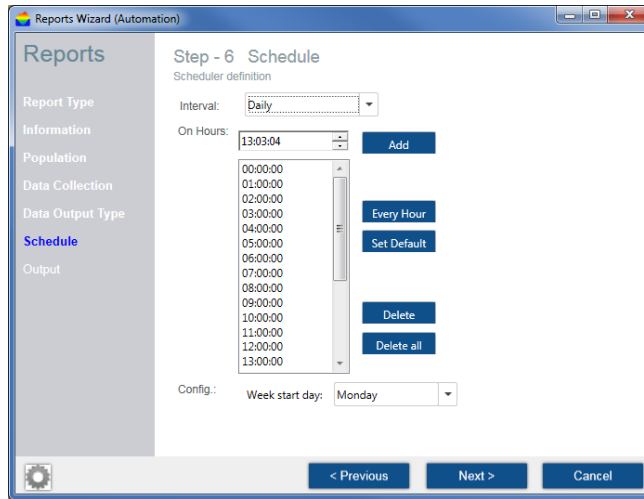

Note

Interval option just declare the directory order, where report files will save.

For example: On daily report, it will create directory every day and put all day reports into it.

Interval OptionFolder ex.

Daily

Weekly

Monthly

7. Step 7 - Status

- User can select who will get SMS and Email every time report creates.
- Define contacts information available on “Reports Wizard” on page 116.

Figure 7-88. Output

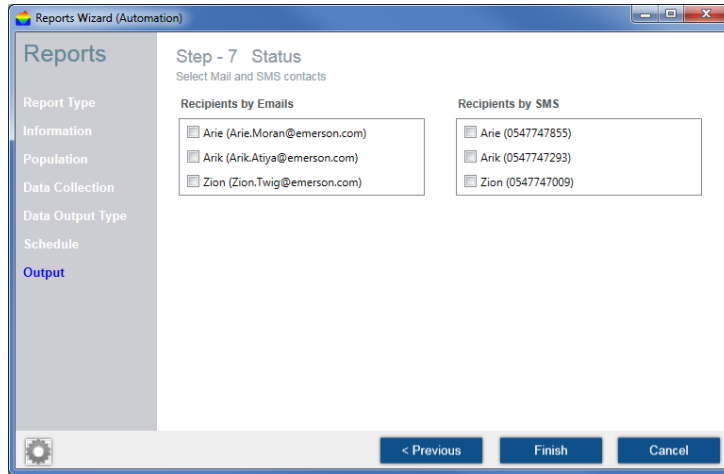

Note

User must fill in Mail setup and SMS setup information, on report configuration window, in order to use those services.

Note

SMS message includes only notification of report creation without measurements values. For Ex.: “Report Generation Wednesday, February 22, 2017 12:00:00”

Online report

Online report allows users to save measurements into file which update every interval time.

1. Step 1 - Report Type

User should select the “Online Report” and continue to next steps definitions.

Figure 7-89. Report Type

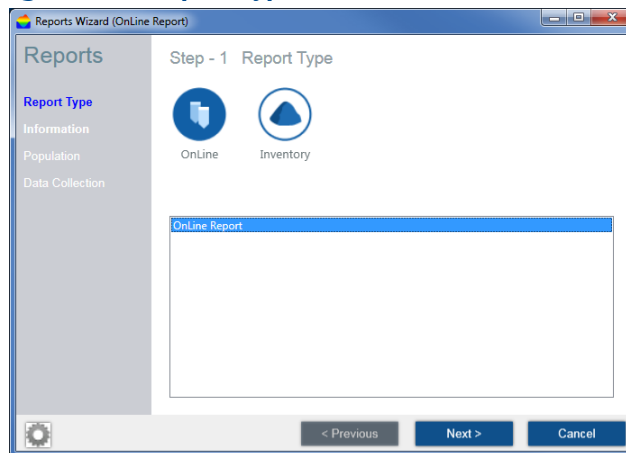

2. Step 2 - Information

- User able to define if current report will be active or not, by Active check box.
- Output file will create on the selected report folder. Measurements will update according to “Write interval” time.

Figure 7-90. Information

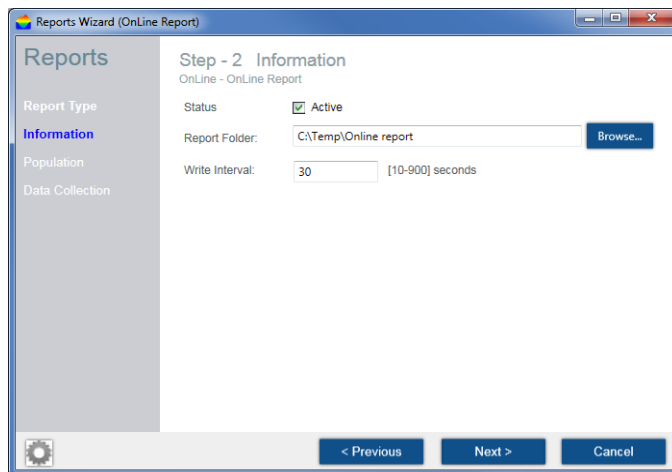

3. Step 3 - Population

- Choose which vessels will be included on report.
- Selection may be made by material type (select material and press **Apply**)

Figure 7-91. Population

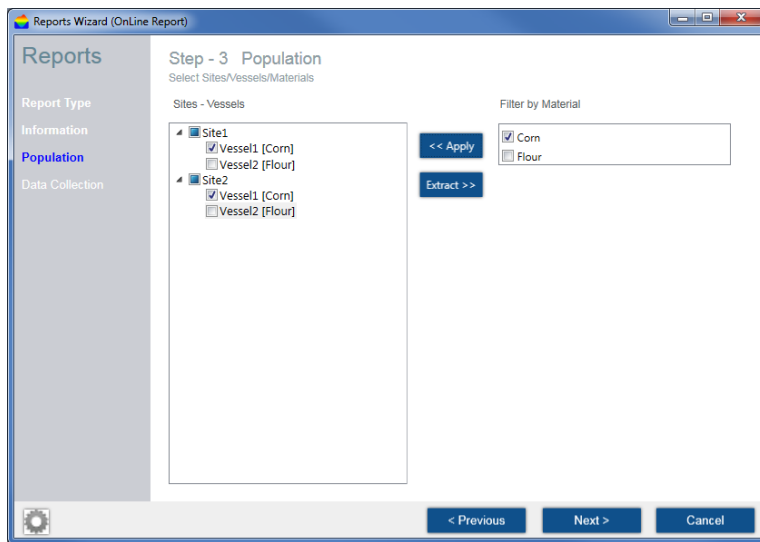

4. Step 4 - Data Collection

Select which measurements will be included on report.

Figure 7-92. Data Collection

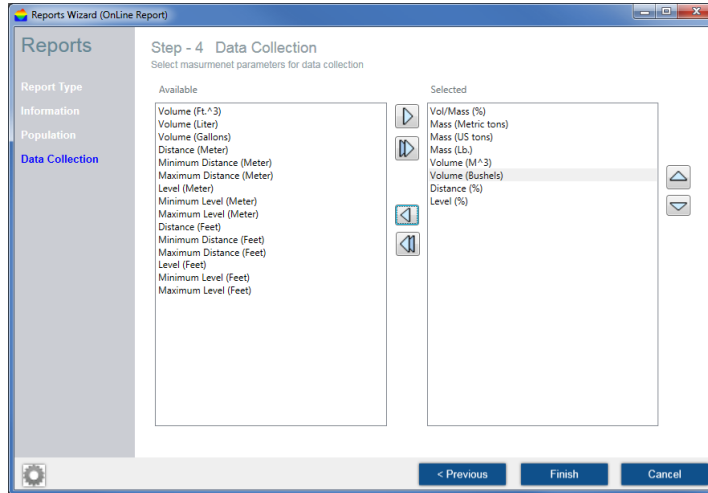

7.5.11

Event log

Figure 7-93. Event Log View

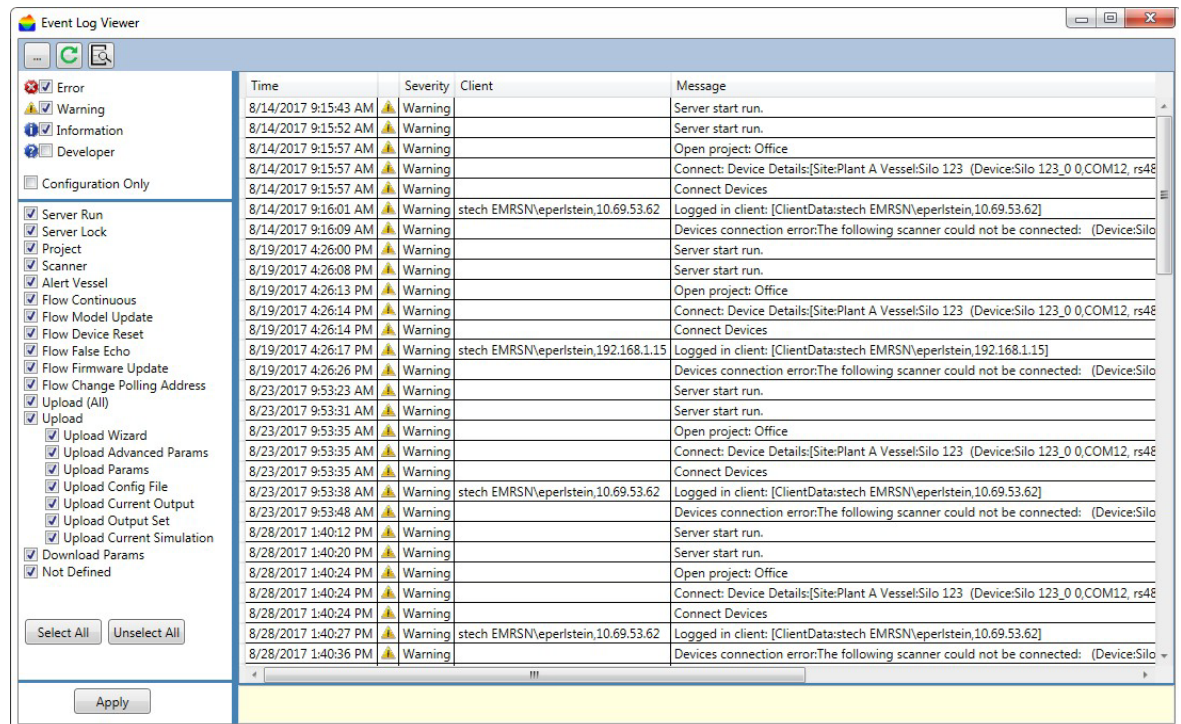

Hardware inventory table

The hardware inventory table lists the following:

- All sites included in the project with their names, descriptions, and server names.
- For each site, the included vessels are listed with their names.
- For each vessel, the devices related to that vessel are listed below it.

The table contains the following properties per the included items: Vessel, Serial Number, Hardware and Firmware versions of the devices, Polling Address, model, and Connection type, Communication Port, Chain ID and SCADA ID.

Note

SCADA ID - Each vessel gets its own SCADA ID, and each scanner has a separate SCADA ID. This allows separating measurements of scanners from the vessel in multi-scanner system.

Chain ID is used in cases where the Rosemount 3DMultiVision is connected to multiple devices over multiple chains and the user wants to connect to a specific device from the Rosemount 3DVision.

SCADA ID is assigned per vessel and used when connecting a SCADA system to retrieve the registers of the vessel.

To create a hardware inventory table:

- Select **Tools > Reports > Hardware Inventory Table**. The table opens in a separate window (Figure 7-94).

The data displayed is updated when the **Refresh** button is selected.

Figure 7-94. Hardware Inventory Table

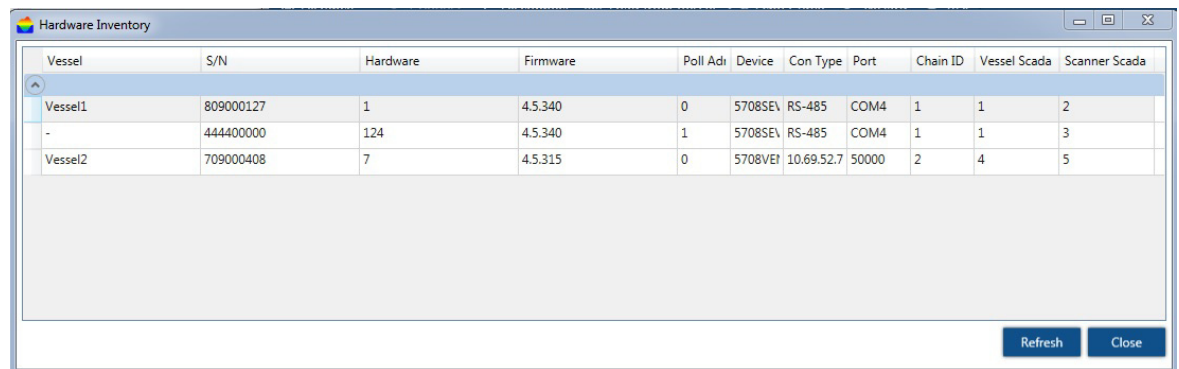

Vessel	S/N	Hardware	Firmware	Poll Adr	Device	Con Type	Port	Chain ID	Vessel Scada	Scanner Scada
Vessel1	809000127	1	4.5.340	0	5708SEV	RS-485	COM4	1	1	2
-	444400000	124	4.5.340	1	5708SEV	RS-485	COM4	1	1	3
Vessel2	709000408	7	4.5.315	0	5708VEI	10.69.52.7	50000	2	4	5

Measurement summary table

The measurement summary table lists the Volume (absolute), Volume %, Mass, and Alerts for all vessels on all sites, grouped by site.

The table lists the measurement units reported by the devices.

To activate the measurement summary table:

- Select **Tools > Reports > Measurement Summary Table**. The table opens in a separate window (Figure 7-95).
- Select the **Refresh** to update the displayed data.

Figure 7-95. Measurement Summary Table

Vessel	Volume %	Volume	Volume Unit	Mass	Mass Unit	Alert
Vessel1	-	0	m ³	0	ton	Temperature alert. Scanners:1:172_6
Vessel2	-	-	-	-	-	

Demo mode

The Demo mode is useful for demonstration and marketing purposes, and for understanding system operation.

The Demo mode loads a demo project with pre-defined sites, vessels, and devices and their configuration, and activates a simulation of filling/emptying operations over time. Most software features are available in demo mode, allowing the user to view reports, 3D visualizations, logs, and time-based charts and their behavior over time.

To initiate the Demo mode:

1. On the *Tools* menu, select **Demo > Start Demo Running**. The *Projects* window appears with a list of various demo projects, such as Aggregates, Chemicals, Food, and more.
2. Select a demo project and click **Select**. The demo project loads with all its sites, vessels, and devices, and simulation begins.

The following options are available in the **Tools > Demo** drop-down menu:

- **Stop Demo Running**: Exits the demo mode and opens a project selection box.
- **Restart Demo Running**: Brings the demo values to their initial levels and continues the simulation while keeping demo history.
- **Fast Run/Normal Run/Slow Run**: Runs the demo mode simulation at various speeds. By default, the Normal Run option is selected.
- **Reset Demo Date (Server)**: Restarts the demo mode.

Note

The demo mode must be stopped before the system can return to normal operation. Exiting and restarting the application will not stop the demo mode.

7.5.12 User management

The Rosemount 3DVision/3DMultiVision software enables several user levels. Each level has different authorizations for accessing system features. Multiple users can be added to the system and their authorization levels set.

The available user level options are:

- Administrator – Has all privileges except for changing device configuration, communication and polling address. Default user name: admin, default password: admin
- Senior Technician – Has privileges to configure all of the devices parameters including configuration wizard, advanced parameters and more. Default user name: stech, default password: techS
- Viewer – Only has viewing capabilities.

To access Users Management:

Select **Tools > Users Management**. The *Users* window opens allowing the user to add and delete users and set a user name, password, and authorization level. Only Administrator can add or remove users with different privileges.

The **Users Authorization is Enabled** check-box, when unchecked, causes the server to ignore the defined user authorizations, enabling the user to enter the system without a password and log in with administrator privileges.

Figure 7-96. Users Management

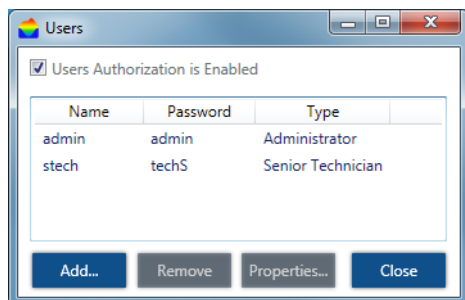

7.5.13 Material configuration

The software includes a convenient tool for managing material types which are represented by names and colors. Materials can be added to the project with their names and their colors chosen. When setting up vessels, a stored material may be selected, with its color representing the vessel.

To open the Material Configuration tool:

Select **Tools > Material Configuration**. The *Material Configuration* window opens (Figure 7-97) including the options to add, delete, or modify and store material descriptions and colors.

To add a new material:

1. In the *Material Name* box, type the new material name.
2. Select the [...] button.
3. In the *Material Color Selection* list, select the desired color. The vessel image automatically changes to display the stored material with the selected color.
4. Select the **Close** button.
5. Select **Add**. The new material is added to the list.

To edit a material:

1. In the *Available Materials* list, select the material to be modified.
2. Type a new name or select a different color and select **Edit**.

To delete a material:

In the *Available Materials* list, select the relevant material and select **Delete**.

Figure 7-97. Material Configuration

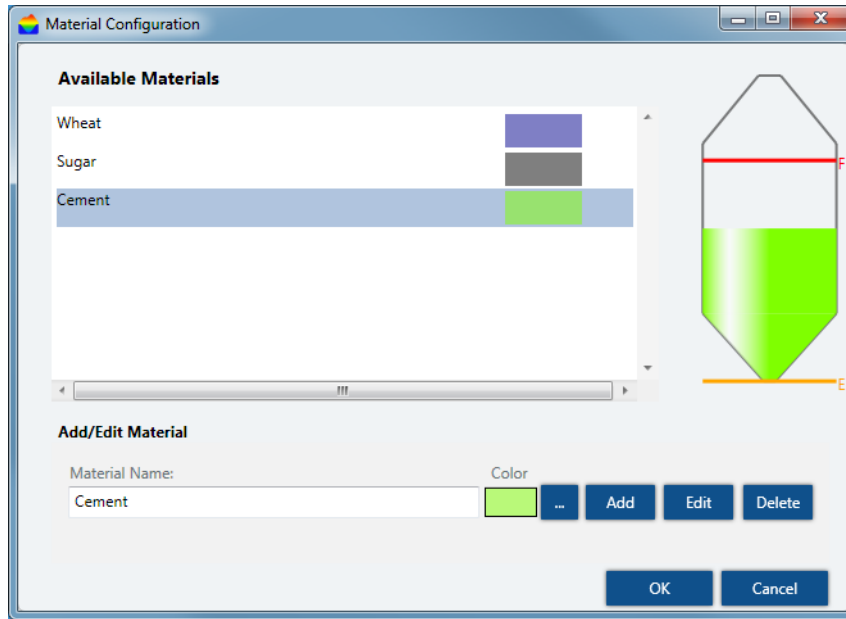

7.5.14 3D visualization

A 3D visualization of the vessel includes the device(s) located on it, the material stored, and several control options. The level and surface of the 3D visualization is shown as measured by the device(s).

To view the 3D visualization:

- Select a vessel from the vessel selection bar. The 3D visualization is displayed in the right pane of the main work area.
- OR
- Select a site and right-click on a vessel box in the main work area. Select **Show 3D Profile**. The 3D visualization opens in a new window.

The 3D visualization includes the following options:

- Navigation stick: Enables four-directional image tilt and rotate over the X and Y axes. A central home button brings the axis back to 0° position and resets the magnification.
- Magnification slider: Enables changing the image magnification in and out.
- **On line** check-box: (This only appears when viewing the 3D visualization in the main work area.) When checked, the image is displayed in accordance with the current material measurements. When unchecked, the view changes to an animation showing the stored material level and surface changes over a selectable time period (Figure 7-99).
- Play/Stop/FF/REW animation control buttons.
- Time bar with location knob.
- Interval: Sets frame rate in milliseconds.
- [↕] button: Changes the animation date range.
- [...] button: Opens an existing animation file.

Figure 7-98. 3D visualization

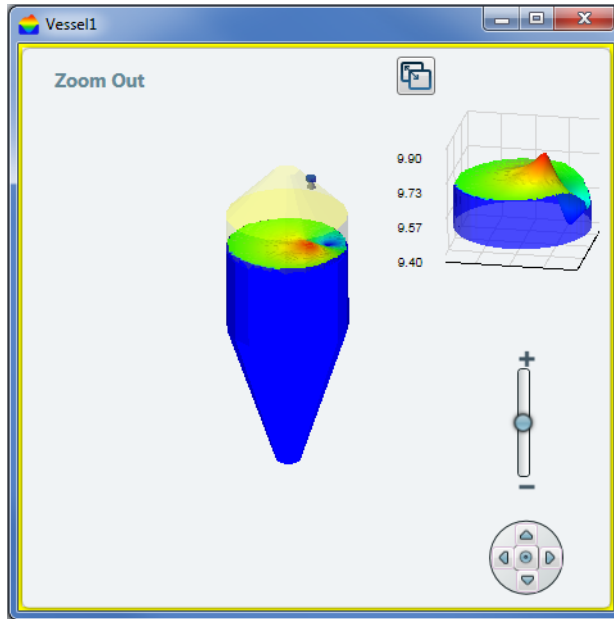

Figure 7-99. Animation Control Bar



Additional 3D visualization related functions are available by right-clicking on the image.

Figure 7-100. 3D visualization Functions

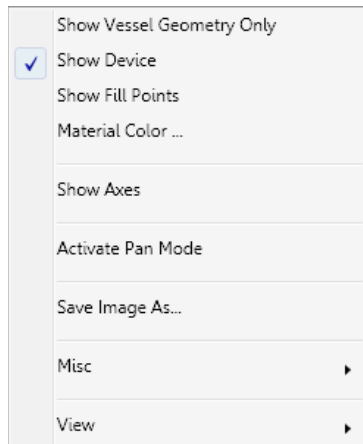

Table 7-6. 3D visualization Functions

Function	Description
Show Vessel Geometry Only	Removes the material representation leaving only the vessel shape.
Show Device	Shows the device(s) in their configured locations on the top of the vessel.

Function	Description
Show Fill Points	Adds small arrow icons to represent the location of the filling points based on the configuration.
Material Color...	Opens the Material Color Selection window to select the material color.
Show axes	Shows the user the X, Y, and Z axes.
Activate Pan Mode	Allows the user to move the 3D visualization (as opposed to rotating).
Save Image As...	Saves the current image as a JPEG file on the computer.
Misc ►	Additional functions:
Show Silo Dimension Walls	Adds grid walls with dimensions.
Show Figures	Show or hide text added in the Vessel graphic figures option.
Show Scanner Name	Displays the device's Tag Name and polling address.
Show Scanner Position	Shows the device (x, y, z) position near the device display.
Show Device Offset Holder	Shows the device neck extension/extension pipe according to the offset configured in the Configuration Wizard (step 2).
Show Full and Empty Calibration	Adds circles at the level of the full and empty calibration levels.
Draw Silo Grid (Wireframe)	Adds grid to the material surface.
Show Solid Material Color	Switches the gradient material color to a single color.
Fill Bounds With Material	Fills the bounds of material and silo with the same color as the material.
Hide Top Shape	Hides the top part of the silo in case it is a cone, dome, or pyramid
3D Algorithm Accuracy	This feature enables to have higher image resolution, but slows the process and takes time between each option.
Device Components Size	Displays the Rosemount 5708 in its actual positioning. There are four options available: Real, Relative Large, Relative Normal, and Relative Small.
View ►	Viewing the 3D visualization from different angles: <ul style="list-style-type: none"> ■ Original ■ View from Front ■ View from Top ■ View from Left ■ View from Right ■ View from Behind ■ View 3D

7.5.15 Multi-server connection

The Rosemount 3DMultiVision software includes an option to connect to multiple servers by entering their server name, address, and port number.

To receive data from a server:

1. On the *Tools* menu, select **Tools > Client Options....**
2. Select **Server Connection Mode**.
3. Select the **Multiple** button. A confirmation dialog box appears to confirm the action.
4. Select **Yes**. The client application closes and reopens with the Servers Connection window open.
5. In the top left corner of the *Servers Connection* window, select the **Advanced** check box. Additional options appear in the window (Figure 7-101).
6. Select the name and select **Add Server** to define the new server. The *Server Connection* window opens.
7. Enter the Server Name, Server Address, and Server Port. Click **Select**.
8. Select the server from the list. Select **Connect** to connect to the selected server, or **Connect All** to connect to all servers listed.
9. Select **Login Server** to login to the selected server, or **Login All** to login to all servers listed. The *Login* window opens requesting a user name and password.
10. Enter the relevant user name and password and select **Sign In**.
11. In the *Servers Connection* window, select **OK**. The Rosemount 3DVision Client application loads the data of the relevant server.

Figure 7-101. Servers Connection Window

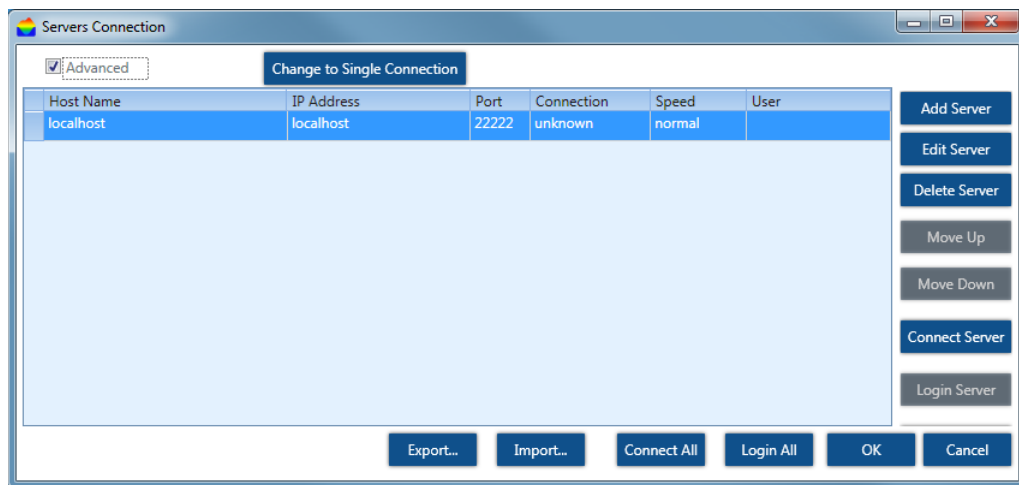

The Servers Connection window includes the following additional options:

- **Move Up/Move Down:** Allows the user to toggle between servers in the list.
- **Edit Server:** Opens a dialog box with details of the selected server.
- **Edit Server/Delete Server:** Adds, deletes, or renames an existing server from the Phone Book name List pane.
- **Export/Import:** Exports or imports .xml file.
- **Close:** Closes the client application.

7.5.16 Upgrading to Rosemount 3DMultiVision

When upgrading from Rosemount 3D Vision to Rosemount 3DMultiVision version, a license key is required. The change takes effect immediately and does not require a restart of the client PC.

1. On the *Tools* menu, select **Server Option**.
2. Select **License Key**.
3. Enter the license key and select **Apply**.

Figure 7-102. Server Configuration

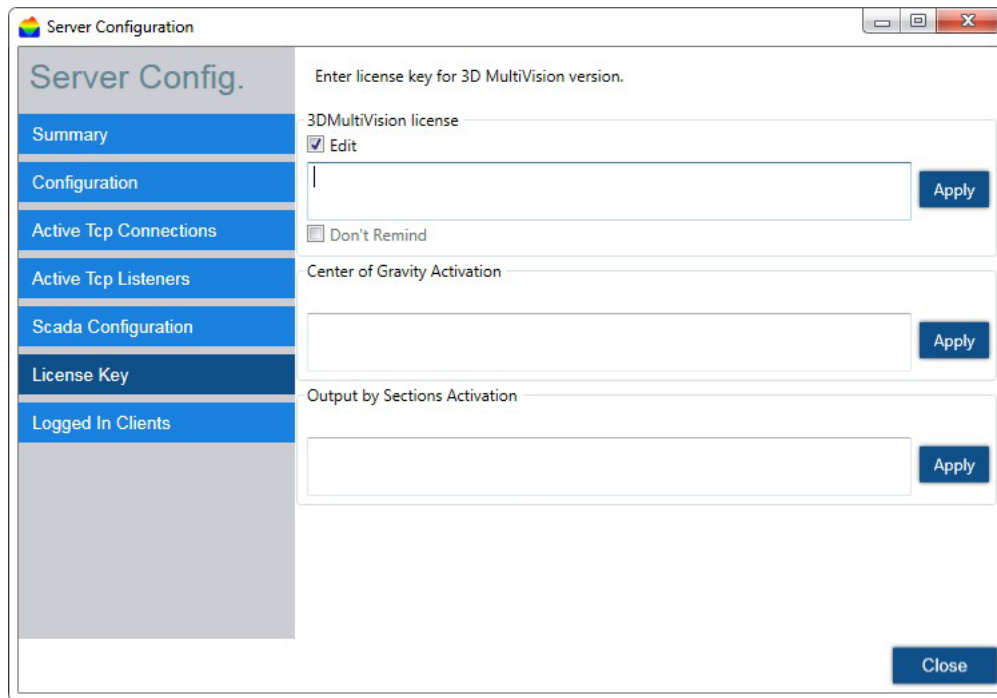

The Rosemount 3DMultiVision software may be installed and activated for up to 30 days without a license key. After 30 days, the software requires a valid license key. During the 30-day period, the software generates licensing reminder messages from time to time. Check the **Don't Remind** check-box to disable these reminders.

Note

One license code is required per application.

Advanced tools:

1. Output measurements per Section.
2. Center of Gravity Alert

Server configuration window was updated with new licenses, "Edit" checkbox appears when license already inserted.

Figure 7-103. License Key

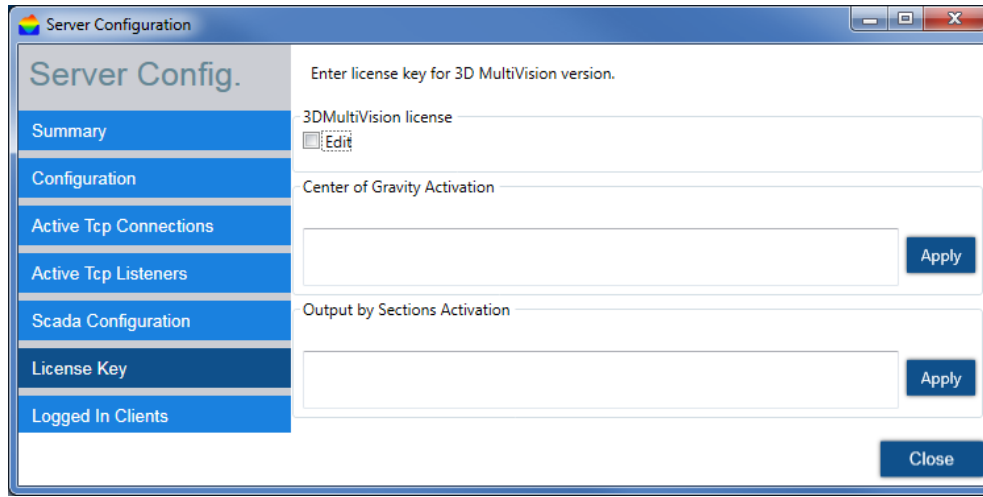

7.5.17 Center of Gravity

Center of Gravity (CoG) is a licensed option. Enter the activation code in Tools > Server Options > License Key. Click to Apply button to accept the code and close the window. See Figure 43.

Center of gravity is calculated based on the 3D image of the scanner and displayed in the 3D image. It also shows that allowed area for the CoG.

To set center of gravity, right-click the vessel when in site view mode, select Properties... and switch to the Alerts tab. See image below.

- Set the center point of the box that defines the CoG and set the box dimensions. Click **OK**.
- On the 3D image, right click and select **Show Vessel Geometry Only**. This option will remove the image of the material.
- Right click the 3D image, select **Misc** and select **Show Center Gravity**. This will show the defined box and the center of gravity point (represented with a small inverted cone) with the calculated coordinates, see Figure 109.
- In the Vessel overview, on the bottom of the measurements, the COG coordinates is added as a reference.
- When the center of gravity is outside the box, an alert will appear, see Figure 110.
- Calculated Center of Gravity coordinates can also be read via SCADA connection on Modbus registers. The holding registers are: X – 49983-4, Y – 49985-6 and Z – 49987-8. All are floating points numbers.
- To cancel the Center of Gravity, set all fields in [Figure 7-104 on page 134](#) to zero.

Figure 7-104. Center of Gravity Settings

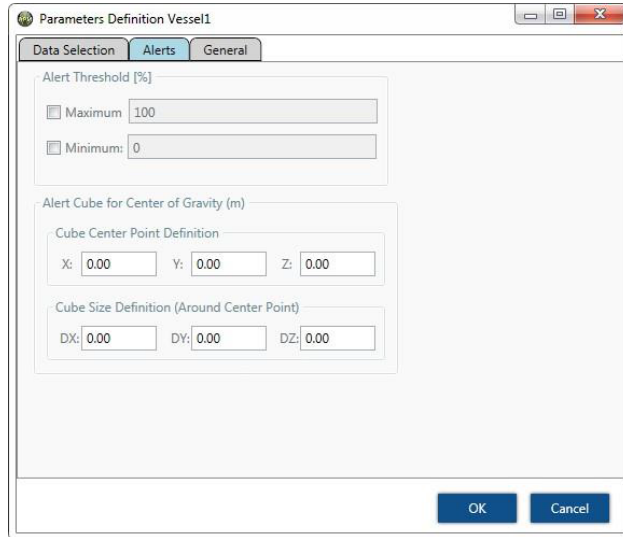

7.5.18 Level by Section Output

The option to output the level per section is licensed. Enter the activation code in Tools > Server Options > License Key. Click to Apply button to accept the code and close the window.

By activating this feature the 3Dvision can output the minimal, maximal, and average level in each section. The level in each section is calculated from the 3D image of the material in the vessel and displayed in the 3D image.

To set the Sections, right-click the vessel when in site view mode, select Properties... and switch to the General tab, see [Figure 7-105 on page 135](#).

1. Set the number of sections on X axis and the number of sections on Y axis; the total number of sections is equal to X * Y and limited to 99 sections. Set the number of sections to 1 in order to deactivate this feature.
2. Minimal size of a section cannot be smaller than 5ft. × 5ft. (1.5m × 1.5m).
3. Right -click the 3D image, select Misc and select Show Sections. This will show the grid of sections on top of the 3D image. See Figure 109 for an example of six sections.
4. Calculated section levels can also be read via SCADA connection on Modbus registers. The holding registers are:
 - 41001 – Sec 1 Avg. Level
 - 41003 – Sec 1 Min Level
 - 41005 – Sec 1 Max Level
 - 41021 – Sec 2 Avg. Level
 - 41023 – Sec 2 Min Level
 - 41025 – Sec 2 Max Level
 - 41041 – Sec 3 Avg. Level
 - 41043 – Sec 3 Min Level
 - 41045 – Sec 3 Max Level

5. All are floating points numbers.
6. An additional integration option can be done by creating a file holding the data and updated upon request. To set the file's path, see Figure 42 on page 38. The file is generated on the Server Computer. To update the file, invoke a Modbus read request to register 49981. See an example of output file in Figure 7-107 on page 136.

Figure 7-105. Section Settings

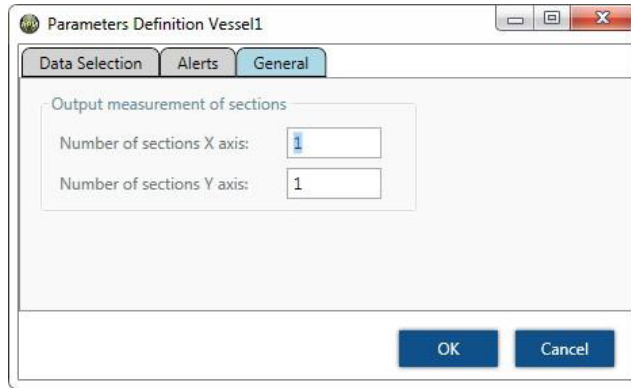

Figure 7-106. Virtual Sections

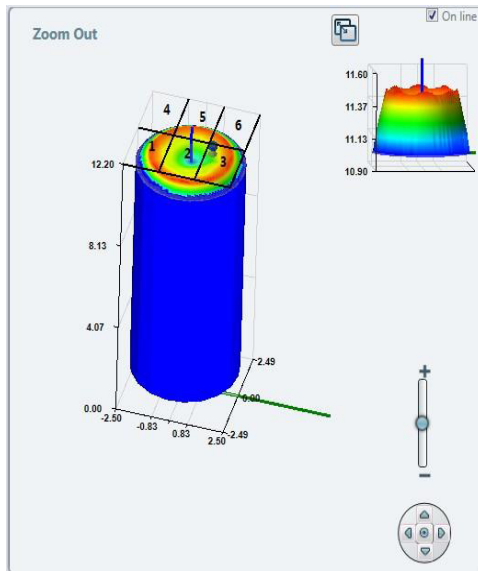

Figure 7-107. Example of Sections Output to a File

	A	B	C	D	E	F	G	H
1	Section	Avg. Level (m)	Min. Level (m)	Max. Level (m)	X Left Top	Y Left Top	X Right Bottom	Y Right Bottom
2	1	4.559	4.283	4.798	-3	-3	-1.8	-1.5
3	2	4.63	4.283	4.953	-1.8	-3	-0.6	-1.5
4	3	5.122	4.871	5.426	-0.6	-3	0.6	-1.5
5	4	5.397	5.223	5.617	0.6	-3	1.8	-1.5
6	5	5.531	5.408	5.624	1.8	-3	3	-1.5
7	6	4.911	4.583	5.133	-3	-1.5	-1.8	0
8	7	4.943	4.503	5.52	-1.8	-1.5	-0.6	0
9	8	5.493	4.875	5.917	-0.6	-1.5	0.6	0
10	9	5.786	5.46	6.031	0.6	-1.5	1.8	0
11	10	5.824	5.564	6.033	1.8	-1.5	3	0
12	11	5.219	5.122	5.338	-3	0	-1.8	1.5
13	12	5.462	5.133	5.918	-1.8	0	-0.6	1.5
14	13	5.991	5.52	6.5	-0.6	0	0.6	1.5
15	14	6.252	5.917	6.588	0.6	0	1.8	1.5
16	15	6.182	5.875	6.56	1.8	0	3	1.5
17	16	5.289	5.256	5.336	-3	1.5	-1.8	3
18	17	5.583	5.286	5.937	-1.8	1.5	-0.6	3
19	18	6.304	5.777	6.866	-0.6	1.5	0.6	3
20	19	6.676	6.382	6.922	0.6	1.5	1.8	3
21	20	6.414	6.296	6.571	1.8	1.5	3	3
22								

Note

One license code is required per 3DVision Server installation.

Section 8 Configuration - Rosemount 5708 in a System

System overview and components	page 137
Rosemount System Controller advantages	page 139
System requirements	page 140
Mounting the Rosemount System Controller	page 141
Advanced commissioning steps	page 142

8.1 System overview and components

The system of multiple Rosemount™ 5708 has been specially designed for wide silos, open bins, and warehouses where the diameters or areas to cover are exceptionally large.

The system consists of multiple Rosemount 5708S units mounted in a manner allowing the devices to cover the whole area with high accuracy.

The system is comprised of Rosemount 5708 and an industrial computer-based Rosemount System Controller, enclosed in a metal cabinet with direct RS-485 connection to the devices.

The Rosemount System Controller is comprised of a lockable metal cabinet which contains:

- Industrial computer unit
- Four-port terminal block for wiring
- Two M25 cable glands for cables insertion
- Grounding screw

Figure 8-1. Components of a Rosemount System Controller

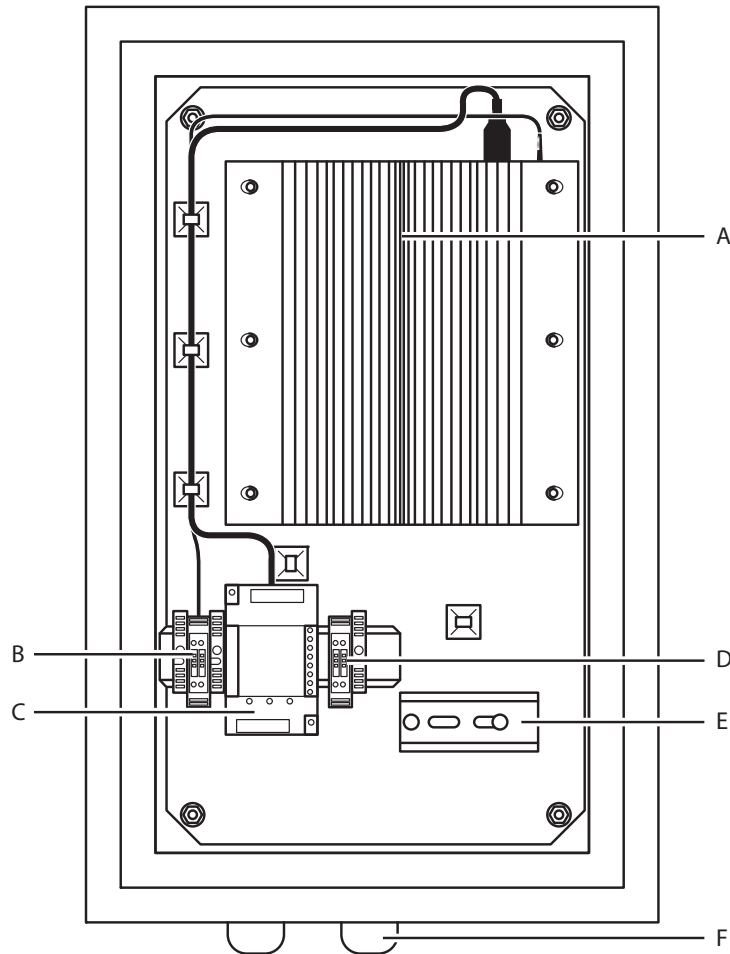

- A. Rosemount System Controller computer
- B. Power supply terminals, one for +24 Vdc, two for -24 Vdc (or GND)
- C. USB to RS-485 converter
- D. RS-485 terminals, three for D+, four for D-
- E. Spare DIN rail for other components as 24 V power supply, barriers, etc.
- F. Two M25 cable glands

Figure 8-2. Rosemount System Controller - Computer Front View

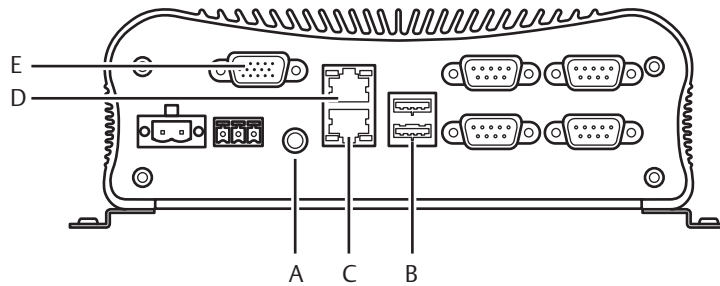

- A. Speaker out
- B. Two USB ports
- C. Ethernet #2 port - set to fixed IP Address: 192.168.99.99
- D. Ethernet #1 port - set to dynamic IP Address
- E. VGA port for external display

8.2 Rosemount System Controller advantages

The Rosemount System Controller features several major functions which bring a synergetic quality to the multiple devices positioned in the same bin:

- Synchronizes device transmissions while preventing mutual device interference
- Keeps signal-to-noise ratio performance uncompromised
- Takes into account returned echoes from all devices in the system
- Generates a complete, merged 3D visualization of the entire bin
- Updates and synchronizes 4-20mA outputs of all devices to the overall content percentage, requiring only one Rosemount 5708 to be connected to the control room.
- The accurate, timed inventory monitoring enables material ordering to meet production needs, avoiding costly emergency fills.

8.3 System requirements

Figure 8-3. Multiple Rosemount 5708 Connection

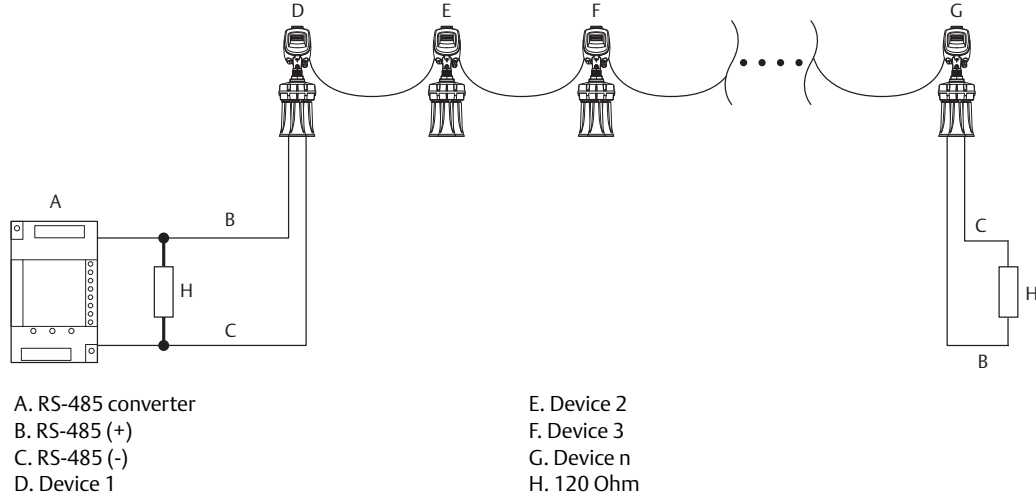

All devices must be daisy-chained with a power supply and RS-485 links to the Rosemount System Controller. A single 4-20mA pair must be wired from only one of the chained devices to the PLC/DCS/SCADA/Etc. The 4-20mA may be connected to any of the devices.

The Rosemount System Controller cabinet must be installed indoors, mounted on a wall, and wired to the devices and a power supply for the computer operation. A single 24 Vdc power supply is recommended for powering the computer and the devices. Consider power consumption as well. The computer is rated 40 W with 24 Vdc power supply, and each device is rated 1.5 W with the same power supply.

8.4 Mounting the Rosemount System Controller

The Rosemount System Controller metal cabinet is designed for wall mounting using four screws. The mounting location should be selected with considerations of the cabinet size and providing enough space allowing the door to open to the right.

Figure 8-4. Metal Cabinet - Mounting Holes for Wall Mounting

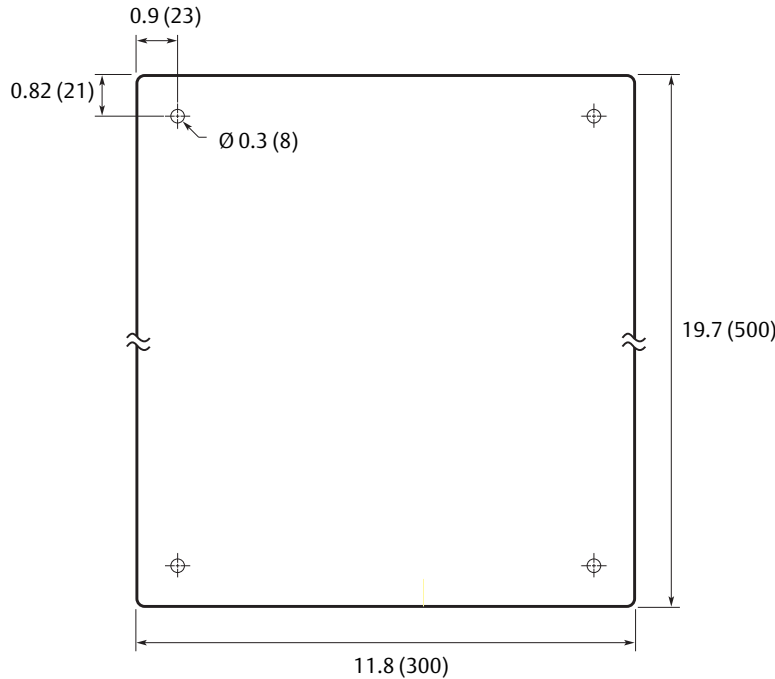

Dimensions are in inches (millimeters).

Note

A readily accessible disconnect device (such as two-pole) switch or circuit breaker rated minimum 60 Vdc/5A, marked with ON and OFF position and compliant with IEC 60947-1, IEC 60947-3, should be added externally to the Rosemount System Controller cabinet to disconnect “+” and “-” of the supply circuit.

⚠ WARNING

Protection provided by the equipment can be impaired if used in a manner not specified by the manufacturer.

⚠ CAUTION

Risk of explosion if battery in PC is replaced by an incorrect type. Replace only with the same type or manufacturer.

Note

When installing the supply and data wiring, the wiring must be properly fixed in place (e.g. by tie wraps and additionally by the cable glands) to be sufficiently resistant to undesired pull.

8.5 Advanced commissioning steps

When the system is operating and providing measurements, the Rosemount System Controller is used for running the Rosemount 3DVision Server application that synchronizes and merges the devices and delivers data to the Rosemount 3DVision Clients. It is also recommended to use the Rosemount System Controller computer for configuration and adjustments, and for executing the Rosemount 3DVision installed in it.

The recommended method of operation and steps to be taken during the installation of multiple Rosemount 5708 in a system are detailed below in chronological order:

Step 1. Rosemount 5708 installation

- Make sure all required documentation is available: Application Evaluation Form (AEF) and Vessel Drawings.
- Compare Locator suggestion or mounting location as suggested by Emerson™ with the actual Rosemount 5708 mounting positions.
- Perform manual measurements of the vessel dimensions, and compare results with the drawings.
- Check 24 Vdc input to all devices.
- Check RS-485 link between devices and the Rosemount System Controller. Make sure the resistance between D+ and D- is $60 \pm 5\%$ Ohm.
- Check 4-20 mA connection to the local PLC. Perform current simulation from the device connected to the PLC.
- Power up all devices and check polling addresses.
- Set polling addresses, make sure each device has a different polling address and one of the devices is set with polling address of 00. See [Section 6: Configuration - Rosemount 5708V and 5708S](#) for more information.
- Write down the polling addresses on the vessel drawings for all devices.
- Verify all devices for proper functioning after power up. This can be verified by connecting each Rosemount 5708 directly to a computer.
- Verify sound signal transmission from all devices.
- Get material status (level/distance/volume) according to the process manager .
- Complete all required information from the process manager in order to complete the Rosemount 5708 configuration.

Step 2. The Rosemount System Controller

- Mount the Rosemount System Controller cabinet indoors. Ensure it is accessible for power supply, Internet connections and for maintenance.
- Verify proper connection of the Rosemount System Controller to a proper power supply.
- Connect the provided crossover Ethernet cable (Ethernet port #2) from the Rosemount System Controller to a local laptop or other computer.
- Set the IP Address on the laptop to static IP: 192.168.99.xx (where xx can be any number between 001 to 255 except 099) and subnet mask 255.255.255.0. Do not forget to restore to previous state once installation is complete.
- Install UltraVNC version 1.0.8.2 on the laptop.
- Using the UltraVNC Viewer, take control over the Rosemount System Controller using IP address 192.168.99.99 and password 'admin'. It is recommended to use UltraVNC version 1.0.8.2.
- Make sure the Rosemount System Controller is installed with the latest SW version of Rosemount 3DVision. If it is not, download the required latest versions from the website or contact the local Emerson representative for further assistance.

Step 3. Rosemount 3DVision and Rosemount 5708 configuration

- Execute Rosemount 3DVision and connect to all devices using RS-485 (or TCP/IP, according to the actual connection) in multiple mode.
- If the converter's serial COM port used for the USB-to-RS-485 converter connection is not found automatically, locate it manually using the computer Device Manager.
- Verify latest firmware version and proper connection for all devices.
- Configure the first device and save the configuration file.
- Proceed with the configuration for the rest of the devices (or by uploading the first device configuration and changing the name tag, device location, device horizontal angle, and setting the full and empty calibration levels accordingly).
- Specifically check the full and empty calibration levels.
- Perform echo curve analysis for all devices and verify correct readings. Map false echoes, fine tune and adjust as needed.

Step 4. Rosemount 3DVision Clients

- Connect the Rosemount System Controller to the local area network using Ethernet port #1
- Request local IT to ensure the following TCP Ports are open and will not be blocked by any firewall or antivirus in the local network: 22220, 22221, 22222, and 22223.
- Configure the network card to a static IP address provided by the local IT. Take note of the Rosemount System Controller IP address - it will be required for all additional Rosemount 3DVision Clients.
- Install Rosemount 3DVision Client on all required computers on the same local area network (LAN) or consult with the local IT regarding the method of connection.
- Establish a connection to the Rosemount 3DVision Server from the Rosemount 3DVision Client running on the local PC using the Server IP address of the Rosemount System Controller IP written beforehand.
- Ensure the system and the vessel are connected.

Section 9 Service and Troubleshooting

Maintenance	page 145
Log views	page 146
Removing the Rosemount 5708 head	page 150
Changing the Rosemount 5708 antenna	page 151
Diagnostic messages	page 152
Parameters and alerts	page 152
Service support	page 155

9.1 Maintenance

9.1.1 Preventive maintenance procedure

The following periodic maintenance procedure is recommended for keeping the Rosemount™ 5708 in proper operating conditions and preventing unnecessary malfunctioning which may be caused by environmental factors during time:

- Clean the interior part of the antennas (see details below).
- Visually check and ensure the communication and power cables are in good condition and are not damaged.
- Check and ensure proper sealing of cable entry openings.
- Open the rear side of the Rosemount 5708 head and ensure absence of wetness.

Antenna cleaning guidelines:

- Disconnect power to the Rosemount 5708.
- Disassemble the mounting plate and carefully pull out the entire Rosemount 5708.
- Use a brush or wet cloth for the purpose of cleaning.
- As necessary, water can be used for cleaning.
- Avoid usage of sharp tools such as screwdrivers for cleaning. Such tools may damage the membranes.
- Avoid strong air purge or direct water current on the membranes.

9.1.2 Preventive maintenance frequency

The frequency of the maintenance procedure is subject to the conditions and the type of material stored in the vessel. In the case of materials such as salt, sugar, calcium carbonate, etc., treatments should be more frequent.

9.2 Log views

When a site or a vessel is selected and its properties are shown in the main work area, select the **Logs** tab to view its logs. The main work area displays logged data in historical chart representation for both site and vessel (see Figure 9-1 and Figure 9-2).

Figure 9-1. Site Logs (Demo Run Example)

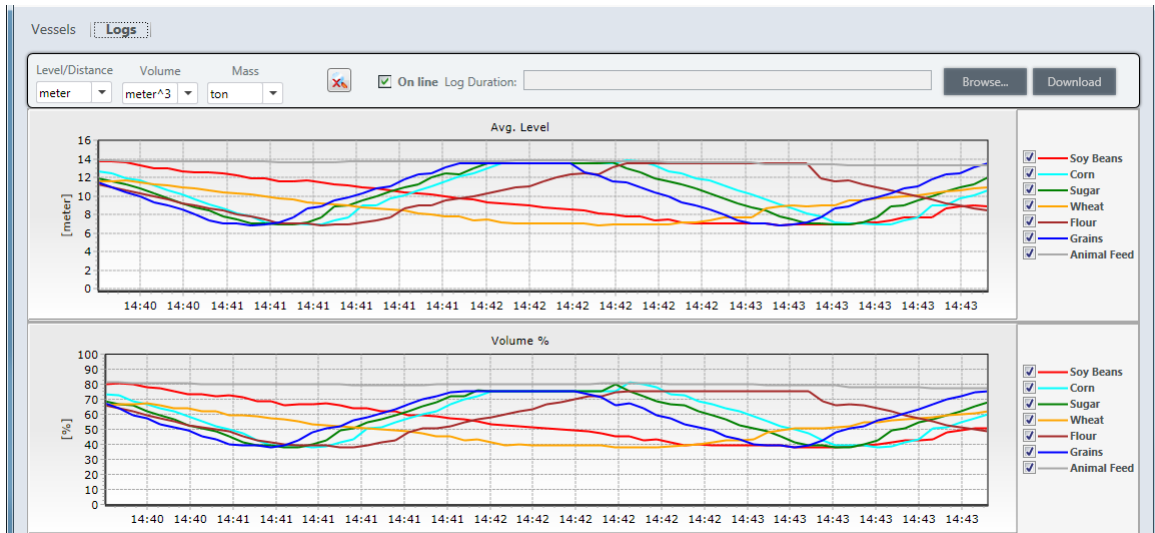
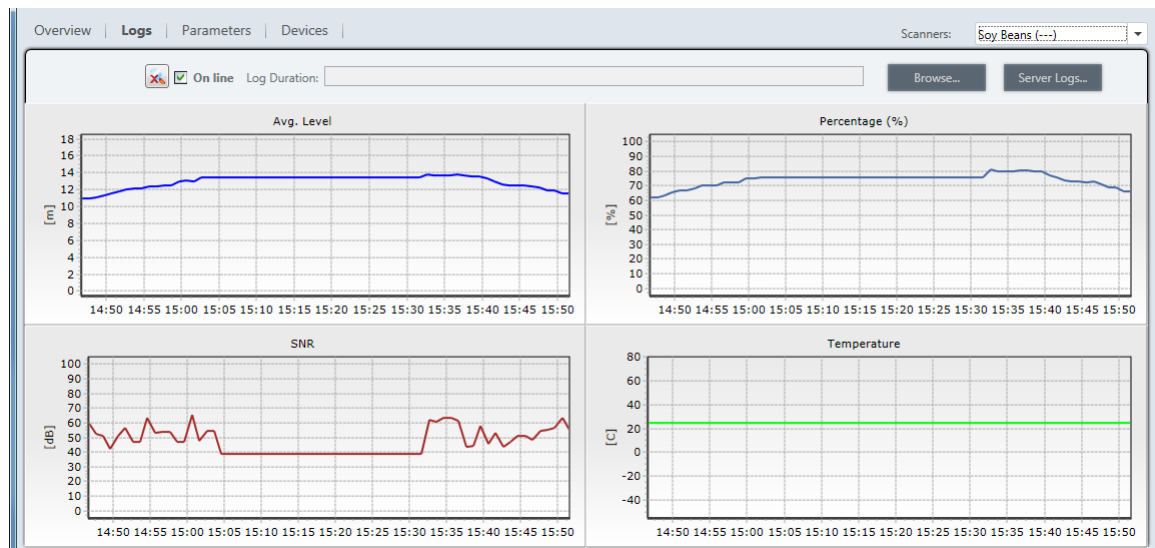

Figure 9-2. Vessel Logs (Demo Run Example)



Collected data is displayed on one, two, three, or four charts in online mode and continuously updating the charts or over a selected time period. Available options are Level, Volume, Volume %, Mass, SNR and Temperature of the selected vessel or site. SNR and Temperature cannot be viewed in Vessel mode.

To select the charts for display, click the sprocket icon. The Charts Layout Setup window opens. In each field select the desired chart to display and select **OK**.

To magnify a selected area in the chart, click and drag over the chart creating a rectangular area. Release the mouse button to magnify the chart in accordance with the selected area.

To pan a specific location in the chart, right-click inside the chart and drag. The chart area pans in accordance with the dragging location.

To cancel all zoom and pan activations applied on all graphs and return the display to the original view, select .

9.3 Vessel Data Collection (VDC)

In order to simplify the data collections on a selected vessel for troubleshooting the Rosemount 5708, a simple data collector process was developed by clicking a single button.

1. Select the VDC button. A dialog box will pop up asking to fill required details. All fields are mandatory and recommended to be filled in order to provide better service.

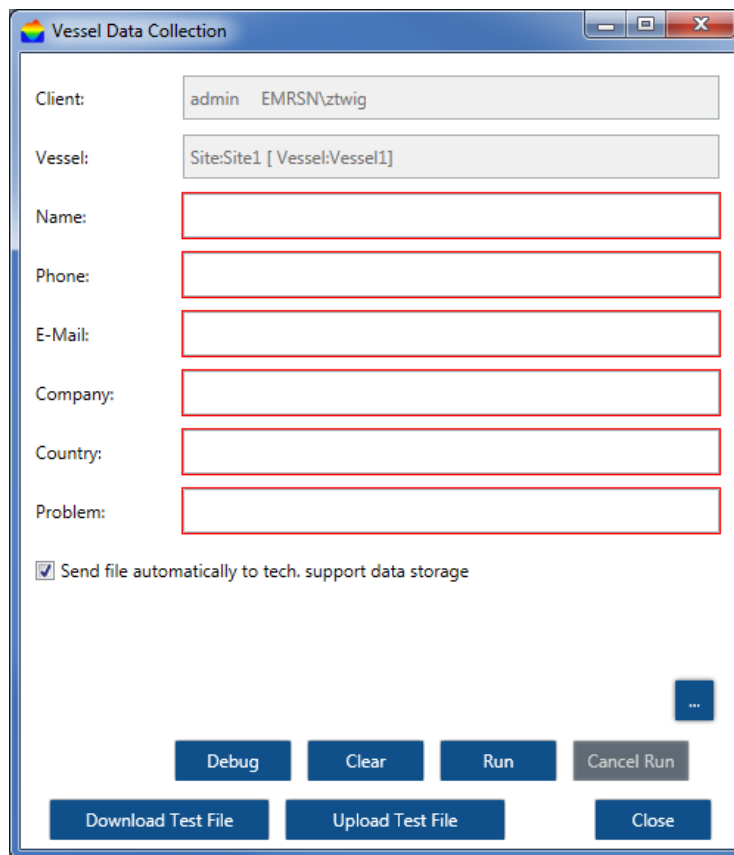

2. Check **Send file automatically to tech. support data storage** if the computer is connected to the Internet. If you choose not to send the file automatically, only the VDC zip file will be created on server local drive.
3. After data collection is completed, a link to the local folder where the zipped file located in will appear and the file can be sent in a different method.

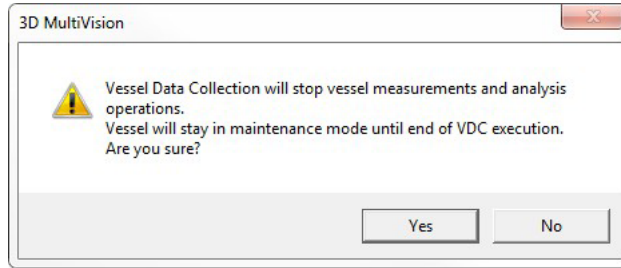

4. Select **Yes** to continue.
5. Initiating the data collection will change the window to image below.

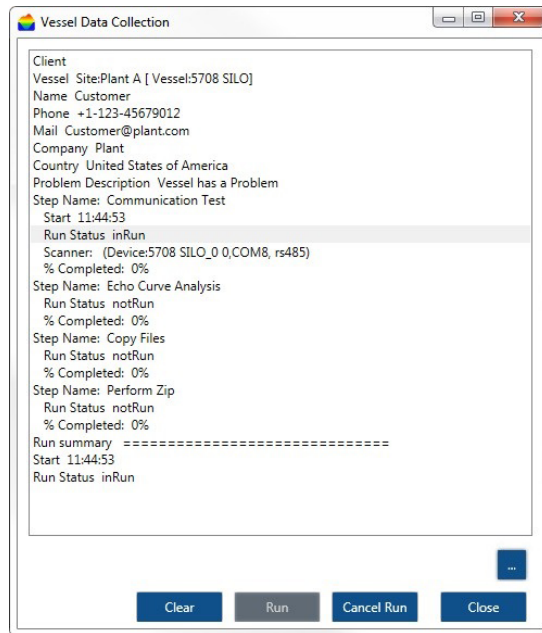

6. When the data collection process is completed, a run summary will appear at the bottom of the dialog box indicating *Start*, *End time* and *Status*.

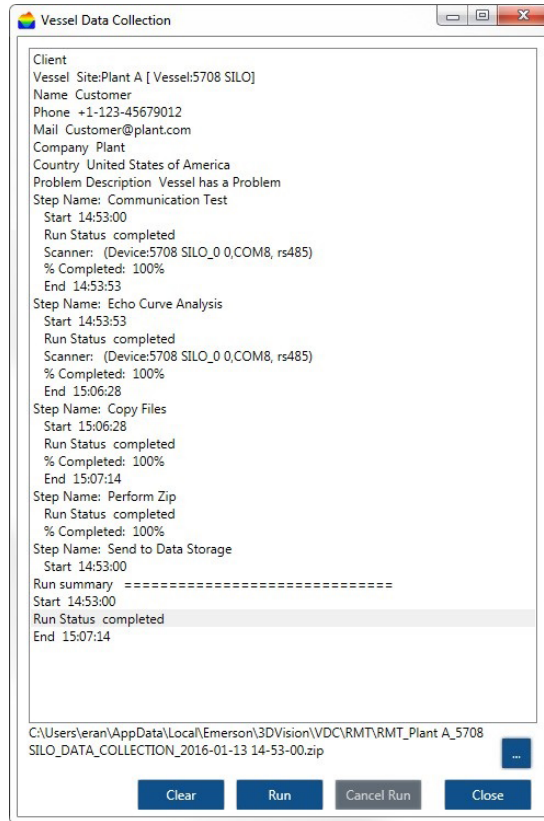

7. On the bottom part of the dialog box the path in which the zip file is saved will appear, allowing right-clicking on it to perform two operations: “Explore to VDC Directory” and “Copy File Name”.

The data collector collects the following information: Customer Data and problem description, Computer data, Rosemount 3DVision data and log files from the last seven days. It will also perform communication quality test and perform Echo Curve analysis on the vessel 10 times. All files will be zipped into a single file to simplify the transfer process.

It is possible at any time to stop the process and the files will not be sent.

On a typical vessel with one Rosemount 5708, the data collection operation should take about 15 minutes. Uploading to the storage depends on the Internet quality connection.

9.4 Removing the Rosemount 5708 head

1. Verify the power supply and data communication wires are disconnected.
2. Remove the rear panel.

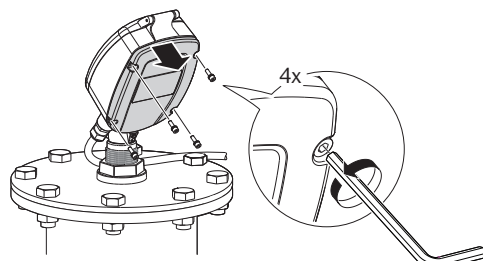

3. Gently remove the antenna cable connector.

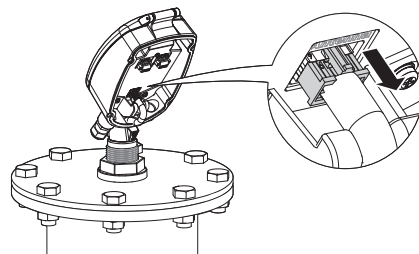

4. Remove the cable clamp.

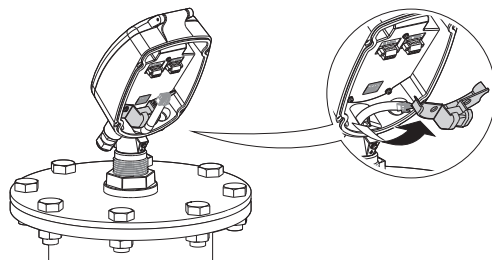

5. Loosen the front screw.

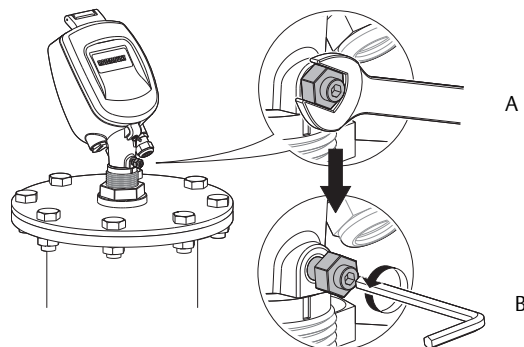

- A. Open wrench (13 mm)
B. Hex key (4 mm)

6. Make sure to pull the head all the way up until it leaves the top of the neck tube.

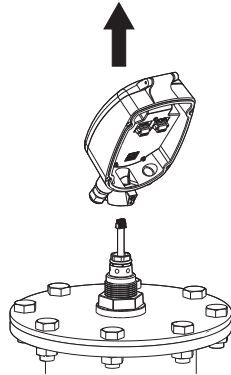

7. Remove the head from the neck tube.

9.5 Changing the Rosemount 5708 antenna

Replace the antenna only in the case of failure. Changing the antenna requires it to be taken out of the silo.

1. Verify the power supply and data communication wires are disconnected.
2. Remove the Rosemount 5708 head. For detailed instructions, see [“Removing the Rosemount 5708 head” on page 150](#).
3. Unscrew the bolts from the mounting plate.
4. Remove the Rosemount 5708 antenna with the mounting plate from the silo.

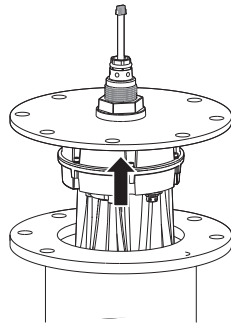

5. Remove the nut from the neck tube.

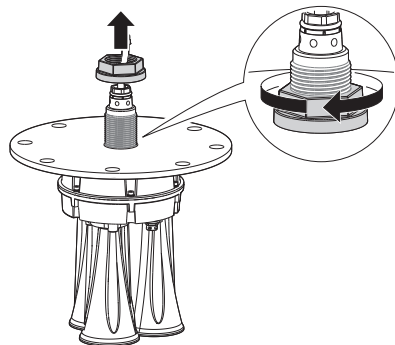

6. Disassemble the mounting plate from the old antenna.

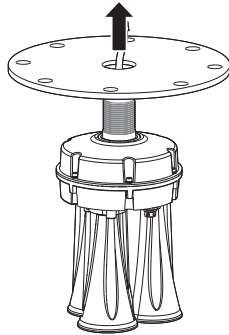

7. Install the mounting plate on the new antenna.

For reassembly procedures, refer to “Physical mounting” on page 17.

9.6 Diagnostic messages

The system does not give diagnostic messages. It gives indications, such as colored buttons. See [Parameters and alerts](#) below.

9.7 Parameters and alerts

The system allows for defining and displaying alerts of various types. Alerts are shown in a circular indicator located on the vessel icon in the vessel selection bar, the vessel rectangular boxes displayed when a site is selected, and in the vessel Overview tab. In addition, the vessel box in the overview tab provides a description of the alert.

9.7.1 Alert types

The system uses the round condition indicator to provide alerts for configuration and different notifications:

- System Notifications (in red): When the Rosemount 5708 is measuring temperatures below or above the specified temperature limits.
- Configuration Notifications (in yellow): When the Rosemount 5708 settings are not identical to the corresponding vessel settings (all configuration wizard settings except device position and horizontal angle).

The description of this alert is displayed above the vessel image in yellow font.

Vessel volume alert: Alert the operator that the material inside the silo exceeds the maximum value or is below the minimal value. Such indications will turn the entire vessel box red in site view, under the overview tab. This alert is activated when minimum and maximum volume thresholds are set.

Alerts appear in different colors for various failure conditions as follows:

- Grey: No connection
- Orange: Wrong configuration warning
- Red: Serious equipment malfunctioning, usually devices
- Green: indicates a proper condition

9.7.2 Selecting properties to be displayed

The alerts indicated per vessel can be selected. To select alerts for a vessel, right-click a vessel rectangular box (when a site is selected) and select **Properties**. The Parameters Definition window for the specific vessel opens (Figure 9-3).





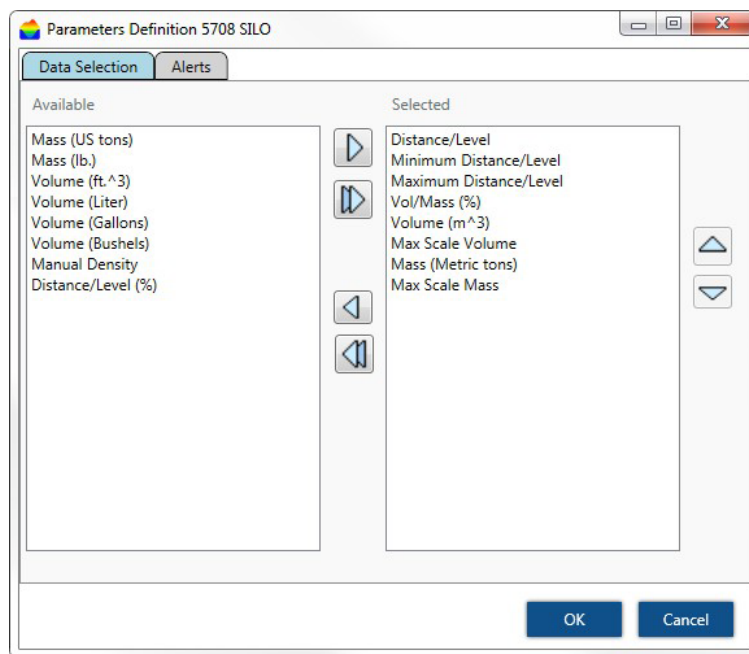

In the Data Selection tab choose the parameters to appear in the vessel box under the site selection. By default, the following parameters are selected and shown:

- Distance/Level (the distance or level parameter is shown as configured)
- Maximum and Minimum Distance/Level
- Volume (%)

Figure 9-3. Parameter Definition - Data Selection



Parameters can be removed and added, and the order they appear inside the vessel box can be changed.

- To remove a selected parameter, select the parameter for removal and select .
- To remove all selected parameters, select .
- To add a parameter, select the parameter from the Available pane and select .
- To add all available parameters, select .
- To move a selected parameter up, select the parameter from the Selected pane and select .
- To move a selected parameter down, select the parameter from the Selected pane and select .

9.7.3 Setting alert threshold

The alert threshold is specified in the **Alerts** tab of the Parameters Definition window (Figure 9-4). This triggers an alert when the material volume is above or below these values.

Figure 9-4. Alert Threshold

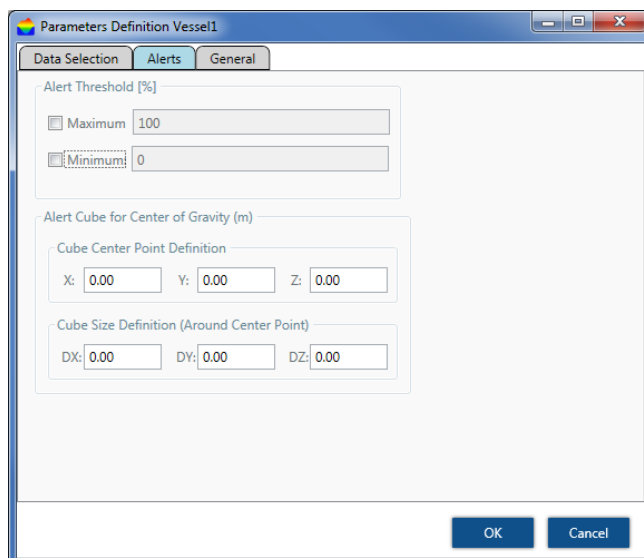

To define the alert thresholds:

1. Check the relevant option (or both). An unchecked option does not generate an alert for this vessel.
2. Set the value in volume percent where an alert should be generated above this value (maximum) or below this value (minimum).
3. Once set, an alert is generated when the material volume exceeds the maximum value set or drops below the minimum value set.

9.7.4 General tab

Set the number of sections on X axis and the number of sections on Y axis. The total number of sections is equal to $X * Y$ and limited to 99 sections. Set the number of sections to 1 in order to deactivate this feature.

Figure 9-5. Section settings

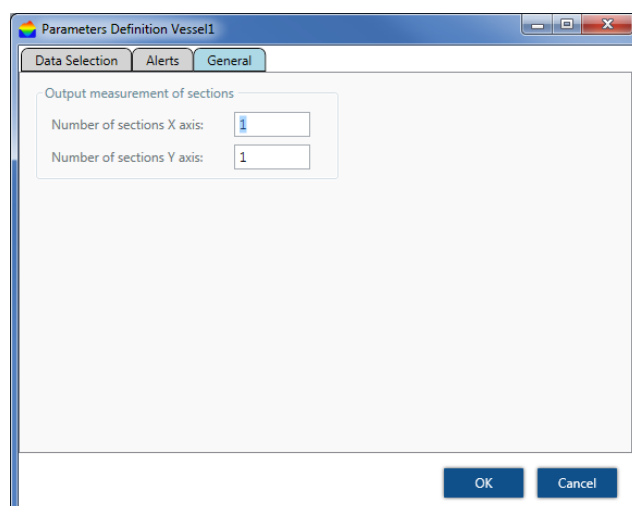

9.8 Service support

To expedite the return process outside of the United States, contact the nearest Emerson™ representative.

Within the United States, call the Emerson Instrument and Valves Response Center using the 1-800-654-RSMT (7768) toll-free number. This center, available 24 hours a day, will assist you with any needed information or materials.

The center will ask for product model and serial numbers, and will provide a Return Material Authorization (RMA) number. The center will also ask for the material to which the product was last exposed. Emerson Instrument and Valves Response Center representatives will explain the additional information and procedures necessary to return goods exposed to hazardous substances.

⚠ CAUTION

Individuals who handle products exposed to a hazardous substance can avoid injury if they are informed of and understand the hazard. If the product being returned was exposed to a hazardous substance as defined by Occupational Safety and Health Administration (OSHA), a copy of the required Safety Data Sheet (SDS) for each hazardous substance identified must be included with the returned goods.

For tracking and handling purposes, a separate RMA form must be completed and submitted for each product to be returned. The RMA request must include the product's serial number and a detailed description of the problem encountered.

Once an RMA number has been issued, a confirmation by e-mail or fax will be sent to the customer with the following information:

- RMA number
- Product and product quantities authorized for return
- Shipping address details
- RMA terms and conditions

For both in-warranty and out-of-warranty repairs, the customer is responsible for paying the outbound freight expense, and any applicable import and/or export duties and taxes. Emerson will pay the return freight expense for in-warranty repairs.

All products/parts returned for repair, both in-warranty and out-of-warranty, should have a label attached detailing the failure/fault/non-conformity and its RMA number.

Note

Emerson strongly advises its customers to hold a small quantity of products in stock for immediate replacement of faulty or damaged units at end-user sites, thereby providing the best service.

9.8.1 Packaging and shipping of return products/parts

It is preferable that original packaging, including any anti-static and foam wrapping, be used on all returned products. If the original product packaging is not available, adequate packing should be used taking into account the method of shipment of the returned product.

The customer is responsible for delivering the returned product to factory safely and undamaged. The RMA number should be clearly marked on all returned products, boxes, packages and accompanying paperwork. RMA requests received by the factory service department that are not clearly marked may experience delay in processing.

Discrepancies

Any product received without a proper RMA request will be returned to the customer at the customer's expense. If any product and/or component(s) of the product listed on the request are missing from the box, the customer will receive notification of the discrepancy and a replacement part will not include the missing component(s). Any unauthorized product included with the RMA shipment may be returned at Emerson's discretion.

Appendix A Specifications and Reference Data

Product Certifications	page 157
Ordering Information, Specifications, and Drawings	page 157

A.1 Product Certifications

To view current Rosemount 5708 Product Certifications, follow these steps:

1. Go to Emerson.com/Rosemount/Rosemount 5708.
2. Scroll as needed to the green menu bar and click **Documents & Drawings**.
3. Click **Manuals & Guides**.
4. Select the appropriate Quick Start Guide.

A.2 Ordering Information, Specifications, and Drawings

To view current Rosemount 5708 Ordering Information, Specifications, and Drawings, follow these steps:

1. Go to Emerson.com/Rosemount/Rosemount 5708.
2. Scroll as needed to the green menu bar and click **Documents & Drawings**.
3. For installation drawings, click **Drawings & Schematics** and select the appropriate document.
4. For ordering information, specifications, and dimensional drawings, click **Data Sheets & Bulletins** and select the appropriate Product Data Sheet.

Appendix B Connection via Modbus RTU

Initial settings	page 159
Registers	page 160
Communication examples	page 160

Note

These instructions apply to a direct connection between the DCS/SCADA system to the Rosemount™ 5708 3D Solids Scanner directly.

B.1 Initial settings

COM port settings:

- Baud rate = 115200
- Data bits = 8
- Parity = None
- Stop bits = 1

In order to get the values from the device, a Modbus® RTU command with function code 3 should be executed.

The address of the device equals its polling address + 1.

B.2 Registers

The relevant parameters are stored in registers 40001- 40026 (see [Table B-1](#)). All parameters are stored [Table B-1. Registers](#)

Number	Register number	Parameter	Units	Type
1	40001 and 40002	Avg. distance	m	Floating point
2	40003 and 40004	Min distance	m	Floating point
3	40005 and 40006	Max distance	m	Floating point
4	40007 and 40008	Volume	% (* 1000)	Floating point
5	40009 and 40010	4-20mA	mA	Floating point
6	40011 and 40012	SNR	dB	Floating point
7	40013 and 40014	Temperature	°C	Floating point
8	40015 and 40016	Temperature	°F	Floating point
9	40017 and 40018	Avg. level	m	Floating point
10	40019 and 40020	Bulk density	g/cm ³	Floating point
11	40021 and 40022	Mass	customer unit	Floating point
12	40023 and 40024	S/N	number	Long integer
13	40025 and 40026	Tag name	First 4 chars	4 characters integer

as IEEE754 floating points. Therefore, each parameter is stored in two consecutive registers. The byte sending order is from high to low.

B.3 Communication examples

Communication examples for a Rosemount 5708 with polling address 0:

Example A

- To retrieve the average distance, we send:
01 03 00 00 00 02 C4 0B
- A sample reply would be:
01 03 04 3D 85 1E 20 EE 0E

This means that Distance = 0x3D851E20, which represents a float value of “0.065”.

Example B

To acquire all relevant parameters, we send:
01 03 00 00 00 1A C4 01

Note

Mass value is in the chosen configured units and relevant only if the device linearization is configured to mass.

Appendix C Connection via RS-485

Physical layer	page 161
Parameters and units	page 161

C.1 Physical layer

The physical layer of RS-485 is as follows:

- Baud rate = 115200
- Data bits = 8
- Parity = None
- Stop bits = 1

C.2 Parameters and units

The available parameters and their units are as follows:

Parameter	Units
Avg. distance	m
Min distance	m
Max distance	m
Volume	%
4-20mA	mA
SNR	dB
Temperature	°C
Temperature	°F
Avg. level	m
Bulk density	g/cm ³
Mass	Customer units
S/N	number
Tag name	First 4 chars

To retrieve all 13 parameters, the Rosemount™ System Controller needs to transmit a single command. The packet format of the request is as follows:

1 BYTE	1 BYTE	4 BYTES	2 BYTES
Polling address + 1	03	00 00 00 1A	CRC-16

- The above values are all hexadecimal
- For CRC-16, see reference implementation in [Appendix A: Specifications and Reference Data](#)
- The below table indicates the request string for retrieving data from 15 devices (polling addresses 00 to 15):

Table C-1. Request String for Retrieving Data from Rosemount 5708

Polling address	Request
00	01 03 00 00 00 1A C4 01
01	02 03 00 00 00 1A C4 32
02	03 03 00 00 00 1A C5 E3
03	04 03 00 00 00 1A C4 54
04	05 03 00 00 00 1A C5 85
05	06 03 00 00 00 1A C5 B6
06	07 03 00 00 00 1A C4 67
07	08 03 00 00 00 1A C4 98
08	09 03 00 00 00 1A C5 49
09	0A 03 00 00 00 1A C5 7A
10	0B 03 00 00 00 1A C4 AB
11	0C 03 00 00 00 1A C5 1C
12	0D 03 00 00 00 1A C4 CD
13	0E 03 00 00 00 1A C4 FE
14	0F 03 00 00 00 1A C5 2F
15	10 03 00 00 00 1A C7 40

The packet format of the reply is as follows:

1 BYTE	1 BYTE	1 BYTE	4 BYTES	4 BYTES	4 BYTES
Polling address + 1	03	34	Avg. distance	Min. distance	Max. distance

4 BYTES	4 BYTES	4 BYTES	4 BYTES	4 BYTES	4 BYTES
Volume	4-20 mA	SNR	Temp (°C)	Temp (°F)	Avg. level

4BYTES	4 BYTES	4 BYTES	4 BYTES	2 BYTES
Bulk density	Mass	S/N	Tag name	CRC-16

Each of the 4-byte blocks represents a floating point value according to the IEEE-754 standard. For more information about the standard, refer to the following web page:
<http://standards.ieee.org/findstds/standard/754-1985.html>.

Example

Suppose the reply starts as follows (in this example, we show only the first 4 bytes of payload):

Byte number	Value
00	01
01	03
02	34
03	3D
04	85
05	1E
06	20
...	...

Then the average distance is represented by a 4-byte-block of 0x3D851E20 which corresponds to the floating point value of 0.065m.

1. To verify the value, enter “3d851e20” in the *hexadecimal representation* text box at the <http://babbage.cs.qc.cuny.edu/IEEE-754/index.xhtml> web page.
2. To calculate CRC-16, use the <http://www.lammertbies.nl/comm/info/crc-calculation.html> web site.
3. Select input type **HEX**.
4. Type in the string to convert and select the **Calculate CRC** button.
5. Look for the **CRC-16 (Modbus)** value in the table.

The output result is flipped. For example, if the result is 0x01C4, the two bytes to be transmitted are C401.

Appendix D Rosemount LinkPro Operating Instructions

About this document	page 165
Rosemount LinkPro overview	page 166
Technical specifications	page 168
Mounting	page 170
Rosemount LinkPro Setup	page 172
Modem wizard	page 175
Troubleshooting	page 178

D.1 **About this document**

This appendix provides information required for mounting, connecting, and setting-up the Rosemount LinkPro. Read this information before operating and keep this manual accessible near the device.

D.1.1 **Intended audience**

This appendix is intended for trained personnel working with Rosemount LinkPro in conjunction with other Emerson™ products, such as the Rosemount™ 5708. It contains essential information and should be read prior to installation and operation.

D.1.2 **Safety**

This section provides safety instructions when using Rosemount LinkPro.

Authorized personnel

All operations described in this manual must be carried out by trained personnel authorized by the operator. The required personal protection equipment must be worn while working with the device.

Appropriate use

Operational reliability is ensured if the instrument is used in accordance with the specifications manual and possible supplementary instructions.

Due to safety and warranty reasons, any invasive work on the device not included in this manual may only be carried out by personnel authorized by the manufacturer. Unauthorized conversions or modifications are explicitly forbidden.

The internal GSM modem antenna should not be mounted outside the Rosemount LinkPro box.

Warning about misuse

Inappropriate or incorrect use of the instrument may cause application-specific hazards, e.g. vessel overflow or damage to system components through incorrect mounting or adjustment.

General safety instructions

Adhere to standard regulations and guidelines while using the Rosemount LinkPro. This includes all safety instructions in this manual, country-specific installation standards, and all prevailing safety regulations and accident prevention rules.

The operator is responsible for trouble-free operation of the instrument.

Note

This equipment has been tested and found to comply with the limits for a Class A digital device, pursuant to Part 15 of the FCC rules. These limits are designed to provide reasonable protection against harmful interference when the equipment is operated in a commercial environment. This equipment generates, uses, and can radiate radio frequency energy, and therefore, if not installed and used in accordance with this manual, may cause harmful interference to radio communications. Operation of this equipment in a residential area is likely to cause harmful interference in which case the user is required to correct the interference at his expense.

⚠ WARNING

- Changes or modifications to this equipment not expressly approved by the party responsible for compliance could void the user's authority to operate the equipment.
- This product was tested with special accessories (shielded and twisted cables), which must be used with the unit to assure compliance.

D.2 Rosemount LinkPro overview

The Rosemount LinkPro is used for easy bi-directional transfer of data between the Rosemount 5708 and the Rosemount 3DVision on a remote computer/system.

Such data can be measurement results, configuration, analysis, or software upgrade.

D.2.1 Components

The Rosemount LinkPro is composed of the following parts:

- Enfora GSM1318
- Modem
- ADAM 4520I RS-485 to RS-232 Converter
- Quad Band Antenna
- Terminal block
- 120Ω termination resistor
- Two M20 cable glands

Figure D-1. Rosemount LinkPro Configuration

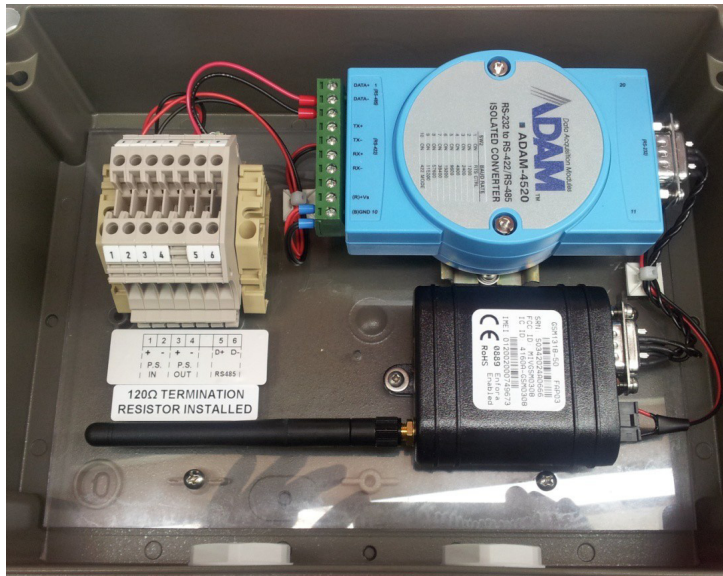

D.2.2 Area of application

The Rosemount LinkPro is connected via an easy and reliable standard GSM (Global System for Mobile Communications network) connection (using standard GSM frequencies). Regular SIM (Subscriber Identity Module) cards supporting GPRS (General Packet Radio System) are used for the connection.

D.2.3 Technical concept

The purpose of Rosemount LinkPro is to enable communication with Emerson products via a GSM network. It enables Emerson to provide excellent service to its customers, upgrade units at the click of a button, and is a great advantage in situations where traditional wiring would require more work and a higher cost.

Rosemount LinkPro is easy to install and offers great flexibility in adjustment, configuration, and remote diagnosis. By connecting Rosemount LinkPro to a Rosemount 5708, the user can remotely receive data, control the data, change the unit's parameters, and upgrade the Rosemount 5708 from firmware, at the click of a button.

D.2.4 Operation

The Rosemount 5708 parameters can be adjusted using a Windows-based PC application (with the appropriate version of the Rosemount 3DVision software installed).

For additional wiring instructions and how to connect the Rosemount 3DVision to the Rosemount 5708 using Rosemount LinkPro, refer to the Rosemount 5708 installation and Rosemount 3DVision operation instruction manuals.

D.2.5 GPRS modem

The GPRS modem is a compact, stand-alone, cellular modem. It is designed for communication with devices installed in remote locations using existing cellular networks.

Components

The following figures show the outer case of the modem.

Figure D-2. Modem



The outer case of the modem includes the following:

1. Green LED indicator – Indicates GSM network registration status.
2. External SIM slot – Compartment for the SIM card with an option to lock the SIM.
3. Antenna connector – Connector for the antenna.
4. Power supply connector – Port to connect the modem to the power supply.
5. RS-232 connector – Port to connect between the modem and the converter.

D.3 Technical specifications

This chapter provides technical specifications of the modem and Rosemount LinkPro.

D.3.1 Modem specifications

This section lists the technical specifications of the modem.

Table D-1. Modem Technical Specifications

General			
Antenna	SMA connector		
Radio performance			
Frequency (MHz)	Quad Band (850/900/1800/1900)		
Sensitivity	-106 dBm typical)		
Transmit power	Class 4 (2W@850/900 MHz; Class 1 (1W@1800/1900 MHz)		
Operating power			
Band	Mode	Average (mA)	Peak (A)
GSM 850/900	1 TX/1 RX	200	1.30
GSM 1800/1900	1 TX/1 RX	160	0.92

⚠ WARNING

Use of the modem out of the specified voltage range may result in damage to the device and/or undesirable results.

D.3.2 Rosemount LinkPro specifications

This section provides the technical specifications of the Rosemount LinkPro.

Table D-2. Rosemount LinkPro Technical Specifications

Characteristics	
Materials	Polystyrene
Weight	3.13 lb (1.42 kg)
Dimensions (L × W × H)	10 x 7 × 3.5-in. (255 × 180 × 90 mm) - not including cable glands
Voltage supply	
Operating voltage	10 Vdc to 30 Vdc (nominal 24 Vdc)
Average power consumption (idle mode)	1.5 W
Peak power consumption (transmit mode)	18 W
Power source limitation	2A
Ambient conditions	
Temperature	-22 to +158 °F (-30 to +70 °C)
Protection	IP66
CE Conformity	
EMC	Emission EN 301 489-7 V1.3.1:2005 standard harmonized under R&TTE Directive 1995/5/EC and EMC Directive 2004/108/EC Article 6(2)
Safety	EN 60950-1:06; EN 60950-22:06

Table D-2. Rosemount LinkPro Technical Specifications

Radio	
Spurious emissions	EN 301 511 V9.0.2
FCC approval	FCC 47 CFR part15:2007, subpart B, class A
Electromechanical data	
Cable entry/plug	2 × cable gland M20 x 1.5 (cable ø 8mm to 13mm)

Figure D-3. Product Dimensions

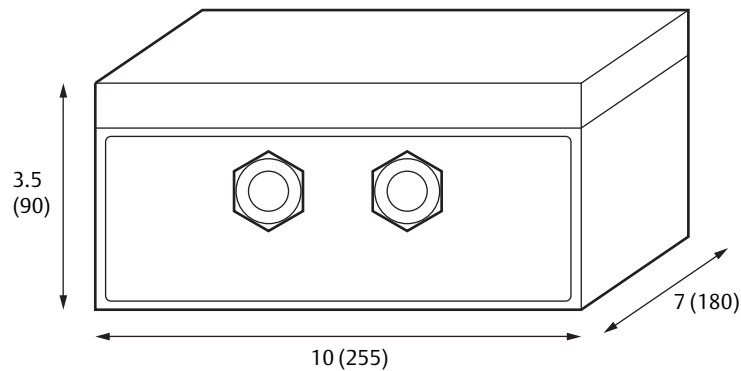

Dimensions are in inches (mm).

D.4 Mounting

This chapter provides information on mounting the Rosemount LinkPro.

D.4.1 Position

Select an easy-to-reach position for mounting and connecting. Wiring instructions are located on a label inside the unit's front cover.

Mount the instrument to ensure optimum GSM reception. Do not mount in a closed metallic box/rack/container. Since the antenna was designed to be internal, the Rosemount LinkPro housing is made of plastic to enable maximal reception.

D.4.2 Moisture

Use the recommended cables (see [Selecting connection cable page 173](#)) and tighten the cable gland to protect the instrument from moisture and penetration of water.

Lead the connection cable downward in front of the cable entry for additional protection. Rain and condensation water can thus drain off naturally without affecting the connection.

D.4.3 Wall mounting

To mount the Rosemount LinkPro on the wall:

1. Mark the holes in accordance with the following drilling template.

Figure D-4. Drilling Template

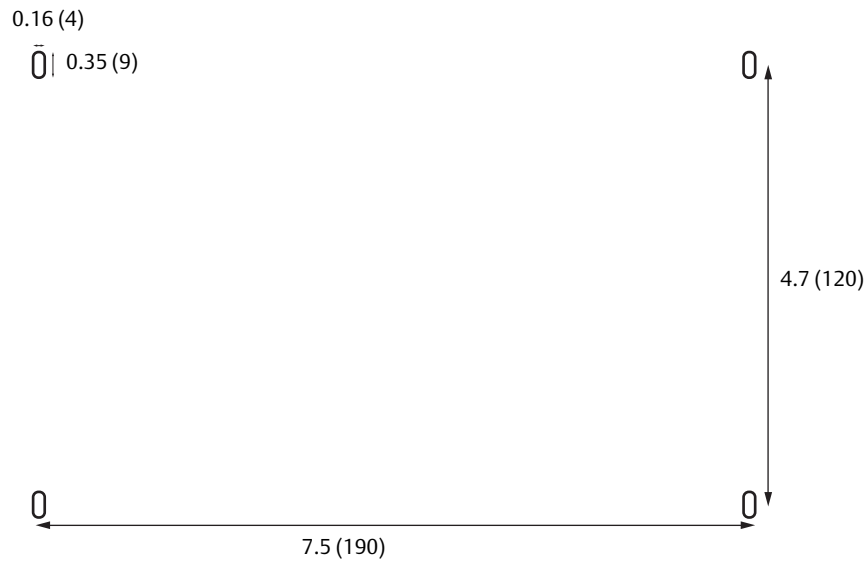

Dimensions are in inches (mm).

- Rosemount LinkPro dimensions: 10 x 7 x 3.5-in. (255 x 180 x 90 mm)
- Hole dimension: 0.16-in. (4 mm)

Note

The Rosemount LinkPro is not sized 100 percent in the drilling template (Figure D-4).

2. Using a flat screwdriver, open the front cover.
3. Unscrew the six screws holding the plate.
4. Remove the internal plate holding the components.
5. Break the four wall mounting knock-outs (Figure D-5).

Figure D-5. Wall Mounting Knock-outs

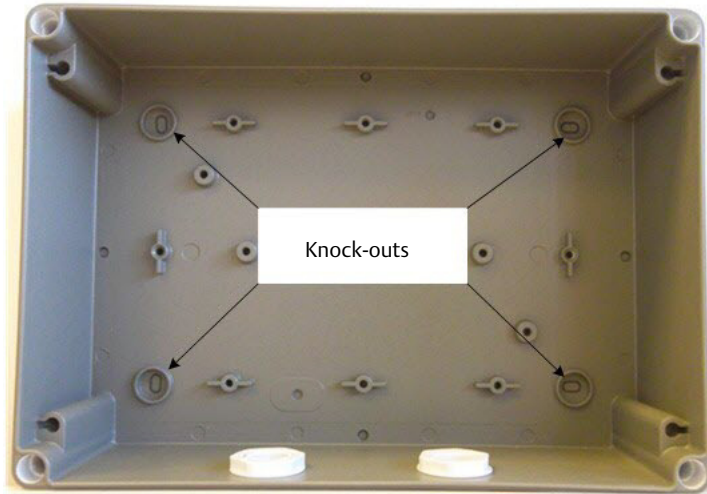

6. Using four screws, fasten the Rosemount LinkPro to the wall in the marked locations on the wall.

Note

Mount the Rosemount LinkPro with the cable glands facing downwards.

D.5 Rosemount LinkPro Setup

After mounting the Rosemount LinkPro, place the components inside as shown in [Figure D-1](#). Perform the procedures in this chapter to successfully connect the various connections.

D.5.1 Connection

Note the following safety instructions:

- Connect only in the complete absence of line voltage.
- If power surges are expected, surge protectors should be installed.
- **Ex applications:** In hazardous areas, observe relevant regulations. Acquire the necessary approvals and permits for the sensors and power supply units.
- The Rosemount LinkPro is not an intrinsically safe approved product.

Selecting connection cable

The Rosemount LinkPro is connected to a power supply with a standard cable that meets local regulatory standards. RS-485 rated cable with screening should be used to connect the sensors. Screening is necessary to ensure interference-free operation with other devices. The communication cable should be twisted pair and shielded, rated for a RS-485 communication standard, and have 120 Ohm impedance.

Cable screening and grounding

The communication cable shield must be grounded. Connect the shield in the Rosemount 5708 grounding point on one end and to a dedicated grounding on the other end. This can be, for example, the '-' port of the power supply.

D.5.2 Wiring plan

This section provides details of how to connect the wires.

Power supply

Detailed information on the power supply can be found in the [“Technical specifications” on page 168](#).

To connect to a power supply:

1. Loosen the four Rosemount LinkPro housing screws using a flat screwdriver.
2. Remove the housing cover.
3. Insert the Rosemount 5708 cable through the left gland of the Rosemount LinkPro.
4. Loosen the terminals with a small, flat screwdriver.
5. Connect the power supply wires to sockets “1” and “2” in accordance with [Figure D-6](#). Note the polarity.
6. Tighten the screws of the terminal.
7. Tighten the compression nut of the cable entry. The seal ring must wrap the cable completely.
8. Connect sockets “3” and “4” with a separate cable to the Rosemount LinkPro.
9. Screw on the Rosemount LinkPro housing cover.
10. If the cable is screened, refer to [“Cable screening and grounding” on page 173](#).

Figure D-6. Wiring Diagram

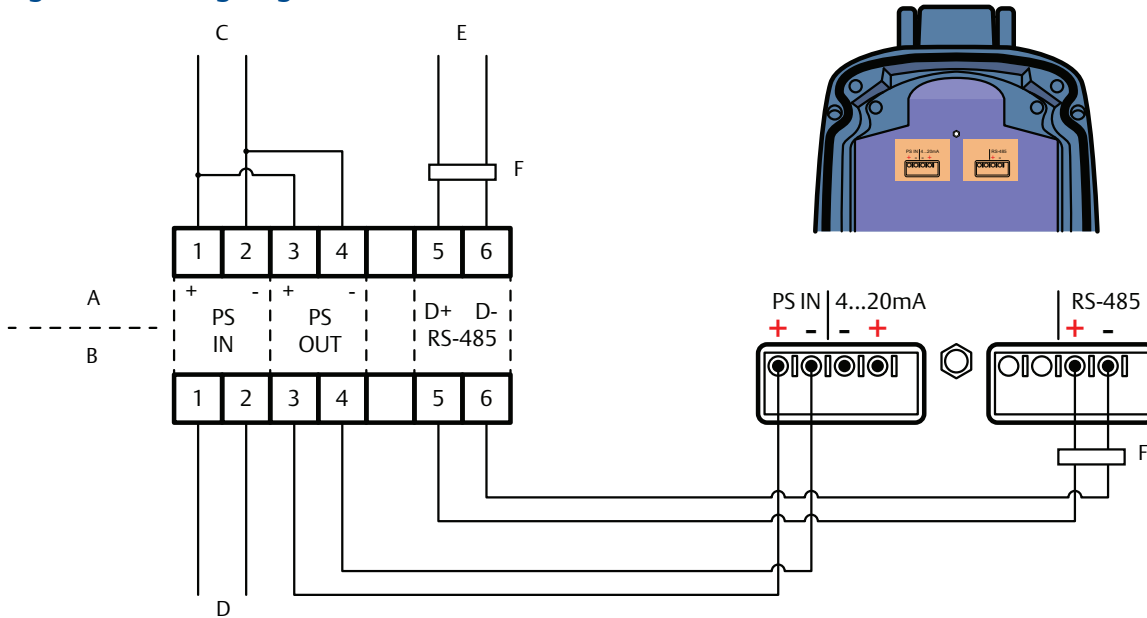

- A. Inside Rosemount LinkPro
- B. Outside Rosemount LinkPro
- C. To ADAM vonverter and GSM Modem
- D. From power supply
- E. To ADAM converter
- F. 120 Ω resistor

Connecting RS-485 Wires

To connect RS-485 wires to the Rosemount LinkPro:

1. Connect two wires to sockets “5” and “6” in accordance with [Figure D-6](#).
2. The Rosemount LinkPro is supplied with a 120 Ω resistor between sockets “5” and “6” (as shown in [Figure D-6](#)), Do not add another resistor.
3. Ensure there is another resistor on the far end of the RS-485 daisy chain bus.

D.5.3 Modem connection

Perform the following procedures to connect the modem to the system/computer. To install the SIM card into the modem:

1. Insert the SIM card into the external SIM slot.
2. Slide the SIM lock switch to the left to lock and secure the SIM card.

Note

Do not create loops, sharp bends, or crimps in the cables.

The green LED indicator flashes in attempt to register to the GSM network. When the modem is registered to a network, the green LED indicator is solid.

D.6 Modem wizard

The Modem Wizard is a software tool with a basic user interface that tests the modem for proper functionality and allows configuration of an Access Point Name (APN) details and mode operation. The Modem Wizard application supports both older Rosemount LinkPro models that include an EZ-864 modem and the new Enfora GSM1318 modem.

Connect the Rosemount LinkPro to the computer (using RS-485 to USB/RS-232 converter) and power supply. Ensure no Rosemount 5708 is connected to the Rosemount LinkPro.

D.6.1 Getting started

The Modem Wizard application requires no installation and can be found in the distributor's zone of the Emerson website.

Perform the following procedures to run the Modem Wizard.

To open the Modem Wizard:

Double-click on the Modem Wizard executable file. The Modem Wizard opens.

Figure D-7. Modem Wizard User Interface

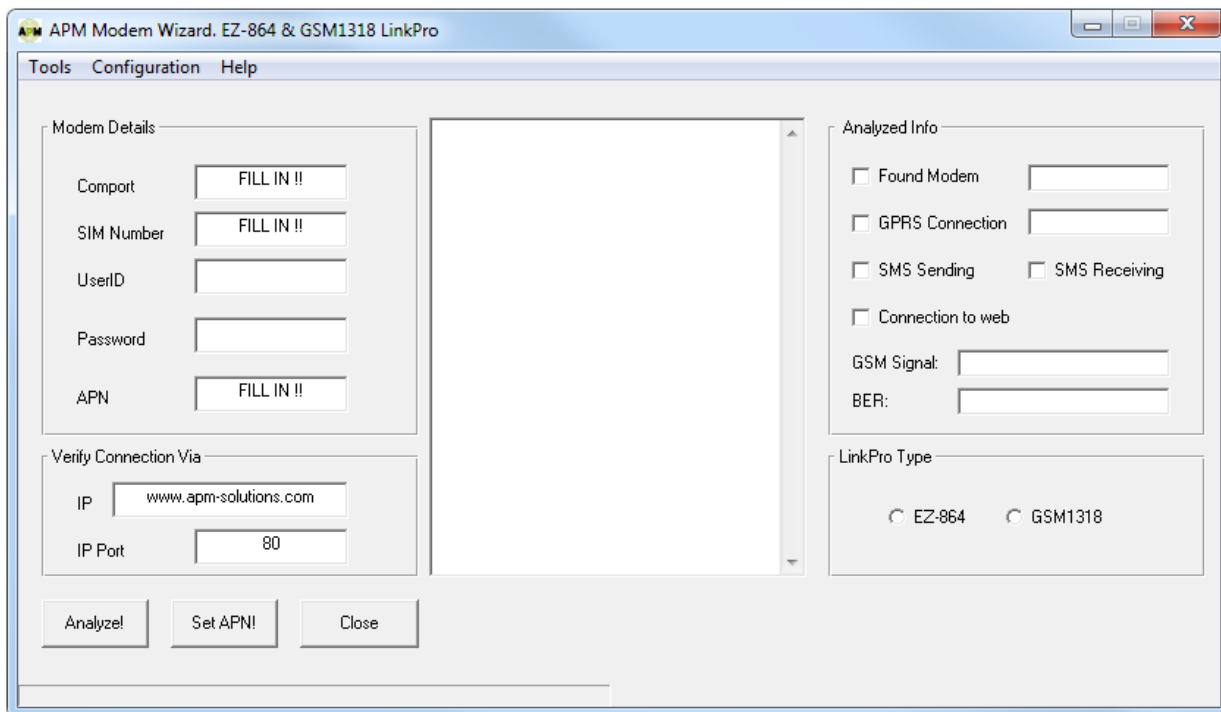

D.6.2 Test performance

To test proper performance of the modem:

1. In the *Modem Details* area, enter the COM port number in the *Comport* field (this field is mandatory).
2. In the *SIM Number* field (this field is mandatory), enter the SIM card phone number.
3. In the *APN* field, enter the APN. If it is unknown, contact the network provider.
4. Enter the *UserID* and *Password* in their correct fields if the GPRS network is protected.
5. Select **Analyze**. The wizard analyzes the modem performance. A completion dialog box appears.
6. Select **OK**. The log of commands is displayed in the middle pane and the results are displayed in the right pane (see Figure D-8).

Figure D-8. Test Results

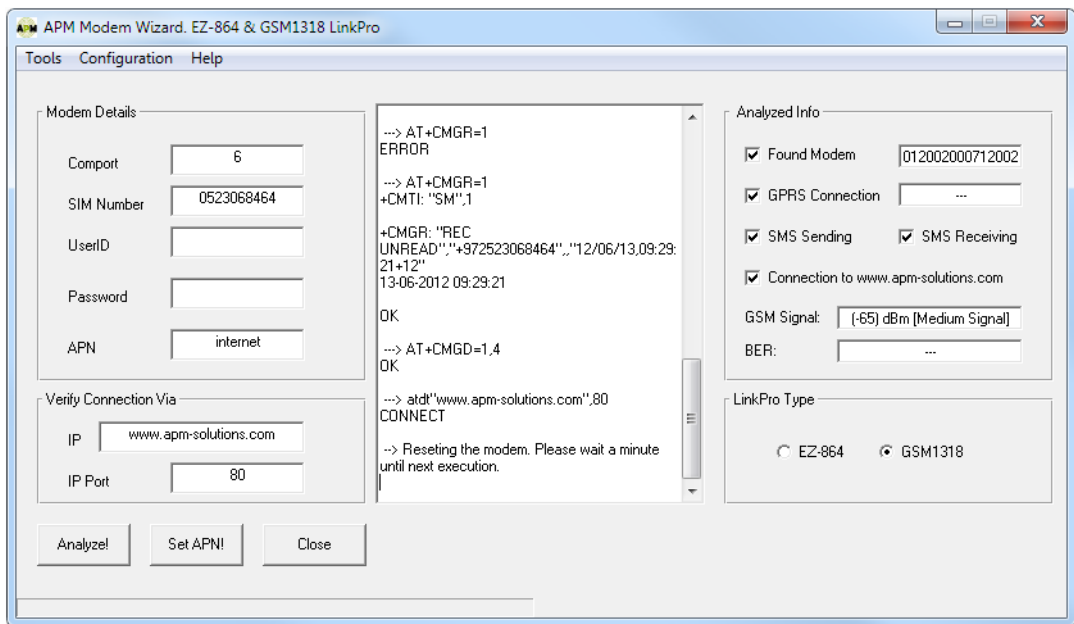
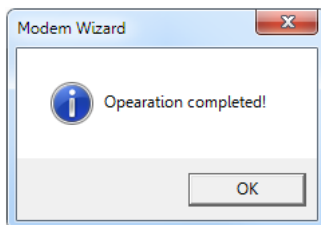

Figure D-9. Test Completion



D.6.3 Configure APN details

To configure the modem parameters:

1. In the *Modem Details* area, enter the COM port number in the *Comport* field (this field is mandatory).
2. In the *APN* field (this field is mandatory), enter the APN.
3. Enter the *UserID* and *Password* if required by the cellular network provider.
4. Select **Set APN!** to store the user ID and password in the modem. A confirmation window appears.

Figure D-10. Confirm APN Details

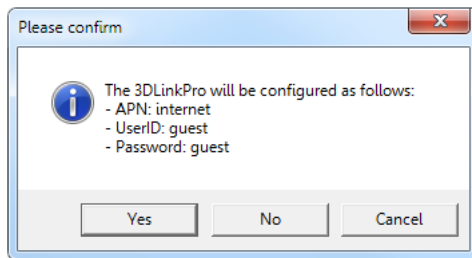

5. Select **Yes** to set the details in the modem. The Test Completion window appears (Figure D-9).

D.6.4 Configure mode of operation

To configure the operation mode:

1. In the *Configuration* menu, select the relevant mode in accordance with the following tables. A confirmation window appears (Figure D-11).

Table D-3. EZ-864 modes

Mode	Modem band	Region
Mode 0	GSM 900MHZ + DCS 1800MHZ	Europe/Israel
Mode 1	GSM 850MHZ + PCS 1900MHZ	USA - AT&T and MNV0
Mode 2	GSM 850MHZ + PCS 1900MHZ	USA - T mobile & MNV0
Mode 3	GSM 900MHZ + PCS 1900MHZ	Mexico

Table D-4. GSM1318 modes

Mode	Modem band	Region
Mode 0	Automatic	Global
Mode 1	GSM 900MHZ + DCS 1800MHZ	Europe/Israel
Mode 2	GSM 850MHZ + PCS 1900MHZ	USA
Mode 3	GSM 900MHZ + PCS 1900MHZ	Mexico

Note

Mode 0 (automatic band detection) is recommended for GSM1318.

Figure D-11. Mode Configuration Window

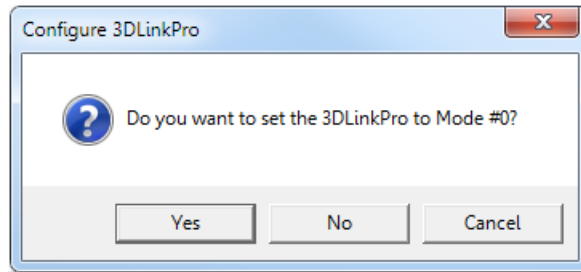

2. Select **Yes**. The wizard configures the modem parameters. A completion dialog box appears ([Figure D-9](#)).

D.7 Troubleshooting

When facing a communication problem with the Rosemount LinkPro, check the following:

1. Verify with the cellular provider that the SIM card supports GPRS data.
2. Verify with the cellular provider the APN, user name, and password (if required) needed to access the GPRS data.
3. Ensure that the Rosemount LinkPro is configured with the User Name and Password for GPRS Internet Access if required (use the Modem Wizard to configure the Rosemount LinkPro).
4. Connect the Rosemount LinkPro directly to the computer and run the Modem Wizard, fill all required fields and select **Analyze**. Ensure that the analysis passes all tests. If not, consult with the cellular provider or Emerson Technical Support. Ensure that the Rosemount 5708 is not connected to the Rosemount LinkPro while analyzing.
5. Check the power supply connected to the Rosemount LinkPro, it should be 24Vdc with a limitation above 1.5A.
6. Ensure that every Rosemount 5708 has a different polling address and one device use to polling address 00.
7. Check the RS-485 connection between the Rosemount 5708 and the Rosemount LinkPro.
8. Check for mutual grounding of the RS-485 between the power supply, Rosemount LinkPro, and Rosemount 5708.
9. Check the existence of 120 Ω resistors on both ends of the RS-485 bus.
10. Ensure that cable resistance is 60 Ω +/-5% between the D+ and D- ports. Ensure that there is no connection to the Rosemount 5708 and the communication is idle.
11. Check the LED's behavior on the modem. The green LED should be solid when the SIM card is registered with the network.
12. Try calling the Rosemount LinkPro with the SIM card to check that the Rosemount LinkPro has acquired the network.
13. Verify that the SIM card phone number is correct.
14. Verify that the SIM card receives SMS messages. This can be tested by inserting the SIM card into a mobile phone and checking the options of receiving and sending SMS messages.
15. Send the following reset SMS to the Rosemount LinkPro: HW MODEM RESET (this is a case sensitive message).
16. Ensure that the TCP port is open in the router and forwarded to your computer.
17. Verify that your computer still has the same External IP address.
18. Re-check the External IP address of the network your computer is connected to (in websites like: www.whatismyip.com).

Appendix E Accessories

Neck extension	page 184
Angle adapter	page 186

E.0.1 Cable extender

1. Kit contains:

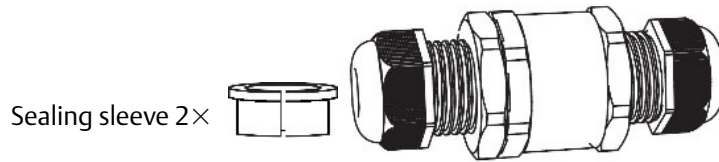

2. Pass cables from antennas and extension cable through the cable glands.

Connect connectors.

Insert sealing sleeves on both sides to seal the cable extender.

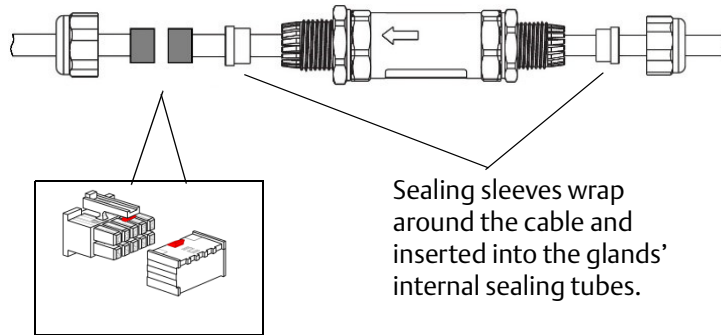

3. Tighten cable glands body to the tube at 2.5Nm (22lbs-In).

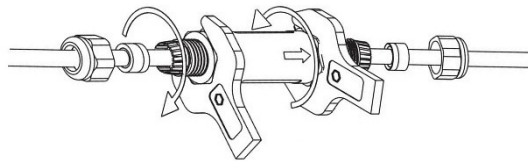

4. Tighten cable glands body to the Nut at 2.5 N-m (22 lbs-in).

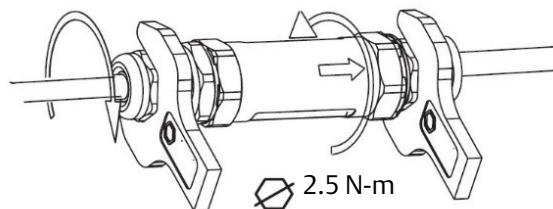

E.0.2 Neck Extension



1. Mount the neck extension only after connecting the cable extender.



O-rings remain in place.

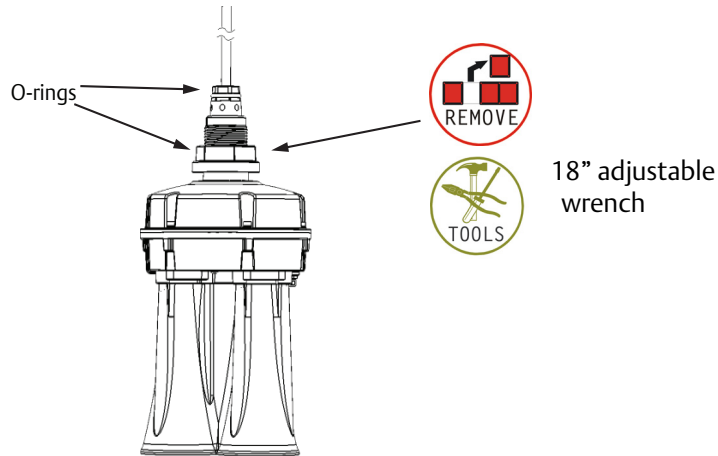

2. Cable through neck extension.

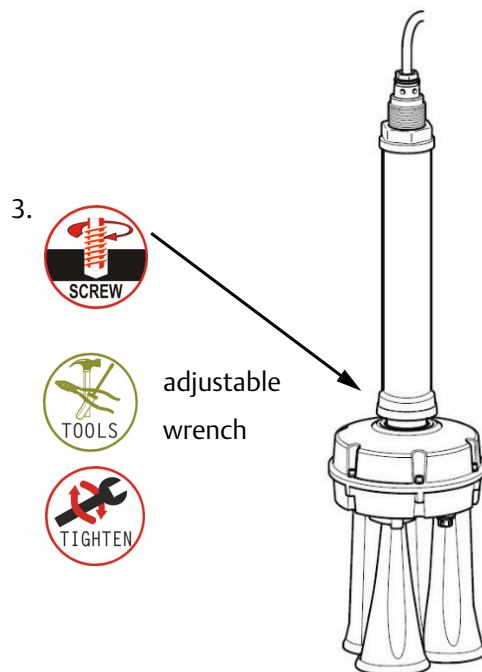

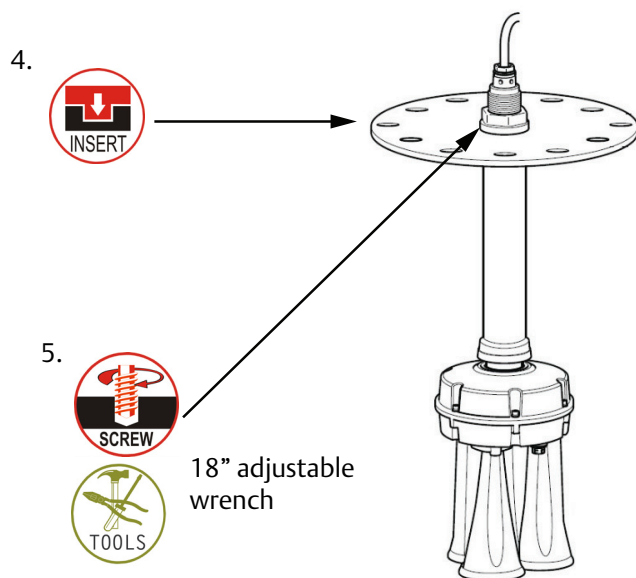

E.0.3 Package components

The cable extender kit includes:

- Cable at the ordered length
- Cable case
- Two plates
- Cable extender
- Neck extension

E.1 Neck extension

E.1.1 Required equipment

- O-rings
- 18-in. adjustable wrench

E.1.2 Assembling the neck extension

1. Mount the neck extension only after connecting the cable extender.
2. Remove nut from neck tube using an 18-in. adjustable wrench.

Note

Ensure that O-rings remain in place.

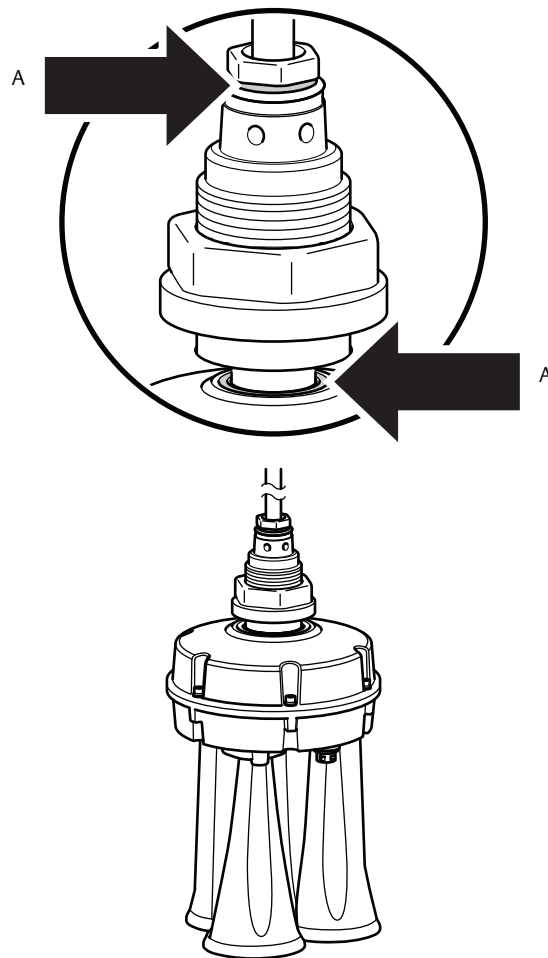

A. O-ring

3. Insert cable through neck extension.
4. Tighten neck extension using the 18-in. adjustable wrench.

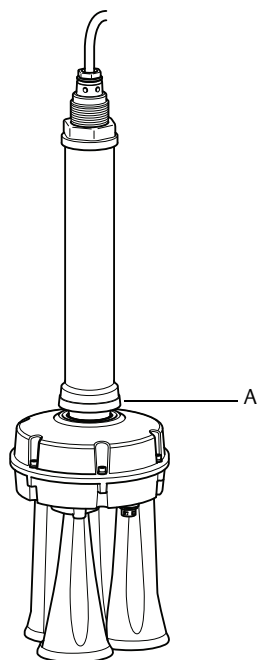

A. Screw

5. Insert mounting plate.

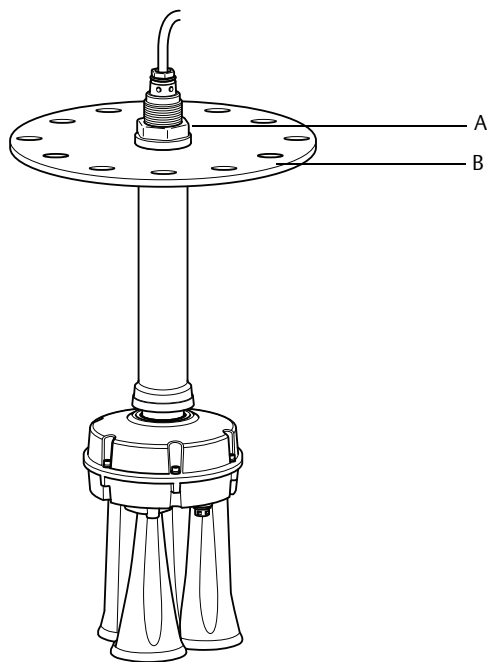

A. Screw
B. Mounting plate

6. Tighten screw using the 18-in. adjustable wrench.

E.2 Angle adapter

E.2.1 Parts of the adapter

- Angle adapter nut

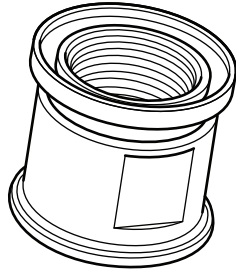

- Angle adapter

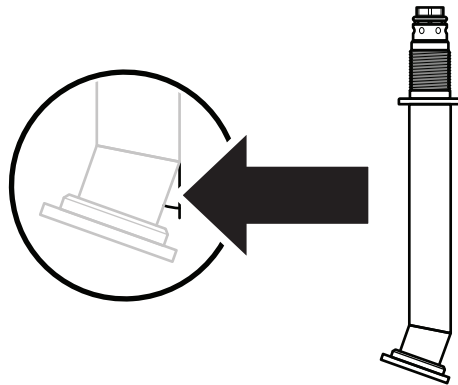

Note

The angle adapter is available in 10° and 20° versions.

- Installation kit

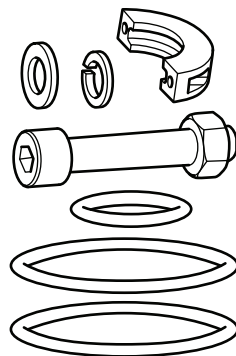

Kit components:

- 2 × Clamps
- 2 × M8 screws
- 2 × Nuts
- 2 × Washers
- 2 × Large O-rings
- 1 × Small O-ring

Note

It is recommended to use a Rosemount-supplied 19.7-in. (50 cm) cable extender or the high temperature version of Rosemount 5708 with a 19.7-in. (50 cm) extended cable.

E.2.2 Assembling the angle adapter

1. Remove nut from horn assembly.

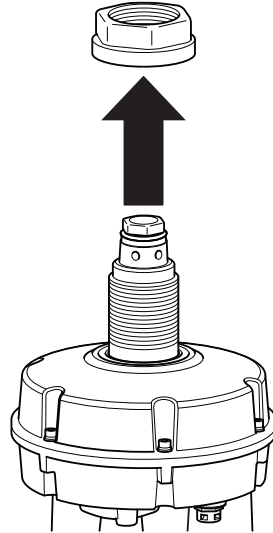

2. Screw the angle adapter nut all the way down.
3. Put the large O-ring in place.

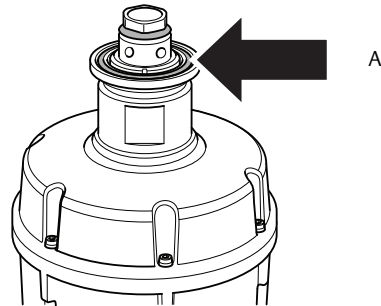

A. O-ring

4. Ensure the notch at the top of the angle adapter is facing the same direction as the horns. The notch is designed to align the horns with the angle adapter.

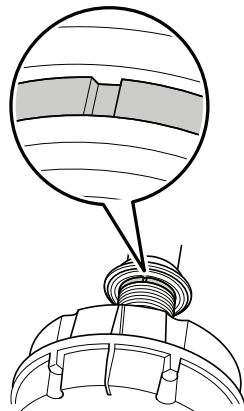

- Screw the angle adapter nut up to the angle adapter.

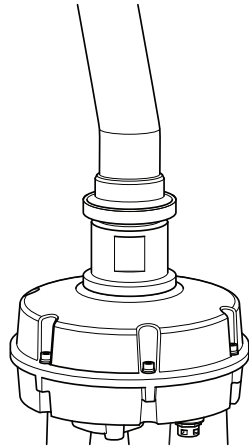

- Place the clamps over the angle adapter and the nut to lock them together with the screws and nuts.

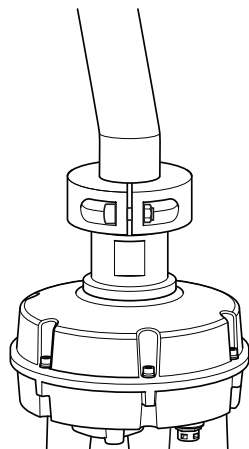

- Fit the two O-rings on top of the angle adapter.

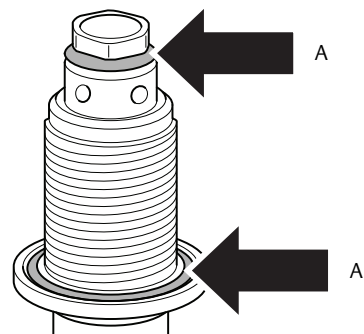

A. O-ring

8. Fit mounting plate over the angle adapter.

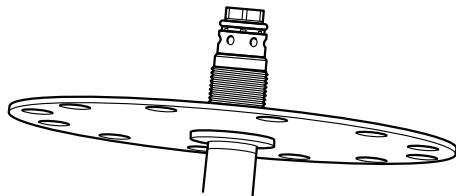

9. Secure the mounting plate with the nut.

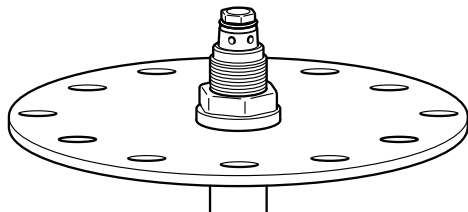

10. Insert the assembled Rosemount 5708 (with the mounting plate mounted) into the vessel and direct the device to the center of the vessel.

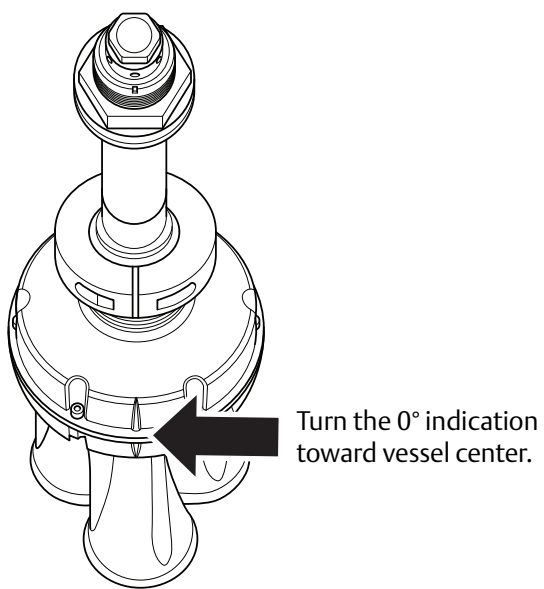

11. Mount the Rosemount 5708 head over the angle adapter. See “Step 4: Install head” on page 20 more information.

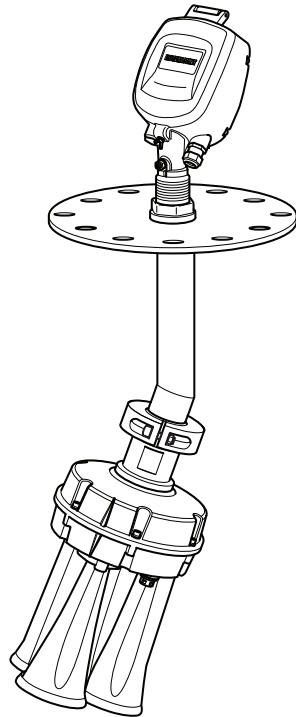

12. After successful installation of the angle adapter, connect the Rosemount 5708 to the Rosemount 3DVision and configure the angle adapter field according to the actual installation.

Select **Device > Advanced Parameters...**

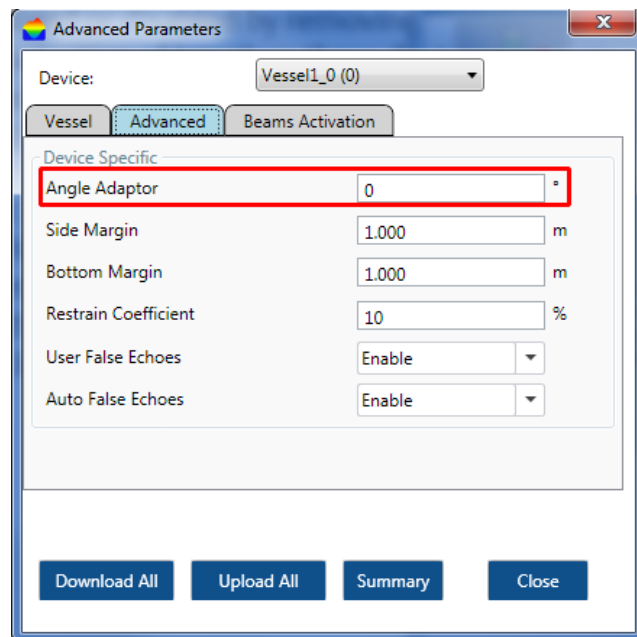

The angle can be between 0° and 30°. For more information on how to set the angle adapter field, see “Advanced parameters” on page 96.

Index

Numerics

4-20 mA connection 30

A

Advanced commissioning 134

Advantages 131

C

Cable selection 23

Connection methods 30

Connection procedure 24

D

Device installation 134

F

Fitting 11

G

Grounding 23

H

HART communication 31

Hazardous areas 23

I

Inflowing material 10

Introduction 1

L

Local user interface 33

Location 8

M

Measuring range 5

Models 133

Mounting direction 9

Multiple Rosemount 5708 connection 32

O

OSHA 147

P

Power supply 24

R

Rosemount 3DVision Clients 136

Rosemount 3DVision Computers 42

Rosemount 3DVision Server Connection 44

Rosemount 5708 orientation 9

Rosemount LinkPro 32

RS-485 communication 31

S

Server-client architecture 42

Service Support 1

Service support 147

Standpipe mounting 10

Support 147

System architecture 45

System overview 129

System requirements 132

T

TCP/IP communication 32

W

Wiring 24

Global Headquarters

Emerson Automation Solutions

6021 Innovation Blvd.
Shakopee, MN 55379, USA
+1 800 999 9307 or +1 952 906 8888
+1 952 949 7001
RFQ.RMD-RCC@Emerson.com

North America Regional Office

Emerson Automation Solutions

8200 Market Blvd.
Chanhassen, MN 55317, USA
+1 800 999 9307 or +1 952 906 8888
+1 952 949 7001
RMT-NA.RCCRFQ@Emerson.com

Latin America Regional Office

Emerson Automation Solutions

1300 Concord Terrace, Suite 400
Sunrise, FL 33323, USA
+1 954 846 5030
+1 954 846 5121
RFQ.RMD-RCC@Emerson.com

Europe Regional Office

Emerson Automation Solutions Europe GmbH

Neuhofstrasse 19a P.O. Box 1046
CH 6340 Baar
Switzerland
+41 (0) 41 768 6111
+41 (0) 41 768 6300
RFQ.RMD-RCC@Emerson.com

Asia Pacific Regional Office

Emerson Automation Solutions

1 Pandan Crescent
Singapore 128461
+65 6777 8211
+65 6777 0947
Enquiries@AP.Emerson.com

Middle East and Africa Regional Office

Emerson Automation Solutions

Emerson FZE P.O. Box 17033
Jebel Ali Free Zone - South 2
Dubai, United Arab Emirates
+971 4 8118100
+971 4 8865465
RFQ.RMTMEA@Emerson.com



[Linkedin.com/company/Emerson-Automation-Solutions](https://www.linkedin.com/company/Emerson-Automation-Solutions)



[Twitter.com/Rosemount_News](https://twitter.com/Rosemount_News)



[Facebook.com/Rosemount](https://www.facebook.com/Rosemount)



[Youtube.com/user/RosemountMeasurement](https://www.youtube.com/user/RosemountMeasurement)



[Google.com/+RosemountMeasurement](https://plus.google.com/+RosemountMeasurement)

Standard Terms and Conditions of Sale can be found on the [Terms and Conditions of Sale page](#).

The Emerson logo is a trademark and service mark of Emerson Electric Co. Rosemount and Rosemount logotype are trademarks of Emerson. 3DMultiVision, THUM, Rosemount and Rosemount logotype are trademarks of Emerson Process Management.

Modbus is a registered trademark of Modicon, Inc.

HART is a registered trademark of FieldComm Group.

Intel is a trademark of Intel Corporation in the U.S. and/or other countries.

Microsoft is a registered trademark of Microsoft Corporation in the United States and other countries.

Windows is a trademark of Microsoft Corporation in the United States and other countries.

Excel is a registered trademark of Microsoft Corporation in the United States and other countries.

National Electrical Code is a registered trademark of National Fire Protection Association, Inc.

All other marks are the property of their respective owners.

© 2017 Emerson. All rights reserved.