

Rosemount™ 405 Compact Primary Element



NOTICE

This guide provides basic guidelines for Rosemount 405. It does not provide instructions for configuration, diagnostics, maintenance, service, troubleshooting, Explosion-proof, Flameproof, or intrinsically safe (I.S.) installations. Refer to the Rosemount 405 Reference Manual (document number 00809-0100-4810) for more instruction. This manual is also available electronically on www.rosemount.com.

If the Rosemount 405 was ordered assembled to a Rosemount 3051S Transmitter, the new assembly is the Rosemount 3051SFC Compact Flowmeter. See the following Quick Start Guide for information on configuration and hazardous locations certifications: Rosemount 3051S Series Pressure Transmitter (document number 00825-0100-4801).

If the Rosemount 405 was ordered assembled to a Rosemount 3051S MultiVariable™ Transmitter, the new assembly is the Rosemount 3051SFC Compact Flowmeter. See the following Quick Start Guide for information on configuration and hazardous locations certifications: 3051S MultiVariable Transmitter (document number 00825-0100-4803).

⚠ WARNING

Process leaks may cause harm or result in death.

To avoid process leaks, use only gaskets designed to seal with the corresponding flange and O-rings to seal process connections.

To ensure correct operation download the most current version of the Engineering Assistant software at:

EmersonProcess.com/en-US/brands/rosemount/Pressure/Pressure-Transmitters/MultiVariable-Transmitters/3051S-MultiVariable/engineering-assistant6/Pages/index.aspx.

Contents

Primary element location 3 Primary element installation 10
Primary element orientation 5 Product certifications 13

1.0 Primary element location

Install the Rosemount 405 in the correct location within the piping branch to prevent inaccurate measurement caused by flow disturbances.⁽¹⁾

Table 1. 405C Straight Pipe Requirements⁽¹⁾

	Beta	0.40	0.50	0.65
Upstream (inlet) side of primary	Reducer	2	2	2
	Single 90° bend or tee	2	2	2
	Two or more 90° bends in the same plane	2	2	2
	Two or more 90° bends in different planes	2	2	2
	Up to 10° of swirl	2	2	2
	Butterfly valve (75% to 100% open)	2	5	5
Downstream (outlet) side of primary		2	2	2

Table 2. 405P Straight Pipe Requirements⁽¹⁾⁽²⁾

	Beta	0.40	0.50	0.65
Upstream (inlet) side of primary	Reducer	5	8	12
	Single 90° bend or tee	16	22	44
	Two or more 90° bends in the same plane	10	18	44
	Two or more 90° bends in different planes	50	75	60
	Expander	12	20	28
	Ball/gate valve fully open	12	12	18
Downstream (outlet) side of primary		6	6	7

Table 3. 405 Straight Run Requirements⁽¹⁾

		Without straightening vane		With straightening vane ⁽³⁾	
	Annubar™ averaging pitot tube - sensor size 1	In plane ⁽⁴⁾	Out of plane ⁽⁴⁾	From disturbance	From straightening vane
Upstream (inlet) side of primary	Reducer	12	12	8	4
	Expander	18	18	8	4
	Single 90° bend or tee	8	10	8	4
	Two or more 90° bends in the same plane	11	16	8	4
	Two or more 90° bends in different planes	23	28	8	4
	Butterfly Valve (75–100% open)	30	30	8	4
	Ball/Gate Valve fully open	8	10	8	4
Downstream (outlet) side of primary		4	4	4	4

1. Consult an Emerson™ Process Management representative if a disturbance is not listed.
2. If using flow straighteners, refer to ISO 5167 for recommended links.
3. Use straightening vane to reduce the required straight run length.
4. In plane means the Rosemount 405 is in the same plane as the elbow. Out of plane means the bar is perpendicular to the plane of the upstream elbow. Refer to [Figure 1 on page 4](#).

Note

Recommended lengths are represented in pipe diameters. If longer lengths of straight run are available, position the Rosemount 405 so 80% of the pipe run is upstream and 20% is downstream.

Flow conditioners may be used to reduce the required straight run length, improving performance.

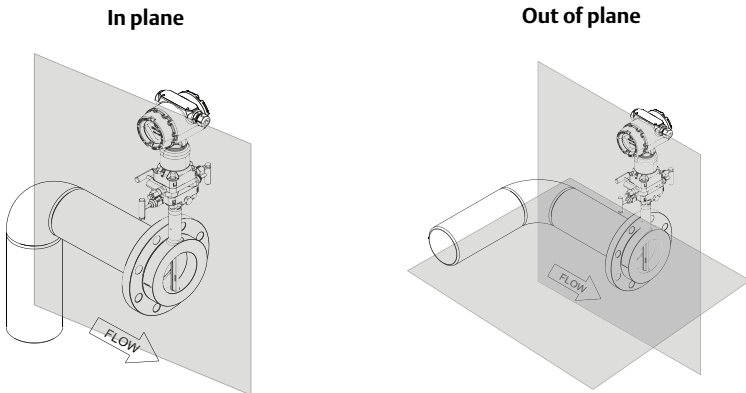
Figure 1. Compact Annubar Flowmeter In Plane and Out of Plane**Note**

The above figure depicts in plane and out of plane orientations only. Refer to [Table 3 on page 3](#) for recommended straight run requirements.

1.1 Vibration limits for Rosemount 405 products

Qualified per IEC61298-3 (2008) for field with general application or pipeline with low vibration level (10–1000 Hz test frequency range, 0,15 mm displacement peak amplitude, 20 m/s² acceleration amplitude)⁽¹⁾.

The weight and length of the transmitter assembly shall not exceed 9.8 lb (4,45 kg) and 8.60-in. (218,44 mm).

1. *Stainless steel temperature housing is not recommended with primary element technology A in applications with mechanical vibration.*

2.0 Primary element orientation

The primary element can be installed in any position around the circumference of the pipe, provided the vents are positioned properly for bleeding or venting. Optimal results for liquid or steam in a vertical line are obtained when flow is up.

Liquid - 405C, 405P, and 405A

Figure 2. Direct Mount

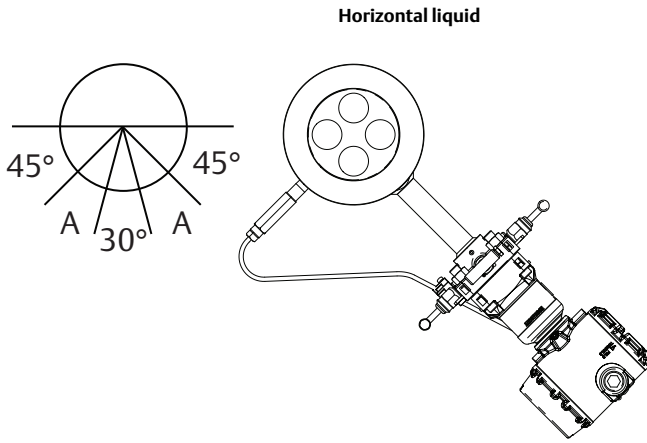

A. Recommended zone 30°

Figure 3. Remote Mount

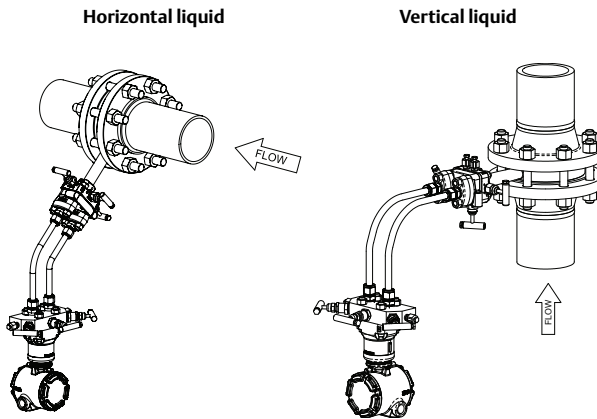

Gas - 405C, 405P, and 405A

Figure 4. Direct Mount

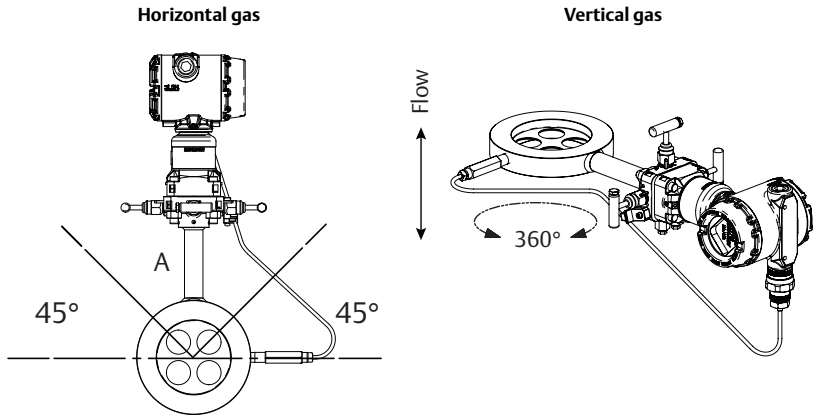

A. Recommended zone 90°

Figure 5. Remote Mount

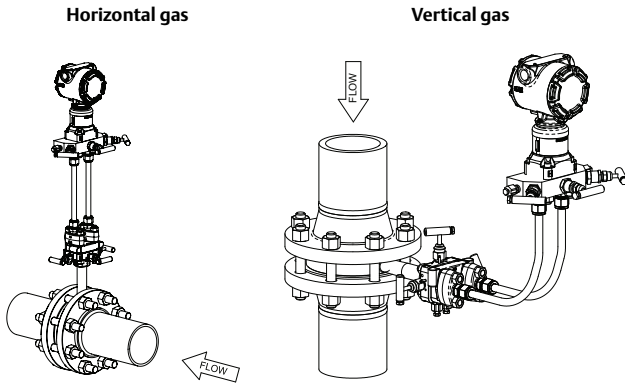

Steam - 405C, 405P, and 405A

Figure 6. Direct Mount

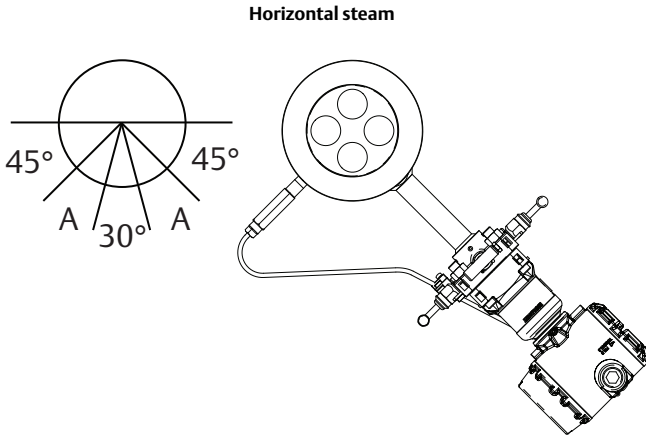

A. Recommended zone 30°

Figure 7. Remote Mount

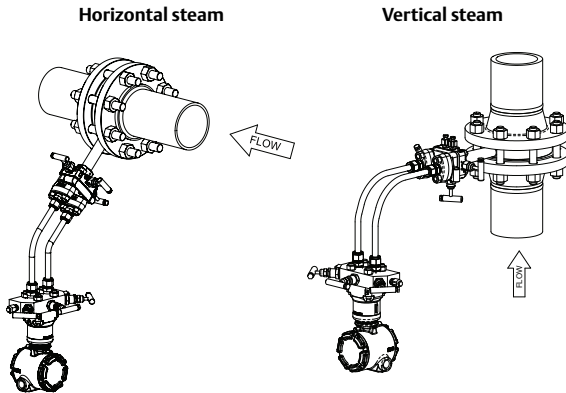

Note

For the Rosemount 405A model in steam applications, with DP readings in a low flow condition as low as 0.75 inH₂O in horizontal pipes consider installing the primary element/flowmeter in the top mounting for steam configuration.

Top mounting for steam

Top mounting in steam is an alternative mounting method for steam installations that can be used if there are space restrictions or other concerns. This installation method is intended for applications that run with limited interruptions or shutdowns. Also, for outdoor applications, top mounting can eliminate the need for heat tracing, if steam is flowing.

Figure 8. Direct mount — 405C, 405P, and 405A

Horizontal top mounting for steam up to 400 °F (204 °C)

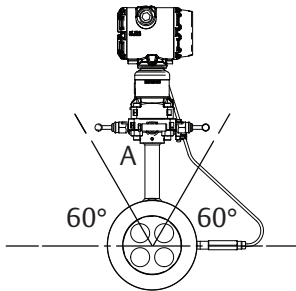

A. Recommended zone 60°

Note

For the Rosemount 405A Model in wet steam applications, do not mount the flowmeter at the direct vertical position. Mounting at an angle will avoid measurement inaccuracy due to water running along the bottom of the pipe.

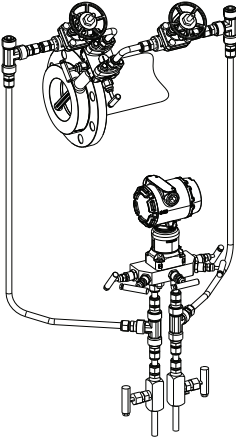
Figure 9. Remote mount up to 850 °F (454 °C) – 405C, 405P, and 405A

Note

When top mounting with a remote mount transmitter, use enough impulse piping to dissipate the process heat to avoid damaging the transmitter.

Suggested top mounting orientations:

- For steam up to 400 °F (204 °C) use direct mount orientation and for steam up to 850 °F (454 °C) use remote mount orientation.
- For direct mounting, ambient temperature should be less than 100 °F (38 °C).
- For remote mount installations, the impulse piping should slope up slightly from the instrument connections on the Rosemount 405A Model to the cross fittings, allowing condensate to drain back into the pipe.

From the cross fittings, the impulse piping should be routed downward to the transmitter and the drain legs. The transmitter should be located below the instrument connections of the Rosemount 405A Model.

For technologies C, P, and A, depending on the environmental conditions, it may be necessary to insulate the mounting hardware.

3.0 Primary element installation

1. Orient the assembly according to the guidelines provided in “Primary element orientation” on page 5. Ensure the flow arrow stamped on the 405 Primary Element is pointing in the same direction as the process flow.

Note

ANSI 150 - 600# alignment ring is included as standard when ordering for up to 8-in. line sizes. For the 10-in. and 12-in. line size, the alignment ring must be ordered (Installation Accessories). If a DIN or JIS alignment ring is required, it must be ordered as an option. Contact an Emerson Process Management sales representative for additional information.

Note

For ease of installation, the gasket may be secured to the flange face with small pieces of tape. Be sure the gasket or tape does not protrude into the pipe.

2. If using an alignment ring with through holes, proceed to [Step 9](#).
3. Insert two studs through the flange holes located opposite the head of the Rosemount 405.
4. Place the alignment ring on the Rosemount 405 body (see [Figure 10](#)).
5. Insert gaskets.
6. Insert the Rosemount 405 between the flanges so the indentations on the alignment ring contact the installed studs. The studs must contact the alignment ring in the indentation marked with the appropriate flange rating to ensure proper alignment.
7. Install remaining studs and nuts (hand tight). Ensure three of the studs are in contact with the alignment ring.
8. Lubricate studs and tighten nuts in a cross pattern to the appropriate torque per local standards.

[Step 9](#) through [Step 12](#) are for use with alignment rings that have through holes.

9. Place the alignment ring on the Rosemount 405 body (see “Horizontal gas” on page 6).
10. Insert the Rosemount 405 between the flanges.
 - a. Starting on the side opposite the Rosemount 405 head, rotate the alignment ring such that the radius corresponding to the alignment ring marking matches that of the application flange rating.
 - b. Insert one stud through both the upstream and downstream flanges and allow the ring to rest on the bolt. This will ensure proper alignment.
11. Repeat [Step 10](#) for the installation of the remaining bolts that will contact the alignment ring.
12. Insert gaskets.
13. Install remaining studs and nuts (hand tight). Ensure three of the studs are in contact with the alignment ring.
14. Lubricate studs and tighten nuts in a cross pattern to the appropriate torque per local standards.

Note

Standard $1/16$ -in. gaskets are recommended for use with the Rosemount 405. Using other gaskets could potentially cause a bias shift in the measurement.

3.1 Recommended insulation guidelines

For flowmeters with integral temperature assembly:

It is recommended that the meter be insulated when the difference between process and ambient temperature is greater than 30 °F (16.6 °C).

1. For line sizes $1/2$ -in. (15 mm) to 4-in. (100 mm), it is recommended to have 4-in. (100 mm) of insulation of at least a 4.35 R-factor.
2. For line sizes 6-in. (150 mm) to 12-in. (300 mm), it is recommended to have 5-in. (125 mm) of insulation of at least a 4.35 R-factor.

The full thickness stated above may not be necessary for the entire flowmeter, but is required for the temperature sensor area at a minimum. Insulation is needed to ensure meeting our specified temperature measurement accuracy. Insulation should only be placed up to the neck and not cover the transmitter.

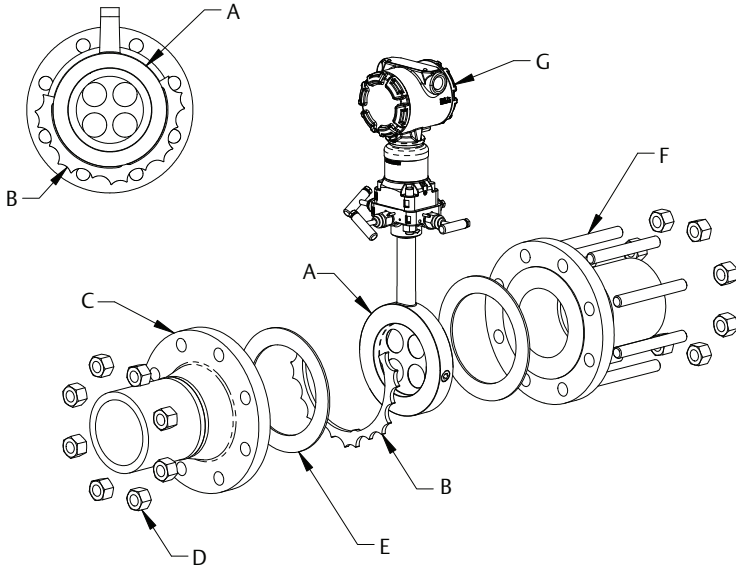
Figure 10. Rosemount 405 Installation

- | | |
|---------------------------------------|-------------------------------|
| A. Rosemount 405 ⁽¹⁾ | E. Gasket ⁽²⁾ |
| B. Alignment ring | F. Stud |
| C. Existing pipe assembly with flange | G. Transmitter ⁽²⁾ |
| D. Nut | |

1. This installation drawing applies to the 405C, 405P, and 405A.
2. The installation drawing applies when using the Rosemount 3051S, Rosemount 3051S MultiVariable, Rosemount 3051, and Rosemount 2051 Transmitter. See the following documents for quick installation instruction of the transmitter:
 Rosemount 3051S MultiVariable Transmitter: document number 00825-0100-4803
 Rosemount 3051S: document number 00825-0100-4801
 Rosemount 3051: document number 00825-0100-4001
 Rosemount 2051: document number 00825-0100-4101

4.0 Product certifications

4.1 Approved Manufacturing Locations

Rosemount Inc. – Chanhassen, Minnesota USA
Rosemount DP Flow Design and Operations – Boulder, Colorado USA
Emerson Process Management GmbH & Co. OHG – Wessling, Germany
Emerson Process Management Asia Pacific Private Limited – Singapore
Emerson Beijing Instrument Co., Ltd – Beijing, China

4.2 European Directive Information

The EC declaration of conformity for all applicable European directives for this product can be found on the website at EmersonProcess.com/Rosemount. A hard copy may be obtained by contacting our local sales office.

European Pressure Equipment Directive (PED) (97/23/EC)



Rosemount 405 Compact Primary Element — Sound Engineering Practice (SEP)
Pressure Transmitter — See appropriate Pressure Transmitter QSG.

4.3 Hazardous Locations Certifications

For information regarding the electronics product certification, see the appropriate transmitter Quick Start Guide:

- Rosemount 3051SMV: (document number 00825-0100-4803)
- Rosemount 3051S: (document number 00825-0100-4801)
- Rosemount 3051: (document number 00825-0100-4001)
- Rosemount 2051: (document number 00825-0100-4101)

Figure 11. Rosemount 405 Declaration of Conformity

	<h1>EU Declaration of Conformity</h1>	
<p>No: DSI 1000 Rev. L</p>		
<p>We,</p>		
<p>Rosemount, Inc. 8200 Market Boulevard Chanhassen, MN 55317-9685 USA</p>		
<p>declare under our sole responsibility that the products,</p>		
<p>Rosemount Primary Elements: 405x, 485, 585, 1195, 1495, 1595 Rosemount DP Flowmeters: 2051CFx, 3051CFx, 3051SFx</p>		
<p>manufactured by,</p>		
<p>Rosemount / Dieterich Standard, Inc. 5601 North 71st Street Boulder, CO 80301 USA</p>		
<p>to which this declaration relates, is in conformity with the provisions of the European Union Directives as shown in the attached schedule.</p>		
<p>Assumption of conformity is based on the application of the harmonized standards and, when applicable or required, a European Union notified body certification, as shown in the attached schedule.</p>		
	<p>Vice President of Global Quality (function)</p>	
<p>Kelly Klein (name)</p>	<p>19 Apr 2016 (date of issue)</p>	
<p>Page 1 of 3 DSI 1000.docx</p>		



EU Declaration of Conformity



No: DSI 1000 Rev. L

PED Directive (97/23/EC) This directive is valid until 18 July 2016
PED Directive (2014/68/EU) This directive is valid from 19 July 2016

Summary of Classifications		
Model/Range	PED Category	
	Group 1 Fluid	Group 2 Fluid
Rosemount 585 - 150#-900# All Lines	SEP	SEP
Rosemount 585 - 1500# & 2500# All Lines	III	SEP
Rosemount 405C, 405A, x051xFC	SEP	SEP
Rosemount 1195, x051xFP with 150#, 1-1/2" Flange	I	SEP
Rosemount 1195, x051xFP with 300# or 600#, 1" or 1-1/2" Flange	II	I
Rosemount 1195, x051xFP with 1" or 1-1/2" Threaded & Welded Connection	II	I
Rosemount 485/x051xFA: 1500# & 2500# All Line Sizes, Flanged	III	SEP
Rosemount 485/x051xFA: Sensor Size 2, 150#, 6"to 24" Line Sizes, FloTap	I	SEP
Rosemount 485/x051xFA: Sensor Size 2, 300#, 6"to 24" Line Sizes, FloTap	II	I
Rosemount 485/x051xFA: Sensor Size 2, 600#, 6"to 16" Line Sizes, FloTap	II	I
Rosemount 485/x051xFA: Sensor Size 2, 600#, 18"to 24" Line Sizes, FloTap	III	II
Rosemount 485/x051xFA: Sensor Size 3, 150#, 12"to 44" Line Sizes, FloTap	II	I
Rosemount 485/x051xFA: Sensor Size 3, 150#, 46"to 72" Line Sizes, FloTap	III	II
Rosemount 485/x051xFA: Sensor Size 3, 300#, 12" to 72" Line Sizes, FloTap	III	II
Rosemount 485/x051xFA: Sensor Size 3, 600#, 12" to 36" Line Sizes, FloTap	III	II
Rosemount 485/x051xFA: Sensor Size 3, 600#, 48" to 72" Line Sizes, FloTap	IV*	III
All other Rosemount Primary Elements and DP Flowmeters	SEP	SEP

Certificate of Assessment – CE-0041-H-RMT-001-13-USA

IV* Category IV Flo Tap requires a B1 Certificate for design examination and H1 Certificate for special surveillance



EU Declaration of Conformity



No: DSI 1000 Rev. L

Pressure Equipment Directive Notified Body:

Bureau Veritas UK Limited [Notified Body Number: 0041]
Parklands, Wilmslow Road, Didsbury
Manchester M20 2RE
United Kingdom

表格 1B: 含有 China RoHS 管控物质超过最大浓度限值的部件型号列表 Rosemount 405
Table 1B: List of Rosemount 405 Parts with China RoHS Concentration above MCVs

部件名称 Part Name	有害物质 / Hazardous Substances					
	铅 Lead (Pb)	汞 Mercury (Hg)	镉 Cadmium (Cd)	六价铬 Hexavalent Chromium (Cr +6)	多溴联苯 Polybrominated biphenyls (PBB)	多溴联苯醚 Polybrominated diphenyl ethers 多溴联苯醚 (PBDE)
铝制温度传感器外壳组件 Aluminum RTD Housing Assembly	O	O	O	X	O	O

本表格系依据 SJ/T11364 的规定而制作。

This table is proposed in accordance with the provision of SJ/T11364

O: 意为该部件的所有均质材料中该有害物质的含量均低于 GB/T 26572 所规定的限量要求。

O: Indicate that said hazardous substance in all of the homogeneous materials for this part is below the limit requirement of GB/T 26572.

X: 意为在该部件所使用的均质材料里，至少有一类均质材料中该有害物质的含量高于 GB/T 26572 所规定的限量要求。

X: Indicate that said hazardous substance contained in at least one of the homogeneous materials used for this part is above the limit requirement of GB/T 26572.

上述声明仅适用于选择铝制外壳组件的产品。其他所有差压流量一次元件的组件所含有的 China RoHS 管控物质浓度均低于 GB/T 26572 所规定的限量要求。关于差压流量计变送器组件的管控物质浓度的声明，请参看变送器的快速安装指南。

The disclosure above applies to units supplied with aluminum connection heads. No other components supplied with DP Flow primary elements contain any restricted substances. Please consult the transmitter Quick Start Guide (QIG) for disclosure information on transmitter components.



Global Headquarters

Emerson Process Management

6021 Innovation Blvd.
Shakopee, MN 55379, USA
+1 800 999 9307 or +1 952 906 8888
+1 952 949 7001
RFQ.RMD-RCC@EmersonProcess.com

North America Regional Office

Emerson Process Management

8200 Market Blvd.
Chanhassen, MN 55317, USA
+1 800 999 9307 or +1 952 906 8888
+1 952 949 7001
RMT-NA.RCCRFQ@Emerson.com

Latin America Regional Office

Emerson Process Management

1300 Concord Terrace, Suite 400
Sunrise, FL 33323, USA
+1 954 846 5030
+1 954 846 5121
RFQ.RMD-RCC@EmersonProcess.com

Europe Regional Office

Emerson Process Management Europe GmbH

Neuhofstrasse 19a P.O. Box 1046
CH 6340 Baar
Switzerland
+41 (0) 41 768 6111
+41 (0) 41 768 6300
RFQ.RMD-RCC@EmersonProcess.com

Asia Pacific Regional Office

Emerson Process Management Asia Pacific Pte Ltd

1 Pandan Crescent
Singapore 128461
+65 6777 8211
+65 6777 0947
Enquiries@AP.EmersonProcess.com

Middle East and Africa Regional Office

Emerson Process Management

Emerson FZE P.O. Box 17033,
Jebel Ali Free Zone - South 2
Dubai, United Arab Emirates
+971 4 8118100
+971 4 8865465
RFQ.RMTMEA@Emerson.com



Linkedin.com/company/Emerson-Process-Management



Twitter.com/Rosemount_News



Facebook.com/Rosemount



Youtube.com/user/RosemountMeasurement



Google.com/+RosemountMeasurement

Standard Terms and Conditions of Sale can be found at

www.Emerson.com/en-us/pages/Terms-of-Use.aspx

The Emerson logo is a trademark and service mark of Emerson Electric Co.

Annubar, Rosemount and Rosemount logotype are trademarks of Emerson Process Management.

All other marks are the property of their respective owners.

© 2016 Emerson Process Management. All rights reserved.