

Rosemount™ 3101, 3102, and 3105 Ultrasonic Liquid Level Transmitters



NOTICE

This installation guide provides basic guidelines for the Rosemount™ 3101, 3102, and 3105 Ultrasonic Level Transmitters. It does not provide instructions for detailed configuration, diagnostics, maintenance, service, troubleshooting, or installations. Refer to the Rosemount 3101, 3102 and 3105 [Reference Manual](#) for more instructions.

Manuals are available electronically on Emerson/Rosemount.com.

⚠ WARNING**Failure to follow these installation guidelines could result in death or serious injury**

- The Rosemount 3101, Rosemount 3102, and Rosemount 3105 are ultrasonic liquid level transmitters. They must be installed, connected, commissioned, operated, and maintained by suitably qualified personnel only, observing any national and local requirements that may apply
- Use the equipment only as specified. Failure to do so may impair the protection provided by the equipment

Explosions could result in death or serious injury

- Installation of the transmitters in a hazardous environment must be in accordance with the appropriate local, national, and international standards, codes, and practices. Please review the Product Certifications section for any restrictions associated with a safe installation
- Before connecting a Field Communicator in an explosive atmosphere, ensure the instruments are installed in accordance with intrinsically safe or non-incendive field wiring practices
- Verify that the operating atmosphere of the transmitter is consistent with the appropriate hazardous locations certifications

External surface may be hot

Care must be taken to avoid possible burns

Process leaks could result in death or serious injury

- Install and tighten process connectors before applying pressure
- Do not attempt to loosen or remove process connectors while the transmitter is in service

Electrical shock could cause death or serious injury

- Make sure that the transmitter is not powered when making connections
- If the liquid level switch is installed in a high voltage environment and a fault condition or installation error occurs, high voltage may be present on leads and terminals

The Rosemount 3101, 3102, and 3105

The Rosemount 3101, 3102, and 3105 are 4–20 mA loop-powered level transmitters designed for continuous liquid level measurements in tanks or open flow channels.

They can be connected directly to a plant control system, or used with a Rosemount 3490 Series Control Unit for programmable control functionality. The Rosemount 3105 may be mounted in a hazardous area if powered from a protected power supply.

1.0 Theory of operation

The transmitter is designed to be mounted above a liquid and uses ultrasonic pulses to continuously measure the distance to the liquid surface. The microprocessor-controlled electronics calculates distance to the liquid level from the time delay between the transmitting and receiving of signals.

When programmed with the bottom reference of the application – usually the bottom of a tank (Figure 1) – the transmitter calculates the liquid depth (level) and outputs the level as a 4–20 mA signal (and a digital HART® signal on the 3102 and 3105).

The 3101 measures level only. The 3102 and the 3105 can calculate distance-to-surface, contents (volume), or open channel flow, and then output the result as a 4–20 mA signal and a digital HART signal.

An LCD screen inside the enclosure displays the selected measurement.

Programming is achieved using integral buttons inside the enclosure (all models) or by remote communication using HART (on the 3102 and 3105 only).

Figure 1. Typical Application

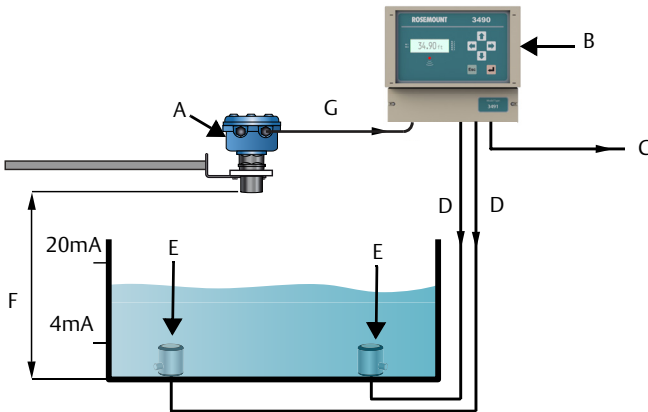

- | | |
|---------------------------------------|----------------------------|
| A. Rosemount 3100 Series Transmitter | E. Pump |
| B. Rosemount 3490 Series Control Unit | F. Bottom reference |
| C. 4–20 mA signal | G. 4–20 mA and HART signal |
| D. Relay | |
- HART is available on the Rosemount 3102 and Rosemount 3105.

Considerations before installation

The Rosemount 3100 Series may be used for level and volume measurement in open or closed tanks, or open channel flow measurement.

The glass-filled nylon housing version of the transmitter must be installed in a location where it is protected from ultraviolet radiation to prevent long term degradation of the plastics used e.g. shrouded from direct sunlight.

Note

See also “[Product certifications](#)” on page 24 for special conditions for safe use.

2.0 Safety considerations

1. Installation must be carried out by suitably trained personnel in accordance with the applicable code of practice.
2. If the equipment is likely to come into contact with aggressive substances, it is the responsibility of the user to take suitable precautions that prevent it from being adversely affected, thus ensuring that the type of protection is not compromised.

Aggressive substances are acidic liquids or gases that may attack metals or solvents that may affect polymeric materials.

Suitable precautions are regular checks as part of routine inspections, or establishing, from the material's datasheet, that it is resistant to specific chemicals.

3. The equipment must only be cleaned with a damp cloth; do not use solvents.
4. The equipment is not intended to be repaired by the user and is to be replaced by an equivalent certified unit. Repairs should only be carried out by the manufacturer or approved repairer.
5. The transmitter is *Double Insulated*, and therefore Protective Earthing is not required. The cable shield/screen should be connected to a suitable ground (earth) at one end only (see [“Connecting the cable\(s\) to the transmitter” on page 7](#)).
6. Note that if the equipment is used in a manner not specified by the manufacturer, the protection afforded by the equipment may be impaired.
7. To ensure electro-magnetic compatibility in any European member state, it should not be installed in a residential area.

Note

It is not advisable to mount the transmitter near to a source of electrical noise such as a variable-speed drive or other high-powered electrical device.

3.0 Environmental considerations

1. The Rosemount 3105 transmitter is Intrinsically Safe (IS) approved for hazardous area installations.
2. The 3101, 3102, and 3105 are designed for open or closed tank installation. They are weatherproof and protected against the ingress of dust.
3. Avoid installing the transmitters near heat sources.

Figure 2. Environmental Considerations

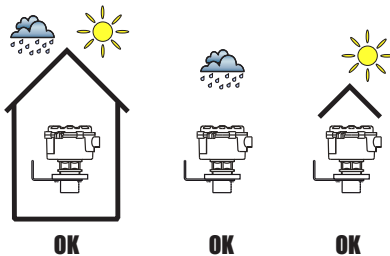

4.0 Mounting considerations

1. Mount the transmitter above the liquid using the 2-in. thread provided, but no closer than 12 in. (0,3 m) to the surface. The transmitter does not detect any liquid surface closer than 12 in. (0,3 m) to the transmitter face.
2. The transmitter should be mounted vertically to ensure a good echo from the liquid surface. The beam half angle is 6 degrees (see [Figure 7 on page 11](#)).
3. Obstructions in the tank, or well, may generate echoes which can be confused with the real liquid surface echo. Obstructions within the beam angle generate strong false echoes. Wherever possible, the transmitter should be positioned to avoid false echoes.
4. To avoid detecting unwanted objects in the tank or well, it is advisable to maintain a distance sideways of at least 1.3 in. from the center line of the transmitter for every foot (11 cm per meter) range to the obstruction ([Figure 7 on page 11](#)).
5. No false echoes are generated if the transmitter is located near the side of the tank or well on condition that the wall is smooth and free of protrusions. However, there will still be a reduction in the echo size. It is recommended that the transmitter be mounted no closer than 12 in. (0,3 m) to the wall to avoid a large reduction in the echo size.
6. If the transmitter is mounted in an enclosed tank with a domed top, avoid mounting the transmitter in the center of the tank roof because this could act as a parabolic reflector and create unwanted echoes.
7. Avoid applications where heavy condensation could form on the transmitter face.
8. If the transmitter is mounted in a stand-off or nozzle, the transmitter face should protrude at least 0.2 in. (5 mm) into the tank.
9. If the transmitter is used in environments where direct sunlight can cause high temperatures on exposed surfaces, a sun-shade is recommended.

Electrical installation

5.0 Connecting the cable(s) to the transmitter

The Rosemount 3100 Series is a two-wire loop-powered transmitter accepting power supplies as follows:

- The 3101: 12 to 30 Vdc
- The 3102: 12 to 40 Vdc
- The 3105: 12 to 40 Vdc (non-hazardous area), 12 to 30 Vdc (hazardous area)

Note

- To comply with the CSA approval requirements, the Rosemount 3101 and 3102 must be powered from a Rosemount 3490 Series Control Unit or a class 2 separate extra-low voltage (SELV) source.
 - Other devices may reset if connecting the transmitter to a multi-drop system while the loop is powered. De-energize the loop to avoid devices being reset.
-

Each transmitter is supplied with two cable entries. A suitable conduit system or cable gland must be used to maintain the weather-proof rating and hazardous area protection. Any unused entry must be sealed with a suitably rated blanking plug.

A two-core, shielded/screened cable is required for external power supply and output signal connections. The cable is not supplied.

5.1 Hazardous area installation (Rosemount 3105 only)

When the Rosemount 3105 is used with a Rosemount 3490 Series Control Unit, no additional safety barriers are required. If powering the Rosemount 3105 from any other source, ensure a suitable Intrinsically Safe (IS) barrier is fitted in the non-hazardous (safe) area.

The barrier must be chosen such that its output parameters U_o , I_o and P_o are less than U_i , I_i and P_i of the transmitter.

IS parameters: $U_i = 30\text{ V}$, $I_i = 120\text{ mA}$, $P_i = 0.82\text{ W}$, $L_i = 108\text{ mH}$, $C_i = 0\text{ nF}$

The sum of the capacitance and the inductance of the transmitter and the connecting cable must not exceed the maximum specified for the barrier chosen.

5.2 Connect the cable(s) to the transmitter

1. Make sure that the power supply is disconnected.
2. Undo the three cover screws and then lift the transmitter housing cover.
The cover on the metal housing can rest on the hinge. Place an object under the cover to avoid the transmitter toppling over.
3. Pass the cable through the cable gland/conduit.

4. Connect the cable wires:
 - a. For the 3101, connect wires according to the [Figure 3](#).
 - b. For the 3102, connect wires according to the [Figure 4](#).
 - c. For the 3105, connect wires according to the [Figure 5](#).
5. Connect the cable shield/screen to a suitable ground (earth) at one end only.
6. Replace the cover, tighten the cable gland, and connect the power supply.

Note

- The Rosemount 3101 and 3102 are not intrinsically safe and are for use in non-hazardous (Ordinary Location) installations only.
- If HART communications is required (available on the Rosemount 3102 and 3105), a 250 Ohm (minimum), 0.25 W load resistor must be installed in the loop. When using the Rosemount 3102 or 3105 transmitter with a Rosemount 3490 Series Control Unit, this resistor is not required.

Figure 3. Wiring Diagram for Rosemount 3101

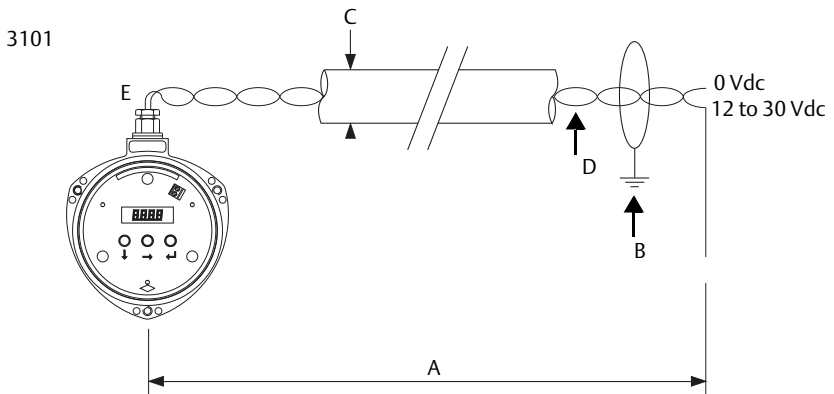

- A. Maximum cable length is 9750 ft. (3000 m)
- B. Connect the cable shield/screen to ground (earth) in the control room
- C. Cable thickness: $\text{Ø}0.15$ to 0.31 in. ($\text{Ø}4$ to 8 mm)
- D. Twisted-pair, screened wires
Minimum size: 0.22 mm^2 (24 SWG / 23 AWG); Maximum: 1.5 mm^2 (16 SWG / 18 AWG)
- E. Minimum of 12 Vdc is required at the transmitter for it to operate

Figure 4. Wiring Diagram for Rosemount 3102

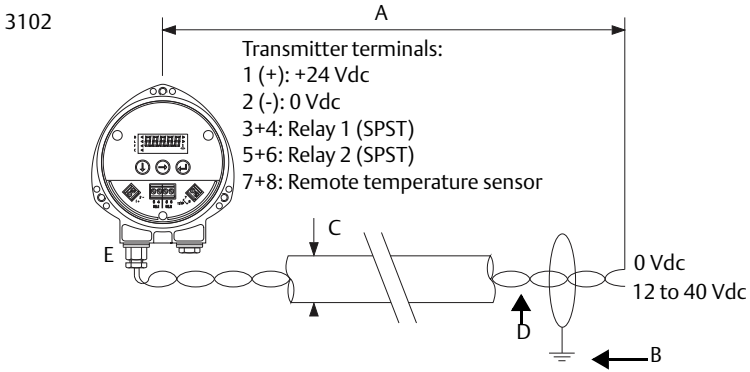

- A. Maximum cable length is 9750 ft. (3000 m)
- B. Connect the cable shield/screen to ground (earth) in the control room
- C. Cable thickness: \varnothing 0.15 to 0.31 in. (\varnothing 4 to 8 mm)
- D. Twisted-pair, screened wires
 Minimum size: 0.22 mm² (24 SWG / 23 AWG); Maximum: 1.5 mm² (16 SWG / 18 AWG)
- E. Minimum of 12 Vdc is required at the transmitter for it to operate

Figure 5. Wiring Diagram for Rosemount 3105

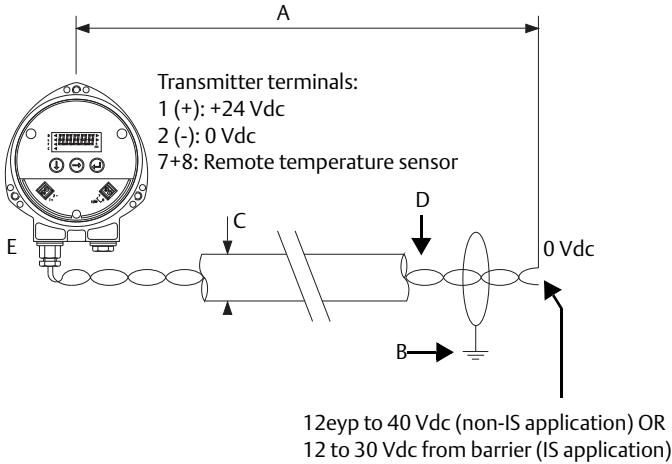

- A. Maximum cable length is 9750 ft. (3000 m)
- B. Connect the cable shield/screen to ground (earth) in the control room
- C. Cable thickness: \varnothing 0.15 to 0.31 in. (\varnothing 4 to 8 mm)
- D. Twisted-pair, screened wires
 Minimum size: 0.22 mm² (24 SWG / 23 AWG); Maximum: 1.5 mm² (16 SWG / 18 AWG)
- E. Minimum of 12 Vdc is required at the transmitter for it to operate

6.0 Mounting the transmitter above a liquid surface

A 2-in. thread is provided to mount the transmitter. The thread form is either BSPT or NPT, and is clearly marked on the hexagon of the transmitter body.

To help with an installation, flange accessories and bracket kits are available from Emerson. The accessory flanges supplied are manufactured from PVC and are a full face design. Care must be taken when installing to raised face mating flanges on the tank or vessel to prevent distortion of the PVC flange by over-tightening the bolts (see “[Installation instructions](#)” on page 11).

Refer to Rosemount 3101, 3102, and 3105 [Product Data Sheet](#) on Emerson/Rosemount.com for accessory ordering information.

6.1 Bracket mounting

The bracket kit contains a stainless steel angle bracket and PVC threaded disc ([Figure 6](#)), which may be used to mount the transmitter on a support over the liquid surface.

Installation instructions

1. Attach bracket to the disc using the three screws provided.
2. Attach the assembled bracket and disc to a rigid support over the liquid surface.
The bracket may be bolted to a suitable cross member. Ensure the transmitter is perpendicular to the surface to maximize the return echo size.
3. Use PTFE tape on the transmitter’s screw thread.
4. Insert the transmitter into the disc.
5. Tighten to a torque of 1.5 ft-lb (2 N-m) using the transmitter’s hexagon. Do not use the transmitter housing to tighten.

Figure 6. Bracket Mounting

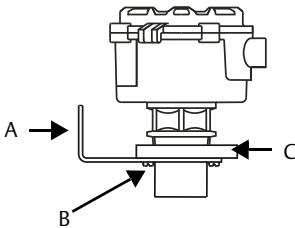

- A. Stainless steel bracket
B. No. 4X 13 long self tap screws (x3), carbon steel (zinc plated)
C. PVC disc
-

6.2 Installing in a tank with a nozzle or stand-off

Installation instructions

1. Use PTFE tape on the screw thread of the transmitter.
2. If the tank has a flanged nozzle or stand-off:
 - a. Attach the transmitter to a non-metal instrument flange using the threaded connection. Tighten to a torque of 1.5 lb-ft (2 N-m) using the transmitter's hexagon.
 - b. The instrument (accessory) flanges supplied by Emerson™ are manufactured from PVC and are a full face design. Care must be taken when installing to a raised face mating flange on the tank or vessel to prevent distortion of the PVC flange by over-tightening the bolts.
 - c. Ensure the gasket is sitting correctly on the nozzle/tank flange.
 - d. Lower the assembled transmitter and instrument flange onto the tank flange, and secure with appropriate bolting to a suitable torque for the flanges.

If mating to a raised face flange (RF) on the tank nozzle or stand-off, tighten to a maximum torque of 10 lb-ft (13.6 N-m).

3. If the tank has a threaded nozzle or stand-off:
 - a. Attach the transmitter to the nozzle/stand-off using the threaded connection.
 - b. Tighten to a torque of 1.5 lb-ft (2 N-m) using the transmitter's hexagon.

If the transmitter face does not protrude into the vessel, refer to the installation section in the [Reference Manual](#) for further information.

Figure 7. Flange Mounting

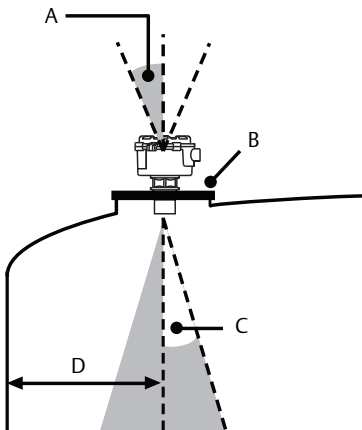

- A. Transmitter is mounted vertically (maximum deviation of 3°)
- B. Use non-metallic fitting or flange
- C. 6° Beam half angle
- D. 1.3 in./ft (11 cm/m), minimum of 12 in. (0,3 m)

6.3 Open channel flow installations

Mount an ultrasonic transmitter over an area of clear liquid. Avoid mounting the transmitter directly over any inlet stream. Never suspend the transmitter by the cable.

Positioning of the transmitter is critical and should be the correct distance upstream from the flow structure as stated in the relevant standard for your country.

For example, in the ISO standards, the distance should be four to five times the maximum height of the water (H_{max}) for a thin plate weir, or three to four times H_{max} for a flume. For optimum accuracy, the transmitter's front face should be positioned at a height equal to the sum of the maximum flow depth plus the transmitter dead band of 12.2 in. (300 mm) plus an extra 2 in. (50 mm).

Figure 8. Choosing the Height Position Above a Flow

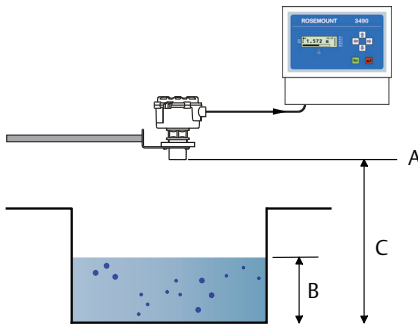

- A. Transmitter front face
- B. H_{max}
- C. Transmitter bottom reference = $H_{max} + 12.2 \text{ in. (300 mm)} + 2 \text{ in. (50 mm)}$

It is important that the bottom reference of the transmitter should be related to the datum of the primary measuring device (Figure 9).

Figure 9. Bottom Reference of a Flume or Weir

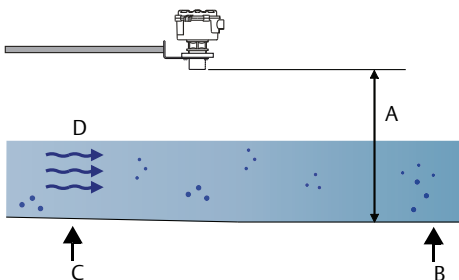

- A. Transmitter bottom reference
- B. Primary device (e.g. flume, weir) Invert
- C. Approach channel
- D. Flow direction

When setting the bottom reference on a 'V'-notch weir ([Figure 10](#)), it is important the true invert is used and not the meniscus level.

Figure 10. Bottom Reference of 'V'-notch Weir

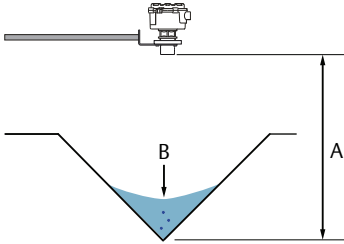

A. Transmitter bottom reference (i.e. true invert)

b. Meniscus level

Note

- The transmitter should be free from a situation where it is likely to 'drown' (refer to the relevant standard for further information).
- If the flow structure permits, mount the transmitter within the flow channel or chamber. Shroud the transmitter from direct sunlight for maximum accuracy and stability.
- The Rosemount 3102 and Rosemount 3105 have the option of a Remote Temperature Sensor (RTS). This temperature sensor should be mounted in a location where it can get an accurate air temperature measurement and is protected from sunlight. (See [Quick Installation Guide](#) for further RTS installation information).

Configuring the transmitter

Each transmitter can be configured and verified using the integral buttons. Alternatively, the Rosemount 3102 and Rosemount 3105 can be configured and verified using a Field Communicator, Rosemount 3490 Series Control Unit, or a PC running AMS Device Manager (see [Figure 11](#)).

The parameters described in this section are sufficient for a basic level application.

For menu maps and how to configure more advanced level, contents (volume), or open channel flow applications, refer to the Rosemount 3100 Series [Reference Manual](#).

Note

Transmitters are pre-configured for level measurement. It may not be necessary to proceed with this step unless needing to verify or change the settings.

Figure 11. System Architecture

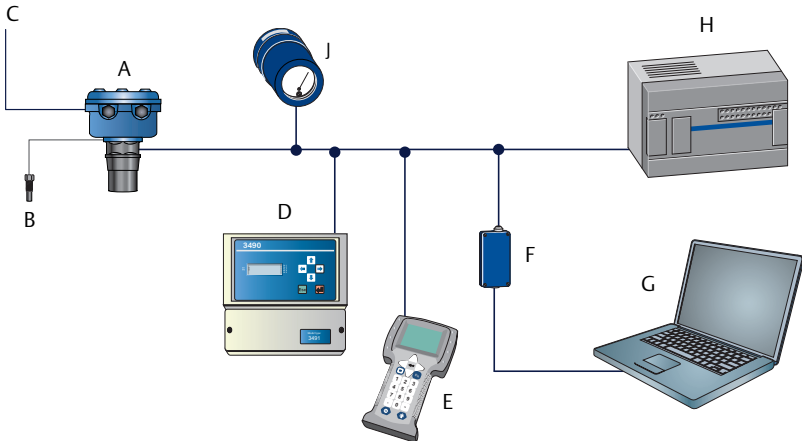

- A. Rosemount 3100 Series Transmitter
- B. Remote temperature sensor (optional accessory for the 3102 and 3105 only)
- C. Two relay outputs (on the Rosemount 3102 only)
- D. Rosemount 3490 Series Controller
- E. Field communicator
- F. HART modem
- G. AMS Device Manager
- H. Control system
- J. 751 Display

6.4 Transmitter base units

The Base Units for the Rosemount 3101 are always metric, but changing the Display Units re-scales the level measurement from meters-to-feet or meters-to-inches (see [page 19](#)).

When the Rosemount 3102 and 3105 are shipped from the factory, the default settings for Base Units are “metric” or “imperial ft” depending on the model order code.

Note (Rosemount 3102/3105 only)

Keep a record of your programmed settings. If the base units are changed on the Rosemount 3102 or 3105, the transmitter automatically re-starts as if it were a new instrument on first power-up, but will default to the chosen base units and load factory default values.

Method: Integral buttons

(The Rosemount 3101 always **operates** in meters. See [page 19](#) for how to change Display Units).

To change the Base Units on the Rosemount 3102 and 3105:

1. From the *PV display*, press the **blue button** → to indicate the “DiAg”.
2. Hold down the **blue button** → for two seconds and then release (“tEst” is displayed).
3. Hold down both the **blue button** → and **red button** ↵ for two seconds (“Eng” is displayed).
4. Press the **green button** ↓ to indicate the first engineering menu option “t.hoLd”.
5. Press the **green button** ↓ repeatedly until “b.unit” is indicated.
6. Press the **blue button** → to indicate the presently selected base units.
7. If these base units are correct, press the **red button** ↵.
(Press **green button** ↓ for the next menu and skip steps 8 to 11).
8. Press the **blue button** → to start the editing mode (present base units flash).
9. Press the **green button** ↓ repeatedly to scroll through the three options.
10. Press the **blue button** → to confirm the selected base units (flashing stops).
11. Press the **red button** ↵ to save. (The transmitter automatically re-starts as if it was a new instrument on first power-up). Otherwise, press the **blue button** → to not save.

Method: Field Communicator or AMS Device Manager

To view or change the Base Units:

1. From the *Home* screen, select **3: Service Tools**.
2. Select **4: Maintenance**.
3. Select **3: Utilities**.
4. Select **3: Set Base Units**.
5. Select new base units.

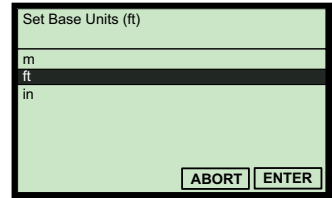

(Field Communicator Screen Shown)

Method: Rosemount 3490 Series Control Unit

To view or change the Base Units:

1. From the *Main Menu* screen, select **SETUP**.
2. Select the transmitter (e.g. "Tx1: 3102").
3. Select **SYSTEM**, and then select **Base Units**.
4. Select new base units.

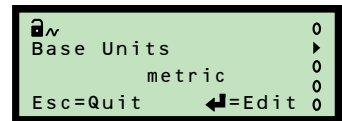

(Rosemount 3491 Screen Shown)

To get the same base units on the control unit, switch the power off and then on again. The control unit prompts for the transmitter's Bottom Reference value in the new base units.

6.5 Transmitter bottom reference

Note

This parameter is important for calibrating and configuring the transmitter.

On the Rosemount 3101, the transmitter's Bottom Reference setting is the distance measured vertically along the ultrasonic beam path from the Transmitter Face to the Zero Level of a tank or an open channel (see [Figure 12 on page 22](#)).

On the Rosemount 3102 and 3105, it is the distance measured vertically along the ultrasonic beam path from the User Preferred Sensor Reference Point (UPSRP) to the Zero Level of a tank or an open channel (see [Figure 13 on page 23](#)).

The zero level establishes where the transmitter starts to measure the process value. It is not necessary to have the 4 mA output start at the zero level. The 4 mA starting point can be any liquid height above or below this zero level.

Method: Integral buttons

To view or change the Bottom Reference (**b.rEF**) setting:

1. From the *PV display*, press the **green button** ↓ to indicate “b.rEF”.
2. Press the **blue button** → to indicate the present b.rEF value.
3. If this value is correct, press the **red button** ↵ and then the **green button** ↓ to get to the next menu. Otherwise, continue with step (4).
4. Press the **blue button** → to start editing (first digit flashes).
5. Use the **green button** ↓ to edit the flashing digit.
6. Press the **blue button** → to move to the next digit (that digit flashes).
7. Repeat steps (5) and (6) until the last digit is flashing and edited as required.
8. Press the **blue button** → to confirm the new b.rEF value (no digits flashing).
9. Press the **red button** ↵ to save the new value, or press the **blue button** → to not save. Afterwards, depending on the action taken, either the “b.rEF” menu or the next menu appears.

Method: Field Communicator or AMS Device Manager

To view or change the Bottom Reference:

1. From the *Home* screen, select **2: Configure**.
2. Select **2: Manual Setup**.
3. Select **1: Basic Setup**.
4. Select **2: Bottom Reference P010**.
5. Input the new bottom reference and press **ENTER** to save it.
6. Press **SEND** to update the transmitter.

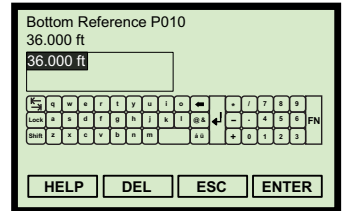

(Field Communicator Screen Shown)

Method: Rosemount 3490 Series Control Unit

To view or change the Bottom Reference:

1. From the *Main Menu* screen, select **SETUP**.
2. Select the transmitter (e.g. “Tx1: 3102”).
3. Select **DUTY** and then select **Bottom Ref.**
4. Follow the on-screen instructions to input and save the new setting.

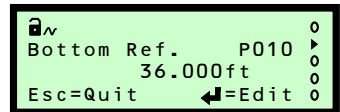

(Rosemount 3491 Screen Shown)

6.6 Transmitter duty / tank shape P011 / non-linear profile P011

The instructions here are for selecting level measurement on the Rosemount 3102 and 3105. The Rosemount 3101 duty is always level measurement.

For advanced applications, refer to the Rosemount 3100 Series [Reference Manual](#).

Method: Integral buttons

To change or view the duty:

1. From the *PV display*, press the **green button** ↓ to indicate “duty”.
2. Press the **blue button** → to display the presently selected duty.
3. If the duty is “LEVEL”, press the **red button** ↵ and then the **green button** ↓ to get to the next menu. Otherwise, continue with step (4).
4. Press the **blue button** → to start the editing mode (duty flashes).
5. Press the **green button** ↓ repeatedly until “LEVEL” appears.
6. Press the **blue button** → to confirm the duty (flashing stops).
7. Press the **red button** ↵ to save the duty setting, or press the **blue button** → to not save. Afterwards, depending on the action taken, either the “duty” menu or the next menu appears.

Method: Field Communicator or AMS Device Manager

To change the tank shape / non linear profile:

1. From the *Home* screen, select **2: Configure**.
2. Select **2: Manual Setup**.
3. Select **3: Profiling**.
4. Select **2: Set Non-Linear Profile**.
5. Select Linear and then press **ENTER** to save the selection.
6. Press **SEND** to update the transmitter.
7. The selected profile can be viewed at Fast Key sequence 2, 2, 3, 3.

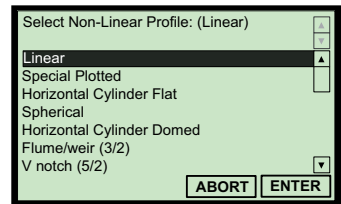

(Field Communicator Screen)

Note

When on-screen messages appear, take appropriate action if needed and press “OK”.

Method: Rosemount 3490 Series Control Unit

To change the tank shape / non linear profile:

1. From the *Main Menu* screen, select **SETUP**.
2. Select the transmitter (e.g. "Tx1: 3102").
3. Select **DUTY** and then select **Tank Shape**.
4. Follow the on-screen instructions to select Linear and save the new setting.

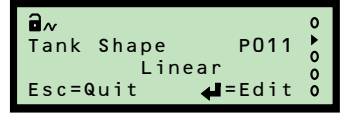

(Rosemount 3491 Screen)

6.7 Transmitter display units / primary variable units (P012)

On the Rosemount 3101, display units are indicated by the position of the decimal point in the displayed PV value i.e. 8.000 (m), 26.24 (ft.), or 314.9 (in.). The 3101 measures and calculates in meters. The measured value is converted into the selected display units using a pre-programmed conversion factor.

On the Rosemount 3102 and 3105, selecting new display units does not automatically re-scale the PV value. Either use the parameter Transmitter Scale Factor (page 20) to manually re-scale the PV value into appropriate units, or use base units which automatically changes the display units to meters, feet, or inches.

Method: Integral buttons

To change Display Units on the Rosemount 3101:

1. Starting from the *PV display*, hold down the **blue button** → and do not release it. After 10 seconds, the displayed units change according to the following sequence:
 3101****SC**: Meters to Feet, Feet to Inches, and Inches to Meters
 3101****RC**: Feet to Inches, Inches to Meters, and Meters to Feet
2. Continue to hold down the **blue button** → to cycle through units every three seconds.
3. Confirm the display units by releasing the **blue button** →.

To change Display Units on the Rosemount 3102 and 3105:

1. From the *PV display*, press the **green button** ↓ repeatedly until the "b.unit" is indicated.
2. Press the **blue button** → to indicate the presently selected units on the bottom line.
3. If the units are correct, press the **red button** ↵ and then the **green button** ↓ to get to the next menu. Otherwise, continue with step (4).
4. Press the **blue button** → to start the editing mode (*present units flash*).
5. Press the **green button** ↓ repeatedly to scroll through the list of units.
6. Press the **blue button** → to confirm the new units. The flashing stops.

- Press the **red button** \downarrow to save the setting. (The display momentarily goes blank, and then all the segments of the display will briefly show as the transmitter initiates a soft-start). Otherwise press the **blue button** \rightarrow to not save.
- Afterwards, depending on the action taken in step (7), either the “b.unit” menu or the next menu appears.

Method: Field Communicator or AMS Device Manager

To change the PV Units:

- From the *Home* screen, select **2: Configure**.
- Select **2: Manual Setup** and then select **3: Profiling**.
- Select **1: Primary Variable Units P012**.
- Select new units and then press **ENTER** to save.
- Press **SEND** to update the transmitter.

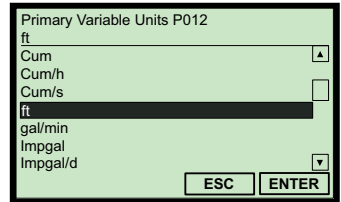

(Field Communicator Screen)

Method: Rosemount 3490 Series Control Unit

To change the PV Units:

- From the *Main Menu* screen, select **SETUP**.
- Select the transmitter (e.g. “Tx1: 3102”).
- Select **UNITS** and then select **PV Units**.
- Follow the on-screen instructions to select and confirm the new setting.

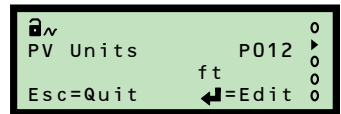

(Rosemount 3491 Screen)

6.8 Transmitter Scale Factor P013 / PV Scale Factor P013

On the Rosemount 3102 and 3105, this parameter converts the level measurement into alternative units before being output. Enter a value of 1.0 unless the base units are different to the displayed units, or the required display units could not be selected.

Method: Integral buttons

To view or change the scale factor:

- From the *PV display*, press the **green button** \downarrow repeatedly until the “SCALE” is indicated.
- Press the **blue button** \rightarrow to display the present scale factor.
- If the scale factor is correct, press the **red button** \downarrow and then the **green button** \downarrow to get to the next menu. Otherwise, continue with step (4).
- Press the **blue button** \rightarrow to start the editing mode (first digit flashes).
- Press the **green button** \downarrow repeatedly to edit the flashing digit.
- Press the **blue button** \rightarrow to move to the next digit (that digit flashes).

7. Repeat steps (5) and (6) until the last digit is flashing and edited as required.
8. Press the **blue button** → to confirm the new value (flashing stops).
9. Press the **red button** ↵ to save the new value, or press the **blue button** → to not save. Afterwards, depending on the action taken, either the “SCALE” menu or the next menu appears.

Method: Field Communicator or AMS Device Manager

To view or change the scale factor:

1. From the *Home* screen, select **2: Configure**.
2. Select **2: Manual Setup**.
3. Select **3: Profiling**.
4. Select **4: Scale Factor P013**.
5. Input the factor and press **ENTER** to save it.
6. Press **SEND** to update the transmitter.

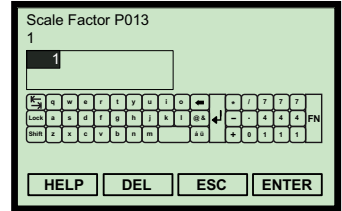

(Field Communicator Screen)

Method: Rosemount 3490 Series Control Unit

To view or change the scale factor:

1. From the *Main Menu* screen, select **SETUP**.
2. Select the transmitter (e.g. “Tx1: 3102”).
3. Select **DUTY** and then select **PV Scale Factor**.
4. Follow the on-screen instructions to edit and save the new factor.

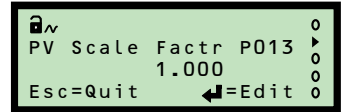

(Rosemount 3491 Screen Shown)

6.9 4 mA and 20 mA output (on the Rosemount 3101 only)

The process value (e.g. liquid level) is indicated by the 4–20 mA output.

Method: Integral buttons

To change the level at 4 mA:

1. From the *PV display*, press the **green button** ↓ repeatedly until “4” is shown.
2. Press the **blue button** → to indicate the present value of the 4 mA level.
3. If this value is correct, press the **red button** ↵ and then the **green button** ↓ to get to the next menu. Otherwise, continue with step (4).
4. Press the **blue button** → to start editing (the first digit flashes).
5. Press the **green button** ↓ repeatedly to edit the flashing digit.
6. Press the **blue button** → to move to the next digit (that digit flashes).
7. Repeat steps (5) and (6) until the last digit is flashing and edited as required.
8. Press the **blue button** → to confirm the new 4 mA level (no flashing digits).
9. Press the **red button** ↵ to save the new 4 mA level, or press the **blue button** → to not save. Afterwards, depending on the action taken, either the “4” menu or the next menu appears.

To change the level at 20 mA:

1. From the *PV display*, press the **green button** ↓ repeatedly until “20” is shown.
2. Press the **blue button** → to indicate the present value of the 20 mA level.
3. If this value is correct, press the **red button** ↵ and then the **green button** ↓ to get to the next menu. Otherwise, continue with step (4).
4. Press the **blue button** → to start editing (the first digit flashes).
5. Press the **green button** ↓ repeatedly to edit the flashing digit.
6. Press the **blue button** → to move to the next digit (that digit flashes).
7. Repeat steps (5) and (6) until the last digit is flashing and edited as required.
8. Press the **blue button** → to confirm the new 20 mA level (no flashing digits).
9. Press the **red button** ↵ to save the new 20 mA level, or press the **blue button** → to not save. Afterwards, depending on the action taken, either the “20” menu or the next menu appears.

Figure 12. Tank Geometry (on the Rosemount 3101 only)

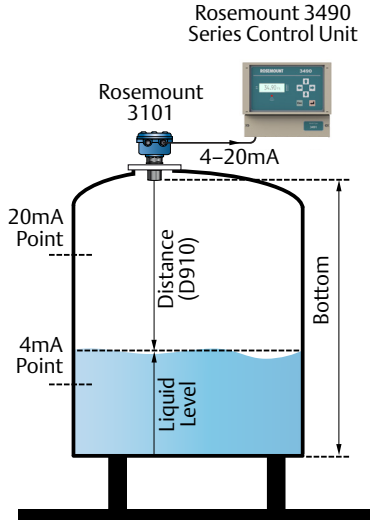

Note

The 4 mA level may be set above or below the 20 mA level.

6.10 HART and 4–20 mA output (Rosemount 3102 and 3105 only)

The process value (e.g. level) is indicated by the HART Primary Variable (D900).

Figure 13. Tank Geometry (Rosemount 3102 and 3105 only)

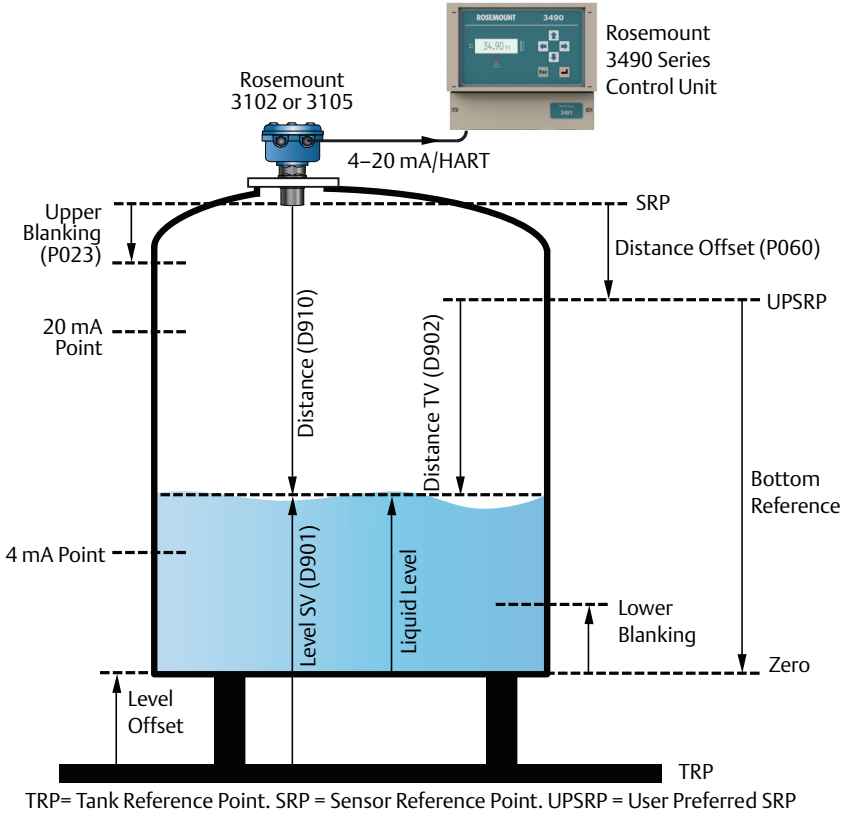

Table 1. Tank Geometry Parameters (Figure 12)

Parameter	Fast key	Rosemount 3490 Series menu navigation
Lower Blanking (P063)	2, 2, 5, 6	SETUP,[Tag], ENGINEERING, Lower Blanking
Upper Blanking (P023)	2, 2, 5, 5	SETUP,[Tag], ENGINEERING, Upper Blanking
Distance Offset (P060)	2, 2, 2, 2	SETUP,[Tag], DUTY, Distance Offset
Level Offset (P069)	2, 2, 2, 4	SETUP,[Tag], DUTY, Level Offset
20 mA Point ⁽¹⁾	2, 2, 1, 3	SETUP, [Tag], OUTPUT, CURRENT, Upper Range Val.
4 mA Point ⁽¹⁾	2, 2, 1, 4	SETUP, [Tag], OUTPUT, CURRENT, Lower Range Val.
Primary Variable (D900)	1, 2, 1	MONITOR,[Tag], READINGS, VARIABLES, Primary Variable
Level SV (D901)	1, 2, 2	MONITOR,[Tag], READINGS, VARIABLES, Level SV
Distance TV (D902)	3, 2, 1, 3	MONITOR,[Tag], READINGS, VARIABLES, Distance TV
Distance (D910)	3, 1, 2, 1, 1	MONITOR,[Tag], DIAGNOSTICS, Distance

1. Configure this parameter if not communicating HART variables (PV, SV, TV, and FV) to a Host.

Product certifications

⚠ WARNING

Potential electrostatic charging hazard

- To prevent the risk of electrostatic sparking, the surface of the glass-filled nylon (plastic) enclosure should only be cleaned with a damp cloth.
- Do not directly install in any process where its enclosure might be charged by the rapid flow of non-conductive media.

7.0 European Union directive information

The EU Declaration of Conformity begins on [page 28](#) and the most recent revision can be found at Emerson/Rosemount.com.

Note

A safety isolator such as a zener barrier is needed for intrinsic safety.

8.0 Factory Mutual (FM) approvals

Factory Mutual (FM) ordinary location approval (on the Rosemount 3101 and 3102 Only)

G5 Project ID: 3024095

The transmitter has been examined and tested to determine that the design meets basic electrical, mechanical, and fire protection requirements by FM, a nationally recognized testing laboratory (NRTL) as accredited by the Federal Occupational Safety and Health Administration (OSHA).

Factory Mutual (FM) intrinsically safe approval (on the Rosemount 3105 only)

I5 Project ID: 3024095

Intrinsically Safe for Class I, Division 1, Groups A, B, C, and D
 Zone Marking: Class I, Zone 0, AEx ia IIC
 Temperature Code: T6 ($T_a = 55^\circ\text{C}$)
 Temperature Code: T4 ($T_a = 60^\circ\text{C}$)
 Control Drawing: 71097/1216
 $U_i = 30\text{ V}$, $I_i = 120\text{ mA}$, $P_i = 0.82\text{ W}$, $L_i = 108\text{ }\mu\text{H}$, $C_i = 0\text{ nF}$.

Factory Mutual (FM) non-incendive approval (on the Rosemount 3105 only)

I5 Project ID: 3024095

Non-Incendive for Class I, Division 2, Groups A, B, C, and D
 Zone Marking: Class I, Zone 2, AEx nA IIC
 Temperature Code: T6 ($T_a = 55^\circ\text{C}$)
 Temperature Code: T4 ($T_a = 60^\circ\text{C}$)
 Control Drawing: 71097/1216
 $U_i = 30\text{ V}$, $I_i = 120\text{ mA}$, $P_i = 0.82\text{ W}$, $L_i = 108\text{ }\mu\text{H}$, $C_i = 0\text{ nF}$

9.0 Canadian Standards Association (CSA) approvals

Canadian Standards Association (CSA) ordinary location approval (on the Rosemount 3101 and 3102 only)

G6 Project ID: 02 CSA 1871624

The transmitter has been examined and tested to determine that the design meets basic electrical, mechanical, and fire protection requirements by CSA, a nationally recognized testing laboratory as accredited by the Standards Council of Canada (SCC).

Special Condition For Safe Use:

The power for the 3101 and 3102 must be supplied from a Rosemount 3490 Series Control Unit or a class 2 separate extra-low voltage (SELV) source.

Canadian Standards Association (CSA) intrinsically safe approval (on the Rosemount 3105 only)

I6 Project ID: 02 CSA 1352094

Intrinsically Safe for Class I, Division 1, Groups A, B, C, and D

Zone Marking: Class 1, Zone 0, Ex ia IIC

Temperature Code: T4 ($T_a = -40$ to 60 °C)

Temperature Code: T6 ($T_a = -40$ to 55 °C)

Control Drawing: 71097/1218

$U_i = 30$ V, $I_i = 120$ mA, $P_i = 0.82$ W, $L_i = 108$ μ H, $C_i = 0$ nF

Canadian Standards Association (CSA) non-incendive approval (on the Rosemount 3105 only)

I6 Project ID: 02 CSA 1352094

Non-Incendive for Class I, Division 2, Groups A, B, C, and D

Zone Marking: Class I, Zone 2, Ex nL IIC

Temperature Code: T4 ($T_a = -40$ to 60 °C)

Temperature Code: T6 ($T_a = -40$ to 55 °C)

Control Drawing: 71097/1218

$U_i = 30$ V, $I_i = 120$ mA, $P_i = 0.82$ W, $L_i = 108$ μ H, $C_i = 0$ nF

Note

A safety isolator such as a zener barrier is needed for intrinsic safety.

WARNING

Potential electrostatic charging hazard

- To prevent the risk of electrostatic sparking, the surface of the glass-filled nylon (plastic) enclosure should only be cleaned with a damp cloth.
- Do not directly install in any process where its enclosure might be charged by the rapid flow of non-conductive media.

10.0 ATEX intrinsically safe approval (on the Rosemount 3105 only)

- I1** Certificate: Sira 06ATEX2260X
ATEX Intrinsic Safety
II 1 G, Ex ia IIC T6 Ga (Ta = -40 to 55 °C)
II 1 G, Ex ia IIC T4 Ga (Ta = -40 to 60 °C)
Ui = 30 V, li = 120 mA, Pi = 0.82 W, Li = 108µH, Ci = 0 nF

11.0 NEPSI China intrinsically safe approval (on the Rosemount 3105 only)

- I3** Certificate: GYJ081008X
NEPSI Intrinsic Safety
Ex ia IIC T6 (Ta = -40 to 55 °C)
Ex ia IIC T4 (Ta = -40 to 60 °C)
Ui = 30 V, li = 120 mA, Pi = 0.82 W, Li = 108µH, Ci = 0 nF

12.0 IECEx intrinsically safe approval (on the Rosemount 3105 only)

- I7** Certificate: IECEx SIR 06.0068X
IECEx Intrinsic Safety
Zone 0, Ex ia IIC T6 Ga (Ta = -40 to 55 °C)
Zone 0, Ex ia IIC T4 Ga (Ta = -40 to 60 °C)
Ui = 30 V, li = 120 mA, Pi = 0.82 W, Li = 108µH, Ci = 0 nF

ATEX and IECEx conditions for safe use (I1 and I7):

Model numbers covered: 3105*****I1**** and 3105*****I7****
(* indicates options in construction, function and materials).

The following instructions apply to equipment covered by certificates numbered

SIRA 06ATEX2260X and IECEx SIR 06.0068X:

1. The equipment may be used with flammable gases and vapors with apparatus groups IIA, IIB, and IIC, and with temperature classes T1, T2, T3, T4, T5, and T6.
2. Installation of this equipment shall be carried out by suitably trained personnel, in accordance with the applicable code of practice.
3. The equipment is not intended to be repaired by the user and is to be replaced by an equivalent certified unit. Repairs should only be carried out by the manufacturer or approved repairer.
4. If the equipment is likely to come into contact with aggressive substances, it is the responsibility of the user to take suitable precautions that prevent it from being adversely affected, thus ensuring that the type of protection is not compromised.

Aggressive Substances: e.g. acidic liquids or gases that may attack metals or solvents that may affect polymeric materials.

- Suitable Precautions: e.g. regular checks as part of routine inspections or establishing from a material's data sheet if it is resistant to specific chemicals.
- The metallic alloy used for the enclosure material may be accessible at the surface of this equipment. In the event of rare accidents, ignition sources due to impact and friction spark could occur. This shall be considered when the Rosemount 3105 is installed in locations that specifically require Equipment Protection Level Ga (IECEX: zone 0) (ATEX: group II, category 1G) equipment.
5. The apparatus electronics is only certified for use in ambient temperatures in the range of -40 to 60 °C (T4) or -40 to 55 °C (T6). It should not be used outside this range.
 6. It is the responsibility of the user to ensure:
 - a. The voltage and current limits for this equipment are not exceeded.
 - b. That only suitably certified cable entry devices will be utilized when connecting this equipment.
 - c. That any unused cable entries are sealed with suitably certified stopping plugs.
 7. The Rosemount 3105 meets the requirements of clause 6.3.12 (isolation of circuits from earth or frame) in IEC 60079-11:2006 (EN 60079-11:2007).
 8. Technical Data:
 - a. Materials of construction:
 Probe: PVDF
 Housing and cover: stainless steel, aluminum alloy, or glass-filled nylon
 Cover seal: Silicone
 Nylon cable glands and blanking plugs
 - b. Coding:
 - ATEX: II 1 G, Ex ia IIC T4 Ga ($T_a = -40$ to 60 °C)
 - II 1 G, Ex ia IIC T6 Ga ($T_a = -40$ to 55 °C)
 - IECEX: Ex ia IIC T6 Ga ($T_a = -40$ to 55 °C)
 - Ex ia IIC T4 Ga ($T_a = -40$ to 60 °C)
 - c. Electrical: $U_i = 30$ V, $I_i = 120$ mA, $P_i = 0.82$ W, $L_i = 108$ μ H, $C_i = 0$ μ F
 - d. Year of manufacture: printed on the product label
 9. Special conditions for safe use:
 - a. The equipment must not be installed directly in any process where the enclosure might be charged by the rapid flow of non-conductive media.
 - b. The equipment must only be cleaned with a damp cloth.
 10. Manufacturer:
 Rosemount Measurement Limited, 158 Edinburgh Avenue, Slough,
 Berkshire, SL1 4UE, UK

Figure 14. EU Declaration of Conformity (page 1)





	
EU Declaration of Conformity No: RMD 1062 Rev. E	
<p>We,</p> <p>Rosemount Measurement Limited 158 Edinburgh Avenue, Slough, Berkshire, SL1 4UE United Kingdom</p> <p>declare under our sole responsibility that the product,</p> <p style="text-align: center;">Rosemount 3100 Series Ultrasonic Level Transmitter (3101, 3102, 3105)</p> <p>manufactured by,</p> <p>Rosemount Measurement Limited 158 Edinburgh Avenue, Slough, Berkshire, SL1 4UE United Kingdom</p> <p>to which this declaration relates, is in conformity with the provisions of the European Community Directives, including the latest amendments, as shown in the attached schedule.</p> <p>Assumption of conformity is based on the application of the harmonized standards and, when applicable or required, a European Community notified body certification, as shown in the attached schedule.</p>	
 _____ (signature)	Global Approvals Manager _____ (function)
David J Ross-Hamilton _____ (name)	4/20/2016 _____ (date of issue)
ROSEMOUNT	Page 1 of 3

Figure 14. EU Declaration of Conformity (page 2)

 **EU Declaration of Conformity** 

No: RMD 1062 Rev. E

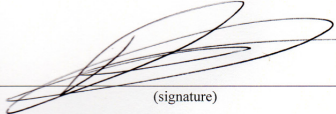
EMC Directive (2014/30/EU)

Model 3102HF**NA****, 3105H**F**I******
Harmonized Standards: EN 61326-1:2013, EN 61326-2.3:2013

Model 3101LF**NA****
Harmonized Standards: EN 61326-1:2013, EN 61326-2.3:2013
Class A (Industrial Radiated Emission limits)

ATEX Directive (2014/34/EU)

Model 3105HF**I******

Sira 06ATEX2260X – Intrinsically safe
Equipment Group II, Category 1 G (Ex ia IIC T4/T6 Ga)
Harmonized Standards: EN 60079-11:2012, EN 60079-26:2007
Other Standards Used: IEC 60079-0:2011

(Minor variations in design to suit the application and/or mounting requirements are identified by alpha/numeric characters where indicated * above)

ROSEMOUNT

Page 2 of 3

Figure 14. EU Declaration of Conformity (page 3)

EMERSON.

EU Declaration of Conformity

No: RMD 1062 Rev. E

ATEX Notified Body

Baseefa [Notified Body Number: 1180]
Rockhead Business Park, Staden Lane
Buxton, Derbyshire, SK17 9RZ,
United Kingdom

ATEX Notified Body for Quality Assurance

Sira Certification Service [Notified Body Number: 0518]
Unit 6, Hawarden Industrial Park,
Hawarden, CH5 3US, United Kingdom

ROSEMOUNT™

Page 3 of 3

含有China RoHS管控物质超过最大浓度限值的部件型号列表 Rosemount 3101/2/5
List of Rosemount 3101/2/5 Parts with China RoHS Concentration above MCVs

部件名称 Part Name	有害物质 / Hazardous Substances					
	铅 Lead (Pb)	汞 Mercury (Hg)	镉 Cadmium (Cd)	六价铬 Hexavalent Chromium (Cr +6)	多溴联苯 Polybrominated biphenyls (PBB)	多溴联苯醚 Polybrominated diphenyl ethers (PBDE)
电子组件 Electronics Assembly	X	O	O	O	O	O
壳体组件 Housing Assembly	O	O	O	X	O	O
传感器组件 Sensor Assembly	X	O	O	O	O	O

本表格系依据SJ/T11364的规定而制作。

This table is proposed in accordance with the provision of SJ/T11364.

O: 意为该部件的所有均质材料中该有害物质的含量均低于GB/T 26572所规定的限量要求。

O: Indicate that said hazardous substance in all of the homogeneous materials for this part is below the limit requirement of GB/T 26572.

X: 意为在该部件所使用的所有均质材料里，至少有一类均质材料中该有害物质的含量高于GB/T 26572所规定的限量要求。

X: Indicate that said hazardous substance contained in at least one of the homogeneous materials used for this part is above the limit requirement of GB/T 26572.



Global Headquarters

Emerson Automation Solutions

6021 Innovation Blvd.
Shakopee, MN 55379, USA
+1 800 999 9307 or +1 952 906 8888
+1 952 949 7001
RFQ.RMD-RCC@Emerson.com

North America Regional Office

Emerson Automation Solutions

8200 Market Blvd.
Chanhassen, MN 55317, USA
+1 800 999 9307 or +1 952 906 8888
+1 952 949 7001
RMT-NA.RCCRFQ@Emerson.com

Latin America Regional Office

Emerson Automation Solutions

1300 Concord Terrace, Suite 400
Sunrise, FL 33323, USA
+1 954 846 5030
+1 954 846 5121
RFQ.RMD-RCC@Emerson.com

Europe Regional Office

Emerson Automation Solutions

Neuhofstrasse 19a P.O. Box 1046
CH 6340 Baar
Switzerland
+41 (0) 41 768 6111
+41 (0) 41 768 6300
RFQ.RMD-RCC@Emerson.com

Asia Pacific Regional Office

Emerson Automation Solutions

1 Pandan Crescent
Singapore 128461
+65 6777 8211
+65 6777 0947
Enquiries@AP.Emerson.com

Middle East and Africa Regional Office

Emerson Automation Solutions

Emerson FZE P.O. Box 17033
Jebel Ali Free Zone - South 2
Dubai, United Arab Emirates
+971 4 8118100
+971 4 8865465
RFQ.RMTMEA@Emerson.com



[Linkedin.com/company/Emerson-Automation-Solutions](https://www.linkedin.com/company/Emerson-Automation-Solutions)



[Twitter.com/Rosemount_News](https://twitter.com/Rosemount_News)



[Facebook.com/Rosemount](https://www.facebook.com/Rosemount)



[Youtube.com/user/RosemountMeasurement](https://www.youtube.com/user/RosemountMeasurement)



[Google.com/+RosemountMeasurement](https://www.google.com/+RosemountMeasurement)

Emerson Terms and Conditions of Sale are available upon request.
The Emerson logo is a trademark and service mark of Emerson Electric Co.

Rosemount is a mark of one of the Emerson family of companies.
All other marks are the property of their respective owners.
© 2018 Emerson. All rights reserved.