

Rosemount™ 3051S Series of Instrumentation

High Pressure Solutions



Innovation reaching across your operation

With Rosemount 3051S High Pressure Solutions, operations can be optimized in these critical areas: production, quality, energy efficiency, and safety and environment. By leveraging the power of the scalable Rosemount 3051S across the entire operation, you'll be able to minimize process variability, gain greater process insight, reduce maintenance and downtime, and meet regulatory demands. What's more, it's easy to use, ensuring the full potential of the measurement investment is realized.

Rosemount 3051S SuperModule™ Platform



The most advanced pressure, flow, and level measurements

- The all-welded hermetic design delivers the industry's highest field reliability
- Patented electronics within the SuperModule
- SIL 3 capable: IEC61508 certified by an accredited third party agency for use in safety instrumented systems up to SIL 3 (minimum requirement of single use [1 oo1] for SIL2 and redundant use [1 oo2] for SIL 3)

Rosemount 3051S High Pressure Solutions



Rosemount 3051S High Static Differential Pressure Transmitter

- Coned and threaded direct connection enables operation in applications with static pressures up to 15,000 psi (1,034 bar)
- Coplanar platform enables integrated seal system solutions
- Calibrated Differential Pressure spans from 5 inH₂O to 150 psi (12,4 mbar to 10,4 bar)
- Dual-capacitance Saturn™ sensor technology corrects for overpressure and line pressure effects
- Available with Alloy C-276 process isolators

Contents

Rosemount 3051S High Static Differential Pressure Transmitter	4	Product certifications	17
Specifications	10	Dimensional drawings	22
		Options	26

Advanced functionality

WirelessHART® (IEC 62591) capabilities

Available on coplanar, in-line, and level transmitters

- Quickly deploy new pressure, level and flow measurements in 70 percent less time
- Eliminate wiring design and construction complexities to lower costs by 40 to 60 percent
- Extended range antenna capabilities provide access to remote locations
- Delivering over a decade of maintenance free performance with 15-year stability and 10-year power module life



Advanced diagnostic capabilities

- Provides diagnostic coverage from the process to the transmitter to the host
- Prevent on-scale failures by diagnosing electrical loop issues with power advisory diagnostics
- Statistical process monitoring detects abnormal process conditions enabling more productive and safer operations
- Extend diagnostic coverage to Safety Instrumented Systems (SIS) with IEC 61508 SIL 2/3 capable rating



Additional functionality

- Remote display and interface allows for direct mounting to process to eliminate impulse lines and enables access to the transmitter's interface from 100 ft. away
- Optional differential pressure + temperature measurement option available on the Rosemount 3051SHP reduces overall installation cost with a 2-in-1 DP and process temperature measurement



Rosemount 3051S High Static Differential Pressure Transmitter



Rosemount 3051S High Static Differential Pressure Transmitters bring reliability based on the industry leading Rosemount 3051S SuperModule design to installations with high static pressure conditions. The lightweight coplanar design results in a more accurate measurement while reducing transmitter weight over traditional high static pressure transmitters. Capabilities include:

- Accurate and reliable measurements up to static lines pressure of 15,000 psi (1.034 bar)
- 4–20 mA HART®, WirelessHART, FOUNDATION™ Fieldbus Protocols
- Safety certification (options code QT)
- Advanced diagnostics (option code DA2)
- Differential pressure and temperature (measurement type option code 7)

Additional information

Specifications: [page 10](#)

Certifications: [page 17](#)

Dimensional drawings: [page 22](#)

Specification and selection of product materials, options, or components must be made by the purchaser of the equipment. See [page 15](#) for more information on material selection.

Table 1. Rosemount 3051S High Static Differential Pressure Transmitter Ordering Information

The starred offerings (★) represent the most common options and should be selected for best delivery. The non-starred offerings are subject to additional delivery lead time.

Rosemount model		
3051SHP	High Static Differential Pressure Transmitter	
Performance class ⁽¹⁾		
1	Ultra: 0.055% span accuracy, 15-yr limited warranty	★
2	Classic: 0.055% span accuracy	★
Connection type		
C	Coplanar	★
Measurement type		
D	Differential pressure	★
7	Differential pressure and temperature	★
Differential pressure range		
6	–250 to 250 inH ₂ O (–623 to 623 mbar)	★
7	–700 to 700 inH ₂ O (–1,74 to 1,74 bar)	★
8	–150 to 150 psi (–10,34 to 10,34 bar)	★
Static pressure range		
A	None	★
Maximum static line pressure		
3	15,000 psi (1,034 bar)	★

Table 1. Rosemount 3051S High Static Differential Pressure Transmitter Ordering Information

The starred offerings (★) represent the most common options and should be selected for best delivery. The non-starred offerings are subject to additional delivery lead time.

Temperature input				
N	None			★
R	RTD input (type Pt 100, –328 to 1562 °F [–200 to 850 °C])			
Isolating diaphragm ⁽²⁾⁽³⁾				
3	Alloy C-276			★
Process connection				
B12 ⁽⁴⁾⁽⁵⁾	Assemble to two Rosemount 1199 Seals			★
H11	Coned and threaded, compatible with autoclave type F-250-C			
Transmitter output				
A	4–20 mA with digital signal based on HART Protocol			★
F ⁽⁶⁾	FOUNDATION Fieldbus Protocol			★
X ⁽⁷⁾	Wireless (requires wireless options and wireless Plantweb™ housing)			★
Housing style		Material	Conduit entry size	
1A	Plantweb housing	Aluminum	1/2–14 NPT	★
1B	Plantweb housing	Aluminum	M20 x 1.5	★
1C	Plantweb housing	Aluminum	G1/2	
1J	Plantweb housing	Stainless steel (SST)	1/2–14 NPT	★
1K	Plantweb housing	SST	M20 x 1.5	★
1L	Plantweb housing	SST	G1/2	
2A	Junction Box housing	Aluminum	1/2–14 NPT	★
2B	Junction Box housing	Aluminum	M20 x 1.5	★
2C	Junction Box housing	Aluminum	G1/2	
2E	Junction Box housing with output for remote display and interface	Aluminum	1/2–14 NPT	★
2F	Junction Box housing with output for remote display and interface	Aluminum	M20 x 1.5	★
2G	Junction Box housing with output for remote display and interface	Aluminum	G1/2	
2J	Junction Box housing	SST	1/2–14 NPT	★
2M	Junction Box housing with output for remote display and interface	SST	1/2–14 NPT	★
5A ⁽⁸⁾	Wireless Plantweb housing	Aluminum	1/2–14 NPT	★
5J ⁽⁸⁾	Wireless Plantweb housing	SST	1/2–14 NPT	★
7J ⁽⁸⁾	Quick connect (A size mini, 4-pin male termination)	SST	N/A	★

Table 1. Rosemount 3051S High Static Differential Pressure Transmitter Ordering Information

The starred offerings (★) represent the most common options and should be selected for best delivery. The non-starred offerings are subject to additional delivery lead time.

Wireless options (requires option code X and wireless Plantweb housing)

Update rate		
WA	User-configurable update rate	★
Operating frequency and protocol		
3	2.4 GHz DSSS, IEC 62591 (<i>WirelessHART</i> Protocol)	★
Omni-directional wireless antenna		
WK	External antenna	★
WJ	Remote antenna	
WM	Extended range, external antenna	★
WN	High-gain, remote antenna	
SmartPower™(8)		
1	Adapter for black power module (I.S. power module sold separately)	★

Other options (Include with selected model number)

Extended product warranty		
WR3	Three-year limited warranty	★
WR5	Five-year limited warranty	★
Plantweb control functionality (9)		
A01	FOUNDATION Fieldbus advanced control function block suite	★
Plantweb diagnostic functionality		
D01(9)	FOUNDATION Fieldbus diagnostics suite	★
DA2(10)(11)	Advanced HART diagnostics suite	★
RTD cable (RTD sensor must be ordered separately)		
C12	RTD Input with 12 ft. (3,66 m) of shielded cable	★
C13	RTD Input with 24 ft. (7,32 m) of shielded cable	★
C14	RTD Input with 75 ft. (22,86 m) of shielded cable	★
C22	RTD Input with 12 ft. (3,66 m) of armored shielded cable	★
C23	RTD Input with 24 ft. (7,32 m) of armored shielded cable	★
C24	RTD Input with 75 ft. (22,86 m) of armored shielded cable	★
C32	RTD Input with 12 ft. (3,66 m) of ATEX/IECEX flameproof cable	★
C33	RTD Input with 24 ft. (7,32 m) of ATEX/IECEX flameproof cable	★
C34	RTD Input with 75 ft. (22,86 m) of ATEX/IECEX flameproof cable	★
Mounting bracket		
B4	Coplanar flange bracket, all 316 SST, 2-in. pipe and panel/ bracket	★

Table 1. Rosemount 3051S High Static Differential Pressure Transmitter Ordering Information

The starred offerings (★) represent the most common options and should be selected for best delivery. The non-starred offerings are subject to additional delivery lead time.

Software configuration		
C1	Custom software configuration (requires Configuration Data Sheet)	★
Alarm level⁽¹¹⁾⁽¹²⁾		
C4	NAMUR alarm and saturation levels, high alarm	★
C5	NAMUR alarm and saturation levels, low alarm	★
C6	Custom alarm and saturation signal levels, high alarm (requires C1 and Configuration Data Sheet)	★
C7	Custom alarm and saturation signal levels, low alarm (requires C1 and Configuration Data Sheet)	★
C8	Low alarm (standard Rosemount alarm and saturation levels)	★
Hardware adjustments⁽¹¹⁾⁽¹²⁾⁽¹³⁾		
D1	Hardware adjustments (zero, span, alarm, security)	★
Ground screw⁽¹²⁾		
D4	External ground screw assembly	★
Conduit plug⁽¹⁴⁾		
DO	316 SST conduit plug	★
Customer specified bar code tag		
D6	Bar code tag	★
Product certifications⁽¹⁵⁾		
E1	ATEX Flameproof	★
E2	INMETRO Flameproof	★
E5	US Explosion-proof, Dust Ignition-proof	★
E6 ⁽¹⁶⁾	Canada Explosion-proof, Dust Ignition-proof, Division 2	★
E7	IECEx Flameproof, Dust Ignition-proof	★
EM	Technical Regulation Customs Union (EAC) Flameproof and Dust	★
I1	ATEX Intrinsic Safety	★
I5	US Intrinsically Safe; Nonincendive	★
I6	Canada Intrinsically Safe	★
I7	IECEx Intrinsic Safety	★
IA	ATEX FISCO Intrinsic Safety (FOUNDATION Fieldbus Protocol only)	★
IE	US FISCO Intrinsically Safe (FOUNDATION Fieldbus Protocol only)	★
IF	Canada FISCO Intrinsically Safe (FOUNDATION Fieldbus Protocol only)	★
IG	IECEx FISCO Intrinsic Safety (FOUNDATION Fieldbus Protocol only)	★
IM	Technical Regulation Customs Union (EAC) Intrinsic Safety	★
K1	ATEX Flameproof, Intrinsic Safety, Type n, Dust	★
K5	US Explosion-proof, Dust Ignition-proof, Intrinsically Safe, Division 2	★

Table 1. Rosemount 3051S High Static Differential Pressure Transmitter Ordering Information

The starred offerings (★) represent the most common options and should be selected for best delivery. The non-starred offerings are subject to additional delivery lead time.

K6 ⁽¹⁷⁾	Canada Explosion-proof, Dust Ignition-proof, Intrinsically Safe, Division 2	★
K7	IECEX Flameproof, Dust Ignition-proof, Intrinsic Safety, Type n	★
KA ⁽¹⁷⁾	ATEX and Canada Flameproof, Intrinsically Safe, Division 2	★
KB ⁽¹⁷⁾	US and Canada Explosion-proof, Dust Ignition-proof, Intrinsically Safe, Division 2	★
KC	US and ATEX Explosion-proof, Intrinsically Safe, Division 2	★
KD ⁽¹⁷⁾	US, Canada, and ATEX Explosion-proof, Intrinsically Safe	★
KG	US, Canada, ATEX and IECEX FISCO Intrinsic Safety	★
KM	Technical Regulations Customs Union (EAC) Flame-proof, Intrinsic Safety	★
N1	ATEX Type n	★
N7	IECEX Type n	★
ND	ATEX Dust	★
Display type⁽¹⁸⁾		
M5	Plantweb LCD display	★
M7 ⁽¹¹⁾⁽¹⁷⁾⁽¹⁹⁾	Remote mount LCD display and interface, Plantweb housing, no cable, SST bracket	★
M8 ⁽¹¹⁾⁽²⁰⁾	Remote mount LCD display and interface, Plantweb housing, 50 ft. (15 m) cable, SST bracket	★
M9 ⁽¹¹⁾⁽²⁰⁾	Remote mount LCD display and interface, Plantweb housing, 100 ft. (31 m) cable, SST bracket	★
Pressure testing		
P1	Hydrostatic testing with certificate	
Calibration certification		
Q4	Calibration certificate	★
Material traceability certification		
Q8	Material traceability certification per EN 10204 3.1B	★
Quality certification for safety		
QS ⁽¹¹⁾⁽¹³⁾	Prior-use certificate of FMEDA data	★
QT ⁽²¹⁾	Safety-certified to IEC 61508 with certificate of FMEDA data	★
Transient protection⁽²⁰⁾⁽²²⁾		
T1	Transient terminal block	★
Toolkit performance reports		
QZ	Remote seal system performance calculation report	★
NACE® certificate⁽²⁰⁾		
Q15	Certificate of compliance to NACE MR0175/ISO 15156 for wetted materials	★
Q25	Certificate of compliance to NACE MR0103 for wetted materials	★
Typical model number: 3051SHP 1CD6A3N3 H11A1A DA2 B4 M5		

1. For detailed specifications see [“Specifications” on page 10](#).
2. Materials of construction comply with metallurgical requirements highlighted within NACE MR0175/ISO 15156 for sour oil field production environments. Environmental limits apply to certain materials. Consult latest standard for details. Selected materials also conform to NACE MR0103 for sour refining environments. Order with Q15 or Q25 to receive a NACE certificate.
3. Isolator diaphragm selection will dictate materials of construction for wetted parts.
4. Consult factory for available Rosemount 1199 high pressure remote seal options.
5. “Assemble to” items are specified separately and require a completed model number.
6. Requires Plantweb housing.
7. Only intrinsically safe approval codes apply.
8. Long-life power module must be shipped separately, order power module 701PBKKF.
9. Only available with output code F.
10. Only available with output code A.
11. Requires Plantweb housing and output code A. Includes hardware adjustments as standard.
12. This assembly is included with approval options EP, KP, E1, N1, K1, ND, E4, E7, N7, K7, E2, E3, KA, KC, KD, IA, IB, IE, IF, IG, KG, K2, N3, EM, and KM. It is also included with transient protection T1.
13. Not available with housing style codes 00, 01, 2E, 2F, 2G, 2M, 5A, 5J, or 7J.
14. Transmitter is shipped with 316 SST conduit plug (uninstalled) in place of standard carbon steel conduit plug.
15. Valid when SuperModule platform and housing have equivalent approvals.
16. Not available with M20 or G 1/2 conduit entry size.
17. Not available with output code F, option code DA2, or option code QT.
18. Not available with Housing code 7J.
19. See the Rosemount 3051S [Reference Manual](#) for cable requirements. Contact an Emerson™ representative for additional information.
20. NACE compliant wetted materials are identified by [Footnote 2](#).
21. Not available with output code F or X. Not available with housing code 7J.
22. Not available with housing code 00, 5A, 5J, or 7J.

Specifications

Performance specifications

Rosemount 3051SHP

For zero-based spans, reference conditions, silicone oil fill, C-276 isolating diaphragm, coned and threaded process connections, digital trim values set to equal range points.

Conformance to specification ($\pm 3\sigma$ [sigma])

Technology leadership, advanced manufacturing techniques, and statistical process control ensure pressure measurement specification conformance to $\pm 3\sigma$ or better.

Reference accuracy

Stated reference accuracy equations include terminal based linearity, hysteresis, and repeatability. For FOUNDATION Fieldbus and wireless devices, use calibrated range in place of span.

Table 2. Rosemount 3051SHP Differential Pressure Transmitter⁽¹⁾

Differential pressure range	Reference accuracy
6	$\pm 0.055\%$ of span; spans less than 10:1, $\pm [0.005 + 0.01(\text{URL}/\text{span})]\%$ of span
7	$\pm 0.055\%$ of span; spans less than 10:1, $\pm [0.015 + 0.005(\text{URL}/\text{span})]\%$ of span
8	$\pm 0.055\%$ of span; spans less than 5:1, $\pm [0.015 + 0.005(\text{URL}/\text{span})]\%$ of span

1. For transmitters assembled to Rosemount 1199 remote seals, consult factory.

Process temperature RTD

$\pm 0.67^\circ\text{F}$ (0.37°C)

Long term stability

Table 3. Rosemount 3051SHP Differential Pressure Transmitter

Differential pressure range	Stability
Range 6 to 8	$\pm 0.35\%$ of URL for 10 years

Process temperature

The greater of $\pm 0.185^\circ\text{F}$ (0.103°C) or 0.1 percent of reading per year (excludes RTD sensor stability)

Warranty⁽¹⁾

Classic models

- One-year limited warranty is standard⁽²⁾
- Extended three-year and five-year limited warranties available if ordered⁽³⁾

Ultra models

15-year limited warranty⁽⁴⁾

1. Warranty details can be found in Emerson Terms & Condition of Sale. Document 63445. Rev G (10/06).
2. Goods are warranted for 12 months from the date of initial installation of 18 months from the date of shipment by seller, whichever period expires first.
3. Three-year and five-year warranty apply to date of shipment by seller.
4. Rosemount Ultra transmitters have a limited warranty of 15 years from date of shipment. All other provisions of Emerson standard limited warranty remain the same.

Dynamic performance

Total response time ⁽¹⁾⁽²⁾	100 ms
Dead time ⁽³⁾	45 ms
Sensor update rate ⁽⁴⁾	22 Hz

1. For transmitters assembled to 1199 remote seals, consult factory.
2. For FOUNDATION Fieldbus (output code F), add 52 ms to stated values (not including segment macro-cycle). For option code DA2, add 45 ms (nominal) to stated values.
3. For option code DA2, dead time is 90 milliseconds (nominal).
4. Does not apply to Wireless (output code X). See "IEC 62591 (WirelessHART)" on page 13 for wireless update rate.

Ambient temperature effect

Table 4. Rosemount 3051SHP Differential Pressure Transmitter

Differential pressure range	Ambient temperature effect ⁽¹⁾
6	$\pm 0.035\%$ URL + 0.0625% span from 1:1 to 5:1; $\pm 0.070\%$ + 0.125% span from >5:1 to 50:1
7	$\pm 0.0125\%$ URL + 0.0625% span from 1:1 to 5:1; $\pm 0.025\%$ + 0.125% span from >5:1 to 100:1
8	$\pm 0.0125\%$ URL + 0.0625% span from 1:1 to 5:1; $\pm 0.025\%$ + 0.125% span from >5:1 to 150:1

1. Temperature effect calculated per 50 °F (28 °C).

Process temperature RTD interface

Minimum span = 0.39°F (0.216°C) per 50 °F (28 °C)

Rosemount 3051SHP line pressure effect (DP measurement only)

Differential pressure range	Zero error	Span error
6	±0.1% URL per 1000 psi	±0.3% of reading per 1000 psi
7		±0.2% of reading per 1000 psi
8		-1.6% ±0.2% of reading per 1000 psi

Mounting position effects

Rosemount 3051SHP Differential Pressure Transmitter

Zero shifts to ±1.25 in H₂O (6.22 mbar), which can be zeroed.
Span: No effect

Vibration effect

Less than ±0.1% of URL when tested per the requirements of IEC60770-1 field or pipeline with high vibration level (10 to 60 Hz 0.21 mm displacement peak amplitude/60 to 2000 Hz 3g).

For housing style codes 1J, 1K, 1L, 2J, and 2M: Less than ±0.1% of URL when tested per the requirements of IEC60770-1 field with general application or pipeline with low vibration level (10 to 60 Hz 0.15 mm displacement peak amplitude/60 to 500 Hz 2g).

Power supply effect

Less than ±0.005% of calibrated span per volt change in voltage at the transmitter terminals

Electromagnetic compatibility (EMC)

Meets all industrial environment requirements of EN61326 and NAMUR NE-21⁽¹⁾⁽²⁾. Maximum deviation < 1percent span during EMC disturbance⁽³⁾⁽⁴⁾⁽⁵⁾.

- NAMUR NE-21 is met on output type A if no external temperature sensor is attached.
- NAMUR NE-21 does not apply to wireless output code X.
- During surge event device may exceed maximum EMC deviation limit or reset; however, device will self-recover and return to normal operation within specified start-up time.
- For devices with junction box housing or remote display (housing styles: 2A-2C, 2E-2G, 2J, 2M) testing performed with shielded cable.
- Measurement type 7 requires shielded cable for the process temperature connection.

Transient protection (option T1)

Tested in accordance with IEEE C62.41.2-2002, Location category B

- 6 kV crest (0.5 μs – 100 kHz)
- 3 kA crest (8 x 20 microseconds)
- 6 kV crest (1.2 x 50 microseconds)

Functional specifications

Range and sensor limits

Table 5. Rosemount 3051SHP Differential Pressure Transmitter

Differential pressure range	LRL	URL
6	-250 inH ₂ O (-623 mbar)	250 inH ₂ O (623 mbar)
7	-700 inH ₂ O (-1,74 bar)	700 inH ₂ O (1,74 bar)
8	-150 psi (-10,34 bar)	150 psi (10,34 bar)

Process temperature RTD interface

LRL	URL
-328 °F (-200 °C)	1562 °F (850 °C)

Minimum span limits

Table 6. Rosemount 3051SHP Differential Pressure Transmitter⁽¹⁾

Differential pressure range	Limit
6	5 inH ₂ O (12,44 mbar)
7	7 inH ₂ O (17,42 mbar)
8	1 psi (68,95 mbar)

1. For transmitters assembled to Rosemount 1199 remote seals, consult factory.

Process temperature RTD interface

52 °F (11 °C)

Service

Rosemount 3051SHP (DP only)

Liquid, gas, and vapor applications

Rosemount 3051SHP (DP + temperature)

Liquids, saturated steam

4–20 mA HART

Zero and span adjustment

Zero and span values can be set anywhere within the range. Span must be greater than or equal to the minimum span.

Output

Two-wire 4–20 mA is user-selectable for linear or square root output. Digital process variable superimposed on 4–20 mA signal, available to any host that conforms to the HART Protocol.

Power supply

External power supply required.

- Rosemount 3051S: 10.5 to 42.4 Vdc with no load
- Rosemount 3051S with Advanced HART Diagnostics Suite: 12 to 42.4 Vdc with no load

Load limitations

Maximum loop resistance is determined by the voltage level of the external power supply, as described by:

Figure 1. Rosemount 3051SHP

Maximum loop resistance = 43.5 x (power supply voltage – 10.5)

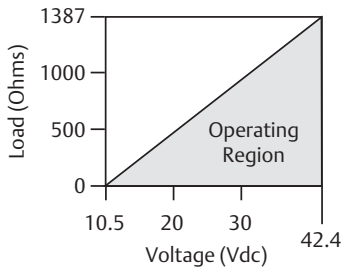

The Field Communicator requires a minimum loop resistance of 250Ω for communication.

Table 7. Rosemount 3051SHP, 3051SHP with HART Diagnostics (option code DA2), and 3051SHP with DP + T measurement

Maximum Loop Resistance = 43.5 x (power supply voltage – 12.0)

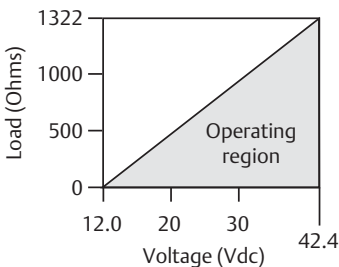

The Field Communicator requires a minimum loop resistance of 250Ω for communication.

Advanced HART diagnostics suite (option code DA2)

Statistical process monitoring (SPM) provides statistical data (standard deviation, mean, coefficient of variation) that can be used to detect process and process equipment anomalies, including plugged impulse lines, air entrainment, pump cavitation, furnace flame instability, distillation column flooding and more. This diagnostic allows you to take preventative measures before abnormal process situations result in unscheduled downtime or rework.

Power advisory diagnostic pro-actively detects and notifies you of degraded electrical loop integrity before it can affect your process operation. Example loop problems that can be detected include water in the terminal compartment, corrosion of terminals, improper grounding, and unstable power supplies.

The device dashboard presents the diagnostics in a graphical, task-based interface that provides single click access to critical process/device information and descriptive graphical troubleshooting.

Suite includes: SPM, power advisory, status log, variable log, advanced process alerts, service alerts, and time stamp capability.

FOUNDATION Fieldbus

Power supply

External power supply required; transmitters operate on 9.0 to 32.0 Vdc transmitter terminal voltage.

Current draw

17.5 mA for all configurations (including LCD display option)

FOUNDATION Fieldbus parameters

Schedule entries	14 (max.)
Links	30 (max.)
Virtual communications relationships (VCR)	20 (max.)

Standard function blocks

Resource block

Contains hardware, electronics, and diagnostic information.

Transducer block

Contains actual sensor measurement data including the sensor diagnostics and the ability to trim the pressure sensor or recall factory defaults.

LCD display block

Configures the local display.

Two analog input blocks

Processes the measurements for input into other function blocks. The output value is in engineering or custom units and contains a status indicating measurement quality.

PID block with auto-tune

Contains all logic to perform PID control in the field including cascade and feed forward. Auto-tune capability allows for superior tuning for optimized control performance.

Backup link active scheduler (LAS)

The transmitter can function as a link active scheduler if the current link master device fails or is removed from the segment.

Software upgrade in the Field

Software for the Rosemount 3051S with FOUNDATION Fieldbus is easy to upgrade in the field using the FOUNDATION Fieldbus “Common Device Software Download” procedure.

Plantweb alerts

Enable the full power of the Plantweb digital architecture by diagnosing instrumentation issues, communicating advisory, maintenance, and failure details, and recommending a solution.

Advanced control function block suite (option code A01)

Input selector block

Selects between inputs and generates an output using specific selection strategies such as minimum, maximum, midpoint, average, or first “good”.

Arithmetic block

Provides pre-defined application-based equations including flow with partial density compensation, electronic remote sensors, hydrostatic tank gauging, ratio control and others.

Signal characterizer block

Characterizes or approximates any function that defines an input/output relationship by configuring up to twenty X, Y coordinates. The block interpolates an output value for a given input value using the curve defined by the configured coordinates.

Integrator block

Compares the integrated or accumulated value from one or two variables to pre-trip and trip limits and generates discrete output signals when the limits are reached. This block is useful for calculating total flow, total mass, or volume over time.

Output splitter block

Splits the output of one PID or other control block so that the PID will control two valves or other actuators.

Control selector block

Selects one of up to three inputs (highest, middle, or lowest) that are normally connected to the outputs of PID or other control function blocks.

Block	Execution time
Resource	N/A
Transducer	N/A
LCD Display Block	N/A
Analog Input 1, 2	20 milliseconds
PID with Auto-tune	35 milliseconds
Input Selector	20 milliseconds
Arithmetic	20 milliseconds
Signal Characterizer	20 milliseconds
Integrator	20 milliseconds
Output Splitter	20 milliseconds
Control Selector	20 milliseconds

Fully compensated mass flow block (option code H01)

Calculates fully compensated mass flow based on differential pressure with external process pressure and temperature measurements over the Fieldbus segment. Configuration for the mass flow calculation is easily accomplished using the Rosemount Engineering Assistant 5.5.1 software.

FOUNDATION Fieldbus diagnostics suite (option code D01)

SPM provides statistical data (standard deviation and mean) that can be used to detect process and process equipment anomalies, including plugged impulse lines, air entrainment, pump cavitation, furnace flame instability, distillation column flooding, and more. This diagnostic allows you to take preventative measures before abnormal process situations result in unscheduled downtime or rework.

The device dashboard presents the diagnostics in a graphical, task-based interface that provides single click access to critical process/device information and descriptive graphical troubleshooting.

Suite includes: SPM and plugged impulse line detection (PIL).

IEC 62591 (WirelessHART)

Output

IEC 62591 (WirelessHART), 2.4 GHz DSSS

Radio frequency power output from antenna

- External antenna (WK option):
Maximum of 10 mW (10 dBm) EIRP
- Extended range, external antenna (WM option):
Maximum of 18 mW (12.5 dBm) EIRP
- Remote (WJ option) antenna:
Maximum of 17 mW (12.3 dBm) EIRP
- High-gain, remote antenna (WN option):
Maximum of 40 mW (16 dBm) EIRP

Local display

The optional seven-digit LCD display can display user-selectable information such as primary variable in engineering units, percent of range, sensor module temperature, and electronics temperature. The display updates based on the wireless update rate.

Update rate

User-selectable 1 second to 60 minutes

Power module

Field replaceable, keyed connection eliminates the risk of incorrect installation, Intrinsically Safe Lithium-thionyl chloride Power Module with polybutadine terephthalate (PBT) enclosure. Ten-year life at one minute update rate.⁽¹⁾

1. Reference conditions are 70 °F (21 °C), and routing data for three additional network devices.

Note

Continuous exposure to ambient temperature limits of -40 or 185 °F (-40 or 85 °C) may reduce specified life by less than 20 percent.

Overpressure limits

Pressure range	Overpressure limit
Rosemount 3051SHP, Static	22,500 psi (1,551 bar)
Rosemount 3051SHP, DP	15,000 psi (1,034 bar)

Maximum working pressure limits

Maximum working pressure is the maximum pressure allowed for normal transmitter operation. For a differential pressure transmitter, the maximum working pressure is the static line pressure under which the transmitter can safely operate. If one side of the transmitter is exposed to the full static line pressure due to mis-valving, the transmitter will experience an output shift and must be re-zeroed. For a gage or absolute pressure transmitter, the maximum working pressure is the same as the Upper Range Limit (URL). The maximum working pressure of transmitters with assemble-to options is limited by the lowest maximum pressure rating of the individual components.

Rosemount 3051SHP

The maximum working pressure of the Rosemount 3051SHP is specified in the model number of the product and is rated up to 15,000 psi (1,034 bar).

Static pressure limits for the 3051SHP

Operates within specifications between static line pressures of: 0,5 psia to 15,000 psig (0,03 to 1.034,21 bar) for transmitters with a maximum working pressure of 15,000 psig.

Burst pressure limits

Rosemount 3051SHP: 37,500 psi (2,585 bar)

Temperature limits

Ambient

-40 to 185 °F (-40 to 85 °C)
with LCD display⁽¹⁾: -40 to 175 °F (-40 to 80 °C)

1. LCD display may not be readable and LCD display updates will be slower at temperatures below -4 °F (-20 °C).

Storage

-50 to 185 °F (-46 to 85 °C)
with LCD display: -40 to 185 °F (-40 to 85 °C)
with wireless output: -40 to 185 °F (-40 to 85 °C)

Process temperature limits

At atmospheric pressures and above:

Coplanar sensor module	
Silicone fill sensor ⁽¹⁾	-40 to 250 °F (-40 to 121 °C)

1. Process temperatures above 185 °F (85 °C) require derating the ambient limits by a 1.5:1 ratio. For example, for process temperature of 195 °F (91 °C), new ambient temperature limit is equal to 170 °F (77 °C). This can be determined as follows: (195 - 185 °F) x 1.5 = 15 °F, 185 - 15 °F = 170 °F

Indication

Optional three-line LCD display

Zero and span adjustment requirements

Zero and span values can be set anywhere within the range limits stated in Table 5 on page 11. Span must be greater than or equal to the minimum span stated in Table 6 on page 11.

Humidity limits

0 to 100% relative humidity

Turn-on time⁽¹⁾

When power is applied to the transmitter during startup, performance will be within specification per the time period described below:

- Rosemount 3051S_T: 2 seconds
- Rosemount 3051SHP DP: 2 seconds
- Rosemount 3051SHP DP + T: 5 seconds

1. Does not apply to wireless option code X.

Volumetric displacement

Less than 0.0005 in³ (0,008 cm³)

Damping

Analog output response time to a step change is user-selectable from 0 to 60 seconds for one time constant. Software damping is in addition to sensor module response time.

For Rosemount 3051SHP DP + T, each variable can be individually adjusted.

Transmitter security

Activating the transmitter security function prevents changes to the transmitter configuration, including local zero and span adjustments. Security is activated by an internal switch.

Failure mode alarm

4–20 mA HART (output option code A)

If self-diagnostics detect a gross transmitter failure, the analog signal will be driven off-scale to alert the user. Rosemount standard (default), NAMUR, and custom alarm levels are available (see [Alarm configuration](#)).

High or low alarm signal is software-selectable or hardware-selectable via the optional switch (option D1).

Alarm configuration

	High alarm	Low alarm
Default	≥ 21.75 mA	≤ 3.75 mA
NAMUR ⁽¹⁾	≥ 22.5 mA	≤ 3.6 mA
Custom levels ⁽²⁾⁽³⁾	20.2–23.0 mA	3.4–3.8 mA

1. Analog output levels are compliant with NAMUR recommendation NE 43, see option codes C4 or C5.
2. Low alarm must be 0.1 mA less than low saturation and high alarm must be 0.1 mA greater than high saturation.
3. For option code DA2, low alarm custom values are 3.6 to 3.8 mA.

Safety-certified transmitter failure values⁽¹⁾

Device safety accuracy: ±2.0% of analog output span ⁽²⁾
 Device safety response time: 1.5 seconds

1. Does not apply to wireless option code X.
2. Trip values in the DCS or safety logic solver should be derated by this device safety accuracy.

Physical specifications

Material selection

Emerson provides a variety of Rosemount product with various product options and configurations including materials of construction that can be expected to perform well in a wide range of applications. The Rosemount product information presented is intended as a guide for the purchaser to make an appropriate selection for the application. It is the purchaser's sole responsibility to make a careful analysis of all process parameters (such as all chemical components, temperature, pressure, flow rate, abrasives, contaminants, etc.), when specifying product, materials, options and components for the particular application. Emerson is not in a position to evaluate or guarantee the compatibility of the process fluid or other process parameters with the product, options, configuration or materials of construction selected.

Electrical connections

1/2–14 NPT, G1/2, and M20 x 1 1/2 conduit. HART interface connections fixed to terminal block for output code A and X.

Process connections

Rosemount 3051SHP

Autoclave connection or seals

Process-wetted parts

Process isolating diaphragms

Coplanar sensor module

Alloy C-276 (UNS N10276)

Non-wetted parts

Electronics housing

Low-copper aluminum alloy or CF-8M (cast 316 SST)

Enclosures meet NEMA® Type 4X, IP66, and IP68 [66 ft. (20 m) for 168 hours] when properly installed.

Note

IP 68 is not available with wireless output.

Coplanar sensor module housing

Rosemount 3051SHP

C-276 module base, 316L SST upper module housing

Sensor module fill fluid

Silicone is standard.

Paint for aluminum housing

Polyurethane

Cover O-rings

Buna-N

Wireless antenna

External antenna (WK/WM)

PBT/PC integrated omni-directional antenna

Remote antenna (WN)

Fiberglass omni-directional antenna

Power module

Field replaceable, keyed connection eliminates the risk of incorrect installation, Intrinsically Safe Lithium-thionyl chloride power module with PBT enclosure

Shipping weights

Sensor module weights

Rosemount 3051SHP sensor module

4.49 lb (2,04 kg)

Transmitter weights⁽¹⁾

Rosemount 3051SHP Transmitter with sensor module	
Junction box housing, direct process connection	5.64 lb (2,56 kg)
Plantweb housing, direct process connection	6.04 lb (2,74 kg)
Wireless Plantweb housing, direct process connection	6.64 lb (3,01 kg)

1. Fully functional transmitter with sensor module, housing, terminal block, and covers. Does not include LCD display.

Transmitter option weights

Option code	Option	Add lb (kg)
1J, 1K, 1L	SST Plantweb housing	3.5 (1,6)
2J	SST Junction Box housing	3.4 (1,5)
7J	SST Quick Connect	0.4 (0,2)
2A, 2B, 2C	Aluminum Junction Box housing	1.1 (0,5)
1A, 1B, 1C	Aluminum Plantweb housing	1.1 (0,5)
M5 ⁽¹⁾	LCD display for Aluminum Plantweb housing	0.8 (0,4)
	LCD display for SST Plantweb housing	1.6 (0,7)
B4	SST mounting bracket for coplanar flange	1.2 (0,5)

1. Includes LCD display and display cover.

Transmitter component weights

Item	Weight in lb (kg)
Aluminum standard cover	0.4 (0,2)
SST standard cover	1.3 (0,6)
Aluminum display cover	0.7 (0,3)
SST display cover	1.5 (0,7)
Wireless extended cover	0.7 (0,3)
LCD display ⁽¹⁾	0.1 (0,04)
Junction box terminal block	0.2 (0,1)
Plantweb terminal block	0.2 (0,1)
Power module	0.5 (0,2)

1. Display only.

Product certifications

Rev 2.6

Ordinary Location Certification

As standard, the transmitter has been examined and tested to determine that the design meets the basic electrical, mechanical, and fire protection requirements by a nationally recognized test laboratory (NRTL) as accredited by the Federal Occupational Safety and Health Administration (OSHA)

European Directive Information

A copy of the EU Declaration of Conformity can be found at the end of the Quick Start Guide. The most recent revision of the EU Declaration of Conformity can be found at Emerson.com/Rosemount.

Installing Equipment in North America

The US National Electrical Code® (NEC) and the Canadian Electrical Code (CEC) permit the use of Division marked equipment in Zones and Zone marked equipment in Divisions. The markings must be suitable for the area classification, gas, and temperature class. This information is clearly defined in the respective codes.

USA

- E5** US Explosionproof, Dust Ignition-proof
Certificate: 1143113
Standards: FM Class 3600 - 2011, FM Class 3615 - 2006, FM Class 3810 - 2005, UL 1203 5th Ed., UL 50E 1st Ed., UL 61010-1 (3rd edition)
Markings: XP CL I, DIV 1, GP B, C, D; T5; DIP CL II, DIV 1, GP E, F, G; CL III; $-50\text{ °C} \leq T_a \leq +85\text{ °C}$; Seal Not Required; Type 4X
- I5** US Intrinsically Safe; Nonincendive
Certificate: 1143113
Standards: FM Class 3600 - 2011, FM Class 3610 - 2010, FM Class 3611 - 2004, FM Class 3810 - 2005, UL 50E 1st Ed., UL 61010-1 (3rd edition)
Markings: IS CL I,II,III, DIV 1, GP A, B, C, D, E, F, G, T4; Class 1, Zone 0 AEx ia IIC T4($-50\text{ °C} \leq T_a \leq +70\text{ °C}$) [HART]; T4($-50\text{ °C} \leq T_a \leq +60\text{ °C}$) [Fieldbus]; NI CL 1, DIV 2, GP A, B, C, D, T5, $T_a = 70\text{ °C}$; Rosemount drawing 03251-1006; Type 4X
- IE** US FISCO Intrinsically Safe
Certificate: 1143113
Standards: FM Class 3600 - 2011, FM Class 3610 - 2010, FM Class 3810 - 2005, UL 50E 1st Ed., UL 61010-1 (3rd edition)

Markings: IS CL I, DIV 1, GP A, B, C, D, T4($-50\text{ °C} \leq T_a \leq +60\text{ °C}$); Class 1, Zone 0 AEx ia IIC T4; Rosemount drawing 03251-1006; Type 4X

Canada

- E6** Canada Explosion-proof, Dust Ignition-proof, Division 2
Certificate: 1143113
Standards: CAN/CSA C22.2 No. 0-10, CSA C22.2 No. 25-1966 (R2014), CSA C22.2 No. 30-M1986 (R2012), CSA C22.2 No. 94.2-07, CSA C22.2 No. 213-M1987 (R2013), CAN/CSA-C22.2 No. 61010-1-12, ANSI/ISA 12.27.01-2011
Markings: Class I, Groups B, C, D, $-50\text{ °C} \leq T_a \leq +85\text{ °C}$; Class II, Groups E, F, G; Class III; suitable for Class I, Zone 1, Group IIB+H2, T5; Class I, Division 2, Groups A, B, C, D; suitable for Class I, Zone 2, Group IIC, T5; Seal Not Required; Dual Seal; Type 4X
- I6** Canada Intrinsically Safe
Certificate: 1143113
Standards: CAN/CSA C22.2 No. 0-10, CAN/CSA-60079-0-11, CAN/CSA C22.2 No. 60079-11:14, CSA C22.2 No. 94.2-07, ANSI/ISA 12.27.01-2011
Markings: Intrinsically Safe Class I, Division 1; Groups A, B, C, D; suitable for Class 1, Zone 0, IIC, T3C, $T_a = 70\text{ °C}$; Rosemount drawing 03251-1006; Dual Seal; Type 4X
- IF** Canada FISCO Intrinsically Safe
Certificate: 1143113
Standards: CAN/CSA C22.2 No. 0-10, CAN/CSA-60079-0-11, CAN/CSA C22.2 No. 60079-11:14, CSA C22.2 No. 94.2-07, ANSI/ISA 12.27.01-2011
Markings: Intrinsically Safe Class I, Division 1; Groups A, B, C, D; suitable for Class 1, Zone 0, IIC, T3C, $T_a = 70\text{ °C}$; Rosemount drawing 03251-1006; Dual Seal; Type 4X

Europe

E1 ATEX Flameproof

Certificate: DEKRA 15ATEX0108X

Standards: EN 60079-0:2012 + A11:2013, EN60079-1:2014, EN60079-26:2015

Markings: II 1/2 G Ex db IIC T6...T4 Ga/Gb, T6(-60 °C ≤ T_a ≤ +70 °C), T4/T5 (-60 °C ≤ T_a ≤ +80 °C); V_{max} = 42.4 VDC

Temperature class	Process temperature	Ambient temperature
T6	-60 °C to +70 °C	-60 °C to +70 °C
T5	-60 °C to +80 °C	-60 °C to +80 °C
T4	-60 °C to +120 °C	-60 °C to +80 °C

Special Conditions for Safe Use (X):

1. This device contains a thin wall diaphragm less than 1 mm thickness that forms a boundary between zone 0 (process connection) and zone 1 (all other parts of the equipment). The model code and data sheet are to be consulted for details of the diaphragm material. Installation, maintenance and use shall take into account the environmental conditions to which the diaphragm will be subjected. The manufacturer's instructions for installation and maintenance shall be followed in detail to assure safety during its expected lifetime.
2. Flameproof joints are not intended for repair.
3. Non-standard paint options may cause risk from electrostatic discharge. Avoid installations that could cause electrostatic build-up on painted surfaces, and only clean the painted surfaces with a damp cloth. If paint is ordered through a special option code, contact the manufacturer for more information.
4. Appropriate cable, glands and plugs need to be suitable for a temperature of 5 °C greater than maximum specified temperature for location where installed.

I1 ATEX Intrinsic Safety

Certificate: BAS01ATEX1303X

Standards: EN 60079-0: 2012, EN 60079-11: 2012

Markings: II 1 G Ex ia IIC T4 Ga, T4(-60 °C ≤ T_a ≤ +70 °C)

Model	U _i	I _i	P _i	C _i	L _i
SuperModule	30 V	300 mA	1.0 W	30 nF	0
3051S...A; 3051SF...A; 3051SAL...C; 3051SHP...D...A	30 V	300 mA	1.0 W	12 nF	0
3051S...F; 3051SF...F; 3051SHP...D...F	30 V	300 mA	1.3 W	0	0
3051S...F...IA; 3051SF...F...IA; 3051SHP...D...F...IA	17.5 V	380 mA	5.32 W	0	0

3051S ...A...M7, M8, or M9; 3051SF ...A...M7, M8, or M9; 3051SAL...C... M7, M8, or M9; 3051SHP...D... M7, M8, or M9	30 V	300 mA	1.0 W	12 nF	60 μH
3051SAL; 3051SAM	30 V	300 mA	1.0 W	12 nF	33 μH
3051SAL...M7, M8, or M9 3051SAM...M7, M8, or M9	30 V	300 mA	1.0 W	12 nF	93 μH
RTD option for 3051SF	5 V	500 mA	0.63 W	N/A	N/A
3051SHP...7...A	30 V	300 mA	1.0 W	14.8 nF	0
RTD option for 3051SHP...7...A	30 V	2.31 mA	17.32 mW	N/A	N/A
3051SHP...7...F	30 V	300 mA	1.3 W	0	0
3051SHP...7...F...IA	17.5 V	380 mA	5.32 W	0	0
RTD option for 3051SHP...7...F	30 V	18.24 mA	137 mW	0.8 nF	1.33 mH

Special Conditions for Safe Use (X):

1. The Rosemount 3051S Transmitters fitted with transient protection are not capable of withstanding the 500 V test as defined in Clause 6.3.13 of EN 60079-11:2012. This must be taken into account during installation.
2. The terminal pins of the Rosemount 3051S SuperModule must be provided with a degree of protection of at least IP20 in accordance with IEC/EN 60529.
3. The Rosemount 3051S enclosure may be made of aluminum alloy and given a protective polyurethane paint finish; however, care should be taken to protect it from impact or abrasion if located in a zone 0 area.

IA ATEX FISCO

Certificate: BAS01ATEX1303X

Standards: EN 60079-0:2012, EN 60079-11:2012

Markings: II 1 G Ex ia IIC T4 Ga, T4(-60 °C ≤ T_a ≤ +70 °C)

Parameter	FISCO
Voltage U _i	17.5 V
Current I _i	380 mA
Power P _i	5.32 W
Capacitance C _i	0
Inductance L _i	0

Special Conditions for Safe Use (X):

1. The Rosemount 3051S Transmitters fitted with transient protection are not capable of withstanding the 500 V test as defined in Clause 6.3.13 of EN 60079-11:2012. This must be taken into account during installation.
2. The terminal pins of the Rosemount 3051S SuperModule must be provided with a degree of protection of at least IP20 in accordance with IEC/EN 60529.
3. The Rosemount 3051S enclosure may be made of aluminum alloy and given a protective polyurethane paint finish; however, care should be taken to protect it from impact or abrasion if located in a zone 0 area.

ND ATEX Dust

Certificate: BAS01ATEX1374X

Standards: EN 60079-0:2012, EN 60079-31:2009

Markings:  II 1 D Ex ta IIC T105 °C T₅₀₀ 95 °C Da, (-20 °C ≤ T_a ≤ +85 °C), V_{max} = 42.4 V

Special Conditions for Safe Use (X):

1. Cable entries must be used which maintain the ingress protection of the enclosure to at least IP66.
2. Unused cable entries must be filled with suitable blanking plugs which maintain the ingress protection of the enclosure to at least IP66.
3. Cable entries and blanking plugs must be suitable for the ambient temperature range of the apparatus and capable of withstanding a 7 J impact test.
4. The SuperModule(s) must be securely screwed in place to maintain the ingress protection of the enclosure(s).

N1 ATEX Type n

Certificate: BAS01ATEX3304X

Standards: EN 60079-0:2012, EN 60079-15:2010

Markings:  II 3 G Ex nA IIC T5 Gc, (-40 °C ≤ T_a ≤ +85 °C), V_{max} = 45 V

Special Condition for Safe Use (X):

1. The equipment is not capable of withstanding the 500 V insulation test required by clause 6.5 of EN 60079-15:2010. This must be taken into account when installing the equipment.

Note

RTD Assembly is not included with the Rosemount 3051SFx Type n Approval.

International

E7 IECEx Flameproof and Dust

Certificate: IECEx DEK 15.0072X, IECEx BAS 09.0014X

Standards: IEC 60079-0:2011, IEC 60079-1:2014, IEC 60079-26:2014, IEC 60079-31:2008

Markings: Ex db IIC T6...T4 Ga/Gb, T6 (-60 °C ≤ T_a ≤ +70 °C), T4/T5 (-60 °C ≤ T_a ≤ +80 °C); V_{max} = 42.4 VDC
Ex ta IIC T105 °C T₅₀₀ 95 °C Da (-20 °C ≤ T_a ≤ +85 °C)

Temperature class	Process temperature	Ambient temperature
T6	-60 °C to +70 °C	-60 °C to +70 °C
T5	-60 °C to +80 °C	-60 °C to +80 °C
T4	-60 °C to +120 °C	-60 °C to +80 °C

Special Conditions for Safe Use (X):

1. This device contains a thin wall diaphragm less than 1 mm thickness that forms a boundary between zone 0 (process connection) and zone 1 (all other parts of the equipment). The model code and data sheet are to be consulted for details of the diaphragm material. Installation, maintenance and use shall take into account the environmental conditions to which the diaphragm will be subjected. The manufacturer’s instructions for installation and maintenance shall be followed in detail to assure safety during its expected lifetime.
2. Flameproof joints are not intended for repair.
3. Non-standard paint options may cause risk from electrostatic discharge. Avoid installations that could cause electrostatic build-up on painted surfaces, and only clean the painted surfaces with a damp cloth. If paint is ordered through a special option code, contact the manufacturer for more information.
4. Appropriate cable, glands and plugs need to be suitable for a temperature of 5 °C greater than maximum specified temperature for location where installed.
5. Cable entries must be used which maintain the ingress protection of the enclosure to at least IP66.
6. Unused cable entries must be filled with suitable blanking plugs which maintain the ingress protection of the enclosure to at least IP66.
7. Cable entries and blanking plugs must be suitable for the ambient temperature range of the apparatus and capable of withstanding a 7 J impact test.
8. The Rosemount 3051S SuperModule must be securely screwed in place to maintain the ingress protection of the enclosure.

I7 IECEx Intrinsic Safety

Certificate: IECEx BAS 04.0017X

Standards: IEC 60079-0:2011, IEC 60079-11:2011

Markings: Ex ia IIC T4 Ga, T4(-60 °C ≤ T_a ≤ +70 °C)

Model	U _i	I _i	P _i	C _i	L _i
SuperModule™	30 V	300 mA	1.0 W	30 nF	0
3051S...A; 3051SF...A; 3051SAL...C; 3051SHP...D...A	30 V	300 mA	1.0 W	12 nF	0
3051S...F; 3051SF...F; 3051SHP...D...F	30 V	300 mA	1.3 W	0	0
3051S...F...IA; 3051SF...F...IA; 3051SHP...D...F...IA	17.5V	380 mA	5.32 W	0	0
3051S ...A...M7, M8, or M9; 3051SF ...A...M7, M8, or M9; 3051SAL...C...M7, M8, or M9; 3051SHP...D...M7, M8, or M9	30 V	300 mA	1.0 W	12 nF	60 μH
3051SAL; 3051SAM	30 V	300 mA	1.0 W	12 nF	33 μH
3051SAL...M7, M8, or M9 3051SAM...M7, M8, or M9	30 V	300 mA	1.0 W	12 nF	93 μH
RTD option for 3051SF	5 V	500 mA	0.63 W	N/A	N/A
3051SHP...7...A	30 V	300 mA	1.0 W	14.8 nF	0
RTD option for 3051SHP...7...A	30 V	2.31 mA	17.32 mW	N/A	N/A
3051SHP...7...F	30 V	300 mA	1.3 W	0	0
3051SHP...7...F...IA	17.5 V	380 mA	5.32 W	0	0
RTD option for 3051SHP...7...F	30 V	18.24 mA	137 mW	0.8 nF	1.33 mH

Special Conditions for Safe Use (X):

1. The Rosemount 3051S Transmitters fitted with transient protection are not capable of withstanding the 500 V test as defined in Clause 6.3.13 of EN 60079-11:2012. This must be taken into account during installation.
2. The terminal pins of the Rosemount 3051S SuperModule must be provided with a degree of protection of at least IP20 in accordance with IEC/EN 60529.
3. The Rosemount 3051S enclosure may be made of aluminum alloy and given a protective polyurethane paint finish; however, care should be taken to protect it from impact or abrasion if located in a zone 0 area.

IG IECEx FISCO

Certificate: IECEx BAS 04.0017X

Standards: IEC 60079-0: 2011, IEC 60079-11: 2011

Markings: Ex ia IIC T4 Ga, T4(-60 °C ≤ T_a ≤ +70 °C)

Parameter	FISCO
Voltage U _i	17.5 V
Current I _i	380 mA
Power P _i	5.32 W
Capacitance C _i	0
Inductance L _i	0

Special Conditions for Safe Use (X):

1. The Rosemount 3051S Transmitters fitted with transient protection are not capable of withstanding the 500 V test as defined in Clause 6.3.13 of EN 60079-11:2012. This must be taken into account during installation.
2. The terminal pins of the Rosemount 3051S SuperModule must be provided with a degree of protection of at least IP20 in accordance with IEC/EN 60529.
3. The Rosemount 3051S enclosure may be made of aluminum alloy and given a protective polyurethane paint finish; however, care should be taken to protect it from impact or abrasion if located in a zone 0 area.

N7 IECEx Type n

Certificate: IECEx BAS 04.0018X

Standards: IEC 60079-0: 2011, IEC 60079-15: 2010

Markings: Ex nA IIC T5 Gc, (-40 °C ≤ T_a ≤ +85 °C)

Special Condition for Safe Use (X):

1. The equipment is not capable of withstanding the 500 V insulation test required by clause 6.5 of EN 60079-15:2010. This must be taken into account when installing the equipment.

Brazil

E2 Brazil Flameproof

Certificate: UL-BR 16.0855X

Standards: ABNT NBR IEC 60079-0:2008+Errata 1:2011, ABNT NBR IEC 60079-1:2009+Errata 1:2011, ABNT NBR IEC 60079-26:2008+Errata 1:2008

Markings: Ex db IIC T6...T4 Ga/Gb, T6(-60 °C ≤ T_a ≤ +70 °C), T4/T5(-60 °C ≤ T_a ≤ +80 °C)

Special Conditions for Safe Use (X):

1. This device contains a thin wall diaphragm less than 1 mm thickness that forms a boundary between zone 0 (process connection) and zone 1 (all other parts of the equipment). The model code and datasheet are to be consulted for details of the diaphragm material. Installation, maintenance and use shall take into account the environmental conditions to which the diaphragm will be subjected. The manufacturer’s instructions for installation and maintenance shall be followed in detail to assure safety during its expected lifetime.
2. Flameproof joints are not intended for repair.
3. Non-standard paint options may cause risk from electrostatic discharge. Avoid installations that could cause electrostatic build-up on painted surfaces, and only clean the painted surfaces with a damp cloth. If paint is ordered through a special option code, contact the manufacturer for more information.

EAC - Belarus, Kazakhstan, Russia

EM Technical Regulation Customs Union (EAC) Flameproof and Dust

Certificate: RU C-US.AA87.B.00378

Markings: Ga/Gb Ex d IIC T6...T4 X
Ex tb IIIC T105 °C T₅₀₀ 95 °C Db X
Ex ta IIIC T105 °C T₅₀₀ 95 °C Da X

Special Condition for Safe Use (X):

1. See Certificate for Special Conditions for safe use.

IM Technical Regulation Customs Union (EAC) Intrinsic Safety

Certificate: RU C-US.AA87.B.00378

Markings: 0Ex ia IIC T4 Ga X

Special Condition for Safe Use (X):

1. See Certificate for Special Conditions for safe use.

Combinations

K1 Combination of E1, I1, N1, and ND

K7 Combination of E7, I7, and N7

KC Combination of E1, E5, I1, and I5

KD Combination of E1, E5, E6, I1, I5, and I6

KG Combination of IA, IE, IF, and IG

KM Combination of EM and IM

Dimensional drawings

Figure 2. Plantweb Housing

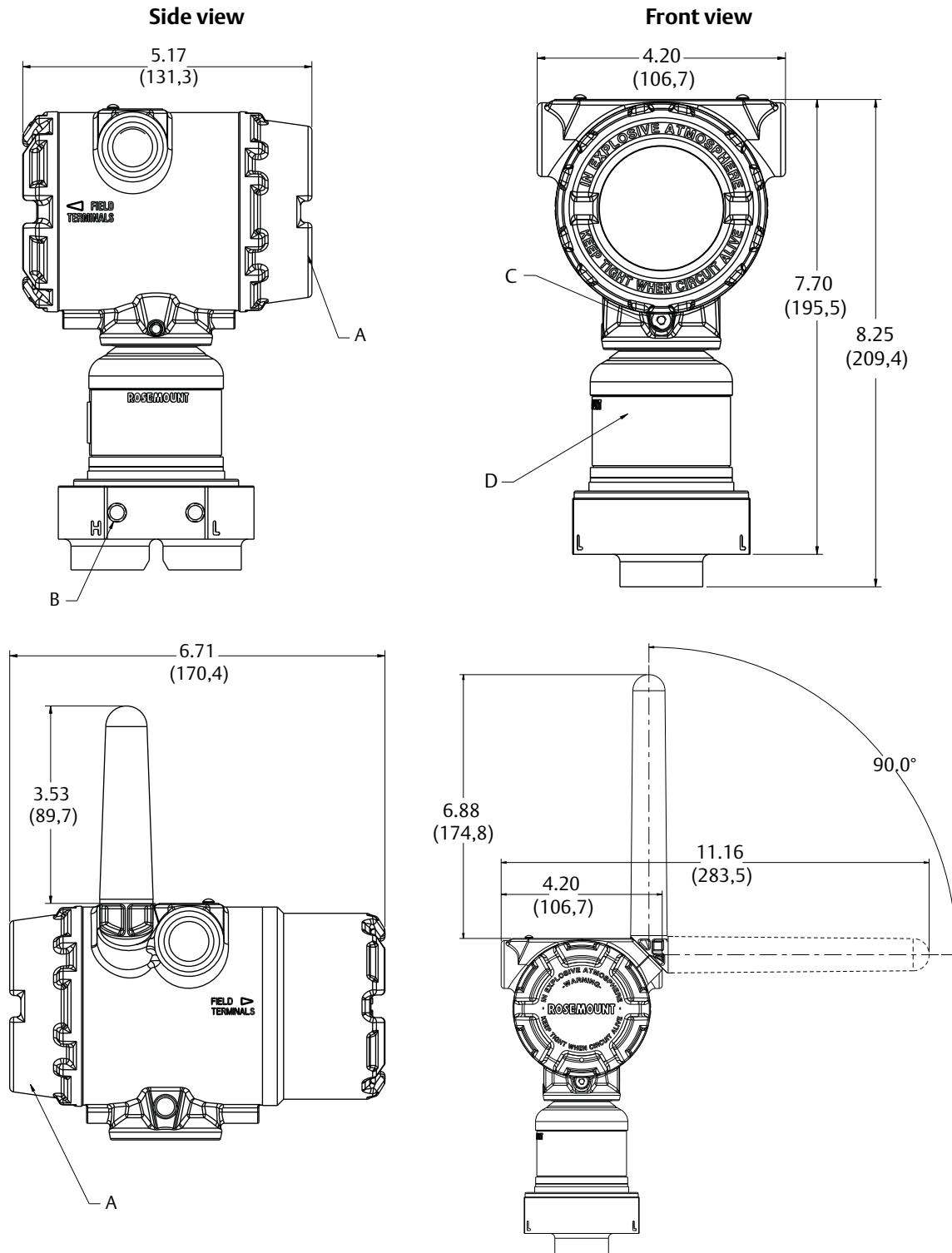

- A. Digital display cover
 - B. Bracket mounting holes (5/16–18 UNC, two places)
 - C. Housing rotation set screw
- Dimensions are in inches (millimeters).

- D. Nameplate
- E. Digital display cover

Figure 3. Other Housings

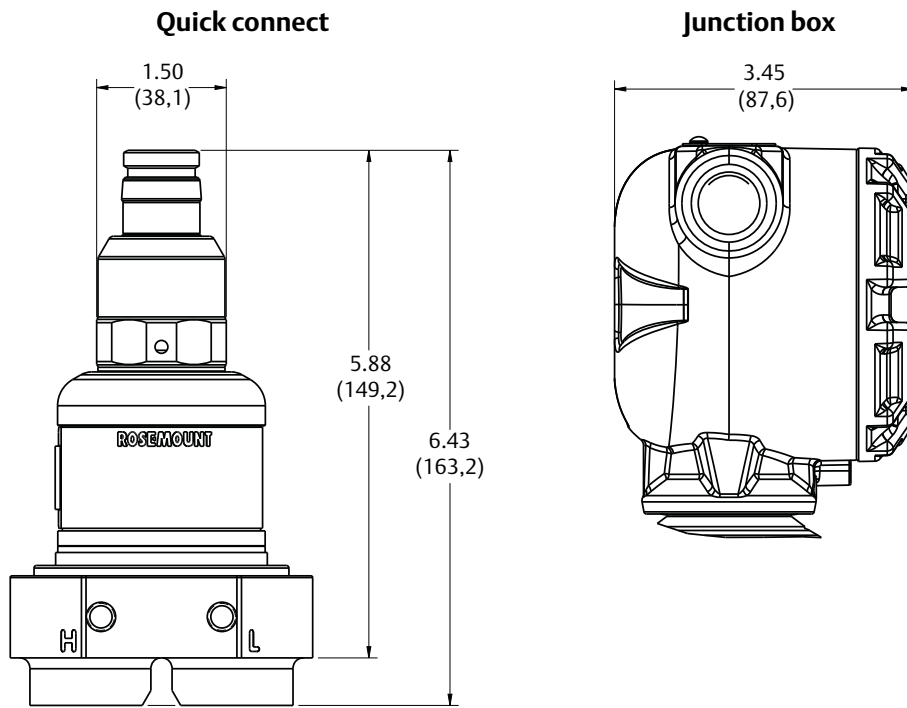

Dimensions are in inches (millimeters).

Figure 4. Remote Meter Option

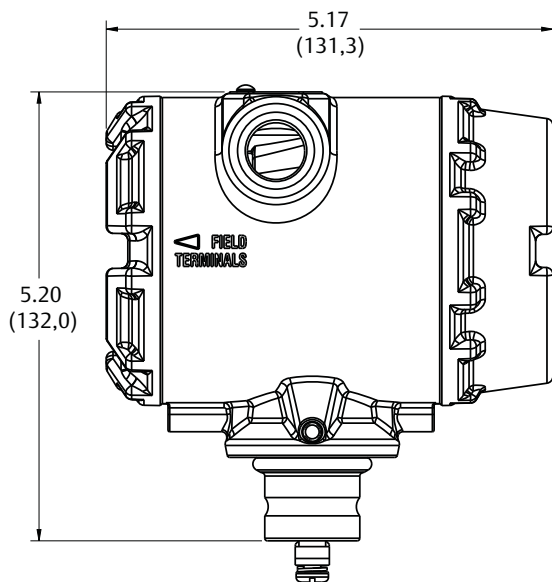
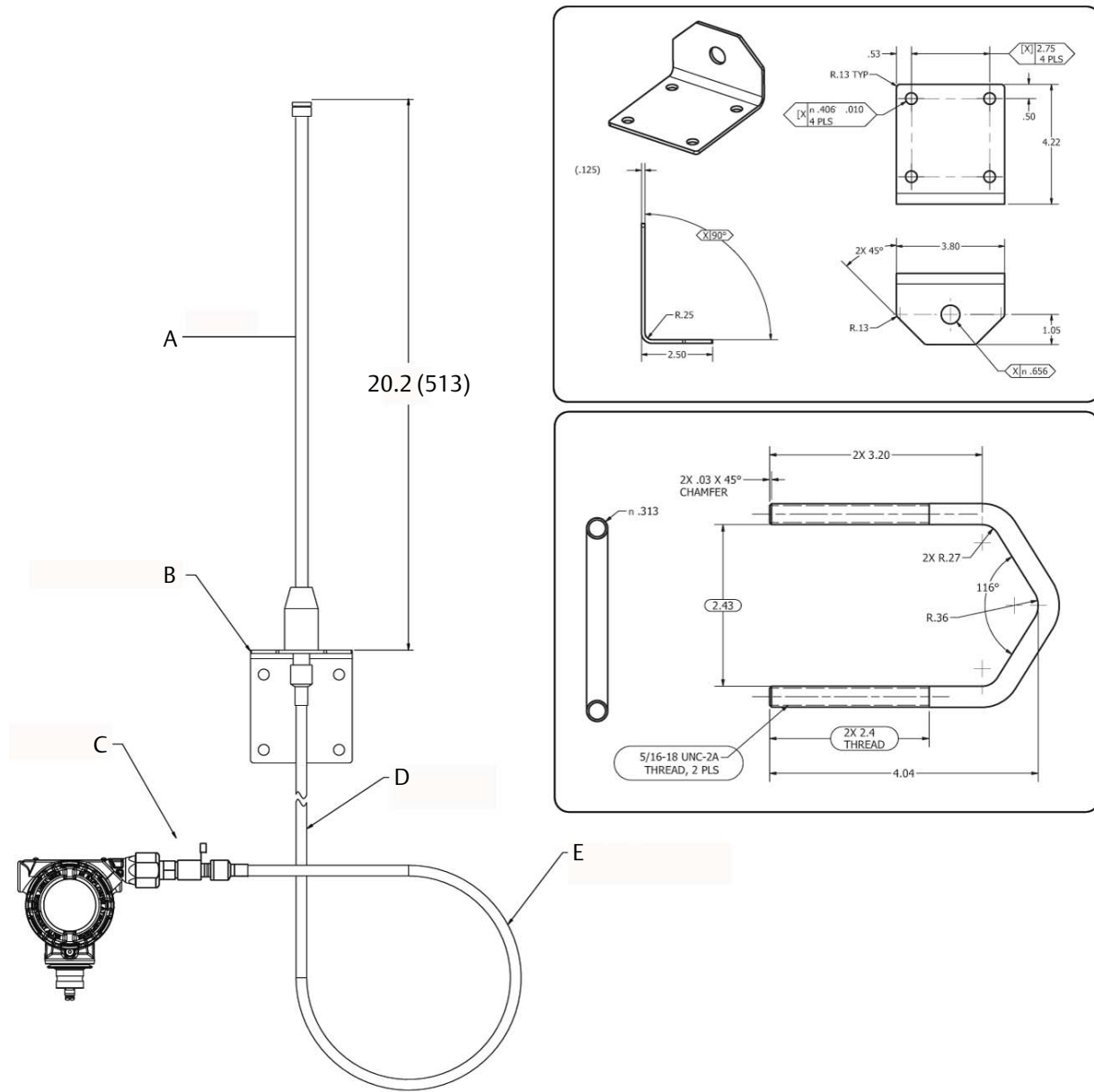

Figure 5. High Gain, Remote Mount Antenna (WN Option)



- A. Antenna
- B. Mounting bracket
- C. Lightning arrester
- D. 25 ft. (7,6 m) cable
- E. Min drip loop Ø12-in. (0.3 m)

Dimensions are in inches (millimeters).

Figure 6. Traditional Mounting Configurations

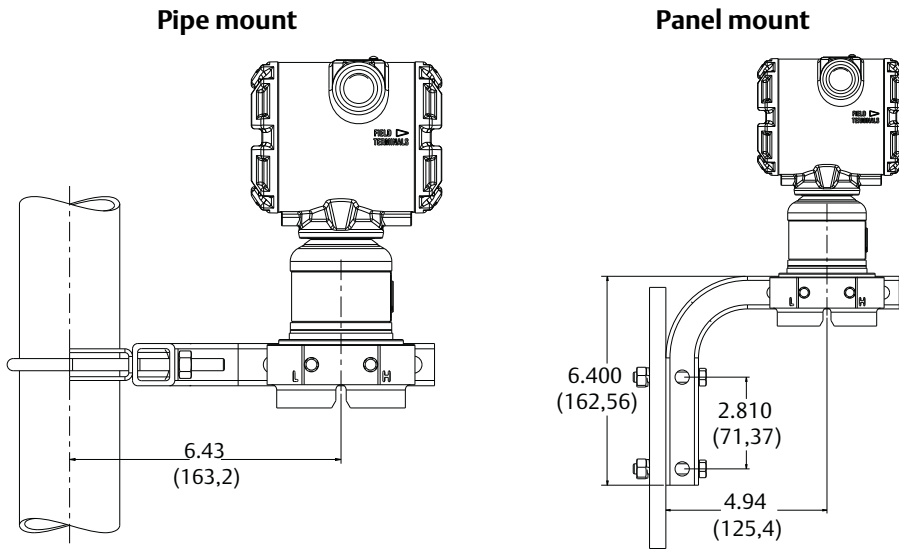

Dimensions are in inches (millimeters).

Figure 7. Remote Display Mounting Configurations (B4 Bracket)

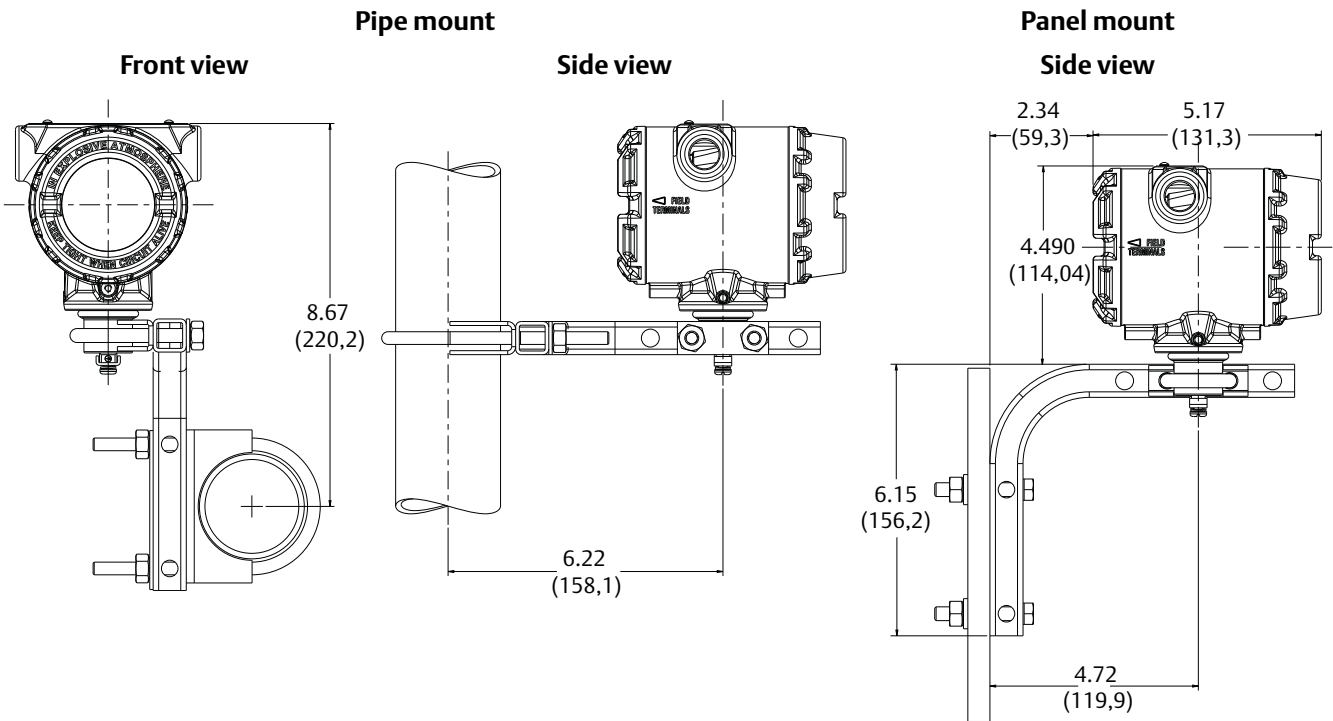

Dimensions are in inches (millimeters).

Options

Transmitter options

Standard configuration

Unless otherwise specified, transmitter is shipped as follows:

Engineering units	
Rosemount 3051SHP	inH ₂ O (Range 6 and 7) psi (Range 8)
4 mA ⁽¹⁾ :	0 (engineering units above)
20 mA ⁽¹⁾ :	Upper range limit
Output	Linear
External buttons	None
Drain/vent	Specified model code option
LCD display	None
Alarm ⁽¹⁾	High
Software tag	Blank
Damping	0.4 seconds ⁽²⁾

1. Not applicable to FOUNDATION Fieldbus or wireless.
2. For Fieldbus protocols, default damping is 1 second.

Custom configuration⁽¹⁾

If option code C1 is ordered, the customer may specify the following data in addition to the standard configuration parameters.

- Output information
- Transmitter information
- LCD display configuration
- Hardware selectable information
- Signal selection
- Wireless information
- Scaled variable
- and more

For Rosemount 3051SHP, refer to the Rosemount 3051S High Static Differential Pressure [Configuration Data Sheet](#).

Tagging (three options available)

- Standard SST hardware tag is wired to the transmitter. Tag character height is 0.125-in. (3,18 mm), 56 characters maximum.
- Tag may be permanently stamped on transmitter nameplate upon request, 56 characters maximum.
- Tag may be stored in transmitter memory. Character limit is dependent on protocol.
 - HART 4–20mA: 8 characters
 - WirelessHART: 32 characters
 - FOUNDATION Fieldbus: 32 characters

Commissioning tag⁽²⁾

A temporary commissioning tag is attached to all transmitters. The tag indicates the device ID and allows an area for writing the location.

Output information

Output range points must be the same unit of measure. Available units of measure include:

Pressure			
atm	inH ₂ O @4 °C	g/cm ²	psi
mbar	mmH ₂ O	kg/cm ²	torr
bar	mmHg	Pa	cmH ₂ O @4 °C ⁽¹⁾
inH ₂ O	mmH ₂ O @4 °C	kPa	mH ₂ O @4 °C ⁽¹⁾
inHg	ftH ₂ O	MPa	ftH ₂ O @60 °F ⁽¹⁾
hPa ⁽¹⁾	inH ₂ O @60 °F	kg/m ² ⁽¹⁾	cmHg @0 °C ⁽¹⁾
mHg @0 °C ⁽¹⁾	psf ⁽¹⁾	ftH ₂ O @4 °C ⁽¹⁾	

1. Field configurable only, not available for factory calibration or custom configuration (option code C1 "Software configuration").

Display and interface options

M5 Digital display

- 3-line, 7-digit LCD display
- Direct reading of digital data for higher accuracy
- Displays user-defined flow, level, volume, or pressure units
- Displays diagnostic messages for local troubleshooting
- 90° rotation capability for easy viewing

1. Not applicable to FOUNDATION Fieldbus Protocol.

2. Only applicable to FOUNDATION Fieldbus Protocol.

Configuration buttons

Transmitter will ship with no buttons unless option D1 (hardware adjustments) or DA2 (Advanced HART Diagnostics Suite) are specified.

The Rosemount Wireless Transmitter is available with a digital zero button installed with or without the LCD display digital display.

Transient protection (option code T1)

Tested in accordance with IEEE C62.41.2-2002, location category B

6 kV crest (0.5 μ s – 100 kHz)

3 kA crest (8 x 20 μ s)

6 kV crest (1.2 x 50 μ s)

Conduit plug

DO 316 SST conduit plug
Single 316 SST conduit plug replaces carbon steel plug

Bracket option

B4 Bracket for 2-in. pipe or panel mounting



- Bracket for mounting of transmitter on 2-in. pipe or panel
- 316 SST construction with SST bolts

Other publications

For additional information, go to Emerson.com.



Global Headquarters

Emerson Automation Solutions

6021 Innovation Blvd.
Shakopee, MN 55379, USA
 +1 800 999 9307 or +1 952 906 8888
 +1 952 949 7001
 RFQ.RMD-RCC@Emerson.com



North America Regional Office

Emerson Automation Solutions

8200 Market Blvd.
Chanhassen, MN 55317, USA
 +1 800 999 9307 or +1 952 906 8888
 +1 952 949 7001
 RMT-NA.RCCRFQ@Emerson.com

Latin America Regional Office

Emerson Automation Solutions

1300 Concord Terrace, Suite 400
Sunrise, FL 33323, USA
 +1 954 846 5030
 +1 954 846 5121
 RFQ.RMD-RCC@Emerson.com

Europe Regional Office

Emerson Automation Solutions Europe GmbH

Neuhofstrasse 19a P.O. Box 1046
CH 6340 Baar
Switzerland
 +41 (0) 41 768 6111
 +41 (0) 41 768 6300
 RFQ.RMD-RCC@Emerson.com

Asia Pacific Regional Office

Emerson Automation Solutions

1 Pandan Crescent
Singapore 128461
 +65 6777 8211
 +65 6777 0947
 Enquiries@AP.Emerson.com

Middle East and Africa Regional Office

Emerson Automation Solutions

Emerson FZE P.O. Box 17033
Jebel Ali Free Zone - South 2
Dubai, United Arab Emirates
 +971 4 8118100
 +971 4 8865465
 RFQ.RMTMEA@Emerson.com

 [Linkedin.com/company/Emerson-Automation-Solutions](https://www.linkedin.com/company/Emerson-Automation-Solutions)

 [Twitter.com/Rosemount_News](https://twitter.com/Rosemount_News)

 [Facebook.com/Rosemount](https://www.facebook.com/Rosemount)

 [Youtube.com/user/RosemountMeasurement](https://www.youtube.com/user/RosemountMeasurement)

 [Google.com/+RosemountMeasurement](https://www.google.com/+RosemountMeasurement)

Emerson Terms and Conditions of Sale are available upon request.
The Emerson logo is a trademark and service mark of Emerson Electric Co.
Rosemount is a mark of one of the Emerson family of companies. All other
marks are the property of their respective owners.
© 2018 Emerson. All rights reserved.