

# Rosemount™ 248 Wireless Temperature Transmitter



**Contents**

About this guide..... 3

Wireless considerations..... 6

Physical installation..... 7

Verify operations..... 11

Reference information..... 14

Power module replacement..... 17

Product certifications..... 19

Declaration of Conformity..... 23

China RoHS..... 26

# 1 About this guide

This guide provides basic guidelines to install the Rosemount 248 Wireless Temperature Transmitter. It does not provide instructions for detailed configuration, diagnostics, maintenance, service, troubleshooting, or installations. Refer to the Rosemount 248 Temperature Transmitter [Reference Manual](#) for more instruction. The manual and this guide are also available electronically at [Emerson.com/Rosemount](http://Emerson.com/Rosemount).

## 1.1 Safety messages

### **▲ WARNING**

**Failure to follow these installation guidelines could result in death or serious injury.**

Ensure only qualified personnel perform the installation.

#### **Explosions**

Explosions could result in death or serious injury.

Installation of device in an explosive environment must be in accordance with appropriate local, national, and international standards, codes, and practices.

Review the Hazardous Locations Certifications for any restrictions associated with a safe installation.

#### **Process leaks**

Process leaks could result in death or serious injury.

Install and tighten thermowells and sensors before applying pressure.  
Do not remove the thermowell while in operation.

#### **Electrical shock**

Electrical shock could cause death or serious injury.

Avoid contact with the leads and terminals. High voltage that may be present on leads can cause electrical shock.

Unless marked, the conduit/cable entries in the housing use a ½-14 NPT thread form. Entries marked "M20" are M20 × 1.5 thread form. On devices with multiple conduit entries, all entries will have the same thread form. Only use plugs, adapters, glands, or conduit with a compatible thread form when closing these entries.

When installing in a hazardous location, use only appropriately listed or Ex certified plugs, glands, or adapters in cable/conduit entries.

**⚠ WARNING**

**This device complies with Part 15 of the FCC Rules. Operation is subject to the following conditions:**

This device may not cause harmful interference.

This device must accept any interference received, including interference that may cause undesired operation.

This device must be installed to ensure a minimum antenna separation distance of 8-in. (20 cm) from all persons.

The power module may be replaced in a hazardous area. The power module has surface resistivity greater than one gigaohm and must be properly installed in the wireless device enclosure. Care must be taken during transportation to and from the point of installation to prevent electrostatic charge build-up.

**Physical access**

Unauthorized personnel may potentially cause significant damage to and/or misconfiguration of end users' equipment. This could be intentional or unintentional and needs to be protected against.

Physical security is an important part of any security program and fundamental to protecting your system. Restrict physical access by unauthorized personnel to protect end users' assets. This is true for all systems used within the facility.

**NOTICE****Power module considerations (Green Power Module, model number 701PGNKF)**

The green power module with the wireless unit contains one "D" size primary lithium-thionyl chloride battery (model number 701PGNKF). Each battery contains approximately 5.0 grams of lithium. Under normal conditions, the battery materials are self-contained and are not reactive as long as the batteries and the pack integrity are maintained. Care should be taken to prevent thermal, electrical or mechanical damage. Contacts should be protected to prevent premature discharge.

Battery hazards remain when cells are discharged.

Power modules should be stored in a clean and dry area. For maximum battery life, storage temperature should not exceed 86 °F (30 °C).

## NOTICE

### **Shipping considerations for wireless products (lithium batteries: Green Power Module, model number 701PGNKF)**

The unit was shipped to you without the power module installed. Remove the power module prior to shipping.

Each power module contains one “D” size primary lithium battery. Primary lithium batteries are regulated in transportation by the U.S. Department of Transportation, and are also covered by IATA (International Air Transport Association), ICAO (International Civil Aviation Organization), and ARD (European Ground Transportation of Dangerous Goods). It is the responsibility of the shipper to ensure compliance with these or any other local requirements. Consult current regulations and requirements before shipping.

---

## 2 Wireless considerations

### 2.1 Power up sequence

The Rosemount 248 Wireless Transmitter and all other devices should be installed only after the Wireless Gateway (“Gateway”) has been installed and is functioning properly. Wireless devices should also be powered up in order of proximity from the Gateway, beginning with the closest. This will result in a simpler and faster network installation. Enable **Active Advertising** on the Gateway to ensure new devices join the network faster. For more information see the Emerson Wireless Gateway [Reference Manual](#).

### 2.2 Antenna position

The internal antenna is designed for multiple mounting orientations. The transmitter should be mounted according to best practices for your temperature measurement application. The transmitter should be approximately 3 ft. (1 m) from any large structure or building to allow clear communication to other devices.

### 2.3 Field Communicator connections

The power module must be installed in the device for the Field Communicator to interface with the transmitter. The Field Communicator connections are located on the Green Power Module. To communicate to the transmitter, begin by removing the power module cover. This will expose the HART® communication terminals located on the Green Power Module. Next, connect the Field Communicator leads to the COMM port connections on the Green Power Module.

This transmitter uses the Green Power Module; order model number 701PGNKF. The power module is keyed and can only be inserted in one orientation. Field communication with this device requires a HART-based Field Communicator. Refer to [Figure 2-1](#) for instructions on connecting the Field Communicator to the transmitter.

**Figure 2-1: Field Communicator Connection**

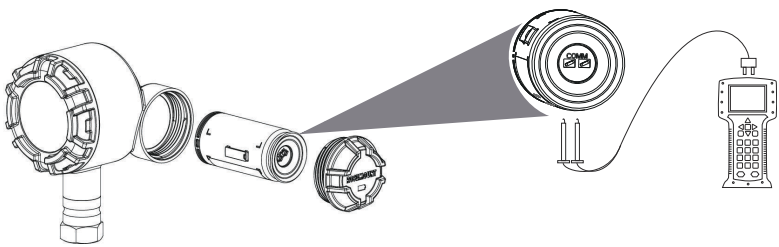

## 3 Physical installation

The transmitter can be installed in one of two configurations: Direct Mount, where the sensor is connected directly to the transmitter conduit entry, or Remote Mount, where the sensor is mounted separately from the transmitter housing, then connected to the transmitter via conduit. Choose the installation sequence that corresponds to the mounting configuration.

Upon installation of the transmitter, ensure that the conduit entry has an installed conduit fitting or cable gland with approved thread sealant.

### 3.1 Direct mount

The direct mount installation should not be used when installing with a Swagelok® fitting.

#### Procedure

1. Remove the transmitter enclosure cover.
2. Remove the LCD display (if applicable).
3. Loosen the captive screws and remove LCD display adapter plate (if applicable).

**Figure 3-1: Exploded View of LCD Display Assembly**

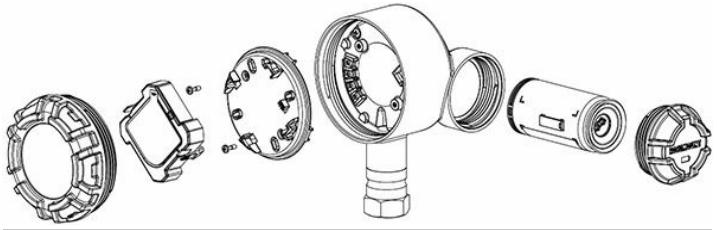

4. Attach the sensor to the transmitter housing using the threaded conduit entry. Be sure to use an approved thread sealant on all connections.
5. Attach the sensor wiring to the terminals as indicated on [Figure 5-1](#).
6. Reattach and secure LCD display adapter plate to 5 in-lb of torque (if applicable).
7. Reattach the LCD display (if applicable).
8. Reattach and tighten the transmitter enclosure cover.
9. Remove the power module cover.
10. Connect the Green Power Module.
11. Reattach and tighten the power module cover.

12. Always ensure a proper seal by installing the electronics housing cover(s) so that polymer contacts polymer (i.e. no O-ring visible). Use Rosemount O-rings.
13. Provide 1.75-in. (45 mm) of clearance for units without an LCD display. Provide 3-in. (76 mm) of clearance for units with an LCD display for cover removal.

**Figure 3-2: Direct Mount**

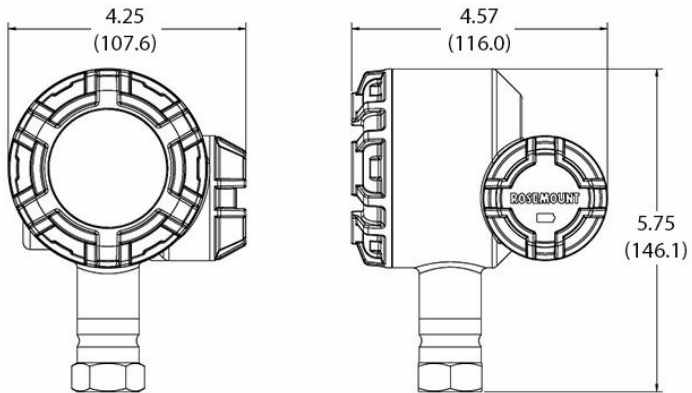

Dimensions are in inches (millimeters).

**Note**

Wireless devices should be powered up in order of proximity from the Gateway, beginning with the closest device to the Gateway. This will result in a simpler and faster network installation.

## 3.2 Remote mount

**Procedure**

1. Remove the transmitter enclosure cover.
2. Remove the LCD display (if applicable).
3. Loosen the captive screws and remove LCD display adapter plate (if applicable). Refer to [Figure 3-3](#).

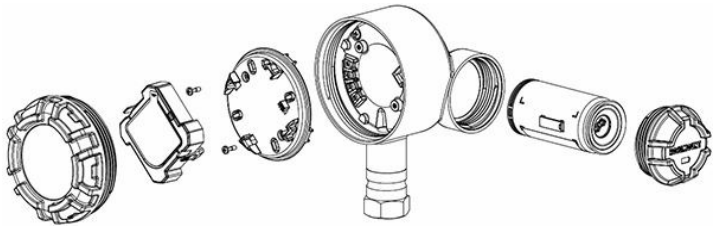

---

**Figure 3-3: Exploded View of LCD Display Assembly**

- 
4. Run wiring (and conduit, if necessary) from the sensor to the transmitter.

**Note**

Use an ½-in. NPT when mating conduit to the transmitter.

---

5. Pull the wiring through the threaded conduit entry of the transmitter.
6. Attach the sensor wiring to the terminals as indicated on [Figure 5-1](#).
7. Reattach and secure LCD display adapter plate to 5 in-lb of torque (if applicable).
8. Reattach the LCD display (if applicable).
9. Reattach and tighten the transmitter enclosure cover.
10. Remove the power module cover.
11. Connect the Green Power Module.
12. Reattach and tighten the power module cover.
13. Always ensure a proper seal by installing the electronics housing cover(s) so that polymer contacts polymer (i.e. no O-ring visible). Use Rosemount O-rings.
14. Provide 1.75-in. (45 mm) of clearance for units without an LCD display. Provide 3-in. (76 mm) of clearance for units with an LCD display for cover removal.

**Figure 3-4: Remote Mount**

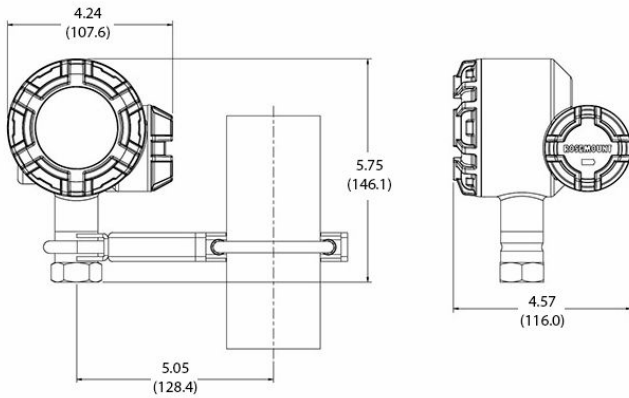

Dimensions are in inches (millimeters).

**Note**

Wireless devices should be powered up in order of proximity from the Wireless Gateway, beginning with the closest device to the Gateway. This will result in a simpler and faster network installation.

## 4 Verify operations

Operations can be verified in four locations:

- at the device via the Local Display
- using the Field Communicator
- at the Gateway's integrated web interface
- using AMS Wireless Configurator or AMS Device Manager

### 4.1 Local display

During normal operation, the LCD display will display the PV value at the configured update rate.

For Device Status screens, see LCD display screen messages on Rosemount 248 Wireless [Reference Manual](#).

### 4.2 Field Communicator

For HART® communication, a Rosemount 248 Wireless DD is required. To obtain the latest DD, visit the Emerson Easy Upgrade site at:

[Emerson.com/Rosemount/Device-Install-Kits](https://emerson.com/Rosemount/Device-Install-Kits)

The communication status may be verified in the wireless device using the following Fast Key sequence.

**Table 4-1: Fast Key Sequence**

| Function       | Key sequence | Menu items  |
|----------------|--------------|---|
| Communications | 3, 4         | Comm Status, Join Mode, Available Neighbors, Advertisement, Join Attempts |

### 4.3 Emerson Wireless Gateway

In the integrated web interface from the Gateway, navigate to the **Explorer** → **Status** page. This page shows whether the device has joined the network and if it is communicating properly.

#### Note

It may take several minutes for the device to join the network. If the device joins the network and immediately has an alarm present, it is likely due to sensor configuration. Check the sensor wiring (see [Figure 5-1](#)) and configuration table ([Table 5-1](#)).

Figure 4-1: Wireless Gateway Network Settings

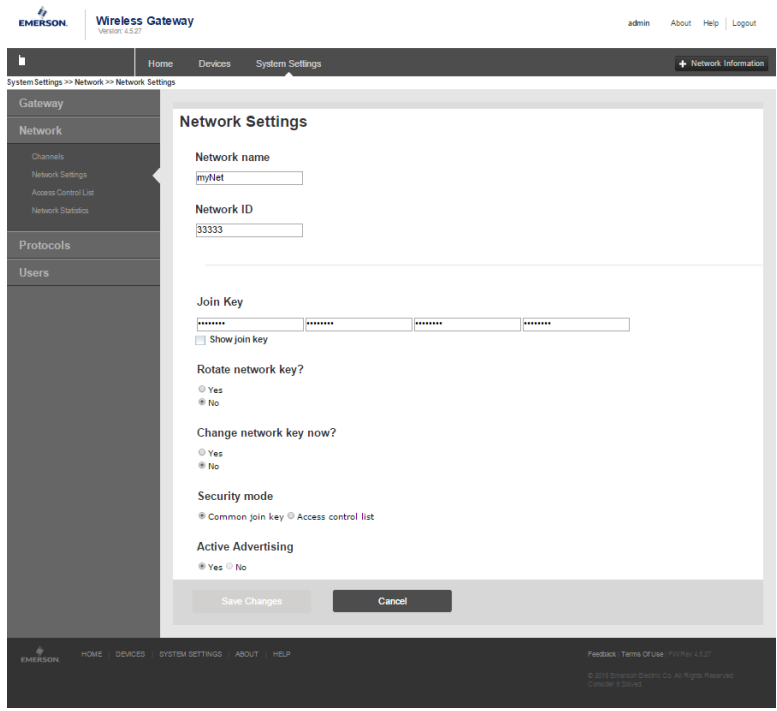

## 4.4 AMS Wireless Configurator

When the device has joined the network, it will appear in the **Wireless Configurator** window as illustrated in figure below. For HART® communication, a Rosemount 248 Wireless DD is required. To obtain the latest DD, visit the Emerson Easy Upgrade site at:

[Emerson.com/Rosemount/Device-Install-Kits](http://Emerson.com/Rosemount/Device-Install-Kits)

**Figure 4-2: AMS Wireless Configurator**

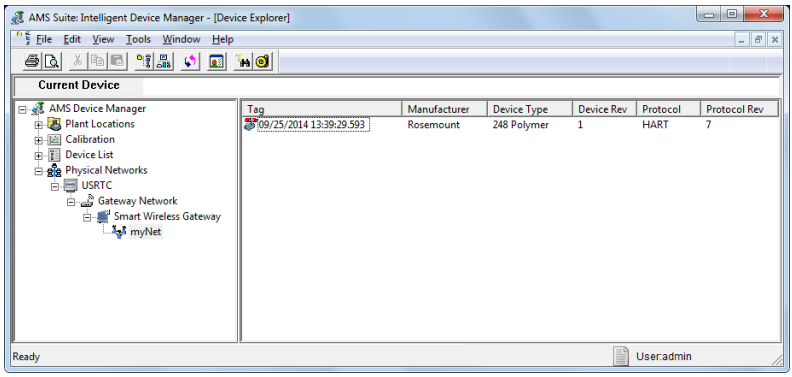

## 4.5 Troubleshooting

If the device is not joining to the network, check to make sure that you have a power supply in your device. If the device is not joined to the network after power up, verify the correct configuration of the Network ID and Join Key, and verify that Active Advertising has been enabled on the Wireless Gateway. The Network ID and Join Key in the device must match the Network ID and Join Key of the Gateway.

The Network ID and Join Key may be obtained from the Gateway on the **Setup** → **Network** → **Settings** page on the web server (see [Figure 4-1](#)). The Network ID and Join Key may be changed in the wireless device by using the following Fast Key sequence.

| Function               | Key sequence | Menu items      |
|------------------------|--------------|-----------------|
| Join Device to Network | 2,1,1        | Join to Network |

# 5 Reference information

Figure 5-1: Sensor Wiring

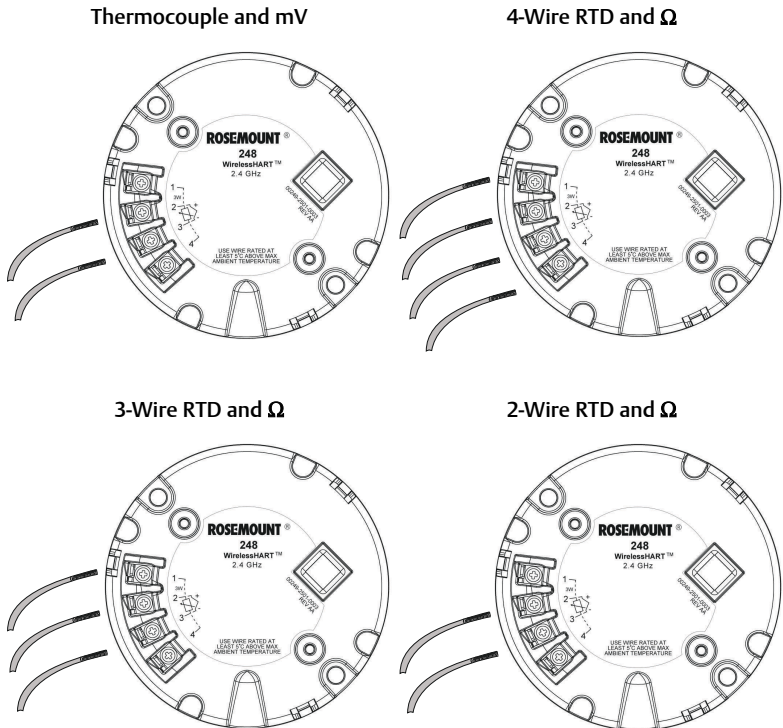
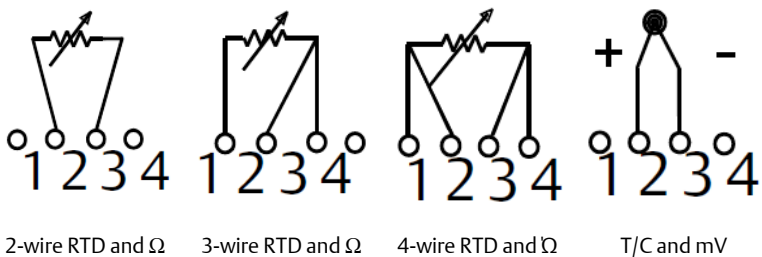

Figure 5-2: Sensor Connections



**Note**

Emerson provides 4-wire sensors for all single element RTDs. Use these RTDs in 3- or 2-wire configurations by leaving the unneeded leads disconnected and insulated with electrical tape.

**Table 5-1: WirelessHART® Fast Key Sequences**

| Function               | Key sequence | Menu items   |
|------------------------|--------------|--|
| Device Information     | 1, 7         | Identification, Revisions, Radio, Security   |
| Guided Setup           | 2, 1         | Join Device to Network, Configure Update Rate, Configure Sensor, Calibrate Sensor  |
| Manual Setup           | 2, 2         | Wireless, Process Sensor, Percent of Range, Device Temperatures, Device Information, Other                                     |
| Wireless Configuration | 2, 2, 1      | Network ID, Join to Network, Broadcast Info  |
| Sensor Calibration     | 3, 5, 2      | Sensor Value, Sensor Status, Current Lower Trim, Current Upper Trim, Lower Sensor Trim, Upper Sensor Trim, Recall Factory Trim |

**Figure 5-3: RTD Lead Wire Configuration per IEC 60751**

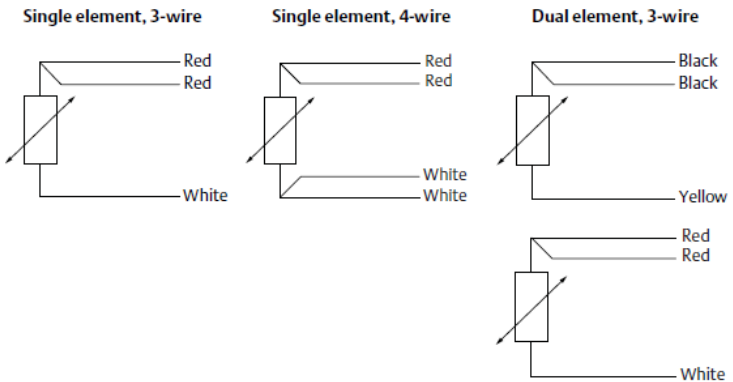

**Note**

To configure a single element, 4-wire RTD as a 3-wire system, connect only one white lead.

Insulate or terminate the unused white lead in a manner that prevents shorting to the ground.

To configure a single element, 4-wire RTD as a 2-wire system, connect matching colored wires first and then connect the paired wires to the terminal.

**Figure 5-4: Thermocouple Lead Wire Configurations**

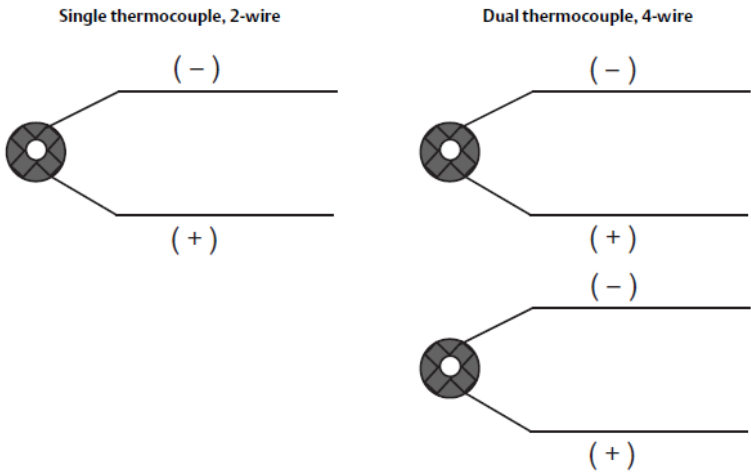

| Type | IEC 60584 thermocouple colors |        | ASTM E-230 thermocouple colors |        |
|------|-------------------------------|--------|--------------------------------|--------|
|      | POS(+)                        | NEG(-) | POS(+)                         | NEG(-) |
| J    | Black                         | White  | White                          | Red    |
| K    | Green                         | White  | Yellow                         | Red    |
| T    | Brown                         | White  | Blue                           | Red    |

**Note**

Dual thermocouple sensors are shipped with one pair of the wires shrink wrapped together.



## 6 Power module replacement

Expected power module life is 10 years at reference conditions.<sup>(1)</sup>

When power module replacement is required, remove the cover and remove the Green Power Module. Replace the Green Power Module (part number 701PGNKF) and replace the cover. Tighten to specification and verify operation.

**Figure 6-1: Exploded Power Module View**

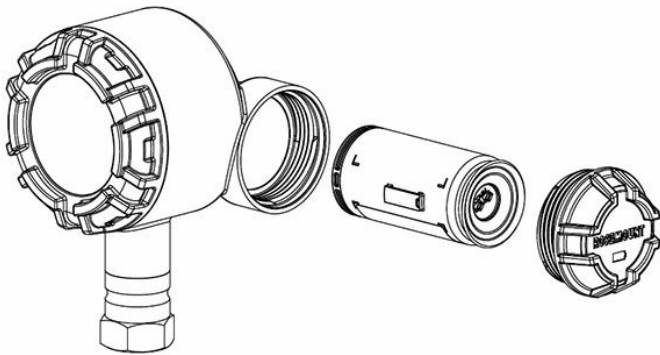

### 6.1 Handling considerations

The Green Power Module with the wireless unit contains one “D” size primary lithium-thionyl chloride battery (Green Power Module, model number 701PGNKF). Each battery contains approximately 5.0 grams of lithium. Under normal conditions, the battery materials are self-contained and are not reactive as long as the batteries and the pack integrity are maintained. Care should be taken to prevent thermal, electrical or mechanical damage.

Contacts should be protected to prevent premature discharge.

#### Note

Power modules should be stored in a clean and dry area. For maximum power module life, storage temperature should not exceed 86 °F (30 °C).

<sup>(1)</sup> Reference conditions are 70° F (21° C), transmit rate of once per minute, and routing data for three additional network devices.

**⚠ CAUTION**

Use caution when handling the power module, it may be damaged if dropped from heights in excess of 20 feet.

**⚠ WARNING**

Battery hazards remain when cells are discharged.

## 6.2 Environmental considerations

As with any battery, local environmental rules and regulations should be consulted for proper management of spent batteries. If no specific requirements exist, recycling through a qualified recycler is encouraged. Consult the material's safety data sheet for battery specific information.

## 6.3 Shipping considerations

The unit was shipped to you without the power module installed. Remove the power module prior to shipping the unit.

## 7 Product certifications

Rev 1.12

### 7.1 European Directive Information

A copy of the EU Declaration of Conformity can be found at the end of the Quick Start Guide. The most recent revision of the EU Declaration of Conformity can be found at [Emerson.com/Rosemount](https://www.emerson.com/Rosemount).

### 7.2 Ordinary Location Certification

As standard, the transmitter has been examined and tested to determine that the design meets the basic electrical, mechanical, and fire protection requirements by a nationally recognized test laboratory (NRTL) as accredited by the Federal Occupational Safety and Health Administration (OSHA).

### 7.3 Telecommunication compliance

All wireless devices require certification to ensure that they adhere to regulations regarding the use of the RF spectrum. Nearly every country requires this type of product certification. Emerson is working with governmental agencies around the world to supply fully compliant products and remove the risk of violating country directives or laws governing wireless device usage.

### 7.4 FCC and IC

This device complies with Part 15 of the FCC Rules. Operation is subject to the following conditions: This device may not cause harmful interference. This device must accept any interference received, including interference that may cause undesired operation. This device must be installed to ensure a minimum antenna separation distance of 20 cm from all persons.

### 7.5 North America

The US National Electrical Code® (NEC) and the Canadian Electrical Code (CEC) permit the use of Division marked equipment in Zones and Zone marked equipment in Divisions. The markings must be suitable for the area classification, gas, and temperature class. This information is clearly defined in the respective codes.

#### 7.5.1 USA

##### **15 USA Intrinsically Safe**

**Certificate** 70008071

**Standards** FM 3600: 2011; FM 3610: 2010; FM 3611: 2004; UL 61010-1: 2012; UL 50E: 2012; ANSI/IEC 60529:2004

**Markings** Intrinsically Safe: CL I, DIV 1, GP A, B, C, D; CL I, DIV 2, GP A, B, C, D; Class I, Zone 0, AEx ia IIC T4/T5 Ga; T4 ( $-50\text{ °C} \leq T_a \leq +70\text{ °C}$ ); T5 ( $-50\text{ °C} \leq T_a \leq +40\text{ °C}$ ); WHEN INSTALLED PER ROSEMOUNT DWG 00249-2020; TYPE 4X, IP66/67

See [Table 7-1](#) for entity parameters.

### Special Condition for Safe Use (X)

Battery exchange: The battery module can be changed inside hazardous gas-explosive locations. During battery change it must be assured that the connections are free from dust or dirt.

## 7.5.2 Canada

### 16 Canada Intrinsically Safe

**Certificate** 70008071

**Standards** CSA C22.2 No. 0-10; CSA C22.2 No. 94.2-07 (R2012); CSA C22.2 No. 213-M1987 (R2013); CAN/CSA-60079-0-11; CAN/CSA-60079-11-14; CAN/CSA C22.2 No. 60529-05; CAN/CSA-C22.2 No. 61010-1-12

**Markings** Intrinsically Safe: CL I, DIV 1, GP A, B, C, D; CL I, DIV 2, GP A, B, C, D; Ex ia IIC T4/T5 Ga; T4 ( $-50\text{ °C} \leq T_a \leq +70\text{ °C}$ ); T5 ( $-50\text{ °C} \leq T_a \leq +40\text{ °C}$ ); WHEN INSTALLED PER ROSEMOUNT DWG 00249-2020; TYPE 4X, IP66/67

See [Table 7-1](#) for entity parameters.

### Special Condition for Safe Use (X)

Battery exchange: The battery module can be changed inside hazardous gas-explosive locations. During battery change it must be assured that the connections are free from dust or dirt.

## 7.6 Europe

### 11 ATEX Intrinsic Safety

**Certificate** Baseefa14ATEX0359X

**Standards** EN IEC 60079-0: 2018; EN 60079-11: 2012

**Markings**  II 1 G Ex ia IIC T4/T5 Ga; T4 ( $-60\text{ °C} \leq T_a \leq +70\text{ °C}$ ); T5 ( $-60\text{ °C} \leq T_a \leq +40\text{ °C}$ )

See [Table 7-1](#) for entity parameters.

**Special Condition for Safe Use (X)**

The plastic enclosure may present a potential electrostatic ignition hazard and must not be rubbed or cleaned with a dry cloth.

**7.7 International****I7 IECEx Intrinsic Safety**

**Certificate** IECEx BAS 14.0158X

**Standards** IEC 60079-0: 2017; IEC 60079-11: 2011

**Markings** Ex ia IIC T4/T5 Ga; T4 ( $-60\text{ °C} \leq T_a \leq +70\text{ °C}$ ); T5 ( $-60\text{ °C} \leq T_a \leq +40\text{ °C}$ )

See [Table 7-1](#) for entity parameters.

**Special Condition for Safe Use (X)**

The plastic enclosure may present a potential electrostatic ignition hazard and must not be rubbed or cleaned with a dry cloth.

**7.8 Brazil****I2 INMETRO Intrinsic Safety**

**Certificate** UL-BR 15.0222X

**Standards** ABNT NBR IEC 60079-0: 2008 + Corrigendum 1:2011; ABNT NBR IEC 60079-11: 2009

**Markings** Ex ia IIC T4/T5 Ga; T4 ( $-60\text{ °C} \leq T_a \leq +70\text{ °C}$ ); T5 ( $-60\text{ °C} \leq T_a \leq +40\text{ °C}$ )

See [Table 7-1](#) for entity parameters.

**Special Condition for Safe Use (X)**

The plastic enclosure may present a potential electrostatic ignition hazard and must not be rubbed or cleaned with a dry cloth.

**7.9 China****I3 NEPSI Intrinsic Safety**

**Certificate** GYJ20.1147X

**Standards** GB3836.1-2010, GB3836.4-2010, GB3836.20-2010

**Markings** Ex ia IIC T4/T5 Ga; T4 ( $-60\text{ °C} \leq T_a \leq +70\text{ °C}$ ); T5 ( $-60\text{ °C} \leq T_a \leq +40\text{ °C}$ )

See [Table 7-1](#) for entity parameters.

**Special Conditions for Safe Use (X)**

1. Non-metallic parts incorporated in the enclosure of the product shall only be cleaned with a damp cloth to avoid electrostatic charge.
2. Must use Rosemount Model 701PGNKF SmartPower Green Power Module provided by the manufacture.

**7.10 Japan****I4 TIIS Intrinsic Safety**

|                    |  |
|--------------------|--|
| <b>Certificate</b> | CML 20JPN2243X   |
| <b>Markings</b>    | Ex ia IIC T4, T5 Ga (-60 °C ~ +40/70 °C)<br>See <a href="#">Table 7-1</a> for entity parameters. |

**Special Conditions for Safe Use (X)**

1. The plastic enclosure may present a potential electrostatic ignition hazard and must not be rubbed or cleaned with a dry cloth.
2. Power shall be provided only by a Model 701PGNKF SmartPower Green Power Module.

**7.11 EAC****IM Technical Regulation Customs Union (EAC) Intrinsic Safety**

**Markings** 0Ex ia IIC T4, T5 Ga X, T5 (-60 °C ≤ T<sub>a</sub> ≤ +40 °C), T4 (-60 °C ≤ T<sub>a</sub> ≤ +70 °C); IP66/IP68



**Specific Condition for Safe Use (X)**

See certificate for special conditions.

**Table 7-1: Entity Parameters**

|                            |         |
|----------------------------|---------|
| Voltage U <sub>O</sub>     | 6.6 V   |
| Current I <sub>O</sub>     | 26.2 mA |
| Power P <sub>O</sub>       | 42.6 mW |
| Capacitance C <sub>O</sub> | 11 μF   |
| Inductance L <sub>O</sub>  | 25 mH   |

# 8 Declaration of Conformity

## EU Declaration of Conformity

No: RMD 1082 Rev. L

---

We,

**Rosemount, Inc.**  
8200 Market Boulevard  
Chanhassen, MN 55317-9685  
USA

declare under our sole responsibility that the product,

**Rosemount™ 248 Wireless Temperature Transmitter**

manufactured by,

**Rosemount, Inc.**  
8200 Market Boulevard  
Chanhassen, MN 55317-9685  
USA

to which this declaration relates, is in conformity with the provisions of the European Union Directives, including the latest amendments, as shown in the attached schedule.

Assumption of conformity is based on the application of the harmonized standards and, when applicable or required, a European Union notified body certification, as shown in the attached schedule.



---

(signature)

Vice President of Global Quality

---

(function)

Chris LaPoint

---

(name)

24-Feb-2020

---

(date of issue)

Page 1 of 3



## EU Declaration of Conformity

No: RMD 1082 Rev. L

---

### EMC Directive (2014/30/EU)

Harmonized Standards:  
EN 61326-1: 2013  
EN 61326-2-3: 2013

---

### Radio Equipment Directive (RED) (2014/53/EU)

Harmonized Standards:  
EN 300 328 V2.1.1  
EN 301 489-1 V2.2.0  
EN 301 489-17 V3.2.0  
EN 61010-1: 2010  
EN 62479: 2010

---

### ATEX Directive (2014/34/EU)

#### Rosemount 248 Wireless Temperature Transmitter (Polymer housing)

Baseefa14ATEX0359X – Intrinsic Safety Certificate  
Equipment Group II, Category 1 G  
Ex ia IIC T4/T5 Ga  
Harmonized Standards:  
EN IEC 60079-0: 2018, EN60079-11: 2012





# EU Declaration of Conformity

No: RMD 1082 Rev. L

**ATEX Notified Body**

SGS FIMCO OY [Notified Body Number: 0598]  
P.O. Box 30 (Särkiniementie 3)  
00211 HELSINKI  
Finland

**ATEX Notified Body for Quality Assurance**

SGS FIMCO OY [Notified Body Number: 0598]  
P.O. Box 30 (Särkiniementie 3)  
00211 HELSINKI  
Finland

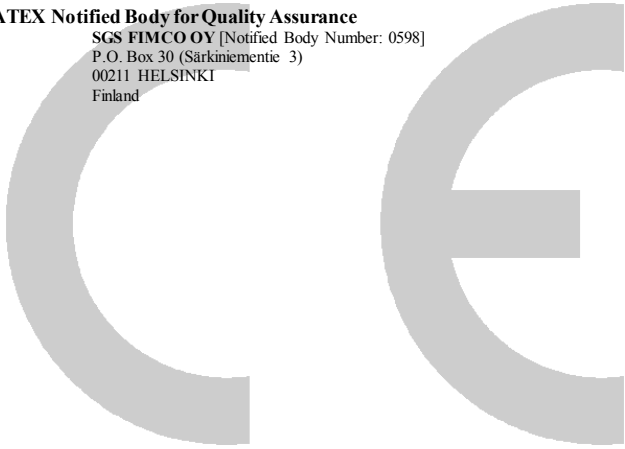

# 9 China RoHS

含有 China RoHS 管控物质超过最大浓度限值的部件型号列表 248  
List of 248 Parts with China RoHS Concentration above MCVs

| 部件名称<br>Part Name               | 有害物质 / Hazardous Substances |                      |                      |  |  |  |
|---------------------------------|-----------------------------|----------------------|----------------------|--|--|--|
|                                 | 铅<br>Lead<br>(Pb)           | 汞<br>Mercury<br>(Hg) | 镉<br>Cadmium<br>(Cd) | 六价铬<br>Hexavalent<br>Chromium<br>(Cr +6) | 多溴联苯<br>Polybrominated<br>biphenyls<br>(PBB) | 多溴联苯醚<br>Polybrominated<br>diphenyl ethers<br>(PBDE) |
| 电子组件<br>Electronics<br>Assembly | X                           | ○                    | ○                    | ○  | ○  | ○  |
| 壳体组件<br>Housing<br>Assembly     | ○                           | ○                    | ○                    | X  | ○  | ○  |
| 传感器组件<br>Sensor<br>Assembly     | X                           | ○                    | ○                    | ○  | ○  | ○  |

本表格系依据 SJ/T11364 的规定而制作。

This table is proposed in accordance with the provision of SJ/T11364.

○: 意为该部件的所有均质材料中该有害物质的含量均低于 GB/T 26572 所规定的限量要求。

O: Indicate that said hazardous substance in all of the homogeneous materials for this part is below the limit requirement of GB/T 26572.

X: 意为在该部件使用的所有均质材料里，至少有一类均质材料中该有害物质的含量高于 GB/T 26572 所规定的限量要求。

X: Indicate that said hazardous substance contained in at least one of the homogeneous materials used for this part is above the limit requirement of GB/T 26572.

| 部件名称<br>Part Name               | 组装备件说明<br>Spare Parts Descriptions for Assemblies                      |
|---------------------------------|--|
| 电子组件<br>Electronics<br>Assembly | 电子线路板组件 Electronic Board Assemblies<br>端子块组件 Terminal Block Assemblies |
| 壳体组件<br>Housing<br>Assembly     | 电子外壳 Electrical Housing  |





### Emerson Automation Solutions

6021 Innovation Blvd.  
Shakopee, MN 55379, USA

+1 800 999 9307 or +1 952 906 8888

+1 952 949 7001

RFQ.RMD-RCC@Emerson.com

### Latin America Regional Office

Emerson Automation Solutions  
1300 Concord Terrace, Suite 400  
Sunrise, FL 33323, USA

+1 954 846 5030

+1 954 846 5121

RFQ.RMD-RCC@Emerson.com

### Asia Pacific Regional Office

Emerson Automation Solutions  
1 Pandan Crescent  
Singapore 128461

+65 6777 8211

+65 6777 0947

Enquiries@AP.Emerson.com

[Linkedin.com/company/Emerson-Automation-Solutions](https://www.linkedin.com/company/Emerson-Automation-Solutions)

[Twitter.com/Rosemount\\_News](https://twitter.com/Rosemount_News)

[Facebook.com/Rosemount](https://www.facebook.com/Rosemount)

[Youtube.com/user/RosemountMeasurement](https://www.youtube.com/user/RosemountMeasurement)

### North America Regional Office

Emerson Automation Solutions  
8200 Market Blvd.

Chanhassen, MN 55317, USA

+1 800 999 9307 or +1 952 906 8888

+1 952 949 7001

RMT-NA.RCCRFQ@Emerson.com

### Europe Regional Office

Emerson Automation Solutions Europe  
GmbH

Neuhofstrasse 19a P.O. Box 1046

CH 6340 Baar

Switzerland

+41 (0) 41 768 6111

+41 (0) 41 768 6300

RFQ.RMD-RCC@Emerson.com

### Middle East and Africa Regional Office

Emerson Automation Solutions

Emerson FZE P.O. Box 17033

Jebel Ali Free Zone - South 2

Dubai, United Arab Emirates

+971 4 8118100

+971 4 8865465

RFQ.RMTMEA@Emerson.com

©2021 Emerson. All rights reserved.

Emerson Terms and Conditions of Sale are available upon request. The Emerson logo is a trademark and service mark of Emerson Electric Co. Rosemount is a mark of one of the Emerson family of companies. All other marks are the property of their respective owners.