

Rosemount™ 248 Wireless Temperature Transmitter



- Standard temperature transmitter offers a wireless solution for process monitoring
- Optimize plant efficiency and increase measurement reliability with industry-proven capabilities and specifications
- Emerson Wireless delivers innovative wireless solutions for temperature measurement and overall transmitter performance
- Explore the benefits of Complete Point Solutions™ from Emerson.

Features and benefits

Standard temperature transmitter offers a cost effective solution for wireless process monitoring

- Single sensor capability with universal sensor inputs (RTD, T/C, mV, and ohms)
- IEC-approved *WirelessHART*® protocol
- Large LCD display

Optimize plant efficiency and increase measurement reliability with industry-proven capabilities and specifications

- One-year stability rating reduces maintenance costs
- User-centric device dashboards communicate important diagnostics and ensure process health
- Open/short sensor diagnostics assist with detecting issues in the sensor loop
- Compensation for ambient temperatures enhances transmitter performance
- Four user-configurable alerts provide increased process information and measurement point insight

Wireless delivers innovative wireless solutions for temperature measurement and overall transmitter performance

- Self-organizing network delivers information rich data with >99 percent data reliability and establishes a highly stable network
- Smart Wireless capabilities extend the full benefits of Plantweb™ to previously inaccessible temperature measurement locations
- Emerson SmartPower™ solutions provide an intrinsically safe Power Module, allowing field replacements without removing the transmitter from the process, keeping personnel safe and reducing maintenance costs
- Emerson’s layered approach to wireless network security ensures that data transmissions are secure

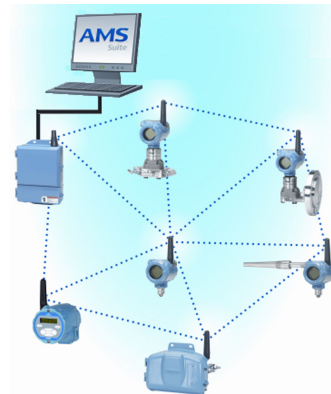

Contents

Features and benefits..... 2

Ordering Information..... 4

Specifications..... 8

Product certifications..... 15

Dimensional Drawings..... 19

Explore the benefits of a complete point solution from Rosemount Temperature Measurement

- An “Assemble To Sensor” option enables Emerson to provide a complete point temperature solution, delivering an installation-ready transmitter, and sensor assembly.
- Emerson offers a selection of RTDs, thermocouples, and thermowells that bring superior durability and Rosemount reliability to temperature sensing, complementing the Rosemount Transmitter portfolio.

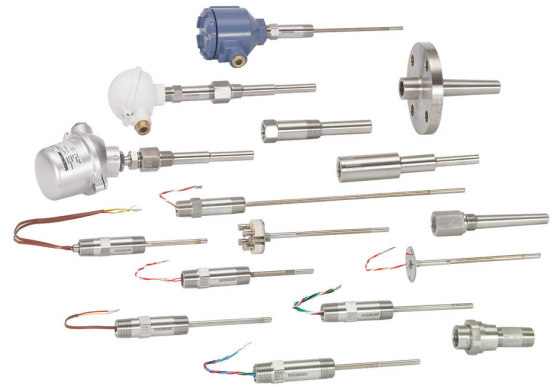

Experience global consistency and local support from numerous worldwide Rosemount Temperature manufacturing sites

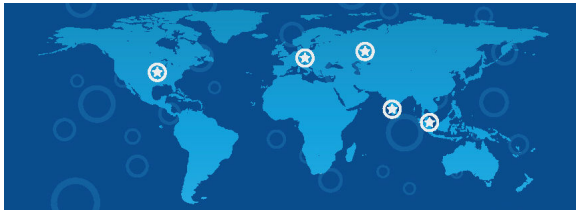

- Experienced Instrumentation Consultants help select the right product for any temperature application and advise on best installation practices
- An extensive global network of Emerson service and support personnel can be on-site when and where they are needed
- World-class manufacturing provides globally consistent product from every factory and the capacity to fulfill the needs of any project, large or small

Access information when you need it with asset tags

Newly shipped devices include a unique QR code asset tag that enables you to access serialized information directly from the device. With this capability, you can:

- Access device drawings, diagrams, technical documentation, and troubleshooting information in your MyEmerson account
- Improve mean time to repair and maintain efficiency
- Ensure confidence that you have located the correct device
- Eliminate the time-consuming process of locating and transcribing nameplates to view asset information

Ordering Information



The Rosemount 248 Wireless Temperature Transmitter has a rugged design and industry-proven capabilities and specifications.

Transmitter features include:

- IEC-approved *WirelessHART*[®] protocol (option code WA3)
- Large LCD display (option code M5)
- Internal antenna (option code WP5)
- 3-point calibration certificate (option code Q4)
- Assemble to Sensor options (option code XA)

[CONFIGURE >](#)

[VIEW PRODUCT >](#)

Online Product Configurator

Many products are configurable online using our Product Configurator. Select the **Configure** button or visit our [website](#) to start. With this tool's built-in logic and continuous validation, you can configure your products more quickly and accurately.

Model codes

Model codes contain the details related to each product. Exact model codes will vary; an example of a typical model code is shown in [Figure 1](#).

Figure 1: Model Code Example

3144P D1 A 1 NA	M5 DA1 Q4
1	2

1. Required model components (choices available on most)
2. Additional options (variety of features and functions that may be added to products)

Specifications and options

See the Specifications and options section for more details on each configuration. Specification and selection of product materials, options, or components must be made by the purchaser of the equipment. See the Material selection section for more information.

Optimizing lead time

The starred offerings (★) represent the most common options and should be selected for best delivery. The non-starred offerings are subject to additional delivery lead time.

Required model components

Model

Code	Description	
248	Temperature transmitter	★

Transmitter type

Code	Description	
D	Wireless field mount	★

Transmitter output

Code	Description	
X	Wireless	★

Product certifications

Code	Description	
NA	No Approval	★
I5	USA Intrinsically Safe and Non-incendive	★
I6	Canada Intrinsically Safe	★
I1	ATEX Intrinsic Safety	★
I7	IECEx Intrinsic Safety	★
I2	INMETRO Intrinsic Safety	★
I4	TIIS Intrinsic Safety	★
I3	NEPSI Intrinsic Safety	★
IM	Technical Regulation Customs Union (EAC), Intrinsic Safety	★

Enclosure

Code	Description	Material	IP rating	
P	Wireless engineered polymer housing	Engineered Polymer	IP66/67	★

Conduit entry size

Code	Description	
2	½-in. NPT	★

Additional options

Assemble to options

Code	Description	
XA ⁽¹⁾	Sensor specified separately and assembled to transmitter	★
NS	No sensor	

(1) When ordering a Rosemount 248 Wireless with the XA option, a mounting bracket is not included. If a bracket is required, order option code B5.

Wireless update rate, operating frequency, and protocol

Code	Description	
WA3	User configurable update rate, 2.4 GHz, WirelessHART®	★

Omnidirectional wireless antenna and SmartPower™

Green power module must be shipped separately, order Model 701PGNKF.

Code	Description	
WP5	Internal antenna, compatible with green power module (I.S. power module sold separately)	★

Mounting bracket

Code	Description	
B5	Universal “L” mounting bracket for 2-in. pipe mounting – SST bracket and bolts	★

Display

Code	Description	
M5	LCD display	★

5-point calibration

Code	Description	
C4	5-point calibration (requires Q4 option code to generate a calibration certificate)	★

Calibration certificate

Code	Description	
Q4	Calibration certificate (3-point calibration)	★

Line filter

Code	Description	
F5	50 Hz line voltage filter	★
F6	60 Hz line voltage filter	★

Software configuration

Code	Description	
C1	Custom configuration of date, descriptor, message, and wireless parameters (requires CDS with order)	★

Extended product warranty

Code	Description	
WR3	3-year limited warranty	★
WR5	5-year limited warranty	★

Specifications

Functional specifications

Input

Supports Thermocouple, RTD, millivolt, and ohm input types. See [Accuracy](#) for a full listing of sensor options.

Output

IEC 62591 (*WirelessHART*[®]) Compliant, 2.4 GHz

Local display

The optional five digit integral LCD display can display sensor temperature in engineering units (°F, °C, °R, K, Ω, and millivolts) and percent of range. The display updates based in the wireless update rate.

Humidity limits

0–99 percent non-condensing relative humidity

Update rate

WirelessHART[®], user-selectable one second to 60 minutes

Accuracy (Pt 100 at reference condition: 20 °C)

±0.81 °F (±0.45 °C)

Wireless radio

Frequency:	2,400–2,485 GHz
Channels:	15
Modulation:	IEEE 802.15.4 compliant

Physical specifications

Material selection

Emerson provides a variety of Rosemount product with various product options and configurations including materials of construction that can be expected to perform well in a wide range of applications. The Rosemount product information presented is intended as a guide for the purchaser to make an appropriate selection for the application. It is the purchaser's sole responsibility to make a careful analysis of all process parameters (such as all chemical components, temperature, pressure, flow rate, abrasives, contaminants, etc.), when specifying product, materials, options and components for the particular application. Emerson is not in a position to evaluate or guarantee the compatibility of the process fluid or other process parameters with the product, options, configuration or materials of construction selected.

Conformance to specifications ($\pm 3\sigma$ [Sigma])

Technology leadership, advanced manufacturing techniques, and statistical process control ensure specification conformance to at least $\pm 3\sigma$.

Electrical connections

Power module

The Emerson SmartPower™ power module is field replaceable, featuring keyed connections that eliminate the risk of incorrect installation.

The power module is an Intrinsically Safe solution, containing Lithium-thionyl chloride with a polybutadine terephthalate (PBT) enclosure.

The device has a power module life time rating of 10 years with a one minute update rate at reference conditions. Reference conditions are 70 °F (21 °C), and routing data for three additional network devices.

Note

Continuous exposure to ambient temperature limits –40 °F or 185 °F (–40 °C or 85 °C) may reduce specified life by less than 20 percent.

Sensor terminals

Sensor terminals permanently fixed to terminal block

Field Communicator connections

Communication terminals

HART® interface connections fixed to the power module

Materials of construction

Enclosure

Housing:	PBT/PC with NEMA® 4X and IP66/67
Cover O-ring:	Silicone
Conduit entry:	316 SST

Mounting

Transmitters may be attached directly to the sensor. Mounting brackets also permit remote mounting. See [Dimensional Drawings](#).

Weight

Engineered polymer

Rosemount 248 Wireless without LCD display: 0.99 lb (0.45 kg)

Rosemount 248 Wireless with LCD display: 1.11 lb (0.51 kg)

Enclosure ratings

Type 4X and IP66/67

Performance specifications

Electromagnetic Compatibility (EMC)

Meets all industrial environment requirements of EN61326 and NAMUR NE-21. Maximum deviation < 1 percent span during EMC disturbances.

Transmitter measurement stability

±0.15 percent of output reading or 0.15 °C (whichever is greater) for 12 months

Self calibration

The analog-to-digital measurement circuitry automatically self-calibrates for each temperature update by comparing the dynamic measurement to extremely stable and accurate internal reference elements.

Vibration effect

The Rosemount 248 Wireless in direct mount configuration is tested to the following specifications with no effect on performance per IEC 60770-1, 1999:

Frequency	Acceleration
10–60 Hz	0.21 mm peak displacement
60–2000 Hz	3 g

The Rosemount 248 Wireless in remote mount configuration is tested to the following specifications with no effect on performance per IEC 60770-1, 1999:

Frequency	Acceleration
10–60 Hz	0.15 mm peak displacement
60–500 Hz	2 g

Sensor connections

Figure 2: Sensor Terminal Block

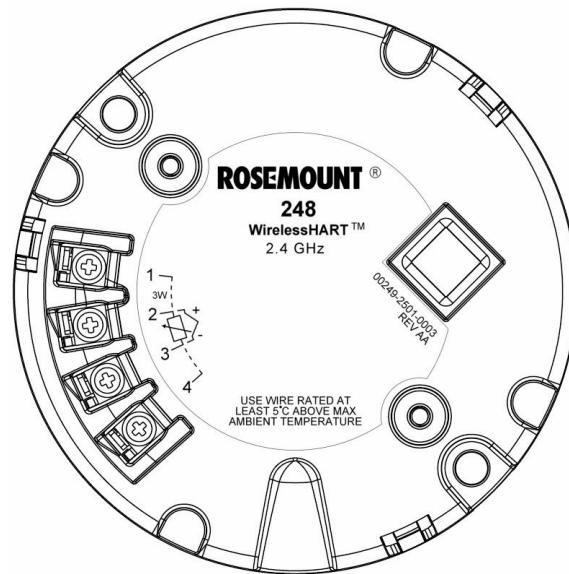

Figure 3: Sensor Connections



2-wire RTD and Ω



3-wire RTD and Ω



4-wire RTD and Ω

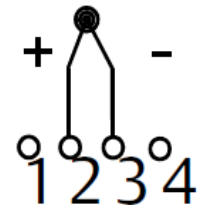

T/C and mV

Note

Emerson provides 4-wire sensors for all single element RTDs. Use these RTDs in 3- or 2-wire configurations by leaving the unneeded leads disconnected and insulated with electrical tape.

Temperature limits

Operating limit	Storage limit
-40 to 185 °F (-40 to 85 °C)	-40 to 185 °F (-40 to 85 °C)

Accuracy

Table 1: Input Options and Accuracy

Sensor options	Sensor reference	Input ranges		Digital accuracy ⁽¹⁾	
		°C	°F	°C	°F
2-, 3-, 4-wire RTDs					
Pt 100 ($\alpha = 0.00385$)	IEC 751	-200 to 850	-328 to 1562	± 0.45	± 0.81
Pt 200 ($\alpha = 0.00385$)	IEC 751	-200 to 850	-328 to 1562	± 0.45	± 0.81
Pt 500 ($\alpha = 0.00385$)	IEC 751	-200 to 850	-328 to 1562	± 0.57	± 1.026

Table 1: Input Options and Accuracy (continued)

Sensor options	Sensor reference	Input ranges		Digital accuracy ⁽¹⁾	
		°C	°F	°C	°F
2-, 3-, 4-wire RTDs					
Pt 1000 ($\alpha = 0.00385$)	IEC 751	-200 to 300	-328 to 572	±0.57	±1.026
Pt 100 ($\alpha = 0.003916$)	JIS 1604	-200 to 645	-328 to 1193	±0.45	±0.81
Pt 200 ($\alpha = 0.003916$)	JIS 1604	-200 to 645	-328 to 1193	±0.45	±0.81
Ni 120	Edison Curve No. 7	-70 to 300	-94 to 572	±0.45	±0.81
Cu 10	Edison Copper Winding No. 15	-50 to 250	-58 to 482	±4.16	±7.488
Pt 50 ($\alpha = 0.00391$)	GOST 6651-94	-200 to 550	-328 to 990	±0.9	±1.62
Pt 100 ($\alpha = 0.00391$)	GOST 6651-94	-200 to 550	-328 to 990	±0.45	±0.81
Cu 50 ($\alpha = 0.00426$)	GOST 6651-94	-50 to 200	-58 to 392	±1.44	±2.592
Cu 50 ($\alpha = 0.00428$)	GOST 6651-94	-185 to 200	-301 to 392	±1.44	±2.592
Cu 100 ($\alpha = 0.00426$)	GOST 6651-94	-50 to 200	-58 to 392	±0.72	±1.296
Cu 100 ($\alpha = 0.00428$)	GOST 6651-94	-185 to 200	-301 to 392	±0.72	±1.296
Thermocouples⁽²⁾					
Type B ⁽³⁾	NIST Monograph 175, IEC 584	100 to 1820	212 to 3308	±2.25	±4.05
Type E	NIST Monograph 175, IEC 584	-50 to 1000	-58 to 1832	±0.60	±1.08
Type J	NIST Monograph 175, IEC 584	-180 to 760	-292 to 1400	±1.05	±1.89
Type K ⁽⁴⁾	NIST Monograph 175, IEC 584	-180 to 1372	-292 to 2501	±1.46	±2.628
Type N	NIST Monograph 175, IEC 584	-200 to 1300	-328 to 2372	±1.46	±2.628
Type R	NIST Monograph 175, IEC 584	0 to 1768	-32 to 3214	±2.25	±4.05
Type S	NIST Monograph 175, IEC 584	0 to 1768	-32 to 3214	±2.1	±3.78
Type T	NIST Monograph 175, IEC 584	-200 to 400	-328 to 752	±1.05	±1.89
DIN Type L	DIN 43710	-200 to 900	-328 to 1652	±1.05	±1.89
DIN Type U	DIN 43710	-200 to 600	-328 to 1112	±1.05	±1.89
Type W5Re/W26Re	ASTM E 988-96	0 to 2000	-32 to 3632	±2.1	±3.78
GOST Type L	GOST R 8.585-2001	-200 to 800	-328 to 1472	±1.80	±3.24
Other sensor types					
Millivolt input		-10 to 100 mV		±0.045 mV	
2-, 3-, 4-wire ohm input		0 to 2000 ohms		±1.35 ohm	

(1) The published digital accuracy applies over the entire sensor input range. Digital output can be accessed by HART® Communications or wireless protocol.

(2) Total digital accuracy for thermocouple measurement: sum of digital accuracy +0.8 °C (cold junction accuracy).

(3) Digital accuracy for NIST Type B T/C is ±16.2 °F (± 9.0 °C) from 212 to 572 °F (100 to 300 °C).

(4) Digital accuracy for NIST Type K T/C is ± 35.79 °F (± 2.1 °C) from -292 to -130 °F (-180 to -90 °C).

Ambient temperature effect

Sensor options	Sensor reference	Input range (°C)	Temperature effects per 1.0 °C (1.8 °F) change in ambient temperature ^{(1) (2)}	Range
2-, 3-, 4-wire RTDs				
Pt 100 ($\alpha = 0.00385$)	IEC 751	-200 to 850	0.009 °C (0.0162 °F)	Entire sensor input range
Pt 200 ($\alpha = 0.00385$)	IEC 751	-200 to 850	0.012 °C (0.0216 °F)	Entire sensor input range
Pt 500 ($\alpha = 0.00385$)	IEC 751	-200 to 850	0.009 °C (0.0162 °F)	Entire sensor input range
Pt 1000 ($\alpha = 0.00385$)	IEC 751	-200 to 300	0.009 °C (0.0162 °F)	Entire sensor input range
Pt 100 ($\alpha = 0.003916$)	JIS 1604	-200 to 645	0.009 °C (0.0162 °F)	Entire sensor input range
Pt 200 ($\alpha = 0.003916$)	JIS 1604	-200 to 645	0.012 °C (0.0216 °F)	Entire sensor input range
Ni 120	Edison Curve No. 7	-70 to 300	0.009 °C (0.0162 °F)	Entire sensor input range
Cu 10	Edison Copper Winding No. 15	-50 to 250	0.06 °C (0.162 °F)	Entire sensor input range
Pt 50 ($\alpha = 0.003910$)	GOST 6651-94	-200 to 550	0.018 °C (0.0324 °F)	Entire sensor input range
Pt 100 ($\alpha = 0.003910$)	GOST 6651-94	-200 to 550	0.009 °C (0.0162 °F)	Entire sensor input range
Cu 50 ($\alpha = 0.00426$)	GOST 6651-94	-50 to 200	0.012 °C (0.0216 °F)	Entire sensor input range
Cu 50 ($\alpha = 0.00428$)	GOST 6651-94	-185 to 200	0.012 °C (0.0216 °F)	Entire sensor input range
Cu 100 ($\alpha = 0.00426$)	GOST 6651-94	-50 to 200	0.009 °C (0.0162 °F)	Entire sensor input range
Cu 100 ($\alpha = 0.00428$)	GOST 6651-94	-185 to 200	0.009 °C (0.0162 °F)	Entire sensor input range
Thermocouples				
Type B	NIST Monograph 175, IEC 584	100 to 1820	0.0435 °C	$T \geq 1000$ °C
			0.096 °C - (0.0075% of [T - 300])	300 °C $\leq T < 1000$ °C
			0.162 °C - (0.033% of [T - 100])	100 °C $\leq T < 300$ °C
Type E	NIST Monograph 175, IEC 584	-50 to 1000	0.015 °C + (0.00129% of absolute value T)	All
Type J	NIST Monograph 175, IEC 584	-180 to 760	0.0162 °C + (0.00087% of T)	$T \geq 0$ °C
			0.0162 °C + (0.0075% of absolute value T)	$T < 0$ °C
Type K	NIST Monograph 175, IEC 584	-180 to 1372	0.0183 °C + (0.0027% of T)	$T \geq 0$ °C

Sensor options	Sensor reference	Input range (°C)	Temperature effects per 1.0 °C (1.8 °F) change in ambient temperature ^{(1) (2)}	Range
			0.0183 °C + (0.0075% of absolute value T)	T < 0 °C
Type N	NIST Monograph 175, IEC 584	-200 to 1300	0.0204 °C + (0.00108% of absolute value T)	All
Type R	NIST Monograph 175, IEC 584	0 to 1768	0.048 °C	T ≥ 200 °C
			0.069 °C – (0.0108% of T)	T < 200 °C
Type S	NIST Monograph 175, IEC 584	0 to 1768	0.048 °C	T ≥ 200 °C
			0.069 °C – (0.0108% of T)	T < 200 °C
Type T	NIST Monograph 175, IEC 584	-200 to 400	0.0192 °C	T ≥ 0 °C
			0.0192 °C + (0.0129% of absolute value T)	T < 0 °C
DIN Type L	DIN 43710	-200 to 900	0.0162 °C + (0.00087% of T)	T ≥ 0 °C
			0.0162 °C + (0.0075% of absolute value T)	T < 0 °C
DIN Type U	DIN 43710	-200 to 900	0.0192 °C	T ≥ 0 °C
			0.0192 °C + (0.0129% of absolute value T)	T < 0 °C
Type W5Re/W26Re	ASTM E 988-96	0 to 2000	0.048 °C	T ≥ 200 °C
			0.069 °C – (0.0108% of T)	T < 200 °C
GOST Type L	GOST R 8.585-2001	-200 to 800	0.021 °C	T ≥ 0 °C
			0.0105 °C + (0.0045% of absolute value T)	T < 0 °C
Other sensor types				
Millivolt input		-10 to 100 mV	0.0015 mV	Entire sensor input range
2-, 3-, 4-wire ohm		0 to 2000 W	0.0252 W	Entire sensor input range

(1) Change in ambient is with reference to the calibration temperature of the transmitter 68 °F (20 °C) from factory.

(2) Ambient temperature effect specification valid over minimum temperature span of 50 °F (28 °C).

Transmitters can be installed in locations where the ambient temperature is between -40 and 185 °F (-40 and 85 °C). In order to maintain excellent accuracy performance, each transmitter is individually characterized over this ambient temperature range at the factory.

Temperature effects example

When using a Pt 100 (α = 0.00385) sensor input at 30 °C ambient temperature:

- Digital temperature effects: 0.009 °C × (30 – 20) = 0.09 °C
- Worst case error: Digital + Digital temperature effects = 0.45 °C + 0.09 °C = 0.54 °C
- Total probable error: $\sqrt{0.45^2 + 0.09^2} = 0.459 \text{ °C}$

Product certifications

Rev 1.11

European Directive Information

A copy of the EU Declaration of Conformity can be found at the end of the Quick Start Guide. The most recent revision of the EU Declaration of Conformity can be found at [Emerson.com/Rosemount](https://www.emerson.com/Rosemount).

Ordinary Location Certification

As standard, the transmitter has been examined and tested to determine that the design meets the basic electrical, mechanical, and fire protection requirements by a nationally recognized test laboratory (NRTL) as accredited by the Federal Occupational Safety and Health Administration (OSHA).

Telecommunication compliance

All wireless devices require certification to ensure that they adhere to regulations regarding the use of the RF spectrum. Nearly every country requires this type of product certification. Emerson is working with governmental agencies around the world to supply fully compliant products and remove the risk of violating country directives or laws governing wireless device usage.

FCC and IC

This device complies with Part 15 of the FCC Rules. Operation is subject to the following conditions: This device may not cause harmful interference. This device must accept any interference received, including interference that may cause undesired operation. This device must be installed to ensure a minimum antenna separation distance of 20 cm from all persons.

North America

The US National Electrical Code® (NEC) and the Canadian Electrical Code (CEC) permit the use of Division marked equipment in Zones and Zone marked equipment in Divisions. The markings must be suitable for the area classification, gas, and temperature class. This information is clearly defined in the respective codes.

USA

I5 USA Intrinsically Safe

Certificate 70008071

Standards FM 3600: 2011; FM 3610: 2010; FM 3611: 2004; UL 61010-1: 2012; UL 50E: 2012; ANSI/IEC 60529:2004

Markings Intrinsically Safe: CL I, DIV 1, GP A, B, C, D; CL I, DIV 2, GP A, B, C, D; Class I, Zone 0, AEx ia IIC T4/T5 Ga; T4 (-50 °C ≤ T_a ≤ +70 °C); T5 (-50 °C ≤ T_a ≤ +40 °C); WHEN INSTALLED PER ROSEMOUNT DWG 00249-2020; TYPE 4X, IP66/67

See [Table 2](#) for entity parameters.

Special Condition for Safe Use (X)

Battery exchange: The battery module can be changed inside hazardous gas-explosive locations. During battery change it must be assured that the connections are free from dust or dirt.

Canada**I6 Canada Intrinsically Safe**

Certificate 70008071

Standards CSA C22.2 No. 0-10; CSA C22.2 No. 94.2-07 (R2012); CSA C22.2 No. 213-M1987 (R2013); CAN/CSA-60079-0-11; CAN/CSA-60079-11-14; CAN/CSA C22.2 No. 60529-05; CAN/CSA-C22.2 No. 61010-1-12

Markings Intrinsically Safe: CL I, DIV 1, GP A, B, C, D; CL I, DIV 2, GP A, B, C, D; Ex ia IIC T4/T5 Ga; T4 ($-50^{\circ}\text{C} \leq T_a \leq +70^{\circ}\text{C}$); T5 ($-50^{\circ}\text{C} \leq T_a \leq +40^{\circ}\text{C}$); WHEN INSTALLED PER ROSEMOUNT DWG 00249-2020; TYPE 4X, IP66/67

See [Table 2](#) for entity parameters.

Special Condition for Safe Use (X)

Battery exchange: The battery module can be changed inside hazardous gas-explosive locations. During battery change it must be assured that the connections are free from dust or dirt.

Europe**I1 ATEX Intrinsic Safety**

Certificate Baseefa14ATEX0359X

Standards EN IEC 60079-0: 2018; EN 60079-11: 2012

Markings  II 1 G Ex ia IIC T4/T5 Ga; T4 ($-60^{\circ}\text{C} \leq T_a \leq +70^{\circ}\text{C}$); T5 ($-60^{\circ}\text{C} \leq T_a \leq +40^{\circ}\text{C}$)

See [Table 2](#) for entity parameters.

Special Condition for Safe Use (X)

The plastic enclosure may present a potential electrostatic ignition hazard and must not be rubbed or cleaned with a dry cloth.

International**I7 IECEx Intrinsic Safety**

Certificate IECEx BAS 14.0158X

Standards IEC 60079-0: 2017; IEC 60079-11: 2011

Markings Ex ia IIC T4/T5 Ga; T4 ($-60^{\circ}\text{C} \leq T_a \leq +70^{\circ}\text{C}$); T5 ($-60^{\circ}\text{C} \leq T_a \leq +40^{\circ}\text{C}$)

See [Table 2](#) for entity parameters.

Special Condition for Safe Use (X)

The plastic enclosure may present a potential electrostatic ignition hazard and must not be rubbed or cleaned with a dry cloth.

Brazil

I2 INMETRO Intrinsic Safety

Certificate	UL-BR 15.0222X
Standards	ABNT NBR IEC 60079-0: 2008 + Corrigendum 1:2011; ABNT NBR IEC 60079-11: 2009
Markings	Ex ia IIC T4/T5 Ga; T4 ($-60\text{ °C} \leq T_a \leq +70\text{ °C}$); T5 ($-60\text{ °C} \leq T_a \leq +40\text{ °C}$) See Table 2 for entity parameters.

Special Condition for Safe Use (X)

The plastic enclosure may present a potential electrostatic ignition hazard and must not be rubbed or cleaned with a dry cloth.

China

I3 NEPSI Intrinsic Safety

Certificate	GYJ20.1147X
Standards	GB3836.1-2010, GB3836.4-2010, GB3836.20-2010
Markings	Ex ia IIC T4/T5 Ga; T4 ($-60\text{ °C} \leq T_a \leq +70\text{ °C}$); T5 ($-60\text{ °C} \leq T_a \leq +40\text{ °C}$) See Table 2 for entity parameters.

Special Conditions for Safe Use (X)

1. Non-metallic parts incorporated in the enclosure of the product shall only be cleaned with a damp cloth to avoid electrostatic charge.
2. Must use Rosemount Model 701PGNKF SmartPower Green Power Module provided by the manufacture.

Japan

I4 TIIS Intrinsic Safety

Certificate	CML 20JPN2243X
Markings	Ex ia IIC T4, T5 Ga ($-60\text{ °C} \sim +40/70\text{ °C}$) See Table 2 for entity parameters.

Special Conditions for Safe Use (X):

1. The plastic enclosure may present a potential electrostatic ignition hazard and must not be rubbed or cleaned with a dry cloth.
2. Power shall be provided only by a Model 701PGNKF SmartPower Green Power Module.

EAC

IM Technical Regulation Customs Union (EAC) Intrinsic Safety

Certificate TC RU C-US.AA87.B.00057

Markings 0Ex ia IIC T4,T5 Ga X, T5(-60 °C ≤ T_a ≤ +40 °C), T4(-60 °C ≤ T_a ≤ +70 °C); IP66/IP67

Specific Condition for Safe Use (X)

See certificate for special conditions.

Table 2: Entity Parameters

Voltage U ₀	6.6 V
Current I ₀	26.2 mA
Power P ₀	42.6 mW
Capacitance C ₀	11 μF
Inductance L ₀	25 mH

Dimensional Drawings

Figure 4: Remote Mount

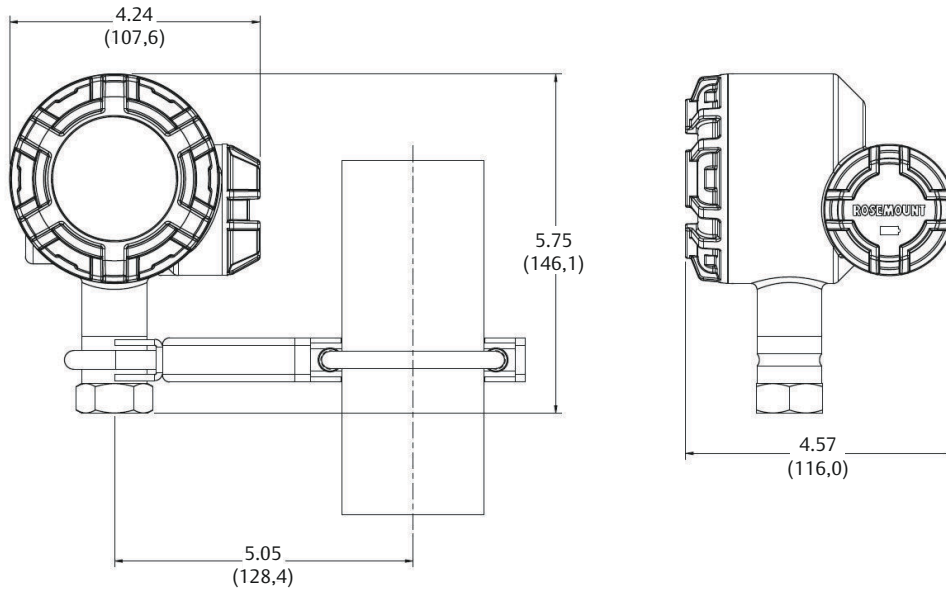

Dimensions are in inches (millimeters).

Figure 5: Direct Mount

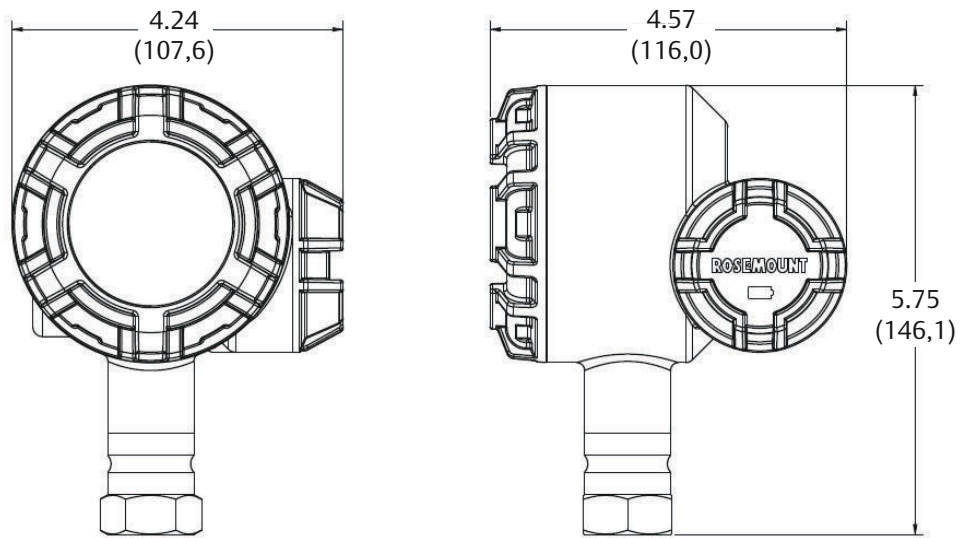

Dimensions are in inches (millimeters).

Emerson Automation Solutions

6021 Innovation Blvd.
Shakopee, MN 55379, USA
📞 +1 800 999 9307 or +1 952 906 8888
📠 +1 952 949 7001
✉️ RFQ.RMD-RCC@Emerson.com

North America Regional Office

Emerson Automation Solutions
8200 Market Blvd.
Chanhassen, MN 55317, USA
📞 +1 800 999 9307 or +1 952 906 8888
📠 +1 952 949 7001
✉️ RMT-NA.RCCRFQ@Emerson.com

Latin America Regional Office

Emerson Automation Solutions
1300 Concord Terrace, Suite 400
Sunrise, FL 33323, USA
📞 +1 954 846 5030
📠 +1 954 846 5121
✉️ RFQ.RMD-RCC@Emerson.com

Europe Regional Office

Emerson Automation Solutions Europe
GmbH
Neuhofstrasse 19a P.O. Box 1046
CH 6340 Baar
Switzerland
📞 +41 (0) 41 768 6111
📠 +41 (0) 41 768 6300
✉️ RFQ.RMD-RCC@Emerson.com

Asia Pacific Regional Office

Emerson Automation Solutions
1 Pandan Crescent
Singapore 128461
📞 +65 6777 8211
📠 +65 6777 0947
✉️ Enquiries@AP.Emerson.com

Middle East and Africa Regional Office

Emerson Automation Solutions
Emerson FZE P.O. Box 17033
Jebel Ali Free Zone - South 2
Dubai, United Arab Emirates
📞 +971 4 8118100
📠 +971 4 8865465
✉️ RFQ.RMTMEA@Emerson.com

 [Linkedin.com/company/Emerson-Automation-Solutions](https://www.linkedin.com/company/Emerson-Automation-Solutions)

 [Twitter.com/Rosemount_News](https://twitter.com/Rosemount_News)

 [Facebook.com/Rosemount](https://www.facebook.com/Rosemount)

 [Youtube.com/user/RosemountMeasurement](https://www.youtube.com/user/RosemountMeasurement)

©2021 Emerson. All rights reserved.

Emerson Terms and Conditions of Sale are available upon request. The Emerson logo is a trademark and service mark of Emerson Electric Co. Rosemount is a mark of one of the Emerson family of companies. All other marks are the property of their respective owners.