

Rosemount™ 2130 Level Switch

Vibrating Fork



Rosemount™ 2130 Level Switch Vibrating Fork

NOTICE

Read this manual before working with the product. For personal and system safety, and for optimum product performance, make sure you thoroughly understand the contents before installing, using, or maintaining this product.

For technical assistance, contacts are listed below:

Customer Central

Technical support, quoting, and order-related questions.

Americas 1 800 999 9307

Europe +41 (0) 41 768 6111

Middle east +971 4 811 8100

Asia +65 6777 8211

North American Response Center

Equipment service needs.

1-800-654-7768 (24 hours — includes Canada)

Outside of these areas, contact your local Emerson™ representative.

⚠ CAUTION

The products described in this document are NOT designed for nuclear-qualified applications.

Using non-nuclear qualified products in applications that require nuclear-qualified hardware or products may cause inaccurate readings.

For information on Rosemount nuclear-qualified products, contact your local Emerson sales representative.

▲ WARNING

Failure to follow these installation guidelines could result in death or serious injury.

- Make sure only qualified personnel perform the installation.
- Use the Rosemount 2130 Level Switch (“level switch”) only as specified in this manual. Failure to do so may impair the protection provided by the equipment.
- The weight of the level switch with a heavy flange and extended fork length may exceed 37 lb. (18 kg). A risk assessment is required to be done before carrying, lifting, and installing the level switch.

Explosions could result in death or serious injury.

- Do not remove the level switch cover in explosive atmospheres when the circuit is alive.
- The level switch cover must be fully engaged and locked to meet explosion-proof requirements.
- Verify the operating environment of the level switch is consistent with the appropriate hazardous locations certifications.
- Review [Appendix B: Product Certifications](#) for special conditions and safety instructions associated with a hazardous location installation.

Electrical shock can result in death or serious injury.

- If the level switch is installed in a high-voltage environment and a fault or installation error occurs, high voltage may be present on the sensor leads and terminals.
- Use extreme caution when making contact with the leads and terminals.
- Make sure the main power to the level switch is off and the lines to any other external power source are disconnected or not powered while wiring the level switch.
- Ensure the wiring is suitable for the electrical current and the insulation is suitable for the voltage, temperature, and environment.

External surfaces may be hot.

- Care must be taken to avoid possible burns. The flange and process seal may also be hot at high process temperatures. Allow to cool before servicing.

Process leaks could result in death or serious injury.

- Install and tighten process connection before applying pressure.
- Do not attempt to loosen the process connection while the level switch is in service.
- Make sure that the level switch is handled carefully. If the process seal is damaged, gas might escape from the tank.

Any substitution of non-recognized parts may jeopardize safety and is under no circumstances allowed.

- Unauthorized changes to the product are strictly prohibited as they may unintentionally and unpredictably alter performance and jeopardize safety.
- Unauthorized changes that interfere with the integrity of the welds or flanges, such as making additional perforations, compromise product integrity and safety. Equipment ratings and certifications are no longer valid on any products that have been damaged or modified without the prior written permission of Emerson. Any continued use of product that has been damaged or modified without the written authorization is at the customer’s sole risk and expense.

Contents

Section 1: Introduction

1.1 Using this manual	1
1.1.1 The sections in this manual.....	1
1.1.2 Definitions and abbreviations	1
1.2 Models covered	1
1.3 Level switch overview	1
1.3.1 Features list	1
1.3.2 Measurement principle	4
1.3.3 Short fork technology	4
1.3.4 Special features.....	4
1.4 Product recycling and disposal	5

Section 2: Installation

2.1 Safety messages.....	7
2.2 Considerations before installation	8
2.2.1 Safety considerations	8
2.2.2 Environmental considerations.....	8
2.2.3 Application considerations.....	9
2.2.4 Installation considerations	11
2.2.5 Installation recommendations.....	12
2.2.6 Installation examples.....	15
2.3 Installation procedures.....	16
2.3.1 Mechanical.....	16
2.3.2 Correct fork alignment	17
2.3.3 Tightening the threaded level switch	19
2.3.4 Insulation	19
2.4 Setting the mode switch and switching time delay.....	20
2.5 LED indication.....	21
2.6 Operating mode.....	22
2.7 Electrical installation	23
2.7.1 Direct load switching electronics cassette.....	23
2.7.2 PNP/PLC electronics cassette.....	25
2.7.3 DPCO relay electronics cassette	26
2.7.4 Fault and alarm relays (2 x SPCO) electronics cassette	27
2.7.5 NAMUR electronics cassette	28
2.7.6 8/16 mA electronics cassette.....	29

2.7.7 Fault condition detected (self-check mode only) 30

Section 3: Service and Troubleshooting

3.1 Safety messages 31
3.2 Magnetic test point 32
3.3 Inspection 32
3.4 Maintenance 33
3.5 Spare parts 33
3.6 Troubleshooting 34
3.7 Service support 34
3.8 Replacement and calibration of electronic cassettes 35
 3.8.1 Replacement sequence 35
 3.8.2 Calibration sequence 37

Section A: Reference Data

A.1 Specifications 39
 A.1.1 General 39
 A.1.2 Mechanical 39
 A.1.3 Functional 39
 A.1.4 Performance 40
 A.1.5 Electrical 41
A.2 Dimensional drawings 42
A.3 Ordering information 46
 A.3.1 Spare parts and accessories 49

Section B: Product Certifications

B.1 European directive information 51
B.2 NAMUR approval 51
B.3 Overfill approval 51
B.4 Marine approvals 51
B.5 Drinking water approval 51
B.6 Ordinary location certifications 51
B.7 Safety Integrity Level (SIL) certification 52
B.8 Canadian Registration Number 52
B.9 Hazardous locations certifications 52
 B.9.1 American and Canadian approvals 52
 B.9.2 European approvals 59
 B.9.3 International approvals 59

Section 1 Introduction

1.1 Using this manual

1.1.1 The sections in this manual

The sections in this manual provide information on installing, operating, and maintaining the Rosemount™ 2130 Level Switch – Vibrating Fork. The sections are organized as follows:

- [Section 2: Installation](#) contains mechanical and electrical installation instructions.
- [Section 3: Service and Troubleshooting](#) covers basic maintenance guidelines and troubleshooting techniques for the most common operating problems.
- [Section A: Reference Data](#) supplies reference and specification data as well as ordering information.
- [Section B: Product Certifications](#) contains safety approval information and approval drawings.

1.1.2 Definitions and abbreviations

The following definitions are used in this manual:

Dry ⁽¹⁾	The Rosemount 2130 fork (sensor) is submerged to a depth of less than 0.5 in. (13 mm)
Wet ⁽¹⁾	The Rosemount 2130 fork (sensor) is submerged to a depth of greater than 0.5 in. (13 mm)
Fault	The fork frequency is outside the normal frequency band
Normal mode	The operating mode in which the Rosemount 2130 considers a 0 Hz fork frequency to represent a wet condition (and not a fault)
Enhanced mode	The operating mode in which the Rosemount 2130 considers a 0 Hz fork frequency to represent a fault condition

1. The switching point does vary with different liquid densities (see [Figure 2-3 on page 10](#)).

1.2 Models covered

All models of the Rosemount 2130 Level Switch -- Vibrating Fork are covered in this manual.

1.3 Level switch overview

1.3.1 Features list

- The Rosemount 2130, version with 2130***E in the model number, is designed for operating in high process temperatures of –94 to 500 °F (–70 to 260 °C)
- Rosemount 2130, version with 2130***M in the model number, is designed for operating in mid-range process temperatures of –40 to 356 °F (–40 to 180 °C)
- Based on vibrating short fork technology, the level switch is suitable for many liquid applications
- Virtually unaffected by flow, bubbles, turbulence, foam, vibration, solids content, coating products, liquid properties, and product variations

- Electronic self-checking and condition monitoring.
A 'heartbeat' LED indicates its operating state.
The LED also flashes when the switch output is 'off' and is constantly lit when 'on'
- 'Fast drip' fork design gives quicker response time, especially with viscous liquids. Rapid wet-to-dry and dry-to-wet time setting for highly responsive switching
- Adjustable switching delay prevents false switching in turbulent or splashing applications
- Magnetic test-point for easy functional test
- No moving parts or crevices for virtually no maintenance
- No need for calibration and requires minimum installation procedures
- Easy terminal access and electrical protections (see "Electrical" on page 41)
- Short fork length with extensions up to 157.5 in. (4 m)
- General area, explosion-proof/flameproof and intrinsically safe options
- SIL 2 suitable (see "Ordering information" on page 46)

This combination of features makes the Rosemount 2130 Level Switch an ideal choice for a wide variety of challenging applications in the chemical, power generation, and oil and gas industries.

See Figure 1-2 on page 3 for application examples.

Figure 1-1. Rosemount 2130 Features

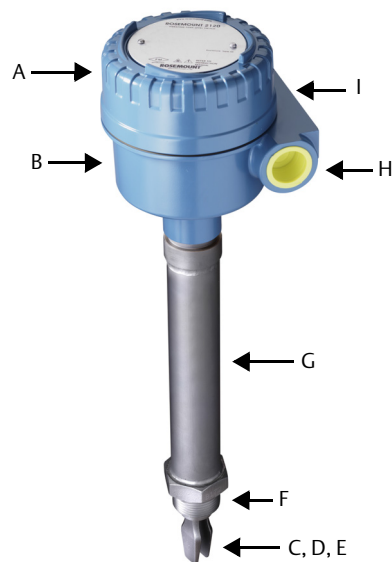

- A. Electronics cassettes: Direct Load, DPCO Relay, Fault + Alarm (2 x SPCO) Relays, PLC/PNP, NAMUR, or 8/16 mA
- B. NEMA® Type 4X (IP66/67) housings in aluminum or 316 stainless steel
- C. Short fork length with extensions up to 157.5 in. (4 m)
- D. Wetted material in 316/316L stainless steel, solid Alloy C and Alloy C-276, or ECTFE co-polymer coated 316/316L stainless steel
- E. 'Fast drip' fork design
- F. Threaded, flanged, or Tri Clamp connections
- G. Thermal tube in 316/316L stainless steel (2130***E version only)
- H. Two cable/conduit entries
- I. Magnetic test point

Figure 1-2. Rosemount 2130 Application Examples



Overfill protection

Spillage caused by overfilling can be hazardous to people and the environment, resulting in lost product and potentially high clean up costs.

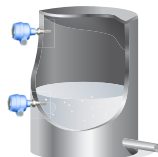

High and low level alarm

Maximum and minimum level detection in tanks containing different types of liquids are ideal applications. The Rosemount 2130 is robust and operates continuously across the process temperature range of -94 to 500 °F (-70 to 260 °C) and operating pressures of up to 1450 psig (100 barg), making it perfect for use as a high or low level alarm. It is common practice to have an independent high level alarm switch as a backup to an installed level device in case of primary failure.

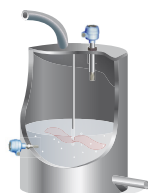

Pump control (limit detection)

Batch processing tanks often contain stirrers and agitators to ensure mixing and product 'fluidity'. The standard user selectable time delay, from 0.3 to 30 seconds, virtually eliminates the risk of false switching from splashing.

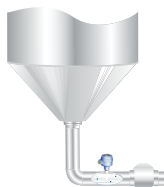

Pump protection or empty pipe detection

With the fork projecting only 2 in. (50 mm) (dependent on connection type), the Rosemount 2130 can be installed in small diameter pipes. Short forks mean minimum intrusion on the wet side and allow for simple, low cost installation at any angle into pipes or tanks. By selecting the option of direct load switching or relay electronics, the Rosemount 2130 is ideal for reliable pump control and can be used to protect against pumps running dry.



High temperature applications

The 2130***E version is designed for high temperatures and is suitable for continuous operation within the process temperature range of -94 to 500 °F (-70 to 260 °C).

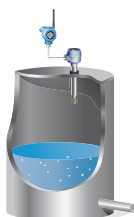

Wireless applications

The advent of wireless communications allows process plant managers to save up to 90% on installation cost compared with wired technologies. More data can be collected at central locations than has ever been possible before. The Rosemount 2130 can be used with a Rosemount 702 Wireless Discrete Transmitter to enable these benefits for your applications.



Hygienic applications

With the highly polished forks option providing a surface finish (Ra) better than 0.4 μm, the Rosemount 2130 meets the most stringent hygienic requirements used in food and beverage, and pharmaceutical applications. It is robust enough to easily withstand CIP (Clean In Place) and SIP (Steam In Place) cleaning routines.

1.3.2 Measurement principle

The level switch is designed using the principle of a tuning fork. A piezo-electric crystal oscillates the forks at their natural frequency. Changes to this frequency are continuously monitored. The frequency of the vibrating fork sensor changes depending on the medium in which it is immersed. The denser the liquid, the lower the frequency.

When used as a **low level alarm**, the liquid in the tank or pipe drains down past the fork, causing a change of natural frequency that is detected by the electronics and switches the output state.

When the level switch is used as a **high level alarm**, the liquid rises in the tank or pipe making contact with the fork and causing the output state to switch.

1.3.3 Short fork technology

The natural frequency (~ 1400 Hz) of the fork avoids interference from plant vibration that may cause false switching. This allows for minimum intrusion into the tank or pipe through the use of a short fork. Using short fork technology, the Rosemount 2130 Level Switch can be used in almost all liquid applications. Extensive research has maximized the operational effectiveness of the fork design, making it suitable for most liquids including coating liquids, aerated liquids, and slurries.

1.3.4 Special features

Instrument health monitor and continuous self-check

The Rosemount 2130 Level Switch continuously performs instrument health diagnostics to self-check the condition of the fork and sensor. These diagnostics can detect damage to the forks including corrosion, internal or external damage to the forks, and breakages to the internal wiring. Any of these conditions will trigger the 'heartbeat' LED to pulse intermittently, followed by safe handling of the electrical load.

Heartbeat LED

The Rosemount 2130 has a 'heartbeat' LED that indicates its operating state. The LED flashes when the switch output is 'off' and is constantly lit when 'on'.

Fork design

The "fast drip" fork design draws liquid away from the fork tips when mounted horizontally, and together with a short switching delay, allows the Rosemount 2130 to react quickly and with greater sensitivity to density variations.

Mode switch and adjustable time delay

A mode switch allows the Rosemount 2130 to be set to switch from wet to dry (typically for low level alarm) or from dry to wet (typically for high level alarm). There is also a user-selectable time delay (0.3, 1, 3, 10, or 30 s) to virtually eliminate the risk of false switching in turbulent or splashing applications.

Magnetic test point

A magnetic test-point is located on the side of the housing, allowing the user to perform a functional test of the Rosemount 2130 and the system connected to it. Holding a magnet to the test-point causes the output to change state.

Electrical hook-up

The terminal blocks extend above the housing and give easy terminal access. Electrical protections make electrical hook-up safe and easy (see "Electrical" on page 41).



1.4 Product recycling and disposal

Recycling of equipment and packaging should be taken into consideration. The product and packaging should be disposed of in accordance with local and national legislation.

Section 2 Installation

Safety messages	page 7
Considerations before installation	page 8
Installation procedures	page 16
Setting the mode switch and switching time delay	page 20
LED indication	page 21
Operating mode	page 22
Electrical installation	page 23

2.1 Safety messages

Procedures and instructions in this manual may require special precautions to ensure the safety of the personnel performing the operations. Information that raises potential safety issues is indicated by a caution symbol () . The external hot surface symbol () is used when a surface is hot and care must be taken to avoid possible burns. If there is a risk of an electrical shock, the () symbol is used. Refer to the safety messages listed at the beginning of each section before performing an operation preceded by this symbol.

WARNING

Failure to follow these installation guidelines could result in death or serious injury.

- Make sure only qualified personnel perform the installation.
- Use the Rosemount 2130 Level Switch (“level switch”) only as specified in this manual. Failure to do so may impair the protection provided by the equipment.
- The weight of the level switch with a heavy flange and extended fork length may exceed 37 lb. (18 kg). A risk assessment is required to be done before carrying, lifting, and installing the level switch.

Explosions could result in death or serious injury.

- Do not remove the level switch cover in explosive atmospheres when the circuit is alive.
- The level switch cover must be fully engaged and locked to meet explosion-proof requirements.
- Verify the operating environment of the level switch is consistent with the appropriate hazardous locations certifications.
- Review [Appendix B: Product Certifications](#) for special conditions and safety instructions associated with a hazardous location installation.

Electrical shock can result in death or serious injury.

- If the level switch is installed in a high-voltage environment and a fault or installation error occurs, high voltage may be present on the sensor leads and terminals.
- Use extreme caution when making contact with the leads and terminals.
- Make sure the main power to the level switch is off and the lines to any other external power source are disconnected or not powered while wiring the level switch.
- Ensure the wiring is suitable for the electrical current and the insulation is suitable for the voltage, temperature, and environment.

⚠ WARNING

External surfaces may be hot.

- Care must be taken to avoid possible burns. The flange and process seal may also be hot at high process temperatures. Allow to cool before servicing.

Process leaks could result in death or serious injury.

- Install and tighten process connection before applying pressure.
- Do not attempt to loosen the process connection while the level switch is in service.
- Make sure that the level switch is handled carefully. If the process seal is damaged, gas might escape from the tank.

2.2 Considerations before installation

Important

Emerson is not in a position to evaluate or guarantee the compatibility of the process fluid or other process parameters with the product, options, configuration or materials of construction selected.

2.2.1 Safety considerations

Safety instructions and control drawings specific to hazardous area installations are in [Appendix B: Product Certifications](#), and there are safety instructions in the Rosemount 2120 [Quick Start Guide](#) (see Emerson.com/Rosemount). The safety instructions also include general safety information.

2.2.2 Environmental considerations

The Rosemount 2130 Level Switch (“level switch”) is available as Intrinsically Safe (IS) or explosion-proof/flameproof versions for hazardous area installations. There are also ordinary location versions for unclassified, safe areas. Approvals are listed in [Appendix B: Product Certifications](#).

This level switch is designed for detecting liquids in open or closed tank, and pipe installations. It is weatherproof and protected against the ingress of dust, but must be protected from flooding. Avoid installing the level switch near heat sources.

Figure 2-1. Environmental Considerations

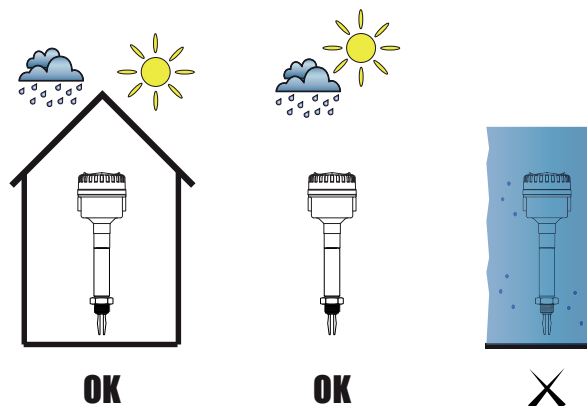

2.2.3 Application considerations

For most liquids, including coating, aerated liquids and slurries, the function is virtually unaffected by flow, turbulence, bubbles, foam, vibration, solid particles, build-up, or properties of the liquid.

The 2130***E version of the level switch operates in high process temperatures of -94 to 500 °F (-70 to 260 °C).

The 2130***M version of the level switch operates in mid-range process temperatures of -40 to 356 °F (-40 to 180 °C).

The level switch can be mounted in an open or closed tank, or pipe. There is a wide range of threaded, flanged, and Tri Clamp process connections.

Important

There should be no risk of ‘bridging’ the forks (see [Figure 2-2](#)). Examples of media that can create ‘bridging’ of forks are dense paper slurries and bitumen.

Figure 2-2. Avoid Product Build-up

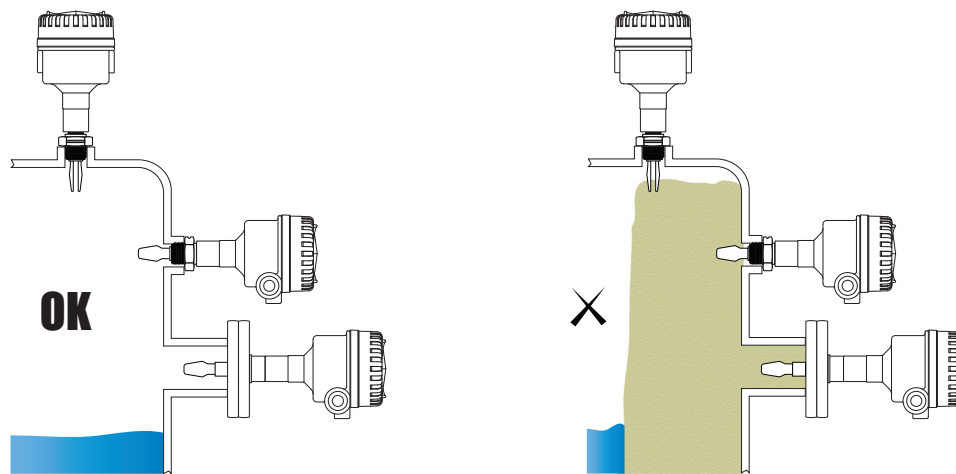

Application guidelines

- Ensure the process is operating within the level switch operating temperature and pressure ranges (see “Specifications” on page 39).
- Ensure the liquid viscosity is within the recommended viscosity range (see “Specifications” on page 39).
- Check that the liquid density is higher than 37.5 lb/ft³ (600 kg/m³), or above 31.2 lb/ft³ (500 kg/m³) when ordered with the Low Density Range option (see “Specifications” on page 39).
- Liquid density affects the switching point e.g. dry-to-wet (see [Figure 2-3](#) on page 10)
- Check for risk of build-up on the forks.
Avoid situations where drying and coating products may create excessive build-up. Problems may occur if the product coats and then dries, causing caking.
- Check the solids content in the liquid.

As a guideline, the maximum solid particle diameter in the liquid is 0.2 in. (5 mm). Extra consideration is needed when dealing with particles bigger than 0.2 in. (5 mm). Consult the factory for advice.

- In almost all cases, the level switch is insensitive to foams (i.e. does not see the foam). However, on rare occasions, some very dense foams may be seen as liquid. Known examples of this are found in ice-cream and orange juice manufacturing.

Figure 2-3. Switching Points

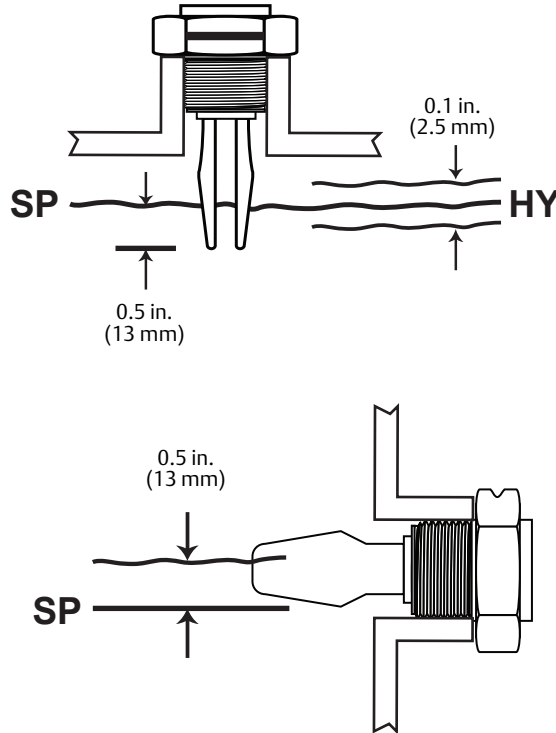

SP. Switchpoint (H₂O)
HY. Switching Hysteresis

Note

When mounted vertically, a low density media has a switching point closer to the process connection. A high density media has a switching point closer to fork tip.

2.2.4 Installation considerations

For dimensional drawings, see “Dimensional drawings” on page 42.

Device identification

To identify the Rosemount 2130 Level Switch version, look at the labels on the housing and on the electronics cassette inside the housing. See “Product Certifications” on page 51 for approval information.

Allow adequate space outside tank or pipe

Mount the level switch so that it is removable. Clearance of 1.2 in. (30 mm) is required for cover removal. Ensure there is sufficient room for electrical connections.

The housing cannot be rotated. Ensure there is sufficient room for electrical connections.

Fit the cover correctly

Ensure that the housing O-ring is sitting evenly and then tighten the housing cover to form a good seal. Always use Emerson O-rings.

Grounding

Always ground the housing in accordance with national and local electrical codes.

The most effective grounding method for the housing is a direct connection to earth ground with minimal impedance. Housings with NPT conduit entries do not have an earth ground point and must use the fork earth.

Do not modify the level switch

Do not change the level switch fork in any way (Figure 2-4).

Figure 2-4. Do Not Modify the Rosemount 2130

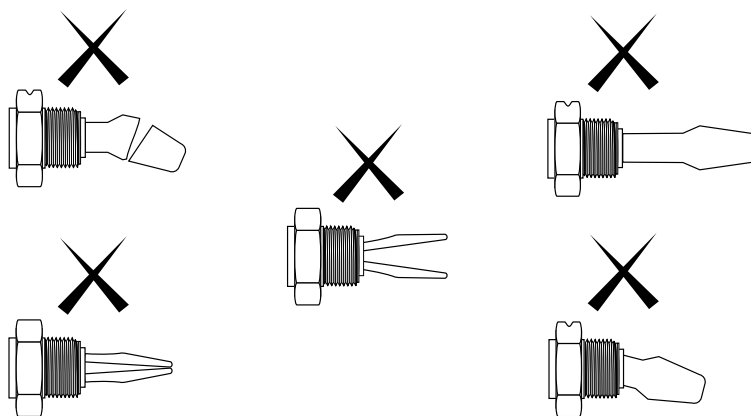

How to handle the level switch

Handle the level switch with great care (Figure 2-5).

The weight of a level switch with a heavy flange and extended fork length may exceed 37 lb. (18 kg). A risk assessment is required to be done before carrying, lifting, and installing the level switch.

Use both hands to carry the high temperature versions (2130***E) and extended length versions (2130***M) of the level switch. Do not hold using the forks.

For hygienic applications, the level switch must be hygienically cleaned before installation and handled in strict accordance with hygienic standards.

Figure 2-5. Handling the Rosemount 2130

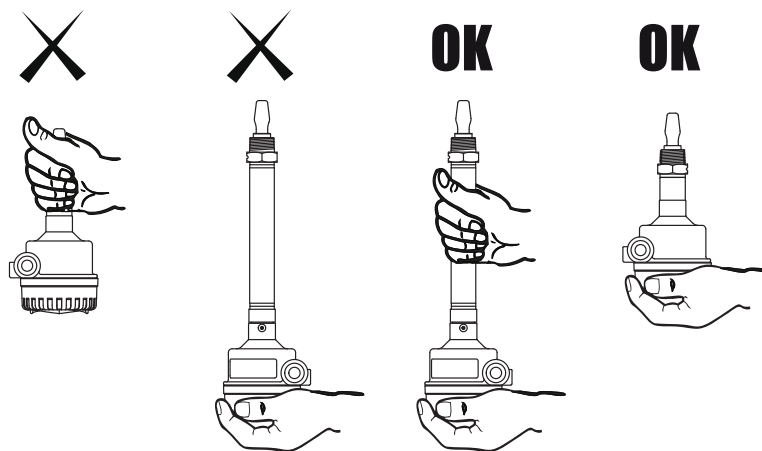

2.2.5

Installation recommendations

- Test the system by using the magnetic test-point (see “Magnetic test point” on page 32).
- Avoid installing near to liquid entering the tank at the fill point.
- Avoid heavy splashing on the forks. Increasing the time delay reduces accidental switching.
- Ensure that the forks do not come into contact with the tank wall, any internal fittings, or obstructions.
- Allow for a sufficient distance between product build-up and fork (see Figure 2-2 on page 9).
- Ensure the installation does not create tank crevices around the forks where liquid may collect. This can happen with high viscosity and high density liquids.
- Extra consideration is needed if the plant vibration is close to the 1400 Hz operating frequency of the level switch.
- Supporting the extended fork avoids long fork length vibration (see Figure 2-6 on page 13 or Figure 2-7 on page 14, depending on installation).

Figure 2-6. Required Supports for Extended Fork (Standard)

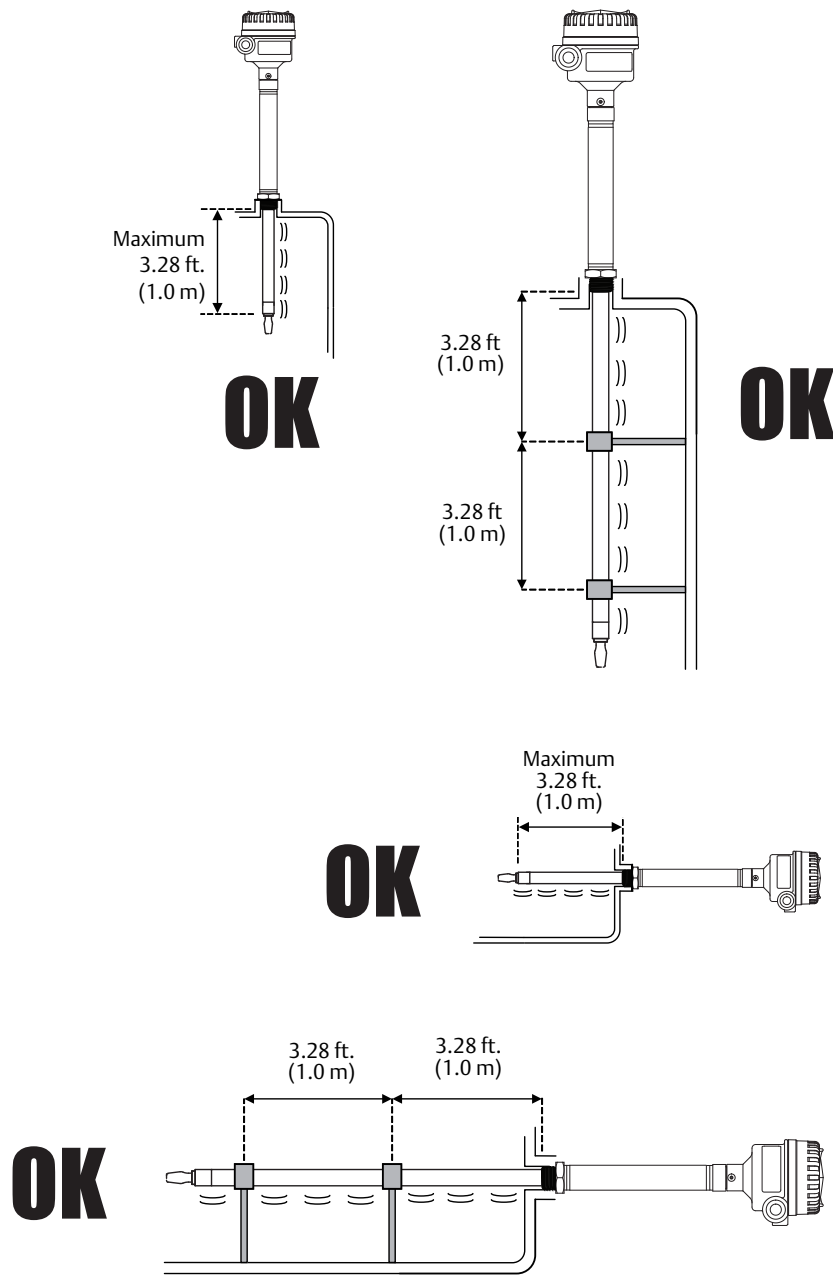
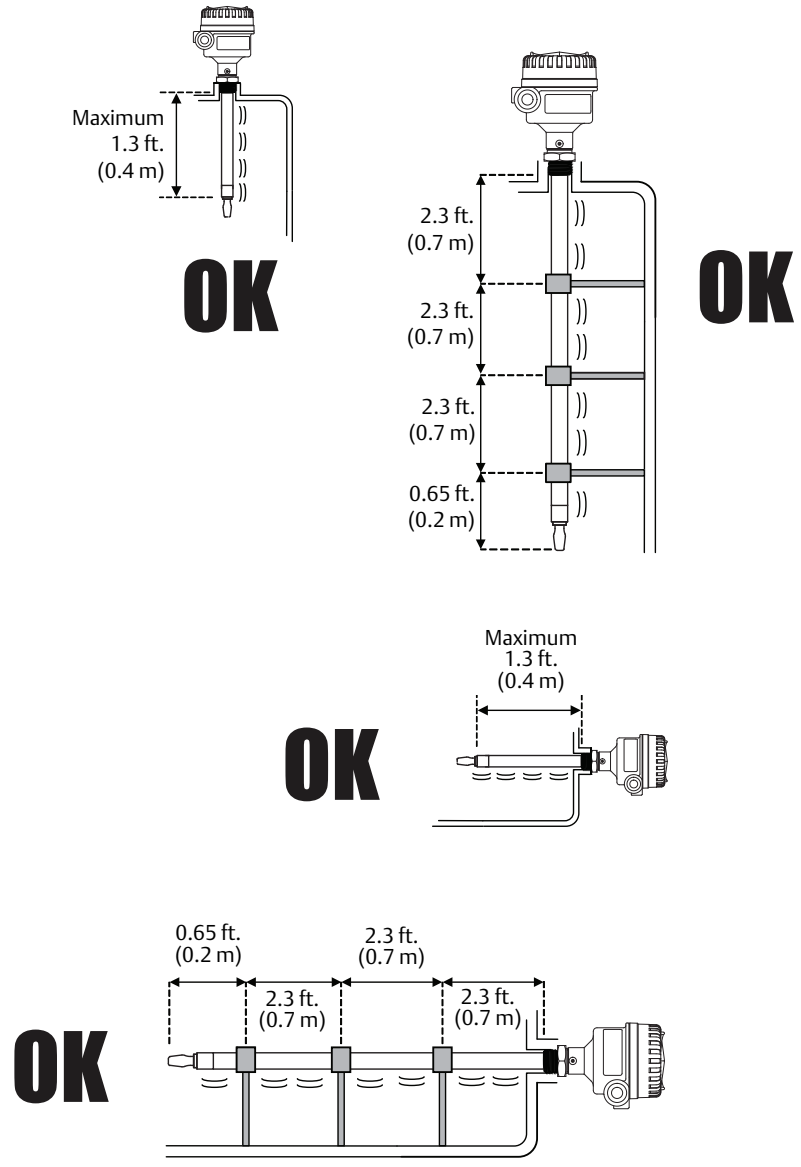
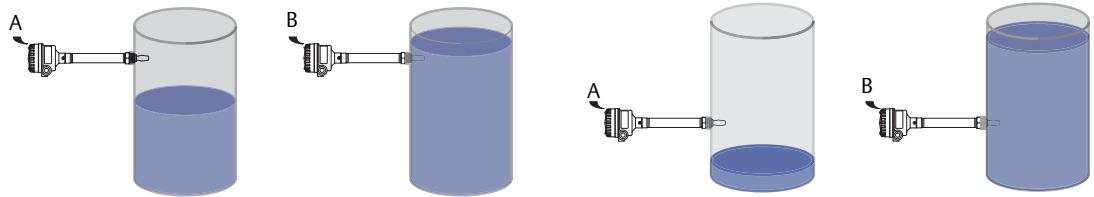

Figure 2-7. Required Supports for Extended Fork (Marine GL Approval)



2.2.6 Installation examples

Figure 2-8. High and Low Level Alarms



A. Dry
B. Wet

Figure 2-9. Pump Control or Overfill Protection

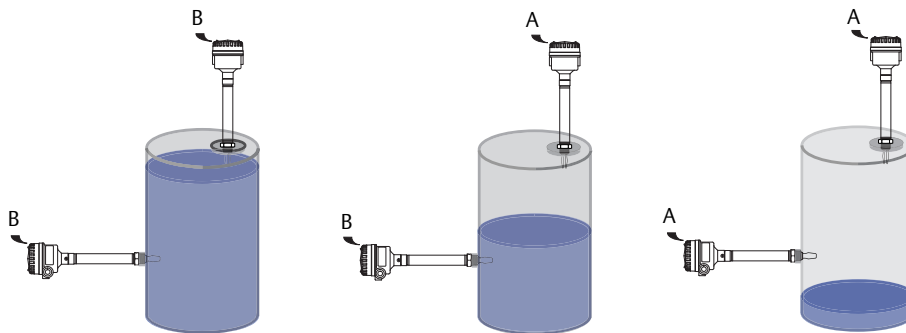

A. Dry
B. Wet

Figure 2-10. Pump or Empty Pipe Protection

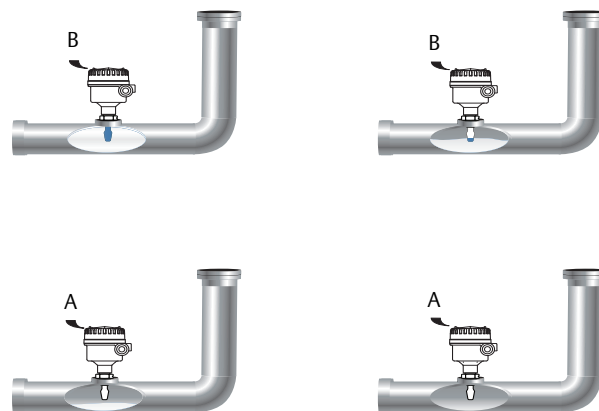

A. Dry
B. Wet

2.3 Installation procedures

2.3.1 Mechanical Sealing

Figure 2-11. Sealing

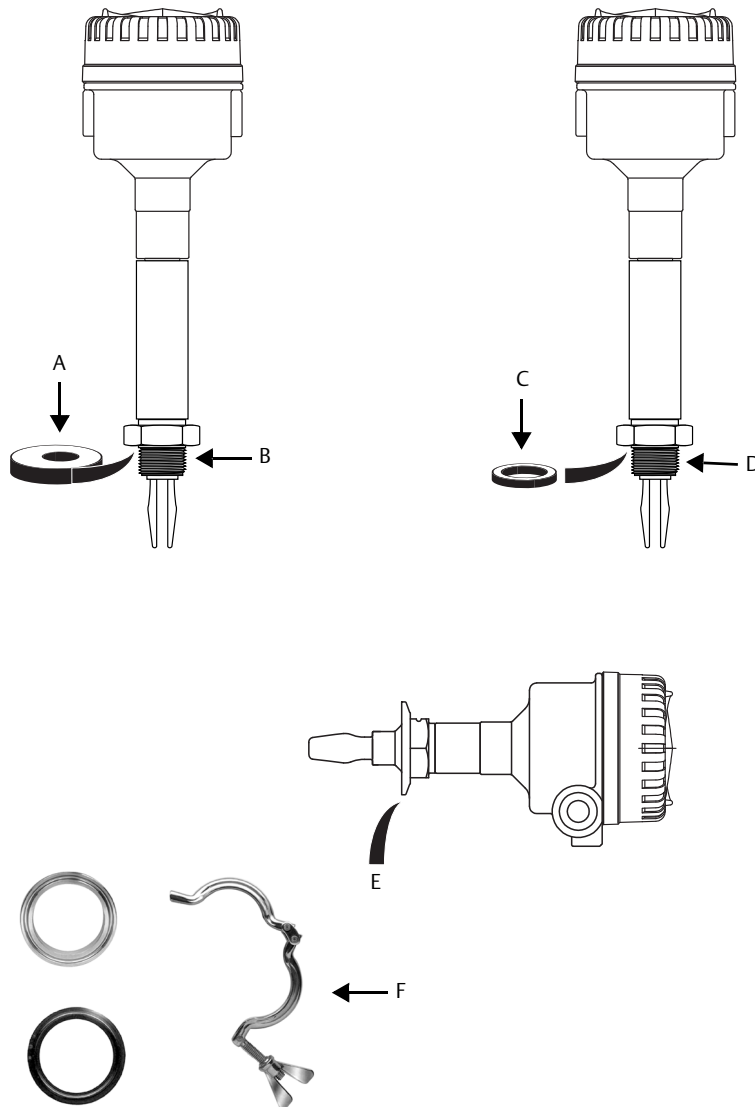

- A. PTFE
- B. NPT or BSPT (R) thread
- C. Gasket
- D. BSPP (G) thread
- E. Tri Clamp
- F. The Tri Clamp seal is supplied as an as accessory kit (see “Spare parts and accessories” on page 49)

2.3.2 Correct fork alignment

Ensure the fork is correctly aligned by using the notches and grooves as indicated in [Figure 2-12](#).

Figure 2-12. Correct Fork Alignment

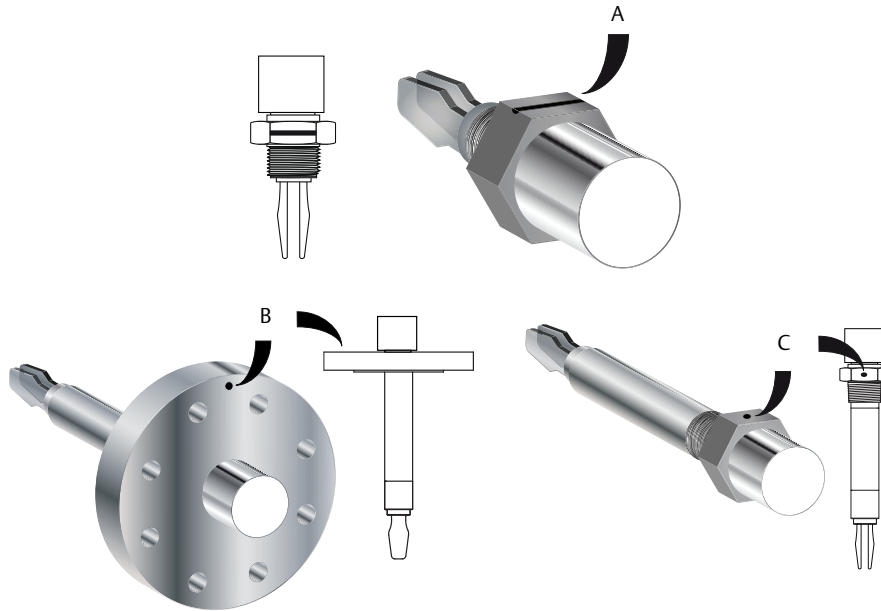

- A. Alignment groove on standard length Rosemount 2130
- B. Alignment notch on flanged Rosemount 2130
- C. Alignment notch on extended length Rosemount 2130

Pipe installation

Figure 2-13. Pipe Installation

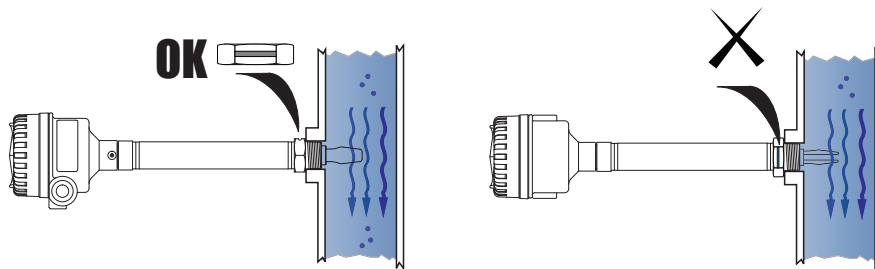

Note
The housing/enclosure cannot be rotated.

Tank installation

Figure 2-14. Tank Installation

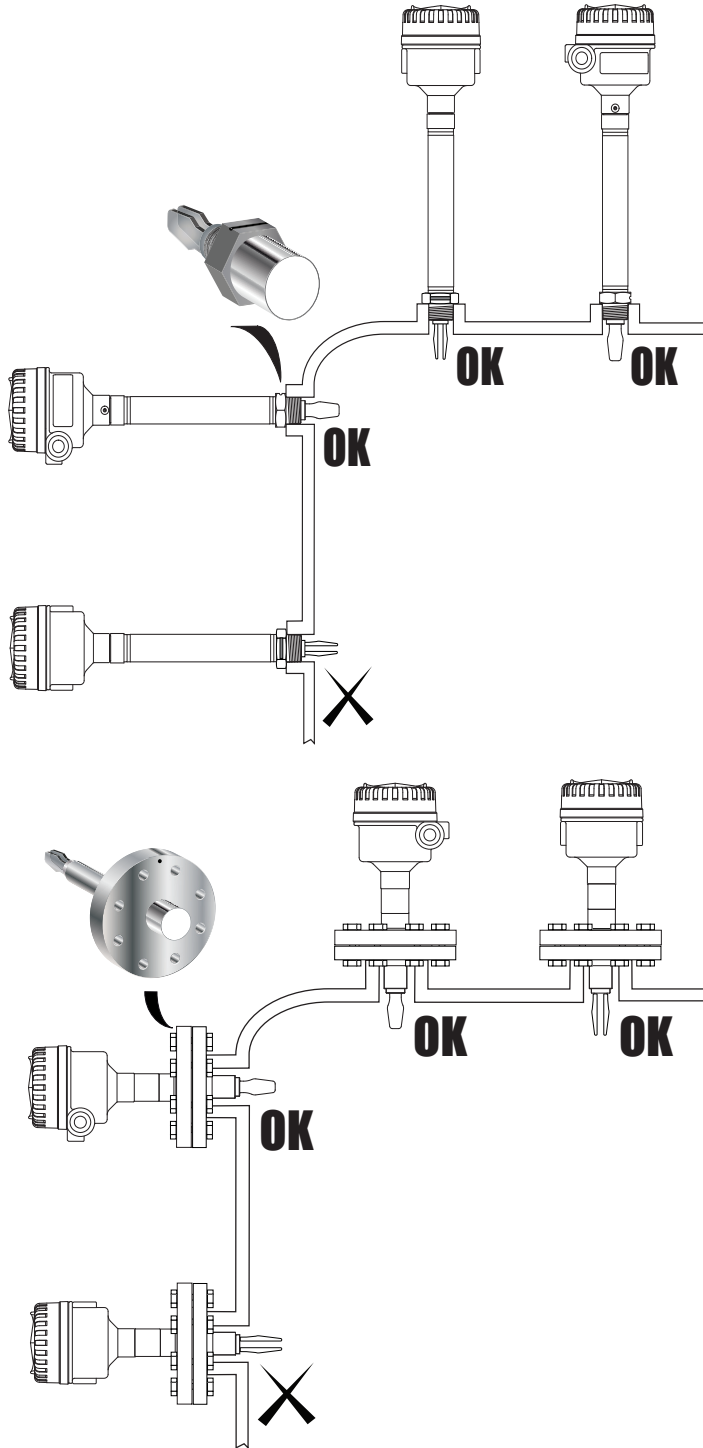

Note
The housing/enclosure cannot be rotated.

2.3.3 Tightening the threaded level switch

Figure 2-15. Tightening the Threaded Rosemount 2130

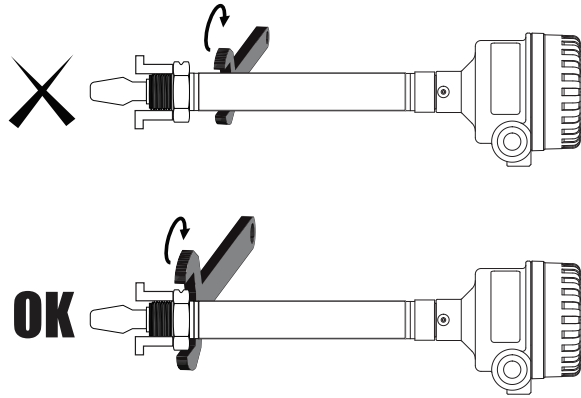

2.3.4 Insulation

Figure 2-16. Insulation

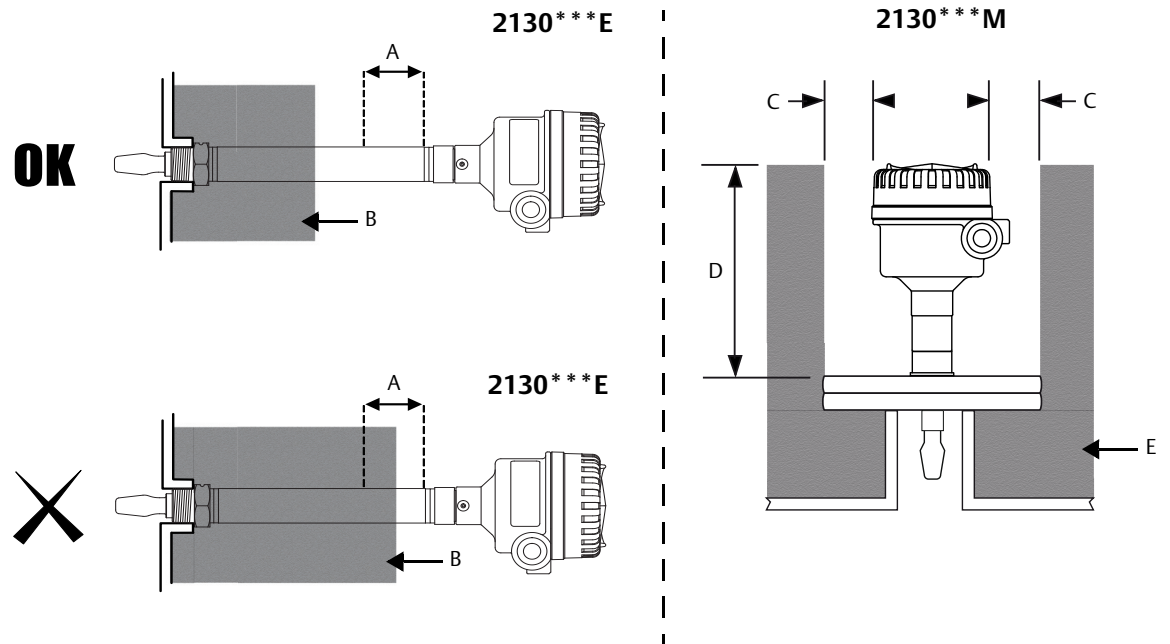

- A. 2.1 in. (55 mm)
- B. ROCKWOOL® surrounds the Rosemount 2130
- C. 3.9 in. (100 mm) clearance all around
- D. 5.9 in. (150 mm)
- E. ROCKWOOL

2.4 Setting the mode switch and switching time delay

1. Select “Dry on” or “Wet on” mode.
2. Select 0.3, 1, 3, 10, or 30 seconds for the delay before switching output state.

Note

There is a five second delay when changing mode or time delay. The small cut-out on the mode switch indicates the selected mode and time delay.

Recommended installation for high level is “Dry on” (Figure 2-18) and for low level it is “Wet on” (Figure 2-19). Do not install in the normally ‘off’ state.

Figure 2-17. Top-down View: Example Cassette Inside Housing

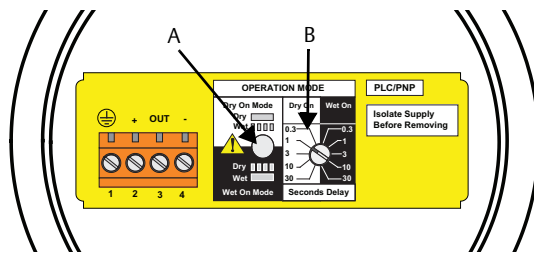

- A. LED
B. Mode switch/time delay

Figure 2-18. “Dry On” Mode, One Second Time Delay (Typical for High Level Applications)

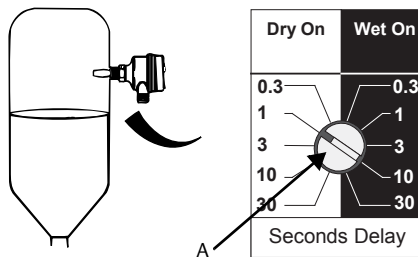

- A. Mode “Dry on” and one second delay

Figure 2-19. “Wet On” Mode, One Second Time Delay (Typical for Low Level Applications)

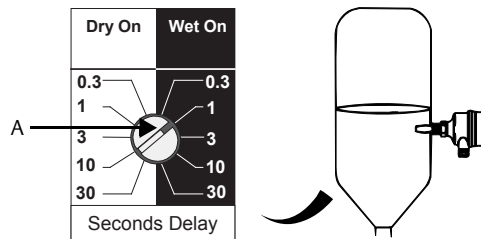

- A. Mode “Wet On” and one second delay









2.5 LED indication

Table 2-1. LED Indication for Operating Modes

LED colors	Operating modes ⁽¹⁾	Description of mode
Red	Normal	When the LED is red and flashing, it indicates the 2130 may be uncalibrated, successfully calibrated, has an electrical load problem, or has an internal PCB fault. See the table below for further information.
Yellow	Self-Check	When the LED is yellow and flashing, it indicates the same as Normal mode, but also indicates there could be external damage to forks, corroded forks, or internal sensor damage. See the table below for further information.

1. See "Operating mode" on page 22.

Table 2-2. LED Indication for Switch Status

LED flash rate	Switch status
 Continuous	Output state is on
 1 every 1/2 second and every third flash is missing	External damage to forks; corroded forks; internal wire damage; internal sensor damage ⁽¹⁾ (Self-Check mode only)
 1 every second	Output state is off
 1 every 2 seconds	Uncalibrated – Refer to "Replacement and calibration of electronic cassettes" on page 35
 1 every 4 seconds	Load fault; load current too high; load short circuit
 2 times every second	Indication of successful calibration
 3 times every second	Internal PCB fault (microprocessor, ROM, or RAM) – Refer to "Product recycling and disposal" on page 5
 Off	Problem (e.g. supply)

1. See "Fault condition detected (self-check mode only)" on page 30.

2.6 Operating mode

Note

For SIL 2 compliance, self-check mode must be enabled.
See also “Safety Integrity Level (SIL) certification option” on page 48.

Selecting self-check operating mode

Figure 2-20. Selecting Self-check Operating Mode

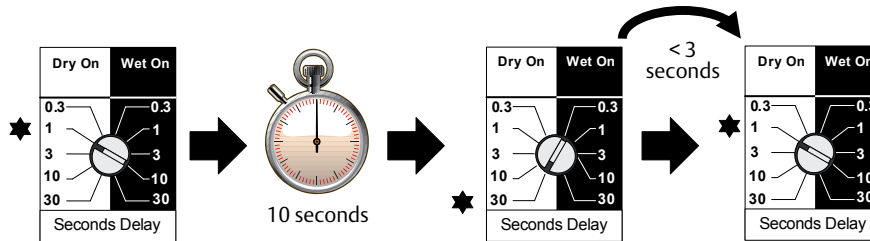

When the self-check mode is operating, the 'heartbeat' LED color is yellow.

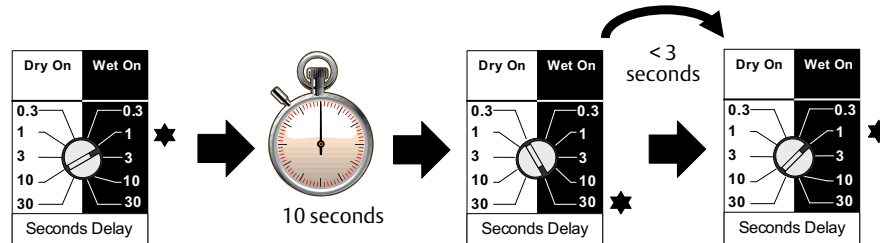

Selecting normal operating mode

Figure 2-21. Selecting Normal Operating Mode



When the normal mode is operating, the 'heartbeat' LED color is red.

2.7 Electrical installation

-  Before use, check that suitable cable glands and blanking plugs are fitted and fully tightened.
-  Isolate supply before connecting the switch or removing the electronics.
-  The Protective Earth (PE) terminal must be connected to an external earthing system.

Note

When replacing a cassette, it is essential to re-calibrate.
Refer to “Replacement and calibration of electronic cassettes” on page 35.

2.7.1 Direct load switching electronics cassette

Figure 2-22. Direct Load Switching (Two-wire, Red Label)

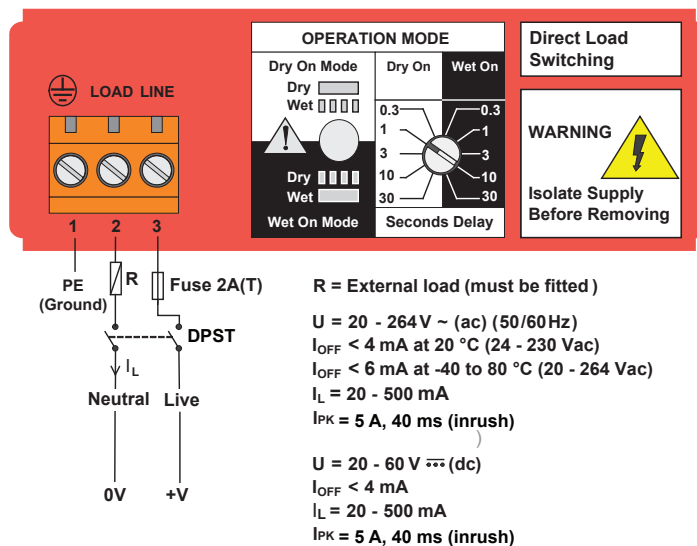

Note

A DPST (Double Pole, Single Throw) on/off switch must be installed to safely disconnect the power supply. Fit the DPST switch as close as possible to the Rosemount 2130. Keep the DPST switch free of obstructions. Label the DPST switch to indicate it is the supply disconnection device for the Rosemount 2130.

Relay Connection Warning

The Rosemount 2130 requires a minimum current to operate (I_{OFF}), which continues to flow when the output is ‘off’. If selecting a relay to wire in series with the Rosemount 2130, ensure the drop-out voltage of the relay is greater than the voltage generated across the relay coil when I_{OFF} flows through it.

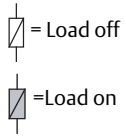
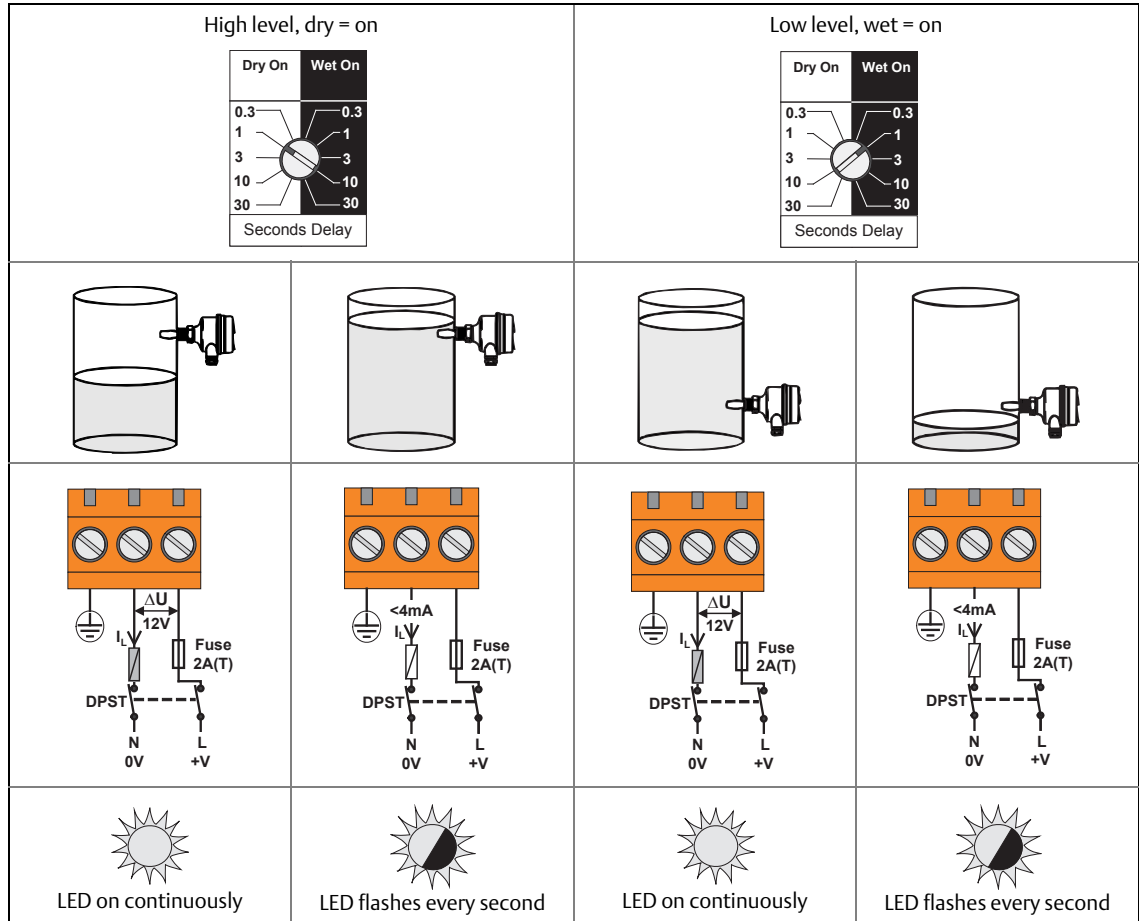

2.7.2 PNP/PLC electronics cassette

Figure 2-23. PNP Output for Load and Direct PLC Switching (Three-wire, Yellow Label)

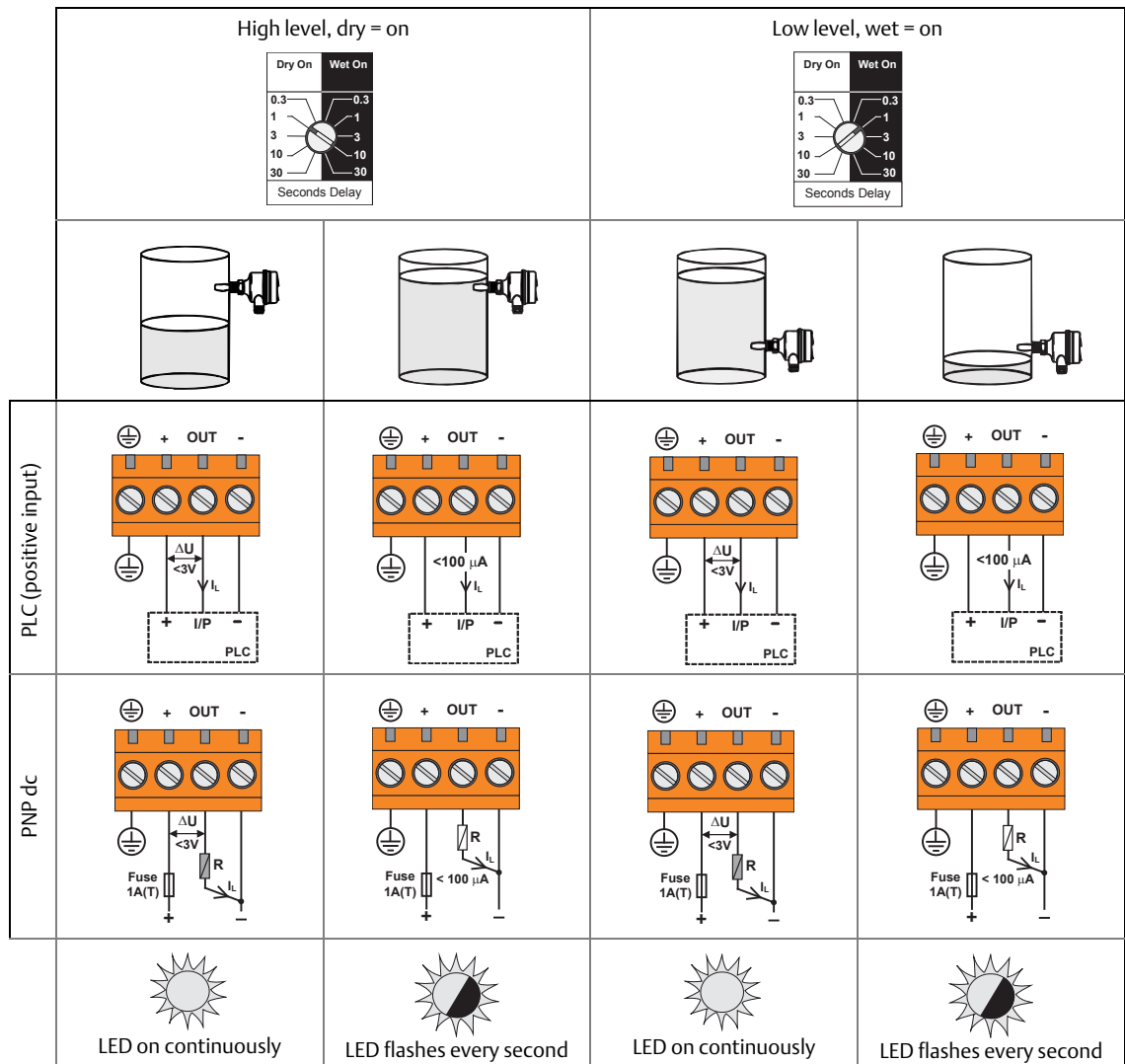
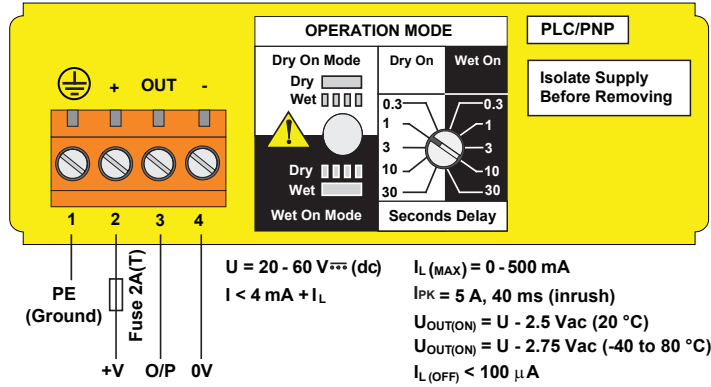

2.7.3 DPCO relay electronics cassette

Figure 2-24. DPCO Relay (Dark Green Label)

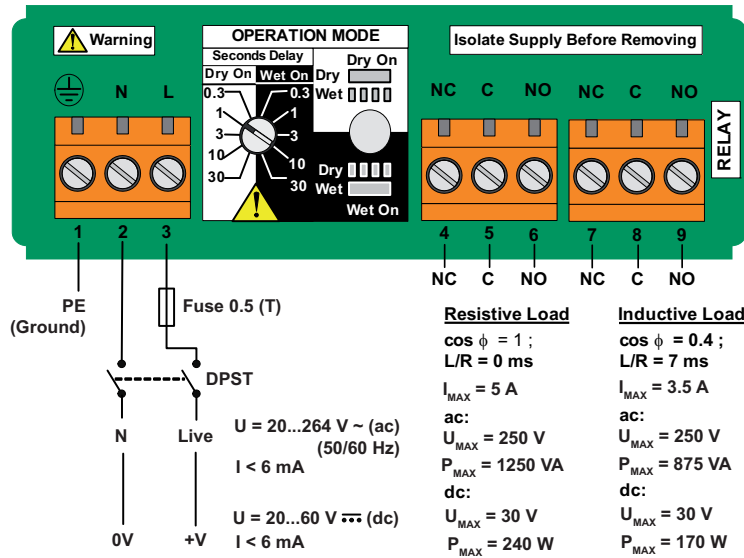

Note

A DPST (Double Pole, Single Throw) on/off switch must be installed to safely disconnect the power supply. Fit the DPST switch as close as possible to the Rosemount 2130. Keep the DPST switch free of obstructions. Label the DPST switch to indicate it is the supply disconnection device for the Rosemount 2130.

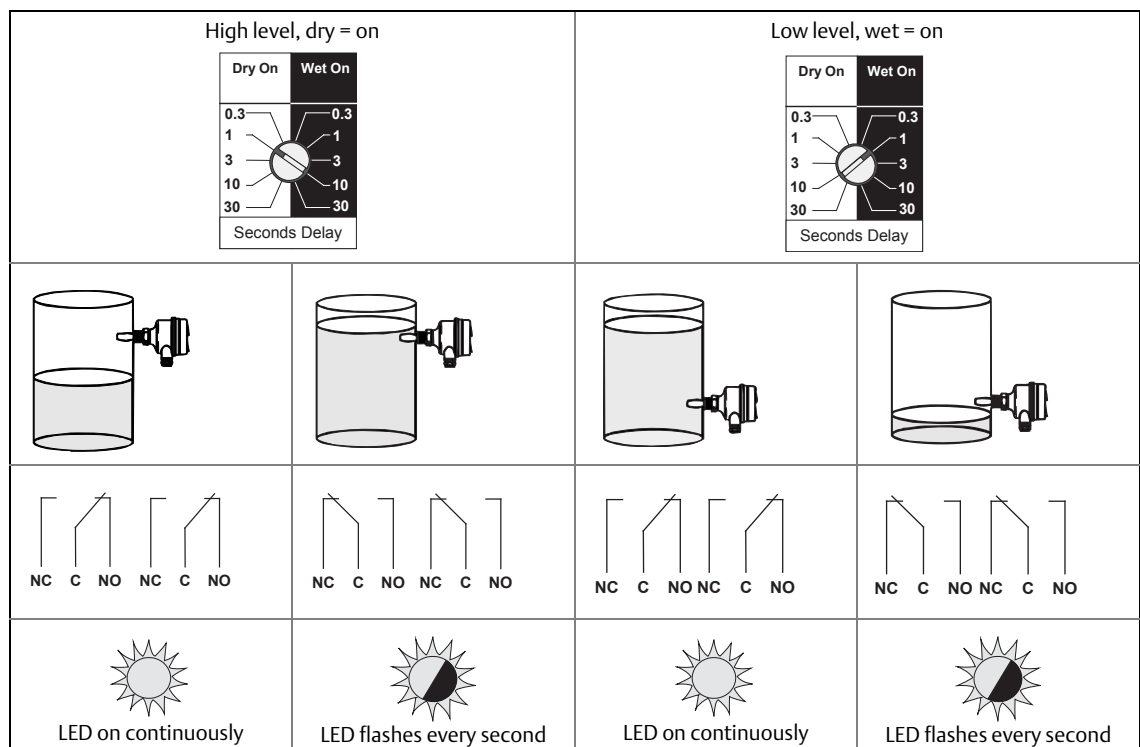

2.7.4 Fault and alarm relays (2 x SPCO) electronics cassette

Figure 2-25. SPCO Fault and Alarm Relays (Light Green Label)

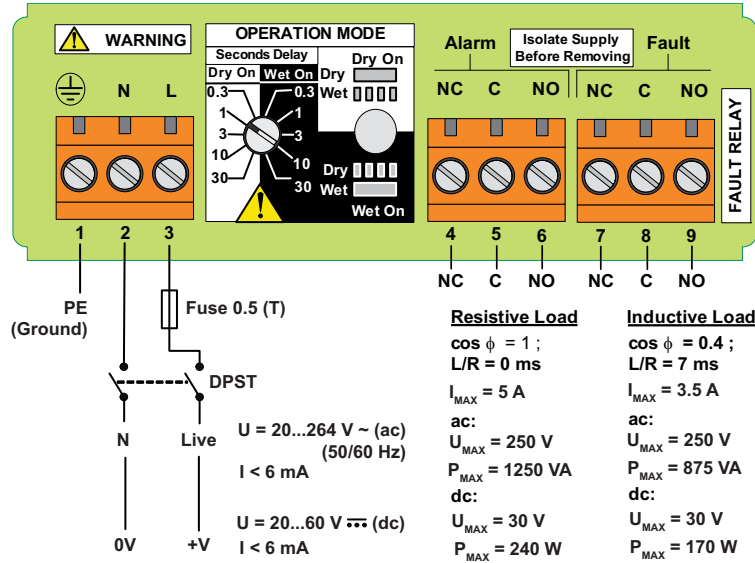

Note

A DPST (Double Pole, Single Throw) on/off switch must be installed to safely disconnect the power supply. Fit the DPST switch as close as possible to the Rosemount 2130. Keep the DPST switch free of obstructions. Label the DPST switch to indicate it is the supply disconnection device for the Rosemount 2130.

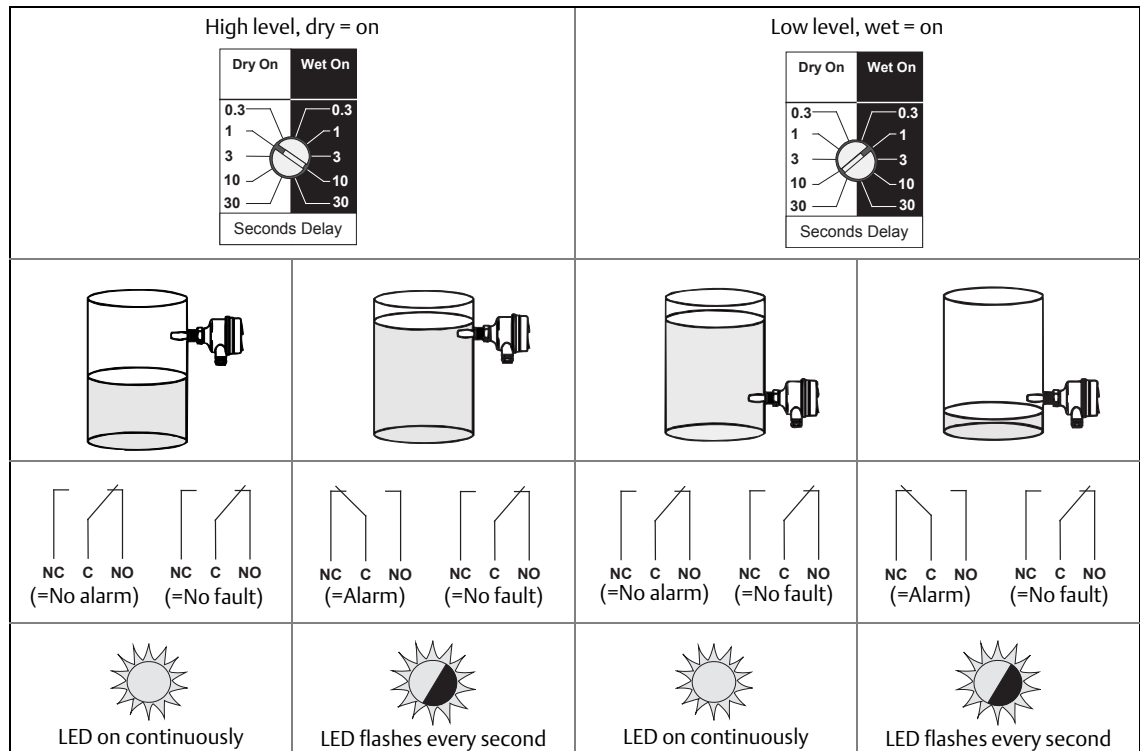

2.7.5 NAMUR electronics cassette

Figure 2-26. NAMUR (Light Blue Label)

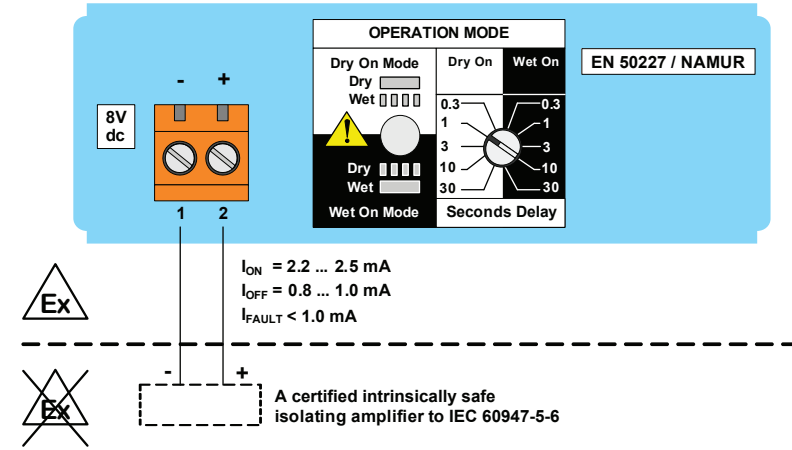

Note

This electronics cassette is suitable for Intrinsically Safe applications and requires a certified isolating barrier. See “Product Certifications” on page 51 for Intrinsically Safe approvals.

This electronics cassette is also suitable for non-hazardous (safe) area applications. It can only be interchanged with the 8/16 mA cassette.

Do not exceed 8 Vdc.

High level, dry = on		Low level, wet = on	
LED on continuously	LED flashes every second	LED on continuously	LED flashes every second

2.7.6 8/16 mA electronics cassette

Figure 2-27. 8/16 mA (Dark Blue Label)

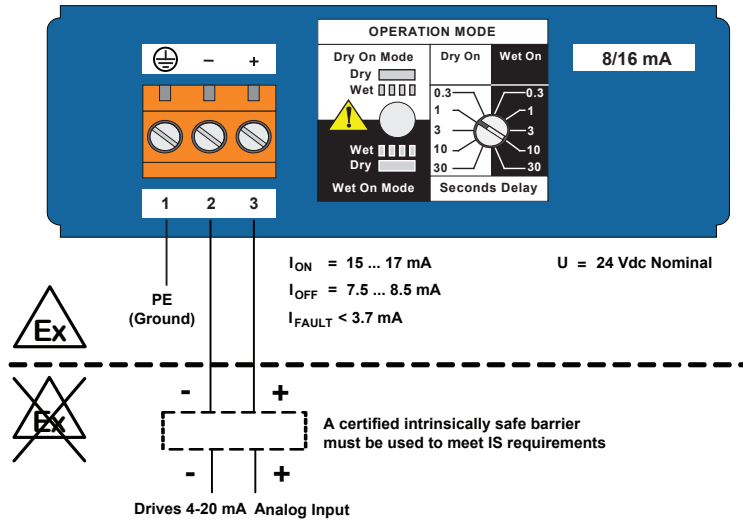

Note

This electronics cassette is suitable for Intrinsically Safe applications and requires a certified isolating barrier. See “Product Certifications” on page 51 for Intrinsically Safe approvals.

This electronics cassette is also suitable for non-hazardous (safe) area applications. In this case, $U = 11 - 36 \text{ V (dc)}$ and it can only be interchanged with a NAMUR cassette.

High level, dry = on		Low level, wet = on	
LED on continuously	LED flashes every second	LED on continuously	LED flashes every second

2.7.7 Fault condition detected (self-check mode only)

When a fault condition is detected in the self-check operating mode, the ‘heartbeat’ LED flashes once every half a second. The output from the level switch will then be as follows:

Table 2-3. Output When Fault Condition Detected

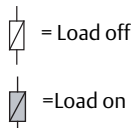
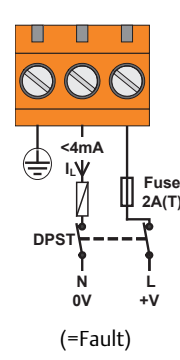
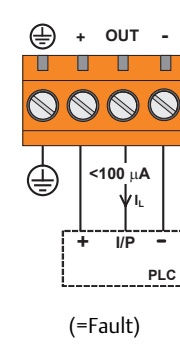
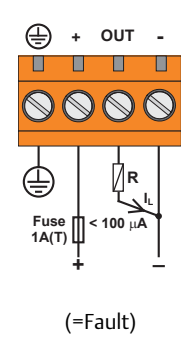
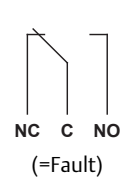
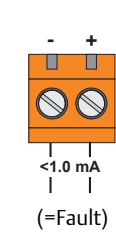
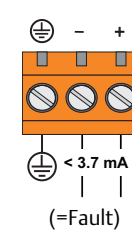
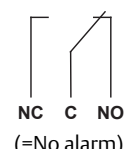
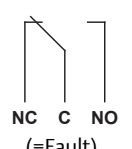
	Direct Load	PLC	PNP dc
	 <p>(=Fault)</p>	 <p>(=Fault)</p>	 <p>(=Fault)</p>
	 <p>(=Fault)</p>	 <p>(=Fault)</p>	 <p>(=Fault)</p>
<p>Fault and alarm (2 x SPCO) relays</p> <div style="display: flex; justify-content: space-around;"> <div style="text-align: center;"> <p>Alarm Relay</p>  <p>(=No alarm)</p> </div> <div style="text-align: center;"> <p>Fault Relay</p>  <p>(=Fault)</p> </div> </div>			

Note

See “LED indication” on page 21 for causes of other LED flashing rates.

Section 3 Service and Troubleshooting

Safety messages	page 31
Magnetic test point	page 32
Inspection	page 32
Maintenance	page 33
Spare parts	page 33
Troubleshooting	page 34
Service support	page 34
Replacement and calibration of electronic cassettes	page 35

3.1 Safety messages

Procedures and instructions in this manual may require special precautions to ensure the safety of the personnel performing the operations. Information that raises potential safety issues is indicated by a caution symbol (⚠). The external hot surface symbol (🔥) is used when a surface is hot and care must be taken to avoid possible burns. If there is a risk of an electrical shock, the (⚡) symbol is used. Refer to the safety messages listed at the beginning of each section before performing an operation preceded by this symbol.

⚠ WARNING

Failure to follow these installation guidelines could result in death or serious injury.

- Make sure only qualified personnel perform the installation.
- Use the Rosemount 2130 Level Switch (“level switch”) only as specified in this manual. Failure to do so may impair the protection provided by the equipment.
- The weight of the level switch with a heavy flange and extended fork length may exceed 37 lb. (18 kg). A risk assessment is required to be done before carrying, lifting, and installing the level switch.

Explosions could result in death or serious injury.

- Do not remove the level switch cover in explosive atmospheres when the circuit is alive.
- The level switch cover must be fully engaged and locked to meet explosion-proof requirements.
- Verify the operating environment of the level switch is consistent with the appropriate hazardous locations certifications.
- Review [Appendix B: Product Certifications](#) for special conditions and safety instructions associated with a hazardous location installation.

Process leaks could result in death or serious injury.

- Install and tighten process connection before applying pressure.
 - Do not attempt to loosen the process connection while the level switch is in service.
 - Make sure that the level switch is handled carefully. If the process seal is damaged, gas might escape from the tank.
-

⚠ WARNING

Electrical shock can result in death or serious injury.

- If the level switch is installed in a high-voltage environment and a fault or installation error occurs, high voltage may be present on the sensor leads and terminals.
- Use extreme caution when making contact with the leads and terminals.
- Make sure the main power to the level switch is off and the lines to any other external power source are disconnected or not powered while wiring the level switch.
- Ensure the wiring is suitable for the electrical current and the insulation is suitable for the voltage, temperature, and environment.

External surfaces may be hot.

- Care must be taken to avoid possible burns. The flange and process seal may also be hot at high process temperatures. Allow to cool before servicing.

3.2 Magnetic test point

A magnetic test-point is on the side of the housing (Figure 3-1), allowing a functional test of the Rosemount 2130 Level Switch. By touching a magnet on the target, the output will change state for as long as the magnet is held there.

Figure 3-1. Magnetic Test Point

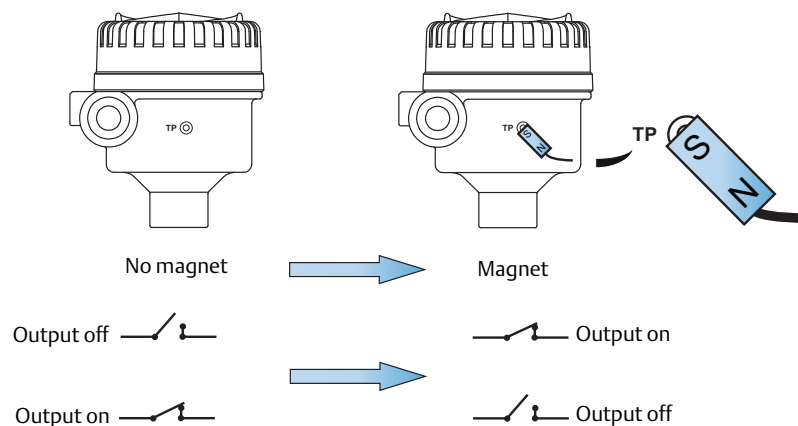

3.3 Inspection

- Visually examine the Rosemount 2130 Level Switch for damage. **If it is damaged, do not use.**
- Ensure the housing cover, cable glands, and blanking plugs are fitted securely.
- Fit a suitably rated blanking plug where required.
- Ensure the LED flash rate is once every second or continually on.
If anything else is demonstrated, see “LED indication” on page 21.

Figure 3-2. Visually Examine the Rosemount 2130

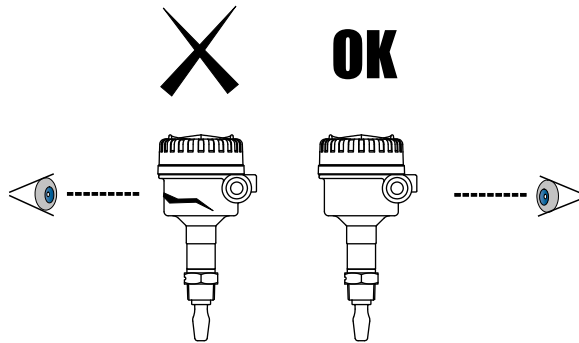

3.4 Maintenance

Figure 3-3. Maintenance

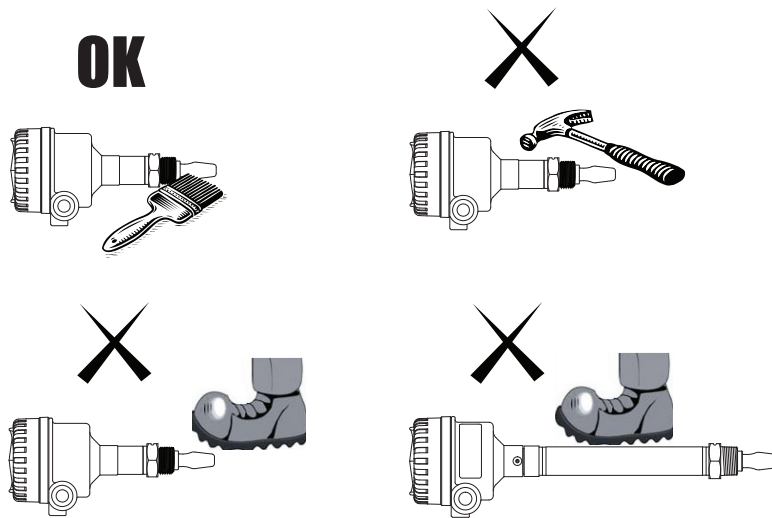

Note
Only use a soft brush for cleaning.

3.5 Spare parts

See “Spare parts and accessories” on page 49.

3.6 Troubleshooting

If there is a malfunction, see [Table 3-1](#) for information on possible causes.

Table 3-1. Troubleshooting Chart

Fault	Symptom/Indication	Action/Solution
Does not switch	<ul style="list-style-type: none"> No LED; no power 	<ul style="list-style-type: none"> Check the power supply; (check the load on direct load switching electronics)
	<ul style="list-style-type: none"> LED flashing 	<ul style="list-style-type: none"> See “LED indication” on page 21
	<ul style="list-style-type: none"> Fork is damaged 	<ul style="list-style-type: none"> Replace the Rosemount 2130
	<ul style="list-style-type: none"> Thick encrustation on the fork 	<ul style="list-style-type: none"> Clean the fork with care
	<ul style="list-style-type: none"> 5 second delay when changing mode/delay 	<ul style="list-style-type: none"> This is normal – wait 5 seconds
Incorrect switching	<ul style="list-style-type: none"> Dry = On, Wet = On set incorrectly 	<ul style="list-style-type: none"> Set the correct mode on the electronics cassette
Faulty switching	<ul style="list-style-type: none"> Turbulence 	<ul style="list-style-type: none"> Set a longer switching time delay
	<ul style="list-style-type: none"> Excessive electrical noise 	<ul style="list-style-type: none"> Suppress the cause of the interference
	<ul style="list-style-type: none"> Cassette has been fitted from another Rosemount 2130 	<ul style="list-style-type: none"> Fit the factory supplied cassette and then calibrate. (See “Replacement and calibration of electronic cassettes” on page 35)

3.7 Service support

To expedite the return process outside of the United States, contact the nearest Emerson representative.

Within the United States, call the Emerson Instrument and Valves Response Center using the 1 800 654 7768 toll-free number. This center, available 24 hours a day, will assist you with any needed information or materials.

The center will ask for product model and serial numbers, and will provide a Return Material Authorization (RMA) number. The center will also ask for the process material to which the product was last exposed.

⚠ CAUTION

Individuals who handle products exposed to a hazardous substance can avoid injury if they are informed of, and understand, the hazard. If the product being returned was exposed to a hazardous substance as defined by OSHA, a copy of the required Material Safety Data Sheet (MSDS) for each hazardous substance identified must be included with the returned goods.

3.8 Replacement and calibration of electronic cassettes

When replacing a damaged or faulty electronic cassette, calibrate the replacement cassette to the operating frequency of the fork assembly.

This section describes what is required for calibration. Calibration sequence steps 3 to 13 are time dependent and must be carried out within the noted times. The purpose of the time dependency and switching sequence is to prevent an accidental calibration from occurring.

If this replacement is taking place in a hazardous area, only qualified personnel should perform the replacement. All work in hazardous areas must be carried out in accordance with the local code. For general hazardous area requirements of this equipment, see [Appendix B: Product Certifications](#).

Calibration of the device is complex and it may take several attempts before calibration is successful.

3.8.1 Replacement sequence

On Intrinsically Safe (I.S.) approved versions of the Rosemount 2130 Level Switch, it is recommended that replacement and calibration be performed in a non-hazardous (safe) area.

Note

Intrinsically Safe approved cassettes can only be replaced with the same type of IS cassette.

Non-I.S. cassette types can be interchanged with other non-I.S. cassettes, but a new label must be fitted and the original part number transferred to the new label.

Before starting the replacement and calibration procedure, ensure that any controlled process will not be adversely affected.

To replace the cassette

1. Isolate and disconnect the power to the Rosemount 2130 Level Switch, and insulate the ends of the wires. On units with a relay cassette, there may be more than one power source
2. Remove the cover and disconnect the wires, noting any connections ([Figure 3-4](#)) and the exact mode switch position ([Figure 3-5](#)) on the cassette to be replaced.
3. Remove and retain the two fixing screws from the base of the cassette and unplug the cassette.
4. Plug in the replacement cassette, replace the screws, reconnect the wires, and set the mode switch to “Wet On” with a one second delay ([Figure 3-6](#)).
5. Reconnect the power to the unit.

Figure 3-4. Example of Installed Cassette

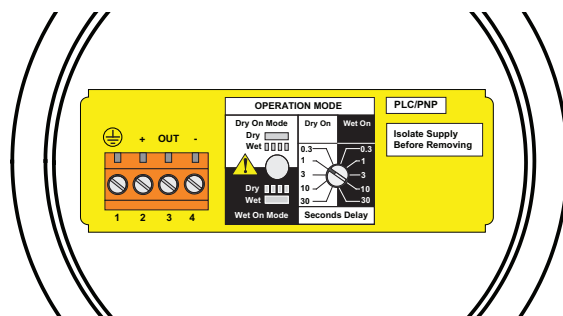
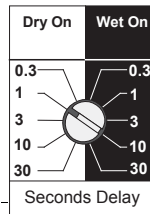

Figure 3-5. Mode Switch Setting (Existing Cassette)



This is an example of how the existing cassette may look. Here, the mode switch is set to “Dry On” with a one second delay.

Take note of the actual setting.

SETTING IS: _____

Figure 3-6. Mode Switch Setting (Replacement Cassette)

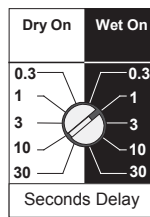

Set the mode switch of the new cassette to “Wet On” with a one second delay.

3.8.2 Calibration sequence

To calibrate the cassette

1. Ensure that the forks are dry, and the mode switch is set to “Wet On” with the time delay set to 1 second ([Figure 3-6](#)).
2. Check that the LED is flashing at a rate of one flash per second. Proceed to step [8](#) if it is on continuously.
3. Apply a magnet to the test-point (as shown on [page 32](#)).
4. After a one second delay, the LED will be lit continuously.
5. Within one second, rotate the mode switch two steps clockwise.
6. After a two second delay, the LED will go out.
7. Within three seconds, rotate the mode switch two steps counter-clockwise. Proceed to step [13](#).
8. Apply a magnet to the test-point (as shown on [page 32](#)).
9. After a one second delay, the LED will flash at a rate of one flash per second.
10. Within one second, rotate the mode switch two steps clockwise.
11. After a two second delay, the LED will go out (stop flashing).
12. Within three seconds, rotate the mode switch two steps counter-clockwise.
13. After a two second delay, the LED should flash twice per second.
14. If the LED is flashing twice per second, the calibration has occurred correctly. Remove the magnet from the test-point. After a one second delay, the unit will return to normal operation. Proceed to step [17](#).
15. If the LED is flashing once per second or it is on continuously, the calibration has failed. Remove the magnet from the test-point, wait ten seconds, and repeat from step [2](#).
16. If the LED stays off after the two second delay of step [13](#), the sensor is not working correctly. Check that the forks are clean and dry. Also, verify there is nothing jamming or touching the sensor. If no fault is found with the sensor, the entire unit should be returned for repair (see “[Product recycling and disposal](#)” on [page 5](#)).
17. Set the mode switch to the original setting noted in [Figure 3-5](#) and wait five seconds.
18. Replace the cover and check that the system works.

Appendix A Reference Data

Specifications	page 39
Dimensional drawings	page 42
Ordering information	page 46

A.1 Specifications

A.1.1 General

Product

Rosemount 2130 Level Switch

Measuring principle

Vibrating Fork

Applications

Most liquids including coating liquids, aerated liquids, and slurries

A.1.2 Mechanical

Housing / Enclosure

Table A-1. Housing / Enclosure Specification

Housing code	A-2	A-9	S-2	S-9
Housing material	Aluminum Alloy ASTM B85 A360.0		316C12 Stainless Steel	
Rotational	No	No	No	No
Housing paint	Polyurethane Paint		Not Applicable	
LED window	None		None	
Conduit entry	M20	3/4-in. ANPT	M20	3/4-in. ANPT
Ingress protection	IP66/67 to EN60529, NEMA 4X		IP66/67 to EN60529, NEMA 4X	

Connections

Threaded, Tri Clamp, and flanged process connections.
See [Table A-7 on page 46](#) for a complete list.

Extended lengths

Table A-2. Minimum Extended Lengths

Process connection	Minimum extended length
3/4-in. threaded	3.8 in. (95 mm)
1-in. threaded	3.7 in. (94 mm)
Flanged	3.5 in. (89 mm)
Tri Clamp	4.1 in. (105 mm)

The maximum extended length is 157.5 in. (4000 mm) except for the ECTFE co-polymer coating and polished process connection options which have a maximum length of 59.1 in. (1500 mm) and 39.4 in. (1000 mm) respectively.

Material selection

Emerson provides a variety of Rosemount product with various product options and configurations including materials of construction that can be expected to perform well in a wide range of applications. The Rosemount product information presented is intended as a guide for the purchaser to make an appropriate selection for the application. It is the purchaser's sole responsibility to make a careful analysis of all process parameters (such as all chemical components, temperature, pressure, flow rate, abrasives, contaminants, etc.), when specifying product, materials, options and components for the particular application.

Emerson is not in a position to evaluate or guarantee the compatibility of the process fluid or other process parameters with the product, options, configuration or materials of construction selected.

Process connection materials

316/316L Stainless Steel (1.4401/1.4404 dual certified).

Alloy C (UNS N10002) and Alloy C-276 (UNS N10276)
– available only for flanged, and BSPT and NPT threaded process connections (3/4- and 1-in. BSPT (R) and 3/4- and 1-in. NPT).

ECTFE co-polymer coated 316/316L stainless steel
(1.4401/1.4404 dual certified)
– only available for a flanged Rosemount 2130.

Gasket material for 3/4- and 1-in. BSPP (G) is non-asbestos BS7531 Grade X carbon fiber with rubber binder.

A.1.3 Functional

Maximum operating altitude

6562 ft. (2000 m)

Maximum operating pressure

The final rating depends on the type of process connection.

- Threaded connection: see [Figure A-1](#) for operating pressures.

Clamp glands 02120-2000-0001 and 02120-2000-0002 (page 49) limit the maximum pressure to 18.85 psig (1.3 bar g).

- Tri Clamp connection: 435 psig (30 bar g)
- Flanged Connection: See Figure A-1 or Table A-3 (whichever gives the lowest pressure).

Figure A-1. Process Pressure

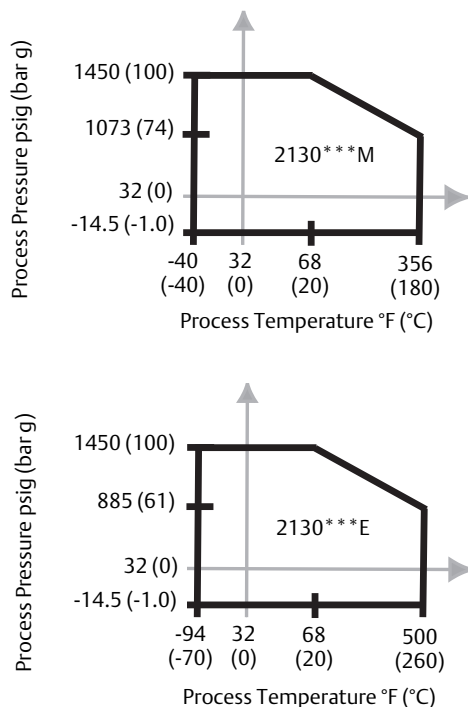

Minimum and maximum operating temperatures

- See Figure A-2 for operating temperatures.
- Clamp glands 02120-2000-0001 and 02120-2000-0002 (page 49) limit the maximum temperature to 257 °F (125 °C).
- The ambient temperature for a 8/16 mA cassette is limited to 158 °F (70 °C) in potentially explosive dust atmospheres.

Figure A-2. Operating Temperatures

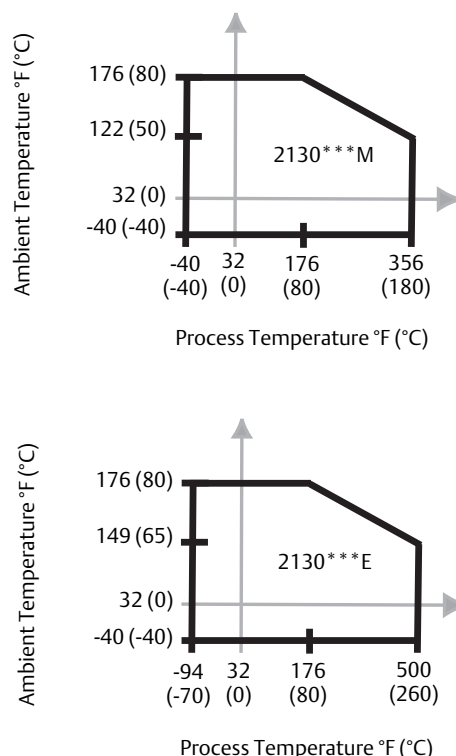

Table A-3. Maximum Flange Pressure Rating

Standard	Class/Rating	Stainless steel flanges
ASME B16.5	Class 150	275 psig ⁽¹⁾
ASME B16.5	Class 300	720 psig ⁽¹⁾
ASME B16.5	Class 600	1440 psig ⁽¹⁾
EN 1092-1	PN 10/16	16 barg ⁽²⁾
EN 1092-1	PN 25/40	40 barg ⁽²⁾
EN 1092-1	PN 63	63 barg ⁽²⁾
EN 1092-1	PN 100	100 barg ⁽²⁾

1. At 100 °F (38 °C), the pressure rating decreases with an increasing process temperature.
2. At 122 °F (50 °C), the pressure rating decreases with an increasing process temperature.

A.1.4 Performance

Hysteresis (water)

0.1 in. (± 2.5 mm)

Switching point (water)

0.5 in. (13 mm) from tip of fork (if vertical installation) or from edge of fork (if horizontal installation) – this will vary with different liquid densities

Liquid density requirement

Minimum standard density is 37.5 lb/ft³ (600 kg/m³).

Minimum density is 31.2 lb/ft³ (500 kg/m³) when ordered with the Low Density Range option.

Liquid viscosity range

Up to 10000 cP (centiPoise) when operating in the Normal mode.

Up to 1000 cP (centiPoise) when operating in Self-check mode.

Solids content and coating

The maximum recommended diameter of solid particles in the liquid is 0.2 in. (5 mm) when used in normal mode only.

For coating products, avoid bridging of forks.

Switching delay

There is a user-selectable 0.3, 1, 3, 10, 30 seconds delay for dry-to-wet and wet-to-dry switching.

CIP (Clean In Place) and SIP (Steam In Place) cleaning

Withstands cleaning routines up to 275 °F (135 °C).

NACE

NACE compliance to MR0175 / ISO 15156 or MR0103, depending on the option code selected for the model number.

Operating modes**Table A-4. Operating Modes**

Fault conditions detected	Normal mode (Red LED)	Self-check mode (Yellow LED)
PCB Control Circuit Corruption	Yes	Yes
External Damage to Fork	No	Yes
Internal Wire Disconnect/Break	No	Yes
Internal Damage to Sensor	No	Yes
Excessive Corrosion	No	Yes
Over-temperature	No	Yes

A.1.5 Electrical**Switching mode**

User-selectable switching mode (Dry = on or Wet = on)

Protection

Polarity insensitive

– on Direct Load and Relay electronics

Over-current protection

– on Direct Load and PNP/PLC electronics

Short-circuit protection

– on Direct Load and PNP/PLC electronics

Load-missing protection

– on Direct Load and PNP/PLC electronics

Surge protection (to IEC61326)

– Available on all versions of the Rosemount 2130

Magnetic test point

A magnetic test point is located on the side of the housing, allowing a functional test of the Rosemount 2130 and a system connected to it. By holding a magnet to the target, the output changes state for as long as the magnet is held there.

Terminal connection (wire diameter)

Minimum 26 AWG and maximum 14 AWG (0.13 to 2.5 mm²).

Note national regulations.

Conduit plugs/cable gland

Conduit entries for explosion-proof areas are shipped with one Exd plug (loose in bag) and two dust caps fitted. Use suitably rated cable glands. Unused conduit entries must be sealed with a suitably rated blanking plug. Local codes and regulations must be complied with.

Grounding

The Rosemount 2130 should always be grounded, either through the terminals or using the external ground connection provided.

A.2 Dimensional drawings

Figure A-3. $\frac{3}{4}$ - and 1-in. Threaded Mounting (Standard Length)

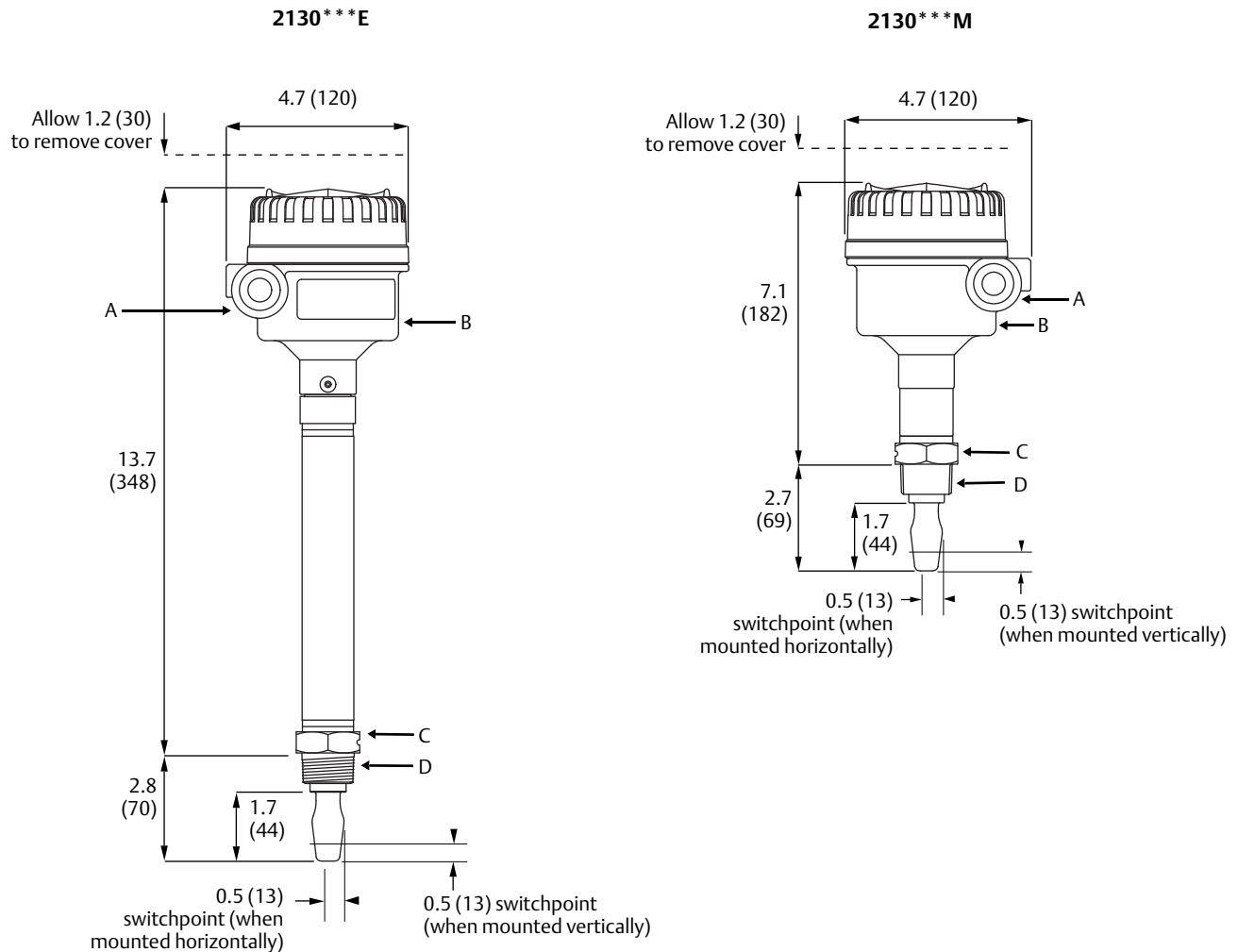

- A. Cable entry M20 x 1.5 or $\frac{3}{4}$ -in. ANPT
- B. Aluminum or stainless steel housing
- C. 1.575 (40) A/F hexagon
- D. $\frac{3}{4}$ -in. or 1-in. thread

Note

Dimensions are in inches (millimeters).

For hygienic Rosemount 2130 dimensions, see Type 1 drawing downloads on Emerson.com/Rosemount.

Figure A-4. 3/4- and 1-in. Thread Mounting (Extended Length)

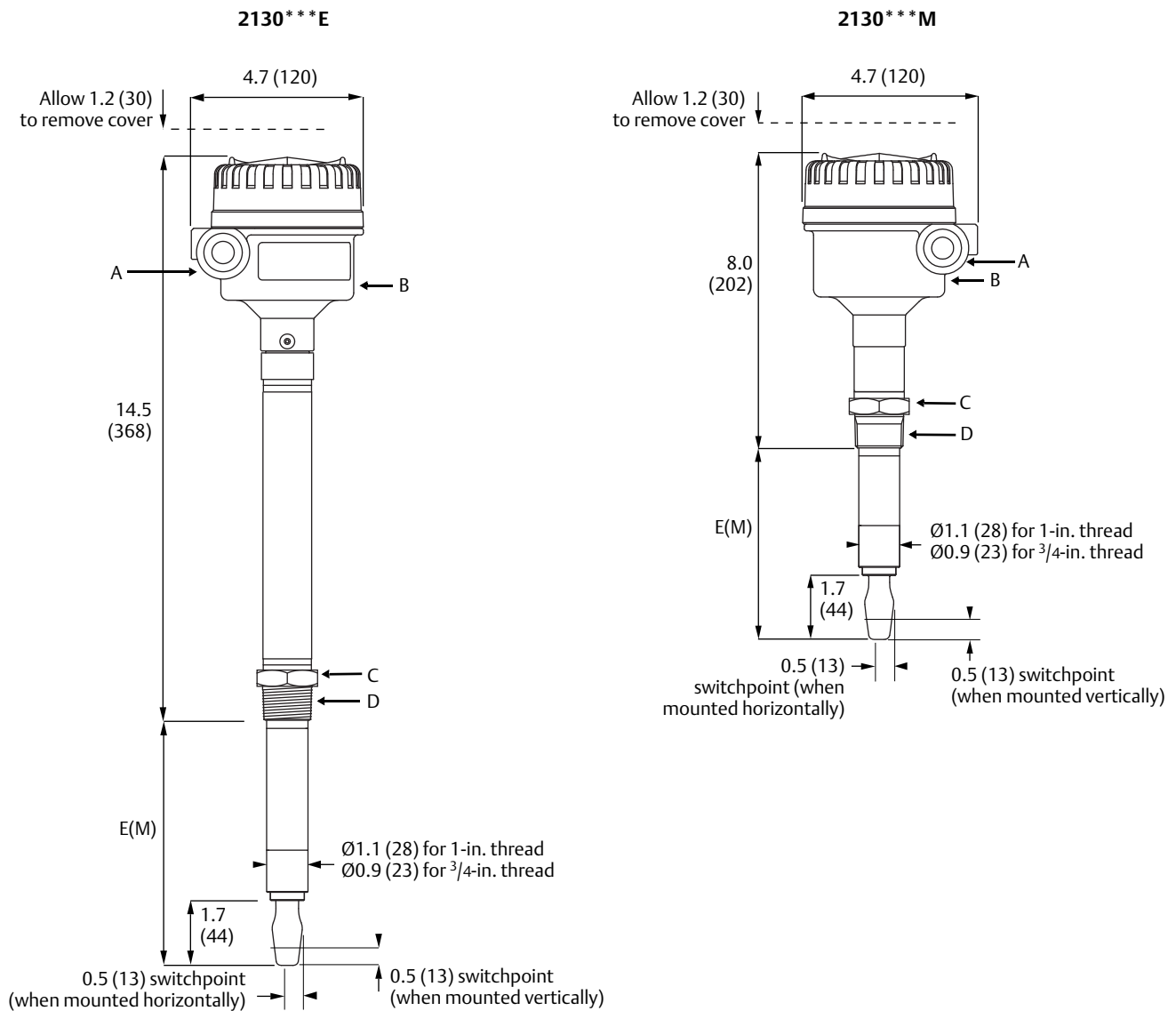

- A. Cable entry M20 x 1.5 or 3/4-in. ANPT C. 1.575 (40) A/F hexagon
B. Aluminum or stainless steel housing D. 3/4-in. or 1-in. thread

Note

Dimensions are in inches (millimeters).
For hygienic Rosemount 2130 dimensions, see Type 1 drawing downloads on Emerson.com/Rosemount.

Table A-5. Fork Length for Threaded Rosemount 2130

Process connection	Standard length Fork Length code A	Minimum length Fork Length code E (M)	Maximum length Fork Length code E (M) ⁽¹⁾
3/4-in. thread	1.73 in. (44 mm)	3.75 in. (95 mm)	157.5 in. (4000 mm)
1-in. thread	1.73 in. (44 mm)	3.74 in. (94 mm)	157.5 in. (4000 mm)

1. Maximum extended length of fork with hand-polished option is 39.4 in. (1000 mm).

Figure A-5. Flange Mounting (Standard Length)

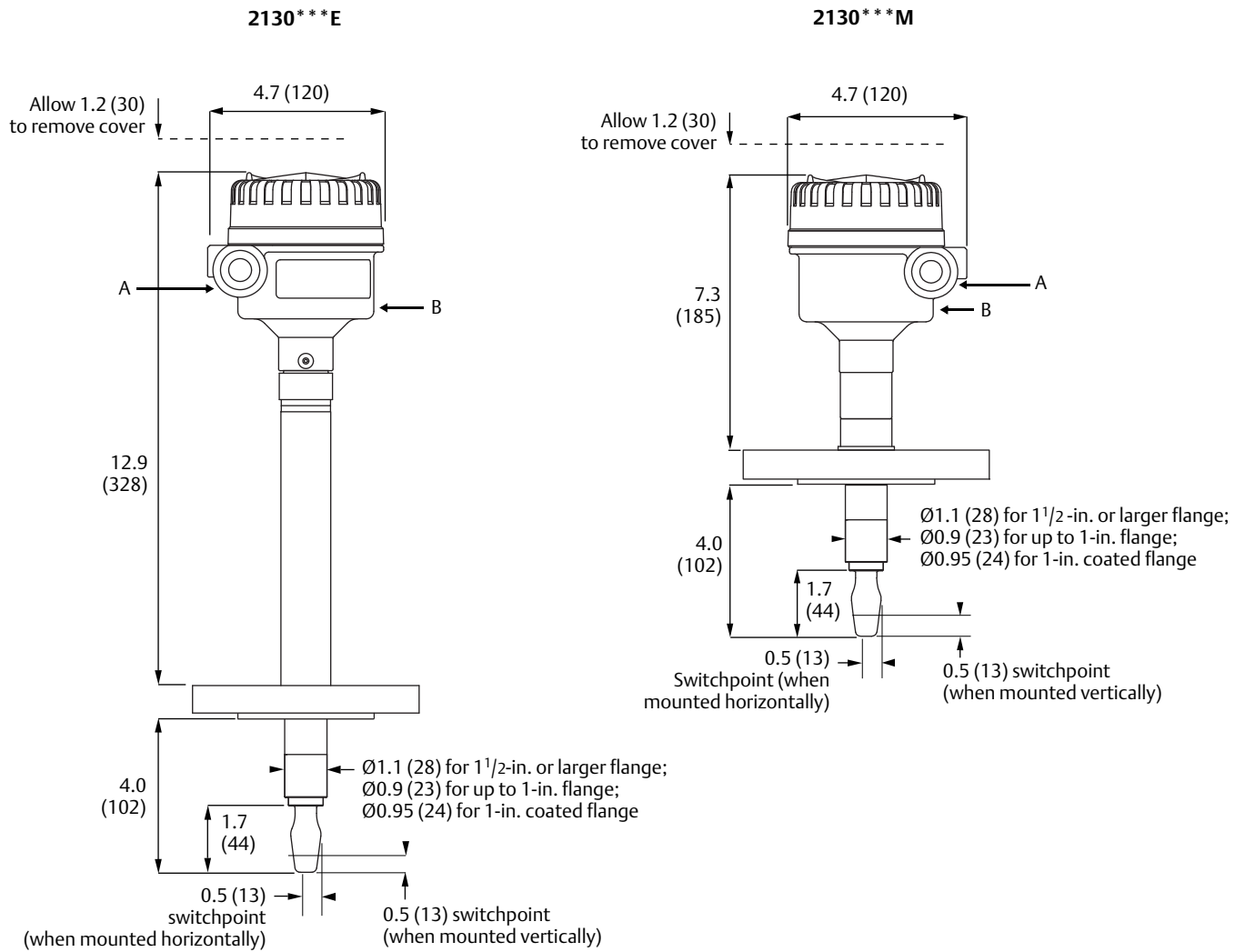

- A. Cable entry M20 x 1.5 or 3/4-in. ANPT
- B. Aluminum or stainless steel housing

Note
Dimensions are in inches (millimeters).

Figure A-6. Flange Mounting (Extended Length)

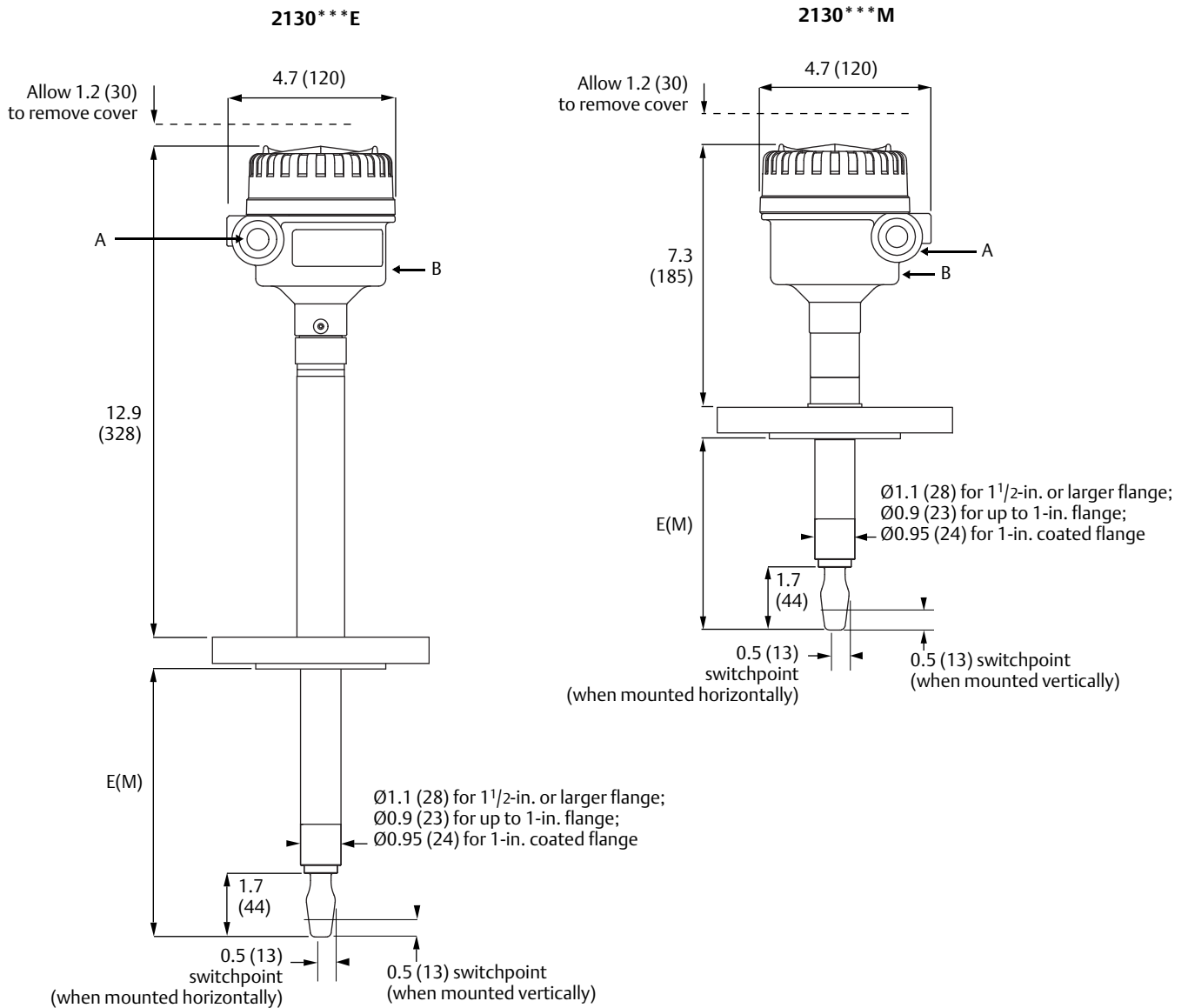

A. Cable Entry M20x1.5 or 3/4-in. ANPT B. Aluminum or stainless steel Housing

Note
Dimensions are in inches (millimeters).

Table A-6. Fork Length for Flanged Rosemount 2130

Material	Standard length fork length code H	Minimum length fork length code E(M)	Maximum length fork length code E(M) ⁽¹⁾
Stainless steel	4.0 in. (102 mm)	3.5 in. (89 mm)	157.5 in. (4000 mm)
ECTFE co-polymer coated	4.0 in. (102 mm)	3.5 in. (89 mm)	59.1 in. (1500 mm)

1. Maximum extended length of fork with hand-polished option is 39.4 in. (1000 mm).

A.3 Ordering information

Specification and selection of product materials, options, or components must be made by the purchaser of the equipment. See page 39 for more information on material selection.

Table A-7. Rosemount 2130 Ordering Information

The starred options (★) represent the most common options and should be selected for best delivery. The non-starred offerings are subject to additional delivery lead time.

Model	Product description	
2130	Enhanced Vibrating Fork Liquid Level Switch	
Output		
L	Direct Load Switching (Mains 2-wire) 20 to 264 Vac, 50/60 Hz, 20 to 60 Vdc, Self-checking	★
P	PNP/PLC Low Voltage (3-wire) 20 to 60 Vdc, Self-checking	★
D	Relay (DPCO), 20 to 264 Vac, 50/60 Hz, 20 to 60 Vdc, Self-checking	★
(Fault and Alarm Relays version is available by selecting D and adding "R2264" to the end of the model number)		
N	NAMUR, 8 Vdc, Self-checking	★
M	8/16 mA, Self-checking	★
Housing material		
A	Aluminum	★
S	Stainless Steel	★
Conduit entry / cable threads		Product certifications
9	3/4-in. ANPT	NA, E5, E6, G5, G6, I1, I2, I3, I5, I6, I7
2	M20	NA, E1, E2, E3, E7, I1, I2, I3, I5, I6, I7
Operating temperature		
M	Mid-Range: -40 °F (-40 °C)...356 °F (180 °C)	★
E	High: -94 °F (-70 °C)...500 °F (260 °C)	★
Materials of construction: process connection / fork⁽¹⁾		
S	316/316L Stainless Steel (1.4401/1.4404)	★
F ⁽²⁾⁽³⁾⁽⁴⁾	ECTFE Copolymer, Coated 316/316L Stainless Steel (1.4401/1.4404)	★
H ⁽⁵⁾	Alloy C (UNS N10002), Alloy C-276 (UNS N10276), solid	
Process connection size⁽⁶⁾		
9	3/4 in. / 19 mm	★
1	1 in. / 25 mm (DN25)	★
2	2 in. / 50 mm (DN50)	★
5	1 1/2 in. / 40 mm (DN40)	★
3	3 in. / 80 mm (DN80)	★
4	4 in. / 100 mm (DN100)	★
7	2 1/2 in. / 65 mm (DN65)	★
Process connection rating⁽⁶⁾		
AA	ASME B16.5 Class 150 flange	★
AB	ASME B16.5 Class 300 flange	★
AC	ASME B16.5 Class 600 flange	★
DA	EN1092-1 PN 10/16 flange	★

Table A-7. Rosemount 2130 Ordering Information

The starred options (★) represent the most common options and should be selected for best delivery. The non-starred offerings are subject to additional delivery lead time.

DB	EN1092-1 PN 25/40 flange			★
DC	EN1092-1 PN 63 flange			★
DD	EN1092-1 PN 100 flange			★
NN	For use with non-flange process connection type			★
Process connection type⁽⁶⁾				
R	Raised Face (RF) Flange			★
B	BSPT (R) Thread			★
G	BSPP (G) Thread			★
N	NPT Thread			★
P	BSPP (G) O-ring			★
C	Tri-Clover Clamp			★
Fork length			Process connection	
A	Standard length 1.7-in. (44 mm)		All except flanged models	★
H ⁽³⁾	Standard length flange 4.0-in. (102 mm)		All flanged models	★
E ⁽⁷⁾	Extended, customer specified length in tenths of inches		All except connection 1-NN-P	★
M ⁽⁷⁾	Extended, customer specified length in millimeters		All except connection 1-NN-P	★
Specific extended fork length				
0000	Factory default length (only if Fork Length A or H is selected)			★
XXXX ⁽⁷⁾	Specific customer specified length in tenths of inches, or millimeters (XXX.X inches or XXXX mm)			★
Surface finish			Process connection	
1	Standard surface finish		All	★
2 ⁽⁸⁾ (9)	Hand polished (Ra < 0.4 μm)		P or C	★
Product certifications		Output	Conduit entry/cable threads	
NA ⁽¹⁰⁾	No Hazardous Locations Certifications	All models	All models	★
G5 ⁽¹¹⁾	FM Ordinary Locations (unclassified, safe area)	All models	³ / ₄ -in. ANPT models only	★
G6 ⁽¹²⁾⁽¹³⁾	CSA Ordinary Locations (unclassified, safe area)	All models	³ / ₄ -in. ANPT models only	★
E1	ATEX Flameproof	All models	M20 models only	★
E2	INMETRO Flameproof	All except Fault Relays	M20 models only	★
E3	NEPSI Explosion-proof	All models	M20 models only	★
E5 ⁽¹¹⁾	FM Explosion-proof	All models	³ / ₄ -in. ANPT models only	★
E6 ⁽¹²⁾⁽¹³⁾	CSA Explosion-proof	All models	³ / ₄ -in. ANPT models only	★
E7	IECEX Explosion-proof	All models	M20 models only	★
EM	Technical Regulation Customs Union (EAC) Flameproof	All models	All models	★
I1	ATEX Intrinsic Safety	NAMUR or 8/16 mA	All models	★
I2	INMETRO Intrinsic Safety	NAMUR or 8/16 mA	All models	★
I3	NEPSI Intrinsic Safety	NAMUR or 8/16 mA	All models	★
I5	FM Intrinsic Safety	NAMUR or 8/16 mA	All models	★
I6 ⁽¹³⁾	CSA Intrinsic Safety	NAMUR or 8/16 mA	All models	★
I7	IECEX Intrinsic Safety	NAMUR or 8/16 mA	All models	★

Table A-7. Rosemount 2130 Ordering Information

The starred options (★) represent the most common options and should be selected for best delivery. The non-starred offerings are subject to additional delivery lead time.

IM	Technical Regulation Customs Union (EAC) Intrinsic Safety	NAMUR or 8/16 mA	All models	★
Typical model number: 2130 LA 2 E S 9 NN B A 0000 1 NA				

Options (include with the selected model number)

Calibration data certification				
Q4	Certificate of functional test			★
Material traceability certification⁽²⁾⁽³⁾				
Q8	Material traceability certification per EN 10204 3.1			★
Material certification⁽²⁾⁽³⁾				
Q15	NACE MR0175 / ISO 15156			★
Q25	NACE MR0103			★
Safety certifications⁽¹⁴⁾				
QS	Prior-use certificate of FMEDA data			★
QT	Safety certificate to IEC61508			★
Special procedures⁽¹⁵⁾				
P1	Hydrostatic testing with certificate			★
Low liquid density range				
LD	Low density liquids – minimum density is 31.2 lb/ft ³ (500 kg/m ³)			★
Example of options included with the model number: 2130 LA 2 E S 9 NN B A 0000 1 NA Q8				

1. Flanges are dual certified 316 and 316L Stainless Steel (1.4401 and 1.4404).
2. Only available for wetted parts.
3. Option is not available for hand polished wet side as standard.
4. Only available for a flanged Rosemount 2130. Also, the Operating Temperature code M must be selected (mid-range) and the maximum process temperature must be below 302 °F (150 °C).
5. Only available for BSPT and NPT threaded process connection codes 9-NN-B, 9-NN-N, 1-NN-B, and 1-NN-N as standard, other upon request.
6. Other process connections available upon request.
7. Example Fork Length code E1181 is 118.1 inches. Code M3000 is 3000 millimeters. See “Extended lengths” on page 39 for minimum and maximum extended lengths.
8. Not available with Material of Construction Process / Fork option code H.
9. Hand-polished for hygienic connections to better than 0.4 μm Ra such that there are no pits, folds, crevices or cracks discernible to the naked eye (i.e. no features larger than 75 micrometers based on resolving 1/60 degree at a distance of 250 mm).
10. Includes the Technical Regulation Customs Union (EAC) ordinary location mark.
11. See Appendix B: Product Certifications. E5 includes G5 requirements. G5 is for use in unclassified, safe area locations only.
12. See Appendix B: Product Certifications. E6 includes G6 requirements. G6 is for use in unclassified, safe area locations only.
13. The requirements of CRN are met when a Rosemount 2130 CSA approved vibrating fork level switch (with Product Certifications code G6, E6, or I6) is configured with stainless steel wetted parts and either NPT threaded or ASME B16.5 2-in. to 4-in. flanged process connections.
14. Not available for Direct Load switching electronics.
15. Option limited to units with extended lengths up to 59.1-in. (1500 mm). Option not available for ECTFE coating.



Safety Integrity Level (SIL) certification option

- The Rosemount 2130 is SIL2-certified.
- The Rosemount 2130 has been independently certified to IEC 61508 as required by IEC 61511. Certification was conducted by Exida. If required, add “QT” to the end of the model number. For example, 2130 LA 2 E S 9 NN B A 0000 1 NA Q8 QT (Note that you can have one or more OPTIONS codes at the end of the model number).
- Visit the [Rosemount 2130 web page](#) for additional information.

Overfill approval option

- The Rosemount 2130 has been TÜV-tested and approved for overfill protection according to the German DIBt/WHG regulations. This option is not selectable in the ordering information table. If required, add **"R2259"** to the end of the model number. For example, 2130 LA 2 E S 9 NN BA 0000 1 NA Q8 **R2259**
(Note that you can have one or more OPTIONS codes added at the end of the model number).

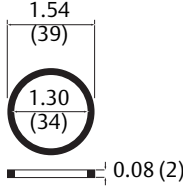
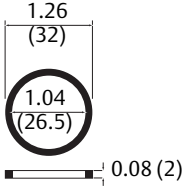
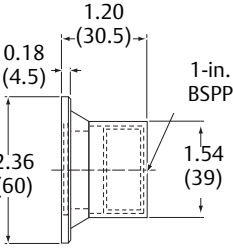
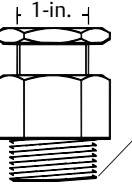
A.3.1 Spare parts and accessories

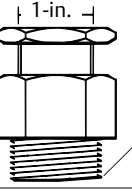
Part number	Spares and accessories	Part number	Spares and accessories
02100-1000-0001	Seal for 1-in. BSPP (G1A). Material: Non-asbestos BS7531 grade X carbon fiber with rubber binder 	02100-1040-0001	Seal for 3/4-in. BSPP (G3/4A) Material: Non-asbestos BS7531 grade X carbon fiber with rubber binder. 
02100-1010-0001	Adaptor boss 1-in. BSPP to 1 1/2-in. (38mm) Tri Clamp. Material: 316 SST fitting. FPM/FKM 'O' ring 	02120-2000-0001	Adjustable clamp gland for 1-in. extended lengths. Note: It is not explosion-proof. Material: 316 SST, (Si) Silicone rubber seal 
02100-1020-0001	2-in. (51-mm) Tri Clamp kit including vessel fitting, clamp ring, seal. Material: 316 SST, NBR Nitrile 	02120-2000-0002	Adjustable clamp gland for 1-in. extended lengths. Note: It is not explosion-proof. Material: 316 SST, (Si) Silicone rubber seal 
02100-1030-0001	Telescopic test magnet		
02100-1060-0001 ⁽¹⁾	Quick Release kit (includes 2-in. Tri Clamp, seal, and quick release device for 2-in. NPT process connection)		
Replacement cassettes⁽²⁾⁽³⁾			Replacement cassette for electronic type
02130-7000-0001	Direct load switching (Red)	Code L	
02130-7000-0002	PNP/PLC low voltage (Yellow)	Code P	
02130-7000-0003	NAMUR current switching (Light Blue)	Code N	
02130-7000-0004	DPCO Relay (Dark Green)	Code D	
02130-7000-0005	Direct load switching, low density range selection (Red)	Code L (for units with option LD)	
02130-7000-0006	PNP/PLC low voltage, low density range selection (Yellow)	Code P (for units with option LD)	

Part number	Spares and accessories	Part number	Spares and accessories
02130-7000-0007	NAMUR current switching, low density range selection (Light Blue)		Code N (for units with option LD)
02130-7000-0008	DPCO Relay, low density range selection (Dark Green)		Code D (for units with option LD)
02130-7000-0009	8/16 mA (Dark Blue)		Code M
02130-7000-0010	8/16 mA, low density range selection (Dark Blue)		Code M (for units with option LD)
02130-7000-0011	Fault and Alarm Relays (2 x SPCO) (Light Green)		Code F
02130-7000-0012	Same as 02130-7000-011 but with Low density range selection		Code F (for units with LD option)

1. The Quick Release kit is a set of accessories requiring a Rosemount 2130 with the 2-in. Tri Clamp option and an existing 2-in. NPT process connection on the vessel. For additional information, see the Quick Release kit – [Quick Start Guide](#).
2. Check the Electronic Type and Product Certification sections in [Table A-7 on page 46](#) for availability conditions.
3. Intrinsically Safe approved cassettes can only be replaced with the same type of IS cassette. Non-I.S. cassette types can be interchanged with other non-I.S. cassettes, but the new label must be fitted and the original part number transferred to the new label.

Appendix B Product Certifications

European directive information	page 51
European directive information	page 51
Overfill approval	page 51
Marine approvals	page 51
Drinking water approval	page 51
Marine approvals	page 51
NAMUR approval	page 51
Ordinary location certifications	page 51
Safety Integrity Level (SIL) certification	page 52
Canadian Registration Number	page 52
Hazardous locations certifications	page 52

B.1 European directive information

The EC declaration of conformity for all applicable European directives for this product can be found at Emerson.com/Rosemount.

B.2 NAMUR approval

NAMUR NE95 type test report available upon request.
Complies with NAMUR NE21

B.3 Overfill approval

Certificate number: Z-65.11-519.

TÜV-tested and approved for overfill protection according to the German DIBt/WHG regulations. Certified under safety devices for tanks and piping related to water pollution control.

B.4 Marine approvals

ABS – American Bureau of Shipping

GL – Germanischer Lloyd

SRS – Russian Maritime Registered Shipping (RMRS)

Note

The GL approval is not available for a Rosemount 2130 with the Fault and Alarm Relays electronics cassette fitted.

B.5 Drinking water approval

Rosemount Measurement Ltd., Slough, UK confirms that the wetted parts of the Rosemount type 2130 vibrating level switches are suitable and approved for use in potable water.

The wetted parts of the vibrating level switches executed in: stainless steel (option code S) and alloy C / alloy C-276 (option code H) with flanged (option code R), NPT thread (option code N), BSPT(R) thread (option code B) or Tri Clamp (option code C) process connections, are in accordance with the requirements of DVGW* - Worksheet W270. The materials used are classified as toxicologically and microbiologically safe.

B.6 Ordinary location certifications

FM ordinary location certification

G5 Project ID: 3021776

The switch has been examined and tested to determine that the design meets basic electrical, mechanical, and fire protection requirements by FM, a nationally recognized testing laboratory (NRTL) as accredited by the Federal Occupational Safety and Health Administration (OSHA).

CSA ordinary location certification

G6 Certificate Number 06 CSA 1805769

The switch has been examined and tested to determine that the design meets basic electrical, mechanical, and fire protection requirements by CSA, a nationally recognized testing laboratory as accredited by the Standards Council of Canada (SCC). Single Seal

B.7 Safety Integrity Level (SIL) certification

The Rosemount 2130 is SIL2-certified. It has been independently certified to IEC 61508 as required by IEC 61511. Certification was conducted by Exida.

A detailed Failure Modes, Effects and Diagnostics Analysis (FMEA) report for the Rosemount 2130 is available from Emerson. This report details all failure rates and failure modes as well as expected lifetime. The FMEA report is available from the Document and Drawings tab on the [Rosemount 2130 web page](#). There are SIL documents including the FMEA report, certificate, and Functional Safety Manual.

B.8 Canadian Registration Number

Certificate Number CRN 0F04227.2C

The requirements of CRN are met when a Rosemount 2130 CSA-approved vibrating fork level switch (with Product Certification codes G6, E6, or I6) is configured with stainless steel wetted parts and either a NPT threaded or ASME B16.5 2-in. to 8-in. flanged process connection.

B.9 Hazardous locations certifications

B.9.1 American and Canadian approvals

Factory Mutual (FM) explosion-proof approval

E5 Project ID: 3012658
Explosion-proof for Class I, Div. 1, Groups A, B, C, and D
Temperature Class: T6
Enclosure: Type 4X
(See also [Instructions specific to hazardous area installations \(E5 and E6\)](#)).

Canadian Standards Association (CSA) explosion-proof approval

E6 Project ID: 1786345
Explosion-proof for Class I, Div. 1, Groups A, B, C, and D
Temperature Class: T6
Enclosure: Type 4X
Single Seal
See also [Instructions specific to hazardous area installations \(E5 and E6\)](#).

Instructions specific to hazardous area installations (E5 and E6)

Model numbers covered:

2130**9E*****E5***,2130**9E*****E6***
2130**9M*****E5***,2130**9M*****E6***

("*" indicates options in construction, function and materials – see [Table A.3 on page 46](#))

The following instructions apply to equipment covered by CSA and FM explosion-proof approvals:

1. The equipment may be used with flammable gases and vapors with apparatus Class 1, Div 1, Groups A, B, C and D.
2. CSA and FM explosion-proof approved versions of the **2130***E** are certified for use in ambient temperatures of –58 to 167 °F (–50 to 75 °C), and with a maximum process temperature of 500 °F (260 °C).
CSA and FM explosion-proof approved versions of the **2130***M** are certified for use in ambient temperatures of –40 to 167 °F (–40 to 75 °C), and with a maximum process temperature of 356 °F (180 °C).
3. Installation of this equipment shall be carried out by suitably trained personnel, in accordance with the applicable code of practice.
4. Inspection and maintenance of this equipment shall be carried out by suitably trained personnel, in accordance with the applicable code of practice.
5. The user should not repair this equipment.
6. The certification of this equipment relies upon the following construction materials:

Body:

Aluminum alloy (ASTM B85 360.0) or 316 stainless steel

Cover:

Aluminum alloy (ASTM B85 360.0) or 316 stainless steel

Probe:

316 stainless steel, or alloy C276 (UNS N10276) and alloy C (UNS N10002)

Probe Filling: Perlite

Cover Seal: Silicone

7. If the equipment is likely to come into contact with aggressive substances, it is the responsibility of the user to take suitable precautions that prevent it from being adversely affected, thus ensuring that the type of protection is not compromised.
Aggressive Substances – e.g. acidic liquids or gases that may attack metals or solvents that may affect polymeric materials.
Suitable Precautions – e.g. regular checks as part of routine inspections or establishing from the material's data sheet that it is resistant to specific chemicals.
The metallic alloy used for the enclosure material may be at the accessible surface of this equipment; in the event of rare accidents, ignition sources due to impact and friction sparks could occur. This shall be considered when the Rosemount 2130 is installed in locations that specifically require Class 1, Div 1 equipment.
8. It is the responsibility of the user to ensure:
 - a. The voltage and current limits for this equipment are not exceeded.
 - b. That the joint requirements between the probe (switch) and the vessel tank are compatible with the process media.

- c. That the joint tightness is correct for the joint material used.
 - d. That only suitably certified cable entry devices will be utilized when connecting this equipment.
 - e. That any unused cable entries are sealed with suitably certified stopping plugs.
9. The probe fork is subjected to small vibration stresses as part of its normal function. As this provides a partition wall, it is recommended that the fork should be inspected every two years for signs of defects.
10. Technical data:
- a. Coding: Class 1, Div 1, Groups A, B, C, and D
 - b. Temperature: See [Table B-1](#) or [Table B-2](#)
 - c. Pressure: Must not exceed the rating of the coupling/flange fitted.
 - d. For electrical details and pressure ratings, refer to “Specifications” on page 39.
 - e. Year of manufacture: Printed on product label.

Table B-1. High temperature Rosemount 2130

2130**9E*****E5***,

2130**9E*****E6***:

Temperature classes	Maximum ambient air temperature (Ta)	Maximum process temperature (Tp)
T6, T5, T4, T3, T2, T1	75 °C	80 °C
T5, T4, T3, T2, T1	74 °C	95 °C
T4, T3, T2, T1	73 °C	125 °C
T3, T2, T1	69 °C	185 °C
T2, T1	65 °C	260 °C

Minimum ambient air temperature (Ta) = -50 °C

Minimum process temperature (Tp) = -70 °C

Table B-2. Medium temperature Rosemount 2130

2130**9M*****E5***,

2130**9M*****E6***:

Temperature classes	Maximum ambient air temperature (Ta)	Maximum process temperature (Tp)
T6, T5, T4, T3, T2, T1	75 °C	75 °C
T5, T4, T3, T2, T1	70 °C	90 °C
T4, T3, T2, T1	65 °C	125 °C
T3, T2, T1	50 °C	180 °C

Minimum ambient air temperature (Ta) = -40 °C

Minimum process temperature (Tp) = -40 °C

11. Cable selection:

- a. It is the responsibility of the user to ensure that suitably temperature rated cable is used. [Table B-3](#) below is a guide to selection.

Table B-3. Cable Selection (E5 and E6)

T Class	Cable Temperature Rating
T6	Above 185 °F (85 °C)
T5	Above 212 °F (100 °C)
T4	Above 275 °F (135 °C)
T3	Above 320 °F (160 °C)

Note

A certified isolating amplifier to IEC 60947-5-6 is required for intrinsic safety if the NAMUR electronics is used in a hazardous area installation (see below).

A certified intrinsically safe barrier is required for intrinsic safety if the 8/16 mA electronics is used in a hazardous area installation (see below).

Factory Mutual (FM)

intrinsically safe and non-incendive approvals

- I5** Project ID: 3011456
 Intrinsically Safe for Class I, Div. 1, Groups A, B, C, and D
 Class I, Zone 0, AEx ia IIC
 Non-incendive for Class I, Div. 2, Groups A, B, C, and D
 Class I, Zone 2, IIC
 Temperature Code: T5 (See Control Drawings)
 Control Drawing: 71097/1154 (with NAMUR electronics) ([Figure B-1 on page 55](#))
 Vmax=15 V, Imax=32 mA, Pi=0.1 W, Ci=211 nF, Li=0.06 mH
 Control Drawing: 71097/1314 (with 8/16 mA electronics) ([Figure B-2 on page 56](#))
 Vmax=30 V, Imax=93 mA, Pi=0.65 W, Ci=12 nF, Li=0.035 mH
 See also “Instructions for hazardous (classified loc.) area installations (I5 and I6)” on page 54.

Canadian Standards Association (CSA)

intrinsically safe and non-incendive approvals

- I6** Certificate Number: 06 CSA 1786345
 Intrinsically Safe for Class I, Div. 1, Groups A, B, C, and D
 Class I, Zone 0, Ex ia IIC
 Non-incendive for Class I, Div. 2, Groups A, B, C, and D
 Temperature Code: T5 (See Control Drawings)
 Single Seal
 Control Drawing: 71097/1179 (with NAMUR electronics) ([Figure B-3 on page 57](#))
 Vmax=15 V, Imax=32 mA, Pi=0.1 W, Ci=211 nF, Li=0.06 mH
 Control Drawing: 71097/1315 (with 8/16 mA electronics) ([Figure B-4 on page 58](#))
 Vmax=30 V, Imax=93 mA, Pi=0.65 W, Ci=12 nF, Li=0.035 mH
 See also “Instructions for hazardous (classified loc.) area installations (I5 and I6)” on page 54.

Instructions for hazardous (classified loc.) area installations (I5 and I6)

Model numbers covered:

2130N*****I5***, 2130N*****I6***
2130M*****I5***, 2130M*****I6***

("*" indicates options in construction, function and materials – see [Table A.3 on page 46](#))

The following instructions apply to equipment covered by CSA and FM intrinsically safe and non-incendive approvals:

1. The **Intrinsically Safe** approved Rosemount 2130 may be used in hazardous locations with flammable gases and vapors Class 1 **Division 1** Groups A, B, C, and D, and Class 1 Zone 0 Group IIC when installed in accordance with control drawings:

71097/1154 ([Figure B-1 on page 55](#))
71097/1314 ([Figure B-2 on page 56](#))
71097/1179 ([Figure B-3 on page 57](#))
71097/1315 ([Figure B-4 on page 58](#))

2. The **Non-incendive** approved Rosemount 2130 may be used in hazardous locations with flammable gases and vapors Class 1 **Division 2** Groups A, B, C, and D when installed in accordance with control drawings:

71097/1154 ([Figure B-1 on page 55](#))
71097/1314 ([Figure B-2 on page 56](#))
71097/1179 ([Figure B-3 on page 57](#))
71097/1315 ([Figure B-4 on page 58](#))

3. The apparatus electronics is only certified for use in ambient temperatures in the range of –50 to +80 °C. It should not be used outside this range. However, the switch may be located in the process medium which may be at a higher temperature than the electronics but must not be higher than the Temperature Class for the respective process gas/medium.
4. It is a condition of the approval that the temperature of the electronics is in the range of –58 to +176 °F (–50 to +80 °C). It must not be used outside this range. It will be necessary to limit the external ambient temperature if the process temperature is high.
5. Suitably trained personnel shall carry out installation in accordance with the applicable code of practice.
6. The user should not repair this equipment.
7. If the equipment is likely to come into contact with aggressive substances, it is the responsibility of the user to take suitable precautions that prevent it from being adversely affected, thus ensuring that the type of protection is not compromised.

Aggressive Substances – e.g. acidic liquids or gases that may attack metals or solvents that may affect polymeric materials.

Suitable Precautions – e.g. regular checks as part of routine inspections or establishing from the material's data sheet that it is resistant to specific chemicals.

8. If the enclosure is made of an alloy or plastic material, the following precautions must be observed:
 - a. The metallic alloy used for the enclosure material may be at the accessible surface of this equipment; in the event of rare accidents, ignition sources due to impact and friction sparks could occur.
 - b. Under certain extreme circumstances, the non-metallic parts incorporated in the enclosure of the Rosemount 2130 may generate an ignition-capable level of electrostatic charge. Therefore, when they are used for applications that specifically require group II equipment, the Rosemount 2130 shall not be installed in a location where the external conditions are conducive to the build-up of electrostatic charge on such surfaces. Additionally, the Rosemount 2130 shall only be cleaned with a damp cloth.

9. Technical Data

- a. I.S. approval: Class 1 Division 1 Groups A, B, C, and D; Class 1 Zone 0 AEx ia IIC
Non-incendive approval: Class 1 Division 2 Groups A, B, C, and D; Class I, Zone 2, IIC
- b. Input parameters:
Rosemount 2130 with NAMUR electronics:
Vmax=15 V, Imax=32 mA, Pi=0.1 W, Ci=211 nF, Li=0.06 mH
Rosemount 2130 with 8/16 mA electronics:
Vmax=30 V, Imax=93 mA, Pi=0.65 W, Ci=12 nF, Li=0.035 mH
- c. Temperature:
See Control Drawings:
71097/1154 ([Figure B-1 on page 55](#))
71097/1314 ([Figure B-2 on page 56](#))
71097/1179 ([Figure B-3 on page 57](#))
71097/1315 ([Figure B-4 on page 58](#))
- d. Materials: See ["Specifications" on page 39](#).
- e. Year of manufacture: Printed on product label.

Figure B-2. FM Intrinsically Safe Control Drawing (8/16 mA Electronics)

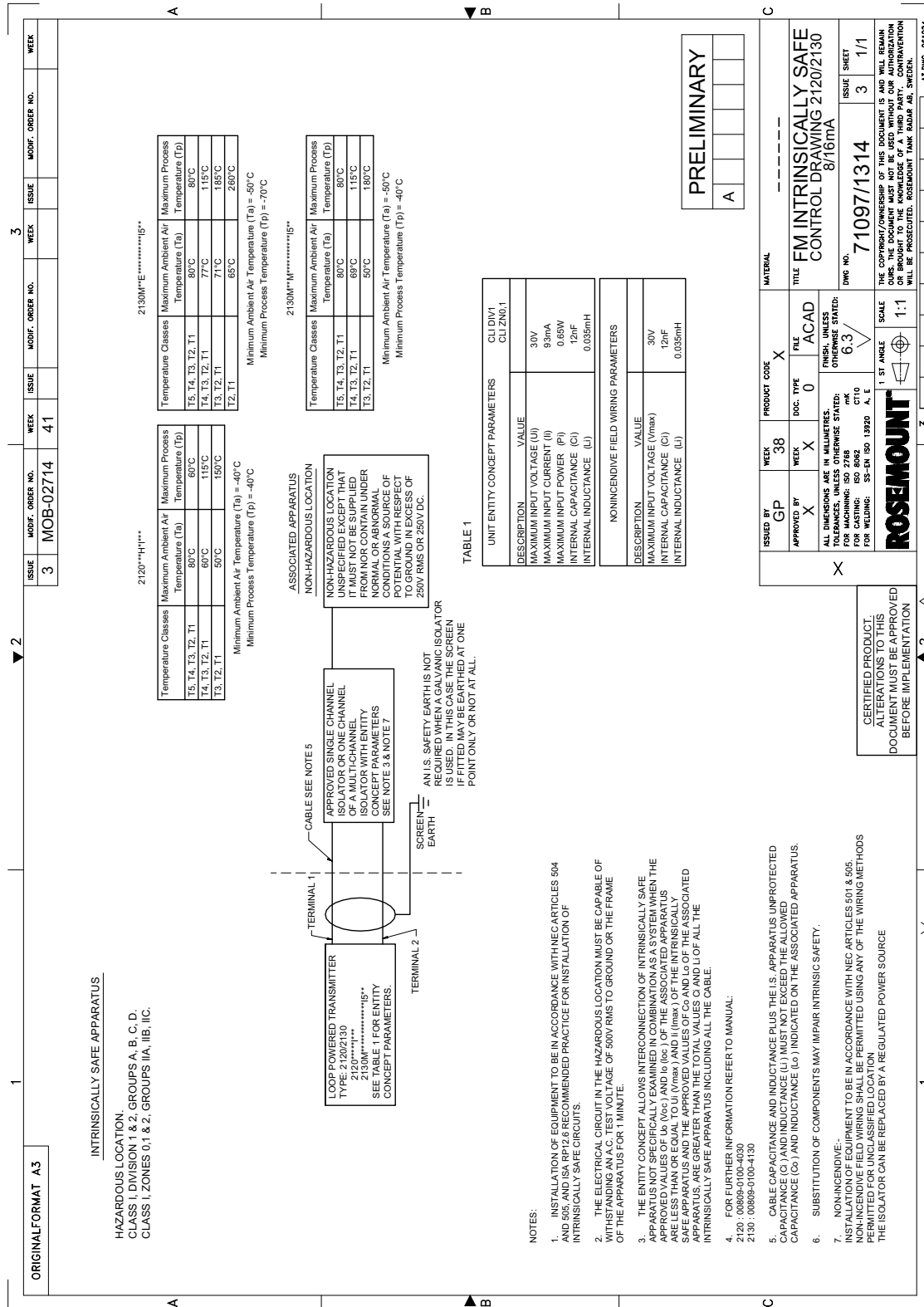
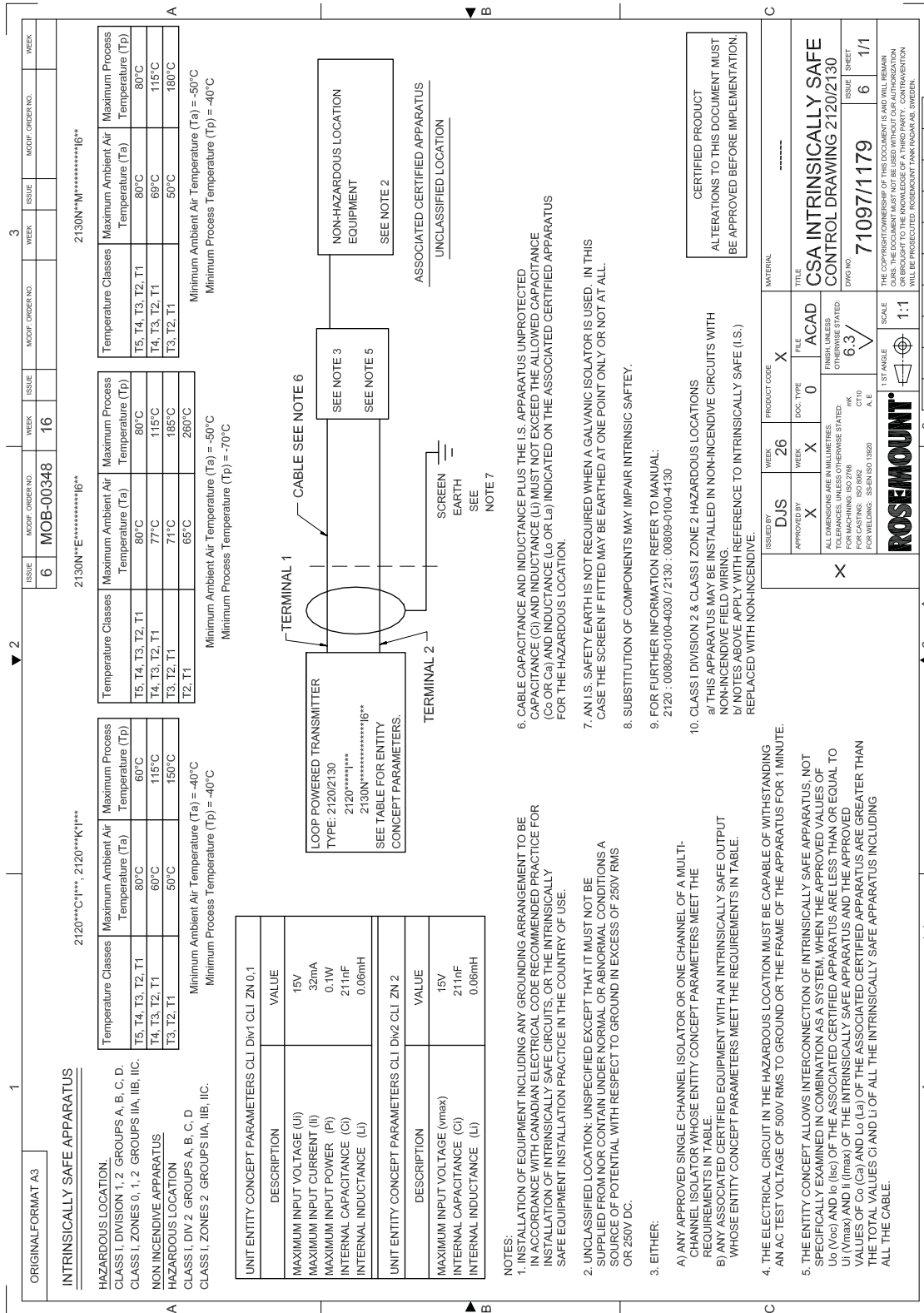

Figure B-3. CSA Intrinsically Safe Control Drawing (NAMUR Electronics)



B.9.2 European approvals

Note

A certified isolating amplifier to IEC 60947-5-6 is required for intrinsic safety approvals if the NAMUR electronics is used in a hazardous area installation (see below).
A certified intrinsically safe barrier is required for intrinsic safety if the 8/16 mA electronics is used in a hazardous area installation (see below).

ATEX flameproof and dust proof approval

E1 Certificate: Sira 05ATEX1129X

Flameproof and dust proof:
ATEX Marking Ⓔ II 1/2 G D
Ex db IIC T6...T2 Ga/Gb
Ex tb IIIC T85 °C...T265 °C Db

See also "Instructions specific to hazardous area installations (E1 and E7)" on page 62.

ATEX intrinsically safe approval

I1 Certificate: Sira 05ATEX2130X

Intrinsic Safety for gas and dust atmospheres:
ATEX Marking Ⓔ II 1 G D
Ex ia IIC T5...T2 Ga
Ex ia IIIC T85 °C...T265 °C Da

(See also "Instructions specific to hazardous area installations (I1 and I7)" on page 60.

B.9.3 International approvals

Note

A certified isolating amplifier to IEC 60947-5-6 is required for intrinsic safety approvals if the NAMUR electronics is used in a hazardous area installation (see below).
A certified intrinsically safe barrier is required for intrinsic safety if the 8/16 mA electronics is used in a hazardous area installation (see below).

INMETRO flameproof and dust proof approval

E2 Certificate Number: TÜV 12.1285 X

Flameproof and dust proof:
Ex d IIC T6 to T2 Ga/Gb, Ex tb IIIC T85 °C to T265 °C Db

INMETRO intrinsically safe approval

I2 Certificate Number: TÜV 12.1391 X

Intrinsic Safety for gas and dust atmospheres:
Ex ia IIC T* Ga, Ex ia IIIC T* Da (* See table in the certificate)
Ta* (* See table in the certificate)

Security parameters

NAMUR:

$U_i = 15 \text{ V} / I_i = 32 \text{ mA} / P_i = 0,1 \text{ W} / C_i = 12 \text{ nF} / L_i = 0,06 \text{ mH}$

8/16 mA:

$U_i = 30 \text{ V} / I_i = 93 \text{ mA} / P_i = 0,65 \text{ W} / C_i = 12 \text{ nF} / L_i = 0,035 \text{ mH}$

Safe use special condition

Non-metallic parts of the equipment casing can generate electrostatic charges under extreme conditions. The equipment should only be cleaned with a damp cloth.

National Supervision and Inspection Centre for Explosion Protection and Safety Instrumentation (NEPSI) flameproof approval

E3 Certificate: GYJ101373

Flameproof and dust proof:
Ex d IIC T6~T2
DIP A21 T_A (T85 °C ~ 265 °C) IP6X

See "Instructions specific to hazardous area installations (E3)" on page 64.

National Supervision and Inspection Centre for Explosion Protection and Safety Instrumentation (NEPSI) intrinsically safe approval

I3 Certificate: GYJ101372X

Intrinsic Safety (NAMUR electronics):
Ex ia IIC T5~T2
 $U_i = 15 \text{ V}, I_i = 32 \text{ mA}, P_i = 0.1 \text{ W}, C_i = 12 \text{ nF}, L_i = 0.06 \text{ mH}$

See "Instructions specific to hazardous area installations (I3)" on page 63.

International Electrotechnical Commission (IEC) flameproof and dust proof approval

E7 Certificate: IECEx SIR 06.0051X

Flameproof and dust proof:
Ex db IIC T6...T2 Ga/Gb
Ex tb IIIC T85 °C...T265 °C Db

See "Instructions specific to hazardous area installations (E1 and E7)" on page 62.

International Electrotechnical Commission (IEC) intrinsically safe and dust approval

I7 Certificate: IECEx SIR 06.0070X

Intrinsically Safe for gas and dust atmospheres:
Ex ia IIC T5...T2 Ga
Ex ia IIIC T85 °C...T265 °C Da

See "Instructions specific to hazardous area installations (I1 and I7)" on page 60.

Technical Regulation Customs Union (EAC) flameproof approval

EM Certificate: RU C-GB.AB72.B.01385
(M20 conduit entry/cable thread only)

Markings for 2130***M:
1Exd IIC T6 X (-40 °C ≤ Ta ≤ +75 °C);
1Exd IIC T5 X (-40 °C ≤ Ta ≤ +70 °C);
1Exd IIC T4 X (-40 °C ≤ Ta ≤ +65 °C);
1Exd IIC T3 X (-40 °C ≤ Ta ≤ +50 °C)

Markings for 2130***E:
1Exd IIC T6 X (-40 °C ≤ Ta ≤ +75 °C);
1Exd IIC T5 X (-40 °C ≤ Ta ≤ +74 °C);
1Exd IIC T4 X (-40 °C ≤ Ta ≤ +73 °C);
1Exd IIC T3 X (-40 °C ≤ Ta ≤ +69 °C);
1Exd IIC T2 X (-40 °C ≤ Ta ≤ +65 °C)

See certificate for special conditions for safe use (X)

**Technical Regulation Customs Union (EAC)
intrinsically safe approval**

IM Certificate: RU C-GB.AB72.B.01385
(NAMUR and 8/16 mA electronics only)

Markings for 2130***M:
0Exia IIC T5 X (-50 °C ≤ Ta ≤ +80 °C);
0Exia IIC T4 X (-50 °C ≤ Ta ≤ +69 °C);
0Exia IIC T3 X (-50 °C ≤ Ta ≤ +50 °C)

Markings for 2130***E:
0Exia IIC T5 X (-50 °C ≤ Ta ≤ +80 °C);
0Exia IIC T4 X (-50 °C ≤ Ta ≤ +77 °C);
0Exia IIC T3 X (-50 °C ≤ Ta ≤ +71 °C);
0Exia IIC T2 X (-50 °C ≤ Ta ≤ +65 °C)

See certificate for special conditions for safe use (X)

Instructions specific to hazardous area installations (I1 and I7)

Model numbers covered:

2130M**E*****I1****,
2130M**M*****I1****,
2130M**E*****I7****,
2130M**M*****I7****,
2130N**E*****I1****,
2130N**M*****I1****,
2130N**E*****I7****,
2130N**M*****I7****

("*" indicates options in construction, function and materials – see Table A.3 on page 46)

The following instructions apply to the equipment covered by certificates **Sira 05ATEX2130X** and **IECEx SIR 06.0070X**:

1. The Intrinsically Safe (I.S.) approved version of the 2130 may be used in a hazardous area with explosive gases and vapors with apparatus groups IIC, IIB, and IIA, and with temperature classes T1, T2, T3, T4, and T5 [IECEx: in Zone 0, 1, and 2]. The temperature class of the installation will be determined from the higher of the process or ambient temperature.
2. The equipment may be used in a hazardous area with explosive dusts with apparatus groups IIIC, IIIB, and IIIA [IECEx: in Zones 20, 21, and 22]. The maximum surface temperature of the installation will be determined from the higher of the process or ambient temperature.
3. It is a special condition of the certification that the temperature of the electronics housing is in the range of -50 to 80 °C. It must not be used outside this range.

It will be necessary to limit the external ambient temperature if the process temperature is high. (See "Technical Data" below).

4. Suitably trained personnel shall carry out installation in accordance with the applicable code of practice.
5. The user should not repair this equipment.
6. If the equipment is likely to come into contact with **aggressive substances**, it is the responsibility of the user to take **suitable precautions** that prevent it from being adversely affected, thus ensuring that the type of protection is not compromised.
Aggressive substances: e.g. acidic liquids or gases that may attack metals or solvents that affect polymeric materials.
Suitable precautions: e.g. regular checks as part of routine inspections or establishing from the material's data sheet that it is resistant to specific chemicals.
7. The Rosemount 2130 meets the requirements of clause 6.3.12 (Isolation of circuits from earth or frame) in EN 60079-11 (IEC 60079-11).
8. Technical Data

- a. Coding:
ATEX: II 1 G D, Ex ia IIC T5...T2 Ga,
Ex ia IIIC T85 °C...265 °C Da
IECEx: Ex ia IIC T5...T2 Ga, Ex ia IIIC T85 °C...265 °C Da
- b. Temperature:
See Table B-4 or Table B-5 (NAMUR electronics).
See Table B-6 or Table B-7 (8/16 mA electronics)
- c. Input parameters:
Rosemount 2130 with NAMUR electronics:
Vmax=15 V, Imax=32 mA, Pi=0.1 W, Ci=12 nF,
Li=0.06 mH
Rosemount 2130 with 8/16 mA electronics:
Vmax=30 V, Imax=93 mA, Pi=0.65 W, Ci=12 nF,
Li=0.035 mH
- d. Materials: see "Specifications" on page 39.
- e. Year of manufacture: printed on the product label.

Table B-4. High-temperature Rosemount 2130N (I1/I7)

2130N**E*****I1****,
2130N**E*****I7****:

Gas (Ga) and Dust (Da)			
Temperature Classes	Maximum Surface Temp. (T)	Maximum Ambient Air Temp. (Ta)	Maximum Process Temp. (Tp)
T5, T4, T3, T2, T1	T85 °C	80 °C	80 °C
T4, T3, T2, T1	T120 °C	77 °C	115 °C
T3, T2, T1	T190 °C	71 °C	185 °C
T2, T1	T265 °C	65 °C	260 °C

Minimum ambient air temperature (Ta) = -50 °C

Minimum process temperature (Tp) = -70 °C

Table B-5. Mid-temperature Rosemount 2130N (I1/I7)

2130N**M*****I1**** and
2130N**M*****I7****:

Gas (Ga) and Dust (Da)			
Temperature Classes	Maximum Surface Temp. (T)	Maximum Ambient Air Temp. (Ta)	Maximum Process Temp. (Tp)
T5, T4, T3, T2, T1	T85 °C	80 °C	80 °C
T4, T3, T2, T1	T120 °C	69 °C	115 °C
T3, T2, T1	T185 °C	50 °C	180 °C

Minimum ambient air temperature (Ta) = -50 °C

Minimum process temperature (Tp) = -40 °C

Table B-6. High-temperature Rosemount 2130M (I1/I7)

2130M**E*****I1**** and
2130M**E*****I7****:

Gas (Ga)		
Temperature Classes	Maximum Ambient Air Temperature (Ta)	Maximum Process Temperature (Tp)
T5, T4, T3, T2, T1	80 °C	80 °C
T4, T3, T2, T1	77 °C	115 °C
T3, T2, T1	71 °C	185 °C
T2, T1	65 °C	260 °C

Dust (Da)			
Temperature Classes	Maximum Surface Temp. (T)	Maximum Ambient Air Temp. (Ta)	Maximum Process Temp. (Tp)
T5, T4, T3, T2, T1	T85 °C	70 °C	80 °C
T4, T3, T2, T1	T120 °C	70 °C	115 °C
T3, T2, T1	T190 °C	70 °C	185 °C
T2, T1	T265 °C	65 °C	260 °C

Minimum ambient air temperature (Ta) = -50 °C

Minimum process temperature (Tp) = -70 °C

Table B-7. Mid-temperature Rosemount 2130M (I1/I7)

2130M**M*****I1**** and
2130M**M*****I7****:

Gas (Ga)		
Temperature Classes	Maximum Ambient Air Temp. (Ta)	Maximum Process Temp. (Tp)
T5, T4, T3, T2, T1	80 °C	80 °C
T4, T3, T2, T1	69 °C	115 °C
T3, T2, T1	50 °C	180 °C

Dust (Da)			
Temperature Classes	Maximum Surface Temp. (T)	Maximum Ambient Air Temp. (Ta)	Maximum Process Temp. (Tp)
T5, T4, T3, T2, T1	T85 °C	70 °C	80 °C
T4, T3, T2, T1	T120 °C	69 °C	115 °C
T3, T2, T1	T185 °C	50 °C	180 °C

Minimum ambient air temperature (Ta) = -50 °C

Minimum process temperature (Tp) = -40 °C

9. Special conditions of use:

- a. If the enclosure is made of an alloy or plastic material, the following precautions must be observed:
 - (i) The metallic alloy used for the enclosure material may be at the accessible surface of this equipment; in the event of rare accidents, ignition sources due to impact and friction sparks could occur. This shall be considered when the Rosemount 2130 is being installed in locations that specifically require Equipment Protection Level Ga or Da [ATEX: group II, category 1G or 1D equipment] [IECEx: in Zone 0 or 20 locations].
 - (ii) Under certain extreme circumstances, the non-metallic parts incorporated in the enclosure of the Rosemount 2130 may generate an ignition-capable level of electrostatic charge. Therefore, when they are used for applications that specifically require Equipment Protection Level Ga or Da [ATEX: group II, category 1G or 1D equipment] [IECEx: in Zone 0 or 20 locations], the Rosemount 2130 shall not be installed in a location where the external conditions are conducive to the build-up of electrostatic charge on such surfaces. Additionally, the Rosemount 2130 shall only be cleaned with a damp cloth.
- b. Ensure the ambient air temperature (Ta) and the process temperature (Tp) are within the range detailed above for the T class of the specific explosive gases or vapors present.

- c. Ensure the ambient air temperature (T_a) and the process temperature (T_p) are within the range detailed above for the maximum surface temperature of the specific explosive dusts present.

- 10. Manufacturer
Rosemount Measurement Limited, 158 Edinburgh Avenue,
Slough, Berkshire, SL1 4UE, United Kingdom.

Instructions specific to hazardous area installations (E1 and E7)

The following instructions apply to the Rosemount 2130 covered by certificates **Sira 05ATEX1129X** and **IECEx SIR 06.0051X**:

1. The equipment may be used with flammable gases and vapors with apparatus groups IIA, IIB, and IIC, and with temperature classes T1, T2, T3, T4, T5, and T6.
The temperature class of the installation will be determined from the higher of the process or ambient temperature.
2. The equipment may be used in a hazardous area with explosive dusts with apparatus groups IIIC, IIIB, and IIIA.
The maximum surface temperature of the installation will be determined from the higher of the process or ambient temperature.
3. The equipment is suitable for installation across the boundary between an area that specifically requires Equipment Protection Level Gb or Db (Zone 1 or 21).
The probe forks (and extension tube) only to be installed in Zone 0.
4. The equipment has not been assessed as a safety related device as referred to by Directive 94/9/EC (2014/3/EU) Annex II, clause 1.5.
5. Installation of this equipment shall be carried out by suitably trained personnel, in accordance with the applicable code of practice.
6. Inspection and maintenance of this equipment shall be carried out by suitably trained personnel, in accordance with the applicable code of practice.
7. The user should not repair this equipment. Repair or modification of flame paths is not permitted.
8. The certification of this equipment relies upon the following materials used in its construction:
Housing and cover:
Aluminum alloy (ASTM B85 360.0) or stainless steel 316L
Probe (partition wall):
Stainless steel 316L or 316/316L, or Alloy C276
(UNS N10276) and Alloy C (UNS N10002 or N30002)
Probe filling: Perlite
Cover seal: Silicone
9. If the equipment is likely to come into contact with aggressive substances, it is the responsibility of the user to take suitable precautions that prevent it from being adversely affected, thus ensuring that the type of protection is not compromised.

Aggressive substances: e.g. acidic liquids or gases that may attack metals, or solvents that may affect polymeric materials.

Suitable precautions: e.g. regular checks as part of routine inspections or establishing from the material's data sheet that it is resistant to specific chemicals.

10. It is the responsibility of the user to ensure:
 - a. The voltage and current limits for this equipment are not exceeded.
 - b. That the joint requirements between the probe and the vessel tank are compatible with the process media.
 - c. That the joint tightness is correct for the joint material used.
 - d. That only suitably certified cable entry devices will be utilized when connecting this equipment.
 - e. That any unused cable entries are sealed with suitably certified stopping plugs.
11. The probe fork is subjected to small vibration stresses as part of its normal function. As this provides a partition wall, it is recommended that the fork should be inspected every 2 years for signs of defects.
12. Technical data:
 - a. Coding:
ATEX:
II 1/2 G D,
Ex db IIC T6...T2 Ga/Gb
Ex tb IIIC T85 °C to T265 °C Db

IECEx:
Ex db IIC T6...T2 Ga/Gb
Ex tb IIIC T85 °C...T265 °C Db
 - b. Temperature: See [Table B-8](#) or [Table B-9](#).
 - c. Pressure: must not exceed the rating of the coupling/flange fitted.
 - d. For electrical details and pressure ratings, see "[Specifications](#)" on [page 39](#).
 - e. Year of manufacture: printed on the product label.
13. Special conditions of use
 - a. The user is to ensure the probe assembly is installed in such a way to prevent any damage due to impact or ignition source due to friction.
 - b. Under certain extreme conditions, a non-standard paint on the enclosure of the Rosemount 2130 may generate an ignition-capable level of electrostatic charge. Therefore, the Rosemount 2130 shall not be installed in a location where the external conditions are conducive to the build-up of electrostatic charge on such surfaces. Additionally, the Rosemount 2130 shall only be cleaned with a damp cloth.
 - c. The user is to ensure the ambient air temperature (T_a) and the process temperature (T_p) are within the range detailed above for the T class of the specific flammable gases or vapors present.

- d. The user is to ensure the ambient air temperature (Ta) and the process temperature (Tp) are within the range detailed above for the maximum surface temperature of the specific flammable dusts present.

Table B-8. High-temperature Rosemount 2130

2130*A2E*****E1****,
 2130*S2E*****E1****,
 2130*A2E*****E7****,
 2130*S2E*****E7****:

Temperature classes	Maximum surface temp. (T)	Maximum ambient air temp. (Ta)	Maximum process temp. (Tp)
T6, T5, T4, T3, T2, T1	T85 °C	75 °C	80 °C
T5, T4, T3, T2, T1	T100 °C	74 °C	95 °C
T4, T3, T2, T1	T120 °C	73 °C	115 °C
T3, T2, T1	T190 °C	69 °C	185 °C
T2, T1	T265 °C	65 °C	260 °C

Minimum ambient air temperature (Ta) = -40 °C

Minimum process temperature (Tp) = -70 °C

Table B-9. Mid-range Temperature Rosemount 2130

2130*A2M*****E1****,
 2130*S2M*****E1****,
 2130*A2M*****E7****,
 2130*S2M*****E7****:

Temperature classes	Maximum surface temp. (T)	Maximum ambient Air temp. (Ta)	Maximum process temp. (Tp)
T6, T5, T4, T3, T2, T1	T85 °C	75 °C	75 °C
T5, T4, T3, T2, T1	T100 °C	70 °C	90 °C
T4, T3, T2, T1	T135 °C	65 °C	125 °C
T3, T2, T1	T190 °C	50 °C	180 °C

Minimum ambient air temperature (Ta) = -40 °C

Minimum process temperature (Tp) = -40 °C

14. Cable selection

- a. It is the responsibility of the user to ensure that suitably temperature rated cable is used. Note that the cable entry temperature may exceed 70 °C. [Table B-10](#) is a guide to selection.

Table B-10. Cable Selection Guide (E1/E7)

T class	Cable temperature rating
T6	Above 85 °C
T5	Above 100 °C
T4	Above 135 °C
T3	Above 160 °C

Instructions specific to hazardous area installations (I3)

The 2130N*** Vibrating Fork Liquid Level Sensor (hereinafter, Level Switch in this section), manufactured by Rosemount Measurement Limited, Emerson Automated Solutions Asia Pacific Pte Ltd., and Rosemount Inc., has been certified by the National Supervision and Inspection Center for Explosion Protection and Safety of Instrumentation (NEPSI). The Level Switch accords with **GB 3836.1-2000** and **GB 3836.4-2000** standards.

Ex marking: **Ex ia IIC T5~T2**

Certificate: **GYJ101372X**

Special Conditions For Safe Use:

1. The “X” in the certificate number denotes specific conditions of use:
 - a. When the Level Switch is used with process mediums in excess of 80 °C, then the internal electronics temperature shall not exceed this value.
 - b. The metallic alloy used for the enclosure material may generate a spark if it is subject to friction or an impact.
 - c. To avoid an electrostatic charge, the non-metallic parts incorporated in the Level Switch enclosure shall only be cleaned with a damp cloth.
2. The relationship between temperature class, ambient temperature range, and process temperature range is as follows:

Table B-11. 2130N*M**

T code	Ambient temperature	Process temperature
T5	-50 to 80 °C	-40 to 80 °C
T4	-50 to 69 °C	-40 to 115 °C
T3	-50 to 50 °C	-40 to 180 °C

Table B-12. 2130E**

T code	Ambient temperature	Process temperature
T5	-50 to 80 °C	-70 to 85 °C
T4	-50 to 77 °C	-70 to 115 °C
T3	-50 to 71 °C	-70 to 185 °C
T2	-50 to 65 °C	-70 to 260 °C

3. Safety parameters:
Ui:15 V, Ii:32 mA, Pi:100 mW, Ci:12 nF, Li:60 μH
4. The Level Switch should be used with Ex-certified associated apparatus to establish an explosion protection system that can be used in explosive gas atmospheres. Wiring and terminal connections should comply with instructions in the manuals of the Level Switch and associated apparatus.
5. The cables between the Level Switch and associated apparatus should be shielded (screened). The cable screen has to be grounded reliably in a non-hazardous area.
6. Associated apparatus should be installed in a safe location. During installation, operation, and maintenance, the instruction manual should be strictly observed.
7. End users are not permitted to change any components inside. (See “Product recycling and disposal” on page 5 for contact information).
8. During installation, use, and maintenance of the Level Switch, the following standards are to be observed:
 - a. **GB3836.13-1997**
“Electrical apparatus for explosive gas atmosphere Part 13: Repair and overhaul for apparatus used in explosive gas atmosphere”.
 - b. **GB3836.15-2000**
“Electrical apparatus for explosive gas atmosphere Part 15: Electrical installations in hazardous area (other than mines)”.
 - c. **GB3836.16-2006**
“Electrical apparatus for explosive gas atmosphere Part 16: Inspection and maintenance of electrical installation (other than mines)”.
 - d. **GB50257-1996**
“Code for construction and acceptance of electric device for explosion atmospheres and fire hazard electrical equipment installation engineering”.

Instructions specific to hazardous area installations (E3)

The 2130**2* Vibrating Fork Liquid Level Sensor (hereinafter, Level Switch in this section), manufactured by Rosemount Measurement Limited, Emerson Automated Solutions Asia Pacific Pte Ltd., and Rosemount Inc., has been certified by the National Supervision and Inspection Center for Explosion Protection and Safety of Instrumentation (NEPSI).
The Level Switch accords with **GB 3836.1-2000**, **GB 3836.2-2000**, and **GB 12476.1-2000** standards.

Ex marking: **Ex d IIC T6~T2, DIP A21 T_A (T85 °C ~ 265 °C) IP6X**

Certificate: **GYJ101373**

Special Conditions For Safe Use:

1. The relationship between temperature class, ambient temperature range, and process temperature range is as follows:

Table B-13. 2130*M**

T code (T dust)	Ambient temperature	Process temperature
T6 (T85 °C)	-40 to 75 °C	-40 to 75 °C
T5 (T100 °C)	-40 to 70 °C	-40 to 90 °C
T4 (T135 °C)	-40 to 65 °C	-40 to 125 °C
T3 (T160 °C)	-40 to 50 °C	-40 to 180 °C

Table B-14. 2130*E**

T code	Ambient temperature	Process temperature
T6 (T85 °C)	-40 to 75 °C	-70 to 80 °C
T5 (T100 °C)	-40 to 74 °C	-70 to 95 °C
T4 (T120 °C)	-40 to 73 °C	-70 to 115 °C
T3 (T190 °C)	-40 to 69 °C	-70 to 185 °C
T2 (T265 °C)	-40 to 65 °C	-70 to 260 °C

2. The earth connection facility on the enclosure should be connected reliably.
3. During installation in a hazardous location, cable glands, conduits, and blanking plugs certified by state-appointed inspection bodies (for Ex d IIC DIP A21 T_A IP6X protection) should be used.
4. During installation, use, and maintenance in explosive gas atmospheres, observe the warning “Do not open when energized”. During installation, use, and maintenance in an explosive dust atmosphere, observe the warning “Do not open when an explosive dust atmosphere is present”.

5. End users are not permitted to change any components inside. (See “Product recycling and disposal” on page 5 for contact information).
6. Maintenance should be done in a non-hazardous location.
7. During installation, use, and maintenance of the Level Switch, the following standards are to be observed:
 - a. **GB3836.13-1997**
“Electrical apparatus for explosive gas atmosphere Part 13: Repair and overhaul for apparatus used in explosive gas atmosphere”.
 - b. **GB3836.15-2000**
“Electrical apparatus for explosive gas atmosphere Part 15: Electrical installations in hazardous area (other than mines)”.
 - c. **GB3836.16-2006**
“Electrical apparatus for explosive gas atmosphere Part 16: Inspection and maintenance of electrical installation (other than mines)”.
 - d. **GB50257-1996**
“Code for construction and acceptance of electric device for explosion atmospheres and fire hazard electrical equipment installation engineering”.
 - e. **GB15577-1995**
“Safe regulation for explosive dust atmospheres”.
 - f. **GB12476.2-2006**
“Electrical apparatus protected for use in the presence of combustible dust – Part 1-2: Electrical apparatus protected by enclosures and surface temperature limitation –Selection, installation, and maintenance”.

Global Headquarters

Emerson Automation Solutions

6021 Innovation Blvd.
Shakopee, MN 55379, USA
+1 800 999 9307 or +1 952 906 8888
+1 952 949 7001
RFQ.RMD-RCC@Emerson.com

North America Regional Office

Emerson Automation Solutions

8200 Market Blvd.
Chanhassen, MN 55317, USA
+1 800 999 9307 or +1 952 906 8888
+1 952 949 7001
RMT-NA.RCCRFQ@Emerson.com

Latin America Regional Office

Emerson Automation Solutions

1300 Concord Terrace, Suite 400
Sunrise, FL 33323, USA
+1 954 846 5030
+1 954 846 5121
RFQ.RMD-RCC@Emerson.com

Europe Regional Office

Emerson Automation Solutions Europe GmbH

Neuhofstrasse 19a P.O. Box 1046
CH 6340 Baar
Switzerland
+41 (0) 41 768 6111
+41 (0) 41 768 6300
RFQ.RMD-RCC@Emerson.com

Asia Pacific Regional Office

Emerson Automation Solutions Asia Pacific Pte Ltd

1 Pandan Crescent
Singapore 128461
+65 6777 8211
+65 6777 0947
Enquiries@AP.Emerson.com

Middle East and Africa Regional Office

Emerson Automation Solutions

Emerson FZE P.O. Box 17033
Jebel Ali Free Zone - South 2
Dubai, United Arab Emirates
+971 4 8118100
+971 4 8865465
RFQ.RMTMEA@Emerson.com

 [Linkedin.com/company/Emerson-Automation-Solutions](https://www.linkedin.com/company/Emerson-Automation-Solutions)

 [Twitter.com/Rosemount_News](https://twitter.com/Rosemount_News)

 [Facebook.com/Rosemount](https://www.facebook.com/Rosemount)

 [Youtube.com/user/RosemountMeasurement](https://www.youtube.com/user/RosemountMeasurement)

 [Google.com/+RosemountMeasurement](https://www.google.com/+RosemountMeasurement)

Standard Terms and Conditions of Sale can be found at:

www.Emerson.com/en-us/Terms-of-Use

The Emerson logo is a trademark and service mark of Emerson Electric Co.
Rosemount and Rosemount logotype are trademarks of Emerson.

NEMA is the registered trademark and service mark of the National Electrical Manufacturers Association

ROCKWOOL is a registered trademark of ROCKWOOL.

All other marks are the property of their respective owners.

© 2017 Emerson. All rights reserved.