

Rosemount® 148 Temperature Transmitter



Rosemount 148 Temperature Transmitter

Rosemount 148 Hardware Revision 5

NOTICE

Read this manual before working with the product. For personal and system safety, and for optimum product performance, make sure to thoroughly understand the contents before installing, using, or maintaining this product.

The United States has two toll-free assistance numbers and one international number:

Customer Central

1-800-999-9307 (7:00 a.m. to 7:00 p.m. CST)

National Response Center

1-800-654-7768 (24 hours a day)

Equipment service needs

International

1-952-906-8888

⚠ CAUTION

The products described in this document are NOT designed for nuclear-qualified applications.

Using non-nuclear qualified products in applications that require nuclear-qualified hardware or products may cause inaccurate readings.

For information on nuclear-qualified products, contact an Emerson Process Management Sales Representative.

Contents

Section 1: Introduction

1.1 Safety messages.....	1
1.1.1 Warnings	1
1.2 Overview	2
1.2.1 Manual	2
1.2.2 Transmitter	2
1.3 Considerations	3
1.3.1 General.....	3
1.3.2 Mechanical.....	3
1.3.3 Electrical.....	3
1.3.4 Environmental.....	3
1.4 Return of materials	5
1.5 Product Recycling/Disposal	5

Section 2: Installation

2.1 Safety messages.....	7
2.1.1 Warnings	7
2.2 Mounting.....	8
2.3 Installation.....	9
2.3.1 Typical European and Asia Pacific installation.....	10
2.3.2 Typical North and South American installation.....	11
2.4 Set the switches	11
2.4.1 Failure mode	11
2.5 Wiring.....	12
2.5.1 Sensor connections	13
2.6 Power supply.....	15
2.6.1 Surges/transients	15
2.6.2 Ground the transmitter.....	15

Section 3: Configuration

3.1 Safety messages.....	19
3.1.1 Warnings	19
3.2 Rosemount 148 PC Programmer	20
3.2.1 PC Programmer software installation.....	20
3.2.2 PC Programmer hardware setup	20
3.2.3 Configuring with the Rosemount 148 PC Programmer.....	21
3.2.4 Information	23

Section 4: Operation and Maintenance

4.1 Safety messages	25
4.1.1 Warnings	25
4.2 Hardware	26
4.2.1 Maintenance	26
4.2.2 Diagnostic messages	26

Appendix A: Specifications

A.1 Transmitter specifications	27
A.1.1 Functional specifications	27
A.1.2 Physical specifications	28
A.1.3 Performance specifications	29
A.2 Dimensional drawings	32
A.3 Ordering information	34

Appendix B: Product Certifications

B.1 Approved manufacturing locations	37
B.2 European directive information	37
B.3 Ordinary location certification from FM approvals	37
B.3.1 North America	37
B.3.2 Europe	38
B.3.3 International	39
B.3.4 Combinations	40
B.4 Tables	40

Section 1 Introduction

Safety messages	page 1
Overview	page 2
Considerations	page 3
Return of materials	page 5
Product recycling/disposal	page 5

1.1 Safety messages

Instructions and procedures in this section may require special precautions to ensure the safety of the personnel performing the operations. Information that potentially raises safety issues is indicated by a warning symbol . Please refer to the following safety messages before performing an operation preceded by this symbol.

1.1.1 Warnings

WARNING

Failure to follow these installation guidelines could result in death or serious injury:

- Make sure only qualified personnel perform the installation

Explosions could result in death or serious injury:

- Do not remove the connection head cover in explosive atmospheres when the circuit is live.
- Verify that the operating atmosphere of the transmitter is consistent with the appropriate hazardous locations certifications.
- All connection head covers must be fully engaged to meet explosion-proof requirements.

Process leaks could result in death or serious injury:

- Do not remove the thermowell while in operation.
- Install and tighten thermowells and sensors before applying pressure.

Electrical shock could cause death or serious injury:

- Use extreme caution when making contact with the leads and terminals.
-

1.2 Overview

1.2.1 Manual

This manual is designed to assist in the installation, operation, and maintenance of the Rosemount 148 Temperature Transmitter.

Section 1: Introduction

- Transmitter and Manual Overview
- Things to consider
- How to return the transmitter

Section 2: Installation

- How to mount the transmitter
- How to install the transmitter
- How to set the switches to ensure proper use
- How to wire and power up the transmitter

Section 3: Configuration

- Configuring the transmitter

Section 4: Operation and maintenance

- Explanation of hardware maintenance

Appendix A: Specifications

- Transmitter and sensor specifications
- Dimensional drawings
- Ordering information

Appendix B: Product Certifications

- Product Certifications/Hazardous Locations Certifications
- Installation drawings

1.2.2 Transmitter

Features of the Rosemount 148 include:

- Accepts inputs from a wide variety of RTD and thermocouple sensors
- Electronics that are completely encapsulated in epoxy and enclosed in a plastic housing, making the transmitter extremely durable and ensuring long-term reliability.
- A compact size and many housing options allow mounting flexibility in the field
- Model code option that allows it to be assembled to any sensor, thermowell, and extension accessory

Refer to the following literature for sensors and thermowells that can be assembled to the Rosemount 148. They include additional connection heads that may not be available in the Rosemount 148 model structure.

- Temperature Sensors and Accessories (English) Product Data Sheet (Document Number 00813-0100-2654)
- Temperature Sensors and Accessories (Metric) Product Data Sheet (Document Number 00813-0200-2654)
- Rosemount Series 1075 and 1099 High-Temperature Thermocouples Product Data Sheet (Document Number 00813-0400-2654)

1.3 Considerations

1.3.1 General

Electrical temperature sensors such as RTDs and thermocouples produce low-level signals proportional to the sensed temperature. The Rosemount 148 converts the low-level sensor signal to a standard 4–20 mA DC signal that is relatively insensitive to lead length and electrical noise. This current signal is transmitted to the control room via two wires.

1.3.2 Mechanical

Location

Take into account the need for access to the transmitter when choosing an installation location.

Special mounting

Special hardware is available for mounting a Rosemount 148 head mount transmitter to a DIN rail.

1.3.3 Electrical

Proper electrical installation is necessary to prevent errors due to sensor lead resistance and electrical noise. For best results, shielded cable should be used in electrically noisy environments.

Make wiring connections through the cable entry in the side of the connection head. Be sure to provide adequate clearance for cover removal.

1.3.4 Environmental

The transmitter electronics module is permanently sealed within the housing, resisting moisture and corrosive damage. Verify that the operating atmosphere of the transmitter is consistent with the appropriate hazardous locations certifications.

Temperature effects

The transmitter will operate within specifications for ambient temperatures between -40 °F and 185 °F (-40 °C and 85 °C). Heat from the process is transferred from the thermowell to the transmitter housing. If the expected process temperature is near or above specification limits, consider using additional thermowell lagging, and extension nipple, or a remote mounting configuration to isolate the transmitter from the process.

Figure 1-1 provides an example of the relationship between transmitter housing temperature rise and extension length.

Figure 1-1. Rosemount 148 transmitter connection head temperature rise vs. Extension length.

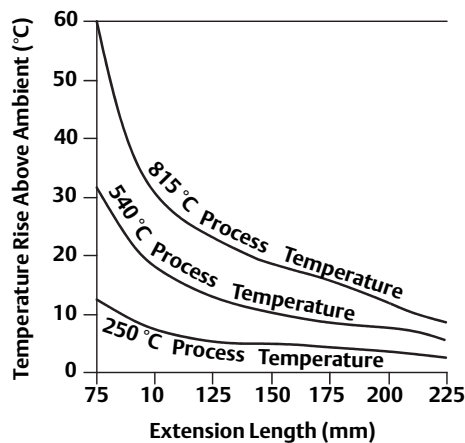

Example

The transmitter specification limit is 85 °C. If the ambient temperature is 55 °C and the process temperature to be measured is 800 °C, the maximum permissible connection head temperature rise is the transmitter specification limit minus the ambient temperature (moves 85 °C to 55 °C), or 30 °C.

In this case, an extension of 100 mm meets this requirement, but 125 mm provides a margin of 8 °C, thereby reducing any temperature effects in the transmitter.

1.4 Return of materials

To expedite the return process in North America, call the Emerson Process Management National Response Center toll-free at 800-654-7768. This center, available 24 hours a day, can assist with any needed information or materials.

The center will ask for the following information:

- Product model
- Serial numbers
- The last process material to which the product was exposed

The center will provide:

- A Return Material Authorization (RMA) number
- Instructions and procedures that are necessary to return goods that were exposed to hazardous substances

Note

If a hazardous substance is identified, a Material Safety Data Sheet (MSDS), required by law to be available to people exposed to specific hazardous substances, must be included with the returned materials.

Outside of North America, contact a local Emerson Process Management representative.

1.5 Product recycling/disposal

Recycling of equipment and packaging should be taken into consideration and disposed of in accordance with local and national legislation/regulations.

Section 2 Installation

Safety messages	page 7
Mounting	page 8
Installation	page 9
Set the switches	page 11
Wiring	page 11
Power supply	page 15

2.1 Safety messages

Instructions and procedures in this section may require special precautions to ensure the safety of the personnel performing the operations. Information that potentially raises safety issues is indicated by a warning symbol . Please refer to the following safety messages before performing an operation preceded by this symbol.

2.1.1 Warnings

WARNING

Failure to follow these installation guidelines could result in death or serious injury:

- Make sure only qualified personnel perform the installation.

Explosions could result in death or serious injury:

- Do not remove the connection head cover in explosive atmospheres when the circuit is live.
- Before connecting a communicator in an explosive atmosphere, make sure the instruments in the loop are installed in accordance with intrinsically safe or non-incendive field wiring practices.
- Verify that the operating atmosphere of the transmitter is consistent with the appropriate hazardous locations certifications.
- All connection head covers must be fully engaged to meet explosion-proof requirements.

Process leaks could result in death or serious injury:

- Do not remove the thermowell while in operation.
- Install and tighten thermowells and sensors before applying pressure.

Electrical shock could cause death or serious injury:

- Use extreme caution when making contact with the leads and terminals.
-

Figure 2-1. Installation flowchart

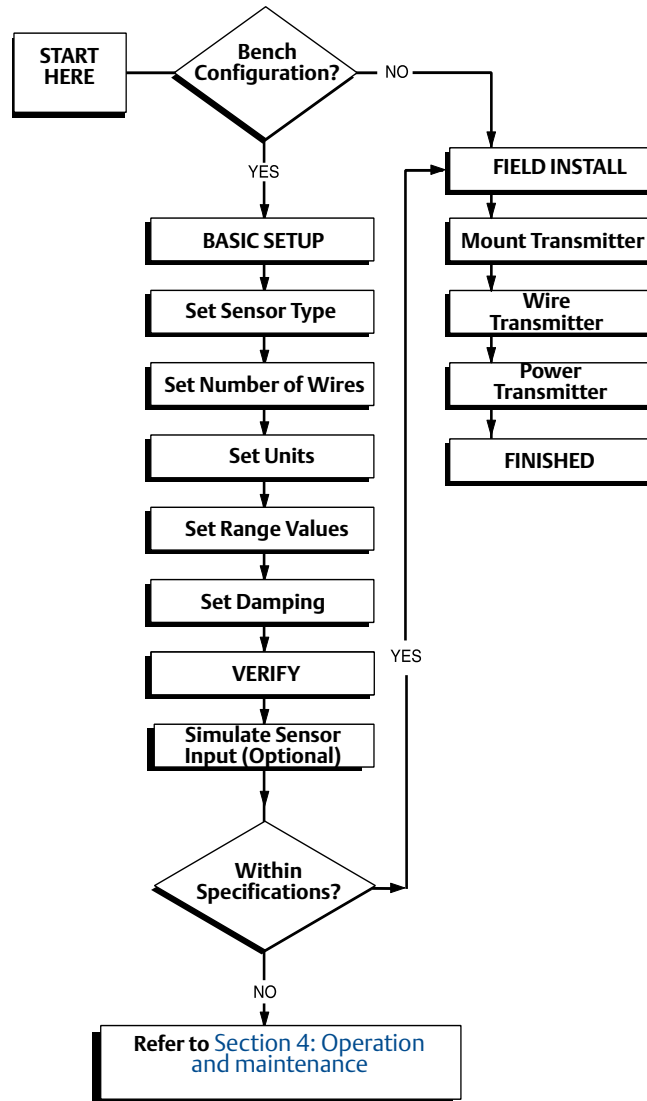

2.2 Mounting

Mount the transmitter at a high point in the conduit run to prevent moisture from draining into the transmitter housing.

The Rosemount 148 installs:

- In a connection head or universal head mounted directly on a sensor assembly
- Apart from a sensor assembly using a universal head
- To a DIN rail using an optional mounting clip

Mounting a Rosemount 148 to a DIN Rail

To attach a head mount transmitter to a DIN rail, assemble the appropriate rail mounting kit (Part Number 00248-1601-0001) to the transmitter as shown in [Figure 2-2](#).

Figure 2-2. Assembling rail clip hardware to a Rosemount 148.

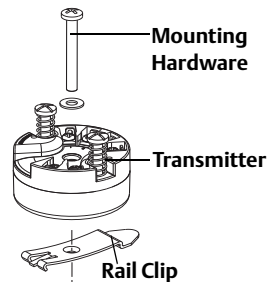

2.3 Installation

The Rosemount 148 can be ordered assembled to a sensor with the XA option code and thermowell or as a stand-alone unit. If ordered without the sensor assembly, use the following guidelines when installing the transmitter with an integral sensor assembly.

2.3.1 Typical European and Asia Pacific installation

Transmitter with DIN plate style sensor

1. ⚠ Attach the thermowell to the pipe or process container wall. Install and tighten the thermowell before applying process pressure.
2. Assemble the transmitter to the sensor. Push the transmitter mounting screws through the sensor mounting plate and insert the snap rings (optional) into the transmitter mounting screw groove.
3. Wire the sensor to the transmitter (see [Figure 2-6 on page 13](#)).
4. Insert the transmitter-sensor assembly into the connection head. Thread the transmitter mounting screw into the connection head mounting holes. Assemble the extension to the connection head. Insert the assembly into the thermowell.
5. Slip the shielded cable through the cable gland.
6. Attach a cable gland into the shielded cable.
7. Insert the shielded cable leads into the connection head through the cable entry. Connect and tighten the cable gland.
8. ⚠ Connect the shielded power cable leads to the transmitter power terminals. Avoid contact with sensor leads and sensor connections. (See [“Ground the transmitter” on page 15](#) for instructions on grounding the shield wire.)
9. ⚠ Install and tighten the connection head cover. Enclosure covers must be fully engaged to meet explosion-proof requirements.

Figure 2-3. Typical European and Asia Pacific installation

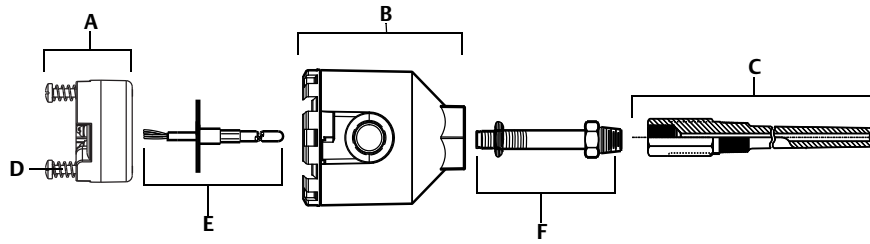

- A . Rosemount 148 Transmitter
- B . Connection Head
- C . Thermowell
- D . Transmitter Mounting Screws
- E . Integral Mount Sensor with Flying Leads
- F . Extension

2.3.2 Typical North and South American installation

Transmitter with threaded sensor



1.  Attach the thermowell to the pipe or process container wall. Install and tighten thermowells before applying process pressure.
2. Attach necessary extension nipples and adapters to the thermowell. Seal the nipple and adapter threads with silicone tape.
3. Turn the sensor into the thermowell until it is secure. Install drain seals if required for severe environments or to satisfy code requirements.
4. Pull the sensor wiring leads through the universal head and transmitter. Mount the transmitter in the universal head by threading the transmitter mounting screws into the universal head mounting holes.
5. Mount the transmitter-sensor assembly into the thermowell. Seal adapter threads with silicon tape.
6. Install conduit for field wiring to the conduit entry of the universal head. Seal conduit threads with silicon tape.
7.  Pull the field wiring leads through the conduit into the universal head. Attach the sensor and power leads to the transmitter. Avoid contact with other terminals.
8.  Install and tighten the universal head cover. Enclosure covers must be fully engaged to meet explosion-proof requirements.

Figure 2-4. Typical North and South American installation



- A . Threaded Thermowell
- B . Threaded Style Sensor
- C . Standard Extension
- D . Universal Head
- E . Conduit Entry

2.4 Set the switches

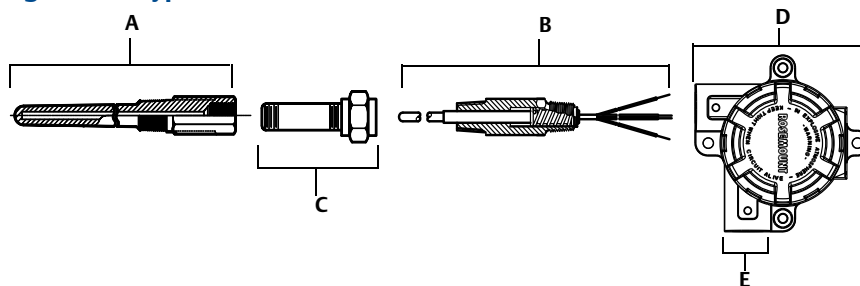
2.4.1 Failure mode

As part of normal operation, each transmitter continuously monitors its own performance. This automatic diagnostics routine is a timed series of checks repeated continuously. If diagnostics detect an input sensor failure or a failure in the transmitter electronics, the transmitter drives its output to low or high alarm depending on the failure mode configuration. If the sensor (process) temperature value is out of range, the transmitter outputs default saturation values. Low end saturation levels are either 3.90 or 3.80 mA and the high end saturation level is 20.5 mA. Corresponding NAMUR compliant operation levels are 3.80 and 20.5 mA. These values are also custom configurable by the factory or using the Rosemount 148 PC Programmer interface. See “Section 3: Configuration” on page 19 for instructions on how to change the alarm and saturation levels with the 148 PC Programmer.

Note

Microprocessor failures cause high alarm regardless of alarm direction (high or low) choice.

The values to which the transmitter drives its output in failure mode depend on whether it is configured to standard, NAMUR-compliant, or custom operations. See (★) for standard and NAMUR-compliant operation parameters.

2.5 Wiring

- ⚠ All power to the transmitter is supplied over the signal wiring. Use ordinary copper wire of sufficient size to ensure that the voltage across the transmitter power terminals does not drop below 12.0 V DC. Verify that the operating atmosphere of the transmitter is consistent with the appropriate hazardous locations certifications. Use extreme caution when making contact with the leads and terminals.
- ⚠ If the sensor is installed in a high-voltage environment and a fault condition or installation error occurs, the sensor leads and transmitter terminals could carry lethal voltages. Use extreme caution when making contact with the leads and terminals.

Note

- ⚠ Do not apply high voltage (e.g., AC line voltage) to the transmitter terminals, since abnormally high voltage can damage the unit. Sensor and transmitter power terminals are rated to 42.4 V DC). Use extreme caution when making contact with the leads and terminals.

The transmitters will accept inputs from a variety of RTD and thermocouple types. Refer to [Figure 2-6 on page 13](#) when making sensor connections.

Use the following steps to wire the transmitter:

1. Remove the terminal block cover, if applicable.
- ⚠ 2. Connect the positive power lead to the “+” terminal. Connect the negative power lead to the “-” terminal. See [Figure 2-5 on page 12](#). Use extreme caution when making contact with the leads and terminals.
3. Tighten the terminal screws.
- ⚠ 4. Reattach and tighten the cover, if applicable. All connection head covers must be fully engaged to meet explosion-proof requirements.
5. Apply power (see “Power supply”)

Figure 2-5. Rosemount 148 Wiring

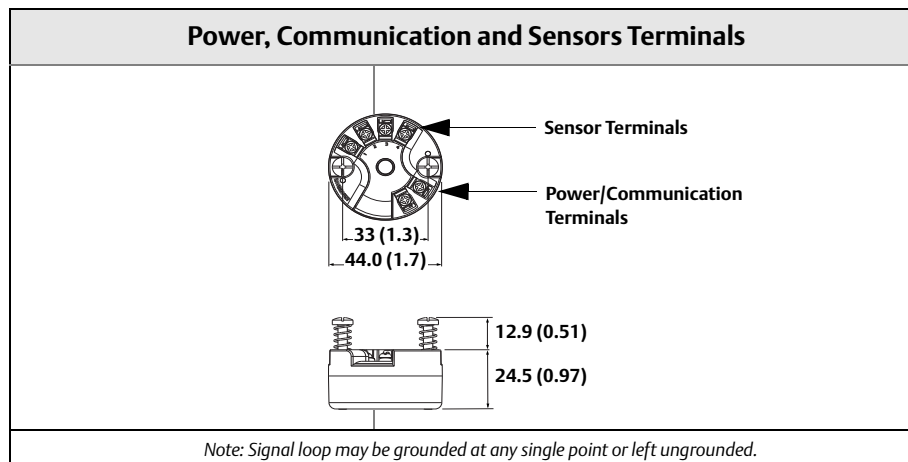

2.5.1 Sensor connections

- ⚠ The Rosemount 148 is compatible with a number of RTD and thermocouple sensor types. [Figure 2-6](#) shows the correct input connections to the sensor terminals on the transmitter. To ensure a proper sensor connection, anchor the sensor lead wires into the appropriate compression terminals and tighten the screws. Use extreme caution when making contact with the leads and terminals.

Figure 2-6. Sensor wiring diagrams

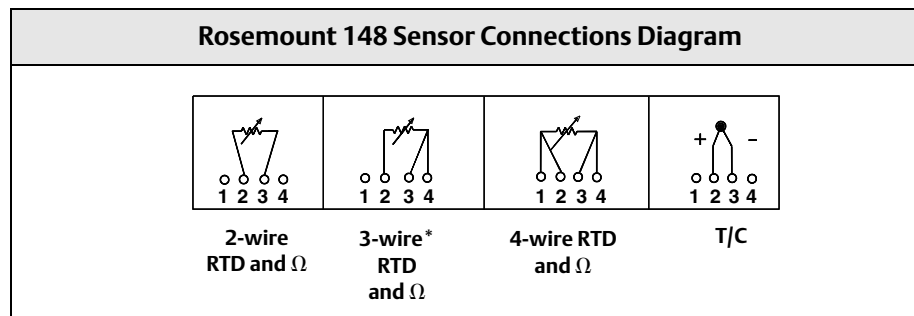

** Emerson Process Management provides 4-wire sensors for all single element RTDs. Use these RTDs in 3-wire configurations by leaving the unneeded leads disconnected and insulated with electrical tape.*

Thermocouple

The thermocouple can be connected directly to the transmitter. Use appropriate thermocouple extension wire if mounting the transmitter remotely from the sensor.

RTD or ohm inputs

The Rosemount 148 will accept a variety of RTD configurations, including 2-wire, 3-wire, and 4-wire designs. If the transmitter is mounted remotely from a 3-wire or 4-wire RTD, it will operate within specifications, without recalibration, for lead wire resistances of up to 60 ohms per lead (equivalent to 6,000 feet of 20 AWG wire). In this case, the leads between the RTD and transmitter should be shielded. If using only two leads, both RTD leads are in series with the sensor element, so significant errors can occur if the lead lengths exceed three feet of 20 AWG wire (approximately 0.05 °C/ft). For longer runs, attach a third or fourth lead as described above.

Sensor lead wire resistance effect - RTD input

When using a 4-wire RTD, the effect of lead resistance is eliminated and has no impact on accuracy. However, a 3-wire sensor will not fully cancel lead resistance error because it cannot compensate for imbalances in resistance between the lead wires. Using the same type of wire on all three lead wires will make a 3-wire RTD installation as accurate as possible. A 2-wire sensor will produce the largest error because it directly adds the lead wire resistance to the sensor resistance. For 2- and 3-wire RTDs, an additional lead wire resistance error is induced with ambient temperature variations. The table and the examples shown below help quantify these errors.

Table 2-1. Examples of approximate basic error.

Sensor input	Approximate basic error
4-wire RTD	None (independent of lead wire resistance)
3-wire RTD	± 1.0 Ω in reading per ohm of unbalanced lead wire resistance (Unbalanced lead wire resistance = maximum imbalance between any two leads.)
2-wire RTD	1.0 Ω in reading per ohm of lead wire resistance

Examples of approximate lead wire resistance effect calculations

Given:

Total cable length:	150 m
Imbalance of the lead wires at 20 °C:	0.5 Ω
Resistance/length (18 AWG Cu):	0.025 Ω/m °C
Temperature coefficient of Cu (α_{Cu}):	0.039 Ω/Ω °C
Temperature coefficient of Pt (α_{Pt}):	0.00385 Ω/Ω °C
Change in Ambient Temperature (ΔT_{amb}):	25 °C
RTD Resistance at 0 °C (R_0):	100 Ω (for Pt 100 RTD)

- Pt100 4-wire RTD: No lead wire resistance effect.
- Pt100 3-wire RTD:

$$\text{Basic Error} = \frac{\text{Imbalance of Lead Wires}}{(\alpha_{Pt} \times R_0)}$$

$$\text{Error due to amb. temp. variation} = \frac{(\alpha_{Cu}) \times (\Delta T_{amb}) \times (\text{Imbalance of Lead Wires})}{(\alpha_{Pt}) \times (R_0)}$$

Lead wire imbalance seen by the transmitter = 0.5 Ω

$$\text{Basic error} = \frac{0.5 \Omega}{(0.00385 \Omega / \Omega \text{ } ^\circ\text{C}) \times (100 \Omega)} = 1.3 \text{ } ^\circ\text{C}$$

$$\begin{aligned} \text{Error due to amb. temp. var. of } \pm 25 \text{ } ^\circ\text{C} \\ = \frac{(0.0039 \Omega / \Omega \text{ } ^\circ\text{C}) \times (25 \text{ } ^\circ\text{C}) \times (0.5 \Omega)}{(0.00385 \Omega / \Omega \text{ } ^\circ\text{C}) \times (100 \Omega)} = \pm 0.13 \text{ } ^\circ\text{C} \end{aligned}$$

- Pt100 2-wire RTD:

$$\text{Basic Error} = \frac{\text{Lead Wire Resistance}}{(\alpha_{Pt} \times R_0)}$$

$$\text{Error due to amb. temp. variation} = \frac{(\alpha_{Cu}) \times (\Delta T_{amb}) \times (\text{Lead Wire Resistance})}{(\alpha_{Pt}) \times (R_0)}$$

Lead wire resistance seen by the transmitter = 150 m × 2 wires × 0.025 Ω/m = 7.5 Ω

$$\text{Basic error} = \frac{7.5 \Omega}{(0.00385 \Omega / \Omega \text{ } ^\circ\text{C}) \times (100 \Omega)} = 19.5 \text{ } ^\circ\text{C}$$

$$\begin{aligned} \text{Error due to amb. temp. var. of } \pm 25 \text{ } ^\circ\text{C} \\ = \frac{(0.0039 \Omega / \Omega \text{ } ^\circ\text{C}) \times (25 \text{ } ^\circ\text{C}) \times (7.5 \Omega)}{(0.00385 \Omega / \Omega \text{ } ^\circ\text{C}) \times (100 \Omega)} = \pm 1.9 \text{ } ^\circ\text{C} \end{aligned}$$

2.6 Power supply

The power supplied to the transmitter should not drop below the transmitter lift-off voltage of 12 V DC.

2.6.1 Surges/transients

The transmitter will withstand electrical transients of the energy level encountered in static discharges or induced switching transients. However, high-energy transients, such as those induced in wiring from nearby lightning strikes, welding, heavy electrical equipment, or switching gears, can damage both the transmitter and the sensor. To protect against high-energy transients, install the transmitter into a suitable connection head with the Rosemount 470 Transient Protector. Refer to the Rosemount 470 Transient Protector Product Data Sheet (Document Number 00813-0100-4191) for further information.

2.6.2 Ground the transmitter

The transmitter will operate with the current signal loop either floating or grounded. However, the extra noise in floating systems affects many types of readout devices. If the signal appears noisy or erratic, grounding the current signal loop at a single point may solve the problem. The best place to ground the loop is at the negative terminal of the power supply. Do not ground the current signal loop at more than one point.

The transmitter is electrically isolated at 500 V AC rms (707 V DC) at 50/60 Hz, so the input circuit may also be grounded at any single point. When using a grounded thermocouple, the grounded junction serves as this point.

Note

Do not ground the signal wire at both ends.

Ungrounded thermocouple, and RTD/ohm inputs

Each process installation has different requirements for grounding. Use the grounding options recommended by the facility for the specific sensor type, or begin with grounding Option 1 (the most common).

Option 1:

1. Connect sensor wiring shield to the transmitter housing (only if the housing is grounded).
2. Ensure the sensor shield is electrically isolated from surrounding fixtures that may be grounded.
3. Ground signal wiring shield at the power supply end.

Figure 2-7. Grounded housing option (most common)

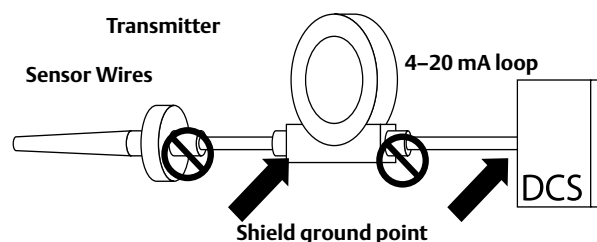

Option 2 (for ungrounded housing):

1. Connect signal wiring shield to the sensor wiring shield.
2. Ensure the two shields are tied together and electrically isolated from the transmitter housing.
3. Ground shield at the power supply end only.
4. Ensure that the sensor shield is electrically isolated from the surrounding grounded fixtures.

Figure 2-8. Ungrounded housing

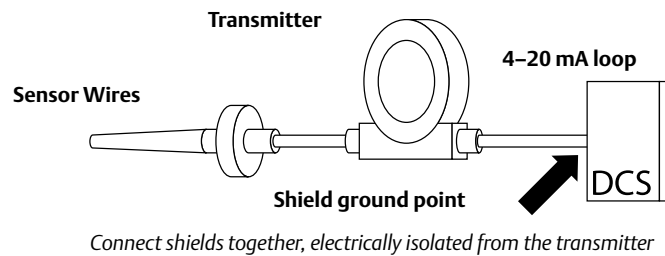

Option 3:

1. Ground sensor wiring shield at the sensor, if possible.
2. Ensure that the sensor wiring and signal wiring shields are electrically isolated from the transmitter housing.
3. Do not connect the signal wiring shield to the sensor wiring shield.
4. Ground signal wiring shield at the power supply end.

Figure 2-9. Ground sensor wiring

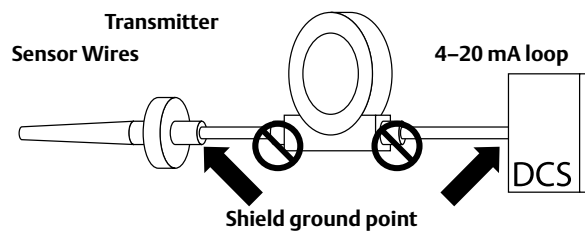

Grounded thermocouple inputs

Option 4:

1. Ground sensor wiring shield at the sensor.
2. Ensure that the sensor wiring and signal wiring shields are electrically isolated from the transmitter housing.
3. Do not connect the signal wiring shield to the sensor wiring shield.
4. Ground signal wiring shield at the power supply end.

Figure 2-10. Grounded thermocouple input option

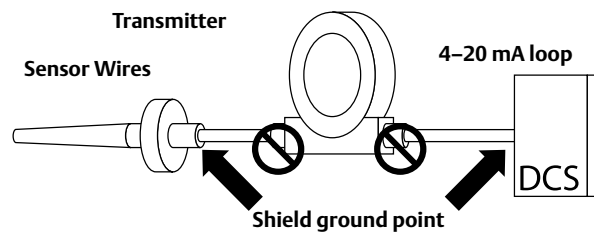

Section 3 Configuration

Safety messages	page 19
Rosemount 148 PC Programmer	page 20

3.1 Safety messages

Instructions and procedures in this section may require special precautions to ensure the safety of the personnel performing the operations. Information that potentially raises safety issues is indicated by a warning symbol (⚠). Please refer to the following safety messages before performing an operation preceded by this symbol.

3.1.1 Warnings

WARNING

Failure to follow these installation guidelines could result in death or serious injury:

- Make sure only qualified personnel perform the installation.

Explosions could result in death or serious injury:

- Do not remove the connection head cover in explosive atmospheres when the circuit is live.
- Before connecting a communicator in an explosive atmosphere, make sure the instruments in the loop are installed in accordance with intrinsically safe or non-incendive field wiring practices.
- When sending or requesting data that would disrupt the loop or change the output of the transmitter, set the process application loop to manual.
- Verify that the operating atmosphere of the transmitter is consistent with the appropriate hazardous locations certifications.
- All connection head covers must be fully engaged to meet explosion-proof requirements.

Process leaks could result in death or serious injury:

- Do not remove the thermowell while in operation.
- Install and tighten thermowells and sensors before applying pressure

Electrical shock could cause death or serious injury:

- Use extreme caution when making contact with the leads and terminals.
-

3.2 Rosemount 148 PC Programmer

The Rosemount 148 must be configured for certain basis variables to operate. In many cases, all of these variables are pre-configured at the factory. Configuration may be required if the transmitter is not configured or if the configuration variables need revision.

Configuration consists of testing the transmitter and verifying transmitter configuration data. The Rosemount 148 must be configured before installation. This can be done two ways: ordering factory-configuration by Emerson, or using the Rosemount 148 PC Programmer interface in a bench configuration setting.

3.2.1 PC Programmer software installation

The Rosemount 148 PC Programmer exchanges information with the transmitter in a bench configuration setting through a personal computer and interface box. See below for detailed instructions on installing the programming software.

1. Install the Rosemount 148 PC Programmer software.
 - Place the Rosemount 148 PC Programmer CD_ROM into the drive
 - Run setup.exe from Windows NT, 2000, or XP
2. When first using the Rosemount 148 PC software, configure the appropriate COM ports by choosing **Port Settings** from the *Communicate* menu.
3. Install MACTek Modem drivers completely before beginning bench configuration on the Rosemount 148 system.

Note

The software defaults to the first available COM port.

3.2.2 PC Programmer hardware setup

The Rosemount 148 PC Programming Kit includes configuration software and a communication modem. The Rosemount 148 device will need an external power supply of 12-42.4 Vdc for configuration.

1. Hook up the transmitter and a load resistor (250 - 1100 ohms) wired in series with the power supply.
2. Attach the Modem in parallel with the load resistor and connect it to the PC.

Please see [Table 3-1](#) for Spares Kit and re-order numbers.

Table 3-1. Rosemount 148 Programming Kit spare part numbers

Product description	Part number
Programming Software (CD)	00148-1601-0002
Rosemount 148 Programmer Kit - USB	00148-1601-0003
Rosemount 148 Programmer Kit - Serial	00148-1601-0004

The device can be configured from the main screen, and will also show the current transmitter status. The following pages detail the settings that can be configured on the Rosemount 148.

3.2.3 Configuring with the Rosemount 148 PC Programmer

In order to operate properly, the Rosemount 148 has basic variables that need to be configured. Some of the variables are factory configured, however, some of the variables may need to be initially set up or revised. The first two tabs on the main screen are Basic and Advanced Settings, which include all of the configuration variables that can be set for the Rosemount 148. Any changes to the configuration must be sent to the transmitter by clicking the Send to Transmitter button on the right of the screen. The current configuration of the connected 148 may be viewed by clicking the Load From Transmitter button.

Transmitter identification

The Tag variable is the easiest way to identify/distinguish between transmitters. It can be used to label transmitters electronically according to the requirements of the application. The tag may be up to eight characters in length, and does not impact the measurement of the transmitter.

Sensor configuration

The following sensors indicate the sensor type and the number of wires to be connected:

- 2-, 3-, or 4-wire Pt 100: $\alpha = 0.00385 \Omega/^\circ\text{C}$
- 2-, 3-, or 4-wire Pt 100: $\alpha = 0.003916 \Omega/^\circ\text{C}$
- 2-, 3-, or 4-wire Ni 120 nickel RTDs
- 2-, 3-, or 4-wire Cu 10 RTDs
- IEC/NIST/DIN Type B, J, K, N, R, S Thermocouples
- 2-, 3-, or 4-wire 0 - 2000 ohms

A complete line of temperature sensors, thermowells, and accessory mounting hardware is available from Emerson Process Management.

Output configuration

The Output Configuration area allows the user to set the desired measurement values for the transmitter:

- Degrees Celsius
- Degrees Fahrenheit
- Degrees Rankine
- Kelvin
- Ohms
- Millivolts

The 4 mA and 20 mA measurement point will need to be set to determine the analog output based on the temperature reading.

The Lower and Upper Range Limit of the sensor type selected above can also be viewed.

Damping

The Damping value changes the response time of the transmitter to smooth variations in the readings caused by rapid changes in input. Determine the appropriate damping setting based on the necessary response time, signal stability, and other requirements of the loop dynamics of the system. The default damping value is 5.0 seconds and can be reset to any value between 0 and 32 seconds.

The value chosen for damping affects the response time of the transmitter. When set to zero (or disabled), the damping function is off and the transmitter output reacts to changes in input as quickly as the intermittent sensor algorithm allows (refer to “*”) for a description of the intermittent sensor algorithm. Increasing the damping value increases the transmitter response time.

With damping enabled, the transmitter outputs values according to the following relationship. At time t

Damping Value =

$$P + (N - P) \times \left(1 - e^{-\frac{t}{T}} \right)$$

P = previous damped value
 N = new sensor value
 T = damping time constant
 U = update rate

At the time which the damping time constant is set, the transmitter output is at 63% of the input changes and it continues to approach the input according to the damping equation above.

After one damping time constant following a sensor input step change, the transmitter output will be 63.2% of that change. The output will continue to approach the input according to the damping equation above.

For example, as illustrated in *, if the temperature undergoes a step change from 100 ° to 100 °, and the damping is set to 5.0 seconds, the transmitter calculates and reports a new reading using the damping equation. At 5.0 seconds, the transmitter outputs 106.3 °, or 63.2% of the input change, and the output continues to approach the input curve according to the above equation.

Figure 3-1. Change in input vs. Change in output with Damping set to five seconds

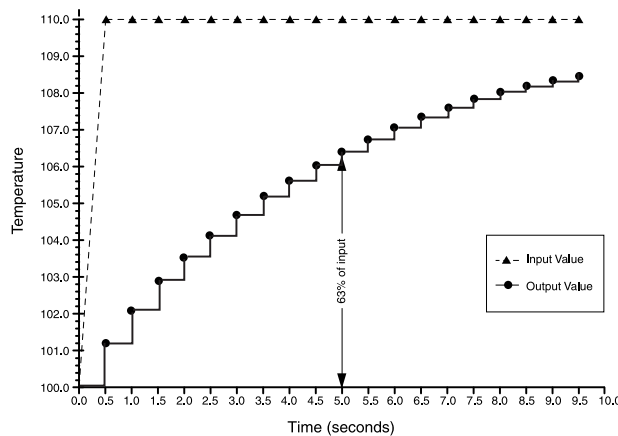

Alarm and saturation

Alarm Direction, Low Alarm Level, High Alarm Level, Low Saturation, and High Saturation values can be set here. Rosemount and NAMUR standard values can be found on [Table A-1](#) * or user-configured values may be entered. The guidelines are as follows:

- Low Alarm value must be between 3.50 and 3.75 mA
- High Alarm value must be between 21.0 and 23.0 mA
- Low Saturation level must be between the Low Alarm value plus 0.1 mA and 3.9 mA.
Example: The Low Alarm value has been set to 3.7 mA, so the Low Saturation level (S) must be 3.8 - 3.9 mA.
- The High Saturation level must be between 20.5 mA and the High Alarm value minus 0.1 mA. *Example: The High Alarm value has been set to 20.8 mA, so the Low Saturation level (S) must be 20.5 - 20.7 mA.*

See “[Failure mode](#)” for Failure Mode considerations.

50/60 Hz selection

The 50/60 Hz Selection sets the transmitter electronic filter to reject the frequency of the AC power supply in the plant.

Write protect

Write Protect safeguards the transmitter configuration data from accidental or unwarranted changes.

3.2.4 Information

The transmitter information tab can be selected from the main stat up screen, and lists the transmitter information variables that can be viewed. The Refresh button must be clicked to update the view of the current state of the transmitter.

Sensor temperature

The sensor temperature readings are displayed in the units set in the Basic Settings.

Analog output (mA)

Displays the transmitter output, read by the host system, in milliamperes.

Transmitter temperature

Shows the reading used by the onboard RTD to compensate the cold junction of thermocouples.

Status indicator buttons

Two buttons that indicate if the device is in Sensor Malfunction or Transmitter Malfunction.

Device identification

This shows revisions for the Software, Hardware and Final Assembly Number.

Section 4 Operation and Maintenance

Safety messages	page 25
Hardware	page 26

4.1 Safety messages

Instructions and procedures in this section may require special precautions to ensure the safety of the personnel performing the operations. Information that potentially raises safety issues is indicated by a warning symbol (⚠). Please refer to the following safety messages before performing an operation preceded by this symbol.

4.1.1 Warnings

WARNING

Failure to follow these installation guidelines could result in death or serious injury:

- Make sure only qualified personnel perform the installation.

Explosions could result in death or serious injury:

- Do not remove the connection head cover in explosive atmospheres when the circuit is live.
- Before connecting a Field Communicator in an explosive atmosphere, make sure the instruments in the loop are installed in accordance with intrinsically safe or non-incendive field wiring practices.
- When sending or requesting data that would disrupt the loop or change the output of the transmitter, set the process application loop to manual.
- Verify that the operating atmosphere of the transmitter is consistent with the appropriate hazardous locations certifications.
- All connection head covers must be fully engaged to meet explosion-proof requirements.

Process leaks could result in death or serious injury:

- Do not remove the thermowell while in operation.
- Install and tighten thermowells and sensors before applying pressure

Electrical shock could cause death or serious injury:

- Use extreme caution when making contact with the leads and terminals.
-

4.2 Hardware

The Rosemount 148 has no moving parts and requires minimal scheduled maintenance.

4.2.1 Maintenance

Sensor checkout

- ⚠ To determine whether the sensor is at fault, replace it with another sensor or connect a test sensor locally at the transmitter to test remote sensor wiring. Do not remove the thermowell while in operation. Select any standard, off-the-shelf sensor for use with a Rosemount 148 or consult the factory for a replacement special sensor and transmitter combination.

4.2.2 Diagnostic messages

If a malfunction is suspected, follow the procedures described in [Table 4-1](#) to verify that transmitter hardware and process connections are in good working order. Under each of the three major symptoms, specific suggestions are offered for solving the problem.

Table 4-1. Rosemount 148 troubleshooting chart

Symptom	Potential source	Corrective action
High Output	Sensor Input Failure or Connection	<ul style="list-style-type: none"> Check for a sensor open or short circuit. Check the process variable to see if it is out of range.
	Loop Wiring	<ul style="list-style-type: none"> Check for dirty or defective terminals, interconnecting pins, or receptacles.
	Power Supply	<ul style="list-style-type: none"> Check the output voltage of the power supply at the transmitter terminals. It should be 12.0 to 42.4 V dc (over entire 3.75 to 23 mA operating range).
Erratic Output	Loop Wiring	<ul style="list-style-type: none"> Check for adequate voltage to the transmitter. It should be 12.0 to 42.4 V dc at the transmitter terminals (over entire 3.75 to 23 mA operating range). Check for intermittent shorts, open circuits, and multiple grounds.
Low Output or No Output	Sensor Element	<ul style="list-style-type: none"> Check the process variable to see if it is out of range.
	Loop Wiring	<ul style="list-style-type: none"> Check for adequate voltage to the transmitter. It should be 12.0 to 42.4 V dc (over entire 3.75 to 23 mA operating range). Check for shorts and multiple grounds. Check for proper polarity at the signal terminal. Check the loop impedance. Check wire insulation to detect possible shorts to ground.

Appendix A Specifications

Transmitter specifications	page 27
Dimensional drawings	page 32
Ordering information	page 34

A.1 Transmitter specifications

A.1.1 Functional specifications

Inputs

User-selectable. See “Transmitter accuracy and ambient temperature effects ” for sensor options.

Outputs

2-wire 4–20 mA, linear with temperature or input.

Isolation

Input/output isolation tested to 500 V AC rms (707 V DC) at 50/60 Hz.

Power supply

An external power supply is required. The transmitter operates on 12.0 to 42.4 V DC transmitter terminal voltage.

Humidity limits

0 - 95% relative humidity, non-condensing

NAMUR recommendations

The Rosemount 148 meets the following NAMUR recommendations:

- NE 21 - Electromagnetic compatibility (EMC) for Process and Laboratory Apparatus
- NE 43 - Standard of the signal level breakdown information of digital transmitters

Transient protection

The optional Rosemount 470 prevents damage from transients induced by lightening, welding, heavy electrical equipment, or switch gears. Refer to the Rosemount 470 Product Data Sheet (Document Number 00813-0100-4191) for more information.

Temperature limits

Operating limit

- -40 to 185 °F (-40 to 85 °C)

Storage limit

- -58 to 248 °F (-50 to 120 °C)

Turn-on time

Performance within specifications in less than 5.0 seconds after power is applied to transmitter, when damping value is set to zero seconds.

Update rate

Less than 0.5 seconds

Custom alarm and saturation levels

Custom configuration of alarm and saturation levels is available by using the 148 PC Programmer.

Software detected failure mode

The values at which the transmitter drives its output in failure mode depends on device configuration. The device can be configured to meet NAMUR-compliant (NAMUR recommendation NE 43) operation. The values for standard and NAMUR-compliant operation are as follows:

Table A-1. Operation Parameters

	Standard ⁽¹⁾	NAMUR NE43- Compliant ⁽¹⁾
Linear Output:	$3.9 \leq I \leq 20.5$	$3.8 \leq I \leq 20.5$
Fail High:	$21 \leq I \leq 23$ (default)	$21 \leq I \leq 23$
Fail Low:	$I \leq 3.75$	$I \leq 3.6$

(1) Measured in milliamperes.

Certain hardware failures, such as microprocessor failures, will always drive the output to greater than 23 mA.

A.1.2 Physical specifications

Communication connections

Communication Terminal: Clips permanently fixed to the terminals.

Materials of construction

Electronics housing

- Noryl® glass reinforced

Universal (option codes U and H) heads

- Housing: Low-copper aluminum (option code U)
Stainless Steel (option code H)
- Paint: Polyurethane
- Cover O-Ring: Buna-N

Mounting

The Rosemount 148 installs in a connection head or universal head mounted directly on a sensor assembly or apart from a sensor assembly using a universal head. The Rosemount 148 can also mount to a DIN rail using an optional mounting clip.

Weight

Code	Options	Weight
148	Head Mount Transmitter	42 g (1.5 oz)
U	Universal Head	520 g (18.4 oz)
H	Universal Head (SST)	1700 g (60 oz)

Enclosure ratings

The Universal (option codes U and H) Heads are NEMA 4X, IP66, and IP68. The Universal Head with 1/2-in. NPT threads is CSA Enclosure Type 4X.

A.1.3 Performance specifications

EMC (ElectroMagnetic Compatibility) NAMUR NE21 Standard

The Rosemount 148 meets the requirements for NAMUR NE21 Rating

Susceptibility	Parameter	Influence
ESD	<ul style="list-style-type: none"> • 6 kV contact discharge • 8 kV air discharge 	None
Radiated	<ul style="list-style-type: none"> • 80 – 1000 MHz at 10 V/m AM 	None
Burst	<ul style="list-style-type: none"> • 1 kV for I.O. 	None
Surge	<ul style="list-style-type: none"> • 0.5 kV line–line • 1 kV line–ground 	None
Conducted	<ul style="list-style-type: none"> • 150 kHz to 80 MHz at 10 V 	None

CE mark

The Rosemount 148 meets all requirements listed under IEC 61326: Amendment 1, 2006

Power supply effect

Less than $\pm 0.005\%$ of span per volt

Vibration effect

The Rosemount 148 is tested to the following specifications with no effect on performance:

Frequency	Vibration
10 to 60 Hz	0.21 mm displacement
60 to 2000 Hz	3 g peak acceleration

Stability

For RTD and thermocouple inputs, the transmitter will have a stability of $\pm 0.15\%$ of reading or $0.15\text{ }^{\circ}\text{C}$ (whichever is greater) for twelve months.

Sensor connections

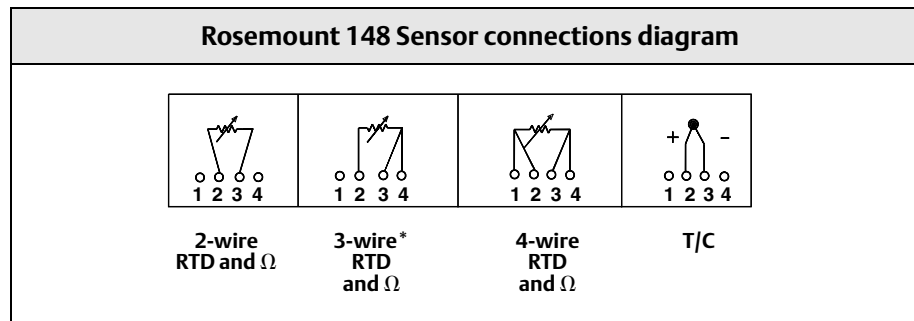

* Rosemount Inc. provides 4-wire sensors for all single element RTDs. You can use these RTDs in 3-wire configurations by leaving the unneeded leads disconnected and insulated with electrical tape.

Transmitter accuracy and ambient temperature effects

Note

The accuracy and ambient temperature effect is the greater of the fixed and percent of span values (see example below).

Table A-2. Rosemount 148 Transmitter Input Options, Accuracy, and Ambient Temperature Effects

Sensor	Transmitter Input Ranges ⁽¹⁾		Accuracy		Temperature Effects per 1.0 °C (1.8 °F) Change in Ambient Temperature ⁽²⁾	
	°C	°F	Fixed	% of Span	Fixed	% of Span
2-, 3-, 4-wire RTDs						
Pt 100 ⁽³⁾ (α = 0.00385)	-200 to 850	-328 to 1562	0.3 °C (0.54 °F)	±0.15	0.009 °C (0.016 °F)	±0.006
Pt 100 ⁽⁴⁾ (α = 0.003916)	-200 to 645	-328 to 1193	0.3 °C (0.54 °F)	±0.15	0.009 °C (0.016 °F)	±0.006
Ni 120 ⁽⁵⁾	-70 to 300	-94 to 572	0.2 °C (0.36 °F)	±0.15	0.006 °C (0.011 °F)	±0.006
Cu 10 ⁽⁶⁾	-50 to 250	-58 to 482	3 °C (5.40 °F)	±0.15	0.09 °C (0.16 °F)	±0.006
Thermocouples ⁽⁷⁾						
Type B ⁽⁸⁾⁽⁹⁾	100 to 1820	212 to 3308	2.3 °C (4.05 °F)	±0.15	0.084 °C (0.150 °F)	±0.006
Type J ⁽⁸⁾	-180 to 760	-292 to 1400	0.8 °C (1.35 °F)	±0.15	0.03 °C (0.054 °F)	±0.006
Type K ⁽⁸⁾⁽¹⁰⁾	-180 to 1372	-292 to 2502	0.8 °C (1.35 °F)	±0.15	0.03 °C (0.054 °F)	±0.006
Type N ⁽⁸⁾	-200 to 1300	-328 to 2372	1.2 °C (2.16 °F)	±0.15	0.03 °C (0.054 °F)	±0.006
Type R ⁽⁸⁾	0 to 1768	32 to 3214	1.8 °C (3.24 °F)	±0.15	0.09 °C (0.16 °F)	±0.006
Type S ⁽⁸⁾	0 to 1768	32 to 3214	1.5 °C (2.70 °F)	±0.15	0.09 °C (0.16 °F)	±0.006
2-, 3-, 4-wire Ohm Input	0 to 2000 ohms		1.1 ohm	±0.15	0.042 ohm	±0.006

(1) Input ranges are for transmitter only. Actual sensor (RTD or Thermocouple) operating ranges may be more limited.

(2) Change in ambient is with reference to the calibration temperature of the transmitter at 68 °F (20 °C) from factory.

(3) IEC 751, 1995.

(4) JIS 1604, 1981.

(5) Edison Curve No. 7.

(6) Edison Copper Winding No. 15.

(7) Total accuracy for thermocouple measurement: sum of accuracy +0.5 °C.

(8) NIST Monograph 175, IEC 584.

(9) Fixed accuracy for NIST Type B is ±5.4 °F (±3.0 °C) from 212 to 572 °F (100 to 300 °C).

(10) Fixed accuracy for NIST Type K is ±1.3 °F (±0.7 °C) from -292 to -130 °F (-130 to -90 °C).

Transmitter accuracy example

When using a Pt 100 (a = 0.00385) sensor input with a 0 to 100 °C span, use the greater of the two calculated values. In this case the accuracy would be +/-0.3 °C.

Transmitter temperature effects example

Transmitters can be installed in locations where the ambient temperature is between -40 and 85 °C (-40 and 185 °F). In order to maintain excellent accuracy performance, each transmitter is individually characterized over this ambient temperature range at the factory.

When using a Pt 100 (a = 0.00385) sensor input with a 0–100 °C span at 30 °C ambient temperature:

- Temperature Effects: 0.009 °C x (30 - 20) = 0.09 °C

Total transmitter error

Worst Case Transmitter Error: Accuracy + Temperature Effects = 0.3 °C + 0.09 °C = 0.39 °C

Total Probable Transmitter Error: $\sqrt{0.3^2 + 0.09^2} = 0.31$ °C

A.2 Dimensional drawings

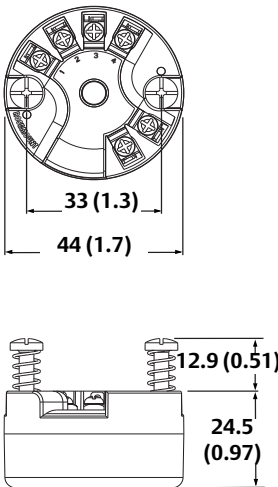
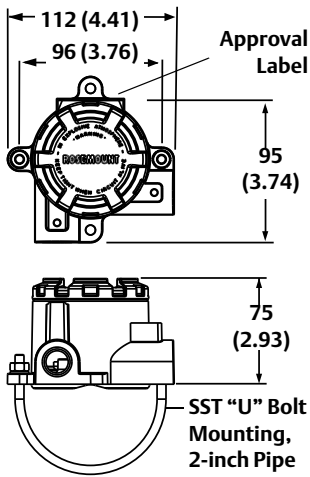
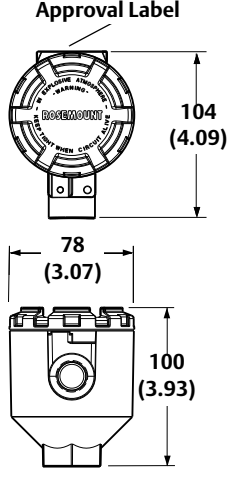
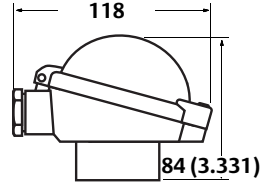
Rosemount 148 Transmitter		
(enlarged)		
		
Dimensions are in millimeters (inches).		
Enclosures		
Universal head ⁽¹⁾ (option codes H and U)	Connection head ⁽²⁾	BUZ and polypropylene heads ⁽²⁾
		
Dimensions are in millimeters (inches).		

- (1) A "U" Bolt is shipped with each universal head unless a sensor is ordered assembled to the enclosure. However, since the head can be integrally mounted to the sensor it may not need to be used.
- (2) Consult factory for ordering availability.

Examples of 148 Assemblies with Sensors and Thermowells		
Tubular Thermowell and DIN Plate Style Sensor	Barstock Thermowell and DIN Plate Style Sensor	Barstock Thermowell, Nipple-Union Extension, and 1/2-in. NPT Spring Loaded Sensor
<p>* 80 (3.2) for Class 900 flanges and larger</p>		
<p><i>N = Extension Length, U = Thermowell Immersion Length,</i> SEE SENSOR DOCUMENTATION FOR MORE ASSEMBLY OPTIONS</p>		

Dimensions are in millimeters (inches).

A.3 Ordering information

Table A-3. Rosemount 148 PC-Programmable Temperature Transmitter

★ The Standard offering represents the most common options. The starred options (★) should be selected for best delivery.
The Expanded offering is subject to additional delivery lead time.

Model	Product description			
148	PC Programmable Temperature Transmitter			
Transmitter type				
Standard				Standard
H	DIN B Head Mount			★
Transmitter output				
Standard				Standard
N	Analog Output			★
Product certifications				
Standard				Standard
I5	FM Intrinsic Safety and Class 1, Division 2			★
E5 ⁽¹⁾	FM Explosion-Proof			★
K5 ⁽¹⁾	FM Intrinsic Safety, Explosion-Proof, and Class 1, Division 2			★
I6	CSA Intrinsic Safety and Class 1, Division 2			★
K6 ⁽¹⁾	CSA Intrinsic Safety, Explosion-Proof, and Class 1, Division 2			★
I1	ATEX Intrinsic Safety			★
E1 ⁽¹⁾	ATEX Flameproof			★
N1 ⁽¹⁾	ATEX Type n			★
NC	ATEX Type n Component			★
ND ⁽¹⁾	ATEX Dust Ignition-Proof			★
I7	IECEx Intrinsic Safety			★
E7 ⁽¹⁾	IECEx Flameproof and Dust			★
N7 ⁽¹⁾	IECEx Type n			★
NG	IECEx Type n Component			★
NA	No approvals			★
Enclosure options				Material
				IP Rating
Standard				Standard
A	Connection Head		Aluminum	IP68
U	Universal Head (Junction Box)		Aluminum	IP68
B	BUZ Head		Aluminum	IP65
C	BUZ Head		Polypropylene	IP65
N	No Enclosure			★
Expanded				
G	Connection Head		SST	IP68
H	Universal Head (Junction Box)		SST	IP68
S	Sanitary Connection Head, DIN B		Polished SST	IP66
F	Sanitary Connection Head, DIN A		Polished SST	IP66/IP68
Conduit entry size				
Standard				Standard
1	M20 x 1.5 (CM20)			★
2	1/2-14 in. NPT			★
0	No Enclosure			★

Table A-3. Rosemount 148 PC-Programmable Temperature Transmitter

★ The Standard offering represents the most common options. The starred options (★) should be selected for best delivery.
The Expanded offering is subject to additional delivery lead time.

Options (include with selected model number)

Alarm level configuration		
Standard		Standard
A1	NAMUR alarm and saturation levels, high alarm	★
CN	NAMUR alarm and saturation levels, low alarm	★
Calibration certificate		
Standard		Standard
Q4	Calibration Certificate (3-point Calibration)	★
Line filter		
Standard		Standard
F6	60 Hz Line Voltage Filter	★
External ground option (available w/enclosures U, H)		
Standard		Standard
G1	External Ground Lug Assembly	★
Cover chain option (available w/enclosures U, H)		
Standard		Standard
G3	Cover Chain	★
Cable gland option		
Standard		Standard
G2	Cable Gland–Explosion Proof–7.5 mm - 11.9 mm	★
G4	Cable Gland–Explosion Proof, Thin Wire - 3.0 mm - 8.0 mm	★
Conduit electrical connector		
Standard		Standard
GE	M12, 4-pin, Male Connector (eurofast®)	★
GM	A size Mini, 4-pin, Male Connector (minifast®)	★
Assemble to options		
Standard		Standard
XA	Sensor Specified Separately and Assembled to Transmitter	★
Typical model number: 148 H N I5 U1 A1 XA		

(1) Approval Codes E1, N1, N7, ND, E5, K5, K6, and E7 require an enclosure.

Appendix B Product Certifications

B.1 Approved Manufacturing Locations

Rosemount Inc. - Chanhassen, Minnesota, USA
Rosemount Temperature GmbH - Germany
Emerson Process Management Asia Pacific - Singapore

B.2 European Directive Information

A copy of the EC Declaration of Conformity can be found at the end of the Quick Start Guide. The most recent revision of the EC Declaration of Conformity can be found at www.rosemount.com.

B.3 Ordinary Location Certification from FM Approvals

As standard, the transmitter has been examined and tested to determine that the design meets the basic electrical, mechanical, and fire protection requirements by FM Approvals, a nationally recognized test laboratory (NRTL) as accredited by the Federal Occupational Safety and Health Administration (OSHA).

B.3.1 North America

- E5** FM Explosionproof, Dust-Ignitionproof, and Nonincendive
Certificate: 3032198
Standards Used: FM Class 3600:1998, FM Class 3611:2004, FM Class 3615:1989, FM Class 3810:2005, IEC 60529: 2001, NEMA - 250: 1991
Markings: **XP** CL I, DIV 1, GP B, C, D; **DIP** CL II/III, DIV 1, GP E, F, G; **NI** CL I, DIV 2, GP A, B, C, D; T5(-50 °C ≤ Ta ≤ + 85 °C); when installed per Rosemount drawing 00148-1065; Type 4X; IP66/68.
- I5** FM Intrinsic Safety and Nonincendive
Certificate: 3032198
Standards Used: FM Class 3600:1998, FM Class 3610:1999, FM Class 3611:2004, FM Class 3810:2005, IEC 60529: 2001, NEMA - 250: 1991
Markings: **IS** CL I/II/III, DIV 1, GP A, B, C, D, E, F, G; **NI** CL1, DIV 2, GP A, B, C, D; T6(-50 °C ≤ Ta ≤ + 40 °C), T5(-50 °C ≤ Ta ≤ + 75 °C) when installed per Rosemount drawing 00148-1055; Type 4X; IP66/68.
- Special conditions for safe use (X):**
1. When no enclosure option is selected, the Model 148 Temperature Transmitter shall be installed in an enclosure meeting the requirements of ANSI/ISA S82.01 and S82.03 or other applicable ordinary location standards.
 2. No enclosure or Buz Head option cannot be selected to maintain a Type 4X rating.
 3. Enclosure option must be selected to maintain a Type 4 Rating.

- I6** CSA Intrinsic Safety, and Division 2
Certificate: 1091070
Standards Used: CAN/CSA C22.2 No. 0-M90, CSA Std. C22.2 No. 25-1966, CSA Std. C22.2 No. 30-M1986, CAN/CSA C22.2 No. 94-M91, CSA Std. C22.2 No.142-M1987, CAN/CSA C22.2 No. 157-92, CSA C22.2 No. 213-M1987, C22.2 No 60529-05.
Markings: **IS** CL I, DIV 1 GP A, B, C, D when installed per Rosemount drawing 00248-1056; Suitable for **CL I DIV 2** GP A, B, C, D when installed per Rosemount drawing 00248-1055; T6(-50 °C ≤ Ta ≤ +40 °C), T5(-50 °C ≤ Ta ≤ +60 °C); Type 4X, IP66/68 for enclosure options “A”, “G”, “H”, “U”; Seal not required (See drawing 00248-1066).
- K6** CSA Explosionproof, Intrinsic Safety, and Division 2
Certificate: 1091070
Standards Used: CAN/CSA C22.2 No. 0-M90, CSA Std. C22.2 No. 25-1966, CSA Std. C22.2 No. 30-M1986, CAN/CSA C22.2 No. 94-M91, CSA Std. C22.2 No.142-M1987, CAN/CSA C22.2 No. 157-92, CSA C22.2 No. 213-M1987, C22.2 No 60529-05.
Markings: **XP** CL I/II/III, DIV 1, GP B, C, D, E, F, G when installed per Rosemount drawing 00248-1066; **IS** CL I, DIV 1 GP A, B, C, D when installed per Rosemount drawing 00248-1056; Suitable for **CL I DIV 2** GP A, B, C, D when installed per Rosemount drawing 00248-1055; T6(-50 °C ≤ Ta ≤ +40 °C), T5(-50 °C ≤ Ta ≤ +60 °C); Type 4X, IP66/68 for enclosure options “A”, “G”, “H”, “U”; Seal not required (See drawing 00248-1066).

B.3.2 Europe

- E1** ATEX Flameproof
Certificate: FM12ATEX0065X
Standards Used: EN 60079-0: 2012, EN 60079-1: 2007, EN 60529:1991 +A1:2000
Markings: Ⓜ II 2 G Ex d IIC T6...T1 Gb, T6(-50 °C ≤ Ta ≤ +40 °C), T5...T1(-50 °C ≤ Ta ≤ +60 °C);
See [Table B-1](#) at the end of the Product Certifications section for Process Temperatures
Special conditions for safe use (X):
1. See certificate for ambient temperature range.
 2. The non-metallic label may store an electrostatic charge and become a source of ignition in Group III environments.
 3. Guard the LCD cover against impact energies greater than 4 joules.
 4. Consult the manufacturer if dimensional information on the flameproof joints is necessary.
- I1** ATEX Intrinsic Safety
Certificate: Baseefa08ATEX0030X
Standards Used: EN 60079-0: 2012, EN 60079-11: 2012
Markings: Ⓜ II 1 G Ex ia IIC T5/T6 Ga, T5(-60 °C ≤ Ta ≤ +80 °C), T6(-60 °C ≤ Ta ≤ +60 °C);
See [Table B-2](#) at the end of the Product Certifications section for Entity Parameters.
Special condition for safe use (X):
1. The apparatus must be installed in an enclosure which affords it a degree of protection of at least IP20. Non-metallic enclosures must have a surface resistance of less than 1 GΩ; light alloy or zirconium enclosures must be protected from impact and friction when installed.
- N1** ATEX Type n - with enclosure
Certificate: BAS00ATEX3145
Standards Used: EN 60079-0:2012, EN 60079-15:2010
Markings: Ⓜ II 3 G Ex nA IIC T5 Gc (-40 °C ≤ Ta ≤ +70 °C);

NC ATEX Type n - without enclosure
Certificate: Baseefa13ATEX0092X
Standards Used: EN 60079-0:2012, EN 60079-15:2010
Markings:  II 3 G Ex nA IIC T5/T6 Gc, T5(-60 °C ≤ Ta ≤ +80 °C), T6(-60 °C ≤ Ta ≤ +60 °C);

Special condition for safe use (X):

1. The Model 148 Temperature Transmitter must be installed in a suitably certified enclosure such that it is afforded a degree of protection of at least IP54 in accordance with IEC 60529 and EN 60079-15.

ND ATEX Dust
Certificate: FM12ATEX0065X
Standards Used: EN 60079-0: 2012, EN 60079-31: 2009, EN 60529:1991 +A1:2000
Markings:  II 2 D Ex tb IIIC T130 °C Db, (-40 °C ≤ Ta ≤ +70 °C); IP66
See [Table B-1](#) at the end of the Product Certifications section for Process Temperatures

Special conditions for safe use (X):

1. See certificate for ambient temperature range.
2. The non-metallic label may store an electrostatic charge and become a source of ignition in Group III environments.
3. Guard the LCD cover against impact energies greater than 4 joules.
4. Consult the manufacturer if dimensional information on the flameproof joints is necessary.

B.3.3 International

E7 IECEx Flameproof and Dust
Certificate: IECEx FMG 12.0022X
Standards Used: IEC 60079-0:2011, IEC 60079-1:2007-04, IEC 60079-31:2008
Markings: Ex d IIC T6...T1 Gb, T6(-50 °C ≤ Ta ≤ +40 °C), T5...T1(-50 °C ≤ Ta ≤ +60 °C);
Ex tb IIIC T130 °C Db, (-40 °C ≤ Ta ≤ +70 °C); IP66;
See [Table B-1](#) at the end of the Product Certifications section for Process Temperatures

Special conditions for safe use (X):

1. See certificate for ambient temperature range.
2. The non-metallic label may store an electrostatic charge and become a source of ignition in Group III environments.
3. Guard the LCD cover against impact energies greater than 4 joules.
4. Consult the manufacturer if dimensional information on the flameproof joints is necessary.

I7 IECEx Intrinsic Safety
Certificate: IECEx BAS 08.0011X
Standards Used: IEC 60079-0:2011, IEC 60079-11:2011
Markings: Ex ia IIC T5/T6 Ga, T5(-60 °C ≤ Ta ≤ +80 °C), T6(-60 °C ≤ Ta ≤ +60 °C);
See [Table B-2](#) at the end of the Product Certifications section for Entity Parameters

Special condition for safe use (X):

1. The apparatus must be installed in an enclosure which affords it a degree of protection of at least IP20. Non-metallic enclosures must have a surface resistance of less than 1 GΩ; light alloy or zirconium enclosures must be protected from impact and friction when installed.

- N7** IECEx Type n - with enclosure
Certificate: IECEx BAS 07.0055
Standards Used: IEC 60079-0:2011, IEC 60079-15:2010
Markings: Ex nA IIC T5 Gc; T5(-40 °C ≤ Ta ≤ +70 °C).
- NG** IECEx Type n - without enclosure
Certificate: IECEx BAS 13.0052X
Standards Used: IEC 60079-0:2011, IEC 60079-15:2010
Markings: Ex nA IIC T5/T6 Gc; T5(-60 °C ≤ Ta ≤ +80 °C), T6(-60 °C ≤ Ta ≤ +60 °C)
- Special condition for safe use (X):**
- The Model 248 Temperature Transmitter must be installed in a suitably certified enclosure such that it is afforded a degree of protection of at least IP54 in accordance with IEC 60529 and IEC 60079-15.

B.3.4 Combinations

- K5** Combination of E5 and I5

B.4 Tables

Table B-1. Process temperatures

Temperature class	Ambient temperature	Process temperature w/o LCD cover (°C)			
		No ext.	3"	6"	9"
T6	-50 °C to +40 °C	55	55	60	65
T5	-50 °C to +60 °C	70	70	70	75
T4	-50 °C to +60 °C	100	110	120	130
T3	-50 °C to +60 °C	170	190	200	200
T2	-50 °C to +60 °C	280	300	300	300
T1	-50 °C to +60 °C	440	450	450	450

Table B-2. Entity parameters

	HART loop terminals + and -	Sensor terminals 1 to 4
Voltage U_i	30 V	45 V
Current I_i	130 mA	26 mA
Power P_i	1 W	290 mW
Capacitance C_i	3.6 nF	2.1 nF
Inductance L_i	0 mH	0 μH

Figure B-1. Installation drawing: 148 FM Intrinsic Safety, Drawing no. 00148-1055, Rev AA (1 of 2)

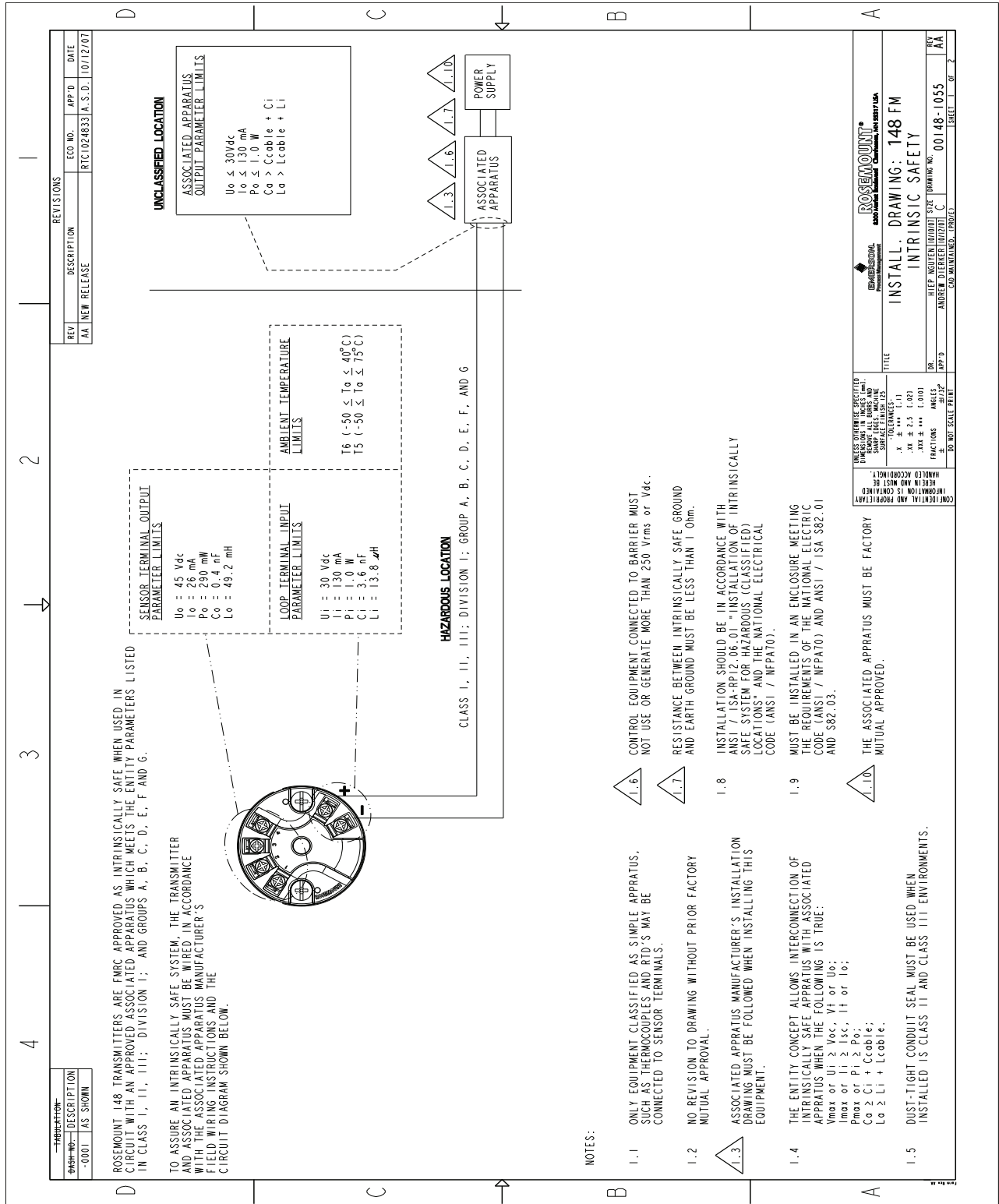

Figure B-2. Installation drawing: 148 FM Intrinsic Safety, Drawing no. 00148-1055, Rev AA (2 of 2)

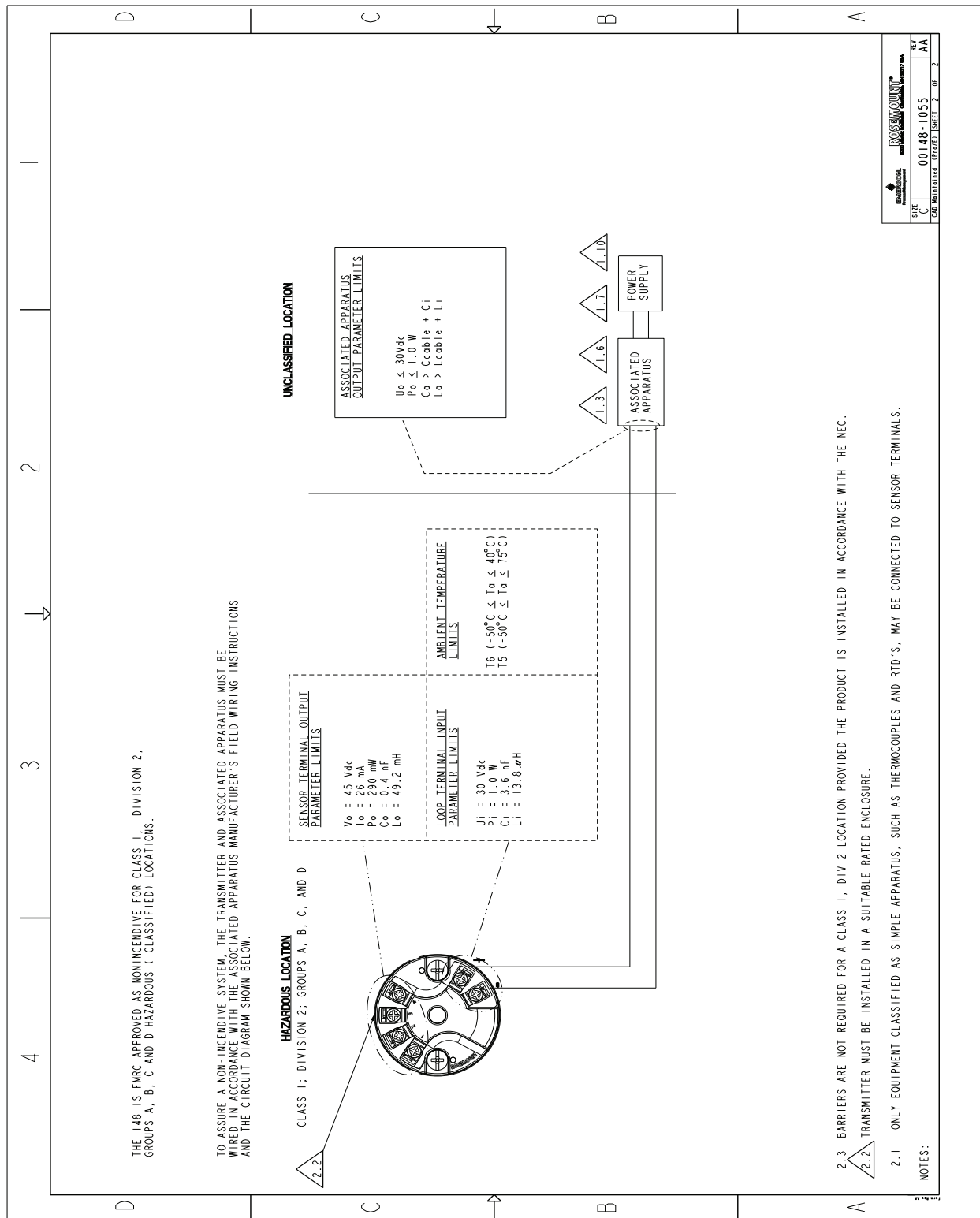

Figure B-4. CSA Explosion-Proof and Non-Incendive installation drawing, Drawing no. 00148-1056, Rev AA

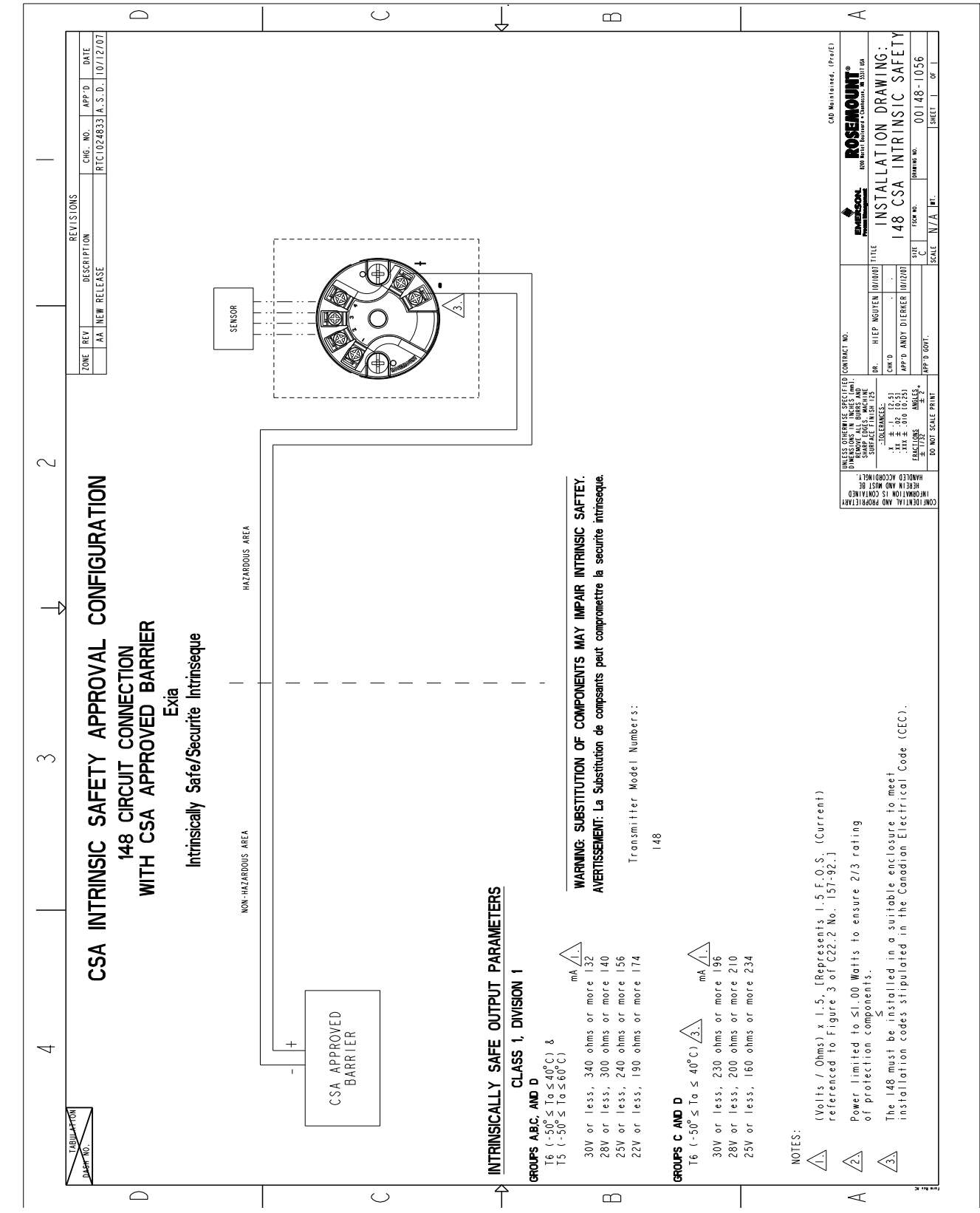

Figure B-5. IECEx Intrinsic Safety installation drawing, Drawing no. 00148-1057, Rev AA

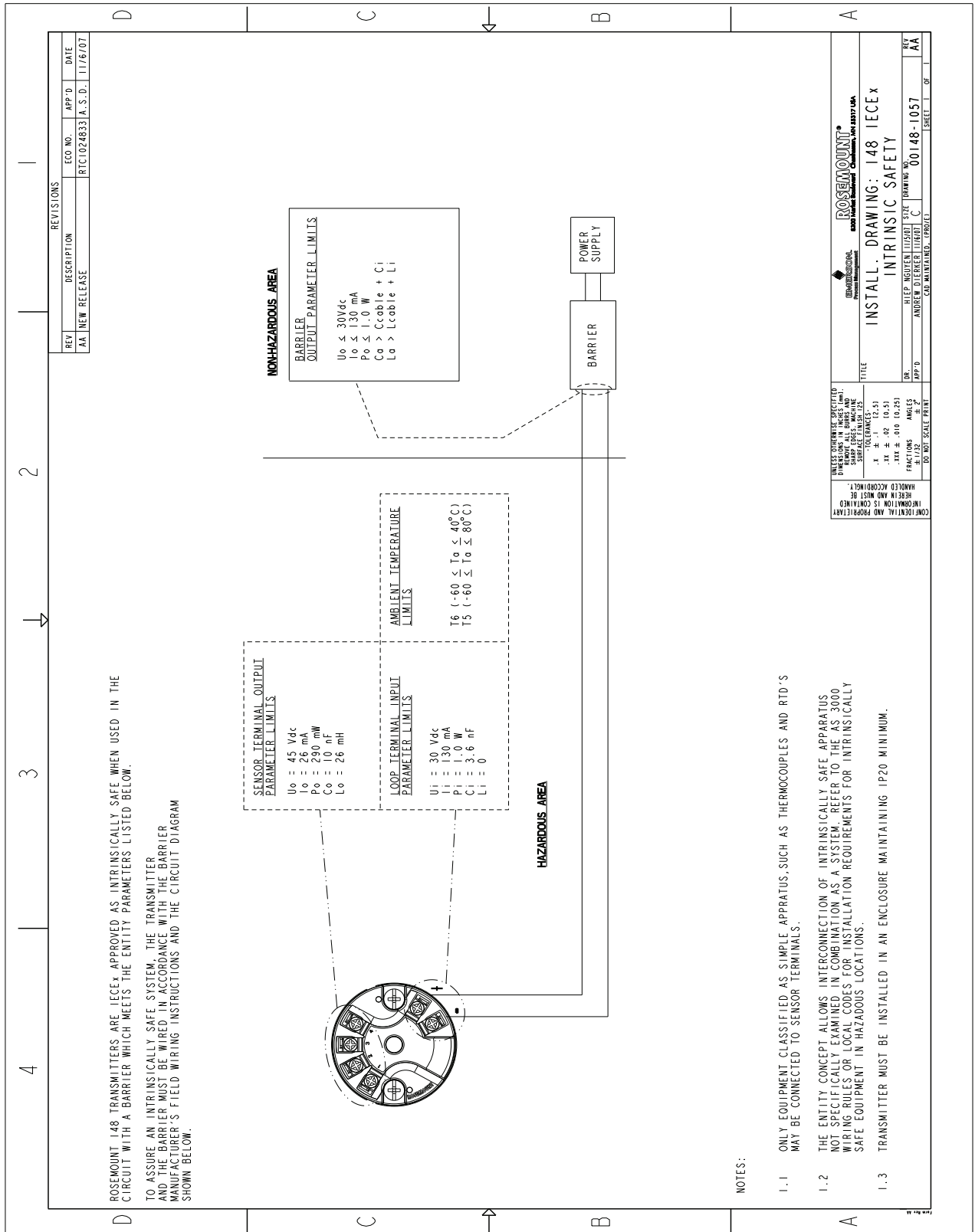
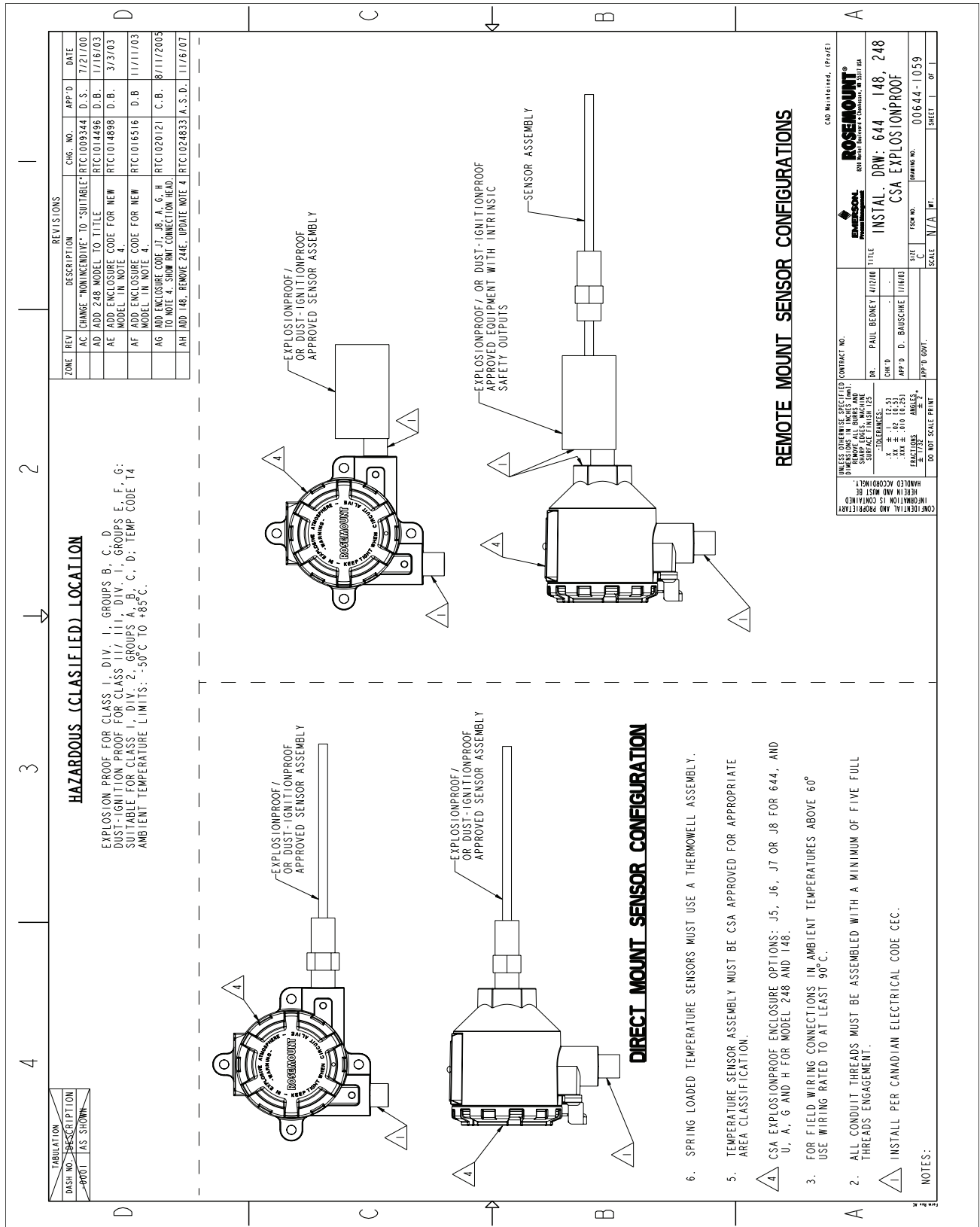

Figure B-6. CSA Explosion-Proof installation drawing, Drawing no. 00644-1059, Rev AH



Standard Terms and Conditions of Sale can be found at www.rosemount.com/terms_of_sale
The Emerson logo is a trademark and service mark of Emerson Electric Co.
Rosemount, the Rosemount logotype, and SMART FAMILY are registered trademarks of Rosemount Inc.
Coplanar is a trademark of Rosemount Inc.
Halocarbon is a trademark of the Halocarbon Products Corporation.
Fluorinert is a registered trademark of Minnesota Mining and Manufacturing Company Corporation
Syltherm 800 and D.C. 200 are registered trademarks of Dow Corning Corporation.
Neobee M-20 is a registered trademark of PVO International, Inc.
HART is a registered trademark of the HART Communication Foundation.
Foundation fieldbus is a registered trademark of the Fieldbus Foundation.
All other marks are the property of their respective owners.

© April 2014 Rosemount, Inc. All rights reserved.

Emerson Process Management
Rosemount Measurement
8200 Market Boulevard
Chanhassen MN 55317 USA
Tel (USA) 1 800 999 9307
Tel (International) +1 952 906 8888
Fax +1 952 906 8889

**Emerson Process Management
GmbH & Co.**
Argelsrieder Feld 3
82234 Wessling
Germany
Tel 49 (8153) 9390
Fax 49 (8153) 939172

**Emerson Process Management Asia
Pacific Private Limited**
1 Pandan Crescent
Singapore 128461
T (65) 6777 8211
F (65) 6777 0947
Enquiries@AP.EmersonProcess.com

**Beijing Rosemount Far East
Instrument Co., Limited**
No. 6 North Street,
Hepingli, Dong Cheng District
Beijing 100013, China
T (86) (10) 6428 2233
F (86) (10) 6422 8586

**Emerson Process Management
Latin America**
1300 Concord Terrace, Suite 400
Sunrise Florida 33323 USA
Tel + 1 954 846 5030

ROSEMOUNT®

