

Rosemount 148 Temperature Transmitter



- Basic temperature transmitter offers a cost-effective solution for temperature monitoring points.
- Standard transmitter design provides flexible and reliable performance in process environments.
- Experience lower overall installation costs when compared to wiring sensor directly, reducing the need for expensive extension wires and multiplexers.
- PC-based HART® configuration interface delivers a programmer, cables, and the software needed for transmitter configuration.
- Explore the benefits of a complete point solution from Rosemount Temperature.

Rosemount 148 Temperature Transmitter

Basic temperature transmitter offers a cost-effective solution for temperature monitoring points

- DIN B style head mount transmitter
- Variety of DIN B enclosure options
- 4-20 mA analog protocol
- Single sensor capability with universal sensor inputs (RTD, T/C, ohms)
- PC-based configuration

Standard transmitter design provides flexible and reliable performance in process environments

- Offers improved measurement accuracy and reliability over direct-wiring a sensor to the digital control system for a lower overall installation cost
- One-year stability rating reduces maintenance costs
- PC-based configuration interface delivers a programmer, cables, and the software needed for transmitter configuration
- Compensation for ambient temperature enhances transmitter performance

Explore the benefits of a complete point solution from Rosemount Temperature Measurement

- An “Assemble To Sensor” option enables Emerson to provide a complete point temperature solution, delivering an installation-ready transmitter and sensor assembly.
- Emerson offers a selection of RTDs, thermocouples, and thermowells that bring superior durability and Rosemount reliability to temperature sensing, complementing the Rosemount Transmitter portfolio.

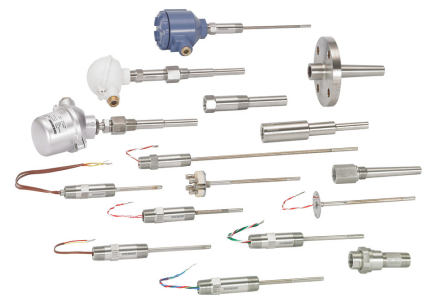

Contents

Ordering Information	4	Dimensional Drawings	10
Rosemount 148 Configuration Interface Specifications	6	Product Certifications	11
Transmitter Specifications	7		

Experience global consistency and local support from numerous worldwide Rosemount Temperature manufacturing sites



- World-class manufacturing provides globally consistent product from every factory and the capacity to fulfill the needs of any project, large or small.
- Experienced Instrumentation Consultants help select the right product for any temperature application and advise on best installation practices.
- An extensive global network of Emerson service and support personnel can be on-site when and where needed.

-
- Looking to measure more temperature points in a cost effective way? Consider a wireless temperature solution. The Rosemount 148 Wireless Temperature Transmitter is solid performing, yet economical.
 - For temperature installations that require reliable measurement and can benefit from HART functionality, the Rosemount 148 Temperature Transmitter is a cost-effective solution.
-

Ordering Information



The Rosemount 148 Temperature Transmitter has a standard transmitter design that provides reliable performance in process environments.

Transmitter features include:

- 4-20 mA Analog Output
- Variety of DIN B enclosure options
- 3-Point Calibration Certificate (Option Code Q4)
- Assemble to Sensor option (Option Code XA)

Specification and selection of product materials, options, or components must be made by the purchaser of the equipment. See [page 8](#) for more information on Material Selection.

Table 1. Rosemount 148 PC-Programmable Temperature Transmitter Ordering Information

★ The Standard offering represents the most common options. The starred options (★) should be selected for best delivery. The Expanded offering is subject to additional delivery lead time.

Model	Product description		
148	PC Programmable Temperature Transmitter		
Transmitter type			
H	DIN B Head Mount		★
Transmitter output			
N	Analog Output		★
Product certifications			Enclosure option codes permitted
I5	FM Intrinsic Safety and Class 1, Division 2		A, B, U, G, H, N
E5 ⁽¹⁾	FM Explosion-Proof		A, U, G, H
K5 ⁽¹⁾	FM Intrinsic Safety, Explosion-Proof, and Class 1, Division 2		A, U, G, H
I6	CSA Intrinsic Safety and Class 1, Division 2		A, B, U, G, H, N
K6 ⁽¹⁾	CSA Intrinsic Safety, Explosion-Proof, and Class 1, Division 2		A, U, G, H
I1	ATEX Intrinsic Safety		All enclosures
E1 ⁽¹⁾	ATEX Flameproof		A, U, G, H
N1 ⁽¹⁾	ATEX Type n with enclosure		A, U, G, H
NC	ATEX Type n Component without enclosure		N
ND ⁽¹⁾	ATEX Dust		A, U, G, H
I7	IECEX Intrinsic Safety		All enclosures
E7 ⁽¹⁾	IECEX Flameproof and Dust		A, U, G, H
N7 ⁽¹⁾	IECEX Type n with enclosure		A, U, G, H
NG	IECEX Type n without enclosure		N
KM	Technical Regulations Customs Union (EAC) Flameproof, Intrinsic Safety		A, U, G, H
IM	Technical Regulations Customs Union (EAC) Intrinsic Safety		All enclosures
EM	Technical Regulations Customs Union (EAC) Flameproof		A, U, G, H
NA	No approvals		All enclosures

Table 1. Rosemount 148 PC-Programmable Temperature Transmitter Ordering Information

★ The Standard offering represents the most common options. The starred options (★) should be selected for best delivery.

The Expanded offering is subject to additional delivery lead time.

Enclosure options		Material	IP rating	
A	Connection Head	Aluminum	IP68	★
U	Universal Head (Junction Box)	Aluminum	IP68	★
B	BUZ Head	Aluminum	IP65	★
C	BUZ Head	Polypropylene	IP65	★
N	No Enclosure	N/A	N/A	★
G	Connection Head	SST	IP68	
H	Universal Head (Junction Box)	SST	IP68	
S	Sanitary Connection Head, DIN B	Polished SST	IP66	
F	Sanitary Connection Head, DIN A	Polished SST	IP66/IP68	
Conduit entry size				
1	M20 × 1.5 (CM20)			★
2	1/2-14 in. NPT			★
0	No Enclosure			★

Options (include with selected model number)

Alarm level configuration		
A1	NAMUR alarm and saturation levels, high alarm	★
CN	NAMUR alarm and saturation levels, low alarm	★
Calibration certificate		
Q4	Calibration Certificate (3-point Calibration)	★
Line filter		
F6	60 Hz Line Voltage Filter	★
External ground option (available w/enclosures U, H)		
G1	External Ground Lug Assembly	★
Cover chain option (available w/enclosures U, H)		
G3	Cover Chain	★
Cable gland option		
G2	Cable Gland–Explosion Proof–7.5 mm - 11.9 mm	★
G4	Cable Gland–Explosion Proof, Thin Wire - 3.0 mm - 8.0 mm	★
Conduit electrical connector		
GE	M12, 4-pin, Male Connector (eurofast®)	★
GM	A size Mini, 4-pin, Male Connector (minifast®)	★
Assemble to options		
XA	Sensor Specified Separately and Assembled to Transmitter	★
Typical model number: 148 H N I5 U1 A1 XA		

(1) Approval Codes E1, N1, N7, ND, E5, K5, K6, and E7 require an enclosure.

Rosemount 148 Configuration Interface Specifications

Configuration software⁽¹⁾

The Rosemount 148 PC-based configuration software for the Rosemount 148 allows comprehensive configuration of the transmitters. Used in conjunction with various Rosemount or user-supplied hardware modems, the software provides the tools necessary to configure the 148 Transmitters including the following parameters:

- Process Variable
- Sensor Type
- Number of Wires
- Engineering Units
- Transmitter Tag Information
- Damping
- Alarming Parameters

Configuration hardware

The 148 Configuration Interface has 3 hardware options as follows:

Software only

- (Part #: 00148-1601-0002)
- Customer must provide appropriate communications hardware (modem, power supply, etc.).

Serial HART modem and software

- (Part #: 00148-1601-0004)
- Serial HART modem
- Customer must provide separate loop power supply and resistor.
- Requires PC serial port
- Suitable for use with powered loops

USB HART modem and software

- (Part #: 00148-1601-0003)
- USB (Universal Serial Bus) HART modem
- Customer must provide separate loop power supply and resistor.
- Requires PC with USB port
- Suitable for use with powered loops

Figure 1. Rosemount 148 Transmitter Accessories

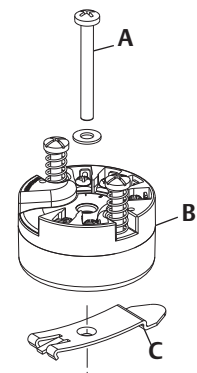

- A. Mounting Hardware
- B. Transmitter
- C. Rail Clip

Table 2. Rosemount 148 Transmitter Accessories

External Ground Screw Assembly Kit	00644-4431-0001
Kit, Hardware for Mounting a 148 to a DIN Rail (see left picture-top hat rail, symmetric)	00248-1601-0001
Snap Rings Kit (used for assembly to DIN Plate Style sensor)	00644-4432-0001

(1) The Rosemount configuration software is compatible with Microsoft® Windows™ XP, Windows 7 32-bit and Windows 7 64-bit. It is not compatible with Windows NT and Windows 2000.

Transmitter Specifications

Functional specifications

Inputs

User-selectable; sensor terminals rates to 42.4 Vdc. See “Transmitter accuracy and ambient temperature effects” on page 8 for sensor options.

Output

2-wire 4–20 mA, linear with temperature or input

Isolation

Input/Output isolation tested to 500 Vac rms (707 Vdc) at 50/60 Hz.

Supply voltage DC

Standard: 12 to 35 V

Intrinsic Safety: 12 to 28 V

Minimum voltage across terminals

12 Vdc

Humidity limits

0 - 95% relative humidity, non-condensing

NAMUR recommendations

The 148 meets the following NAMUR recommendations:

- NE 21 - Electromagnetic compatibility (EMC) for Process and Laboratory Apparatus
- NE 43 - Standard of the signal level breakdown information of digital transmitters

Transient protection

The optional Rosemount 470 Transient Protector prevents damage from transients induced by lightning, welding, heavy electrical equipment, or switch gears. Refer to the 470 Product Data Sheet (document number 00813-0100-4191) for more information.

Temperature limits

Operating Limit

-40 to 185 °F (-40 to 85 °C)

Storage Limit

-58 to 248 °F (-50 to 120 °C)

Turn-on time

Performance within specifications is less than 5.0 seconds after power is applied to the transmitter, when damping value is set to zero seconds.

Update rate

Less than 0.5 seconds

Damping

32 seconds maximum, 5 seconds default.

Recommended minimum measuring span

18 °F (10 °C)

Software detected failure mode

The values at which the transmitter drives its output in failure mode depends on device configuration. The device can be configured to meet NAMUR-compliant (NAMUR recommendation NE 43) operation. The values for standard and NAMUR-compliant operation are as follows:

Table 3. Operation Parameters

	Standard ⁽¹⁾	NAMUR NE43-Compliant ⁽¹⁾
Linear Output:	$3.9 \leq I \leq 20.5$	$3.8 \leq I \leq 20.5$
Fail High:	$21 \leq I \leq 23$ (default)	$21 \leq I \leq 23$ (default)
Fail Low:	$I \leq 3.75$	$I \leq 3.6$

(1) Measured in milliamperes.

Certain hardware failures, such as microprocessor failures, will always drive the output to greater than 23 mA.

Performance specifications

Material selection

Emerson provides a variety of Rosemount product with various product options and configurations including materials of construction that can be expected to perform well in a wide range of applications. The Rosemount product information presented is intended as a guide for the purchaser to make an appropriate selection for the application. It is the purchaser's sole responsibility to make a careful analysis of all process parameters (such as all chemical components, temperature, pressure, flow rate, abrasives, contaminants, etc.), when specifying product, materials, options and components for the particular application. Emerson Process Management is not in a position to evaluate or guarantee the compatibility of the process fluid or other process parameters with the product, options, configuration or materials of construction selected.

EMC (Electromagnetic Compatibility) NAMUR NE21 standard

The 148 meets the requirements for NAMUR NE21 Rating.

Susceptibility	Parameter	Influence
ESD	6 kV contact discharge 8 kV air discharge	None
Radiated	80 – 1000 MHz at 10 V/m AM	None
Burst	1 kV for I.O.	None
Surge	0.5 kV line–line 1 kV line–ground (I.O. tool)	None
Conducted	150 kHz to 80 MHz at 10 V	None

CE mark

The 148 meets all of the requirements listed under IEC 61326: Amendment 1, 2006.

Power supply effect

Less than ±0.0055 of span per volt

Vibration effect

The 148 is tested to the following specifications with no effect on performance:

Frequency	Vibration
10 to 60 Hz	0.21 mm displacement
60 to 2000 Hz	3 g peak acceleration

Stability

For RTD and thermocouple inputs, the transmitter will have a stability of ±0.15% of reading or 0.15 °C (whichever is greater) for twelve months.

Sensor connections

Figure 2. 148 Sensor Connections Diagram

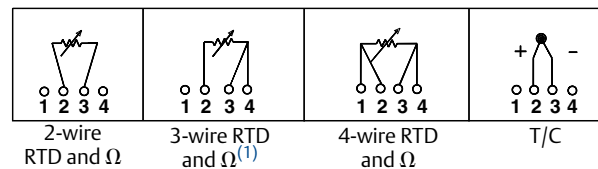

(1) Rosemount Inc. provides 4-wire sensors for all single element RTDs. You can use these RTDs in 3-wire configurations by leaving the unneeded leads disconnected and insulated with electrical tape.

Transmitter accuracy and ambient temperature effects

Note

The accuracy and ambient temperature effect is the greater of the fixed and percent of span values (see example below).

Table 4. 148 Transmitter Input Options, Accuracy, and Ambient Temperature Effects

Sensor	Transmitter input ranges ⁽¹⁾		Accuracy		Temperature effects per 1.0 °C (1.8 °F) change in ambient temperature ⁽²⁾⁽³⁾	
	°C	°F	Fixed	% of span	Fixed	% of span
Pt 100 ⁽⁴⁾ (a = 0.00385)	–200 to 850	–328 to 1562	0.3 °C (0.54 °F)	±0.15	0.009 °C (0.016 °F)	±0.006
Pt 100 ⁽⁵⁾ (a = 0.003916)	–200 to 645	–328 to 1193	0.3 °C (0.54 °F)	±0.15	0.009 °C (0.016 °F)	±0.006
Ni 120 ⁽⁶⁾	–70 to 300	–94 to 572	0.2 °C (0.36 °F)	±0.15	0.006 °C (0.011 °F)	±0.006
Cu 10 ⁽⁷⁾	–50 to 250	–58 to 482	3 °C (5.40 °F)	±0.15	0.09 °C (0.16 °F)	±0.006

Table 4. 148 Transmitter Input Options, Accuracy, and Ambient Temperature Effects

Sensor	Transmitter input ranges ⁽¹⁾		Accuracy		Temperature effects per 1.0 °C (1.8 °F) change in ambient temperature ⁽²⁾⁽³⁾	
Thermocouples⁽⁸⁾						
Type B ⁽⁹⁾⁽¹⁰⁾	100 to 1820	212 to 3308	2.3 °C (4.05 °F)	±0.15	0.084 °C (0.150 °F)	±0.006
Type J ⁽⁹⁾	-180 to 760	-292 to 1400	0.8 °C (1.35 °F)	±0.15	0.03 °C (0.054 °F)	±0.006
Type K ⁽⁹⁾⁽¹¹⁾	-180 to 1372	-292 to 2502	0.8 °C (1.35 °F)	±0.15	0.03 °C (0.054 °F)	±0.006
Type N ⁽⁹⁾	-200 to 1300	-328 to 2372	1.2 °C (2.16 °F)	±0.15	0.03 °C (0.054 °F)	±0.006
Type R ⁽⁹⁾	0 to 1768	32 to 3214	1.8 °C (3.24 °F)	±0.15	0.09 °C (0.16 °F)	±0.006
Type S ⁽⁹⁾	0 to 1768	32 to 3214	1.5 °C (2.70 °F)	±0.15	0.09 °C (0.16 °F)	±0.006
2-, 3-, 4-wire Ohm Input	0 to 2000 ohms		1.1 ohm	±0.15	0.042 ohm	±0.009

(1) Input ranges are for transmitter only. Actual sensor (RTD or Thermocouple) operating ranges may be more limited.

(2) Change in ambient is with reference to the calibration temperature of the transmitter at 68 °F (20 °C) from factory.

(3) Ambient temperature effect specification valid over minimum temperature span of 28 °C (50 °F)

(4) IEC 751, 1995.

(5) JIS 1604, 1981.

(6) Edison Curve No. 7.

(7) Edison Copper Winding No. 15.

(8) Total accuracy for thermocouple measurement: sum of accuracy +0.5 °C.

(9) NIST Monograph 175, IEC 584.

(10) Fixed accuracy for NIST Type B is ±5.4 °F (±3.0 °C) from 212 to 572 °F (100 to 300 °C).

(11) Fixed accuracy for NIST Type K is ±1.3 °F (±0.7 °C) from -292 to -130 °F (-130 to -90 °C).

Transmitter accuracy example

When using a Pt 100 ($a = 0.00385$) sensor input with a 0 to 100 °C span, use the greater of the two calculated values. In this case, the accuracy would be +/-0.3 °C.

Transmitter temperature effects example

Transmitters can be installed in locations where the ambient temperature is between -40 and 85 °C (-40 and 185 °F). In order to maintain excellent accuracy performance, each transmitter is individually characterized over this ambient temperature range at the factory.

When using a Pt 100 ($a = 0.00385$) sensor input with a 0–100 °C span at 30 °C ambient temperature:

- Temperature Effects: $0.009\text{ °C} \times (30 - 20) = 0.09\text{ °C}$

Total transmitter error

Worst Case Transmitter Error: Accuracy + Temperature Effects = $0.3\text{ °C} + 0.09\text{ °C} = 0.39\text{ °C}$

Total Probable Transmitter Error: $\sqrt{0.3^2 + 0.09^2} = 0.31\text{ °C}$

Dimensional Drawings

Figure 3. Rosemount 148 Temperature Transmitter

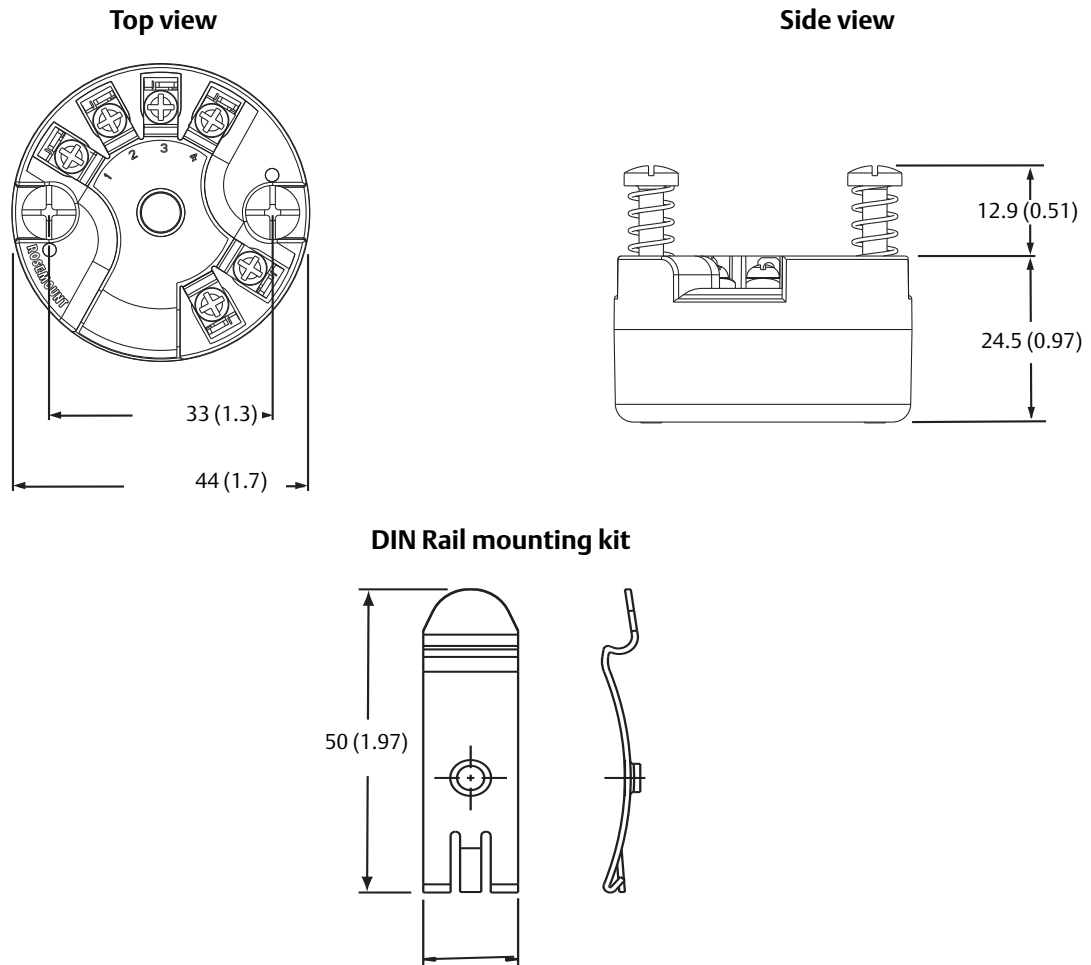

Dimensions are in millimeters (inches).

Product Certifications

Approved Manufacturing Locations

Rosemount Inc. - Chanhassen, Minnesota, USA

Rosemount Temperature GmbH - Germany

Emerson Process Management Asia Pacific - Singapore

European Directive Information

A copy of the EC Declaration of Conformity can be found at the end of the Quick Start Guide. The most recent revision of the EC Declaration of Conformity can be found at www.rosemount.com.

Ordinary Location Certification from FM Approvals

As standard, the transmitter has been examined and tested to determine that the design meets the basic electrical, mechanical, and fire protection requirements by FM Approvals, a nationally recognized test laboratory (NRTL) as accredited by the Federal Occupational Safety and Health Administration (OSHA).

North America

- E5** FM Explosionproof, Dust-Ignitionproof, and Nonincendive Certificate: 3032198
Standards: FM Class 3600:1998, FM Class 3611:2004, FM Class 3615:1989, FM Class 3810:2005, IEC 60529: 2001, NEMA - 250: 1991
Markings: XP CL I, DIV 1, GP B, C, D; DIP CL II/III, DIV 1, GP E, F, G; NI CL I, DIV 2, GP A, B, C, D; T5(-50 °C ≤ T_a ≤ +85 °C); when installed per Rosemount drawing 00148-1065; Type 4X; IP66/68
- I5** FM Intrinsic Safety and Nonincendive Certificate: 3032198
Standards: FM Class 3600:1998, FM Class 3610:1999, FM Class 3611:2004, FM Class 3810:2005, IEC 60529: 2001, NEMA - 250: 1991
Markings: IS CL I/II/III, DIV 1, GP A, B, C, D, E, F, G; NI CL 1, DIV 2, GP A, B, C, D; T6(-50 °C ≤ T_a ≤ +40 °C), T5(-50 °C ≤ T_a ≤ +75 °C) when installed per Rosemount drawing 00148-1055; Type 4X; IP66/68

Special Conditions for Safe Use (X):

- When no enclosure option is selected, the Model 148 Temperature Transmitter shall be installed in an enclosure meeting the requirements of ANSI/ISA S82.01 and S82.03 or other applicable ordinary location standards.
 - No enclosure or Buz Head option cannot be selected to maintain a Type 4X rating.
 - Enclosure option must be selected to maintain a Type 4 Rating.
- I6** CSA Intrinsic Safety and Division 2 Certificate: 1091070
Standards: CAN/CSA C22.2 No. 0-M90, CSA Std. C22.2 No. 25-1966, CAN/CSA C22.2 No. 94-M91, CAN/CSA C22.2 No. 157-92, CSA C22.2 No. 213-M1987, C22.2 No 60529-05
Markings: IS CL I, DIV 1 GP A, B, C, D when installed per Rosemount drawing 00248-1056; Suitable for CL I DIV 2 GP A, B, C, D when installed per Rosemount drawing 00248-1055; T6(-50 °C ≤ T_a ≤ +40 °C), T5(-50 °C ≤ T_a ≤ +60 °C); Type 4X, IP66/68 for enclosure options "A", "G", "H", "U"; Seal not required (See drawing 00248-1066)
- K6** CSA Explosionproof, Intrinsic Safety, and Division 2 Certificate: 1091070
Standards: CAN/CSA C22.2 No. 0-M90, CSA Std. C22.2 No. 25-1966, CSA Std. C22.2 No. 30-M1986, CAN/CSA C22.2 No. 94-M91, CSA Std. C22.2 No.142-M1987, CAN/CSA C22.2 No. 157-92, CSA C22.2 No. 213-M1987, C22.2 No 60529-05
Markings: XP CL I/II/III, DIV 1, GP B, C, D, E, F, G when installed per Rosemount drawing 00248-1066; IS CL I, DIV 1 GP A, B, C, D when installed per Rosemount drawing 00248-1056; Suitable for CL I DIV 2 GP A, B, C, D when installed per Rosemount drawing 00248-1055; T6(-50 °C ≤ T_a ≤ +40 °C), T5(-50 °C ≤ T_a ≤ +60 °C); Type 4X, IP66/68 for enclosure options "A", "G", "H", "U"; Seal not required (See drawing 00248-1066)

Europe

- E1** ATEX Flameproof
 Certificate: FM12ATEX0065X
 Standards: EN 60079-0: 2012, EN 60079-1: 2007, EN 60529:1991 +A1:2000
 Markings: Ⓔ II 2 G Ex d IIC T6...T1 Gb,
 T6(-50 °C ≤ T_a ≤ +40 °C),
 T5...T1(-50 °C ≤ T_a ≤ +60 °C);
 See [Table 5](#) at the end of the Product Certifications section for Process Temperatures

Special Conditions for Safe Use (X):

1. See certificate for ambient temperature range.
2. The non-metallic label may store an electrostatic charge and become a source of ignition in Group III environments.
3. Guard the LCD display cover against impact energies greater than 4 joules.
4. Consult the manufacturer if dimensional information on the flameproof joints is necessary.

- I1** ATEX Intrinsic Safety
 Certificate: Baseefa08ATEX0030X
 Standards: EN 60079-0: 2012, EN 60079-11: 2012
 Markings: Ⓔ II 1 G Ex ia IIC T5/T6 Ga,
 T5(-60 °C ≤ T_a ≤ + 80 °C),
 T6(-60 °C ≤ T_a ≤ + 60 °C);
 See [Table 6](#) at the end of the Product Certifications section for Entity Parameters

Special Condition for Safe Use (X):

1. The apparatus must be installed in an enclosure which affords it a degree of protection of at least IP20. Non-metallic enclosures must have a surface resistance of less than 1GΩ; light allow or zirconium enclosures must be protected from impact and friction when installed.

- N1** ATEX Type n - with enclosure
 Certificate: BAS00ATEX3145
 Standards: EN 60079-0:2012, EN 60079-15:2010
 Markings: Ⓔ II 3 G Ex nA IIC T5 Gc (-40 °C ≤ T_a ≤ + 70 °C);

- NC** ATEX Type n - without enclosure
 Certificate: Baseefa13ATEX0092X
 Standards: EN 60079-0:2012, EN 60079-15:2010
 Markings: Ⓔ II 3 G Ex nA IIC T5/T6 Gc,
 T5(-60 °C ≤ T_a ≤ + 80 °C),
 T6(-60 °C ≤ T_a ≤ + 60 °C);

Special Condition for Safe Use (X):

1. The Model 148 Temperature Transmitter must be installed in a suitably certified enclosure such that it is afforded a degree of protection of at least IP54 in accordance with IEC 60529 and EN 60079-15.

- ND** ATEX Dust
 Certificate: FM12ATEX0065X
 Standards: EN 60079-0: 2012, EN 60079-31: 2009, EN 60529:1991 +A1:2000
 Markings: Ⓔ II 2 D Ex tb IIIC T130 °C Db,
 (-40 °C ≤ T_a ≤ + 70 °C); IP66
 See [Table 5](#) at the end of the Product Certifications section for Process Temperatures

Special Conditions for Safe Use (X):

1. See certificate for ambient temperature range.
2. The non-metallic label may store an electrostatic charge and become a source of ignition in Group III environments.
3. Guard the LCD display cover against impact energies greater than 4 joules.
4. Consult the manufacturer if dimensional information on the flameproof joints is necessary.

Technical Regulations Customs Union (EAC)

- KM, IM, EM** Contact an Emerson Process Management representative for additional information.

International

- E7** IECEx Flameproof and Dust
 Certificate: IECEx FMG 12.0022X
 Standards: IEC 60079-0:2011, IEC 60079-1:2007-04, IEC 60079-31:2008
 Markings: Ex d IIC T6...T1 Gb, T6(-50 °C ≤ T_a ≤ +40 °C),
 T5...T1(-50 °C ≤ T_a ≤ + 60 °C); Ex tb IIIC T130 °C Db, (-40 °C ≤ T_a ≤ +70 °C); IP66;
 See [Table 5](#) at the end of the Product Certifications section for Process Temperatures

Special Conditions for Safe Use (X):

1. See certificate for ambient temperature range.
2. The non-metallic label may store an electrostatic charge and become a source of ignition in Group III environments.
3. Guard the LCD display cover against impact energies greater than 4 joules.
4. Consult the manufacturer if dimensional information on the flameproof joints is necessary.

I7 IECEx Intrinsic Safety
 Certificate: IECEx BAS 08.0011X
 Standards: IEC 60079-0:2011, IEC 60079-11:2011
 Markings: Ex ia IIC T5/T6 Ga, T5(-60 °C ≤ T_a ≤ + 80 °C),
 T6(-60 °C ≤ T_a ≤ + 60 °C);
 See Table [Table 6](#) at the end of the Product Certifications section for Entity Parameters

Special Condition for Safe Use (X):

1. The apparatus must be installed in an enclosure which affords it a degree of protection of at least IP20. Non-metallic enclosures must have a surface resistance of less than 1GΩ; light allow or zirconium enclosures must be protected from impact and friction when installed.

N7 IECEx Type n - with enclosure
 Certificate: IECEx BAS 07.0055
 Standards: IEC 60079-0:2011, IEC 60079-15:2010
 Markings: Ex nA IIC T5 Gc; T5(-40 °C ≤ T_a ≤ +70 °C)

NG IECEx Type n - without enclosure
 Certificate: IECEx BAS 13.0052X
 Standards: IEC 60079-0:2011, IEC 60079-15:2010
 Markings: Ex nA IIC T5/T6 Gc; T5(-60 °C ≤ T_a ≤ + 80 °C),
 T6(-60 °C ≤ T_a ≤ + 60 °C)

Special Condition for Safe Use (X):

1. The Model 148 Temperature Transmitter must be installed in a suitably certified enclosure such that it is afforded a degree of protection of at least IP54 in accordance with IEC 60529 and IEC 60079-15.

Combinations

K5 Combination of E5 and I5

Additional Specification Tables

Table 5. Process Temperatures

Temperature class	Ambient temperature	Process temperature w/o LCD display cover (°C)			
		No ext.	3-in.	6-in.	9-in.
T6	-50 °C to + 40 °C	55	55	60	65
T5	-50 °C to + 60 °C	70	70	70	75
T4	-50 °C to + 60 °C	100	110	120	130
T3	-50 °C to + 60 °C	170	190	200	200
T2	-50 °C to + 60 °C	280	300	300	300
T1	-50 °C to + 60 °C	440	450	450	450

Table 6. Entity Parameters

	HART loop terminals + and -	Sensor terminals 1 to 4
Voltage U _i	30 V	45 V
Current I _i	130 mA	26 mA
Power P _i	1 W	290 mW
Capacitance C _i	3.6 nF	2.1 nF
Inductance L _i	0 mH	0 μH

Rosemount World Headquarters

Emerson Process Management

6021 Innovation Blvd
Shakopee, MN 55379, USA
☎ +1 800 999 9307 or +1 952 906 8888
☎ +1 952 949 7001
✉ RFQ.RMD-RCC@EmersonProcess.com

North America Regional Office

Emerson Process Management

8200 Market Blvd.
Chanhassen, MN 55317, USA
☎ +1 800 999 9307 or +1 952 906 8888
☎ +1 952 949 7001
✉ RMT-NA.RCCRFQ@emerson.com

Latin America Regional Office

Emerson Process Management

1300 Concord Terrace, Suite 400
Sunrise, Florida, 33323, USA
☎ +1 954 846 5030
☎ +1 954 846 5121
✉ RFQ.RMD-RCC@EmersonProcess.com

Europe Regional Office

Emerson Process Management Europe GmbH

Neuhofstrasse 19a P.O. Box 1046
CH 6340 Baar
Switzerland
☎ +41 41 768 6111
☎ +41 (0) 41 768 6300
✉ RFQ.RMD-RCC@EmersonProcess.com

Asia Pacific Regional Office

Emerson Process Management Asia Pacific Pte Ltd

1 Pandan Crescent
Singapore 128461
☎ +65 6777 8211
☎ +65 6777 0947
✉ Enquiries@AP.EmersonProcess.com

Middle East and Africa Regional Office

Emerson Process Management

Emerson FZE P.O. Box 17033,
Jebel Ali Free Zone - South 2
Dubai, United Arab Emirates
☎ +971 4 8118100
☎ +971 4 8865465
✉ RFQ.RMTMEA@Emerson.com

Standard Terms and Conditions of Sale can be found at:
www.rosemount.com/terms_of_sale.

The Emerson logo is a trademark and service mark of Emerson Electric Co.
Rosemount and Rosemount logotype are registered trademarks of Rosemount Inc.
HART is a registered trademark of the HART Communication Foundation.
eurofast and minifast are registered trademarks of TURCK.
Microsoft is a registered trademark of Microsoft Corporation in the United States and other countries.
Windows is a trademark of Microsoft Corporation in the United States and other countries.

All other marks are the property of their respective owners.
© 2015 Rosemount Inc. All rights reserved.