

# System 103

*Loss-in Weight Dispensing Controls*

*Version 1.03*

## Operating Instructions





- 1.0 Introduction..... 1**
  - 1.1 Safety..... 1
  - 1.2 Overview..... 1
    - 1.2.1 Standard Features..... 2
  - 1.3 Operation Menu Softkeys..... 3
- 2.0 Installation..... 4**
  - 2.1 Unpacking and Assembly..... 4
  - 2.2 Enclosure Disassembly..... 4
  - 2.3 Cable Connections..... 4
  - 2.4 Cable Grounding..... 5
  - 2.5 Parts Kit Contents..... 5
  - 2.6 Option Cards..... 6
- 3.0 Setup Menu..... 7**
  - 3.1 Entering the Setup Menu..... 7
  - 3.2 Setting the System Time and Date..... 8
  - 3.3 Modifying the Setup Password..... 9
  - 3.4 Enabling/Disabling Additional Data Fields..... 9
  - 3.5 Modifying the Dispensing Speeds..... 10
  - 3.6 Modifying Auto Print..... 10
  - 3.7 Delay After Discharge..... 10
  - 3.8 Test Digital IO..... 11
- 4.0 Sequence of Operation..... 13**
  - 4.1 Entering Presets Softkey Menu..... 13
  - 4.2 Entering Totals Softkey Menu..... 16
  - 4.3 Dispensing Material from a Scale..... 18
  - 4.4 Pausing/Resume/Reset a Dispense..... 19
  - 4.5 Audit Trail Print..... 20
- 5.0 Appendix..... 21**
  - 5.1 Options..... 21
  - 5.2 Product Dimensions..... 22
  - 5.3 Replacement Parts..... 23
- Express 103 Limited Warranty..... 26**



Technical training seminars are available through Rice Lake Weighing Systems. Course descriptions and dates can be viewed at [www.ricelake.com/training](http://www.ricelake.com/training) or obtained by calling 715-234-9171 and asking for the training department.

© Rice Lake Weighing Systems. All rights reserved. Printed in the United States of America.  
Specifications subject to change without notice.  
Rice Lake Weighing Systems is an ISO 9001 registered company.  
Version 1.03 August 1, 2014



*Rice Lake continually offers web-based video training on a growing selection of product-related topics at no cost. Visit [www.ricelake.com/webinars](http://www.ricelake.com/webinars).*

# 1.0 Introduction

---

This manual is intended for use by service technicians and operators responsible for installing and operating the *Flexweigh System 103 Loss-in-Weight Controller*. Additional information on the actual hardware features of the 920i are explained in the 920i Installation and Operation manual (PN 67887) and is included with this product.

## 1.1 Safety

### Safety Symbol Definitions:



Indicates a potentially hazardous situation that, if not avoided could result in serious injury or death, and includes hazards that are exposed when guards are removed.



Indicates a potentially hazardous situation that, if not avoided may result in minor or moderate injury.



Indicates information about procedures that, if not observed, could result in damage to equipment or corruption to and loss of data.

### Safety Precautions



Do not operate or work on this equipment unless you have read and understand the instructions and warnings in this manual. Failure to follow the instructions or heed the warnings could result in injury or death. Contact any Rice Lake Weighing System dealer for replacement manuals. Proper care is your responsibility.

---

## General Safety

---



*Failure to heed may result in serious injury or death.*

*Some procedures described in this manual require work inside the indicator enclosure. These procedures are to be performed by qualified service personnel only.*

*DO NOT allow minors (children) or inexperienced persons to operate this unit.*

*DO NOT operate without all shields and guards in place.*

*DO NOT step on the unit.*

*DO NOT jump on the scale.*

*DO NOT use for purposes other than weight taking.*

*DO NOT place fingers into slots or possible pinch points.*

*DO NOT use any load bearing component that is worn beyond 5% of the original dimension.*

*DO NOT use this product if any of the components are cracked.*

*DO NOT exceed the rated load limit of the unit.*

*DO NOT make alterations or modifications to the unit.*

*DO NOT remove or obscure warning labels.*

*Before opening the unit, ensure the power cord is disconnected from the outlet.*

*Keep hands, feet and loose clothing away from moving parts.*

## 1.2 Overview

The *Flexweigh 103 Loss-in-Weight Controller* is designed for applications where a preset target weight is repeatedly dispensed from a tank or a hopper scale. The system maintains weight within high and low limits to guarantee enough content for a complete dispense cycle. Press Start and the system automatically tares the scale, begins the loss-in-weight dispense, and stops as programmed—all while transmitting and storing the accumulated weight totals.

## 1.2.1 Standard Features

The *System 103* comes with the following standard features:

- Wallmount NEMA 4X stainless steel enclosure
- Pre-programmed and configured *920i* HMI Indicator/Controller
- Front panel switches including E-Stop, Reset/Resume, Start
- Softkeys for presets, CN#, Alpha-numeric ID#1, Alpha-numeric ID#2, and Totals
- Built in safety interlocks prevent cycle start if not enough weight
- Accumulating subtotal and total registers
- Transmitted audit trail
- Digital I/O board
- Relay rack and SSR relay outputs
  - Fast feed
  - Slow feed
  - Dispense complete (optional)
- Automatic Discharge



**Note** *The iRite program and source code that make up the 920i Flexweigh 103 Loss-in-Weight Controller are property of the manufacturer. Modifications to this program and equipment must be performed by Rice Lake Weighing Systems.*

*For more information on the iRite compiler utility program, refer to the 920i Installation and Operation Manual (PN 67887) and is included with this product.*

### 1.3 Operation Menu Softkeys

Operation Menu softkeys are defined to provide flexibility of operator functions for specific applications. Softkey assignments are listed on the tabs shown at the bottom of the LCD display and softkey functions are activated by pressing the arrow keys below the softkey tabs (Figure 1-1). They are password protected and offer access to the following:

- Setup
- Totals
- Presets
- ID #1
- ID #2

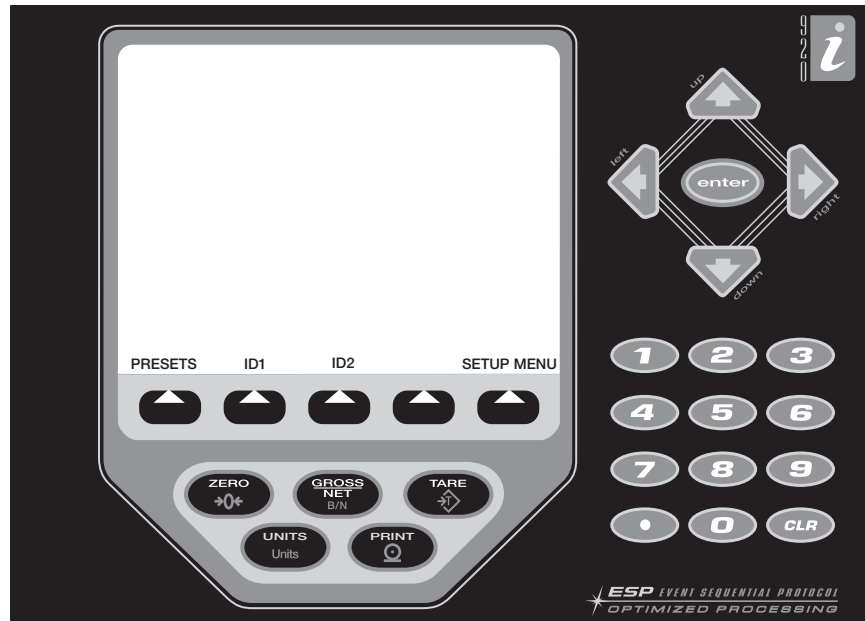

Figure 1-1. 920i Front Panel

The softkeys shown on the display are determined by the indicator configuration and program.

Softkey	Default	Softkey	Description
Time/Date	Current	Time/Date	Time and date of 920i
System Password	*****	Setup Password	Changing the password that is required for entry into the setup menu. Setting the password to nothing will cause the system to not prompt for a password when the Setup Menu softkey is pressed.
Enabling/Disabling ID#1	-	ID #1	This allows the operator to log an extra data field. A softkey will appear on the main screen to allow the operator to enter more data (ie: formula, ID Truck, container, operator)
Enabling/Disabling ID#2	-	ID #2	This allows the operator to log an extra data field. A softkey will appear on the main screen to allow the operator to enter more data (ie: formula, ID Truck, container, operator)
Dispensing Speeds	Single Speed	Single, Dual or Parallel	Allows the operator to change the dispense speed operations
Auto Tare Feature	Enabled	Auto Tare Enabled/Disabled	Allows the operator to enable/disable the auto tare feature
Auto Print Feature	Enabled	Auto Print Enabled/Disabled	Allows the operator to enable/disable the auto print feature
Delay After Discharge	-	Delay After Discharge	Allows the operator to enter a time in seconds to delay after completion of Discharge before a new Start input is enabled.

Table 1-1. Configurable Softkeys

# 2.0 Installation

This section describes procedures for setting up and getting the *System 103* ready to weigh.



**CAUTION** Use a wrist strap to ground yourself and protect components from electrostatic discharge (ESD) when working inside the indicator enclosure.

The supply cord serves as the power disconnect for the unit. The power outlet supplying the indicator must be installed near the unit and be easily accessible.



**WARNING** The Flexweigh System 103 Loss-in-Weight Dispensing Controller has no on/off switch. Before opening the unit, ensure the power cord is disconnected from the power outlet.

## 2.1 Unpacking and Assembly

Immediately after unpacking, visually inspect the unit to ensure all components are included and undamaged. The shipping carton should contain the *System 103* unit and this manual. If any parts were damaged in shipment, notify Rice Lake Weighing Systems and the shipper immediately.

## 2.2 Enclosure Disassembly

The *System 103* must be opened to install option cards and to connect cables for installed option cards.

Ensure power to the indicator is disconnected, then open the enclosure.

## 2.3 Cable Connections

The *System 103* provides eleven cord grips for cabling into the indicator. The parts kit includes cord grip plugs to prevent moisture from entering the enclosure. Install these plugs into all cord grips that will not be used in your application. Use the cable grounding instructions below for wiring into the indicator.

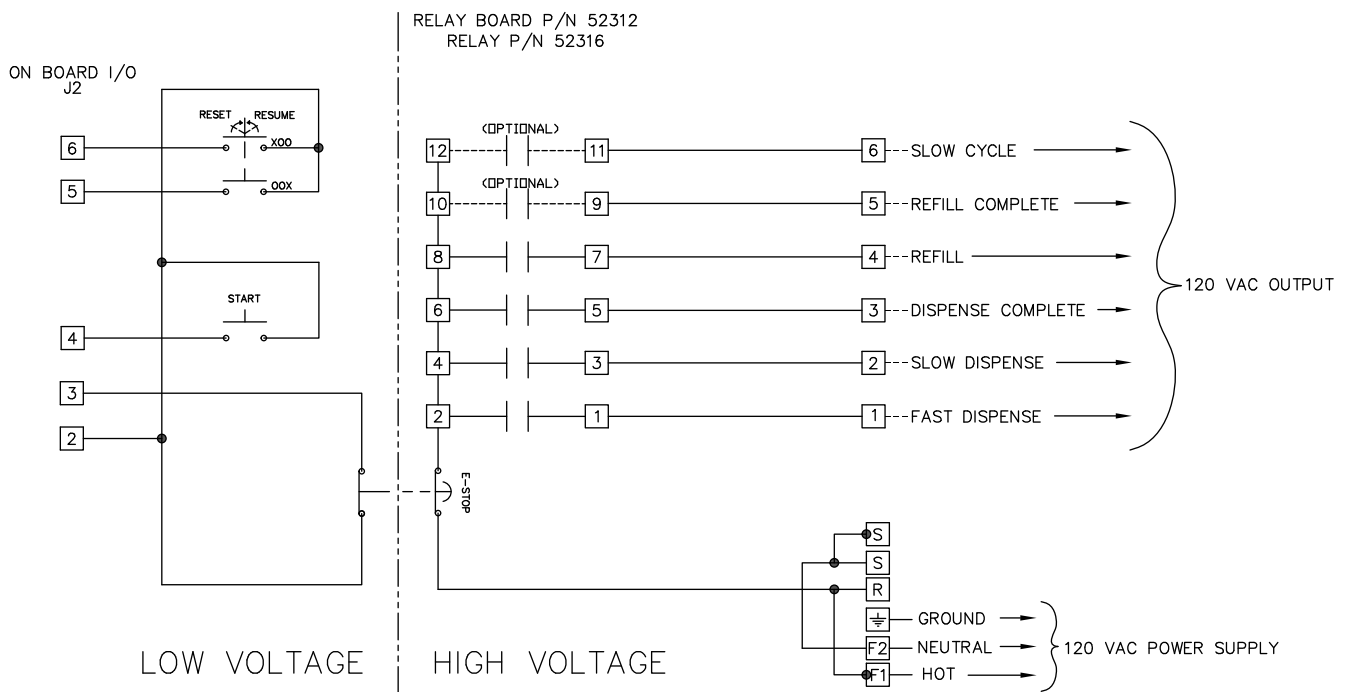

NOTE:  
FUSE F1 AND F2 = 3.15 AMPS SLO-BLO (5X20MM)

Figure 2-1. System 103 Block Wiring Diagram



Note

An additional adhesive label (124251) is included in the parts kit and can be installed at the installer's discretion indicating correct terminal block numbering.



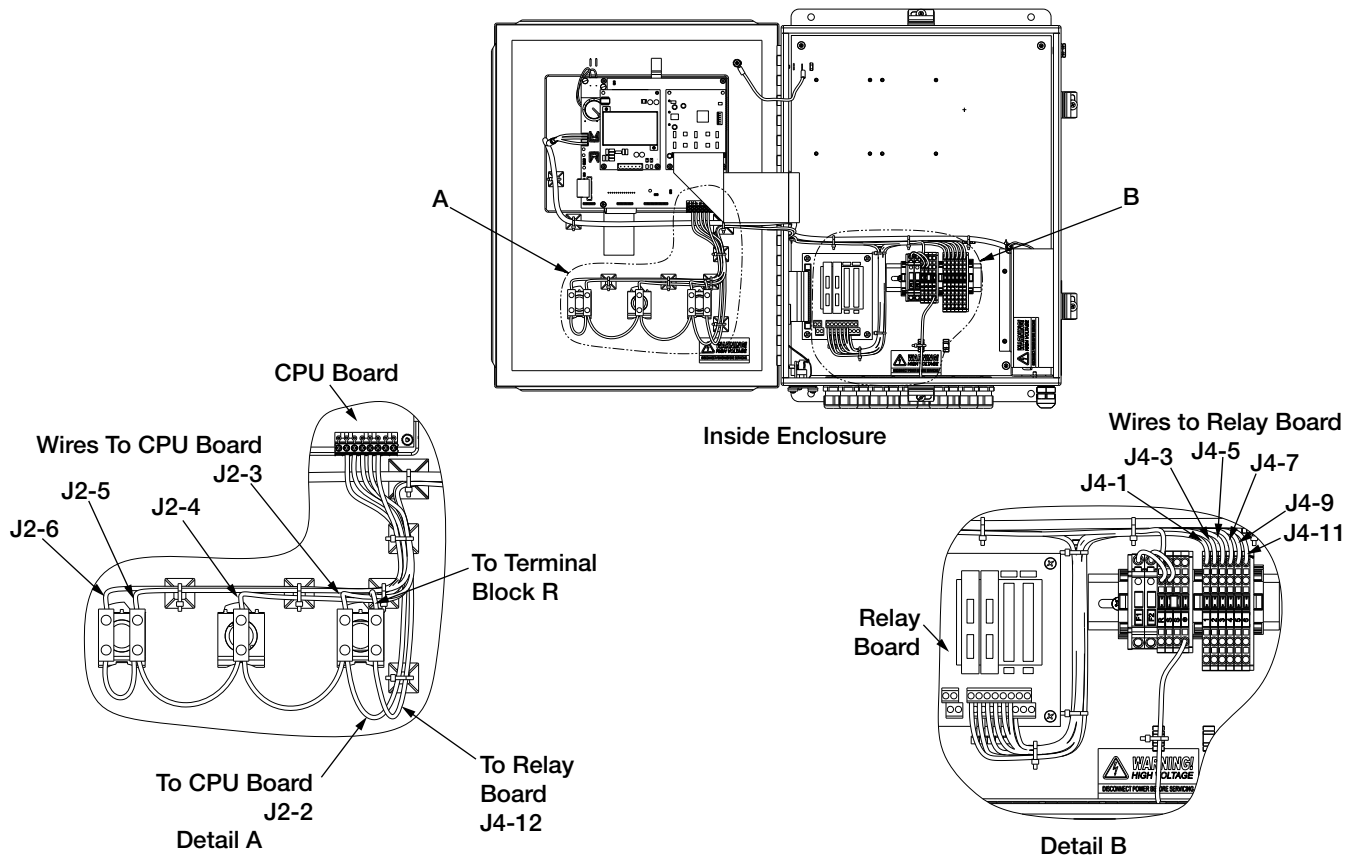

Figure 2-2. Wiring Diagram – Inside Enclosure

## 2.4 Cable Grounding

Cables routed through the cord grips should be grounded against the indicator enclosure. Follow cable grounding instructions in the *920i* Installation and Operation Manual (PN 67887) which is also included with this product.

## 2.5 Parts Kit Contents

Part No	Description	QTY
14626	Keyp nuts, 8-32NC (6)	6
15133	Lock washers, No. 8, type A (6)	6
15631	Cable ties (4 single A/D, 6 dual A/D)	4
15665	Reducing glands for 1/2 NPT cord grips (11)	11
15887	6-position screw terminal for load cell connection (1-single A/D, 2-dual A/D)	1
19538	Cord grip plugs (10-single A/D, 9-dual A/D)	10
94422	Capacity Label (1-single A/D, 2-dual A/D)	1
53075	Cable shield ground clamps (6)	6
70599	6-position screw terminals for J2 and J10 (2)	2
71125	3-position screw terminal for J11 (1)	1
71126	4-position screw terminal for J9 and optional keyboard connection (2)	2
121108	Label, Terminal Block Identification (1)	1

Table 2-1. Parts Kits Contents (PN 121143)



**Note** See Figure 5-1 for a complete list of replacement parts.

## 2.6 Option Cards

The single channel A/D card can be installed in slot 1 and the 24 channel I/O card in slot 2.

Slot	Type
1	Single Channel A/D Card
2	24 Channel I/O Card

Table 2-2. Option Card Locations

### Digital I/O

Slot	Bit	Type	Function
0	1	Programmability	E-Stop
0	2		Start
0	3		Resume
0	4		Reset
0	5-6	Off	Currently not used
2	1	Output Off	Fast Dispense
2	2		Slow Dispense
2	3		Dispense Complete
2	4		Refill
2	5		Refill Complete
2	6		Slow Cycle
2	7-24	Off	Currently not used

Table 2-3. Digital I/O Assignments

### Serial Ports

Port	Type	Description	Setup
1	CMD	Currently not used	9600 baud 8 bit None 2
2	CMD/KEYBOARD	iRev downloads/operator input	115200 8 bit None 2
3	CMD	Audit trail printer	9600 baud 8 bit None 2
4	CMD	Currently not used	9600 baud 8 bit None 2

Table 2-4. Serial Port Setup

# 3.0 Setup Menu

The *System 103* has various setup parameters. They are explained in further detail in the following sections.

## 3.1 Entering the Setup Menu



**Note** Note that the front panel *E-stop* button must be in the stopped position (pushed in) to enable any of the following keypad entries.

1. Press the **Setup Menu** softkey on the main menu screen and the system performs one of the following actions.
  - If a system password is entered, proceed to Step 2.
  - If no system password is entered, the **Setup Menu Main Screen** will display (see Figure 3-1).
2. Press the **Setup Password** softkey. The system prompts with **Enter Password**.

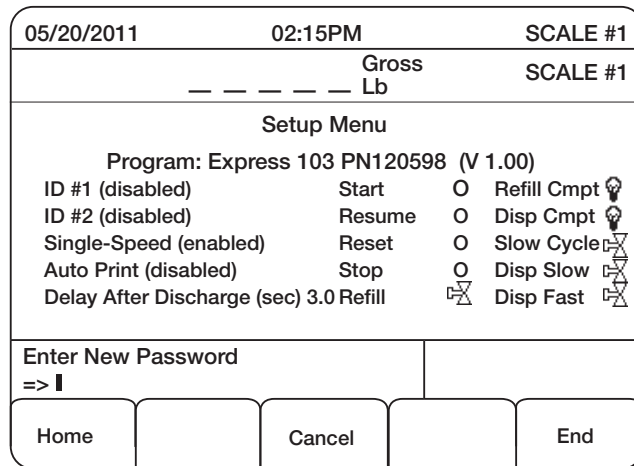

Figure 3-1. Setup Menu Enter Password

3. Enter the password and press the **enter** key on the *920i*. The system checks the entered value against the system password and performs one of the following actions:
  - If the password is valid the **Setup Menu Main Screen** will display (see Figure 3-2).
  - If the password is invalid, **Invalid password** will display momentarily and display exits the operation.

When the system password criteria is satisfied the following display is shown.

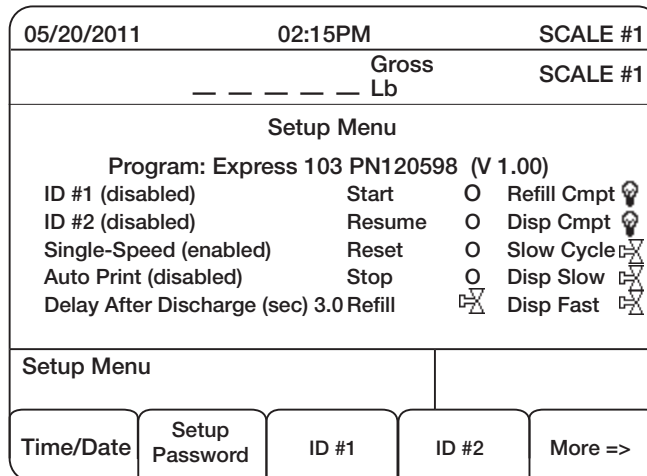

Figure 3-2. Setup Menu Main Screen

## 3.2 Setting the System Time and Date

Use the following steps to set up the system time and date.

1. From the *Main Setup Menu Screen*, press the *Time/Date* softkey.

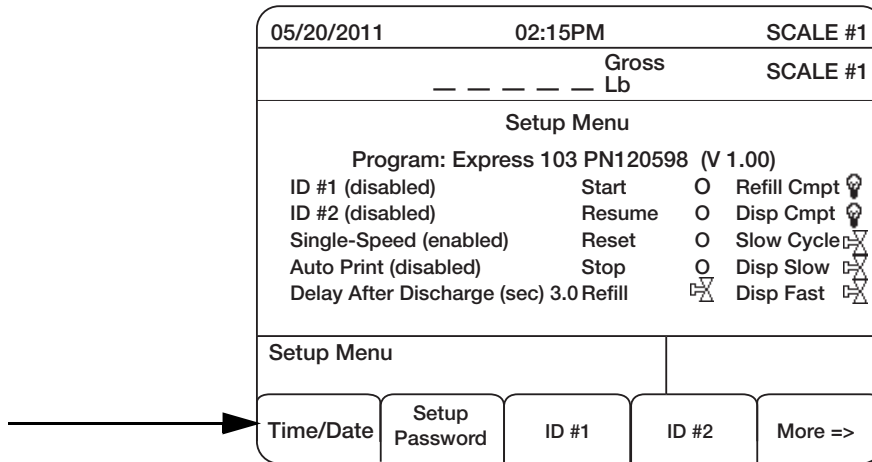

Figure 3-3. Select Time/Date Softkey

2. Use the arrow keys and the numeric keypad on the 920i (Figure 1-1 on page 3) to modify the time and or date.
3. Press the enter key to save your settings.

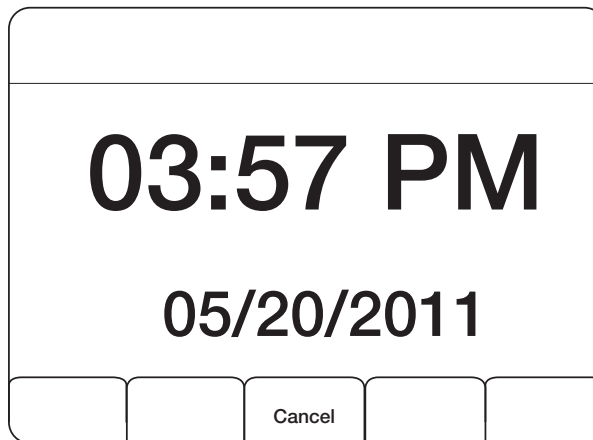

Figure 3-4. Time and Date Main Screen



**Note** The *Cancel* softkey can be pressed at any time to exit this sequence without saving any changes.

### 3.3 Modifying the Setup Password

Use the following steps to modify the setup password.

1. From the *Main Setup Menu Screen*, press the **Setup Password** softkey (Figure 3-2). The system prompts, *Enter New Password*.

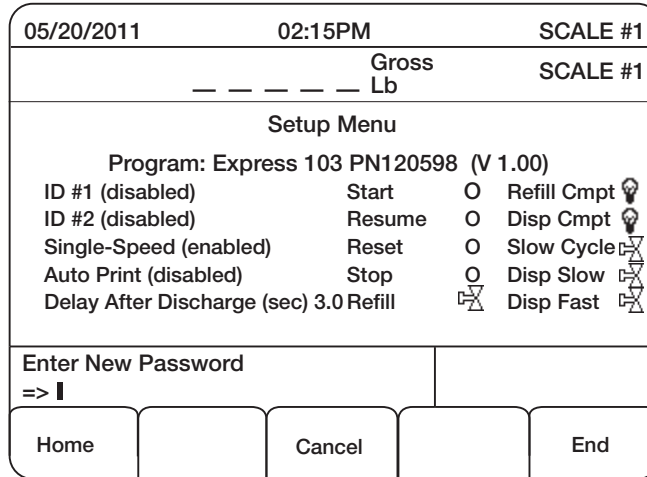

Figure 3-5. Enter New Password

2. Enter the new password and press the **enter** key. The system prompts *Re-enter password* to verify.
3. Re-enter the password and press the **enter** key again. The system performs one of the following actions.
  - If the passwords match, the system displays *Password Changed*.
  - If the passwords do not match, the system displays *Passwords Did Not Match* and exits the operation.

### 3.4 Enabling/Disabling Additional Data Fields

Use the following steps to enable or disable additional data fields.

1. From the *Main Setup Menu Screen*, press the **Setup Password** softkey (Figure 3-2).
2. Press the **ID #1** or **ID #2** softkey. The system displays *Enable Extra Data #1* or *Extra Data #2* while displaying **Yes** or **No** softkeys.

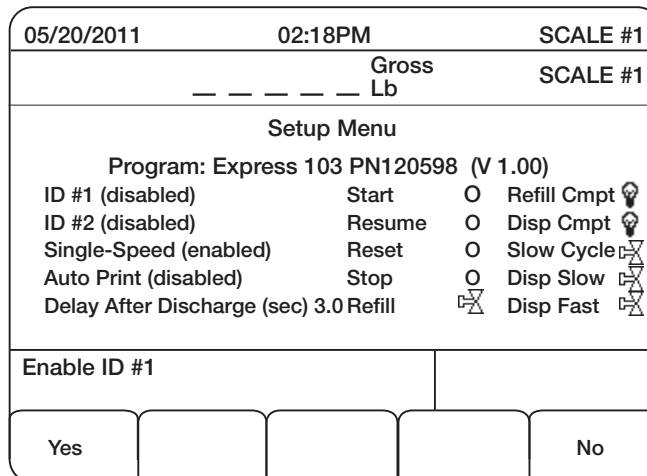

Figure 3-6. Enabling ID's

3. The operator does one of the following.

Press the **Yes** softkey, the system prompts *Enter ID#1 Name*. Enter the name using the alpha keypad (press the **UP** arrow to access), and press the **enter** key on the *920i*. A new data field appears on the main display and as a softkey so that the operator can change it.

Press the **Yes** softkey and this returns the operator back to Step 1.

### 3.5 Modifying the Dispensing Speeds

Use the following steps to modify the dispensing speeds.

1. From the *Main Setup Menu Screen*, press the **Setup Password** softkey (Figure 3-2).
2. Press the **More=>** softkey to access the second and third menu screens.

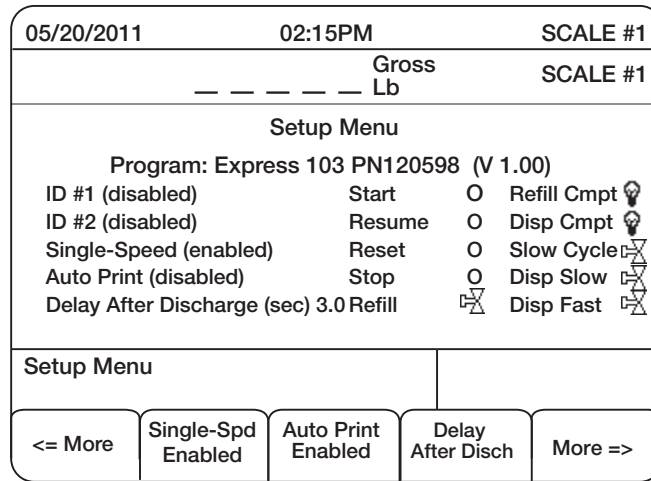

Figure 3-7. Setup Main Menu Screen #2

3. Press the **Single Speed Enabled**, **Dual Speed Enabled** or **Parallel Speed Enabled** softkey. The system will toggle between the three modes of operation.

### 3.6 Modifying Auto Print

Use the following steps to modify the auto print.

1. From the *Main Setup Menu Screen*, press the **More=>** softkey to access the second setup menu screen.
2. Press the **Auto Print Enabled** or **Auto Print Disabled** softkey. The system will toggle between the two modes of operation.



Figure 3-8. Auto Print Disabled Softkey

### 3.7 Delay After Discharge

Use the following steps to modify the delay after discharge.

1. Cycle through pressing the **More =>** softkey to access the second setup menu screen which includes the **Delay After Discharge** softkey.

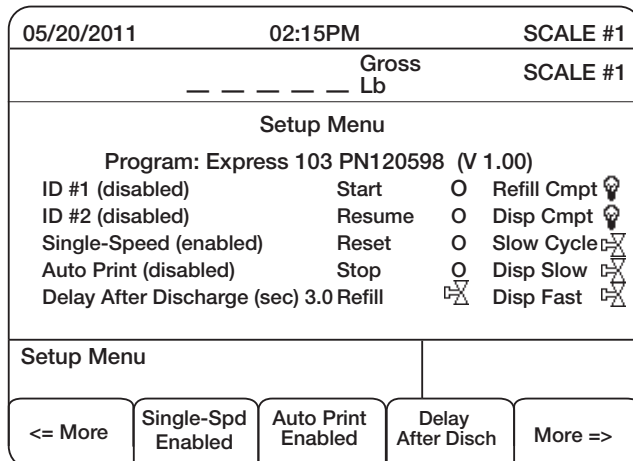

Figure 3-9. Delay After Discharge Softkey Location

2. Press the **Delay After Discharge** softkey to access that softkey.

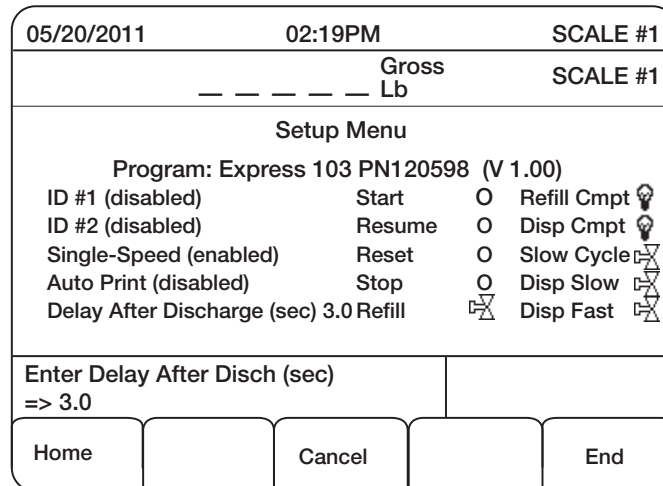

Figure 3-10. Enter Time

3. Enter in the time in seconds to delay the discharge time.

### 3.8 Test Digital IO

1. Cycle through pressing the **More =>** softkey to access the third setup menu screen which includes the **Delay After Discharge** softkey.
2. Press the **Test Digital IO** softkey to test the Dispense Complete, Slow Dispense and Fast Dispense relay outputs.

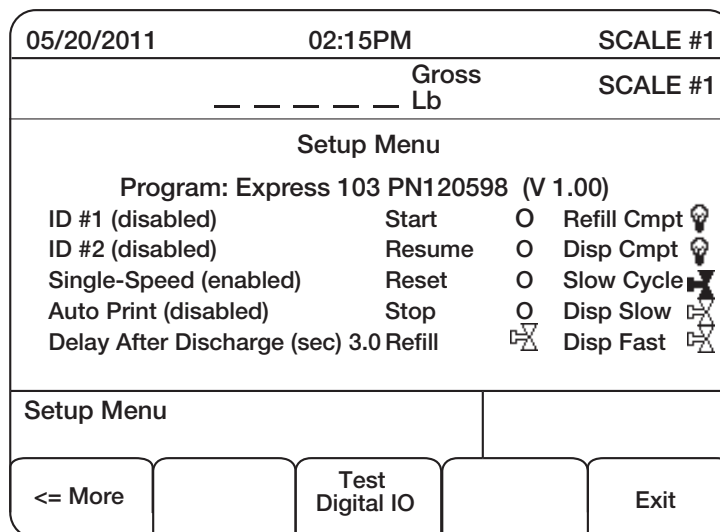



Figure 3-11. Test Digital I/O

#### Dispense Complete

Press the **Dispense Complete** softkey to test the digital I/O.

#### Slow Dispense

By pressing the **Slow Dispense** softkey, the digital I/O is tested and the **Slow Dispense** icon on the setup menu screen is darkened  while it's being tested. Press the **Slow Dispense** softkey again and the icon clears again.

#### Fast Dispense

By pressing the **Fast Dispense** softkey, the digital I/O is tested and the **Fast Dispense** icon on the setup menu screen is darkened  while it's being tested. Press the **Fast Dispense** softkey again and the icon clears again.

## Refill

By pressing the **Refill** softkey, the digital I/O is tested and the Refill icon on the setup menu screen is darkened  while it's being tested. Press the **Refill** softkey again and the icon clears again.

## Refill Complete

By pressing the **Refill Complete** softkey, the digital I/O is tested and the Refill Complete icon on the setup menu screen is darkened  while it's being tested.

## Slow Cycle

By pressing the **Slow Cycle** softkey, the digital I/O is tested and the Slow Cycle icon on the setup menu screen is darkened  while it's being tested.



## 4.0 Sequence of Operation

The following instructions explain a basic sequence of operation for the *System 103*.

### 4.1 Entering Presets Softkey Menu



**Note** Note that the front panel E-stop button must be in the stopped position (pushed in) to enable the following keypad entries.

The *System 103* has the capability to allow the operator to modify the presets/weights. Use the following instructions to do this.

05/20/2011		10:21AM		SCALE #1	
				Gross	SCALE
				Lb	#1
Target	Dribble	Preact	High Level	Low Level	
100.0 Lb	75	0.0	500 Lb	150 Lb	
Consec. #		Subtotal		Total	
2		0.0 Lb		3468 Lb	
Presets			Totals	Setup Menu	

Figure 4-1. Presets Menu Screen

1. Press the **Presets** softkey. The softkeys shown in Figure 4-2 are available.

05/20/2011		10:22AM		SCALE #1	
				Gross	SCALE
				Lb	#1
Target	Dribble	Preact	High Level	Low Level	
100.0 Lb	75	0.0	500 Lb	150 Lb	
Consec. #		Subtotal		Total	
2		0.0 Lb		0.0 Lb	
Target Weight	Dribble Weight	Preact Weight	More =>	Exit	

Figure 4-2. Presets Softkey Parameters

2. Press the corresponding softkey to edit the data. Parameters that can be edited include:
  - Target weight
  - Dribble weight
  - Preact weight
  - High level weight
  - Low level weight
  - Slow cycle time

## Target Weight

This is the desired weight value for a final dispense weight.

1. Enter the target weight using the arrow keys and the numeric keypad.
2. Press **enter** on the 920i to save that value.

05/20/2011		10:24AM		SCALE #1	
Gross Lb				SCALE #1	
Target	Dribble	Preact	High Level	Low Level	
100.0 Lb	75	0.0	500 Lb	150 Lb	
<b>Enter Target Weight</b>					
Consec. #		Subtotal		Total	
2		0.0 Lb		0.0 Lb	
Enter Target Weight => 100.0					
Home		Cancel		End	

Figure 4-3. Enter Target Weight

## Dribble Weight

When a 2-speed dispense is enabled (either Parallel or Sequential), this is the desired weight value below the Target Weight that the cycle switches from Fast Feed to Dribble Feed.

1. Enter the dribble weight using the arrow keys and numeric keypad.
2. Press **enter** on the 920i to save that value.

05/20/2011		10:25AM		SCALE #1	
Gross Lb				SCALE #1	
Target	Dribble	Preact	High Level	Low Level	
100.0 Lb	75	0.0	500 Lb	150 Lb	
<b>Enter Dribble Weight</b>					
Consec. #		Subtotal		Total	
2		0.0 Lb		0.0 Lb	
Enter Dribble Weight => 0.0					
Home		Cancel		End	

Figure 4-4. Enter Dribble Weight

## Preact Weight

Preact weight allows material to cut off prior to the original target value to allow for free fall material to settle onto the scale.

1. Enter the preact weight using the arrow keys and the numeric keypad.
2. Press **enter** on the 920i to save that value.

05/20/2011		10:27AM		SCALE #1	
<div style="display: flex; justify-content: space-between;"> <span>— — — — —</span> <span>Gross Lb</span> <span>SCALE #1</span> </div>					
Target	Dribble	Preact	High Level	Low Level	
100.0 Lb	75	0.0	500 Lb	150 Lb	
<b>Enter Preact Weight</b>					
Consec. #		Subtotal		Total	
2		0.0 Lb		0.0 Lb	
Enter Preact Weight => 0.0					
Home		Cancel		End	

Figure 4-5. Enter Preact Weight

## High Level Weight

This is the weight which the system dispenses material and considers the scale to be full. The scale weight must be above this value before the *System 103* will start a batch.

1. Enter the high level weight using the arrow keys and the numeric keypad.
2. Press **enter** on the 920i to save that value.

05/20/2011		10:27AM		SCALE #1	
<div style="display: flex; justify-content: space-between;"> <span>— — — — —</span> <span>Gross Lb</span> <span>SCALE #1</span> </div>					
Target	Dribble	Preact	High Level	Low Level	
100.0 Lb	75	0.0	500 Lb	150 Lb	
<b>Enter High Level Weight</b>					
Consec. #		Subtotal		Total	
2		0.0 Lb		0.0 Lb	
Enter High Level Weight => 500.0					
Home		Cancel		End	

Figure 4-6. High Level Weight

## Low Level Weight

After completing the first Dispense following a system power-up, if the displayed gross weight is below Low Level Weight, then the Refill output will automatically turn on until the gross weight exceeds High Level Weight. Starting a new dispense cycle will be inhibited during the time Refill output is on.

1. Enter the low level weight using the arrow keys and the numeric keypad.
2. Press **enter** on the 920i to save that value.



**Note** Entering a Low Level Weight of zero ("0") disables automatic refill upon Low Level.

## Slow Cycle Time

If a refill or dispense is not complete within the slow cycle time, the system will turn off all outputs and remain in a paused state.

1. Enter the desired slow cycle time using the arrow keys and the numeric keypad.
2. Press **enter** on the 920i to save that value.



**Note** Entering a timer value of zero (0) disables the Slow Cycle Timer function.

05/20/2011		10:27AM		SCALE #1	
Gross Lb				SCALE #1	
Target	Dribble	Preact	High Level	Low Level	
100.0 Lb	75	0.0	500 Lb	150 Lb	
Enter Cycle Time (sec)					
Consec. #		Subtotal		Total	
2		0.0 Lb		0.0 Lb	
Enter Cycle Time (sec)					
=> 12.0					
Home		Cancel		End	

Figure 4-7. Enter the Cycle Time

## Exit

Press the Exit softkey to leave the presets menu parameters.

## 4.2 Entering Totals Softkey Menu



**Note** Note that the front panel E-stop button must be in the stopped position to enable the following keypad entries.

05/20/2011		10:21AM		SCALE #1	
Gross Lb				SCALE #1	
Target	Dribble	Preact	High Level	Low Level	
100.0 Lb	75	0.0	500 Lb	150 Lb	
Consec. #		Subtotal		Total	
2		0.0 Lb		3468 Lb	
Presets			Totals	Setup Menu	

Figure 4-8. Printing and Clearing Accumulators Menu

1. Press the **Totals** softkey.
2. The operator can print and reset the consecutive number, subtotal and totals by pressing the appropriate softkey. Parameters that can be edited include:
  - Consecutive Number
  - Print Sub Total
  - Print Total

## Consecutive Number

1. Press the **Consecutive Number** softkey to enter the next number to be weighed. The system keeps incrementing every time a batch is running (counter).

05/20/2011		10:22AM		SCALE #1	
■ ■ ■ ■ ■ Gross Lb				SCALE #1	
Target	Dribble	Preact	High Level	Low Level	
100.0 Lb	75	0.0	500 Lb	150 Lb	
<b>Enter Consecutive Number</b>					
Consec. #		Subtotal		Total	
2		0.0 Lb		0.0 Lb	
Enter Consecutive Number => 2					
Home		Cancel		End	

Figure 4-9. Enter Consecutive Number

## Print Sub Total

1. Press the **Totals** softkey (Figure 4-8) to access the **Print Sub Total** softkey.
2. Press the **Print Sub Total** softkey to access the following screen.

05/20/2011		10:29AM		SCALE #1	
■ ■ ■ ■ ■ Gross Lb				SCALE #1	
Target	Dribble	Preact	High Level	Low Level	
100.0 Lb	75	0.0	500 Lb	150 Lb	
<b>Clear Sub Total?</b>					
Consec. #		Subtotal		Total	
2		0.0 Lb		0.0 Lb	
Yes				No	

Figure 4-10. Clear Sub Total Screen

3. Press the **Yes** softkey to clear the subtotal of the batch.  
Press the **No** softkey to exit out of the screen.

## Print Total

1. Press the **Totals** softkey (Figure 4-8) to access the **Print Total** softkey.
2. Press the **Print Total** softkey to access the following screen.

05/20/2011		10:31AM		SCALE #1	
				Gross	SCALE
				Lb	#1
Target	Dribble	Preact	High Level	Low Level	
100.0 Lb	75	0.0	500 Lb	150 Lb	
Clear Total?					
Consec. #		Subtotal		Total	
2		0.0 Lb		0.0 Lb	
Yes					No

Figure 4-11. Clear Total Screen

3. Press the **Yes** softkey to clear the total and sub-total of the batch. Press the **No** softkey to exit out of the screen.

## 4.3 Dispensing Material from a Scale

1. Press the **Start** button on the unit. The system verifies if:
  - E-Stop is pulled out
  - A valid target weight is entered

The system verifies the weight to make sure it's above the target weight and above the low level weight. If the weight is below the low level weight, it will refill the scale to the high level weight. When the weight reaches the high level weight, the refill output will turn off.

2. Press the **START** button to start the dispensing material.

The system does the following during this process.

- Turns off the Dispense Complete and Refill Complete outputs
- Increments the consecutive number by one
- Tares the scale to zero (net mode)

The system begins dispensing either of three speeds while the 920i screen displays real time sequence progress. The displayed net weight will continue showing more negative as weight is dispensed, until the target weight presets are achieved.

05/20/2011		10:28AM		SCALE #1	
<b>250</b>			Gross Lb		SCALE #1
<b>Target</b>	<b>Dribble</b>	<b>Preact</b>	<b>High Level</b>	<b>Low Level</b>	
100.0 Lb	75	0.0	500 Lb	150 Lb	
<b>Fast Dispense</b>					
<b>Consec. #</b>		<b>Subtotal</b>		<b>Total</b>	
2		120 Lb		3200 Lb	

Figure 4-12. Dispense Screen

The three dispensing speeds include:

- Single speed dispensing - The system turns on fast dispense until the target weight/preact weight is satisfied.
- Parallel speed dispensing - Turns on the fast dispense and slow dispense until the dribble weight is satisfied. The system then turns off the fast dispense and leaves the slow dispense on until the target weight/preact weight is satisfied.
- Dual speed dispensing - Turns on the fast dispense until the dribble weight is satisfied. The system turns on the slow dispense until the target weight/preact weight is satisfied.

The system does the following when the target/preact is reached.

- Turns off the output based on the dispensing mode
- Update the subtotal weight and number of dispenses
- Updates the total and number of dispenses
- Turns on the Dispense Complete output

The system delays for the Delay After Dispense time. After the delay, the weight display then switches to gross weight and:

- If the gross weight is below low level weight the Refill output will automatically turn on until the gross weight exceeds the high level weight.
- If the gross weight is above low level weight system, the system resets for the next cycle beginning with Step #1.

#### 4.4 Pausing/Resume/Reset a Dispense

1. Press the E-Stop button. System turns off all outputs and displays **System Paused**.
2. Press the **Resume** switch to resume where the current batch left off.  
Press the **Reset** switch to return back to Step 1 to start over.

## 4.5 Audit Trail Print

Record keeping is an important part of any system. The *System 103* has the ability to be connected to a printer for retaining detailed records on batches, cycle runs, cycle paused, etc.

The preferred printer to integrate with the *System 103* is the *TMU-220 Ticket Printer* but will easily integrate with any strip printer.

Hook up the printer to the *System 103* per printer manual instructions.

Shown below are tape samples that can be printed using the *System 103* and the *TMU-220 Ticket Printer*.

```

Start Cycle  6 04:31PM 04/27/2011
Id AB123 Location Rice Lake

End Cycle
111.2 lb  04:31PM 04/27/2011

Start Cycle  7 04:32PM 04/27/2011
Id AB123 Location Rice Lake

Cycle Stopped 04:32PM 04/27/2011

Cycle Resumed 04:32PM 04/27/2011

End Cycle
116.0 lb  04:32PM 04/27/2011

Start Cycle  8 04:32PM 04/27/2011
Id AB123 Location Rice Lake

Cycle Stopped 04:32PM 04/27/2011

Cycle Reset  04:32PM 04/27/2011
    
```

**Batch Stopped & Resume & Reset Print**

```

Sub Total      04:32PM 04/27/2011
Id AB123 Location Rice Lake
7 cycles      755.8 lb
    
```

**Sub Total Printout**

```

Total          04:34PM 04/27/2011
Id AB123 Location Rice Lake
9 cycles      1022.9 lb
    
```

**Total Printout**

```

Start Cycle  1 04:03PM 04/27/2011

End Cycle
111.1 lb  04:03PM 04/27/2011

Start Cycle  2 04:03PM 04/27/2011

End Cycle
104.9 lb  04:03PM 04/27/2011
    
```

**No Extra ID Fields Running Batch Print**

```

Start Cycle  3 04:07PM 04/27/2011
Id AB123 Location Rice Lake

End Cycle
100.7 lb  04:07PM 04/27/2011

Start Cycle  4 04:07PM 04/27/2011
Id AB123 Location Rice Lake

End Cycle
109.1 lb  04:07PM 04/27/2011

Start Cycle  5 04:07PM 04/27/2011
Id AB123 Location Rice Lake

End Cycle
102.8 lb  04:08PM 04/27/2011
    
```

**2 Extra ID Fields Running Batch Printout**

*Figure 4-13. Tape Printer Examples*



## 5.0 Appendix

---

### 5.1 Options

Several options are available with the *System 103*. Those options that are available include:

- Three Position Selector Switch
- Manual-Mode Front Panel Controls
- Optional Front Panel Pilot Lights

#### **Three Position Selector Switch**

Includes:

- Manual/Off/Auto

#### **Manual Mode Front Panel Push Button**

Includes:

- Manual Dispense

#### **Maintained Return Buttons**

- Dispense - On/Jog
- Dispense - Fast/Slow
- Refill - On/Jog

#### **Optional Front Panel Event Pilot Lights**

Includes:

- Amber Dispense
- Amber Dispense Fast
- Amber Dispense Slow
- Red Dispense Complete
- Blue Refilling
- Red Refill Complete
- Red Low Supply
- Red Fill Time Alarm

## 5.2 Product Dimensions

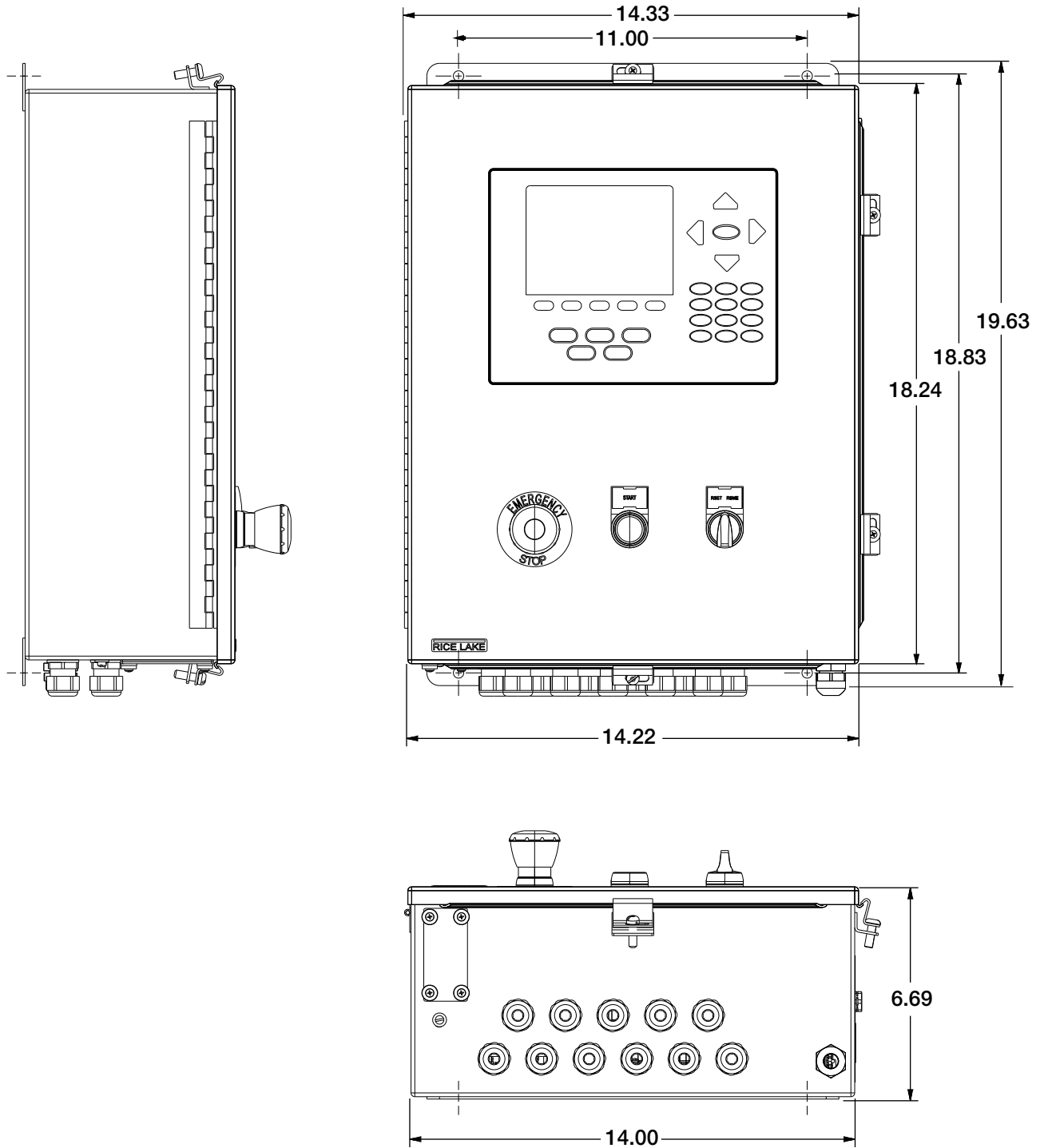

Figure 5-1. Enclosure Dimensions

### 5.3 Replacement Parts

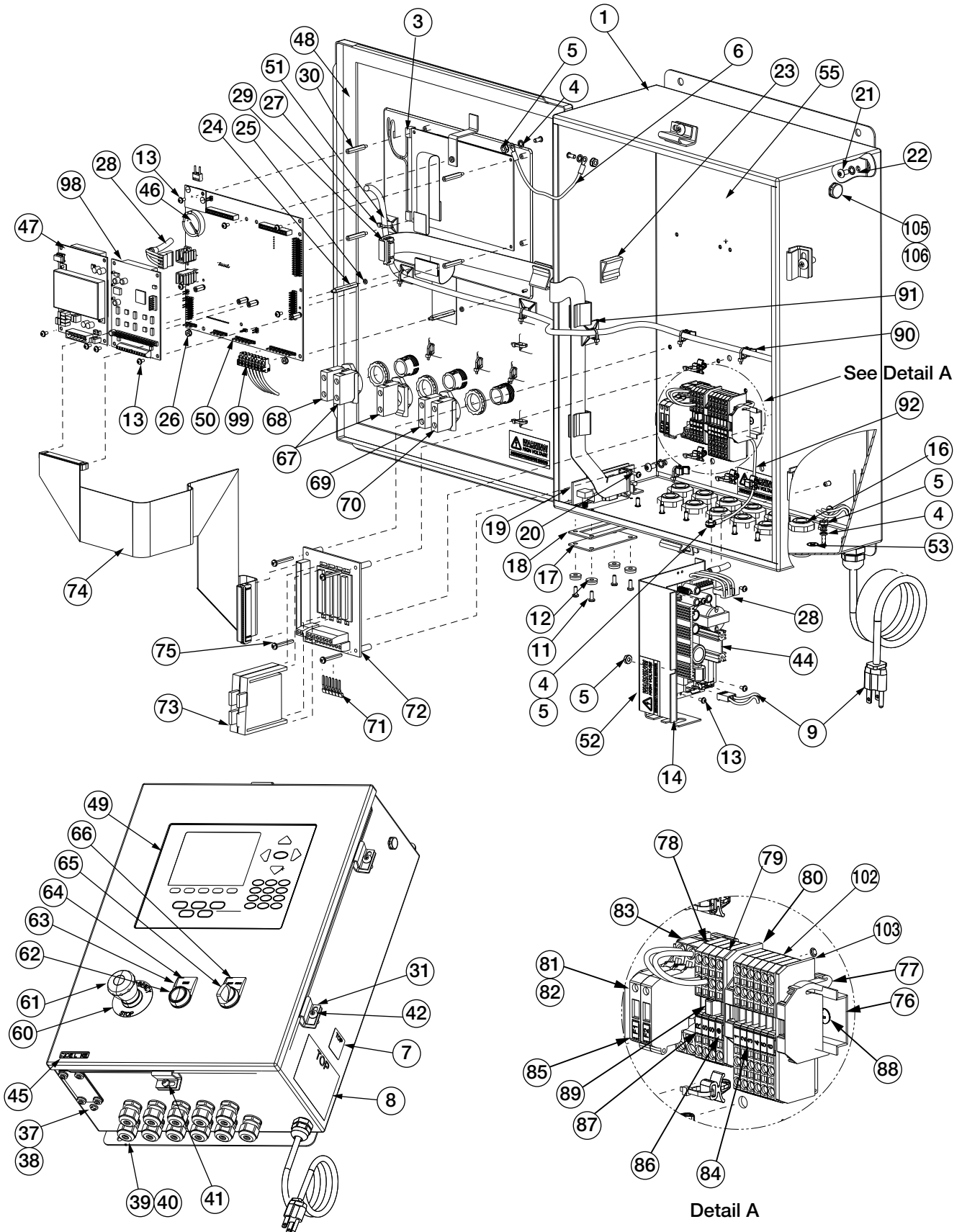

Figure 5-2. Replacement Parts Illustration

Item No	Part No	Description (Quantity)	Qty
1	120417	Enclosure, Wall Mount	1
3	67614	Display, LCD Module, 920i	1
4	15134	Lock Washers, No 8, Type A	4
5	14626	Kep Nuts, 8-32NC Hex	4
6	15601	Ground Wire, 6 in w/No. 8	1
7	53308	Label, 1.25 x 1.25 8000T	1
8	53307	Label, 4.000 x 2.875	1
9	85202	Power Cord Assembly, 120 VAC	1
11	14845	Machine Screws, 6-32NC x 3/8	8
12	45042	Washer, Bonded Sealing SS	8
13	14822	Machine Screws, 4-40NC x 1/4	13
14	69538	Power Supply Bracket	1
16	15630	Locknuts, 1/2 NPT Black	11
17	67530	Interface Board Plate	1
18	67535	Interface Board Gasket	1
19	67869	920i Inteface Board	1
20	55708	Machine Screws, 4-40NC x 3/8	2
21	14875	Machine Screws, 10-32NF x 3/8	4
22	15140	Lock Washer, No. 10, Type A	4
23	46192	Flat Ribbon Cable Clamp	4
24	68661	Standoffs, Male-FEM, 4-40NC	2
25	69898	Nylon Washer ID 0.112	2
26	14618	Kep Nuts, 4-40NC Hex	2
27	15631	Cable Tie, 3 in Nylon	18
28	71431	Cable Assembly, 65W power	1
29	71436	Ribbon Cable Assembly, 28 in	1
30	67886	Standoffs, Long, Male 4-40NC	4
31	71739	Cinching Enclosure Clip	4
37	42640	Machine Screw, 1/4 - 28NF x 1	1
38	59250	Washer, .255 ID x .437 OD	1
39	30376	Sealing Ring, 1/2 NPT, Nylon	11
40	15628	Cord Grip, 1/2 NPT, Black	11
41	71455	Machine Screws, 1/4-28NF x .75	1
42	71447	Machine Screws 1/4-28NF	3
44	71333	920i Power Supply Board	1
45	68216	Metal Nameplate	1
46	69290	3V Coin Lithium Batter	1
47	67610	Single Channel A/D Card	1
48	68724	920i Cover Gasket	1
49	66502	Overlay, Membrane Switch	1
50	109549	920i CPU Board Assembly	1
51	15650	Cable Tie Mount 3/4 in	7
52	16861	Label, High Voltage	3

Item No	Part No	Description (Quantity)	Qty
53	16892	Label, Earth Ground	1
55	120423	Back Panel Component	1
60	94274	Legend Plate, Emergency Stop	1
61	94273	Red Mushroom Switch	1
62	94277	Switch, Push Button Green	1
63	94316	Legend Plate Holder	2
64	114695	Legend Plate, Start	1
65	94298	3-Position Switch	1
66	120728	Legend Plate, Reset/Resume	1
67	94310	Contact Block	2
68	94311	Contact Block, Switch On	1
69	94312	Contact Block, Switch On	1
70	94313	Contact Block, Switch On	1
71	46189	10 Position Jumper Strap	1
72	52312	8-Channel Mounting Relay Board	1
73	52316	Output Relay Module	2
74	70780	50 Pin Flat Ribbon Cable	1
75	120762	Machine Screw, 6-32NC x 1 - 1/4	4
76	43636	DIN Rail	1
77	61141	Screwless WAGO End Stop	3
78	62964	WAGO Terminal Block	7
79	62966	WAGO Terminal Block	1
80	62968	Intermediate End Plate	3
81	62969	WAGO Fuse Terminal Block	2
82	54215	Time Delay Fuse, 3.15 amp	2
83	66190	Intermediate End Plate	1
84	62959	Label, WAGO Terminal Strip	1
85	65007	Label, WAGO Terminal Block	1
86	62967	Label, WAGO Terminal Block	1
87	66034	Label, WAGO Terminal Block	1
88	22087	Machine Screw, 6-32NC x 3/8	2
89	55337	Jumper, Series 280, Insulated	1
90	80590	Arrowhead Cable Tie Mount	8
91	15658	1 Inch Cable Tie Mount	2
92	121069	9 Inch Ground Assembly Wire	1
98	67608	Card, Digital I/O	1
99	77180	Conn, 8 Pos Screw Terminal	1
102	62975	Plate, End Intermediate	1
103	62973	Block, Terminal WAGO 4	6
105	88733	Vent, Breather Sealed	1
106	88734	Nut, Breather Vent	1
NS	54215	Fuse Between Din Rail/Relay Rack	1
NS	117901	Foam, Mixture High Density	1

Table 5-1. Replacement Parts List

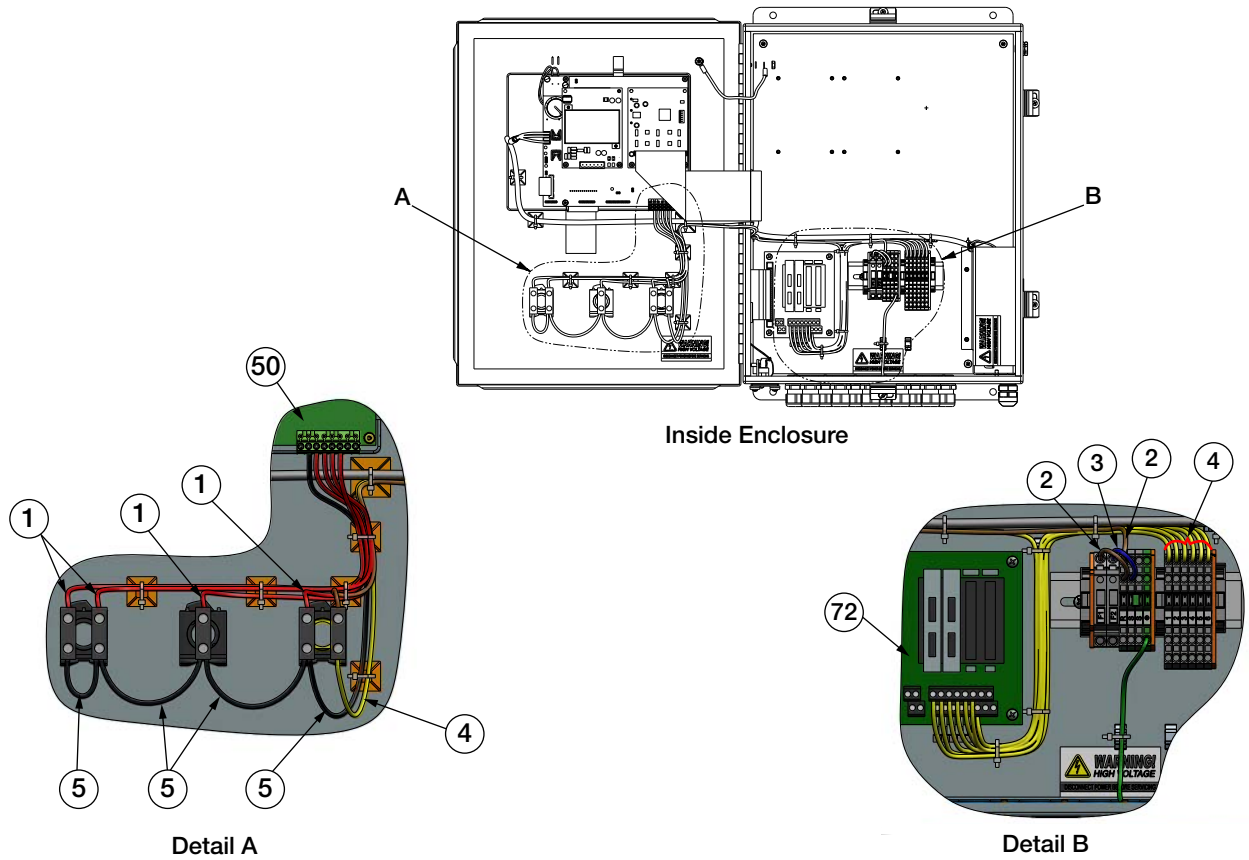

Figure 5-3. Interior Wiring Parts Illustration

Item No	Part No	Description (Quantity)	Qty
1	15433	Wire, 18 AWG, Red Stranded	4 ft
2	15432	Wire, 18 AWG, Brown Stranded	2.5 ft
3	15435	Wire, 18 AWG, Blue Stranded	.33 ft
4	15451	Wire, 18 AWG Yellow Stranded	8 ft
5	15431	Wire, 18 AWG Black Stranded	2ft
50	109549	920i CPU Board Assembly	1
72	52312	8-Channel Mounting Relay Board	1

Table 5-2. Interior Wiring Parts List

# Express 103 Limited Warranty

Rice Lake Weighing Systems warrants that all Rice Lake Weighing Systems equipment and systems properly installed by a Distributor or Original Equipment Manufacturer (OEM) will operate per written specifications as confirmed by the Distributor/OEM and accepted by Rice Lake Weighing Systems. All systems and components are warranted against defects in materials and workmanship for two years.

Rice Lake Weighing Systems warrants that the equipment sold hereunder will conform to the current written specifications authorized by Rice Lake Weighing Systems. Rice Lake Weighing Systems warrants the equipment against faulty workmanship and defective materials. If any equipment fails to conform to these warranties, Rice Lake Weighing Systems will, at its option, repair or replace such goods returned within the warranty period subject to the following conditions:

- Upon discovery by Buyer of such nonconformity, Rice Lake Weighing Systems will be given prompt written notice with a detailed explanation of the alleged deficiencies.
- Individual electronic components returned to Rice Lake Weighing Systems for warranty purposes must be packaged to prevent electrostatic discharge (ESD) damage in shipment.
- Examination of such equipment by Rice Lake Weighing Systems confirms that the nonconformity actually exists, and was not caused by accident, misuse, neglect, alteration, improper installation, improper repair or improper testing; Rice Lake Weighing Systems shall be the sole judge of all alleged non-conformities.
- Such equipment has not been modified, altered, or changed by any person other than Rice Lake Weighing Systems or its duly authorized repair agents.
- Rice Lake Weighing Systems will have a reasonable time to repair or replace the defective equipment. Buyer is responsible for shipping charges both ways.
- In no event will Rice Lake Weighing Systems be responsible for travel time or on-location repairs, including assembly or disassembly of equipment, nor will Rice Lake Weighing Systems be liable for the cost of any repairs made by others.

**THESE WARRANTIES EXCLUDE ALL OTHER WARRANTIES, EXPRESSED OR IMPLIED, INCLUDING WITHOUT LIMITATION WARRANTIES OF MERCHANTABILITY OR FITNESS FOR A PARTICULAR PURPOSE. NEITHER RICE LAKE WEIGHING SYSTEMS OR DISTRIBUTOR WILL, IN ANY EVENT, BE LIABLE FOR INCIDENTAL OR CONSEQUENTIAL DAMAGES.**

**RICE LAKE WEIGHING SYSTEMS AND BUYER AGREE THAT RICE LAKE WEIGHING SYSTEMS'S SOLE AND EXCLUSIVE LIABILITY HEREUNDER IS LIMITED TO REPAIR OR REPLACEMENT OF SUCH GOODS. IN ACCEPTING THIS WARRANTY, THE BUYER WAIVES ANY AND ALL OTHER CLAIMS TO WARRANTY.**

**SHOULD THE SELLER BE OTHER THAN RICE LAKE WEIGHING SYSTEMS, THE BUYER AGREES TO LOOK ONLY TO THE SELLER FOR WARRANTY CLAIMS.**

**NO TERMS, CONDITIONS, UNDERSTANDING, OR AGREEMENTS PURPORTING TO MODIFY THE TERMS OF THIS WARRANTY SHALL HAVE ANY LEGAL EFFECT UNLESS MADE IN WRITING AND SIGNED BY A CORPORATE OFFICER OF RICE LAKE WEIGHING SYSTEMS AND THE BUYER.**

© Rice Lake Weighing Systems, Inc. Rice Lake, WI USA. All Rights Reserved.

RICE LAKE WEIGHING SYSTEMS • 230 WEST COLEMAN STREET • RICE LAKE, WISCONSIN 54868 • USA





230 W. Coleman St. • Rice Lake, WI 54868 • USA  
U.S. 800-472-6703 • Canada/Mexico 800-321-6703 • International 715-234-9171 • Europe +31 (0) 88 2349171

---

**[www.ricelake.com](http://www.ricelake.com) [www.ricelake.mx](http://www.ricelake.mx) [www.ricelake.eu](http://www.ricelake.eu) [www.ricelake.co.in](http://www.ricelake.co.in) [m.ricelake.com](http://m.ricelake.com)**