

RXi2 – BP Industrial PC

QUICK START GUIDE



Contents

- Physical Connection Overview and Startup..... 1**
 - Power-Input 1
 - Ethernet Ports..... 1
 - Initial Startup..... 1
- RXi2-BP Pre-Installed Software Options..... 2**
- PACEdge Startup 2**
 - PACEdge Usage Model..... 2
 - Getting Started 3
 - First Login 3
- Mounting Information..... 4**
 - DIN Rail Mounting..... 4
 - DIN Rail Mounting Options 5
 - Panel Mounting..... 6
 - Clearances Requirements for all Mounting Options 7

Physical Connection Overview and Startup

Power-Input

RXi2-BP can be powered with a DC power supply with 24V (+-25%) and at least delivering 1.8A.

The corresponding plug is a Phoenix Contact, part number 1748367. User must use the same connector type or equivalent.

Figure 1: Power Connector

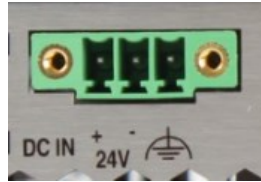

Signal Name	Pin (left to right)
Power + (24V DC)	1
Power - (24V DC)	2
FGND	3

Ethernet Ports

RXi2-BP provides four Ethernet ports, three RJ45 on the front panel and one at the bottom of the IPC.

All Ethernet support 10/100/1000 Base-T.

For a proper 100/1000 Mbit connection, Emerson recommends a CAT5 cable.

Figure 2: Ethernet Ports

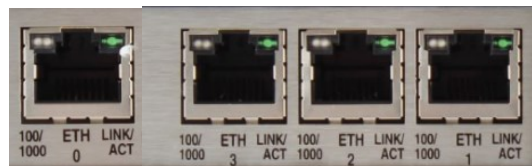

Initial Startup

After making the connection, power-on the IPC. A few seconds after powering up, the RXi2-BP IPC system UEFI Firmware banner will display on the screen. If you do not see any error messages up to this point, the RXi2-BP IPC is running properly and ready to be configured for your application.

For more information on UEFI Setup, please see the RXi2-BP Hardware Reference Manual (GFK-3187).

Note: If the RXi2-BP IPC does not perform as described above, some damage may have occurred during shipment, or the board is not installed or configured properly. Contact Emerson for technical support. (Refer to the section Contact Information.)

RXi2-BP Pre-Installed Software Options

Software Options	Descriptions
RXi2-BP (No Pre-Installed Software)	The user is responsible for installing an operating system and application software. Please consult RXi2-BP Hardware Reference manual (GFK-3187) for details on how to change the UEFI boot order and install the operating system.
RXi2-BP Windows 10	The unit comes with a Windows 10 IoT operating system pre-installed. Please connect power, monitor and USB keyboard and mouse, power up system and follow on-screen instructions for configuring Windows OS.
RXi2-BP PACEdge.	Unit comes with PACEdge software pre-installed. Please consult following section for details.

PACEdge Startup

This section applies to the units pre-installed with the PACEdge only.

PACEdge Usage Model

PACEdge software is designed to run on the Industrial PC which is operating in a headless mode, with user accessing it remotely via Ethernet a using web interface.

Figure 3: PACEdge Usage Model

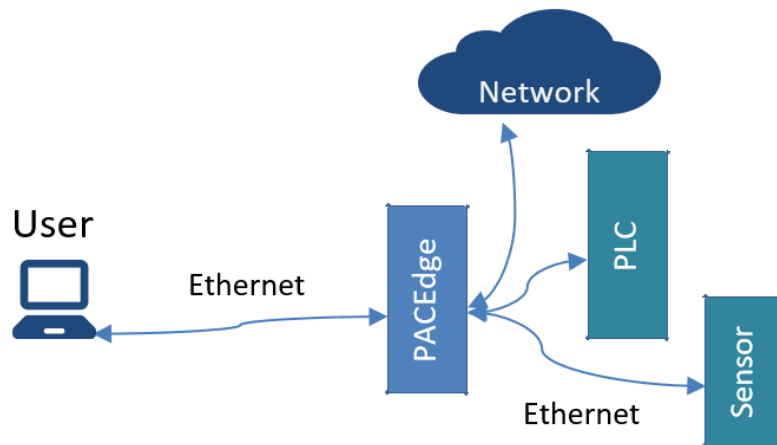

Getting Started

1. Connect the Ethernet cable to Ethernet port labeled ETH0 next to the 24 V power connector on the RXi2-BP.
2. Connect the 24 V +/-25% power plug.
3. Setup the User PC Ethernet port IP address to be statically assigned as follows:
 - a. Pv4 Static IP: 192.168.3.10 (or similar in the same subnet)
 - b. Netmask: 255.255.255.0
4. Power up the PACEdge unit and wait until it boots.
5. Open the browser of your choice and type in **192.168.3.100**.
6. Note: all Ethernet ports are also configured to get IP addresses assigned by the DHCP server. This dynamically assigned IP address can also be used to access PACEdge.

First Login

The first time you connect a warning message stating that the identity of the device could not be confirmed will be shown. Please click on Advanced and Accept to proceed (this is due to self-signed certificate on the unit)

Please read and accept the Emerson End User License Agreement.

Shortcuts to Cockpit, Node-RED, Grafana, Portainer, and Chronograf will be shown on the PACEdge Landing Page (

Figure 4: PACEdge Landing Page

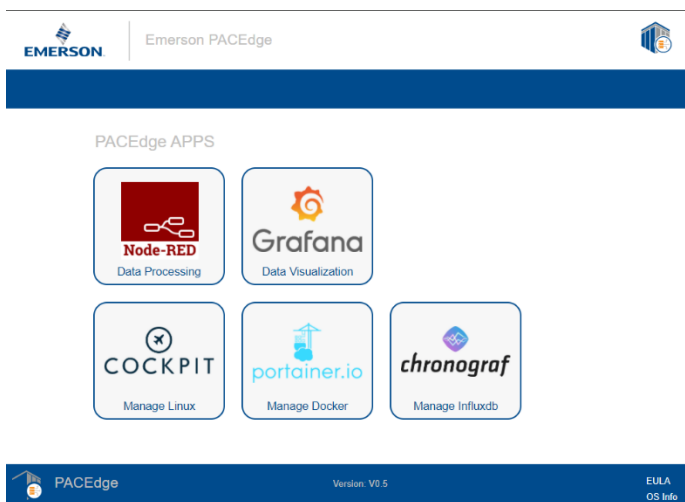

To explore PACEdge, click on Node-RED and log-in with:

- **user:** admin
- **password:** edgestack

Start exploring example flows or create your own flows. Consult the PACEdge User Manual (GFK-3178) for example details.

Important: Please consult the PACEdge Secure Deployment Guide (GFK-3197) for recommended password changes and other Cyber Security relevant settings.

Mounting Information

⚠ WARNING

If the RXi2-BP IPC operates in high ambient temperature up to 70°C (149 ° F), the surface of the enclosure, especially the heat sink, can reach a temperature of 85°C (185 ° F) and above. Be careful and do not touch the RXi2-BP IPC with bare fingers.

⚠ CAUTION

Install the RXi2-BP IPC only in rooms with restricted access.

⚠ CAUTION

Hot surfaces are possible, depending on factors such as CPU load, ambient temperature, and so forth. Be careful and do not touch the RXi2-BP with bare fingers!

DIN Rail Mounting

To mount the IPC to a DIN rail, the user will need to connect DIN Rail Clamp #R2B00ACCRM01 to the rear of the IPC:

1. Place the DIN Rail clamp on the rear face of the RXi2-BP IPC.
2. Using a T9 Torx driver, secure the DIN rail with M3x5-A2 screws, tightening to 0.6 Nm. (Do not overtighten.)

Note: For rugged applications, use a thread-locker to ensure that screws do not loosen.

Figure 5: Attaching the DIN Rail Clamp to the RXi2-BP IPC

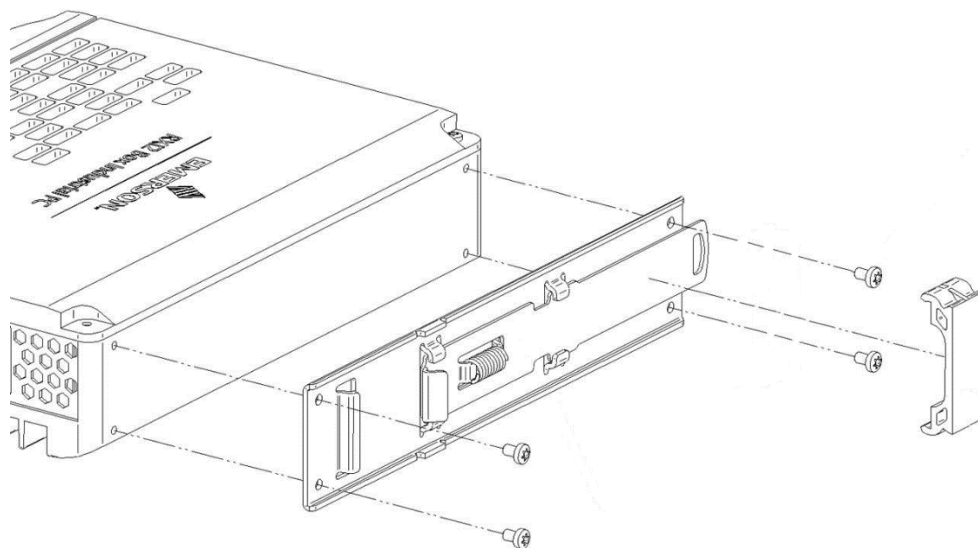

DIN Rail Mounting Options

There are two DIN rail mounting options available, depending on the size of the DIN rail connector.

- If the DIN connector is 7.5 mm in height: use a single DIN rail support to offset the bottom of the IPC.
- If the DIN connector is 15 mm in height: use two DIN rail supports in a stack to increase the height to offset the bottom of the IPC.

Figure 6: DIN Rail Mounting Options

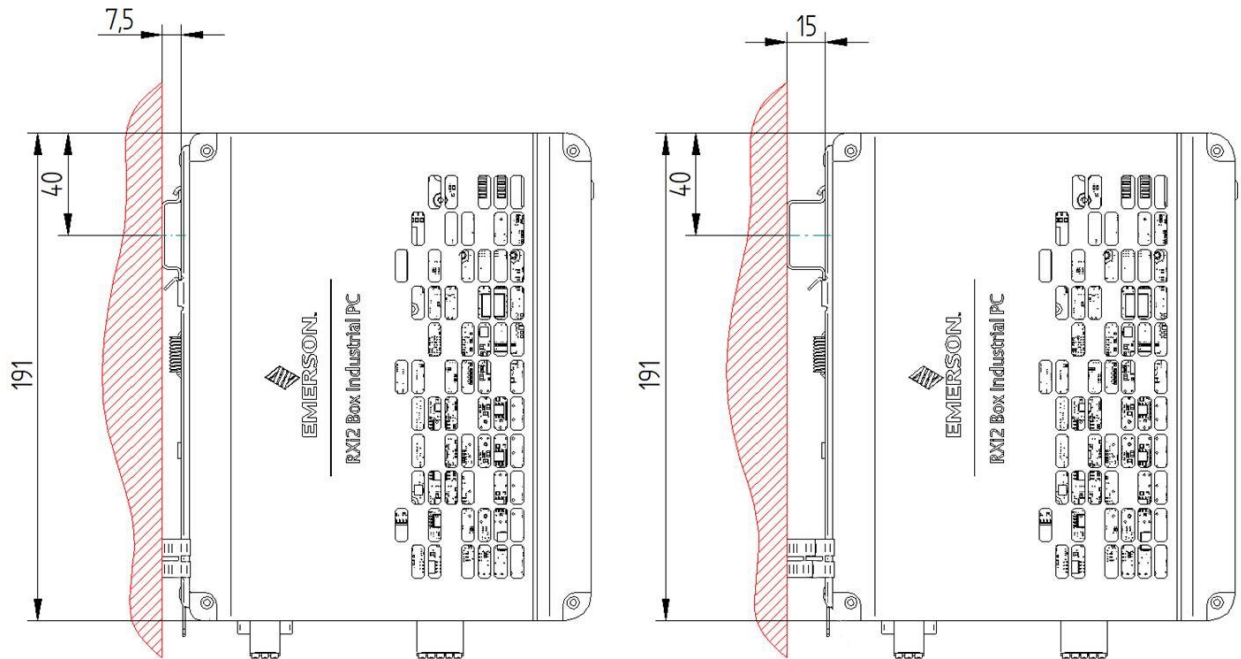

Panel Mounting

To mount the IPC in a panel mount configuration, the user will need to connect Mounting Panel #R2B00ACCOMP01 to the rear of the IPC:

1. Place the mounting plate on the rear of the IPC.
2. Using a T9 Torx driver, secure the mounting plate with two M3x6 screws, tightening to 0.6 Nm. (Do not overtighten.)
3. For regular mounting, secure the mounting plate and IPC through the top and bottom center holes. For more rugged applications, attach four screws in all four corners of the mounting panel.

Figure 7: Panel Mounting Configuration

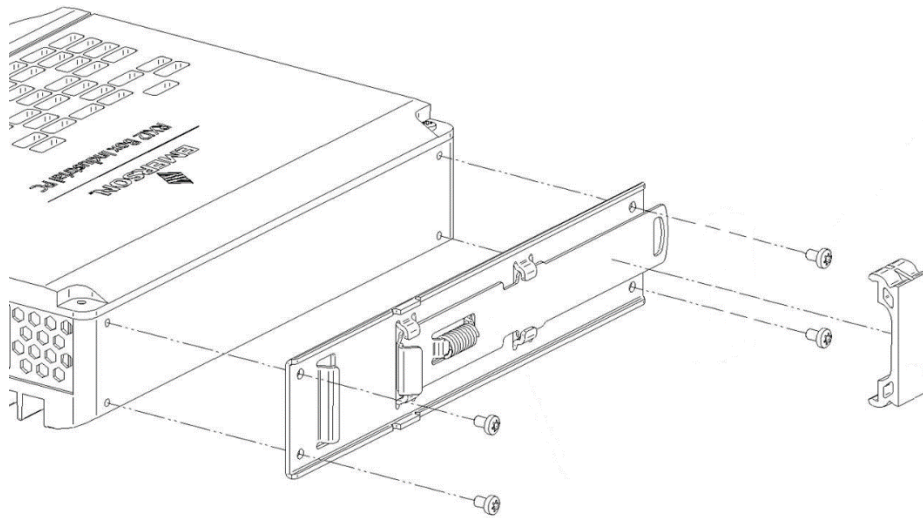
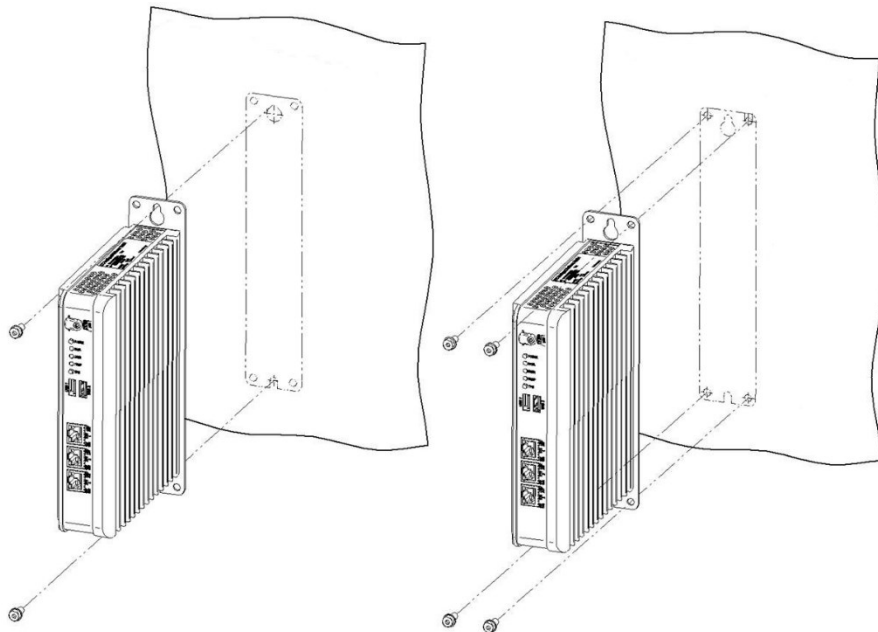

Figure 8: Attaching the Panel Mounts to the RXi2-BP IPC



Clearances Requirements for all Mounting Options

Pictures Figure 9 shows the required clearances required for the RXi-BP to operate within the thermal specifications for both DIN rail and panel mount options.

Any deviation in required clearance will result in a reduced thermal performance and must be evaluated by the customer as a final setup.

Figure 9: Requested Clearances

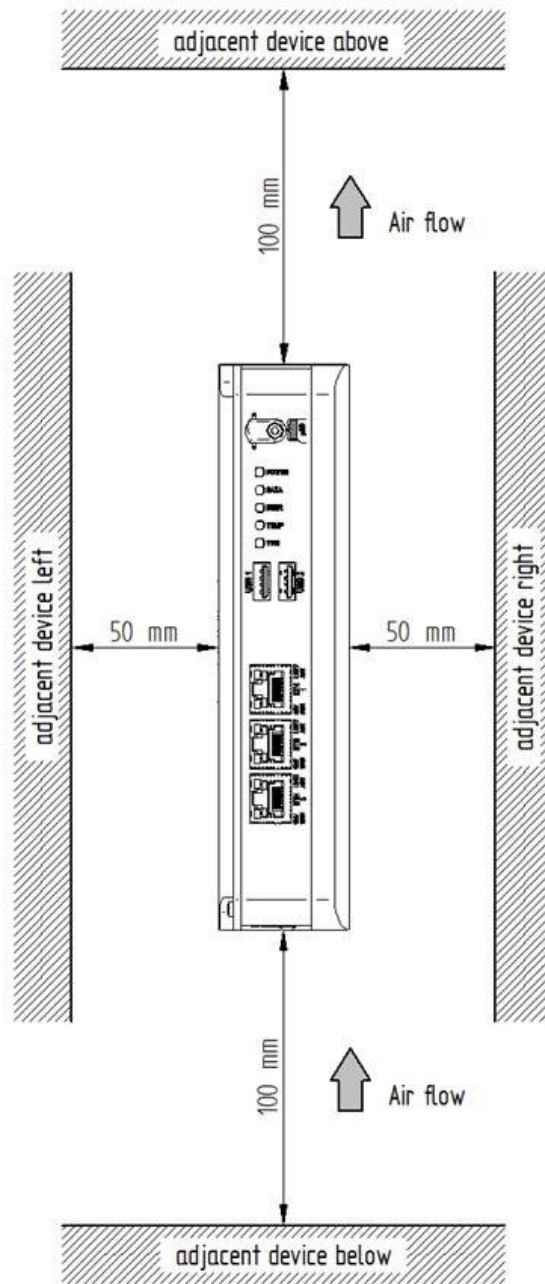

Technical Support & Contact Information

Home link: <http://www.Emerson.com/Industrial-Automation-Controls>

Knowledge Base: <https://www.emerson.com/Industrial-Automation-Controls/support>

Note: If the product is purchased through an Authorized Channel Partner, please contact the seller directly for any support.

Emerson reserves the right to modify or improve the designs or specifications of the products mentioned in this manual at any time without notice. Emerson does not assume responsibility for the selection, use or maintenance of any product. Responsibility for proper selection, use and maintenance of any Emerson product remains solely with the purchaser.

© 2020 Emerson. All rights reserved.

Emerson Terms and Conditions of Sale are available upon request. The Emerson logo is a trademark and service mark of Emerson Electric Co. All other marks are the property of their respective owners.

