

GE provides 3 variants of RSTi-EP safe feed modules EP 1901: one safe input, EP 1902: two safe inputs and EP 1922: two safe inputs, with delayed disconnection, which are intended for connecting safety-related equipment. The RSTi-EP safe feed-input modules are controlled using contact-based safety transducers and/or safety transducers with OSSD (Output Signal Switching Device) inputs. The safety function consists of the safe disconnection of 24 V outputs, the safe state of which is 24 V *switched off* (current path for outputs and the OSSD output is switched off).

All input sensors are independently supplied via separate voltage paths and report the current machine status to the control unit.

Each RSTi-EP safe feed-input module safely switches off all following modules that are supplied by the output current path (until the next EP-7641 power module) and thus creates a safety segment. To switch the 24 V OSSD voltage back on, either an automatic or a manual start can be selected.

- Automatic start: the safe output current path is switched on immediately after resetting the safety circuit(s).
- Manual start: the output current path is only switched on again if the start button has been held down for a preset length of time.

With the delay module (EP-1922), switching off can be delayed by a defined time so that, for example, a machine can be shut down in a controlled manner. The delay time can be set in four steps between 0 and 60 seconds (corresponds to stop category 1 as per EN 60204).

The wiring connectors on each module are color coded for ease of wiring. Refer to the section, *Field Wiring* for additional information.

The RSTi-EP station is usually installed on a horizontally positioned DIN rail. Installation on vertically positioned DIN rails is also possible.

Modules should to be allowed to de-energize for a minimum 10 seconds after power down, prior to starting any maintenance activity.

Refer to the *RSTi-EP Slice I/O Functional Safety Module User Manual* (GFK-2956) for additional information.

Refer to the RSTi-EP Power Supply Reference Guide, a software utility available on PME V9.00, for detailed power-feed requirements.

Module Features

- SIL 3 compliant (IEC 62061 and EN ISO 13849-1, category 4, PL e)
- OSSD outputs
- Emergency-stop circuits
- Wire breakage and short-circuit detection
- Optional delayed shutdown available
- *Spring style* technology for ease of wiring
- DIN rail mounted
- Double-click installation for positive indication of correct installation
- EP-1922 provides optional shutdown time delay in four steps from 0 to 60 seconds
- Supports indirect Firmware update through network adapter using web server.

Ordering Information

Module	Description
EP-1901	1 Safe Feed-Input, 24 VDC
EP-1902	2 Safe Feed-Inputs, 24 VDC
EP-1922	2 Safe Feed-Inputs, 24 VDC, Programmable Delay

Specifications

	EP-1901	EP-1902	EP-1922
System Data			
Data	Process and diagnostic data depend on the network adapter used.		
Interface	RSTi-EP system bus		
System bus transfer rate	48 Mbps		
Safety-related data			
Achievable safety level	SIL3 (IEC 61508), SIL CL3 (IEC 62061), PLe and Cat. 4 (DIN EN ISO 13849-1), regarding the entire safety chain		
DC (Diagnostic Coverage)	96.64%		
MTTFd (Mean Time To Failure dangerous)	> 100 years		
PFH (Probability of Failure per Hour)	6.27×10^{-9} 1/h		
SSF (Safe Failure Fraction)	98.58 %		
HFT (Hardware Fault Tolerance)	1		
Inputs			
Safety inputs	1 x 2channel	2 x 2channel	2 x 2channel
Input type	Type 3 as per IEC 61131-2		
Inputs for start function	2 (manual start and autostart)		
Input type	Type 3 as per IEC 61131-2		
Outputs			
Safety output (OSSD)	1		
Output current	8 A (not for capacitive load)		
Overload protection	Excess temperature proof and overload-proof, short circuit proof with external fuse (see below)		
Turn-off time	< 20 ms		
Turn-on time	< 2 s		
Output SS1	--	--	1
Output current	--	--	0,5 A, overload behaviour as per IEC 61131-2
Overload protection	--	--	Over-temperature, Overload and Short Circuit protection with external fuse (see below)
Auxiliary outputs	2 x 2	3 x 2	3 x 2
Output current	max. 10 A (only to support the inputs dedicated inputs)		
Diagnosis			
Module diagnosis	Yes		
Individual channel diagnosis	Yes		

	EP-1901	EP-1902	EP-1922
Supply			
Supply voltage	20.4V – 28.8V via system bus		
External pre-fusing	mandatory: super fast, max. 8 A		
Reverse battery protection	Yes		
Current consumption (I_{IN} in the power segment of the fieldbus network adapter), typ.	8 mA		
Current consumption (I_{IN} in the respective power segment)	45 mA		
	EP-1901	EP-1902	EP-1922
General data			
Operating temperature	-20°C to +60°C (-4 °F to +140 °F)		
Storage temperature	-40°C to +85°C (-40 °F to +185 °F)		
Air humidity (operation/transport)	5% to 95%, noncondensing as per IEC 61131-2		
Width	11.5 mm (0.45 in)		
Depth	76 mm (2.99 in)		
Height	120 mm (4.72 in)		
Weight	80 g (2.82 oz)	82 g (2.89 oz)	84 g (2.96 oz)

Current Demand for Safe feed-Input Modules

Product	I_{SYS}	I_{IN}	I_{OUT}	I_S	I_L
EP-1901	8 mA	45 mA	--	--	x
EP-1902	8 mA	45 mA	--	--	x
EP-1922	8 mA	45mA	--	-	x
I_{SYS}	Current consumption from the system current path				
I_{IN}	Power consumption from input current path				
I_{OUT}	Power consumption from output current path				
I_S	Current demand of the connected sensors				
I_L	Current demand of the connected actuators				
x	Must be included when calculating the power supply				

LEDs

LED	EP-1901	EP-1902	EP-1922
Module Status	Green: Communication over the system bus		
1.1	Yellow: Safety circuit 1 OK	Yellow: Safety circuit 1 OK	Yellow: Safety circuit 1 OK
1.2	--	--	
1.3	--	--	
1.4	--	--	
2.1	--	Yellow: Safety circuit 2 OK	Yellow: Safety circuit 2 OK
2.2	--	--	--
2.3	--	--	--
2.4	--	--	--
3.1	--	--	--
3.2	--	--	--
3.3	--	--	--
3.4	--	--	--
4.1	--	--	Yellow: SS1 output active
4.2	Yellow: 24 V DC_OSSD active	Yellow: 24 V DC_OSSD active	Yellow: 24 V DC_OSSD active
4.3	Green: Feed-in voltage in valid range	Green: Feed-in voltage in valid range	Green: Feed-in voltage in valid range
4.4	--	--	--

Field Wiring

The connection frame can take up to four connectors, and four wires can be connected to each connector. Those four connectors will be comprised of a Power Connector, one or more *Safety, Start, and Autostart Connector(s)*, and *Blank Connectors* as needed to fill in the connection frame. The *Spring style* technology allows either finely stranded or solid wire conductors with crimped wire-end ferrules or ultrasonically welded wires, each with a maximum cross-section of 1.5 mm² (16 gauge), to be inserted easily through the opening in the clamping terminal without having to use tools. To insert fine stranded wires without wire-end ferrules, the pusher must be pressed in with a screwdriver and released to latch the wire.



**Power
Connector**

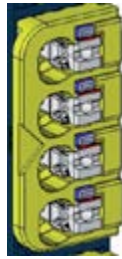

**Safety, Start,
and Autostart
Connector**



**Blank
Connector**

Connector Specifications:

- conductor cross-section 0.14 to 1.5 mm² (26 – 16 gauge)
- max. ampacity: 10 A
- 4-pole

The pushers are color-coded for the following connections:

- White Signal
- Blue GND
- Red 24 V DC

The modules do not have a fused sensor/activator power supply. All cables to the connected sensors/actuators must be fused corresponding to their conductor cross-sections (as per Standard DIN EN 60204-1, section 12).

Refer to the *RSTi-EP Slice I/O Functional Safety Module User Manual* (GFK-2956) for additional information.

For technical assistance, go to <http://support.qe-ip.com>.

Dip Switches

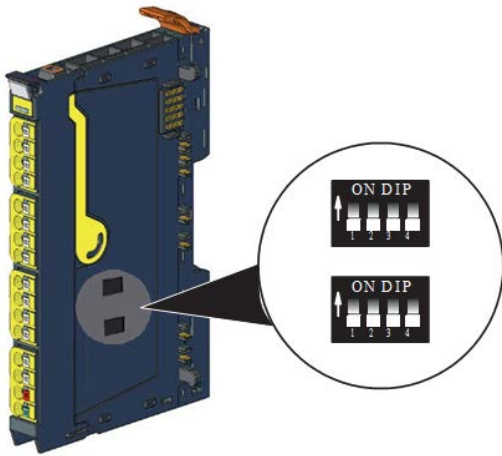

DIP Switch on EP1922 Module

To ensure the safety functions regard the following instructions for adjustment:

- DIP switches of equal numbers must have identical positions in both rows.
- If an external device generating pulses is connected to a safety input of the EP-1922, this input must be operated in mode *no test pulses* (DIP switch setting ON).
- When operating in mode *no test pulses*
 - the test pulses of the external device must be shorter than 2 ms, otherwise the safe output will be deactivated
 - a safe laying of cables can be necessary depending on the required safety level

Note: Use a ball point pen or something similar to set the DIP switches and avoid spiky or sharp-edged tools.

Input		Delay		Function
1	2	3	4	
	x	x	x	Safety input 0 evaluating own test pulses
	x	x	x	Safety input 0 no test pulses
x		x	x	Safety input 1 evaluating own test pulses
x		x	x	Safety input 1 no test pulses
x	x			24 V Safe: no delay
x	x			24 V Safe: delay 1 second
x	x			24 V Safe: delay 30 seconds
x	x			24 V Safe: delay 60 seconds

Setting options for the DIP

= ON

= OFF

X = Setting not relevant

Connection Diagrams

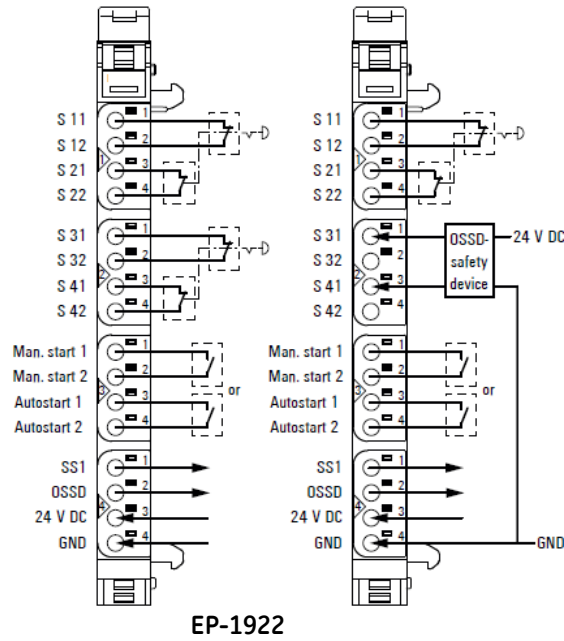
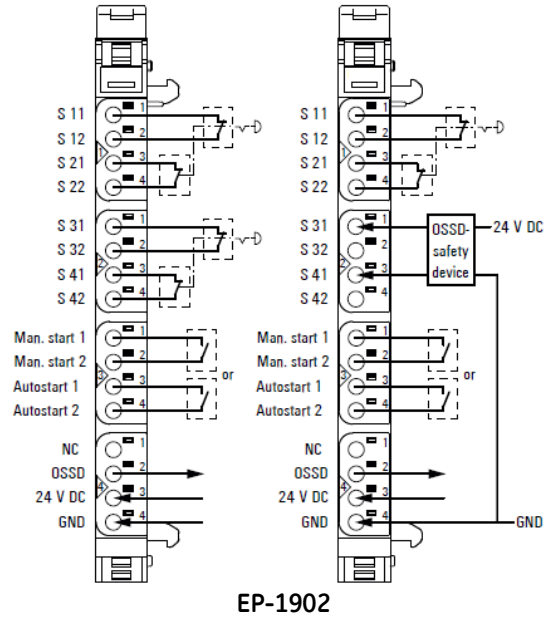
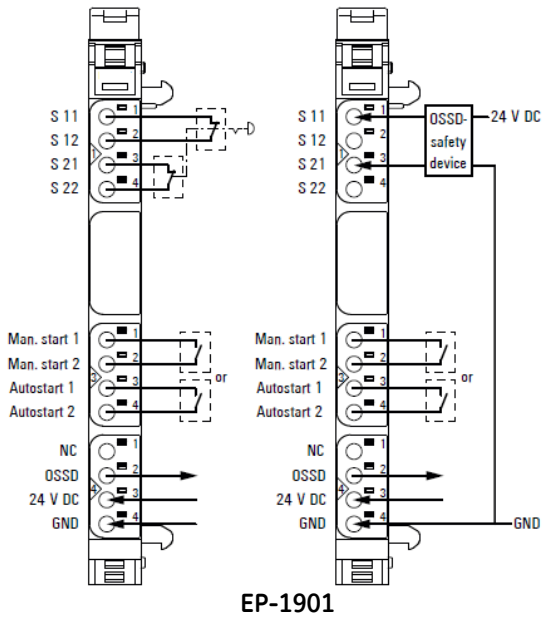

Connection Block Diagrams

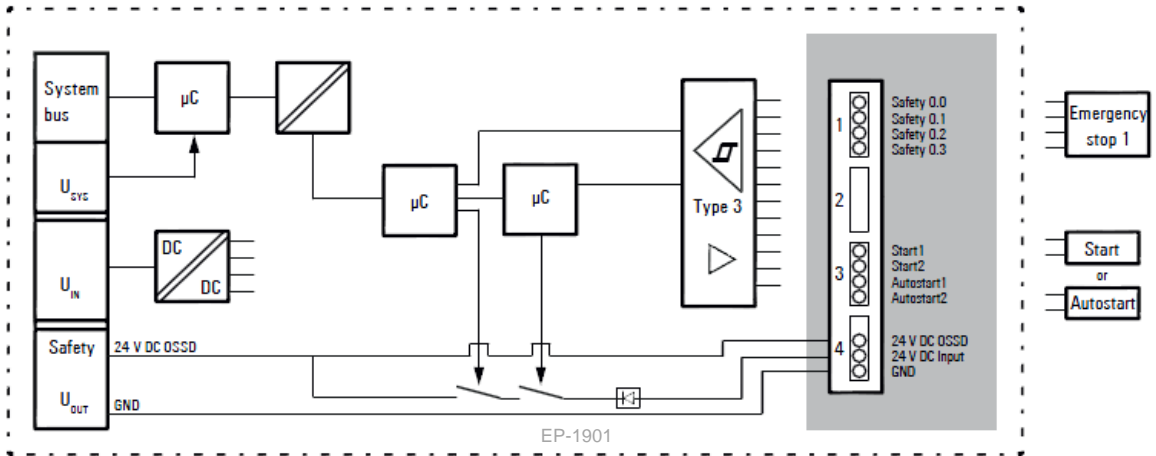

EP-1901

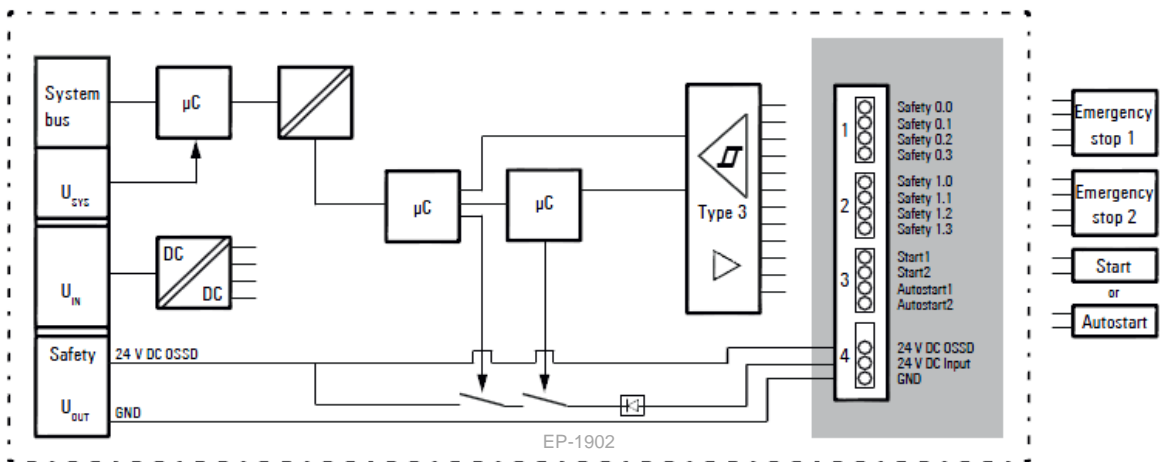

EP-1902

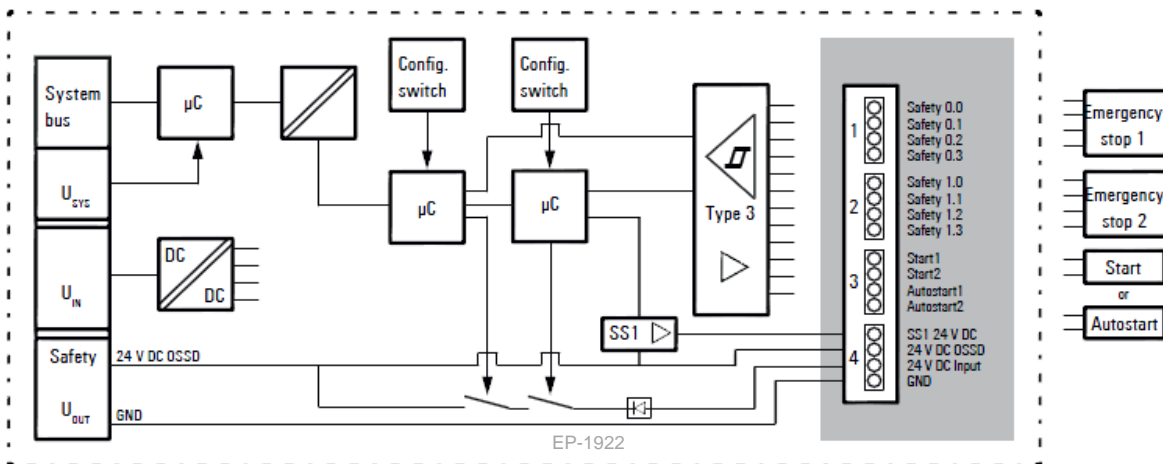

EP-1922

Installation in Hazardous Areas

- EQUIPMENT LABELED WITH REFERENCE TO CLASS I, GROUPS A, B, C & D, DIV. 2 HAZARDOUS AREAS IS SUITABLE FOR USE IN CLASS I, DIVISION 2, GROUPS A, B, C, D OR NON-HAZARDOUS AREAS ONLY



WARNING - EXPLOSION HAZARD - SUBSTITUTION OF COMPONENTS MAY IMPAIR SUITABILITY FOR CLASS I, DIVISION 2;



WARNING - EXPLOSION HAZARD - WHEN IN HAZARDOUS AREAS, TURN OFF POWER BEFORE REPLACING OR WIRING MODULES; AND



WARNING - EXPLOSION HAZARD - DO NOT CONNECT OR DISCONNECT EQUIPMENT UNLESS POWER HAS BEEN SWITCHED OFF OR THE AREA IS KNOWN TO BE NONHAZARDOUS.

ATEX Marking

Ⓔ II 3 G Ex nA IIC T4 Gc

Ta: -20°C to +60°C (-4° F to +140 °F)

Release History

Catalog Number	Firmware Version	Date	Comments
EP-1901, EP-1902, EP-1922	01.13	Dec-2015	Documentation update only
EP-1901, EP-1902, EP-1922	01.13	Nov-2015	Initial Release

Important Product Information for this Release

Updates

None – Documentation update only

Functional Compatibility

N/A

Problems Resolved by this Release

None – Documentation update only

New Features and Enhancements

None – Documentation update only

Known Restrictions and Open Issues

None

Operational Notes

None

Product Documentation

RSTi-EP Slice I/O Module User Manual (GFK-2958)

RSTi-EP Slice I/O Functional Safety Module User Manual (GFK-2956)



1-800-433-2682

1-434-978-5100

www.ge-ip.com

For public disclosure